



US006530897B2

(12) **United States Patent**  
**Nardeo**

(10) **Patent No.:** **US 6,530,897 B2**  
(45) **Date of Patent:** **Mar. 11, 2003**

(54) **STEERABLE MEDICAL CATHETER WITH BENDABLE ENCAPSULATED METAL SPRING TIP FUSED TO POLYMERIC SHAFT**

5,462,527 A \* 10/1995 Stevens-Wright et al. .. 600/585  
5,624,397 A \* 4/1997 Snoke et al. .... 604/525  
5,891,088 A \* 4/1999 Thompson et al. .... 604/524  
6,027,461 A \* 2/2000 Walker et al. .... 600/585

(76) Inventor: **Mahase Nardeo**, 3842 Ashley Ct.,  
Collegeville, PA (US) 19426

\* cited by examiner

(\* ) Notice: Subject to any disclaimer, the term of this patent is extended or adjusted under 35 U.S.C. 154(b) by 0 days.

*Primary Examiner*—Gene Mancene  
*Assistant Examiner*—Patrick Buechner  
(74) *Attorney, Agent, or Firm*—Volpe and Koenig, P.C.

(21) Appl. No.: **09/841,725**

(22) Filed: **Apr. 25, 2001**

(57) **ABSTRACT**

(65) **Prior Publication Data**

US 2001/0037084 A1 Nov. 1, 2001

**Related U.S. Application Data**

(60) Provisional application No. 60/200,442, filed on Apr. 28, 2000.

(51) **Int. Cl.**<sup>7</sup> ..... **A61M 37/00**

(52) **U.S. Cl.** ..... **604/95.04**; 604/528; 600/146

(58) **Field of Search** ..... 604/523, 524,  
604/525, 528, 95.04; 600/146-149, 434;  
70/190, 210, 211, DIG. 7, DIG. 9

A steerable medical catheter is provided having a polymeric main shaft with a plurality of lumen extending therethrough. A flexible shaft tip portion with a metallic coil spring having a polymeric coating is located on the distal end, with the metallic coil spring being fused to the second end of the main shaft. The polymeric coating has an inner portion configured to define a plurality of lumens which extend through the coil spring. The lumens through the coil spring are aligned with the lumens in the main shaft so that they extend continuously through the catheter. The metallic coil spring is fully encapsulated by the polymeric coating and the second end of the main shaft to which it is fused. A first control wire is located in one of the lumens and affixed to the distal end.

(56) **References Cited**

**U.S. PATENT DOCUMENTS**

5,378,234 A \* 1/1995 Hammerslag et al. .... 139/129

**11 Claims, 2 Drawing Sheets**

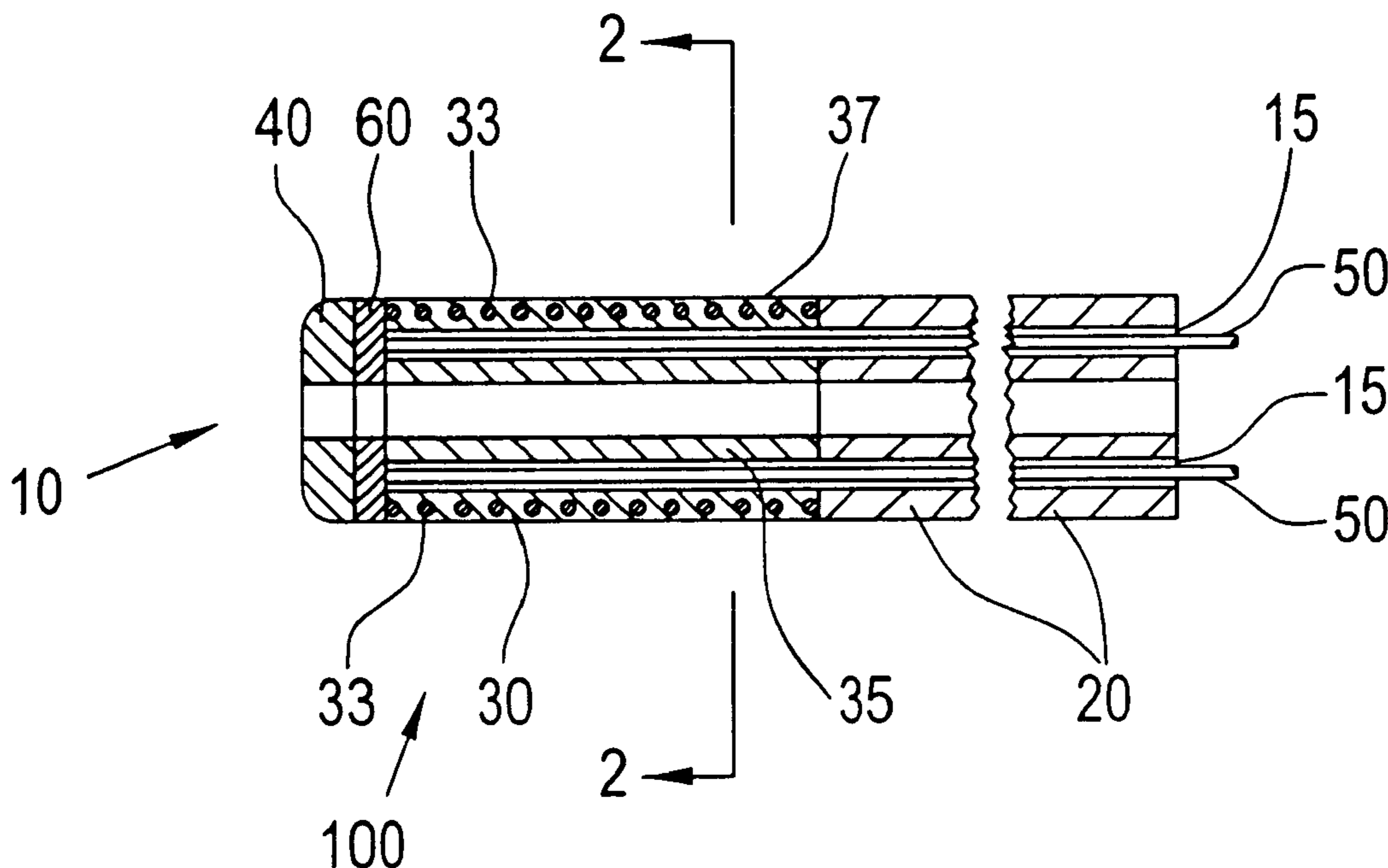

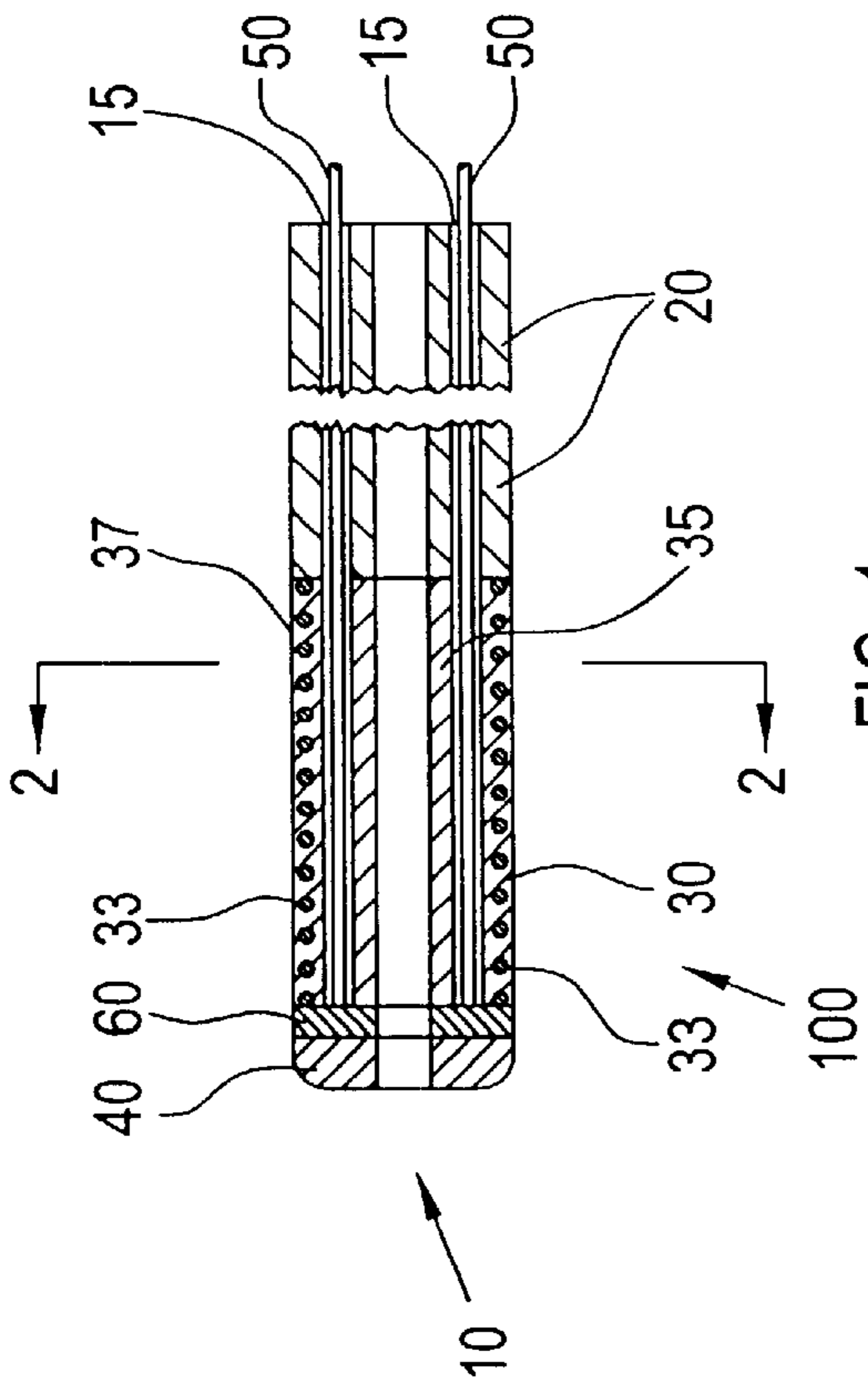

FIG. 1

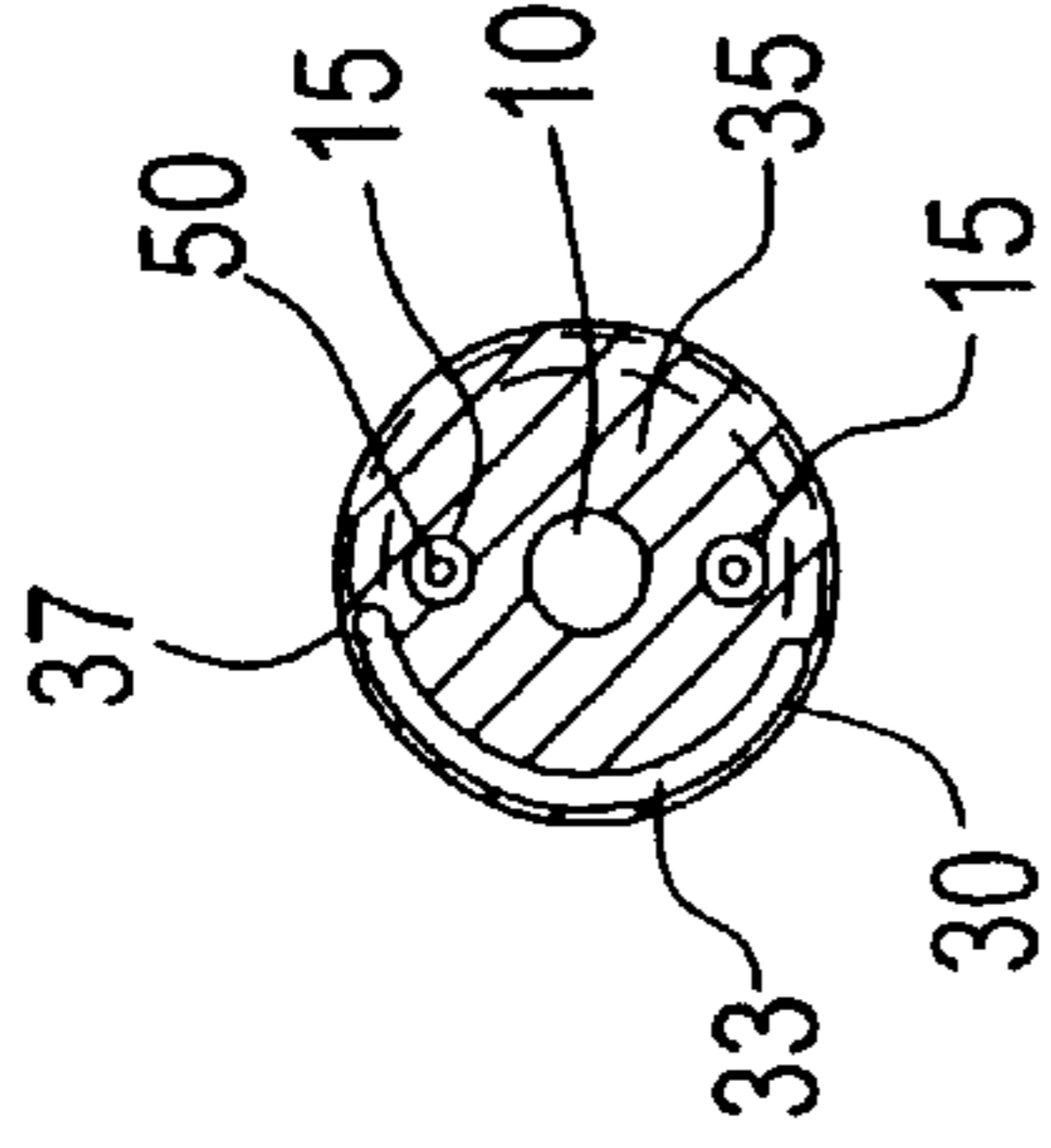

FIG. 2

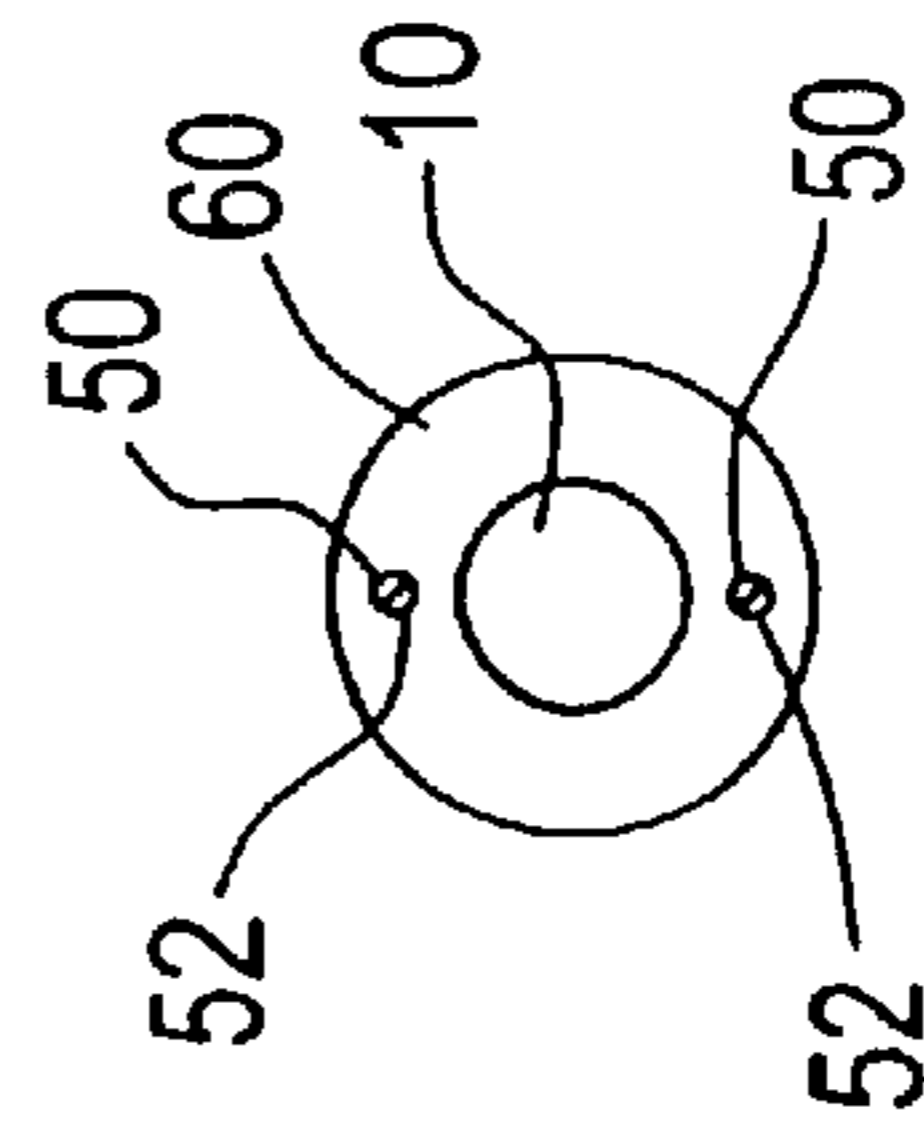

FIG. 3

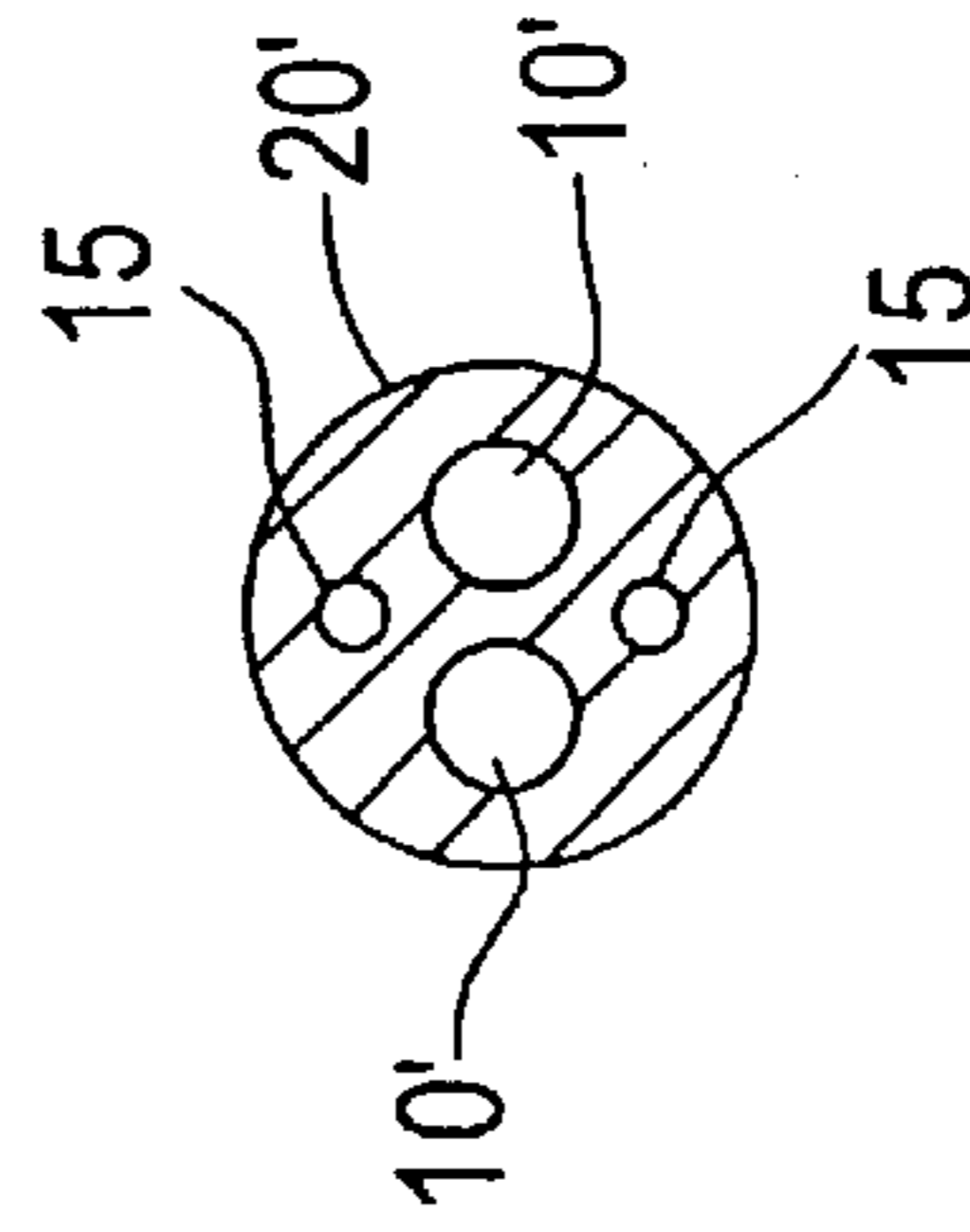

FIG. 4

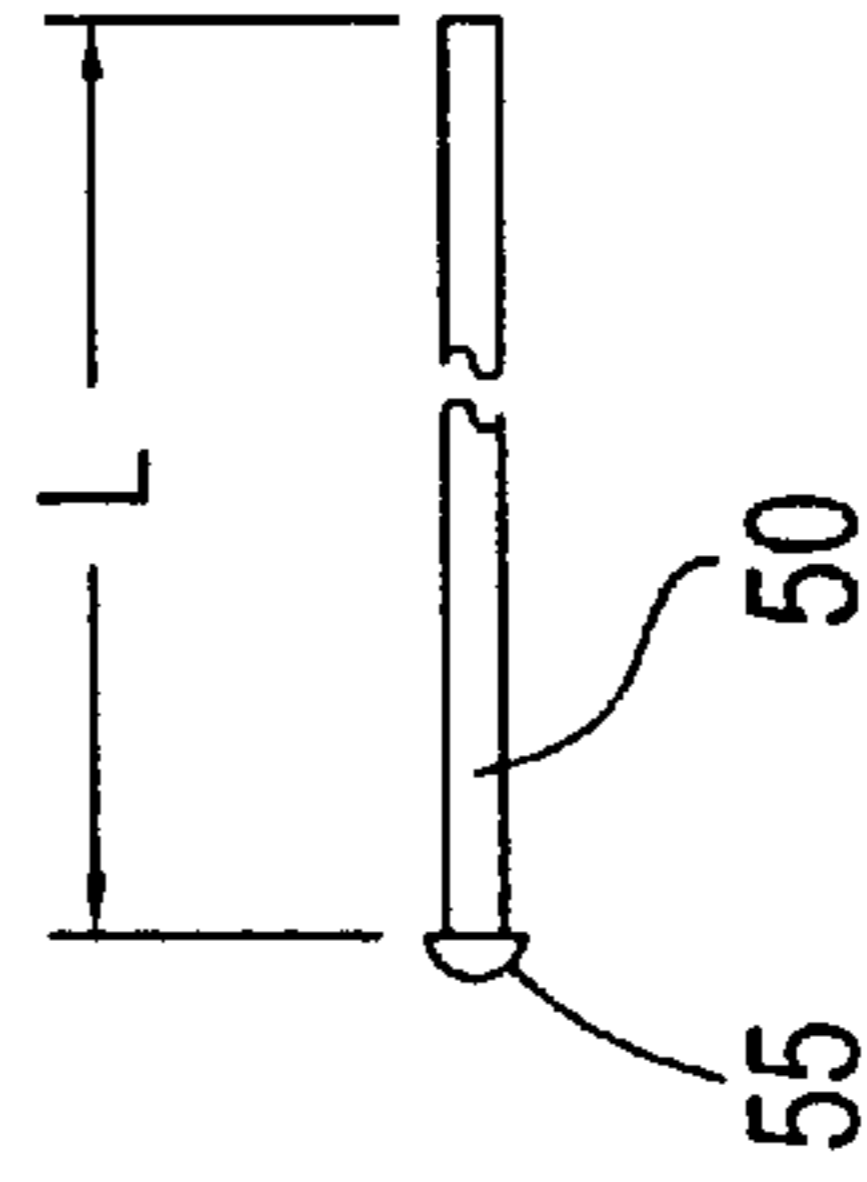

FIG. 5

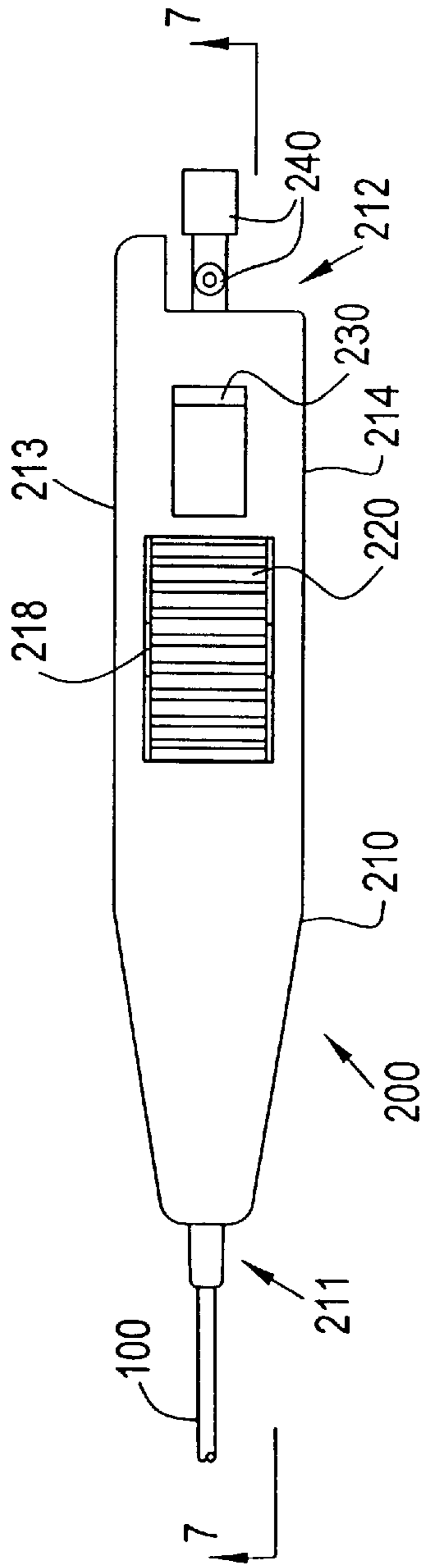

FIG. 6

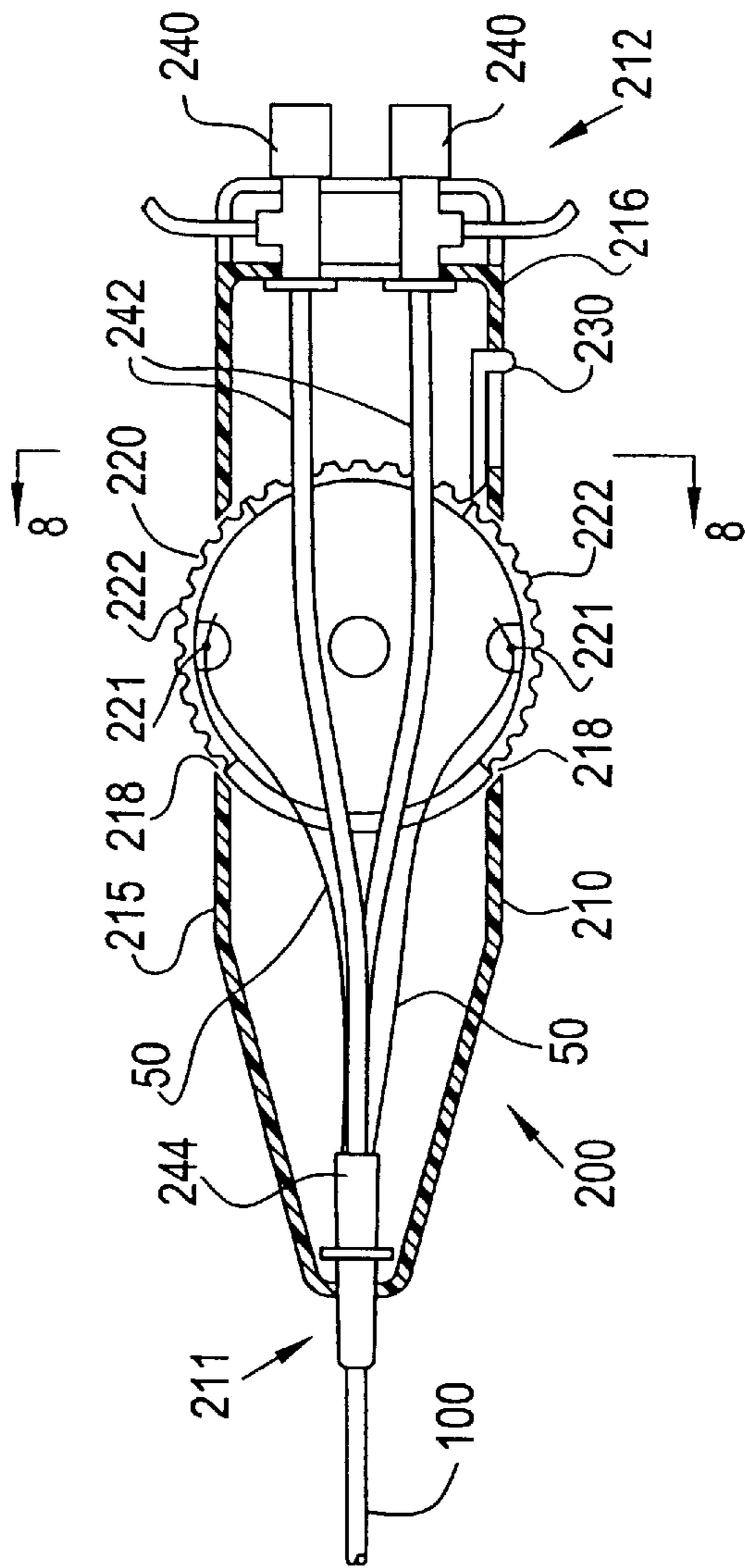

FIG. 7

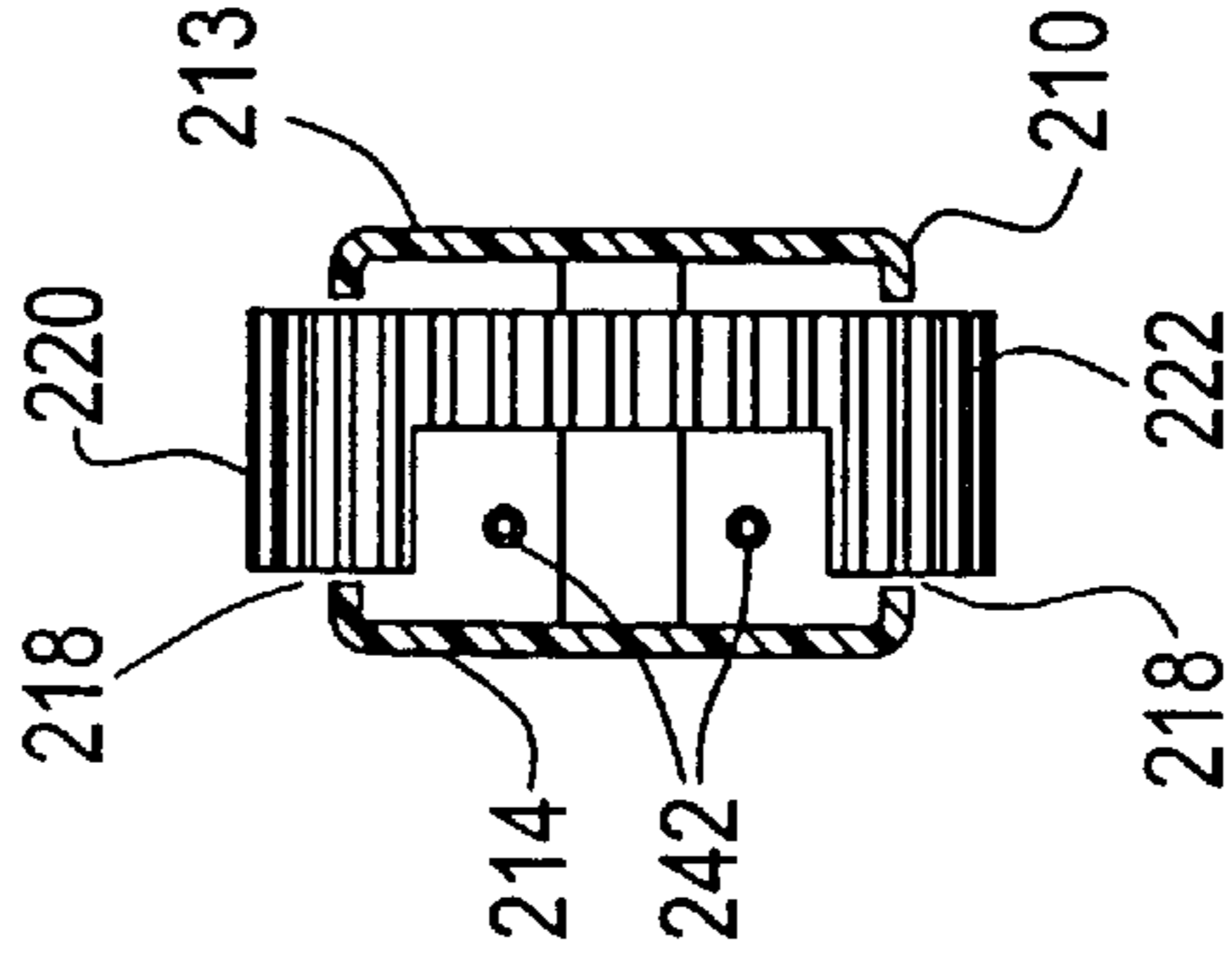

FIG. 8

**STEERABLE MEDICAL CATHETER WITH  
BENDABLE ENCAPSULATED METAL  
SPRING TIP FUSED TO POLYMERIC SHAFT**

**CROSS-REFERENCE TO RELATED  
APPLICATION**

This application claims the benefit of U.S. Provisional Application No. 60/200,442, filed Apr. 28, 2000.

**BACKGROUND**

The present invention relates to the field of steerable medical catheters for insertion into body vessels or cavities which are capable of providing access for surgical and/or medial diagnostic procedures including, but not limited to, providing a conduit for access for fiber optic cables for visualization, lasers, mechanical or electronic devices, surgical devices, or sensors capable of monitoring physiological parameters in situ, such as pressure transducers, flow probes, oxygen sensors, or sensors for other biological or chemical parameters that might be of clinical relevance.

Instruments of this type having a relatively rigid shaft with a flexible, controllable tip are known. In these prior known instruments, the relatively rigid shaft and flexible tip are made of polymeric materials and are bonded together. Control wires extend through lumens in the shaft and are used to deflect the controllable tip in a desired direction for insertion into a body cavity or vessel. The controllable tip is made of a more flexible polymeric material than the shaft, and may include stabilizing strips encapsulated within the more flexible tip portion of the shaft to control deflection of the tip to a desired direction. However, the stabilizing strips in the flexible tip portion are not connected to the relatively rigid shaft, which places additional stress at the butt joint between the tip portion and the relatively rigid shaft.

It would be desirable to provide a more stable connection between a relatively rigid catheter shaft and a flexible tip portion. It would also be desirable to provide a means for holding a flexible tip in a desired orientation during manipulation of such a steerable medical catheter.

**SUMMARY**

Briefly stated, the present invention provides a steerable medical catheter. The catheter includes a polymeric main shaft having first and second ends with a plurality of lumens extending longitudinally therethrough. A shaft tip portion is provided and includes a metallic coil spring with a polymeric coating having first and second ends. The first end of the metallic coil spring is fused to the second end of the main shaft. The polymeric coating has an inner portion configured to define a plurality of lumens between the first and second ends of the coil spring which extend through the coil spring. The lumens through the coil spring are aligned with the lumens in the main shaft to provide continuous lumens through the catheter. The metallic coil spring is fully encapsulated by the polymeric coating and the second end of the main shaft to which it is fused. A first control wire is located in one of the lumens and has a first end which terminates in proximity to the second end of the coil spring and a second end which extends from the first end of the main shaft.

In another aspect, the shaft tip portion may advantageously include a terminal ring fused to the second end of the shaft tip portion. The first end of the first control wire is permanently affixed to the terminal ring, such as by welding, RF welding, adhesives, or other means. Preferably, an end cap is connected to the terminal ring.

In another aspect of the invention, an outer portion of the polymeric coating on the metallic coil spring has an outside diameter that is approximately equal to an outside diameter of the main shaft. The polymeric coating is fused to the second end of the main shaft around the coil spring to form a sealed connection such that the shaft tip portion forms a continuous, smooth extension of the main shaft. The lumens extending through the main shaft and the tip portion remain isolated from one another to provide a continuous path from the first end of the main shaft to the distal end of the catheter for each lumen.

In another aspect of the invention, a control handle is connected to the first end of the main shaft. The first control wire is connected to a rotatable steering dial located in the control handle such that rotation of the steering dial in a first direction causes the tip portion to flex in a corresponding first direction. The metallic coil spring biases the tip portion to return to a position generally axially aligned with the main shaft when the steering dial is released. Advantageously, a locking device may be provided to hold the steering dial in a desired position.

**BRIEF DESCRIPTION OF THE DRAWING(S)**

The foregoing summary, as well as the following detailed description of the preferred embodiments of the invention will be better understood when read in conjunction with the appended drawings. For purposes of illustrating the invention, there are shown in the drawings embodiments which are presently preferred. It should be understood, however, that the invention is not limited to precise arrangements and instrumentalities shown.

In the drawings:

FIG. 1 is an enlarged cross-sectional view of a distal end of a catheter tip in accordance with a first embodiment of the present invention.

FIG. 2 is a cross-sectional view taken along lines 2—2 in FIG. 1.

FIG. 3 is an elevational view, similar to FIG. 2, showing the terminal ring for connecting the control wires.

FIG. 4 is a cross-sectional view of a catheter in accordance with an alternate embodiment of the present invention having two central lumens.

FIG. 5 is a side view of an embodiment of the control wire having a head formed at one end for use in connecting the control wire to the terminal ring.

FIG. 6 is an elevational view of a control handle in accordance with the present invention connected to the catheter in accordance with the present invention.

FIG. 7 is a cross-sectional view taken along lines 7—7 in FIG. 6.

FIG. 8 is an elevational view of the rotatable steering dial taken along lines 8—8 in FIG. 7.

**DETAILED DESCRIPTION OF THE  
PREFERRED EMBODIMENTS**

Certain terminology is used in the following description for convenience only and is not considered limiting. The words “right”, “left”, “lower” and “upper” designate directions in the drawings to which reference is made. This terminology includes the words specifically noted above, derivatives thereof and words of similar import. Additionally, the terms “a” and “one” are defined as including one or more the referenced item unless specifically noted.

Referring to FIG. 1, the present invention provides an elongated medical catheter tubing **100**, a distal end of which is shown in detail, having at least one lumen **10** extending longitudinally therethrough. As shown in FIG. 1, the catheter tubing **100** comprises a main shaft **20**, a flexible tip portion **30**, and an end cap **40**. Preferably, one or more control wires **50** extend through control wire lumen(s) **15** in the main shaft **20** and shaft tip portion **30**, as shown in FIG. 2. The control wires **50** are connected to a terminal ring **60** located at the distal end of the catheter tubing **100**.

In the embodiment shown in FIG. 1, the shaft tip portion **30** comprises a highly flexible metal spring **33**, which is preferably a coil spring, which is located within a polymeric coating having an inner portion **35** and an external portion **37**. The external portion **37** of the coating of the shaft tip portion **30** is finished such that the external surface of the catheter tubing **100** is seamless and continuous throughout the length of the end cap **40**, the shaft tip portion **30** and the main shaft **20**. Similarly, the inner portion **35** of the coating of the flexible tip portion **30** seals the spring **33** from leaks, and is finished to provide a seamless internal surface continuous with the lumens which extend through the main shaft **20**, such that the lumens extend the length of the catheter tubing **100**.

The control wire **50** extends approximately the entire length of the catheter tubing **100** and may be contained within the catheter lumen **10**, or in separate, parallel lumens **15** within the main shaft **20** and the shaft tip portion **30**. As shown in FIG. 3, for the single lumen embodiment of the present invention, the control wires **50** terminate on the terminal ring **60** where the free ends of the control wires **50** may be secured by radio frequency (RF) welding, adhesives or other means of affixing the wires to the terminal ring **60**. The central aperture provided by the terminal ring **60** accommodates the main lumen **10** of the catheter without obstruction. The terminal ring **60**-wire **50** assembly is incorporated between the end cap **40** and the flexible shaft tip portion **30** by RF welding.

The first end of the metallic coil spring **33** is fused directly to the second of the main shaft **20**. The metallic coil spring **33** is therefore preferably fully encapsulated by the polymeric coating **35**, **37** and the second end of the main shaft **20**.

Referring now to FIG. 4, an alternate dual lumen catheter embodiment of the present invention is shown. The main shaft **20'** includes two central lumens **10'** as well as two parallel lumens **15** for the control wires **50**. The flexible shaft tip portion **30** would be configured in a similar manner providing matching lumens defined through the inner portion **35** of the polymeric coating, such that the lumens extend the length of the catheter tubing.

Referring to FIG. 5, an alternate embodiment of the control wires **50** is shown. In the alternate embodiment, the control wires **50** include a mushroom head **55** which may be affixed to the wires **50** by radio frequency welding, adhesives or other affixing methods. The mushroom head is used to secure the first end of the control wire in proximity to the second, distal end of the coil spring **33**.

In one preferred embodiment of the present invention, the main shaft **20** and the end cap **40** are constructed of a flexible polymeric material, such as a rigid polyurethane. One preferred material is a durometer 7033 ABS plastic, preferably PEBAX, which is compounded with 20% barium sulfate and 1% titanium dioxide. However, those skilled in the art will recognize that other suitable materials may be utilized. The metal spring **33** and control wires **50** may be constructed of

any metal, but are preferably made of 304 stainless steel. The polymeric coating of the shaft tip portion **30** is preferably formed a softer durometer polyurethane material than the material of the main shaft **20**. The coating may be applied to the metal spring **33** via a dipping process, with the lumens being formed in the inner portion **35** of the coating via removable mandrels located within the spring **33** during dipping. The first end of the spring **33** is then exposed for connection to the second end of the main shaft **20**. The second end of the spring **33** may be encapsulated by the coating, or by being fused to the terminal ring **60**, which may also be made of a polymeric material.

In the present invention, the metal spring **33** is connected directly to the second end of the main shaft **20** through fusing via a RF welding technique. This provides a polymer-to-metal fusion between the metal spring **33** and the polymeric main shaft **20** unique to the present invention, which was not previously known in the prior art, which generally utilized a polymer-to-polymer construction for connection of the flexible tip portion to the main shaft. The end cap **40** is also connected to the second end of the shaft tip portion **30** by RF welding.

As shown in FIG. 1, the junction of the flexible shaft tip portion **30** to the main shaft **20** is near the distal end of the catheter tubing **100**, and the end cap **40** serves to provide a continuous plastic covering to prevent exposure of the second end of the metal spring **33**, the control wires **50** or the terminal ring **60**.

While the embodiments of the catheter shaft described above are preferred, they are intended to be merely exemplary and a wire variety of shapes, sizes and configurations of the inventive catheter could be utilized. For example, more or less lumens could be provided, and the shape of the catheter could be changed to any polygonal or smooth, non-circular shape as desired. Additionally, single or multiple control wires **50** could be utilized depending upon the desired functionality.

Referring now to FIGS. 6-8, a control handle **200** for one embodiment of the present invention is shown. The control handle **200** comprises a housing **210**, a steering dial **220**, a sliding locking device **230** and one or more catheter ports **240**. The housing **210** has a distal end **211**, from which the catheter **100** extends, and a proximal end **212**, with the one or more catheter ports **240**. In the preferred embodiment, the housing **210** is molded from a polymeric material, and may be constructed of a rigid ABS plastic, such as polystyrene. However, other suitable materials may also be used. The housing **210** includes a right side surface **213**, a left side surface **214**, a top surface **215** and a bottom surface **216**. The housing **210** is ergonomically designed to be held in the hand of an operator. The distal end **211** of the control housing **210** tapers to receive the proximal end of the catheter tubing **100**. The catheter lumens **10** are in communication with the catheter ports **240** via tubes **242** which extend through the housing from an end fitting **244** on the distal end of the catheter **100**, to allow for access or fluid/medicament infusion therethrough.

The control wires **50** extend from the distal end of the catheter tubing **100** into the inner space defined by the housing **210**. The second, distal ends of the control wires **50** terminate on opposing pins **221** located on the rotatable steering dial **220**. Rotational movement of the steering dial **220** selectively pulls one of the attached control wires **50**, resulting a deflection of the flexible tip portion **30** on the distal end of the main shaft **20** in a corresponding direction. Alternatively, the control wires **50** may terminate on a gear

5

or other device mechanically controlled by motion of the steering dial 220. The steering dial 220 turns freely on an axis molded into the inner portion of the housing 210, and preferably includes gear-like teeth 222 peripherally that allow for controlled motion of the steering wheel 220 and the attached control wires 50.

One or more slots 218 are provided on the top or bottom surfaces 215, 216 of the housing 210 that allow the teeth 222 of the steering dial 220 to protrude there through for manual control by an operator. Therefore, selected rotation of the steering dial 220 provides alternating amounts of tension on the guide wires 50, thereby actuating the flexible tip portion 30 of the catheter tube 100 to move in a desired direction. The catheter 100 of the present invention thus allows for very sensitive and accurate steering that is controlled with minimal increments of rotation of the steering dial 220. While the embodiment of the control handle 200 shown in FIGS. 6-8 includes two control wires 50, it will be recognized by those skilled in the art from the present disclosure that a single control wire 50 could be utilized to bend the flexible tip portion 30 in a controlled manner in a single direction.

One or more sliding mechanisms 230 are provided on the external surface of the housing 36. The sliding mechanism 230 may be moved from a first position, out of contact with the steering dial 220, to a second position, in contact with the steering dial 220 to lock the steering dial 220 in a desired position. Preferably, the catheter ports 240 are provided with valves or caps to regulate the flow or access there through.

The above description is intended to be illustrative and not restrictive. Many modifications will be apparent to those skilled in the art based upon a reading of the above description. Accordingly, the scope of the invention should not be determined with reference to the detailed description of the preferred embodiments provided above, but should instead be determined with reference to the appended claims.

What is claimed is:

1. A steerable medical catheter, comprising:

a main shaft made entirely of polymeric material having first and second ends with a plurality of lumens extending longitudinally therethrough;

a shaft tip portion comprising a metallic coil spring with a polymeric coating having first and second ends, the first end of the metallic coil spring is fused to the second end of the main shaft, the polymeric coating having an inner portion configured to define a plurality of lumens between the first and second ends of the coil spring which extend through the coil spring, the lumens through the coil spring being aligned with the lumens in the main shaft such that the lumens extend through the catheter, the metallic coil spring being fully encapsulated by the polymeric coating and the second end of the main shaft; and

a first control wire located in one of the lumens having a first end which is attached in proximity to the second end of the coil spring and a second end which extends from the first end of the main shaft.

2. The steerable medical catheter of claim 1, wherein the shaft tip portion further comprises a terminal ring fused to

6

the second end of the metallic coil spring, the first end of the first control wire being permanently affixed to the terminal ring.

3. The steerable medical catheter of claim 2, wherein the tip portion further comprises an end cap connected to the terminal ring.

4. The steerable medical catheter of claim 1, wherein the polymeric coating is made of a material having a softer durometer than the main shaft.

5. The steerable medical catheter of claim 1, wherein an outer portion of the polymeric coating on the metallic coil spring has an outside diameter that is approximately equal to an outside diameter of the main shaft, and the polymeric coating is fused to the second end of the main shaft around the coil spring to form a sealed connection such that the shaft tip portion forms a continuous, smooth extension of the main shaft, and the lumens are isolated from one another.

6. The steerable medical catheter of claim 1, wherein the metallic coil spring is formed of stainless steel.

7. The steerable medical catheter of claim 1, further comprising a control handle connected to the first end of the main shaft, the first control wire being connected to a rotatable steering dial located in the control handle such that rotation of the steering dial in a first direction causes the tip portion to flex in a corresponding first direction, and the metallic coil spring biases the tip portion to return to a position generally axially aligned with the main shaft when the steering dial is released.

8. The steerable medical catheter of claim 7, further comprising teeth located on the rotatable steering dial, and a locking device located on the control handle movable from a first position, out of contact with the rotatable steering dial, to a second position, in contact with the steering dial to lock the steering dial in a desired position.

9. The steerable medical catheter of claim 1, further comprising a second control wire which extends through a second lumen of the plurality of lumens in the main shaft and tip portion, the second control wire being located radially opposite to the first control wire and having a first end which is attached in proximity to the second end of the metallic coil spring and a second end which extends from the first end of the main shaft.

10. The steerable medical catheter of claim 9, further comprising a control handle connected to the first end of the main shaft, the first and second control wires being connected to a rotatable steering dial located in the control handle such that rotation of the steering dial in a first direction causes the tip portion to flex in a corresponding first direction, and rotation of the steering dial in a second direction causes the tip portion to flex in a corresponding second direction, and the metallic coil spring biases the tip portion to return to a position generally axially aligned with the main shaft when the steering dial is released.

11. The steerable medical catheter of claim 10, further comprising teeth located on the rotatable steering dial, and a locking device located on the control handle movable from a first position, out of contact with the rotatable steering dial, to a second position, in contact with the steering dial to lock the steering dial in a desired position.

\* \* \* \* \*