



US006530709B1

(12) **United States Patent**
Washington

(10) **Patent No.:** **US 6,530,709 B1**
(45) **Date of Patent:** **Mar. 11, 2003**

(54) **NAIL POLISH APPLICATOR**

(76) Inventor: **Pamela D. Washington**, P.O. Box
12972, Charleston, SC (US) 29422

(*) Notice: Subject to any disclaimer, the term of this
patent is extended or adjusted under 35
U.S.C. 154(b) by 0 days.

(21) Appl. No.: **09/727,033**

(22) Filed: **Nov. 30, 2000**

(51) **Int. Cl.**⁷ **A46B 11/04**

(52) **U.S. Cl.** **401/272; 401/270; 401/112;**
401/117; 401/278

(58) **Field of Search** **401/272, 270,**
401/99, 112, 117, 268, 275, 278, 279, 282

(56) **References Cited**

U.S. PATENT DOCUMENTS

2,547,287 A *	4/1951	Sanders et al.	401/99
3,655,290 A	4/1972	Griffith	
3,739,789 A	6/1973	Cataneo et al.	
4,063,829 A	12/1977	La Mura	
4,447,169 A	5/1984	Vartoughian	
4,594,014 A	6/1986	Korper	
4,625,741 A	12/1986	Gardiner	
4,640,637 A	2/1987	Winthrop	
4,726,386 A	2/1988	Schultz	
4,768,529 A	9/1988	Mahrski	
4,838,722 A	6/1989	Katz	
4,927,282 A	5/1990	Morane et al.	
4,946,302 A	8/1990	Uchida	
4,955,745 A	9/1990	Vauquelin	
5,035,525 A	7/1991	Konose	
5,092,702 A *	3/1992	Kurokawa	401/278
5,123,766 A *	6/1992	Babiak	401/278
5,397,195 A *	3/1995	Goncalves	401/277

5,716,104 A 2/1998 Keating et al.
5,735,623 A 4/1998 Gueret
6,174,099 B1 1/2001 Patel et al.

* cited by examiner

Primary Examiner—David J. Walczak
(74) *Attorney, Agent, or Firm*—Kathleen M. Harleston;
Harleston Law Firm LLC

(57) **ABSTRACT**

An elongated, all-in-one applicator for dispensing and
applying liquid nail polish includes:

- (a) an elongated, hollow, generally pen-shaped main
housing having an aperture at one axial extremity;
- (b) an elongated cartridge housing disposed within an
upper portion of the main housing;
- (c) at least one nail polish cartridge comprising a central
chamber for holding a supply of liquid nail polish, the
nail polish cartridge having a first, upper end and an
opposite, second, lower end, the cartridge being dis-
posable within the cartridge housing;
- (d) a brush having a plurality of bristles for applying nail
polish, each bristle having a first end mounted in the
main housing and an opposite, second end which is a
free end;
- (e) a mechanism for dispensing nail polish from the nail
polish cartridge in increments, the nail polish dispens-
ing mechanism having a first position in which nail
polish is contained within the cartridge and is not
dispensed, and a second position in which nail polish is
dispensed from the cartridge through the housing aper-
ture onto the brush; and
- (f) a mechanism for controlling the discharge of nail
polish from the nail polish cartridge onto the brush.

14 Claims, 9 Drawing Sheets

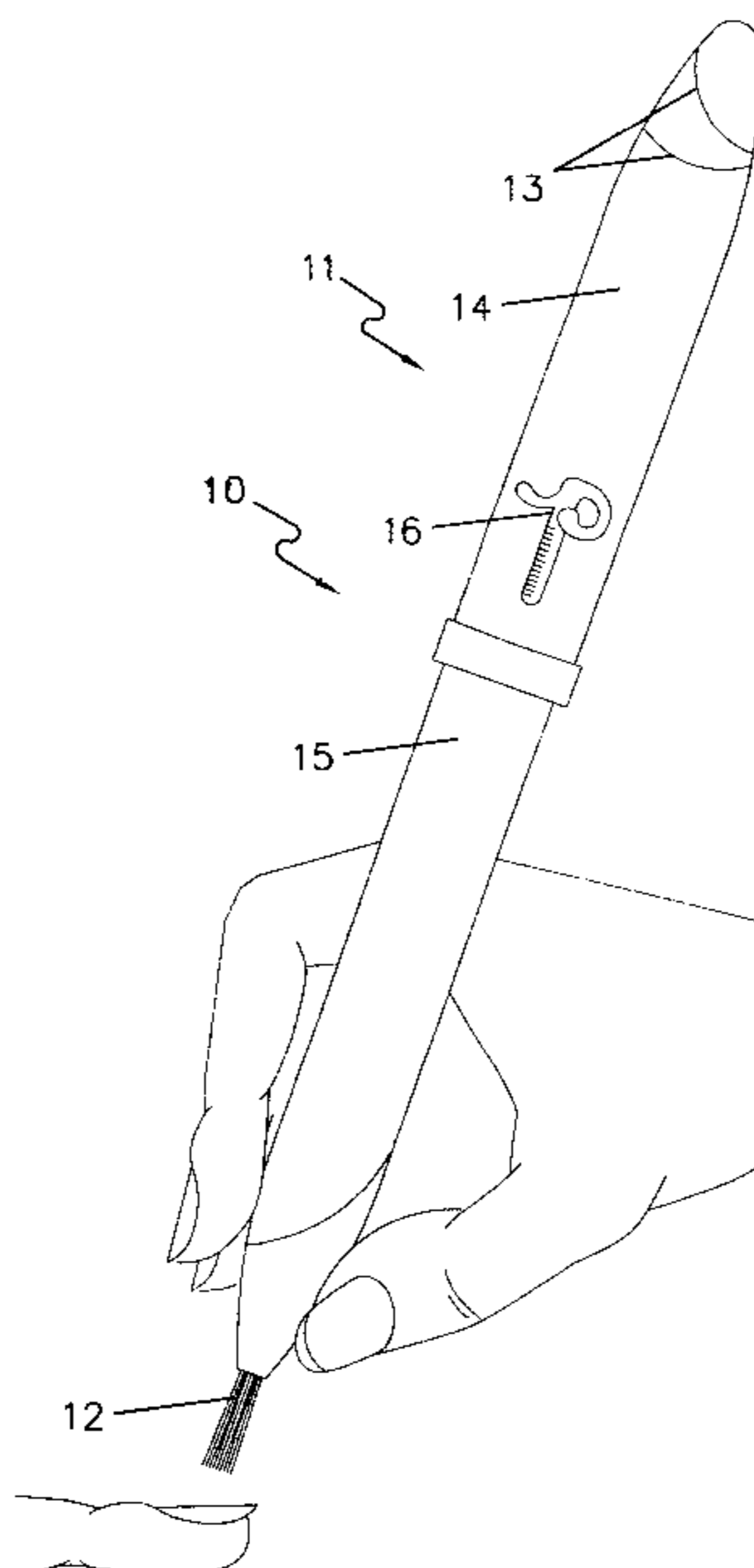

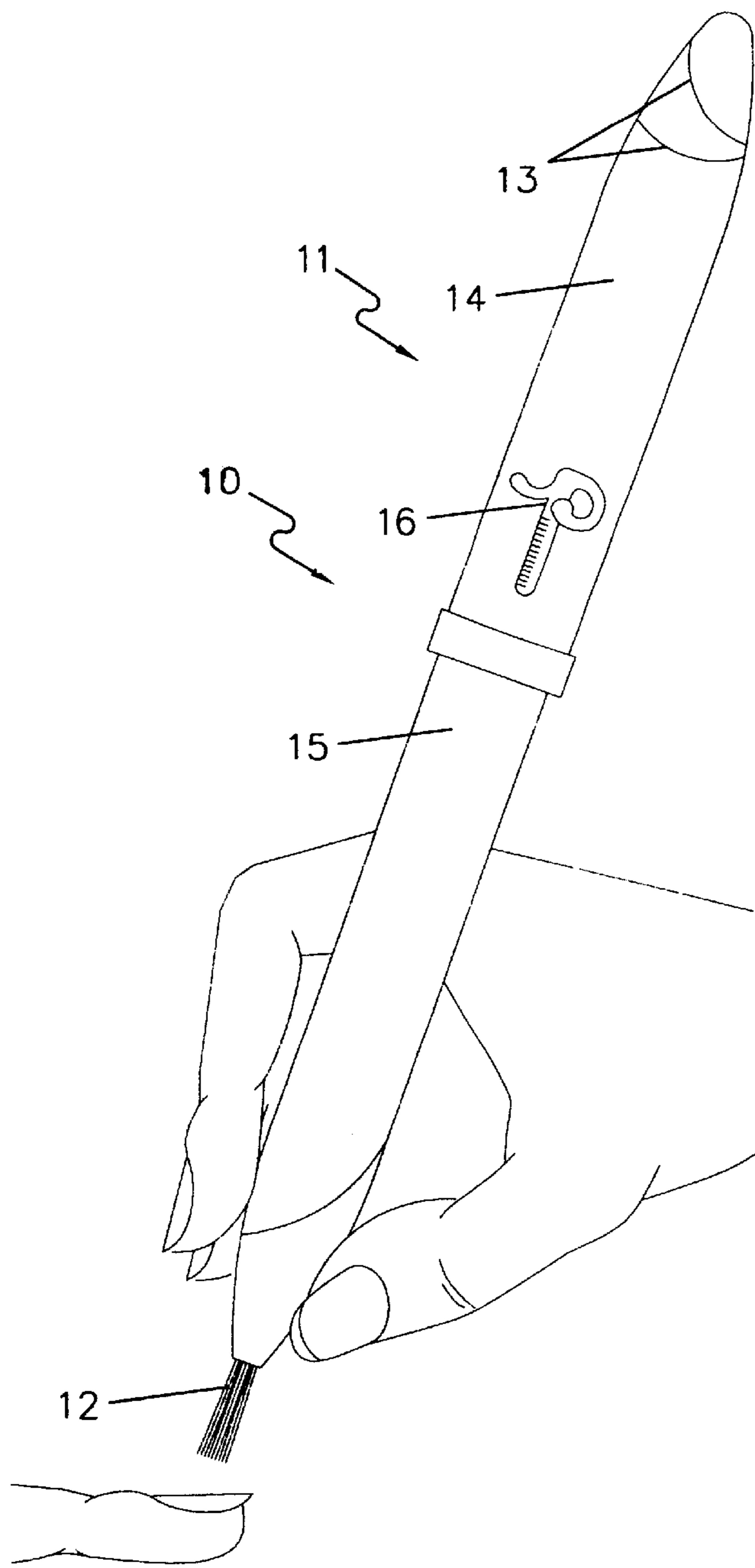

FIG. 1

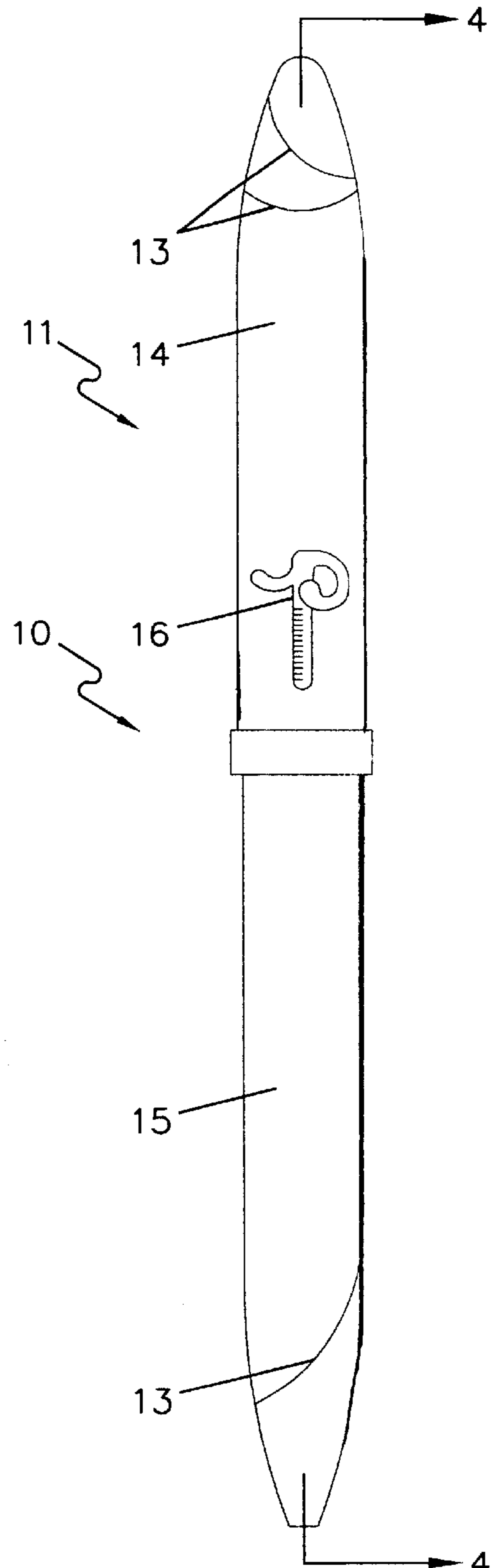

FIG. 2

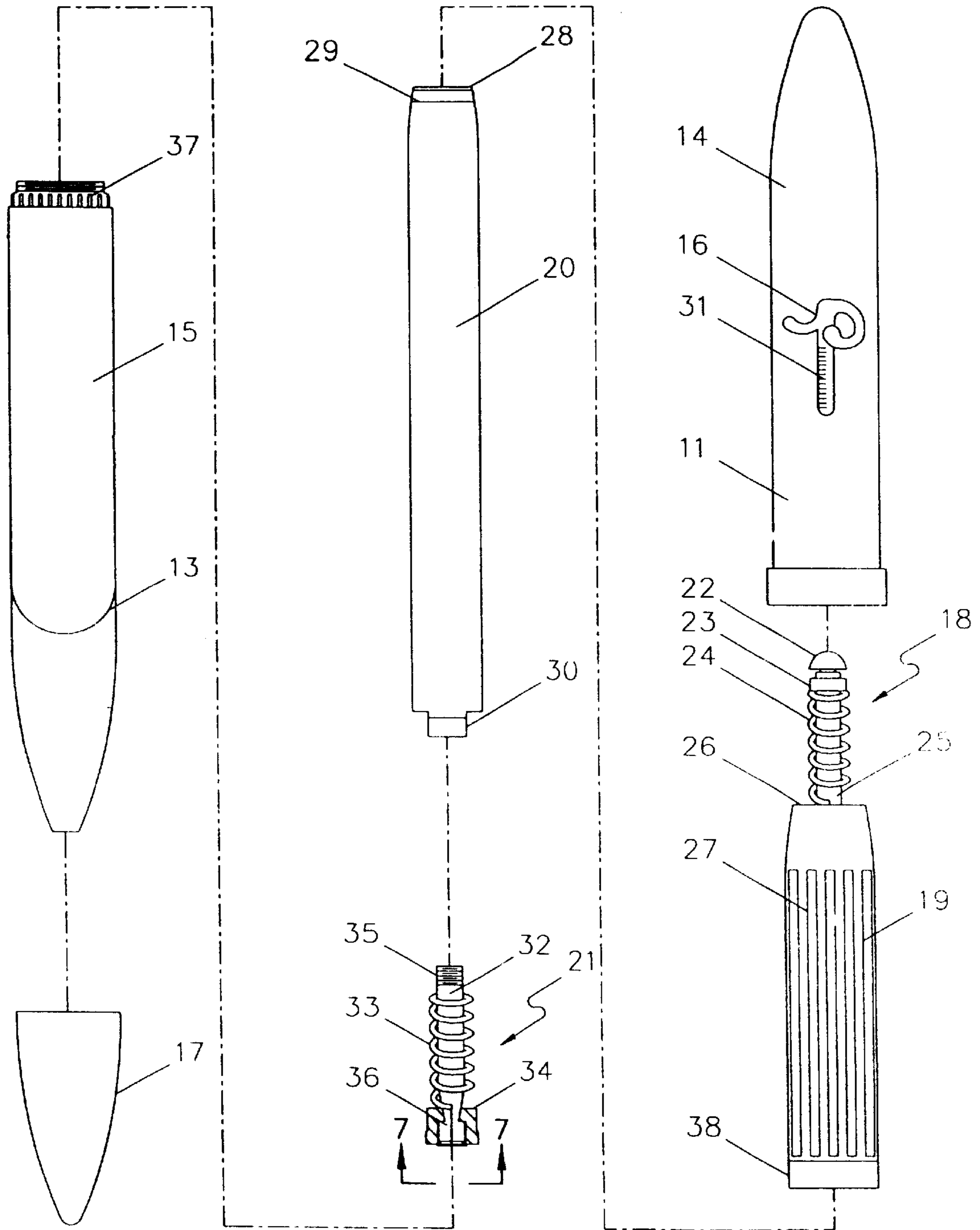

FIG. 3

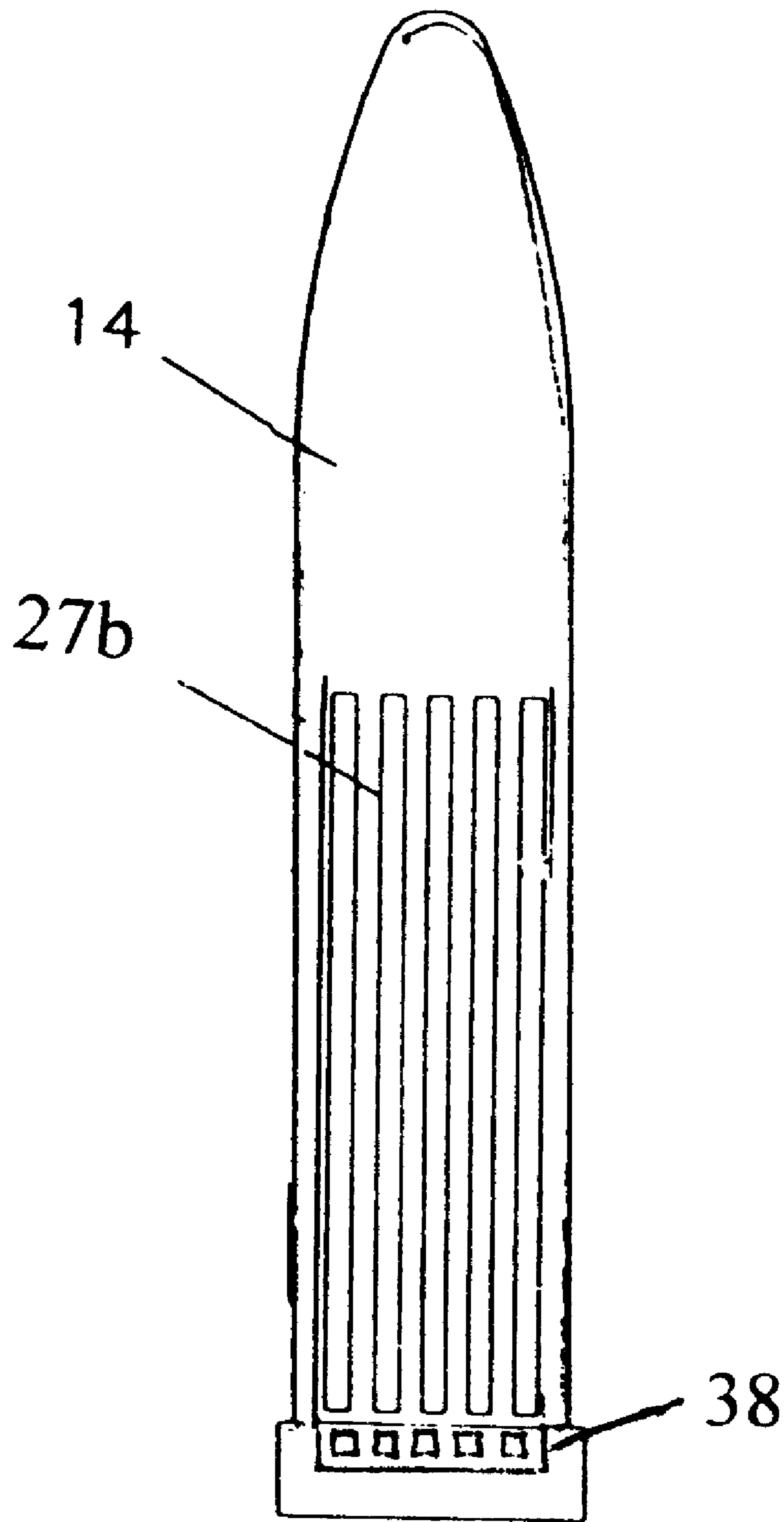
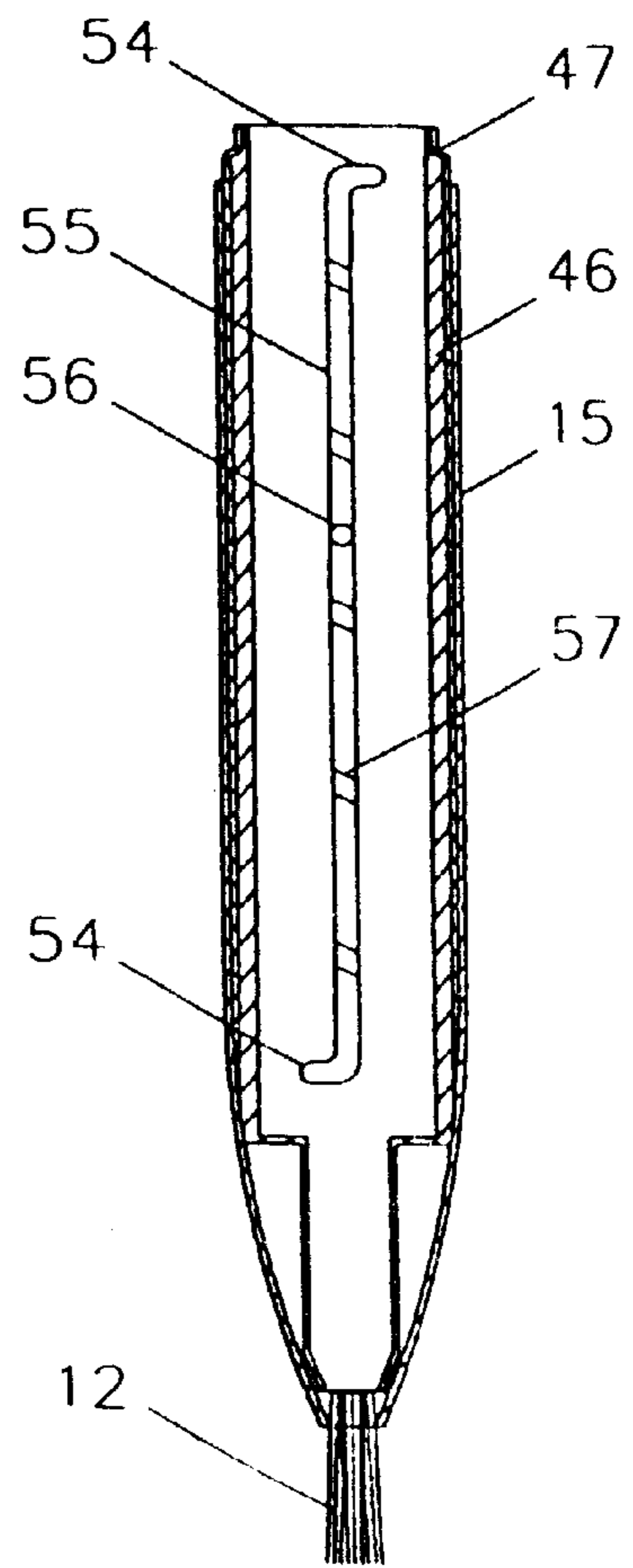
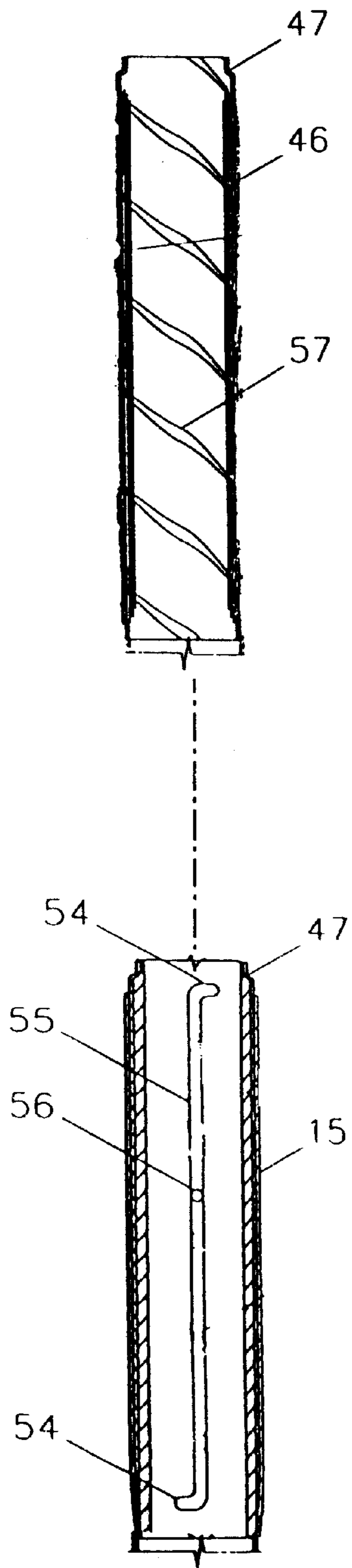

FIG. 3 b



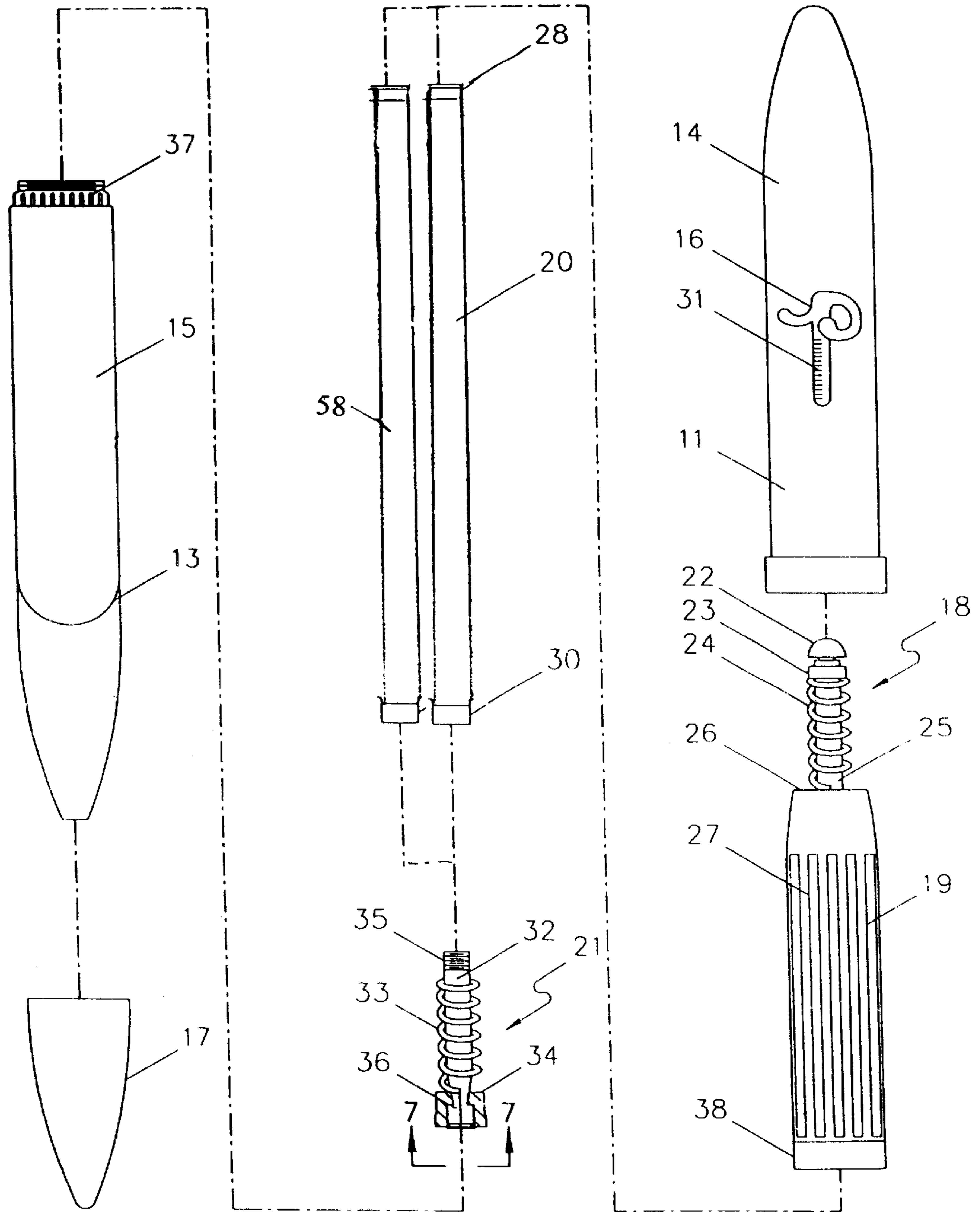

FIG. 14

NAIL POLISH APPLICATOR

BACKGROUND OF THE INVENTION

1. Technical Field

The present device is an all-in-one applicator for dispensing increments of liquid nail polish from a cartridge inside the applicator onto a brush at the bottom of the applicator for quick and easy polishing of fingernails or toenails.

2. Background Information

Generally, nail polish is supplied in small bottles and applied with a brush that is attached to the bottle's screw-on cap. Oftentimes, one or more of the ingredients in nail polish which has not been used for awhile settle out of solution, so the user must invert or shake the bottle prior to use. To apply nail polish, the user removes the cap, dips the brush back into the polish, and wipes one side of the brush along the side of the neck of the nail polish bottle. When additional polish is needed, the user dips the brush back into the bottle of polish, wipes off one side of the brush, and again applies the polish on the brush to their nails. Application of nail polish in this manner requires the use of two hands and repeated trips to the bottle of nail polish. When applying polish to the user's own fingernails, this requires using the hand with recently applied polish, and risking contact with the bottle or nearby objects that may smear the recently applied polish. When this happens, the nail polish on the smeared nail must be removed and reapplied. For professional nail technicians, repeat trips to the bottle of polish and wiping off one side of the brush takes time and increases the cost of doing business and therefore the prices charged to the customer.

Also, small nail polish bottles are easily tipped over and brushes are frequently dropped on the way to or from the bottle. Young girls are fond of painting their nails and frequently end up accidentally spilling hard-to-clean nail polish on furniture, clothing, bedspreads, carpet, etc.

Currently, liquid nail polish is formulated to dry quickly upon application to enable the wearer to resume normal activities as soon as possible. The additional time required for repeated trips to the bottle of polish unfortunately allows the nail polish in the open bottle to dry out. Polish which has been open too long or is old tends to thicken, making future applications more difficult. In addition, nail polish coated along the neck of the bottle, and on the top of brush bristles when they remain above the level of polish in the bottle, tends to harden during storage. This dried polish interferes with future applications of polish and with closure of the bottle when a polishing job is finished. Sometimes it is necessary to dispose of a bottle of nail polish which is only partially empty because the remaining polish is too thick or the bottle is too difficult to reopen.

The present invention allows a user to apply drops of polish on an applicator brush from a reservoir of polish that is not exposed to air. The nail polish applicator of the present invention avoids wasting nail polish, is more efficient, and saves time and money. With the present invention, there is no need for a user to have multiple, partially filled old nail polish bottles lying around. Since there is no stockpile of old bottles to use up, up-to-date polish colors can be purchased without guilt as fashion changes. The applicator of the present invention eliminates the need for repeated trips to the bottle of nail polish and the need to wipe clear one side of the brush on the neck of the bottle.

BRIEF SUMMARY OF THE INVENTION

The present invention is an elongated, all-in-one applicator for dispensing and applying liquid nail polish or the like. This applicator includes:

- (a) an elongated, hollow, generally pen-shaped main housing having an aperture at one axial extremity;
- (b) an elongated cartridge housing disposed within an upper portion of the main housing;
- (c) at least one, most preferably one, nail polish cartridge comprising a central chamber for holding a supply of liquid nail polish, the nail polish cartridge having a first, upper end and an opposite, second, lower end, the cartridge being disposable within the cartridge housing;
- (d) a brush having a plurality of bristles for applying nail polish, each bristle having a first end mounted in the main housing and an opposite, second end which is a free end;
- (e) a mechanism for dispensing nail polish from the nail polish cartridge in increments, the nail polish dispensing mechanism having a first position in which nail polish is contained within the cartridge and is not dispensed, and a second position in which nail polish is dispensed from the cartridge through the housing aperture onto the brush; and
- (f) a mechanism for controlling the discharge of nail polish from the nail polish cartridge onto the brush, the discharge mechanism comprising a button or lever accessible to a user.

BRIEF DESCRIPTION OF THE SEVERAL VIEWS OF THE DRAWINGS

A more complete understanding of the invention and its advantages will be apparent from the following detailed description taken in conjunction with the accompanying drawings, wherein examples of the invention are shown, and wherein:

FIG. 1 is a perspective view of a nail polish applicator according to the present invention;

FIG. 2 is a front elevational view of a nail polish applicator according to the present invention;

FIG. 3 is an exploded view of the nail polish applicator of FIG. 2, shown with an end cap;

FIG. 3b is a longitudinal cross-sectional view of an upper housing of a nail polish applicator according to the present invention;

FIG. 4 is a longitudinal cross-sectional view of the nail polish applicator of FIG. 2, taken across line 3—3;

FIG. 4b is a longitudinal cross-sectional view of a nail polish applicator according to the present invention;

FIG. 4c is a longitudinal cross-sectional view of a nail polish applicator according to the present invention;

FIG. 5 is a cross-sectional view of the nail polish applicator according to FIG. 3, shown in an open position;

FIG. 5b is a longitudinal cross-sectional view of the nail polish applicator according to FIG. 4b, shown in an open position;

FIG. 5c is a longitudinal cross-sectional view of the nail polish applicator according to FIG. 4c, shown in an open position;

FIG. 6 is a cross-sectional view of the nail polish applicator according to FIG. 3, shown in an open, depressed position;

FIG. 6b is a longitudinal cross-sectional view of the nail polish applicator according to FIG. 4b, shown in an open, depressed position;

FIG. 6c is a longitudinal cross-sectional view of the nail polish applicator according to FIG. 4c, shown in an open, depressed position;

FIG. 7 is a latitudinal cross-sectional view of the nail polish applicator taken along line 7—7 of FIG. 3;

FIG. 8 is a latitudinal cross-sectional view of an alternate embodiment of the nail polish applicator of FIG. 3, taken along line 7—7;

FIG. 9 is a front elevational view of an alternate embodiment of a nail polish cartridge according to the present invention;

FIG. 10 is a longitudinal cross-sectional view of an alternate embodiment of a nail polish applicator, showing a locking mechanism;

FIG. 11 is a longitudinal cross-sectional view of an alternate embodiment of a nail polish applicator according to the present invention;

FIG. 12 is a longitudinal cross-sectional view of a portion of a lower housing section of a nail polish applicator according to the present invention; and

FIG. 13 is a longitudinal cross-sectional view of a portion of a lower housing section of a nail polish applicator according to the present invention; and

FIG. 14 is an exploded view of an alternate embodiment of a nail polish applicator according to the present invention, showing a polish remover reservoir.

DETAILED DESCRIPTION OF THE INVENTION

In the following description, like reference characters designate like or corresponding parts throughout the several views. Also, in the following description, it is to be understood that such terms as “upper,” “lower,” “front,” “within,” and the like are words of convenience and are not to be construed as limiting terms. Referring in more detail to the drawings, the invention will now be described.

Turning first to FIGS. 1 and 2, an elongated applicator, designated generally as 10, comprises a main housing 11 and a brush 12. FIG. 1 shows a preferred embodiment of this all-in-one nail applicator 10, which is generally in the form of a fountain pen, being used to apply nail polish to the surface of a fingernail. A user can hold the applicator in one hand while applying polish to the fingernails of the other hand, or it can be held by one person, such as a manicurist, who is applying polish to the fingernails of a second person. The applicator is preferably for use in applying nail polish, although it can be used to apply other fluids of generally similar viscosity, such as gels, acrylics, paint, or glue.

The main housing 11 can be decorated with design swirls or other embellishments 13 embossed on, or depressed into, the housing. In FIG. 2, the swirls at the upper and lower ends of the main housing are examples of such embellishments 13.

The main housing 11 is comprised of an elongated upper housing section 14 having an opening at one axial extremity, and a lower housing section 15 having an opening at one axial extremity, the upper and lower housing sections 14, 15 being detachably joined together at the openings, as shown in FIGS. 1 and 2. Preferably, the upper housing section has small, vertically oriented ribs on the inside that fit between the ribs on the outside of the cartridge housing. The ribs support each other when the housings are turned. The upper housing section 14 in the preferred embodiment shown in FIGS. 1 and 2 comprises a designer logos or emblem, here a stylized letter “P” 16.

The applicator of the present invention is a compact, neat, and convenient way to deliver nail polish. It avoids the need to repeatedly dip a nail polish brush into a nail polish

container, move the brush over to the nail to be painted, move the brush back to the supply, insert it in the nail polish container and seal it. In the present invention, the brush and polish bottle are in one unit, hence, it is an “all-in-one” applicator. It can be used by nail professionals or lay users, and by the young or old.

Referring to the exploded view of FIG. 3, the applicator 10 comprises, from top to bottom, the upper housing section 14, a punch mechanism 18, a cartridge housing 19, a nail polish cartridge 20, a dispenser mechanism 21, the lower housing section 15, and a removable end cap 17. The end cap 17 is recommended. It fits closely over the bottom portion of the lower housing section 15 once the nail polish brush 12 has been retracted into the lower housing section. The end cap 17 may be indented, or have snaps, so that it forms an air tight seal on the lower housing section 15, yet is easily removed. The function of the end cap 17 is to prevent the nail polish brush 12 from drying out, and to keep any nail polish remaining on the brush or the end of the lower housing section from rubbing off onto another surface, such as the user’s hands or the inside of a purse.

Continuing with FIG. 3, the upper housing section 14 covers: the punch mechanism 18, the cartridge housing 19, and an upper portion of the nail polish cartridge 20. The lower housing section 15 covers a lower portion of the cartridge 20, and the nail polish dispensing mechanism 21. The punch mechanism 18, which allows the user to control the discharge of nail polish from the cartridge 20 to the brush 12, comprises: a punch button 22, a punch cap 23, a punch spring 24, and a punch rod 25. The punch spring 24 is movably wrapped around the punch rod 25. An upper end of the punch rod 25 rests against the punch cap 23, and an opposite lower end of the punch rod extends down through an aperture in the upper end 26 of the hollow cartridge housing.

As shown in FIG. 3, the hollow, cylindrical cartridge housing 19 has vertically oriented, spaced apart, narrow ribs 27 on its exterior. These ribs 27 correspond with similar narrow vertical ribs along the inside of the upper housing section 14. The ribs on the outside of the cartridge housing fit between the ribs on the inside of the upper housing section, and vice versa. The ribs help to support the cartridge housing 19 when the upper housing section 14 is turned. The entire cartridge housing fits closely into the upper housing section 14. The interior of the cartridge housing preferably also comprises vertically oriented, spaced apart, narrow ribs which correspond to similar ribs on the exterior of the nail polish cartridge 20. These ribs serve to guide the cartridge into the cartridge housing. An alternative embodiment has no ribs on the cartridge housing or the upper housing section.

As is also shown in FIG. 3, the nail polish cartridge 20 fits closely into the cartridge housing 19. Although it may be fixed, it is preferably removable and replaceable. When the applicator 10 is in a closed position, with the nail polish brush inside, the upper end 28 of the nail polish cartridge 20 rests against the cartridge housing upper end 26. The bottom of the nail polish cartridge projects from the bottom of the cartridge housing 19 and adjoins the top of the dispenser mechanism 21. The nail polish cartridge most preferably includes small, narrow ribs extending vertically down approximately ½ to one inch from the top of the cartridge. Each rib fits between corresponding ribs on the interior of the cartridge housing. The ribs ensure that the nail polish cartridge fits properly into the cartridge housing. The lower end of the nail polish cartridge 20 comprises a collar 30 at the lower end of the cartridge 20.

A fill line **29** showing the nail polish level in the cartridge is shown in FIG. 3. When the nail polish cartridge is empty, or if a user wishes to change polish colors, the user can replace a used polish cartridge with a new one by pulling off the upper housing section **14**, removing the used cartridge **20** from the cartridge housing **19** and replacing it with a new one. Used cartridges are disposable. Refill cartridges are available and a different color nail polish may be selected when the cartridge is replaced. Generally, nail polish cartridges herein contain 0.5 ounces, or 15 milliliters, of nail polish. The cartridge can hold various types of nail polish, including base coats and nail strengtheners, clear protective top coats, scented or unscented nail polish, and various polish colors, with or without glitter. A manicurist can, for example, keep separate cartridges in stock for repeat customers who request the same polish color each trip to the manicurist.

Referring to FIG. 3, the nail polish cartridge **20** and the cartridge housing **19** are preferably made of a sturdy, see-through plastic so that the color of the polish inside the cartridge is visible. Optionally, the color of the nail polish and the amount remaining in the cartridge can be ascertained by a user from the outside of the applicator by viewing the letter "P" **16** on the upper housing section **14**. The vertical bar of the stylized "P" **16** is optionally a clear viewing window, preferably with gauge marks **31** along the side. The nail polish inside can be seen through the window of the stylized "P" **16**, and the level **29** of the polish can be ascertained by comparing the level of the polish showing through the window against the gauge marks **31**. Various letters of the alphabet, designs, or logos can be used instead of a "P". Alternatively, a user may remove the upper housing section to determine the amount (or color) of nail polish remaining in the cartridge. It is recommended that a true color sample be displayed on the product packaging.

As illustrated in FIG. 3, the dispenser mechanism **21** comprises: a dispenser shaft **32**, a dispenser spring **33**, and a movable dispenser sheath **34**. The dispenser spring **33** wraps around the dispenser shaft **32**. The upper end **35** of the hollow dispenser shaft **31** is threadably engaged, preferably by screwing or snapping, to the collar **30** at the lower end of the cartridge **20**. The lower end of the dispenser shaft **32** is divided, which forms a set of jaws **36**. When the applicator is in a first, closed position, the movable sheath **34** extends from the lower end of the spring **33** down to the end of the jaws **36**. Alternatively, when the applicator **10** is in a closed position, the movable sheath **34** extends around the dispenser spring **33** and the dispenser shaft **32** from the threaded upper end of the dispenser shaft to the lower end of the jaws **36**. The jaws **36** cannot open when the dispenser sheath **34** is in place around them. Conversely, the jaws do open when the dispenser sheath is not in place over the jaw.

The lower portion of the nail polish cartridge **20** and the dispenser mechanism **21** fit into a lower housing section **15**, as shown in FIG. 3. The number of disposable elements within the whole applicator may vary. First, if the dispenser shaft **32**, or the rest of the dispenser mechanism **21**, clogs or breaks, it can be pulled out of the lower housing section **15**, unscrewed from the nail polish cartridge **20**, and inexpensively replaced. A second alternative to the disposable dispenser mechanism is an applicator with a dispenser mechanism **21** that is affixed to the nail polish cartridge **20** and the whole dispenser/cartridge unit is disposable. A third, preferred alternative to the disposable dispenser mechanism is a permanently affixed dispenser mechanism **21** that is not removable or disposable, although the cartridge **20** can be removed by unscrewing it from the dispenser mechanism. In

a fourth alternative, rather than) individual disposable elements, the entire applicator is disposable.

As shown in FIG. 3, the upper end of the lower housing section **15** is recessed and holds a rotatable band **37** having a series of short, vertically oriented grooves on the outside of the band. A band **38** on the lower end of the cartridge housing fits into grooves on the upper rotatable band **37**. The cartridge housing **19**, then, fits tightly over the band **37** on the upper end of the lower housing section **15**. The cartridge housing **19** fits closely into the upper housing section **14**. By grasping the upper housing section **14** with one hand and the lower housing section **15** with the other hand and twisting, a user can rotate the upper housing section clockwise or counterclockwise about these bands **37**, **38**, which are along the midline of the applicator. This action raises the nail polish brush **12** into the lower housing section **15**, or lowers it for use. The band **37** is directly or indirectly connected to the drum housing **47** within the main housing **11**, and is rotatable with the upper housing section **14**. When the upper drum housing section **14** is rotated, the brush **12** is enabled to move between its first and second positions.

FIGS. 4 through 6 show cross-sections of an applicator **10** along its longitudinal axis at the centerline of the applicator. FIG. 4 shows the applicator **10** when it is not in use. In FIG. 5, the twist mechanism has been employed to lower the brush **12** from the aperture housing **44**. As a result, the nail polish cartridge **20** is lower. In FIG. 6, the punch mechanism **18** has been punched, which causes nail polish to appear on the brush. The punch mechanism **18** at the top of the applicator **10** is used to dispense nail polish onto the nail polish brush **12** once it has been lowered by twisting the applicator at the midsection.

Specifically, when a user pushes down on the upper housing section **14**, or the top of the applicator, the punch button **22**, which is adjacent to the inside top of the upper housing section, is depressed, as shown in FIG. 6. This applies pressure on the punch cap **23** and compresses the punch spring **24**. The bottom of the punch spring **24** is compressed against the upper end **26** of the cartridge housing **19**. Just inside the upper end **26** of the cartridge housing **19**, the lower end of the punch rod **25** preferably flares out over the top of the cartridge **20**. This punch rod flange **39** abuts the top of the cartridge housing. In an alternate embodiment, the punch cap and the punch button are one piece. Thus, the punch mechanism **18** comprises: the punch cap **23** and/or punch button **22**, the punch spring **24**, and the punch rod **25**.

As shown in FIG. 6, when the punch rod **25** is depressed, the nail polish cartridge **20** is pushed downward. Since the dispenser mechanism **21** is rigidly attached to the lower end of the cartridge **20**, the dispenser shaft **32** is pushed downward. The bottom edge of the dispenser sheath **34** abuts the top of a circular ridge **40** that extends outwardly from the inside wall of the applicator in a perpendicular direction. In the center of the ridge is a chamber opening **41** large enough for the jaws to fit through. When the dispenser mechanism is in a closed position, as shown in FIGS. 4 and 5, the jaws **36** are closed and do not extend through the chamber opening **41**. When the dispenser mechanism is in an open position, as shown in FIG. 6, the jaws **36** are open and extend slightly into the chamber opening **41**. The chamber opening is at the top of a cylindrical brush chamber **42**. A brush aperture **43** at the lower end of the brush chamber **42** opens to the nail polish brush **12**. When the nail polish brush **12** is lowered, as shown in FIGS. 5 and 6, it extends through a housing aperture **44** in the bottom end of the lower housing section **15**. When it is retracted, the brush **12** is stored within

a hollow **45** in the lower portion of the lower housing section **15**, as shown in FIG. 4. The housing aperture can optionally have a thin, flexible rubber gasket around its circumference to protect the bristles when the brush is retracted, and to limit the exposure of the bristles to air, which may cause them to harden.

Continuing with FIGS. 4 through 6, when the dispenser shaft **32** is pushed down, the dispenser spring **33** is compressed. The dispenser sheath **34** remains pressed against the ridge **40** and is drawn back as the jaws **36** thrust forward. The jaws **36** drop down slightly into the brush chamber, as shown in FIG. 6. The polish drips down from the cartridge into the hollow dispenser shaft **32**. Since the dispenser sheath **34** is drawn back, the jaws **36** are no longer held closed. The jaws separate slightly, which allows a drop of nail polish to be emitted from the gap between the jaws. The drop of nail polish falls by gravity to the bottom of the brush chamber **42**. The nail polish then drips through the brush aperture **43** at the bottom of the brush chamber **42** into the nail polish brush **12**. Thus, a pre-determined amount of nail polish drips onto the bristles of the brush each time the user presses down on the top of the applicator. The brush bristles preferably surround the brush aperture **43**, so that the polish is evenly distributed through the bristles. Also, the physical action of brushing the applicator's brush **12** on a nail draws the drops of polish down through the bristles.

The size of the space between the jaws **36**, and the diameter of the brush aperture **43** are calibrated. This assures that the nail polish is emitted one drip at a time, and the amount of nail polish extruded to the brush **12** is enough to polish one or two nails, but is not so much that it drips off the end of the brush **12**. However, the user is in control of the amount of nail polish emitted onto the brush. If the user desires a greater amount of nail polish, she or he can push down on the top of the applicator **10** more frequently, or push the top down and hold it momentarily. The brush bristles are evenly coated, and the user can achieve a thin, even coating on the nail, which dries more quickly and evenly. The small sized brush of the present applicator and less nail polish on the brush means more precise application is possible. There is no need to plunge a brush into a nail polish bottle, coming up with varying amounts of polish, or to wipe the brush on the neck of the polish bottle to clean it off. Spilling is also avoided.

The main housing of the applicator is preferably weighted slightly (a few ounces) to steady and balance the applicator in the user's hand. This facilitates nail polish application.

Continuing to refer to FIGS. 4 through 6, the position (first, and second; raised and lowered) of the brush **12** is controlled by rotation of the upper housing section **14**. Inside the lower housing section **15** is a rotatable drum **46**. The rotatable drum **46** is closely and slidably positioned in a rotatable drum housing **47**, which fits closely inside the lower housing section **15**. The brush is affixed to the end of the rotatable drum. The user twists the upper and lower housing sections relative to one another, which causes the rotatable drum to rotate inside the rotatable drum housing, as shown in FIGS. 4 and 5, which lowers or raises the brush **12**, depending on the direction of the rotation (see below).

As shown in FIGS. 4 through 6, the ridge **40**, which is horizontally positioned in comparison to the vertical orientation of the main housing **11**, is continuous with, and extends in a perpendicular, inward direction from, the bottom of the rotatable drum **46**. When the upper housing section is rotated, preferably in a clockwise direction, the rotating drum housing **47** also turns. This causes the rotat-

able drum **46** to move in a downward direction, which moves the brush **12** out through the housing aperture **44**, as shown in FIG. 5. When the upper housing section **14** is turned in an opposite direction, usually counterclockwise, the rotatable drum housing **47** turns, and the rotatable drum **46** moves in an upward direction, which rotates the brush **12** back into the hollow **45** in the lower portion of the lower housing section **15**, as shown in FIG. 4. The brush **12** is preferably kept inside the hollow **45** when it is not in use in order to keep the brush bristles clean and soft. It is recommended that the brush **12** be cleaned prior to retracting it. A removable end cap **17** for attachment over the housing aperture **44** is recommended (see FIG. 3).

The preferred embodiment shown in FIGS. 4-6 also comprises an O-ring **48** which encircles the inside of the lower housing section **15** at approximately the same level as the top of the retracted brush **12**. The O-ring **48** provides a hollow for the brush to fit within. The O-ring allows the brush chamber to move up and down. The entire applicator is designed to provide an air tight environment for the nail polish. Nail polish contains certain solvents which easily evaporate into the ambient air when a container of nail polish is opened. Without meaning to be bound by theory, it is believed that the present applicator is relatively air tight, which helps to prevent the nail polish inside from hardening. This prevents clogging of apertures within the applicator and keeps the nail polish within the applicator from becoming thick and unusable. The nail polish within the present cartridges thus performs optimally for a longer period, and lasts a longer time inside the cartridge than nail polish in conventional nail polish containers.

In various forms of the invention, the cartridge **20** and dispenser shaft **32** are preferably made of a plastic material that is resistant to damage by solvents over time. Suitable plastic materials for use herein do not adhere to nail polish, so the nail polish is less likely to harden and stick to the walls of the dispenser shaft and cartridge. Most preferred for use herein is ultra high molecular weight polyethylene. The upper and lower housing sections can be made of plastic, metal (e.g., aluminum, stainless steel), or other suitable materials.

Referring to FIGS. 7 and 8, the lower end of the dispenser shaft **32** can be divided into two parts, forming two jaws **36**, as shown in FIG. 7. Three jaws are alternatively formed where the dispenser shaft has been divided into three parts, as shown in FIG. 8. FIGS. 7 and 8 show alternate embodiments, as viewed from outside the jaws looking in. The jaws **36** are shown in a closed position and are surrounded by the dispenser sheath **34** in FIGS. 7 and 8. The end of the dispenser shaft may be divided to form other shapes, such as multiple divisions forming a star-shaped opening. Alternatively, the jaws can be a separate component attached to the lower end of the dispenser shaft, rather than being formed by a split in the end of the dispenser shaft.

Thus, the applicator **10** includes: (a) an elongated, hollow, generally pen-shaped main housing **11** having an aperture at one axial extremity; (b) an elongated cartridge housing disposed within an upper portion of the main housing; (c) a nail polish cartridge comprising a central chamber for holding a supply of liquid nail polish, the nail polish cartridge having a first, upper end and an opposite, second, lower end, the cartridge being disposable within the cartridge housing **19**; (d) a brush **12** having a plurality of bristles for applying nail polish; (e) a mechanism **21** for dispensing nail polish from the nail polish cartridge in increments; and (f) a mechanism for controlling the discharge of nail polish from the nail polish cartridge onto the brush **12**. The nail polish

dispensing mechanism has a first position in which nail polish is contained within the cartridge and is not dispensed, and a second position in which nail polish is dispensed from the cartridge through the housing aperture onto the brush 12.

The brush 12 is preferably mounted for axial movement between a first position inside the lower housing section 15, as shown in FIG. 4, and a second position extending from the lower housing section 15, as shown in FIG. 5. The applicator 10 preferably includes: a rotatable mechanism for axially translating the brush 12 between the first position within the lower housing section 15, and the second position extending outside the lower housing section. The rotatable mechanism for axially translating the brush most preferably includes a rotatable drum 46 within a rotatable drum housing 47 disposed within the lower housing section 15.

The nail polish cartridge 20 is at least partially disposed within the cartridge housing 19, the cartridge housing 19 is disposed within the upper housing section 14, and the lower housing section 15 houses the dispensing mechanism 21, and the brush 12 when the brush 12 is in the first position. The cartridge housing 19 preferably has vertically oriented, spaced apart ribs 27 on its outer surface, as shown in FIG. 3, which correspond to similar ribs 27b along the inside surface of the upper housing section 14, as shown in FIG. 3b. At least one, most preferably all, of the ribs 27 on the cartridge housing 20 fits between at least one, most preferably all, of the ribs on the upper housing section 14.

Regarding (f) above, the control mechanism preferably includes a button or lever that is accessible to a user. A preferred mechanism for controlling the discharge of nail polish from the nail polish cartridge 20 is a punch mechanism 18 having a first position in which nail polish is not dispensed, as shown in FIG. 4, and a second position in which nail polish is dispensed from the nail polish cartridge 20 onto the brush 12, as shown in FIG. 6. The punch mechanism 18 preferably includes: (1) a punch cap 23 or punch button 22 in contact with an upper end of the main housing 11; (2) a punch rod 25 having an upper end and an opposite lower end; and (3) a punch spring 24 wrapped around at least a portion of the punch rod 25, as shown in FIGS. 4 through 6. A lower end of the punch spring 24 contacts an upper end of the cartridge housing 19, as shown in FIGS. 4-6. The upper end of the punch rod 25 contacts the punch cap 23 or punch button 22, and the lower end of the punch rod 25 contacts an upper end of the nail polish cartridge 20.

A preferred nail polish dispenser mechanism includes: (1) a hollow dispenser shaft 32; (2) a dispenser spring 33 movably wrapped around the dispenser shaft 32; and (3) a movable sheath 34 closely encircling at least a lower end of the dispenser shaft, as illustrated in FIGS. 4-6. An upper end of the dispenser shaft 32 is adapted for joining with a lower end 30 of the nail polish cartridge 20, and a lower end of the dispenser shaft 32 is divided to form a set of jaws 36.

Referring to FIG. 9, an alternate embodiment of the nail polish cartridge 20 is illustrated. Here, the removable cartridge 20 is refillable rather than being disposable. Thus, the nail polish cartridge can be either replaceable and disposable, as shown in FIGS. 4-6, or refillable, with a detachable cap at its upper end, as shown in FIG. 9.

To refill, the cartridge cap 49 is removed from the cartridge 20, as shown in FIG. 9. The cartridge cap 49 can screw or snap into an aperture at the top of the cartridge. A small funnel (not shown) can be used to fill the cartridge with nail polish from a supply bottle. The refillable cartridge is advantageous in that the user can pour only enough nail

polish into the cartridge to do the job at hand. For example, a customer whose fingernails were recently polished may have marred the nail polish on one or two of her nails. The present invention enables the manicurist to pour only enough polish into the refillable cartridge to replace the polish on those nails. There is thus less wasted nail polish. Another benefit of the refillable cartridge is that the user can choose her favorite nail polish brand or color to pour into the nail polish cartridge.

Referring to FIG. 10, an alternate embodiment of the applicator 10 includes a locking mechanism. For the purpose of illustration, a simplified upper portion of the applicator is shown. The locking mechanism can be used to fix the upper housing section 14 in place when the applicator 10 is not in use. When the applicator is in a locked position, the upper housing section 14 will not descend. Polish will therefore not be dispensed, or leak out, when the applicator is in a locked position. This minimizes chances that the applicator will leak, for example, when it is placed in a purse, or when a young child attempts to push in the top. The locking mechanism is comprised of lower lock tabs 50, which project outwardly from the outside of the upper portion of the lower housing section 15 just below the band 37. There are preferably two lower lock tabs 50 at the same location on opposite sides of the applicator 10. The locking mechanism also includes two corresponding upper lock tabs 51, which extend inwardly from the inside of the lower portion of the upper housing section 14, as shown in FIG. 10.

As shown in FIG. 10, when the lower lock tabs 50 are aligned with the upper lock tabs 51, the tabs prevent the upper housing section 14, which extends closely over the cartridge housing 19, from being moved in a downward direction, so the applicator 10 is locked. To unlock the applicator, a user turns the upper housing section 14 a quarter turn or so clockwise or counterclockwise. This moves the upper lock tabs 51 out of alignment with the lower lock tabs 50. When the applicator is thereby unlocked, the upper housing section can be depressed, which causes polish to be dispensed.

The applicator herein can be adapted for use by young girls or pre-teens by enlarging the housing somewhat. For example, a preferred embodiment of an applicator for use by an adult has an upper housing section midsection with a diameter of between about $\frac{1}{4}$ and $\frac{1}{2}$ inch, while the upper housing section of an applicator for use by younger girls can have a diameter of between about $\frac{1}{2}$ and $\frac{3}{4}$ inch. Applicators for the younger market are preferably substantially clear or translucent, or brightly colored.

Referring to FIG. 11, an alternate embodiment, which is disposable and particularly well-suited for the youth market, has a punch mechanism 18 and a dispenser mechanism 21, but no rotating mechanism for causing the brush 12 to ascend and descend. In this embodiment, there is no separate rotatable drum or rotatable drum housing. Instead of twisting the upper housing section to align the upper and lower lock tabs, in this simplified embodiment the entire upper housing section is detached and replaced in an aligned position to lock the applicator for use. Conversely, to unlock the applicator for use, the upper housing section is replaced so that the upper and lower lock tabs are not aligned. Since the brush does not move up and down in this embodiment, there is no need for an O-ring, hollow in the lower portion of the lower housing section, or aperture in the housing for the brush to fit through. Therefore, the lower housing section is greatly simplified. The ridge 40 extends from opposite sides of the lower housing section 15 toward the center of the applicator 10. For this embodiment, the punch mechanism 18 and dispenser mechanism 21 are as described herein.

Continuing to refer to FIG. 11, the bristles of the brush 12 have a first end 52 mounted in the main housing 11, and an opposite, second end which is a free end 53, as in previous embodiments described herein. In any embodiment, the applicator 10 may include a dispenser sheath 34 which extends the length of the dispenser shaft 32 from the bottom of the jaws 36 to just under the collar 30 of the cartridge 20, which is where the dispenser shaft 32 attaches to the cartridge 20. This cylindrical sheath 34, which is shown in FIG. 11, is longer than the dispenser sheath shown in FIGS. 4-6, and movably extends outside the dispenser spring 33.

Referring to FIGS. 12 and 13, the rotation mechanism allows a user to lower the brush 12 from inside the lower housing section 15 by twisting the upper and lower housing sections 14, 15 in opposite directions. In a preferred embodiment of the applicator 10, the rotation mechanism comprises the rotatable drum housing 47 in the rotatable drum 46 (see FIGS 4b-6b), which is located in the lower housing section 15. The rotatable drum housing extends substantially the length of the lower housing section and has a hollow for the brush in its lower portion. The lower housing section has along its inside wall a swirled, indented track 57 that spirals around and down the inside wall, as shown in cross-section in FIG. 12. The rotatable drum comprises two straight, vertical, cut-out tracks 55 extending down on opposite sides. The straight track 55 curves and has a deadend 54 at the top and bottom of each straight track, as shown in FIG. 13. The rotatable drum housing has two small button projections 56, which project through the straight, vertical cut-out tracks 55 from opposite, exterior sides of the rotatable drum. The brush 12 is attached to the lower end of the rotatable drum housing. Each button projection 56 projects through a straight rack 55. The unattached ends of the button projections extend through the two straight, vertical tracks on either side of the rotatable drum and into the swirled track 57 in the wall of the lower housing. When the rotatable drum is rotated, the rotatable drum housing moves up and down the straight tracks 55 in the rotatable drum. The button projections 56 moving along the swirled track in the lower housing causes the rotatable drum to revolve, or rotate. This causes the brush 12 to move in and out of the lower housing section 15. At the bottom or top of each straight track 55, each button projection 56 locks into the deadend 54, as shown in FIG. 13. This locks the brush 12 into place.

An alternate embodiment shown in FIGS. 4c through 6c does not include a rotatable drum housing. In this case, button projections 56 project through opposite sides of the rotatable drum. The buttons extend from the ridge 40 through a straight track 55 in the rotatable drum 46. The unattached ends of the button projections extend into the swirled, indented track on either side of the inside wall of the lower housing. When the drum is rotated, the buttons move up and down the straight tracks in the drum using the swirled track in the wall of the lower housing to move when turned.

Another alternate embodiment with a rotatable drum housing includes one button projection 56, rather than two, on the outside of the rotatable drum 46, a single swirled track 57 in the rotatable drum housing 47, and no straight track. The button projection projects into and moves along the single swirled, cut-out track 57. The rotatable drum housing 47 moves up and down within the rotatable drum 46 as the button projection 56 moves along the swirled track. This causes the brush 12, which is attached to the lower end of the rotatable drum housing, to rotate in and out of the applicator.

From this description, it is obvious that the applicator can be held with one hand for an entire nail painting sequence. The applicator is ready for use on the nails as soon as the end cap is removed and the brush is extended.

Another alternate embodiment, as shown in FIG. 14, further includes a reservoir 58 for holding nail polish remover within the main housing 11, and a mechanism for stopping the flow of nail polish and dispensing the nail polish remover, so that the nail polish remover is supplied to the nail polish brush instead of the nail polish. This user-controlled option is useful for repairing a botched polish job on a nail (e.g., polish that has smeared over the nail cuticle), and for cleaning the brush after a nail polish job (e.g., after finishing with a manicure customer). The reservoir is preferably below the nail polish cartridge, and may be a division of the nail polish cartridge. Any type of liquid nail polish remover, including acetone, is suitable for use in the reservoir. The reservoir must be made of a material which is resistant to the effects over time of the nail polish remover contained in it.

One embodiment of this applicator with both nail polish and remover has a separate dispenser mechanism attached to the outside of the main housing, with a detachable, replaceable sponge end. An alternative embodiment of the applicator with both polish and remover accommodates two separate side-by-side or end-to-end removable cartridges, one for holding nail polish and one for holding nail polish remover. Rotation of the upper housing section clockwise or counterclockwise by the user determines which cartridge is tapped. Alternatively, two or more movable slide buttons on the exterior of the applicator can be moved to cause whichever cartridge is desired for use to slide into place for use. In the latter embodiment, each narrow cartridge would hold a different nail polish color, or polish remover. Each color-coded slide button would activate one cartridge.

From the foregoing it can be realized that the described device of the present invention may be easily and conveniently utilized as a nail polish applicator. It is to be understood that any dimensions given herein are illustrative, and are not meant to be limiting.

While preferred embodiments of the invention have been described using specific terms, this description is for illustrative purposes only. It will be apparent to those of ordinary skill in the art that various modifications, substitutions, omissions, and changes may be made without departing from the spirit or scope of the invention, and that such are intended to be within the scope of the present invention as defined by the following claims. It is intended that the doctrine of equivalents be relied upon to determine the fair scope of these claims in connection with any other person's product which fall outside the literal wording of these claims, but which in reality do not materially depart from this invention.

Without further analysis, the foregoing will so fully reveal the gist of the present invention that others can, by applying current knowledge, readily adapt it for various applications without omitting features that, from the standpoint of prior art, fairly constitute essential characteristics of the generic or specific aspects of this invention.

What is claimed is:

1. An applicator for dispensing and applying nail polish, the applicator comprising:

- (a) an elongated, hollow, generally pen-shaped main housing having all aperture at one axial extremity;
- (b) an elongated cartridge housing disposed within an upper portion of the main housing;
- (c) at least one nail polish cartridge comprising a central chamber for holding a supply of liquid nail polish, the nail polish cartridge having a first, upper end and an opposite, second, lower end, the cartridge being disposable within the cartridge housing;

- (d) a brush having a plurality of bristles for applying nail polish, each bristle having a first end mounted in the main housing and an opposite, second end which is a free end;
- (e) a mechanism for dispensing nail polish from the nail polish cartridge in increments, the nail polish dispensing mechanism having a first position in which nail polish is contained within the cartridge and is not dispensed, and a second position in which nail polish is dispensed from the cartridge through the housing aperture onto the brush;
- (f) a mechanism for controlling the discharge of nail polish from the nail polish cartridge onto the brush; and
- (g) a rotatable mechanism for axially translating the brush between the first position within the lower housing section, and the second position extending outside the lower housing section;
- wherein the main housing comprises an elongated upper housing section having an opening at one axial extremity, and a lower housing section having an opening at one axial extremity, the upper and lower housing sections being detachably joined together at the openings; the brush being mounted for axial movement between a first position inside the lower housing section, and a second position extending from the lower housing section;
- wherein a band connectable to a drum housing within the main housing is rotatable with the rotatable upper housing section; the brush being movable between the first and second positions with rotation of the upper housing section; and
- wherein the nail polish cartridge is at least partially disposed within the cartridge housing, the cartridge housing is disposed within the upper housing section, and the lower housing section houses the dispensing mechanism, and the brush in the first position.

2. A nail polish applicator according to claim 1, wherein the mechanism for controlling the discharge of nail polish from the nail polish cartridge comprises a punch mechanism having a first position in which nail polish is not dispensed, and a second position in which nail polish is dispensed from the nail polish cartridge onto the brush.

3. A nail polish applicator according to claim 2, wherein the punch mechanism comprises: (1) a punch cap or punch button in contact with an upper end of the main housing; (2) a punch rod having an upper end and an opposite lower end, the upper end of the punch rod contacting the punch cap or punch button, the lower end of the punch rod contacting an upper end of the nail polish cartridge; and (3) a punch spring wrapped around at least a portion of the punch rod, a lower end of the punch spring contacting an upper end of the cartridge housing.

4. A nail polish applicator according to claim 1, wherein the outside surface of the cartridge housing comprises vertically oriented, spaced apart ribs which correspond to similar ribs along the inside surface of the upper housing section, and wherein at least one of the ribs on the cartridge housing fits between at least one of the ribs on the upper housing section.

5. A nail polish applicator according to claim 1, wherein the nail polish cartridge is replaceable and disposable.

6. A nail polish applicator according to claim 5, wherein the mechanism for controlling the discharge of nail polish from the cartridge comprises a button accessible to a user.

7. A nail polish applicator according to claim 1, wherein the nail polish cartridge is refillable and comprises a detachable cap at its upper end.

8. An all-in-one applicator for dispensing and applying nail polish comprising:

- (a) an elongated, hollow, generally pen-shaped main housing having an aperture at one axial extremity;
- (b) an elongated cartridge housing disposed within an upper portion of the main housing;
- (c) at least one nail polish cartridge comprising a central chamber for holding a supply of liquid nail polish, the nail polish cartridge having a first, upper end and an opposite, second, lower end, the cartridge being disposable within the cartridge housing;
- (d) a brush having a plurality of bristles for applying nail polish, each bristle having a first end mounted in the main housing and an opposite, second end which is a free end;
- (e) a mechanism for dispensing nail polish from the nail polish cartridge in increments, the nail polish dispensing mechanism having a first position in which nail polish is contained within the cartridge and is not dispensed, and a second position in which nail polish is dispensed from the cartridge through the housing aperture onto the brush; the nail polish dispenser mechanism comprising: (1) a hollow dispenser shaft; (2) a spring movably wrapped around the dispenser shaft; and (3) a movable sheath closely encircling at least a lower end of the dispenser shaft; wherein an upper end of the dispenser shaft is attachable to a lower end of the nail polish cartridge, and a lower end of the dispenser shaft is divided to form a set of jaws; and
- (f) a mechanism for controlling the discharge of nail polish from the nail polish cartridge onto the brush; wherein a band connectable to a drum housing within the main housing is rotatable with an upper section of the main housing; the brush being enabled to extend or retract by rotation of the upper housing section.

9. A nail polish applicator according to claim 1, wherein the rotatable mechanism for axially translating the brush comprises a rotatable drum within the rotatable drum housing, the rotatable drum housing being disposed within the lower housing section.

10. A nail polish applicator according to claim 9, wherein the rotatable drum housing comprises two button projections projecting from opposite sides of the rotatable drum housing through straight, generally vertical cut-out tracks in the rotatable drum, the brush being affixed to a lower end of the rotatable drum housing; and wherein the lower housing section comprises a swirled, indented track spiraling down along its inside wall, each button projection having an end which movably projects through one of the straight tracks into the swirled track for guiding the rotatable drum housing down or up within the rotatable drum.

11. A nail polish applicator according to claim 10, wherein the rotatable drum further comprises two substantially identical straight tracks on its opposite sides, and wherein each button projection extends through a straight track and into the swirled track.

12. A nail polish applicator according to claim 9, wherein the rotatable drum comprises a button projection projecting from an upper end of the rotatable drum, the brush being affixed to a lower end of the rotatable drum; and wherein the rotatable drum housing comprises a swirled, indented track spiraling down along its inside wall, the button projection having an unattached end which movably projects into the swirled track and guides the rotatable drum down or up within the rotatable drum housing.

15

13. An all-in-one nail polish applicator, comprising:
- (a) an elongated, hollow, generally pen-shaped main housing having an aperture at one axial extremity; the main housing being comprised of an elongated upper housing section having an opening at one axial extremity, and a lower housing section having an opening at one axial extremity, the upper and lower housing sections being detachably joined together at the openings;
 - (b) an elongated cartridge housing disposed within an upper portion of the main housing;
 - (c) at least one nail polish cartridge comprising a central chamber for holding a supply of liquid nail polish, the nail polish cartridge having a first, upper end and an opposite, second, lower end, the cartridge being disposable within the cartridge housing;
 - (d) a brush having a plurality of bristles for applying nail polish, each bristle having a first end mounted in the main housing and an opposite, second end which is a free end;
 - (e) a mechanism for dispensing nail polish from the nail polish cartridge in increments, the nail polish dispensing mechanism having a first position in which nail

16

- polish is contained within the cartridge and is not dispensed, and a second position in which nail polish is dispensed from the cartridge through the housing aperture onto the brush;
- (f) a mechanism for controlling the discharge of nail polish from the nail polish cartridge onto the brush; and
 - (g) a locking mechanism comprised of: at least two lower lock tabs, which project outwardly from the outside of an upper portion of the lower housing section; and at least two corresponding upper lock tabs, which extend inwardly from the inside of a lower portion of the upper housing section; wherein, when the lower lock tabs are aligned with the upper lock tabs, the lock tabs prevent the upper housing section from being moved in a downward direction;
- wherein a band connectable to a drum housing within the main housing is rotatable with the rotatable upper housing section; the brush being enabled to extend or retract by rotation of the upper housing section.
14. A nail polish applicator according to claim 1, further comprising a reservoir for holding nail polish remover within the main housing adjacent to the nail polish cartridge.

* * * * *