



US006530249B1

(12) **United States Patent**  
**Burkhead**

(10) **Patent No.:** **US 6,530,249 B1**  
(45) **Date of Patent:** **Mar. 11, 2003**

(54) **HITCH BALL LOCKING PLATE**

(76) Inventor: **Robert G. Burkhead**, 819 Boone  
White Rd., Leitchfield, KY (US) 42754

(\*) Notice: Subject to any disclaimer, the term of this  
patent is extended or adjusted under 35  
U.S.C. 154(b) by 0 days.

(21) Appl. No.: **10/023,503**

(22) Filed: **Dec. 13, 2001**

(51) **Int. Cl.**<sup>7</sup> ..... **E05B 73/00**

(52) **U.S. Cl.** ..... **70/14; 70/232; 70/258;**  
280/507

(58) **Field of Search** ..... 70/14, 229-232,  
70/258; 280/416.1, 507, 509, 511, 512

(56) **References Cited**

**U.S. PATENT DOCUMENTS**

2,571,349 A	*	10/1951	Eckles	70/14 X
2,785,564 A	*	3/1957	Rossi	70/232
3,237,969 A	*	3/1966	Geresy	280/507
3,391,555 A	*	7/1968	Mamo	70/258
4,066,231 A		1/1978	Bahner et al.	
4,141,233 A	*	2/1979	Reyes	70/232
4,212,175 A		7/1980	Zakow	
4,239,430 A		12/1980	Groene	
4,305,266 A		12/1981	Lockwood	
4,538,827 A	*	9/1985	Plifka	70/14 X
4,648,618 A	*	3/1987	Utman et al.	70/258 X
4,691,935 A		9/1987	Brandt	
4,730,841 A	*	3/1988	Ponder	70/258 X
4,776,607 A	*	10/1988	Richter et al.	280/507
5,018,759 A	*	5/1991	Villalon et al.	280/507

5,052,203 A	*	10/1991	Van Cuyk	70/232
5,094,423 A	*	3/1992	Almquist et al.	70/58 X
5,147,096 A	*	9/1992	Rogers	280/507
5,297,407 A	*	3/1994	Tarr	70/232
5,421,601 A	*	6/1995	Hinze et al.	70/232 X
5,700,024 A	*	12/1997	Upchurch	280/507
6,018,968 A	*	2/2000	Sides	70/14
6,135,482 A	*	10/2000	Larkin	280/416.1
6,139,043 A	*	10/2000	Gries et al.	280/511 X
6,149,359 A		11/2000	Cardona	
6,155,590 A	*	12/2000	Herrera et al.	280/511
6,217,054 B1	*	4/2001	Klimek et al.	280/511
6,393,874 B1	*	5/2002	Zapushek et al.	70/14
6,406,052 B1	*	6/2002	Bale	280/507
6,412,313 B1	*	7/2002	Bernstrom	70/14
6,412,314 B1	*	7/2002	Jenks	70/14

\* cited by examiner

*Primary Examiner*—Suzanne Dino Barrett  
(74) *Attorney, Agent, or Firm*—James E. Cole; Middleton  
Reutlinger

(57) **ABSTRACT**

A hitch ball locking plate for securing equipment in the bed of a truck, a trailer, or the like. The hitch ball locking plate comprises a first plate having a first guiding aperture. The first plate further comprises a second plate normal to the first plate and extending across the first plate. The second plate has a substantially semi-circular removed portion in communication with the first guiding aperture. Pivotably connected to the first plate is a locking bar which locks the first and second plate to a hitch ball in the bed of a truck, trailer, or the like. From this position, equipment and goods can be locked to the plate for security.

**28 Claims, 3 Drawing Sheets**

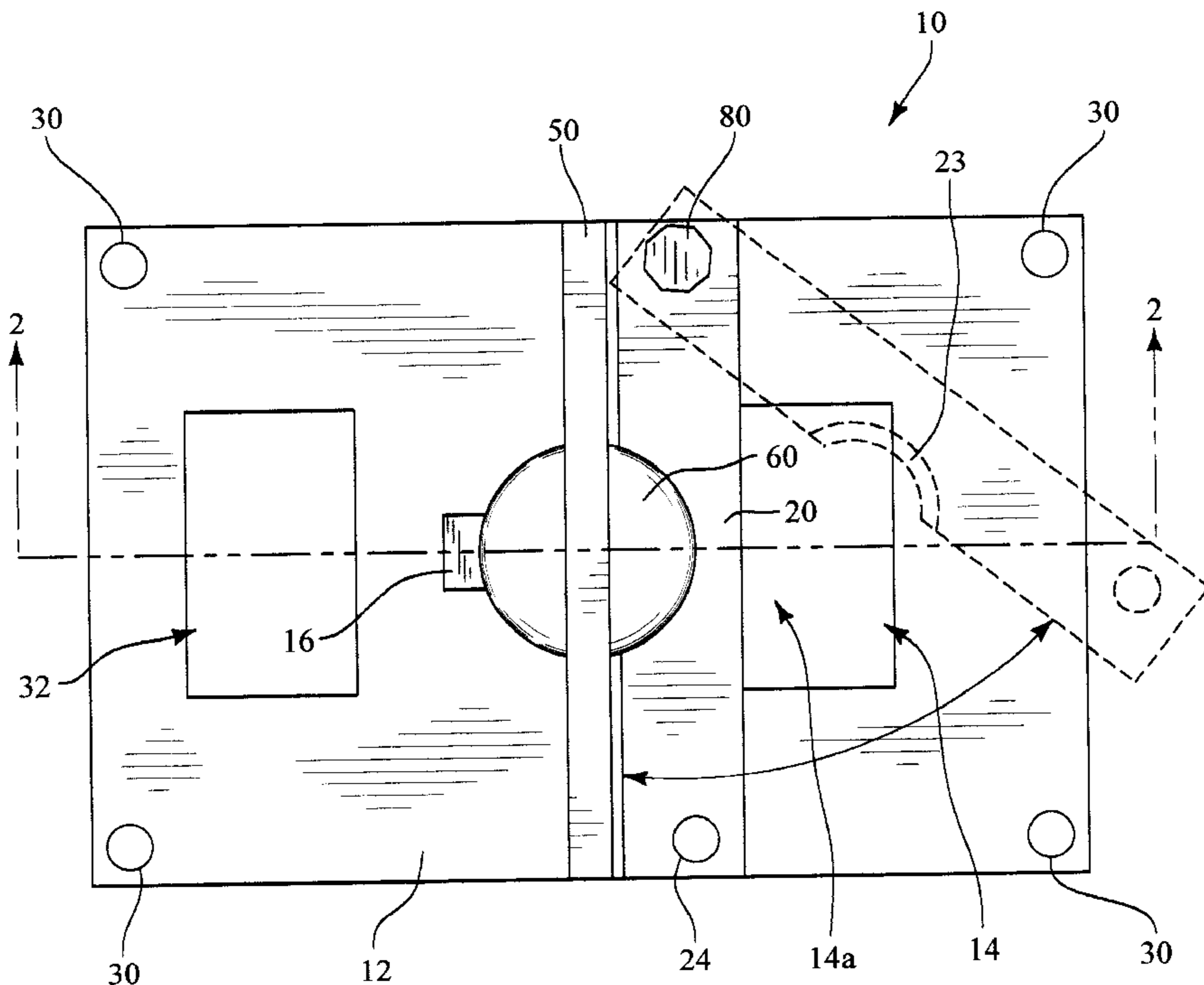

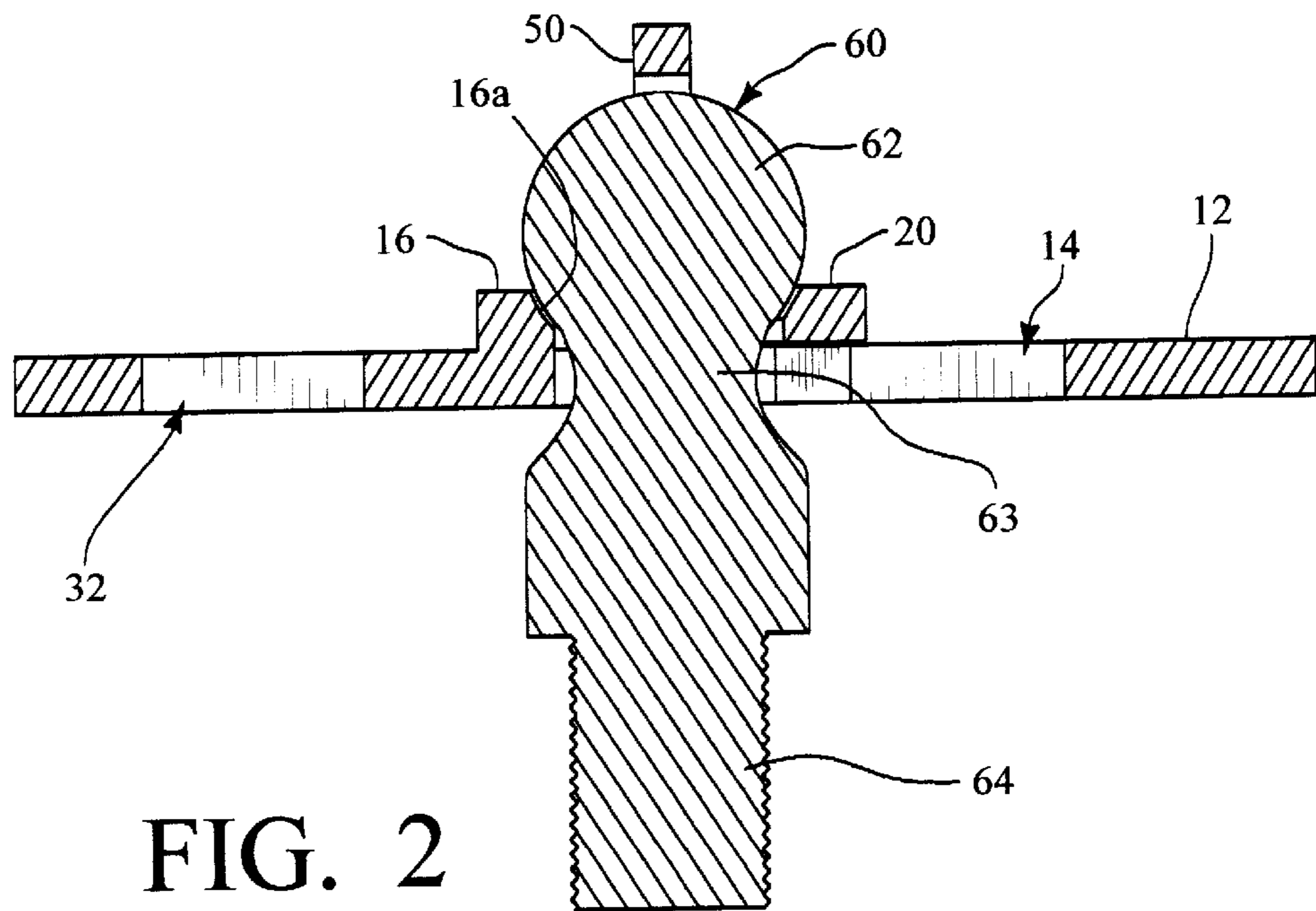
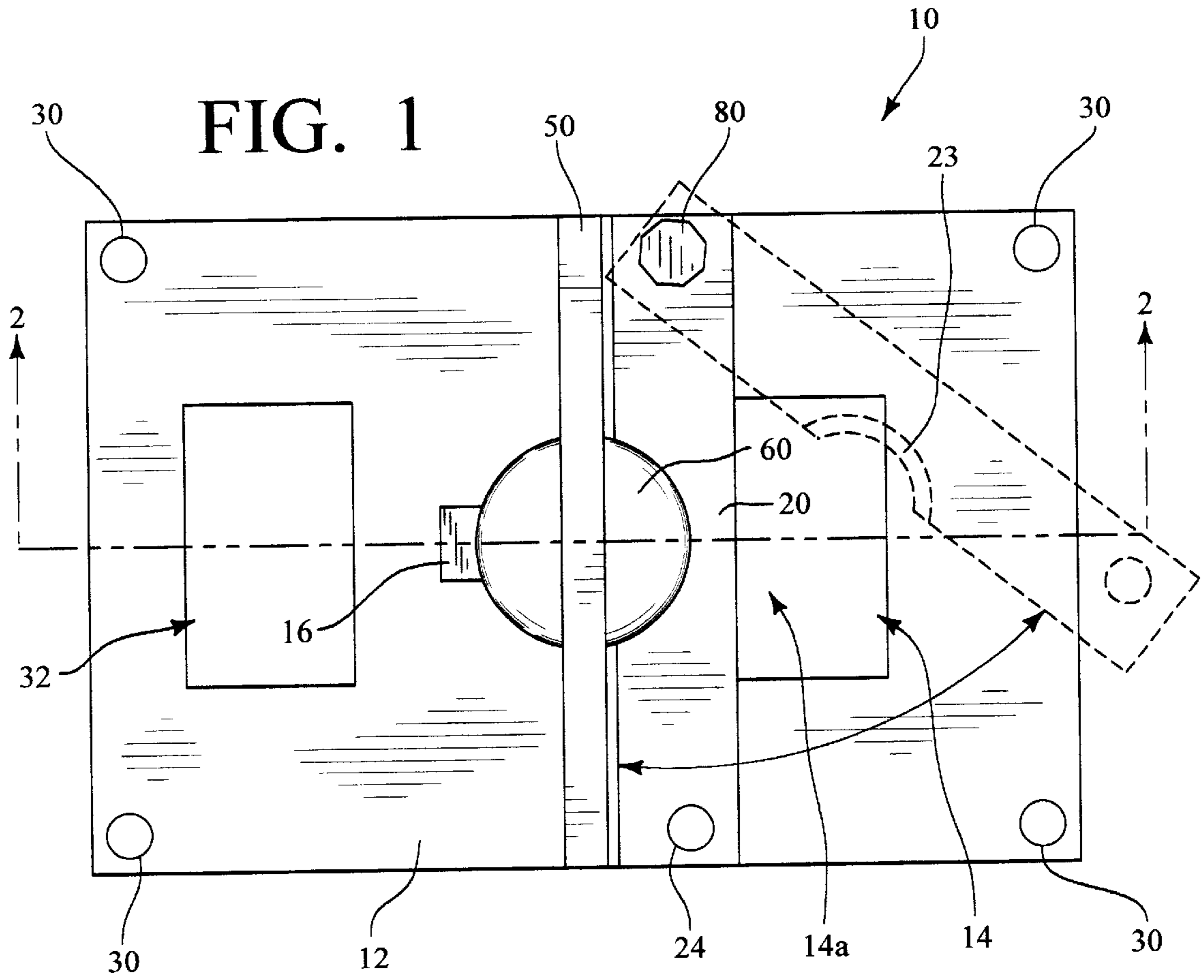

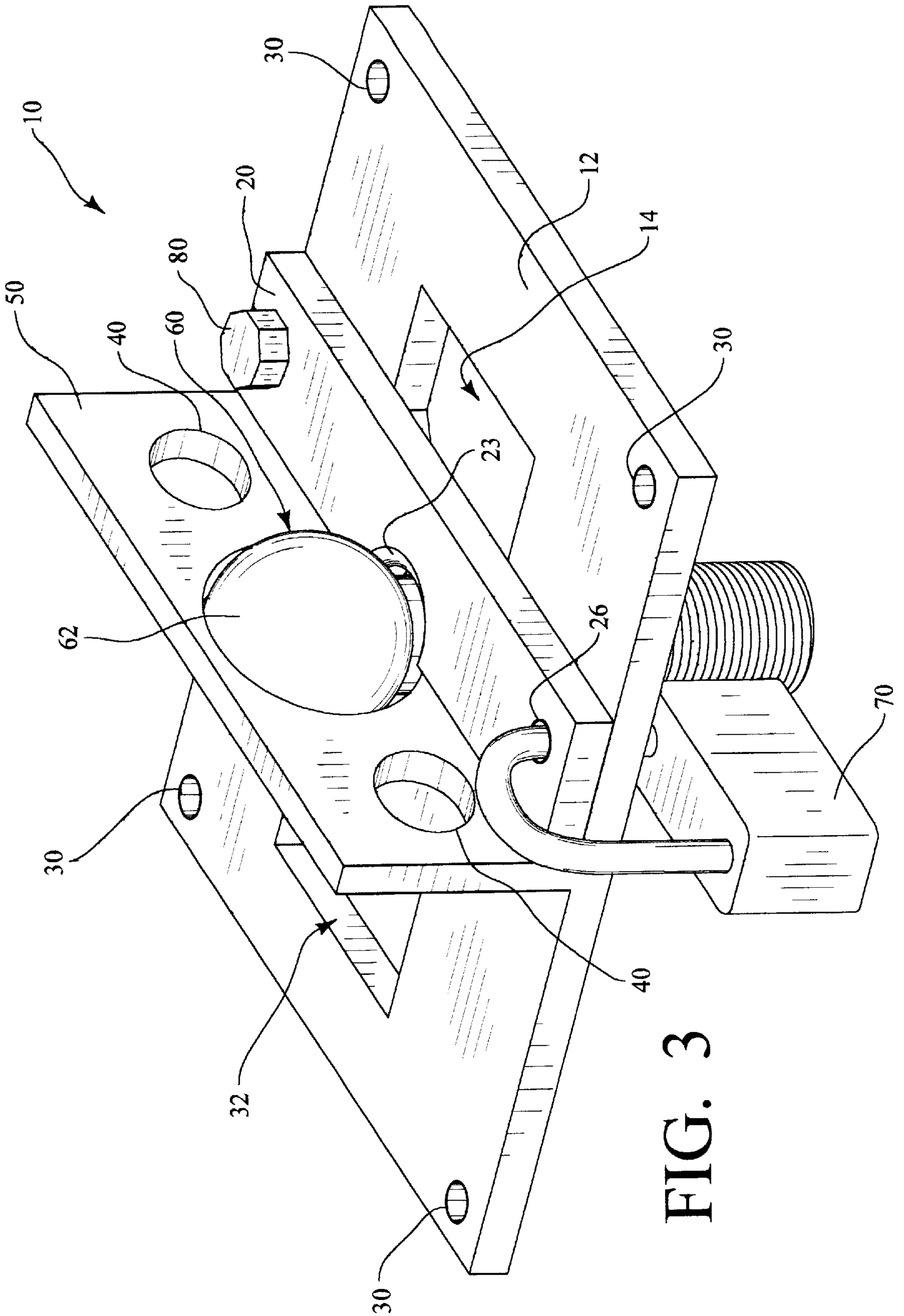

FIG. 3

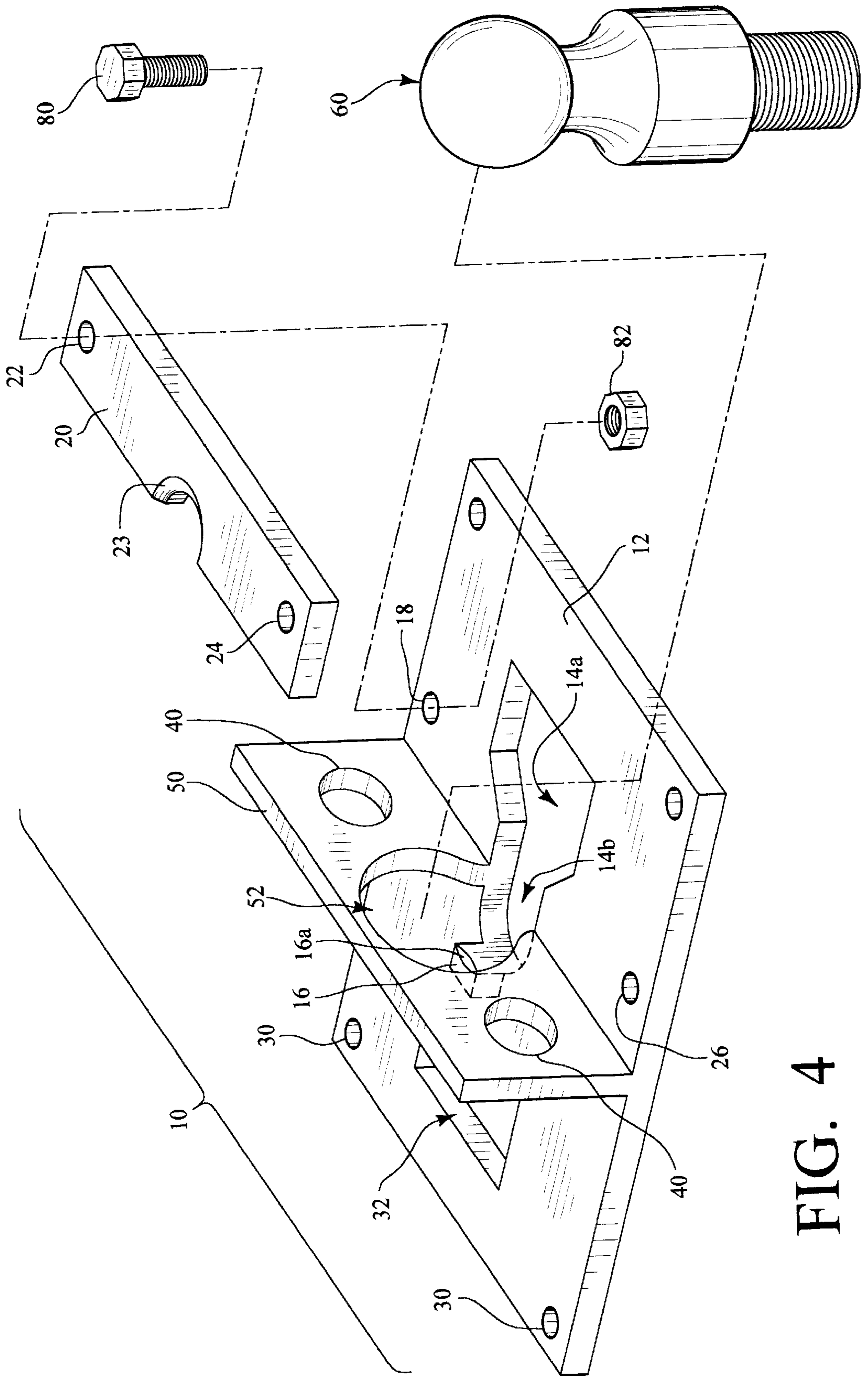

FIG. 4

## HITCH BALL LOCKING PLATE

## BACKGROUND OF THE INVENTION

## 1. Technical Field of the Invention

The present invention relates generally to a locking plate. More particularly the invention relates to a locking plate for a hitch ball mounted in the bed of a truck or trailer to which items can be secured such as lawn mowers, power equipment or any other equipment which might be easily stolen from the back of the truck or trailer if not secured.

## 2. Description of the Related Art

Many truck owners have a bedliner installed the bed of their truck. These bedliners protect the finish of the bed from abrasions caused by hauling materials therein. However, many of these bedliners cover holes that were placed in the bed of the truck for locking goods therein. Additionally, many of the truck manufacturers have stopped placing holes securing means in the metal beds of their trucks which could be used to secure goods to the therein. For these reasons new truck buyers are not afforded a way to secure goods within the bed of a truck which raises the possibility of theft of the goods placed therein. In the same way, people who use flat bed trailers often have difficulty securing or locking goods within the trailer and protecting them from theft.

In view of the deficiencies in known means for securing goods within a truck bed, it is apparent that a design is needed allowing a user to secure goods within the bed of a truck or a trailer. It is also preferable that the design allow securing of goods in a locked manner thereby reducing the incidence of theft of, for example, equipment from the truck or trailer.

## SUMMARY OF THE INVENTION

It is an object of the present invention to provide a locking plate.

It is a further objective of this invention to provide a locking plate for a hitch ball mounted to the bed of a truck or trailer.

It is still a further objective of this invention to provide a locking plate for securing removable goods to the bed of a truck while the plate is locked to a hitch ball installed to the bed of the truck or trailer.

An even further object of the present invention is to provide a platform for securing valuable items to the hitch ball of a vehicle, the platform removably affixed to the hitch ball.

One embodiment of a hitch ball locking plate, comprising a first plate having a centrally located positioning aperture having a wide and a narrow portion therein, a locking tab adjacent a narrow portion of the first aperture, and a locking bar pivotably attached to the first plate is described herein. The locking bar and locking tab each have opposed curved and beveled edges for positioning against a hitch ball. The hitch ball locking plate further comprises a second plate integral with the first plate and normal to the first plate. The second plate is centrally aligned across the first plate and above the narrow portion of the first aperture. The second plate has at least one aperture and one substantially semi-circular removed portion. The substantially semi-circular removed portion is operably communicating with the narrow portion of the guiding aperture.

The hitch ball locking plate is further comprising a first lock aperture in the first plate and a second lock aperture on the locking bar in alignment with the first locking bar

aperture. A lock can be placed through the first and second lock apertures to secure the locking plate to a hitch ball.

All of the above outlined objectives are to be understood as exemplary only and many more objectives of the invention may be gleaned from the disclosure herein. Therefore, no limiting interpretation of the objectives noted is to be understood without further reading of the entire specification, claims, and drawings included herewith.

## BRIEF DESCRIPTION OF THE DRAWINGS

The aspects and advantages of the present invention will be better understood when the detailed description of the preferred embodiment is taken in conjunction with the accompanying drawings, in which:

FIG. 1 shows a top view of the hitch ball locking plate of the present invention;

FIG. 2 shows a sectional view along line 2—2 of FIG. 1;

FIG. 3 shows a perspective view of the hitch ball locking plate of the present invention; and,

FIG. 4 shows an assembly view of the hitch ball locking plate of the present invention.

## DETAILED DESCRIPTION OF THE PREFERRED EMBODIMENT

The present invention will now be described in conjunction with the drawings, referring initially to FIGS. 1 and 3, which show a hitch ball locking plate 10 for mounting to a hitch ball 60, for instance a gooseneck ball hitch, in a flat bed truck, pick-up truck, or flat bed trailer (not shown).

The hitch ball locking plate 10 comprises a first plate 12 preferably formed of steel and having a first, positioning, or guiding aperture 14. The first plate 12 is substantially rectangular in the described embodiment, but may vary in shape. Preferably, the first plate 12 has a size of about 10"×11"× $\frac{3}{8}$ ", but may vary depending on the application. The first positioning or guiding aperture 14 has two portions, a wide portion 14a and a narrow portion 14b as best shown in FIG. 4. The hitch ball locking plate 10 must be positioned over a hitch ball 60 through the wide portion 14a before moving the locking plate 10 such that hitch ball 60 is positioned in the narrow portion 14b for proper locking. The narrow portion 14b of guiding or positioning aperture 14 prevents hitch ball locking plate 10 from slipping over the head of hitch ball 60 when the device is in a closed or locked position. The wide portion 14a of guiding aperture 14 is preferably sized to fit a ratchet strap hook. The ratchet strap can be used to secure goods having a length greater than the bed of the truck such as boards, pipes, and the like. Alternatively, aperture 14 may be used to in conjunction with chains, ropes, or cables to secure goods to the hitch ball locking plate 10.

Returning to FIG. 1, adjacent the narrow portion 14b of the first plate 12 and on a top surface thereof, is a locking tab 16. The locking tab 16 preferably has a substantially rectangular block type shape. Along an upper edge and adjacent the narrow portion 14b of the locking tab 16 is a curved beveled edge 16a as best seen in FIG. 4. The curved beveled edge 16a provides a close fit against the hitch ball 60 when the ball hitch locking plate 10 is in a locked position, as shown in FIG. 2. The locking tab 16 is preferably derived from of a piece of flat bar stock, although this size and shape may vary. As one skilled in the art will recognize the locking tab 16 provides a mechanism for placing a beveled edge against the hitch ball 60 thus allowing a tight and secure fit.

A second aperture 32 is located in the first plate 12. Second aperture 32 may be preferably sized to fit a hook of

a ratchet strap. Wide portion **14a** of guiding aperture **14** is preferably sized to also fit a ratchet strap hook such that guiding aperture **14** and second aperture **32** can be used in combination to secure pipe, timbers, boards, and the like with ratchet straps. Alternatively, aperture **14** may be used to in conjunction with chains, ropes, or cables to secure goods to the hitch ball locking plate **10**. In addition, the second aperture **32** also reduces the weight of the hitch ball locking plate **10**.

A plurality of lockdown apertures **30** are provided in a spaced configuration around a peripheral edge of the first plate **12**. The lockdown apertures **30** allow a lock arm to be inserted therethrough, for instance, also passing through a chain to lock a piece of equipment to the hitch ball locking plate **10**. Alternatively, a rope may be placed through the lockdown apertures **30** and tied to a piece of equipment. The size of the lockdown apertures may vary such that chains, bolt clevises, hooks, or the like may be used with the lockdown apertures.

At least one aperture is provided as a first pivoting or first pivot aperture **18**, shown in FIG. 4. The first pivot aperture **18** is aligned with a second pivot aperture **22** on locking bar **20**. A screw and nut, rivet, or preferably, a bolt and nut **80,82** are placed through the aligned apertures **18** and **22** to provide a pivotable connection between the locking bar **22** and the first plate **12**. Most preferably, the nut **82** is welded to the bolt **80** and the edges of the bolt **80** are cut or ground off so that a thief can not use a wrench or ratchet tool to loosen the nut **82** and bolt **80**. The locking bar **20** may be, substantially rectangular in shape having the second pivoting aperture **18** at a first distal end and a second lock aperture **24** at a second distal end. Of course one of ordinary skill in the art may utilize a number of known geometries for the locking bar and plate and these varying geometries are considered to fall within the teachings herein.

Along the upper edge of locking bar **20** closest to locking tab **16** is a beveled area **23**. The beveled area or edge **23** is preferably also curved such that the locking bar **20** fits closely against the ball hitch **60** in a closed position. The locking bar **20** is preferably made of steel such as from a piece of flat bar stock. As one skilled in the art will recognize, the beveled edge **23** should also be opposing the beveled edge **16a** of locking tab **16**.

In the closed position second lock aperture **24** of the locking bar **20** is aligned with first lock aperture **26** in first plate **12**. As shown in FIG. 3 a lock is placed through the aligned apertures **24,26** to secure the ball hitch locking plate **10** to ball hitch **60**, and therefore a truck, trailer or the like.

In addition to the first plate **12** and pivotably connected locking bar **20** is a second plate **50**, preferably welded to an upper surface of the first plate **12**. The second plate **50** is integral with and centrally located on the first plate **12** and has a substantially circular removed portion **52**. The removed portion **52** is located above the narrow portion **14b** of guiding or positioning aperture **14**. The removed portion **52** is operably communicating with narrow portion **14b** of first aperture **14**. As best seen in FIGS. 1 and 2, when ball hitch **60** is positioned in the narrow portion **14b** of guiding or positioning aperture **14**, ball hitch **60** moves within removed portion **52** of second plate **50**.

The second plate **50** also has at least one aperture locking **40**, and may have two as shown in FIGS. 3 and 4. The at least one locking aperture **40** is placed in the second plate **50** for connecting chains, ropes, and the like between removable equipment or goods in the truck or trailer and the hitch ball locking plate **10**.

A hitch ball **60** is also included in the device for connection to a truck bed or trailer. The hitch ball **60** has a head **62** at an upper end of a shaft preferably having a diameter of  $2\text{--}\frac{5}{16}$ ". At a lower end of the shaft are a plurality of threads **64** for connecting with a truck bed or trailer. Below the head **62** is a neck portion **63** having dimensions which allow it to fit within the narrow portion **14b** of guiding or positioning aperture **14**. When the hitch ball locking plate **10** is closed, one can see that the locking plate **10** is prevented from moving in three dimensions by the locking tab **16** and locking bar **20**, first plate **12**, and second plate **50**. This, in turn, secures the locking plate **10** to the truck, trailer, or the like.

In operation, the hitch ball **60** is threadably attached to a truck bed or trailer. The threads **64** of the hitch ball **60** may be directly threaded into the bed of the truck or trailer or threaded into a nut located beneath the bed of the truck or trailer on an underside.

With the locking bar **20** pivoted to an open position away from second plate **50**, the locking plate **10** is placed over the head **62** of hitch ball **60** with second plate **50** oriented in an upward position. The locking plate **10** is lowered on to the head **62** so that the head **62** extends through the wide portion **14a** of guiding or positioning aperture **14**. Next, the locking plate **10** is moved laterally so that the neck **63** of the hitch ball **60** is positioned within the narrowed portion **14b** of the guiding aperture **14**. The locking plate **10** should also be positioned so that the beveled portion **16a** of locking tab **16** has a close fit against head **62** of ball hitch **60**.

The locking bar **20** is next rotated to a closed position as shown in FIG. 3. The beveled edge **23** of locking bar **20** should be closely fit against the head **62** of the hitch ball **60** opposite locking tab **16**. With first lock aperture **26** and second lock aperture **24** aligned, a lock **70** is placed through both apertures and locked. In this position the lock **70** keeps the locking bar **20** in close relation with the hitch ball **60**. In addition equipment and goods in the bed of the truck or trailer can be attached by chain, rope, or other means to the locking plate **10**.

The foregoing detailed description is given primarily for clearness of understanding and no unnecessary limitations are to be understood therefrom for modifications will become obvious to those skilled in the art upon reading this disclosure and may be made without departing from the spirit of the invention and scope of the appended claims.

I claim:

1. A hitch ball locking plate, comprising:  
a first plate having a positioning aperture;  
a locking bar attached to said first plate;

a second plate integral with said first plate and normal to said first plate;

wherein said second plate is centrally aligned across said first plate and above a narrow portion of said positioning aperture.

2. The hitch ball locking plate of claim 1, wherein said second plate has at least one aperture and one substantially semi-circular removed portion.

3. The hitch ball locking plate of claim 1, further comprising a first lock aperture in said first plate and a second lock aperture on said locking bar in alignment with said first lock aperture.

4. The hitch ball locking plate of claim 1, wherein said positioning aperture is centrally located on said first plate.

5. The hitch ball locking plate of claim 1, wherein said locking bar is pivotably attached to said first plate.

6. The hitch ball locking plate of claim 1, a locking tab adjacent a narrow portion of said positioning aperture.

7. The hitch ball locking plate of claim 1, further comprising a plurality of lockdown apertures in a spaced configuration around a peripheral edge of said first plate.

8. A hitch ball locking plate, comprising:  
 a first plate having a positioning aperture located thereon;  
 said positioning aperture having a wide portion and a narrow portion;  
 a locking bar attached to said first plate and having a look aperture opposite a pivotable connection; and,  
 a locking tab adjacent said narrow portion of said first plate.

9. The hitch ball locking plate of claim 8, further comprising a nut and a bolt for pivotably attaching said locking bar to said first plate.

10. The hitch ball locking plate of claim 8, further comprising a second plate integral with said first plate, said second plate centrally aligned on and extending normally across said first plates.

11. The hitch ball locking plate of claim 8, wherein a second plate has at least one locking aperture.

12. The hitch ball locking plate of claim 8, wherein a second plate has a substantially semi-circular removed portion.

13. The hitch ball locking plate of claim 12, wherein said substantially semi-circular removed portion is extending over said narrow portion.

14. The hitch ball locking plate of claim 8, further comprising a plurality of lockdown apertures in a spaced configuration around a peripheral edge of said first plate.

15. A hitch ball locking plate, comprising:  
 a first plate having a first guiding aperture, said first guiding aperture being located on said first plate;  
 a locking bar connected to said first plate; and,  
 a second plate aligned on and normal to said first plate having a removed portion operably communicating with said guiding aperture;  
 wherein said locking bar is pivotably attached to said first plate.

16. The hitch ball locking plate of claim 15, further comprising a locking tab adjacent a narrow portion of said guiding aperture.

17. The hitch ball locking plate of claim 16, said locking tab and said locking bar each having a beveled edge for positioning adjacent a ball hitch.

18. The hitch ball locking plate of claim 15, wherein said first guiding aperture has a wide portion and a narrow portion.

19. The hitch ball locking plate of claim 15, wherein said second plate has at least one aperture.

20. The hitch ball locking plate of claim 15, further comprising a plurality of lockdown apertures in a spaced configuration around a peripheral edge of said first plate.

21. A hitch ball locking plate, comprising:

a first plate having a first aperture positioned there-through;

a locking tab adjacent a narrow portion of said first aperture;

a locking bar attached to said first plate;

a second plate having a removed portion aligned with said first aperture, said second plate extending across said first plate;

said second plate having at least one aperture for securing equipment thereto; and,

a ball hitch, having a head positioned within said removed portion of said second plate and a shaft extending through said guiding aperture.

22. The hitch ball locking plate of claim 21, wherein said locking bar and said locking tab each have an opposed beveled edge.

23. The hitch ball locking plate of claim 21, wherein said locking bar and said first plate each have an aligned locking bar aperture.

24. The hitch ball locking plate of claim 21, further comprising a plurality of lockdown apertures in a spaced configuration around a peripheral edge of said first plate.

25. The hitch ball locking plate of claim 21, wherein said locking bar is pivotably attached to said first plate by a bolt and a nut, said nut being welded to said bolt.

26. A hitch ball locking plate, comprising:  
 a first plate having a positioning aperture centrally located on said first plate;

said positioning aperture having a wide portion and a narrow portion;

a locking tab adjacent said narrow portion of said first plate;

a locking bar pivotably attached to said first plate and having a first locking aperture;

said locking tab and said locking bar having opposed beveled edges;

a second plate integral with and normal to said first plate having a removed portion operably communicating with said positioning aperture;

said the second plate having at least one aperture for securing equipment thereto;

said first plate having a plurality lockdown apertures; and,  
 a ball hitch, having a head positioned within said removed portion of said second plate and a shaft extending through said guiding aperture.

27. The hitch ball locking plate of claim 26 further comprising a bolt and a nut for pivotably attaching said first plate and said locking bar.

28. The hitch ball locking plate of claim 27 further comprising a lock placed through said first locking aperture.

\* \* \* \* \*