



US006523090B2

(12) **United States Patent**  
**Tremblay**

(10) **Patent No.:** **US 6,523,090 B2**  
(45) **Date of Patent:** **\*Feb. 18, 2003**

(54) **SHARED INSTRUCTION CACHE FOR MULTIPLE PROCESSORS**

5,784,630 A \* 7/1998 Saito et al. .... 712/30  
5,958,038 A \* 9/1999 Agrawal et al. .... 712/36

(75) Inventor: **Marc Tremblay**, Menlo Park, CA (US)

**FOREIGN PATENT DOCUMENTS**

(73) Assignee: **Sun Microsystems, Inc.**, Santa Clara, CA (US)

EP 0 588 341 A2 \* 3/1994  
EP 0 911 725 AR 4/1999  
EP 0 911 725 A2 \* 4/1999

(\* ) Notice: Subject to any disclaimer, the term of this patent is extended or adjusted under 35 U.S.C. 154(b) by 0 days.

**OTHER PUBLICATIONS**

This patent is subject to a terminal disclaimer.

IBM Technical Disclosure Bulletin, Shared Instruction and/or Data Caches in a Multiprocessing System, vol. 27, No. 12, May 1985, pp. 6845-6846.\*

(21) Appl. No.: **10/100,263**

\* cited by examiner

(22) Filed: **Mar. 18, 2002**

(65) **Prior Publication Data**

US 2002/0174285 A1 Nov. 21, 2002

*Primary Examiner*—David L. Robertson  
(74) *Attorney, Agent, or Firm*—Zagorin, O'Brien & Graham, LLP

**Related U.S. Application Data**

(57) **ABSTRACT**

(63) Continuation of application No. 09/818,295, filed on Mar. 27, 2001, now Pat. No. 6,378,041, which is a continuation of application No. 09/204,793, filed on Dec. 3, 1998, now Pat. No. 6,212,604.

The present invention provides a shared instruction cache for multiple processors. In one embodiment, an apparatus for a microprocessor includes a shared instruction cache for a first processor and a second processor, and a first register index base for the first processor and a second register index base for the second processor. The apparatus also includes a first memory address base for the first processor and a second memory address base for the second processor. This embodiment allows for segmentation of register files and main memory based on which processor is executing a particular instruction (e.g., an instruction that involves a register access and a memory access).

(51) **Int. Cl.**<sup>7</sup> ..... **G06F 13/00**

(52) **U.S. Cl.** ..... **711/125; 711/3; 711/123; 711/120**

(58) **Field of Search** ..... **711/119, 120, 711/123, 125, 3**

(56) **References Cited**

**U.S. PATENT DOCUMENTS**

5,692,207 A \* 11/1997 Ho-Lung et al. .... 712/36

**19 Claims, 5 Drawing Sheets**

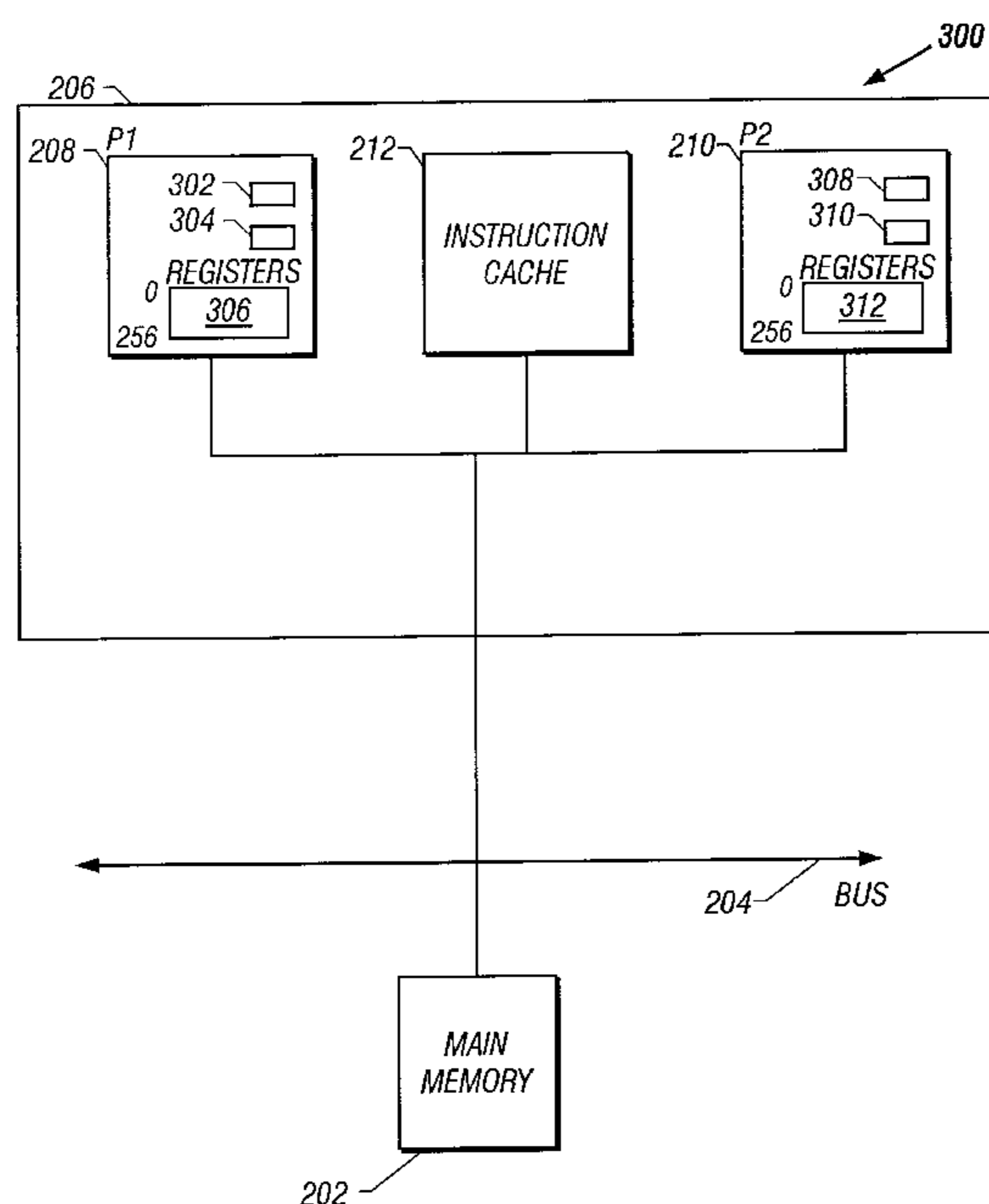

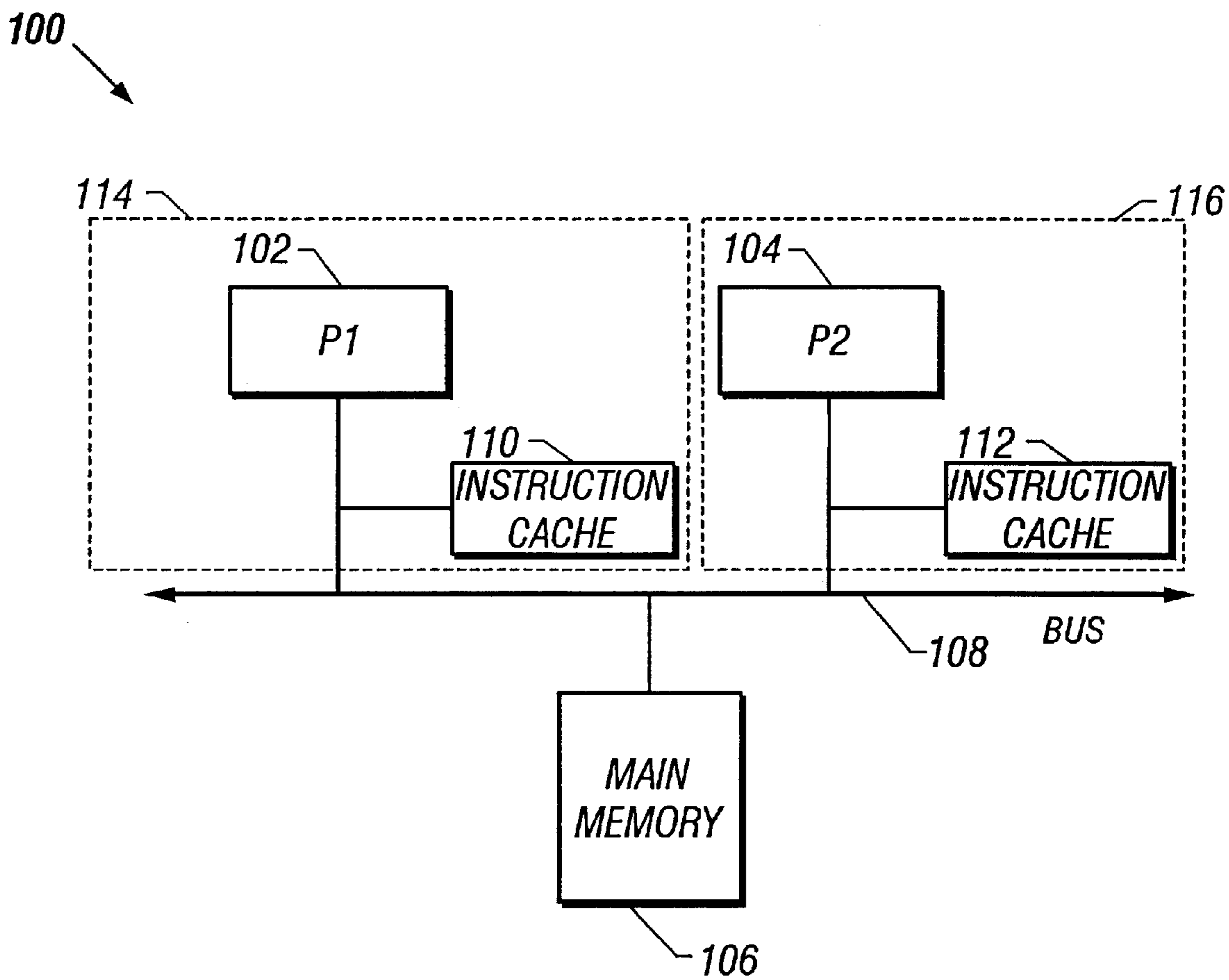

**FIG. 1**  
**(Prior Art)**

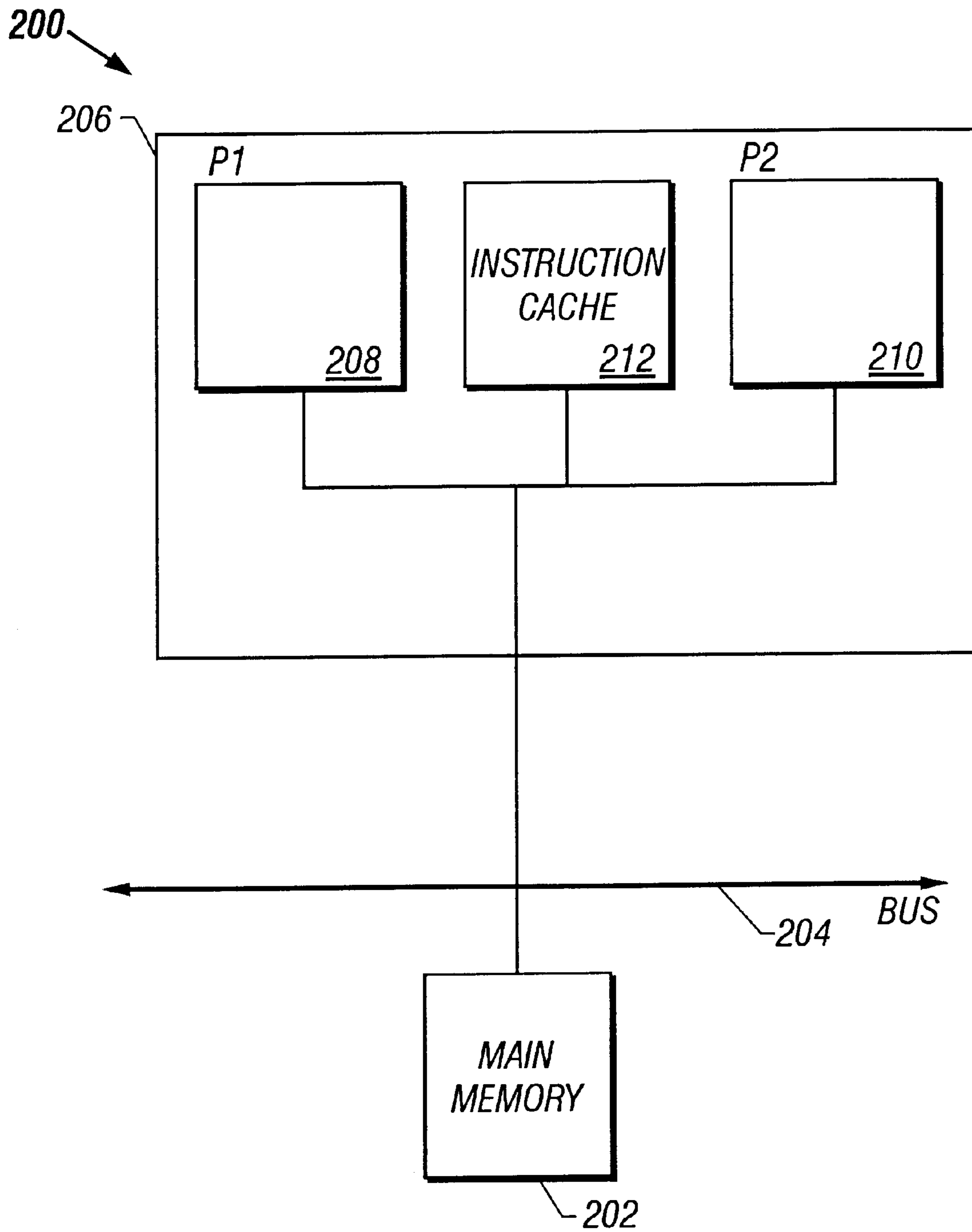

FIG. 2

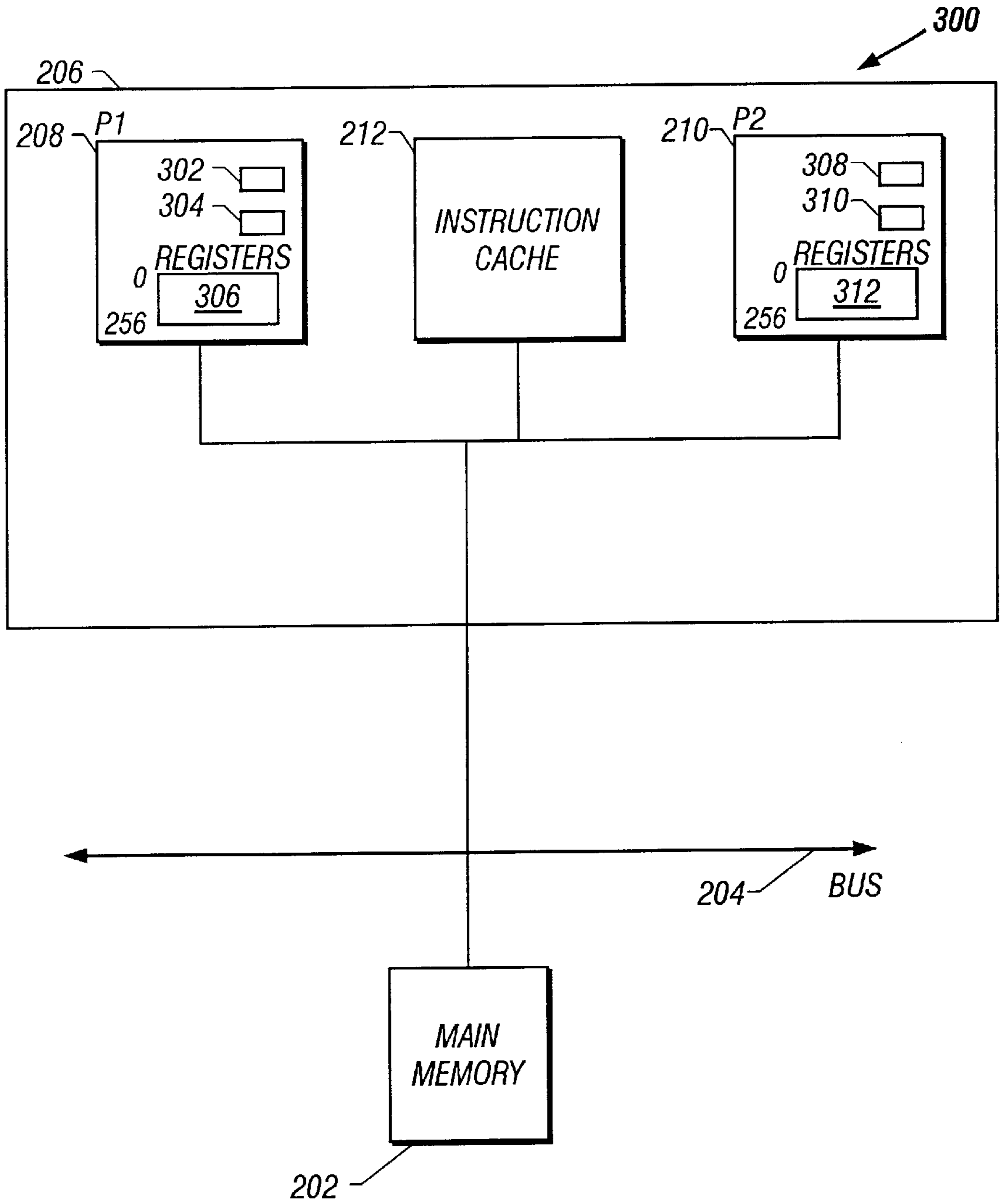

FIG. 3

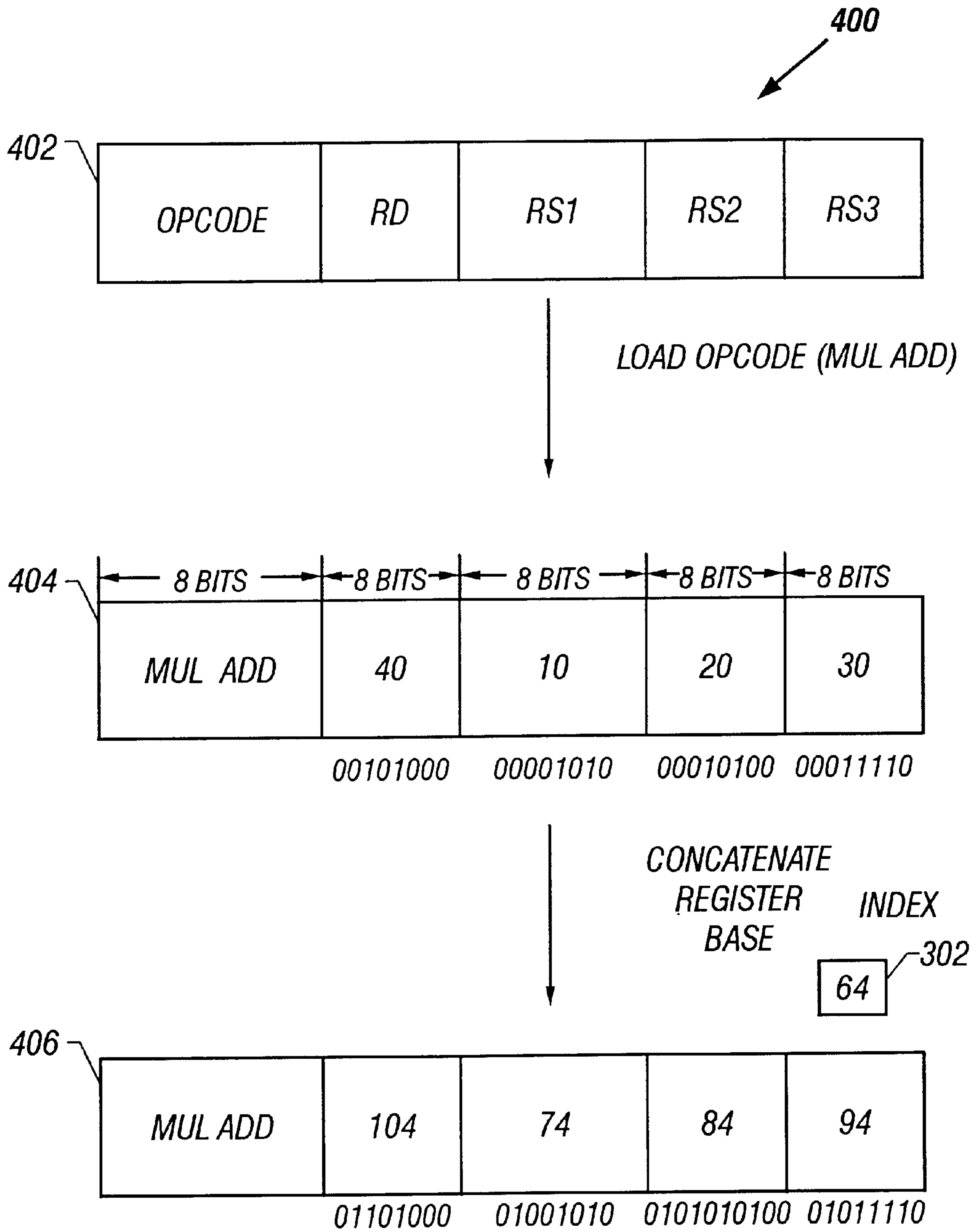

FIG. 4

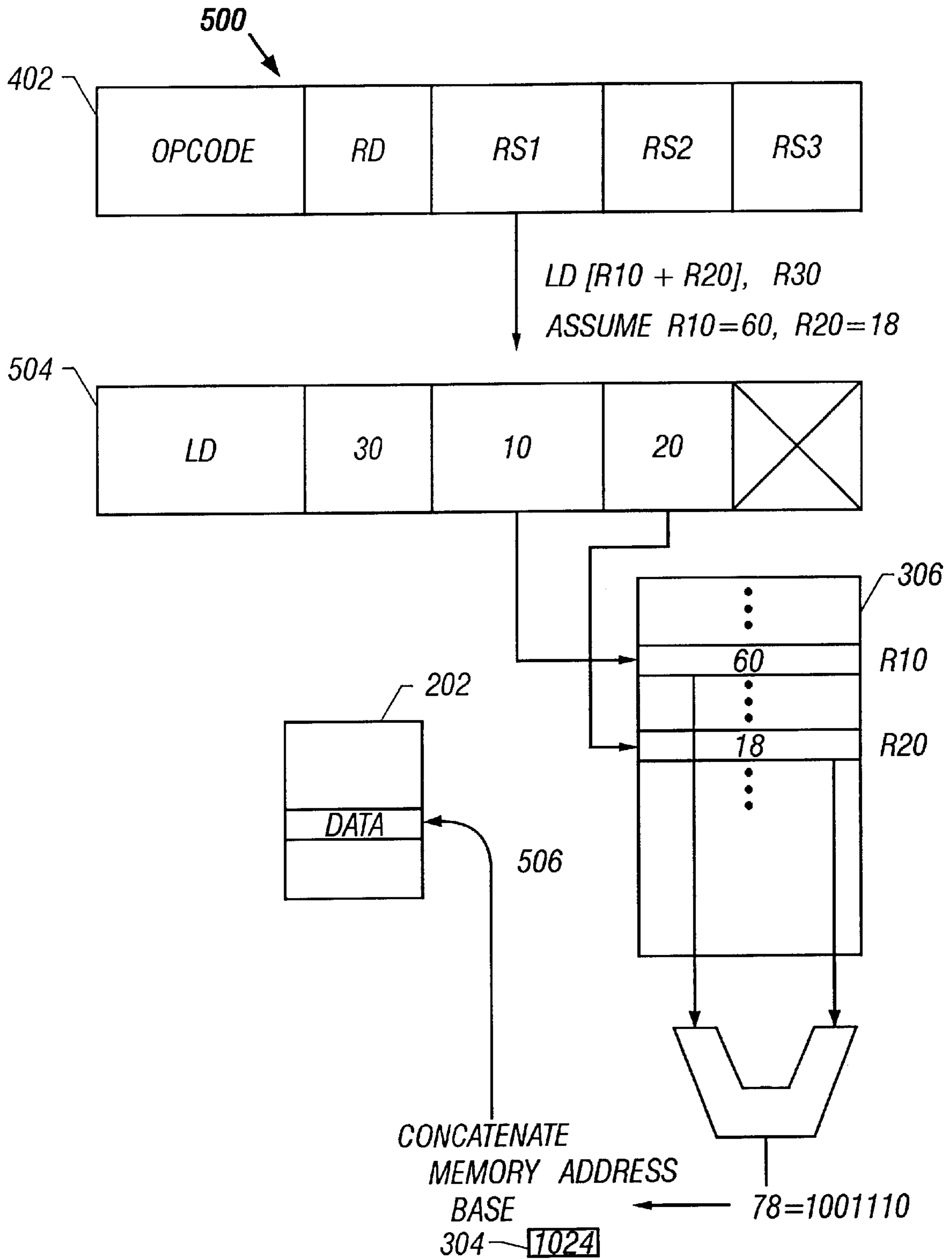

FIG. 5



## SHARED INSTRUCTION CACHE FOR MULTIPLE PROCESSORS

### CROSS-REFERENCE TO RELATED APPLICATIONS

This application is a con of U.S. patent application Ser. No. 09/818,295, filed on Mar. 27, 2001, entitled "Shared Instruction Cache For Multiple Processors" and naming Marc Tremblay as the inventor, issued as U.S. Pat. No. 6,378,041 B2 on Apr. 23, 2002, and which is incorporated herein by reference in its entirety; which is a con of

U.S. patent application Ser. No. 09/204,793, filed on Dec. 3, 1998, entitled "Shared Instruction Cache For Multiple Processors" and naming Marc Tremblay as the inventor, issued as U.S. Pat. No. 6,212,604 B1 on Apr. 3, 2001, and which is incorporated herein by reference in its entirety.

This application relates to application U.S. Ser. No. 09/204,480, filed on Dec. 3, 1998, entitled "A Multiple-Thread Processor For Threaded Software Applications" and naming Marc Tremblay and William Joy as inventors, the application being incorporated herein by reference in its entirety.

This application relates to U.S. Pat. No. 6,321,325, which issued on Nov. 20, 2001 and is being incorporated herein by reference in its entirety.

This application relates to U.S. Pat. No. 6,249,861, which issued on Jun. 19, 2001 and is being incorporated herein by reference in its entirety.

This application relates to U.S. Pat. No. 6,314,509, which issued on Nov. 6, 2001 and is being incorporated herein by reference in its entirety.

### FIELD OF THE INVENTION

The present invention relates generally to microprocessors and, more particularly, to a shared instruction cache for multiple processors.

### BACKGROUND OF THE INVENTION

A microprocessor typically includes a cache memory for storing copies of recently accessed information. The cache memory is generally smaller but faster than main memory (e.g., disk). In particular, a microprocessor typically includes an instruction cache for storing recently accessed (i.e., recently used) instructions. The instruction cache is generally located on the same integrated circuit chip (or die) as the core logic of the microprocessor.

FIG. 1 is a block diagram of a prior art instruction cache subsystem of a multi-processor system 100. In particular, multi-processor system 100 includes two processors, a P1 processor 102 and a P2 processor 104. P1 processor 102 and P2 processor 104 each access a main memory 106 via a bus 108. P1 processor 102 caches recently used instructions in an instruction cache 110. P2 processor 104 caches recently used instructions in an instruction cache 112. P1 processor 102 and instruction cache 110 reside on die (chip) 114. P2 processor 104 and instruction cache 112 reside on die 116. Accordingly, prior art system 100 represents an SMP (Symmetric Multi-Processing) system that shares memory, main memory 106. Further, instruction cache 110 and instruction cache 112 typically each include two ports, a port for connecting to P1 processor 102 and P2 processor 104, respectively, and a port for connecting to main memory 106. The ports can be physical ports or logical ports.

### SUMMARY OF THE INVENTION

The present invention provides a shared instruction cache for multiple processors. For example, the present invention

provides a cost-effective and high performance instruction cache subsystem in a microprocessor that includes multiple processors (i.e., CPUs (Central Processing Units)).

In one embodiment, an apparatus for a microprocessor includes an instruction cache that is shared by a first processor and a second processor, a first register index base for the first processor, and a first memory address base for the first processor. The apparatus also includes a second register index base for the second processor, and a second memory address base for the second processor. On each processor, a register access is offset using the register index base (e.g., a register address specifier is concatenated with the register index base). Similarly, on each processor, a memory access is offset using the memory address base (e.g., a memory address specifier is concatenated with the memory address base). This embodiment provides a shared instruction cache for multiple processors that provides a hardware implemented segmentation of register files and main memory based on which processor is executing a particular instruction (e.g., an instruction that involves a register access or a memory access). For example, this embodiment allows a thread of a multi-threaded computer program that is executed by the first processor and the same thread that is executed by the second processor to generate register files that can later be combined, because the register index base can be set such that the execution of the same thread on the first processor and the second processor do not overlap in their register address specifiers' usage of registers. Similarly, the same thread can be executed on the first processor and on the second processor and by setting different values in the memory address base, the data written into the main memory can be insured to not overlap such that the results of the execution of the same thread on the first processor and the second processor can subsequently be compared or combined.

Other aspects and advantages of the present invention will become apparent from the following detailed description and accompanying drawings.

### BRIEF DESCRIPTION OF THE DRAWINGS

FIG. 1 is a block diagram of a prior art instruction cache subsystem of a multi-processor system.

FIG. 2 is a block diagram of a shared instruction cache for multiple processors in accordance with one embodiment of the present invention.

FIG. 3 is a block diagram of the shared instruction cache for the P1 processor and the P2 processor of FIG. 2 shown in greater detail in accordance with one embodiment of the present invention.

FIG. 4 is a functional diagram of an offset operation using a register index base in accordance with one embodiment of the present invention.

FIG. 5 is a functional diagram of an offset operation using a memory address base in accordance with one embodiment of the present invention.

### DETAILED DESCRIPTION OF THE INVENTION

The present invention provides a shared instruction cache for multiple processors (i.e., CPUs (Central Processing Units)) (e.g., two CPUs or four CPUs). For example, a multi-processor microprocessor that desires a cost-effective and efficient implementation of an instruction cache subsystem would significantly benefit from the present invention.



Referring to prior art FIG. 1, instruction cache, **110** and instruction cache **112** can simultaneously be storing the same instruction(s). Thus, the prior art system **100** uses valuable instruction cache storage by duplicating storage of the same instruction(s). In particular, the same instruction(s) may be stored in three different locations, main memory **106**, instruction cache **110**, and instruction cache **112**.

Accordingly, FIG. 2 is a block diagram showing a multiple processor system having a shared instruction cache in accordance with one embodiment of the present invention. In particular, a system **200** includes a main memory **202**, a bus **204** coupled to main memory **202**, and an integrated circuit **206** coupled to bus **204**. On integrated circuit **206** resides a P1 processor **208**, a P2 processor **210**, and a shared instruction cache **212**. Thus, system **200** is a multiple processor system in which P1 processor **208** and P2 processor **210** are integrated on the same die (chip) and share the same instruction cache, instruction cache **212**. In a preferred embodiment, instruction cache **212** is a 16-kilobyte cache (e.g., a conventional 16-kilobyte dual-ported cache that uses a well-known (standard) cache architecture of two-way set associative, 32-byte lines to minimize cost and timing risk). Shared instruction cache **212** may be included within the integrated circuit die or external to the integrated circuit die on which one or more of the processors reside.

By sharing instruction cache **212**, system **200** efficiently uses instruction cache storage space by avoiding duplicating storage of instruction(s) in instruction cache **212** by P1 processor **208** and P2 processor **210**. Shared instruction cache **212** advantageously eliminates cache coherency protocols, reduces total area of cache memory, and allows for the automatic sharing of code. For example, a particular instruction (e.g., opcode and register address specifier(s) or memory address specifier(s)) that is cached by both P1 processor **208** and P2 processor **210** uses one storage location of instruction cache **212** (e.g., a cache line in instruction cache **212**). For example, if P1 processor **208** executes a particular library call, and subsequently P2 processor **210** issues the same library call, then if the library call executed by P1 processor **208** is cached in instruction cache **212**, P2 processor **210** can access the cached library call in instruction cache **212** rather than having to access main memory **202** via bus **204** thereby increasing performance. Accordingly, system **200** advantageously allows for the sharing of cached instructions in instruction cache **212** for P1 processor **208** and P2 processor **210**. Additionally, because in many instances an operating system maps different library calls to different pages in memory, the use of a shared instruction cache which allows use of the same library call can save substantially half the cache space.

A challenge with sharing instructions among multiple processors is that the instruction may specify particular registers or particular memory address locations, while the multiple processors may use different registers or different memory address locations. For example, it may be advantageous for a particular thread of execution of a multi-threaded computer program to be executed on a first processor, and the same thread to be executed on a second processor, and then the register files of the threads of execution on the first processor and the second processor to subsequently be combined. However, if the thread of execution on the first processor and the thread of execution on the second processor specify the same registers, then these register files overlap and, thus, generally cannot be combined.

Accordingly, FIG. 3 is a block diagram of shared instruction cache **212** for P1 processor **208** and P2 processor **210**

shown in greater detail in accordance with one embodiment of the present invention. A system **300** includes P1 processor **208**, which includes a register index base **302**, a memory address base **304**, and registers (register file) **306**, and P2 processor **210**, which includes a register index base **308**, a memory address base **310**, and registers (register file) **312**. Registers **306** include **256** registers, and registers **312** include **256** registers.

System **300** allows for the same instruction(s) to be stored in instruction cache **212** for P1 processor **208** and P2 processor **210**, but also allows for the same instruction(s) stored in instruction cache **212** to access different registers or a different segment of the register files, registers **306** and registers **312**, of P1 processor **208** and P2 processor **210** when executed on P1 processor **208** and P2 processor **210**, respectively. System **300** also allows for the same instruction (s) stored in instruction cache **212** and executed on P1 processor **208** and P2 processor **210** to access different segments of main memory **202**. In particular, system **300** includes register index base **302** and register index base **308** that are used to offset register address specifiers of instructions executed on P1 processor **208** and P2 processor **210**, respectively. System **300** includes memory address base **304** and memory address base **310** that are used to offset memory address specifiers of instructions executed on P1 processor **208** and P2 processor **210**, respectively. By setting (e.g., loading) the register index base registers and the memory address base registers of P1 processor **208** and P2 processor **210** to different values, system **300** allows for a hardware implemented segmentation of the register files and the main memory of system **300**.

For example, register index base **302** of P1 processor **208** can be set to 0, which results in a one-to-one correlation between the registers specified in an instruction and the registers used by P1 processor **208** during execution of the instruction. However, register index base **308** of P2 processor **210** can be set to **128**. As a result, register address specifiers of the instruction executed on P2 processor **210** are offset using the value of register index base **308** and, in particular, are offset by either adding **128** to the register address specifier value or concatenating **128** to the register address specifier value of the instruction. For example, offsetting register address specifiers of instructions executed on P2 processor **210** by **128** can be implemented by setting the upper bit of an 8-bit address for the register address specifier to 1. If software compilers for system **300** and software written for system **300** only include functions that specify up to **128** registers, then register address specifiers would not need to specify a register address with the upper bit of an 8-bit address set to 1, because it only needs to specify (address) registers in the range of 0 to 127. Thus, adding **128** to a register address specifier in this case is nearly free from a performance standpoint, because the register index base stored in register index base **308** can simply be concatenated with the register address specifier. Accordingly, system **300** effectively segments the register files of P1 processor **208** and P2 processor **210** into two segments by setting register index base **302** to 0 (i.e., registers **0** to **127**) and register index base **308** to 128 (i.e., registers **128** to **255**).

As another example, some microprocessors include processors that only use 32 registers (e.g., Sun Microsystems' well-known SPARC architecture uses 32 registers). Thus, register index base **302** and register index base **308** can be set to specify eight different segments by using the upper three bits of an 8-bit address for a register address specifier to define the eight different segments. For example, the



upper three bits can be set to 000, for a segment including registers **0** to **31**, 001 for a segment including registers **32** to **63**, 010 for a segment including registers **64** to **95**, . . . , and 111 for a segment including registers **223** to **255**. Thus, eight segments of registers or octants can be defined in this example.

System **300** also allows for P1 processor **208** and P2 processor **210** executing the same instruction(s) cached in instruction cache **212** to access different locations or segments in main memory **202**. In particular, system **300** provides an efficient hardware implemented approach, unlike a software implemented approach, which requires significant additional set-up code. For example, memory address base **304** of P1 processor **208** can be set to 0. Thus, memory address specifiers of an instruction executed on P1 processor **208** results in a one-to-one correlation between the memory locations accessed in main memory **202** and the memory address specifiers of the executed instruction. However, memory address base **310** of P2 processor **210** can be set to 10,000 (base **10**, that is, a decimal value). Thus, memory address specifiers of the instruction executed on P2 processor **210** are offset by the value 10,000. Hence, main memory **202** is segmented between P1 processor **208** and P2 processor **210** (assuming no memory address specifiers exceed 9,999). The offset operation for memory address specifiers can be implemented as an add or a concatenation operation as similarly described above with respect to the offset operation for register address specifiers.

In one embodiment, memory address base **304** and memory address base **310** each include a load address base for load operations and a store address base for store operations. For example, it may be desirable for P1 processor **208** and P2 processor **210** to share input data, which is stored in main memory **202** or a data cache (not shown). Thus, load address bases of P1 processor **208** and P2 processor **210** can be set to the same value. For example, P1 processor **208** and P2 processor **210** can process the same image stored as data in data memory (e.g., main memory **202** or a data cache). However, P1 processor **208** and P2 processor **210** can process the stored data image differently. For example, P1 processor **208** can change the colors of the data image from green to red, while P2 processor **210** changes the colors of the data image from green to blue. It may be desirable to then compare the differently processed images. Thus, the store address bases of P1 processor **208** and P2 processor **210** can be set to different values such that the differently processed data images are stored in different storage locations in data memory.

For example, instructions for library calls can be shared in instruction cache **212** and executed on P1 processor **208** and P2 processor **210** using different segments of the register files of P1 processor **208** and P2 processor **210**, respectively. Thus, only one library call routine can be written, and system **300** advantageously allows for the segmentation of the register files, such as registers **0** to **127** for P1 processor **208** and registers **128** to **255** for P2 processor **210**. Otherwise, a second library routine call would need to be written to achieve the same functionality, a first library routine call specifying registers **0** to **127**, and a second library routine call specifying registers **128** to **255**. Alternatively, the code can be written with support for sharing, which includes indirect addressing, jump tables, and other methods, which increase the footprint of the routine that slows down execution. Also, such an implementation would require twice the space in main memory **202** for storing the second library routine call and would effectively reduce the instruction cache **212** hit rate and use instruction

cache **212** less efficiently. Moreover, because the first and second library routine call in such an implementation would reside in two different storage locations in main memory **202**, there is a possibility that the stored memory routine calls can be stored at locations that are a multiple of 16 kilobytes apart. If instruction cache **212** is a 16-kilobyte instruction cache, then these library routine calls generally could not both simultaneously reside in instruction cache **212** and, thus, would require main memory access, which is expensive from a performance standpoint.

System **300** is flexible. If segmentation of the register files or main memory is not desired, then the register address bases and the memory address bases of P1 processor **208** and P2 processor **210** can simply be set to the same values (e.g., 0).

For example, a computer program can include multiple threads of execution (i.e., a multi-threaded computer program). In a multi-threaded computer program, a compiler that compiles the multi-threaded computer program can generate "set base register" instructions for setting the register index bases (e.g., loading a value into the register index bases) and instructions for setting the memory address bases. The setting of the registers index base registers and the memory address base registers can be performed at the beginning of each thread of the compiled multi-threaded computer program. Thus, as the threads are allocated to different processors (CPUs), the base register values are set accordingly. Thus, as part of a thread safe compilation process, the threads of the multi-threaded computer program can be allocated different segments of the register file or different segments of the main memory or both. For example, thread **1** of a multi-threaded computer program can operate on registers **0** to **31**, thread **2** can operate on registers **32** to **63**, . . . , and thread **8** can operate on registers **228** to **255**. Similarly, different threads can be allocated different segments of main memory so that they do not overwrite the same main memory storage locations. Moreover, unlike a software implemented approach, system **300** allows for this implementation without requiring significant additional set-up code. In this example, an operating system can send thread **1** to P1 processor **208**, send thread **2** to P2 processor **210**, and send thread **3** to the next available processor. But by compiling thread **3** such that it has a different register index base and a different memory address base, thread **3**, regardless of which processor it ends up executing on, can be using a different segment of the register file of the processor and a different segment of main memory **202**.

The instructions stored in instruction cache **212**, which is shared between P1 processor **208** and P2 processor **210**, are not modified, and in particular, the register address specifiers and the memory address specifiers of the instructions remain the same values. For example, pseudo code of a compiled multi-threaded computer program is listed below.

```
BEGIN THREAD 1
```

```
/*Initialize the base registers*/
```

```
Set register index base
```

```
Set store address base
```

```
Set load address base
```

```
CALL
```

```
F(x)
```

```
F(x,y)
```

```
F(w)
```

```
END THREAD 1/*do not need to reset the base registers,
because the next thread will initialize the base
registers*/
```



As shown in the above pseudo code, at the beginning of a compiled thread **1**, the base registers are set or initialized. Thus, a register index base is set to a particular value, a store address base is set to a particular value, and a load address base is set to a particular value. Thread **1** then executes various instructions such as calls to various functions (e.g., library calls). At the end of thread **1**, the base registers do not need to be reset, because the next thread will appropriately initialize the base registers.

FIG. 4 is a functional diagram **400** of an offset operation using a register index base in accordance with one embodiment of the present invention. Block **402** is a storage location for an operation code (opcode) that includes a register destination (Rd) and up to three register address specifiers (RS1, RS2, and RS3). Block **404** is a storage location that is loaded with a multiply add opcode, MUL ADD. Block **404** includes the MUL ADD operation, which requires 8 bits, an 8-bit Rd that is set to the decimal value of 40, an 8-bit RS1 that is set to the decimal value of 10, an 8-bit RS2 that is set to the decimal value of 20, and an 8-bit RS3 that is set to the decimal value of 30. The MUL ADD operation multiplies RS1 and RS2, then adds RS3 to the product, and stores the result in RS4. The binary equivalents to the decimal values stored in the register address specifiers of block **404** are shown below each sub-block. The register index base stored in register index base register **302** of P1 processor **208** is concatenated to the register address specifiers of block **404**. The result of the concatenation of the register index base with the register address specifiers of block **404**, assuming the register index base is set to the decimal value of 64, is shown in block **406**. In particular, block **406** is a storage location that includes the MUL ADD opcode, RS1 now set to 104, RS2 now set to 74, RS3 now set to 84, and RS4 now set to 94. The binary equivalents of the decimal values of the register address specifiers of block **406** are shown below each sub-block.

FIG. 5 is a functional diagram **500** of an offset operation using a memory address base in accordance with one embodiment of the present invention. Functional diagram **500** includes block **402** that is a storage location for an opcode that includes up to four register address specifiers. Block **504** is a storage location that is loaded with the "1d[R10+R20], R30" operation. As shown in FIG. 5, R10 and R20 are storage locations in register file **306**. The storage location R10 stores the decimal value 60, and the storage location R20 stores the decimal value 13. The load operation results in the addition of the decimal value 60 and the decimal value 13, which equals the decimal value 73 (i.e., a binary value 1001110). The memory address base, which is stored in memory address base register **304**, is then concatenated with the binary value equal to 73 to provide a new memory address pointer **506** that points to a storage location of main memory **202**. If the memory address base is set to 1024 in decimal (base 10) or 1000000000 in binary, then pointer **506** points to memory address location 1102 in decimal or 1001001110 in binary in main memory **202**. This concatenation operation can be implemented without requiring significant extra gates in the critical path. If a first thread, which sets register address bases and memory address bases to different values, desires to know the results of the execution of a second thread, then the first thread can set the register address bases and the memory address bases to the same values as the second thread.

Although particular embodiments of the present invention have been shown and described, it will be obvious to those skilled in the art that changes and modifications can be made without departing from the present invention in its broader

aspects, and therefore, the appended claims are to encompass within their scope all such changes and modifications that fall within the true scope of the present invention.

What is claimed is:

1. A method for operating a multiple processor system, the multiple processor system including a first processor, a second processor and a shared instruction cache, the method comprising:

storing an instruction in the instruction cache, the instruction cache being shared by the first processor and the second processor;

storing a first register index base for the first processor;

storing a second register index base for the second processor; and,

using the first register index base and the second register index base to enable the instruction to be executed on both the first processor and the second processor.

2. The method of claim 1 further comprising:

storing a first memory address base for the first processor and a second memory address base for the second processor.

3. The method of claim 2 further comprising:

executing the instruction stored in the instruction cache on the first processor by offsetting a register address specifier of the instruction using the first register index base; and

executing the instruction stored in the instruction cache on the second processor by offsetting the register address specifier using the second register index base.

4. The method of claim 3 further comprising:

segmenting a first register file of the first processor and a second register file of the second processor using the first register index base and the second register index base, respectively, so that the first register file and the second register file can be combined after executing a thread of a multi-threaded computer program on the first processor and the second processor.

5. The method of claim 2 further comprising:

executing the instruction stored in the instruction cache on the first processor by offsetting a memory address specifier using the first memory address base; and

executing the instruction stored in the instruction cache on the second processor by offsetting the memory address specifier using the second memory address base.

6. The method of claim 5 further comprising:

segmenting a main memory using the first memory address base and the second memory address base so that a thread of a multi-threaded computer program executed by the first processor uses a first segment of the main memory, and the thread of the multi-threaded computer program executed by the second processor uses a second segment of the main memory, wherein the first segment and second segment do not overlap.

7. The method of claim 5 further comprising:

storing a first load address base for the first processor and storing a second load address base for the second processor; and

storing a first store address base for the first processor and storing a second store address base for the second processor.

8. The method of claim 5 wherein the offsetting is performed using a concatenation operation.



9

- 9.** A system comprising:  
 first and second processing units;  
 an instruction cache configured to store an instruction that  
 can be executed by the first processor and by the second  
 processor; 5  
 a first register index base for the first processor stored in  
 a first register; and  
 a second register index base for the second processor  
 stored in a second register.
- 10.** The system of claim **9** further comprising: 10  
 a first memory address base for the first processor stored  
 in the third register; and  
 a second memory address base for the second processor  
 stored in a fourth register.
- 11.** The system of claim **10** wherein the first memory 15  
 address base and the second memory address base each  
 comprise a load address base and a store address base.
- 12.** An apparatus comprising  
 means for storing an instruction in an instruction cache,  
 the instruction cache being shared by a first processor 20  
 and a second processor;  
 means for storing a first register index base for the first  
 processor;  
 means for storing a second register index base for the  
 second processor; and, 25  
 means for using the first register index base and the  
 second register index base to enable the instruction to  
 be executed on both the first processor and the second  
 processor.
- 13.** The apparatus of claim **12** further comprising: 30  
 means for storing a first memory address base for the first  
 processor and a second memory address base for the  
 second processor.
- 14.** The apparatus of claim **13** further comprising: 35  
 means for executing the instruction stored in the instruc-  
 tion cache on the first processor by offsetting a register  
 address specifier of the instruction using the first reg-  
 ister index base; and  
 means for executing the instruction stored in the instruc- 40  
 tion cache on the second processor by offsetting the  
 register address specifier using the second register  
 index base.

10

- 15.** The apparatus of claim **14** further comprising:  
 means for segmenting a first register file of the first  
 processor and a second register file of the second  
 processor using the first register index base and the  
 second register index base, respectively, so that the first  
 register file and the second register file can be com-  
 bined after executing a thread of a multi-threaded  
 computer program on the first processor and the second  
 processor.
- 16.** The apparatus of claim **13** further comprising:  
 means for executing the instruction stored in the instruc-  
 tion cache on the first processor by offsetting a memory  
 address specifier using the first memory address base;  
 and  
 means for executing the instruction stored in the instruc-  
 tion cache on the second processor by offsetting the  
 memory address specifier using the second memory  
 address base.
- 17.** The apparatus of claim **16** further comprising:  
 means for segmenting a main memory using the first  
 memory address base and the second memory address  
 base so that a thread of a multi-threaded computer  
 program executed by the first processor uses a first  
 segment of the main memory, and the thread of the  
 multi-threaded computer program executed by the sec-  
 ond processor uses a second segment of the main  
 memory, wherein the first segment and second segment  
 do not overlap.
- 18.** The apparatus of claim **16** further comprising:  
 means for storing a first load address base for the first  
 processor and storing a second load address base for the  
 second processor; and  
 means for storing a first store address base for the first  
 processor and storing a second store address base for  
 the second processor.
- 19.** The apparatus of claim **16** further comprising:  
 means for performing the offsetting using a concatenation  
 operation.

\* \* \* \* \*