



US006475502B1

(12) **United States Patent**
Lee et al.

(10) **Patent No.:** **US 6,475,502 B1**
(45) **Date of Patent:** ***Nov. 5, 2002**

(54) **KITS CONTAINING CYANOACRYLATE COMPOSITIONS COMPRISING AN ANTIMICROBIAL AGENT**

2,900,305 A 8/1959 Siggia
3,527,224 A 9/1970 Rabinowitz
3,591,676 A 7/1971 Hawkins et al.
3,654,239 A 4/1972 McIntire et al.

(75) Inventors: **Connie C. Lee**, Northborough, MA (US); **Richard J. Greff**, St. Pete Beach, FL (US); **Ian N. Askill**, Colorado Springs, CO (US)

(List continued on next page.)

(73) Assignee: **Flowers Park Ltd.**, Wheshire (GB)

FOREIGN PATENT DOCUMENTS

(*) Notice: Subject to any disclaimer, the term of this patent is extended or adjusted under 35 U.S.C. 154(b) by 0 days.

WO WO 93/25196 12/1993
WO WO 96/23532 8/1996

This patent is subject to a terminal disclaimer.

OTHER PUBLICATIONS

(21) Appl. No.: **09/584,473**

Hagen et al., "A Comparison of Two Skin Preps Used in Cardiac Surgical Procedures," *AORN Journal*, 1995, 62(3):393-402.

(22) Filed: **Jun. 1, 2000**

Osuna, et al., "Comparison of an Antimicrobial Adhesive Drape and Povidone-Iodine Preoperative Skin Preparation in Dogs," *Veterinary Surgery*, 1992, 21(6):458-462.

Related U.S. Application Data

(60) Division of application No. 09/185,227, filed on Nov. 3, 1998, now abandoned, which is a continuation-in-part of application No. 08/962,869, filed on Nov. 3, 1997, now Pat. No. 6,090,397.

Ritter, et al., "Retrospective Evaluation of an Iodophor-Incorporated Antimicrobial Plastic Adhesive Wound Drape," *Clinical Orthopedics and Related Research*, 1988, pp. 307-308.

(51) **Int. Cl.⁷** **A61L 26/00**; A61L 15/00; A61L 15/44; A61L 15/58

Blum, et al., In vitro Determination of the Antimicrobial Properties of Two Cyanoacrylate Preparations, *J. Dent. Res.*, 1975, 54(3):500-503.

(52) **U.S. Cl.** **424/405**; 424/407; 424/400; 424/443; 424/447

Primary Examiner—Thurman K. Page

Assistant Examiner—Rachel M. Bennett

(74) *Attorney, Agent, or Firm*—Burns, Doane, Swecker and Mathis LLP

(58) **Field of Search** 424/405, 407; 606/214; 604/46, 87, 89, 310, 311

(57) **ABSTRACT**

Disclosed are kits of parts comprising a first container comprising a cyanoacrylate composition and a second container comprising a compatible antimicrobial agent and, in particular, a compatible iodine containing antimicrobial agent. Mixture of these compositions provide for in situ formation of an antimicrobial polymeric cyanoacrylate film on mammalian skin.

(56) **References Cited**

U.S. PATENT DOCUMENTS

2,706,701 A 4/1955 Beller et al.
2,784,127 A 3/1957 Joyner et al.
2,826,532 A 3/1958 Hosmer

7 Claims, 7 Drawing Sheets

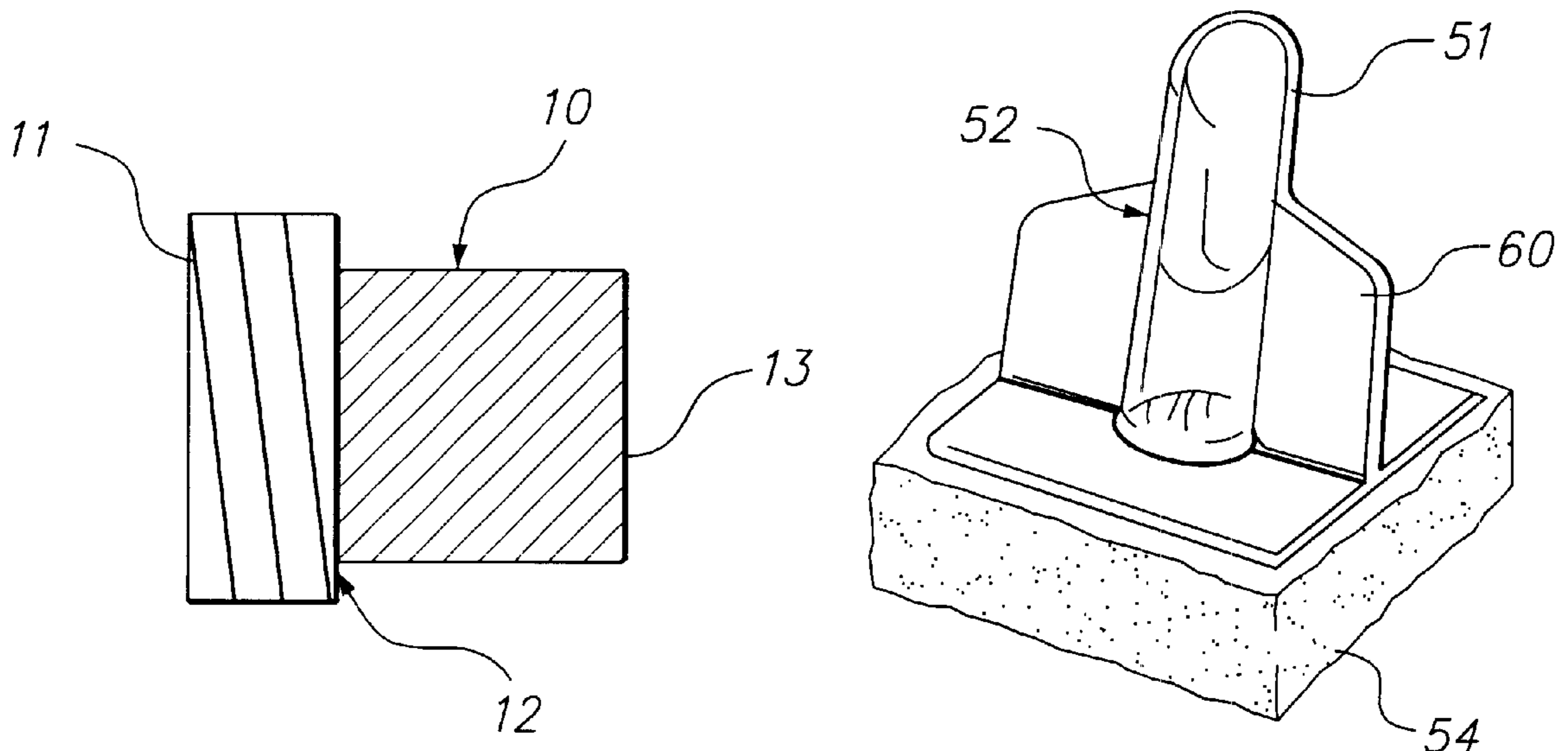

US 6,475,502 B1

Page 2

| U.S. PATENT DOCUMENTS | | |
|-----------------------|---------|---------------------------|
| 3,667,472 A | 6/1972 | Halpern |
| 3,995,641 A | 12/1976 | Kronenthal et al. |
| 4,035,334 A | 7/1977 | Davydov et al. |
| 4,038,345 A | 7/1977 | O'Sullivan et al. |
| 4,183,684 A | 1/1980 | Avery, Jr. |
| 4,374,126 A | 2/1983 | Cardarelli et al. |
| 4,444,933 A | 4/1984 | Columbus et al. |
| 4,542,012 A | 9/1985 | Dell |
| 4,648,532 A * | 3/1987 | Green 222/82 |
| 4,650,826 A | 3/1987 | Waniczek et al. |
| 4,808,184 A | 2/1989 | Tepic |
| 5,051,256 A | 9/1991 | Barnes |
| 5,069,907 A | 12/1991 | Mixon et al. |
| 5,154,320 A | 10/1992 | Bolduc |
| 5,173,291 A | 12/1992 | Brink et al. |
| 5,254,132 A | 10/1993 | Barley et al. |
| 5,259,835 A | 11/1993 | Clark et al. |
| 5,328,687 A | 7/1994 | Leung et al. |
| 5,409,141 A | 4/1995 | Kikuchi et al. |
| 5,466,220 A | 11/1995 | Breneman |
| 5,474,209 A | 12/1995 | Vallet Mas et al. |
| 5,480,935 A * | 1/1996 | Greff et al. 524/776 |
| 5,529,577 A | 6/1996 | Hammerslag |
| 5,547,662 A | 8/1996 | Khan et al. |
| 5,554,365 A | 9/1996 | Byram et al. |
| 5,580,565 A * | 12/1996 | Tighe et al. 424/400 |
| 5,653,769 A | 8/1997 | Barley et al. |
| 5,684,042 A * | 11/1997 | Greff et al. 514/257 |
| 5,730,994 A | 3/1998 | Askill et al. |
| 6,090,397 A * | 7/2000 | Lee et al. 424/405 |

* cited by examiner

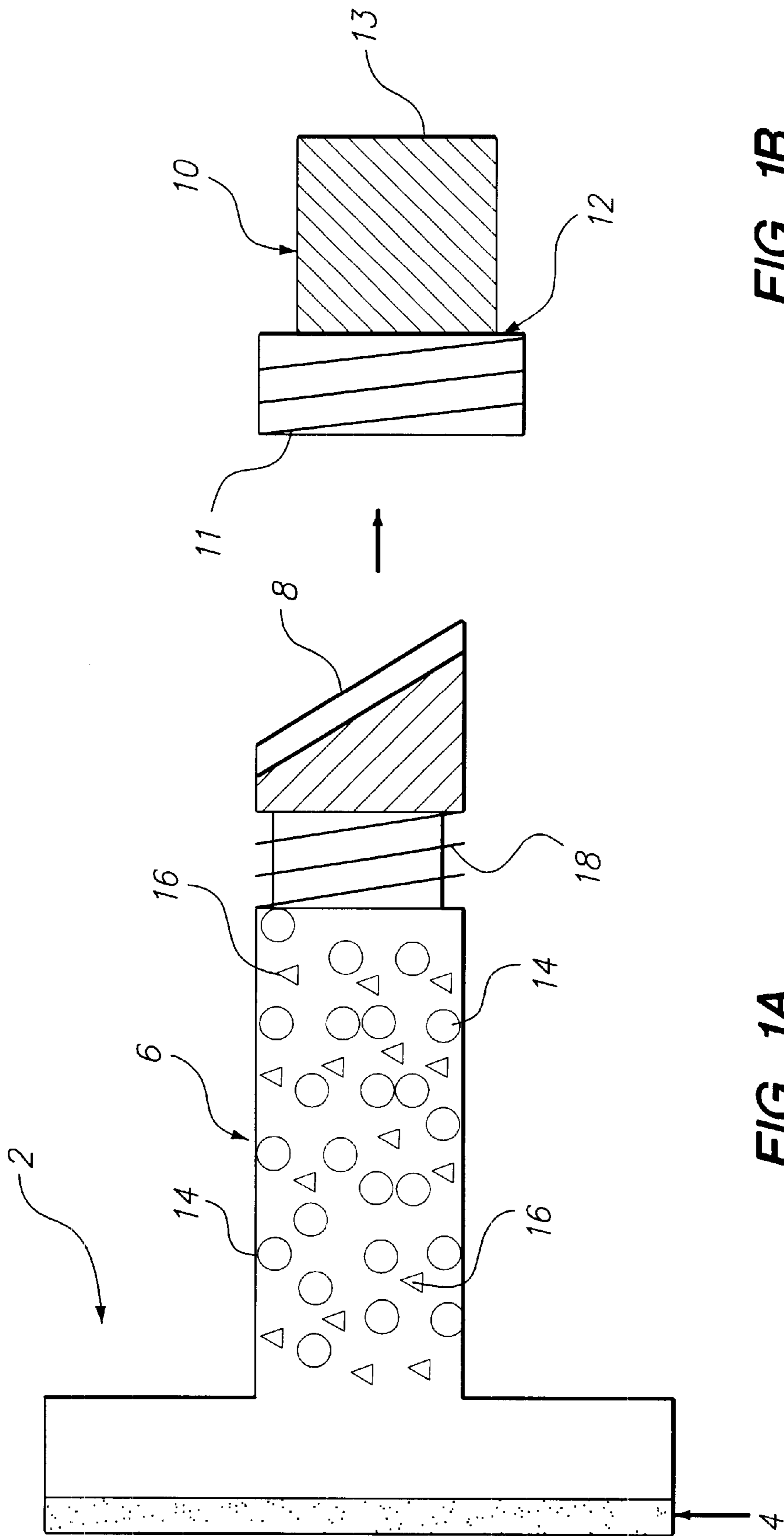

FIG. 1B

FIG. 1A

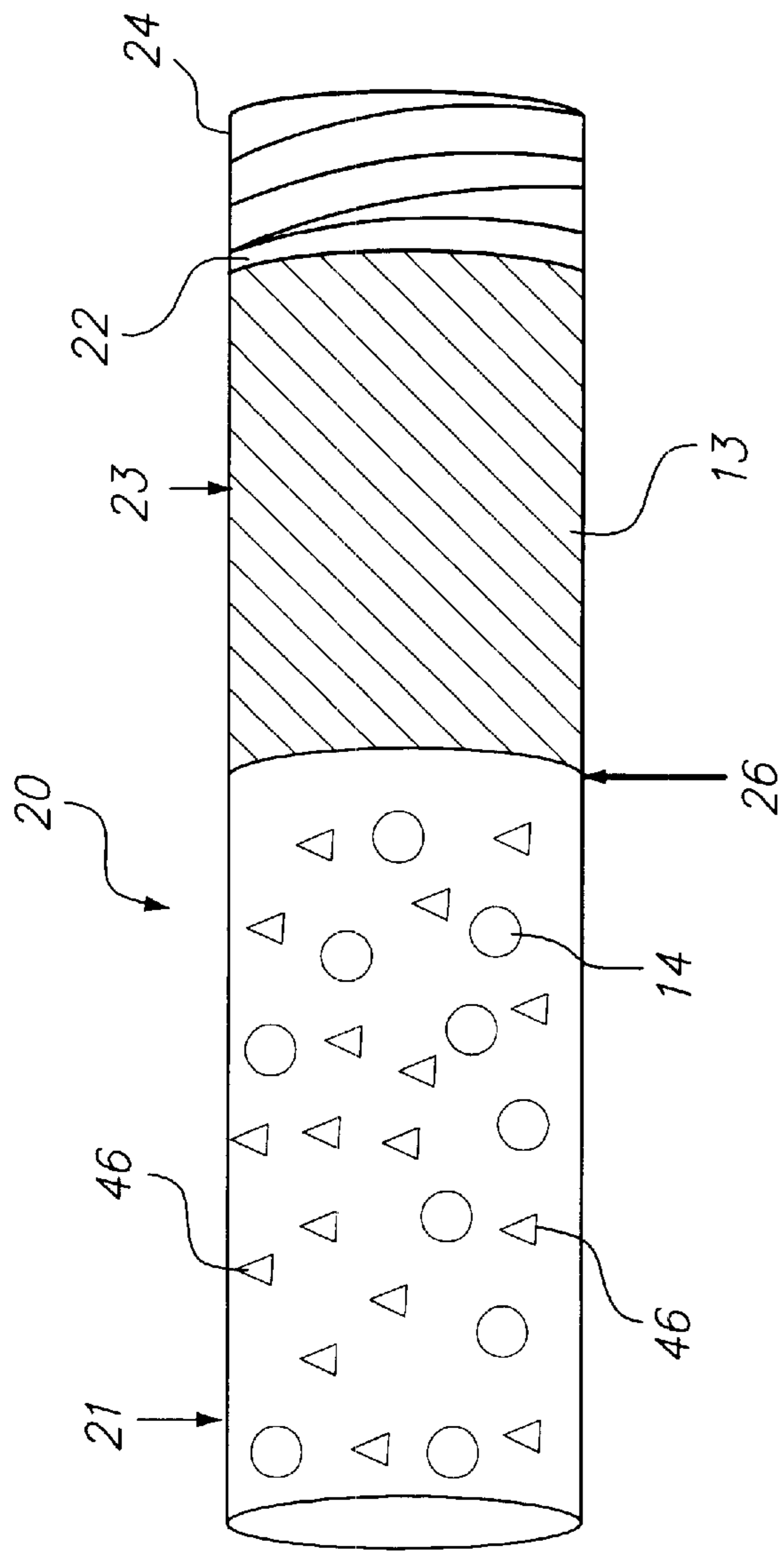

FIG. 2A

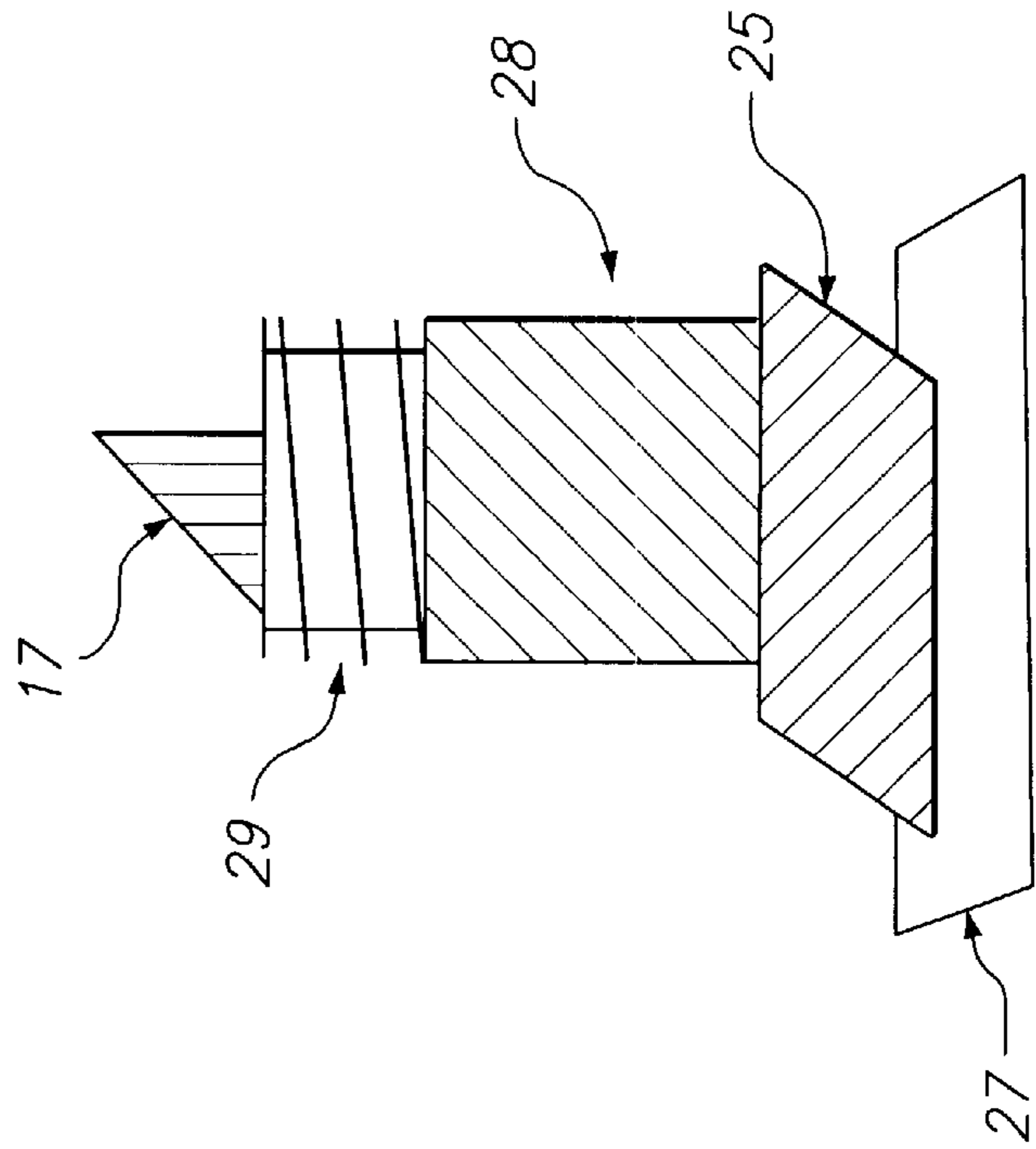

FIG. 2B

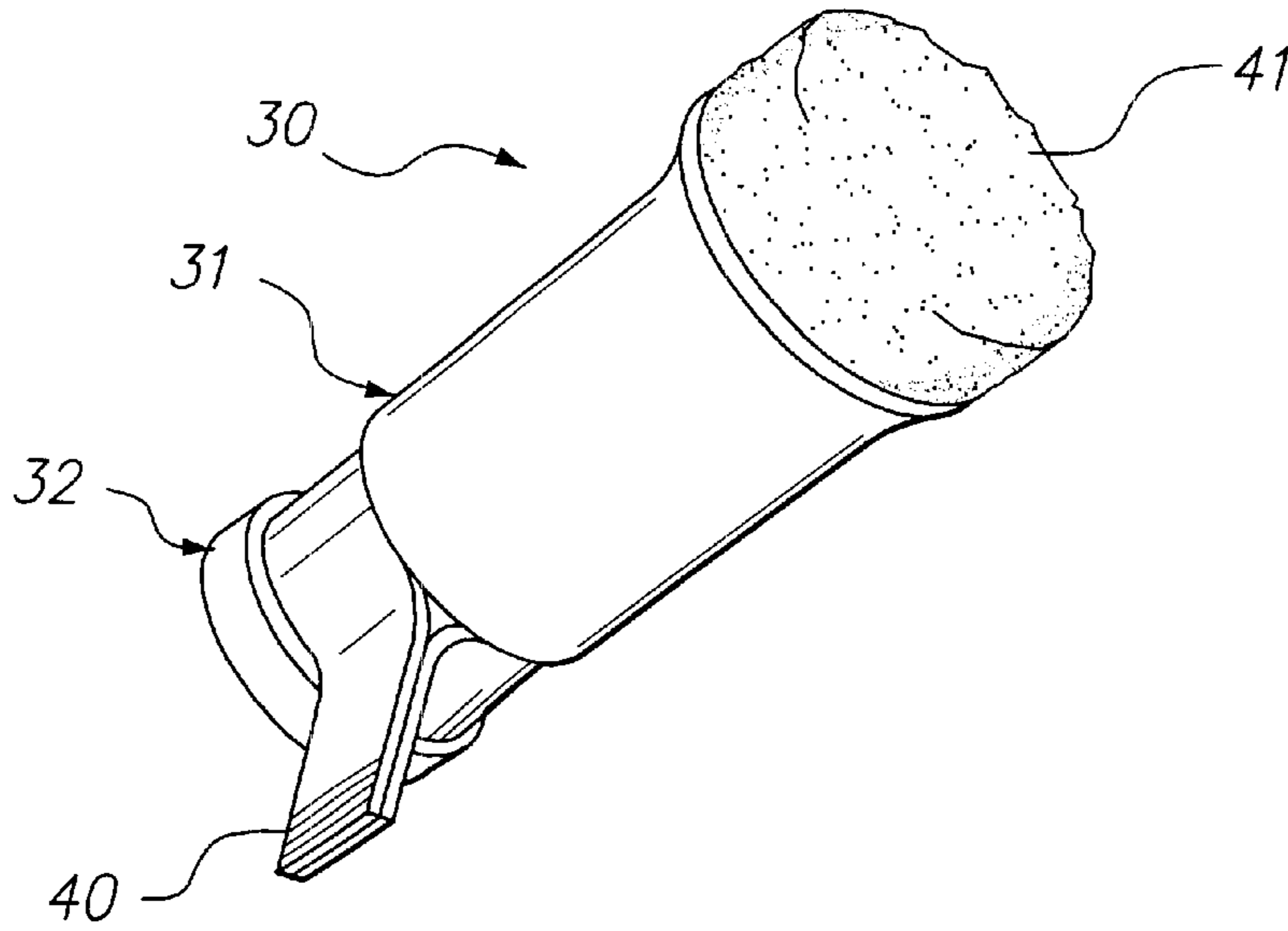

FIG. 3A

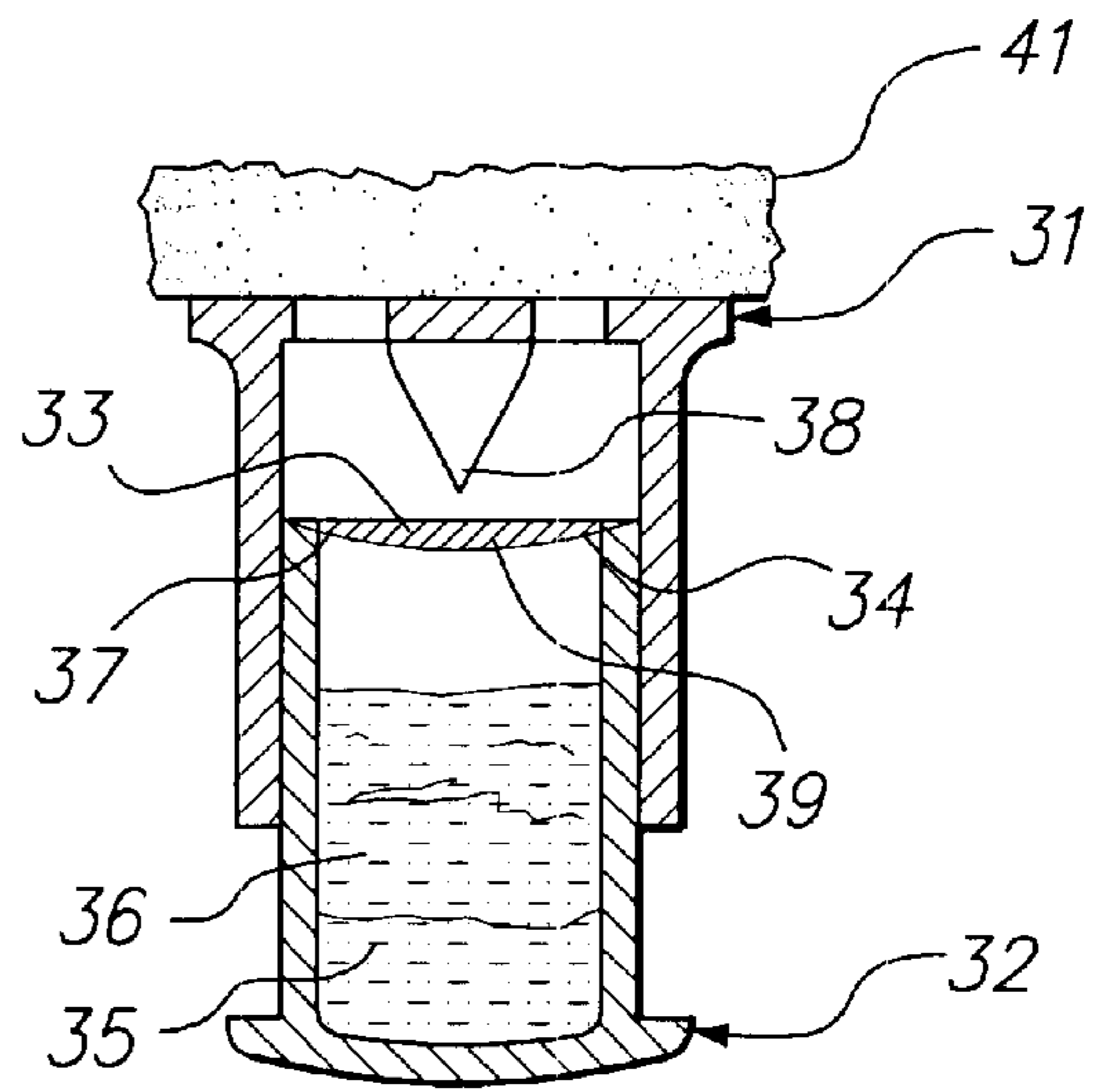

FIG. 3B

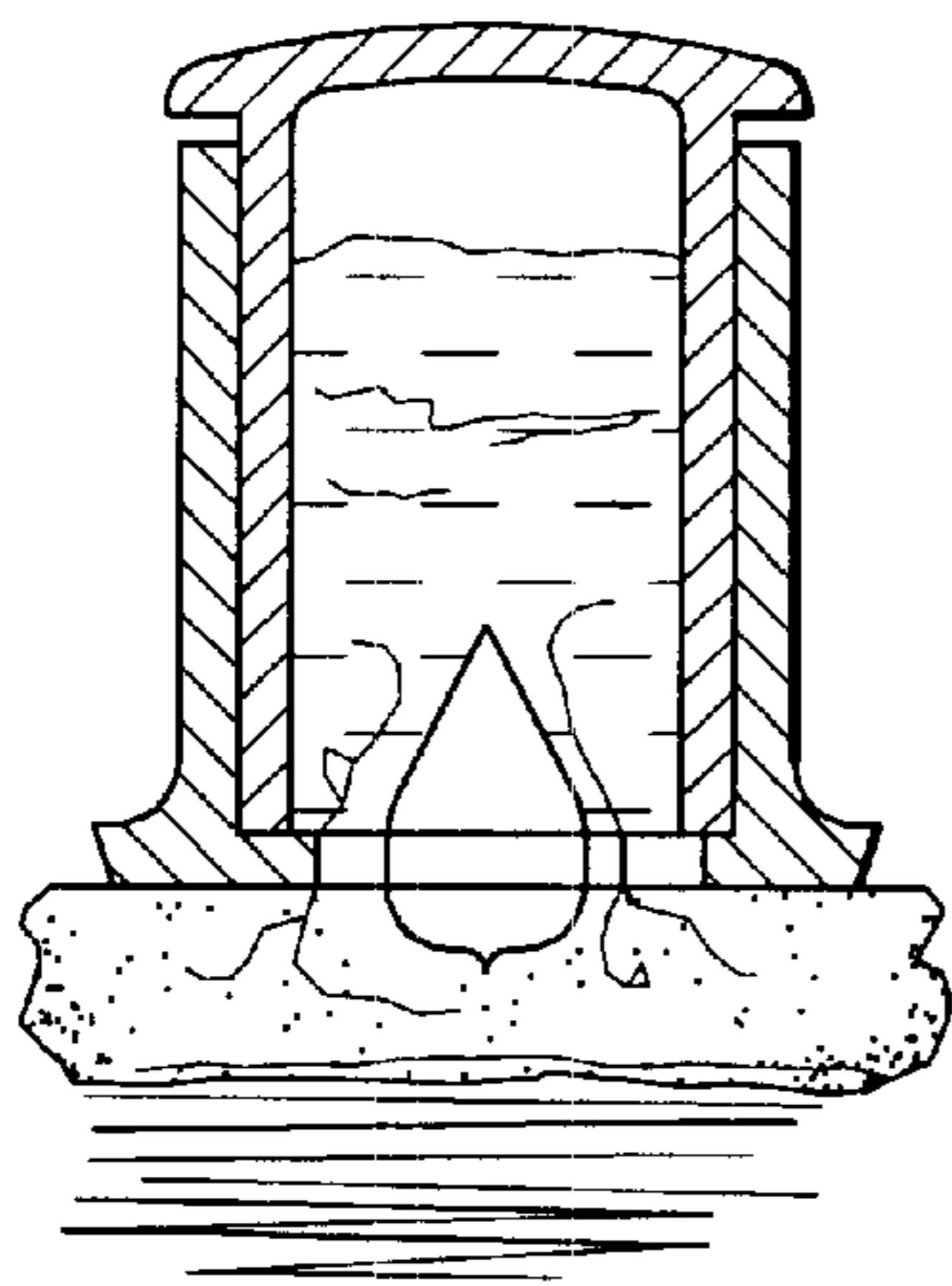

FIG. 3C

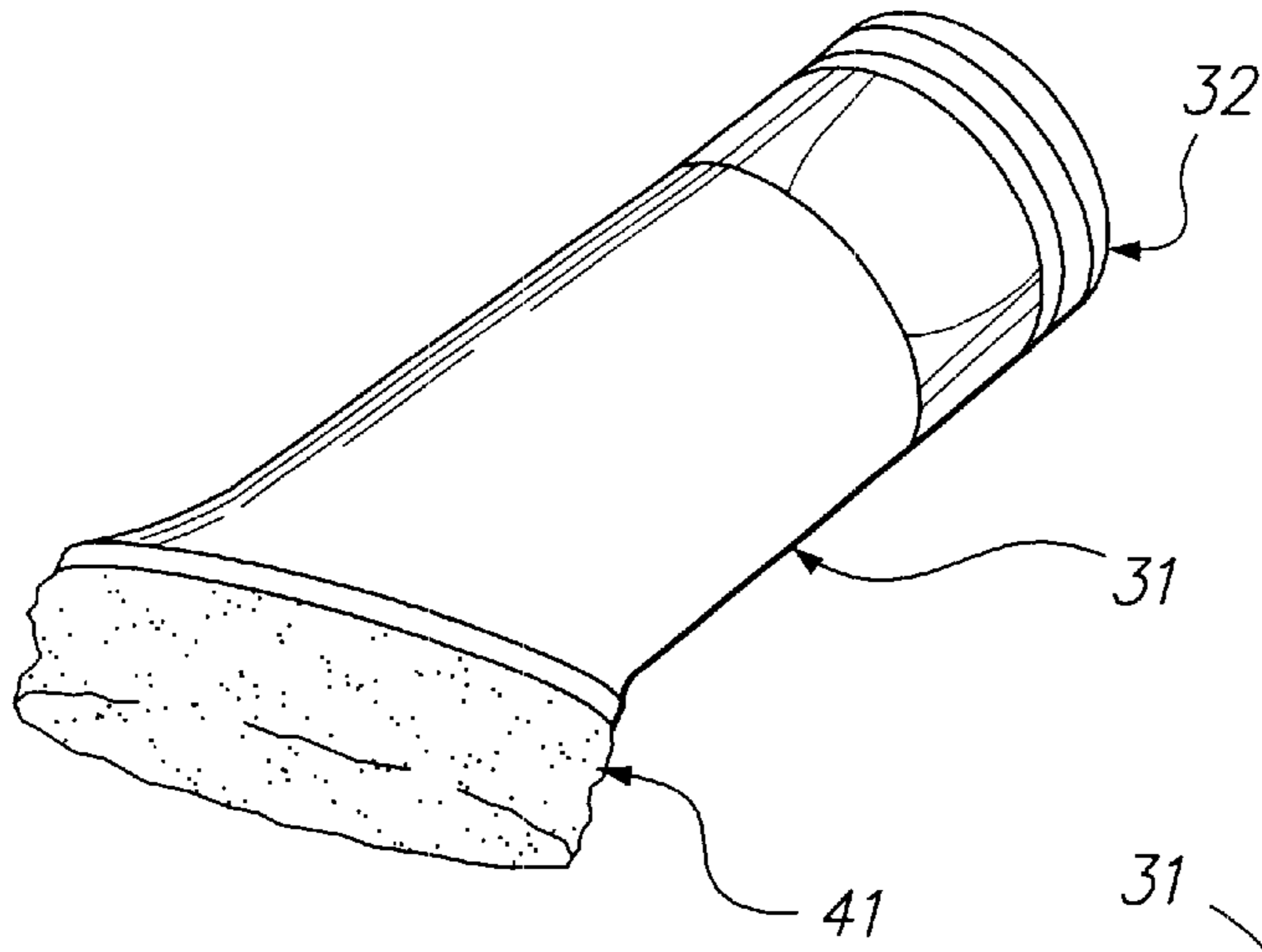

FIG. 4A

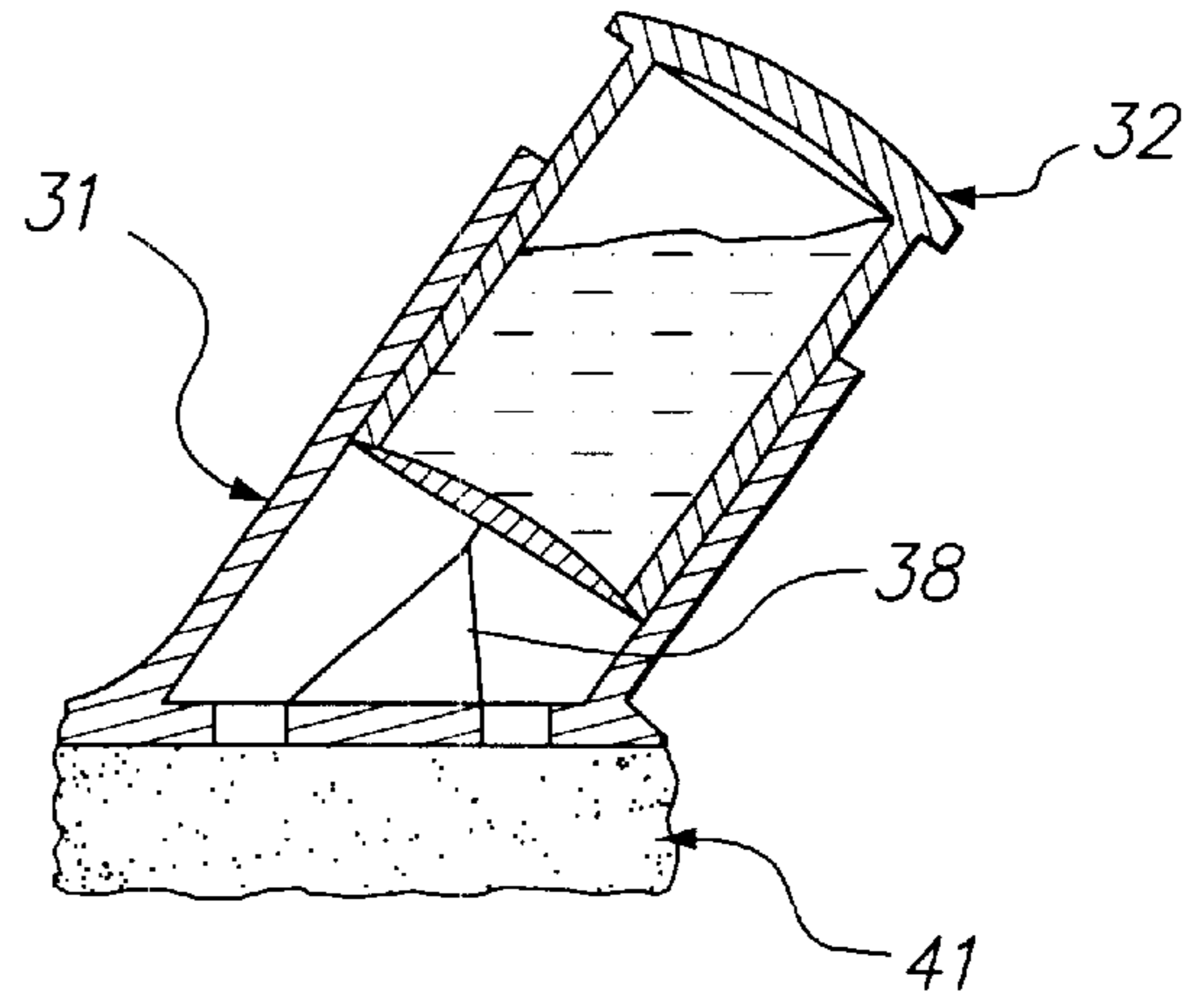

FIG. 4B

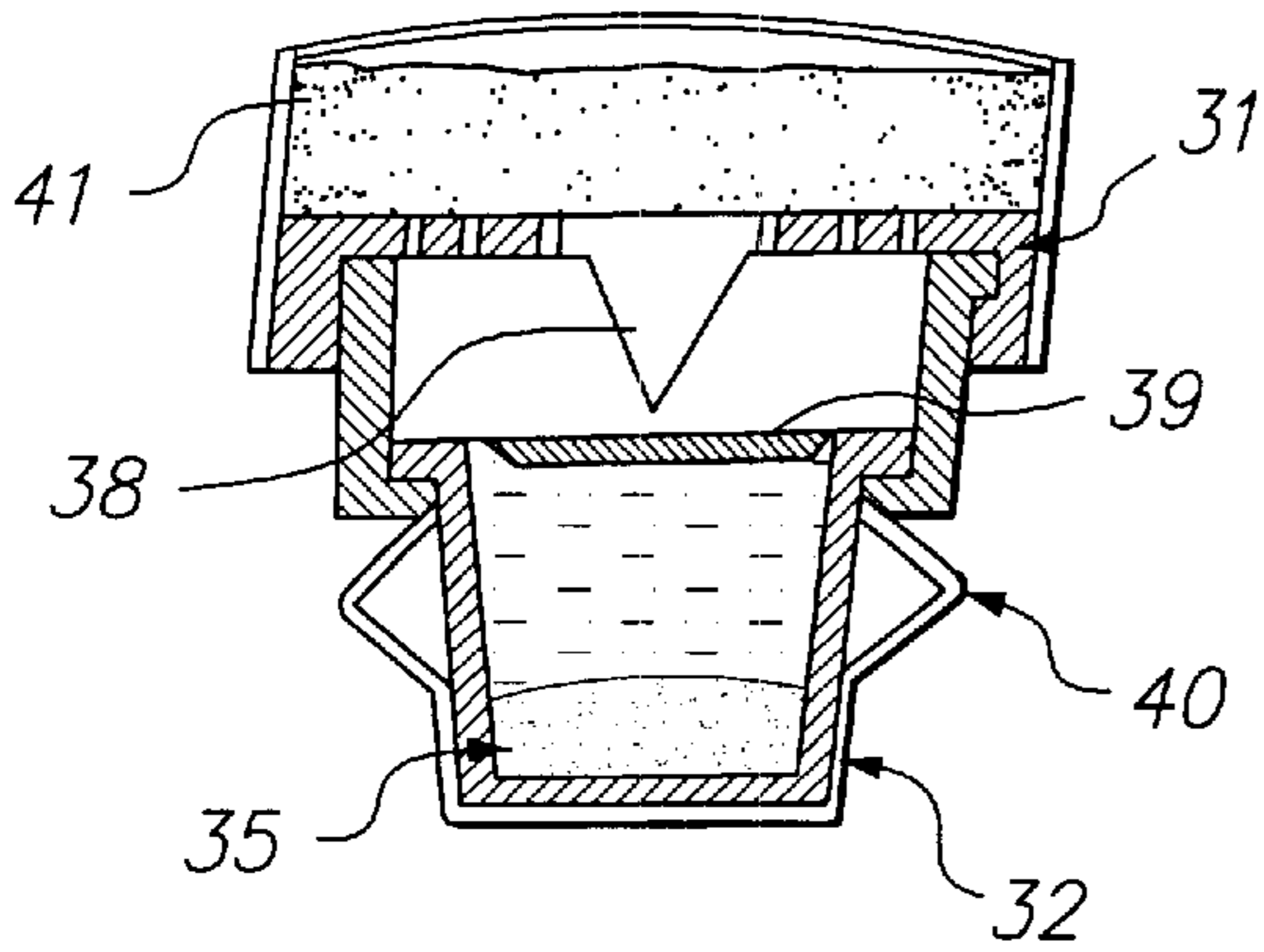

FIG. 5A

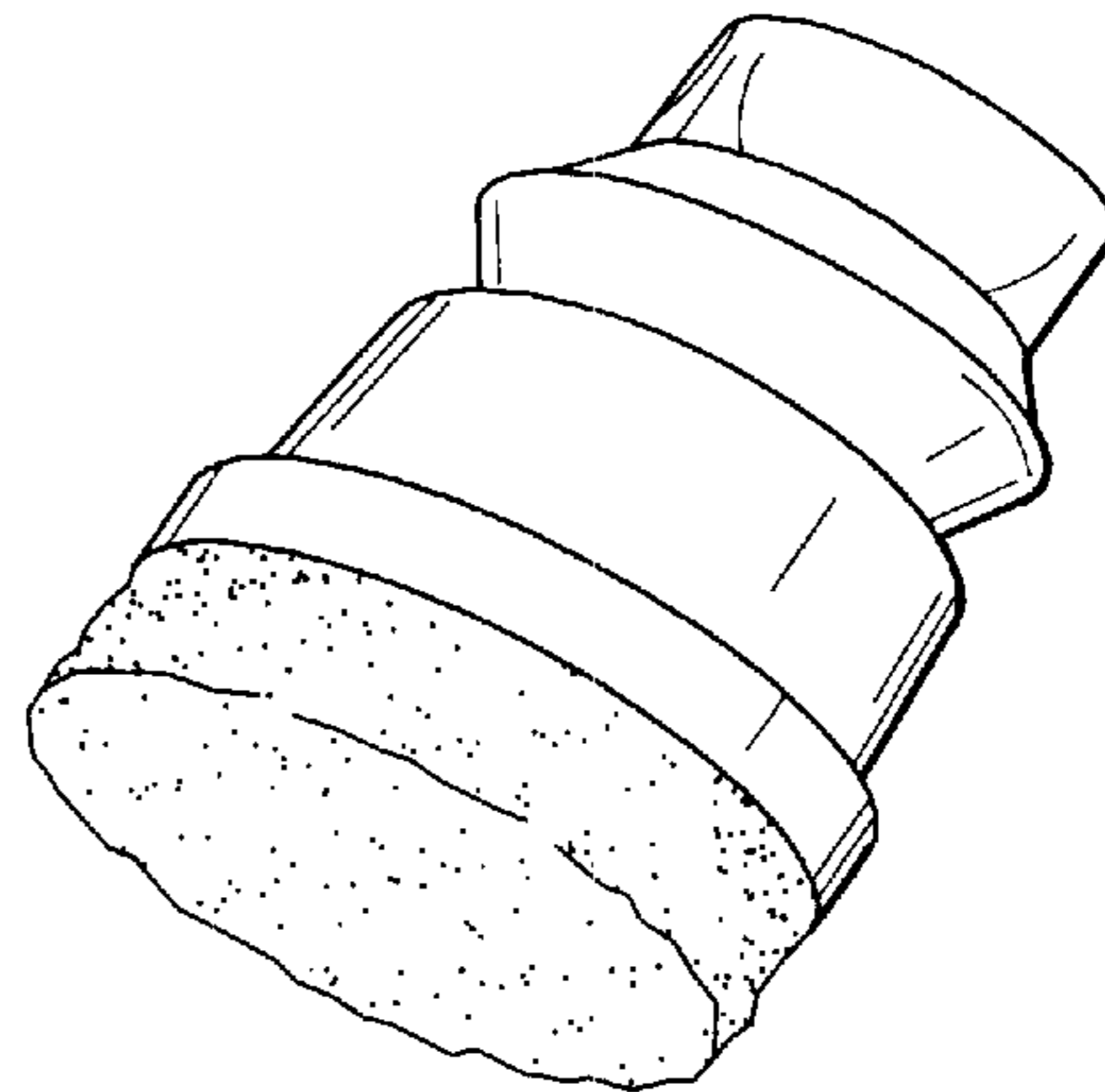

FIG. 5B

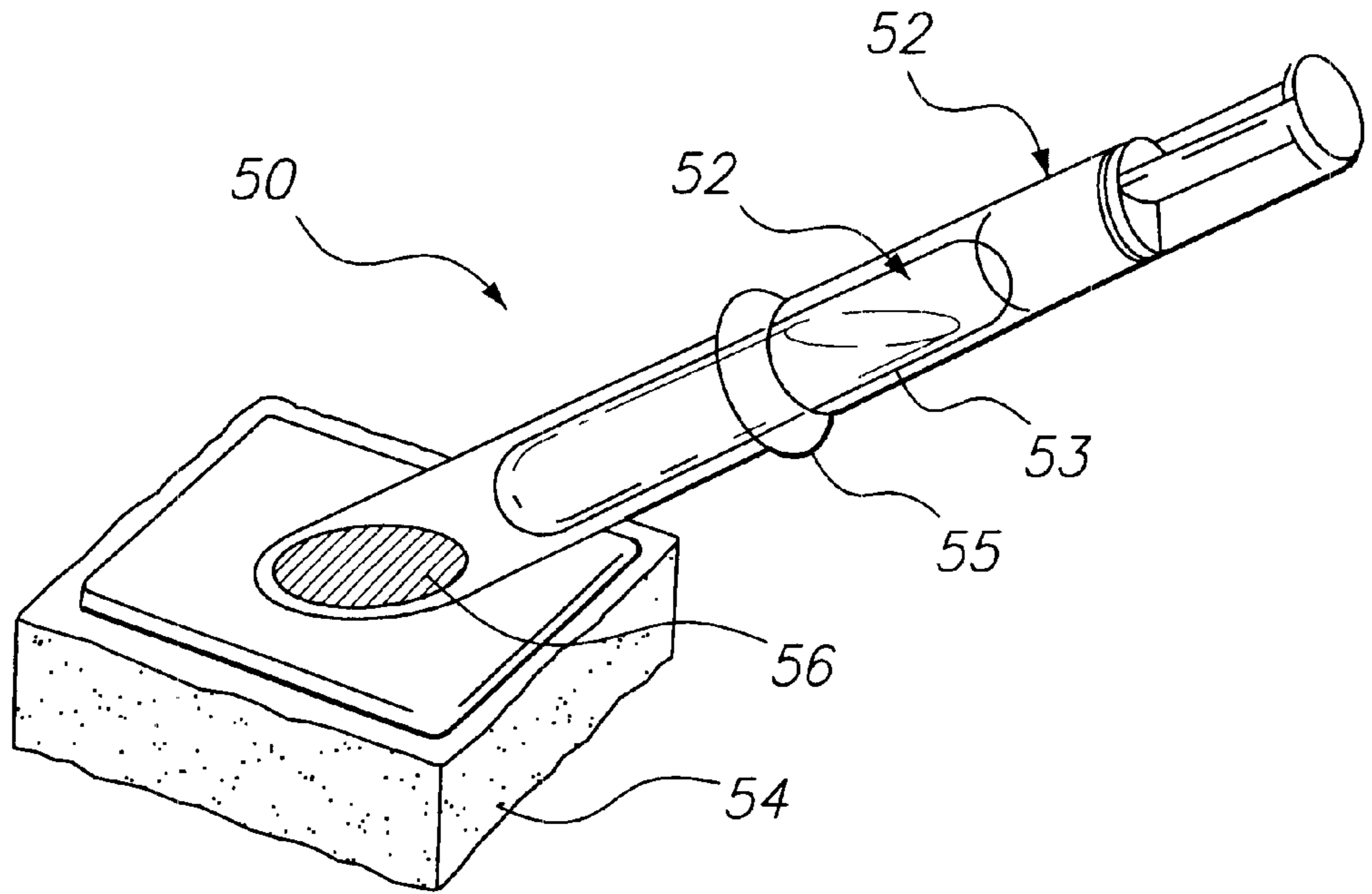

FIG. 6A

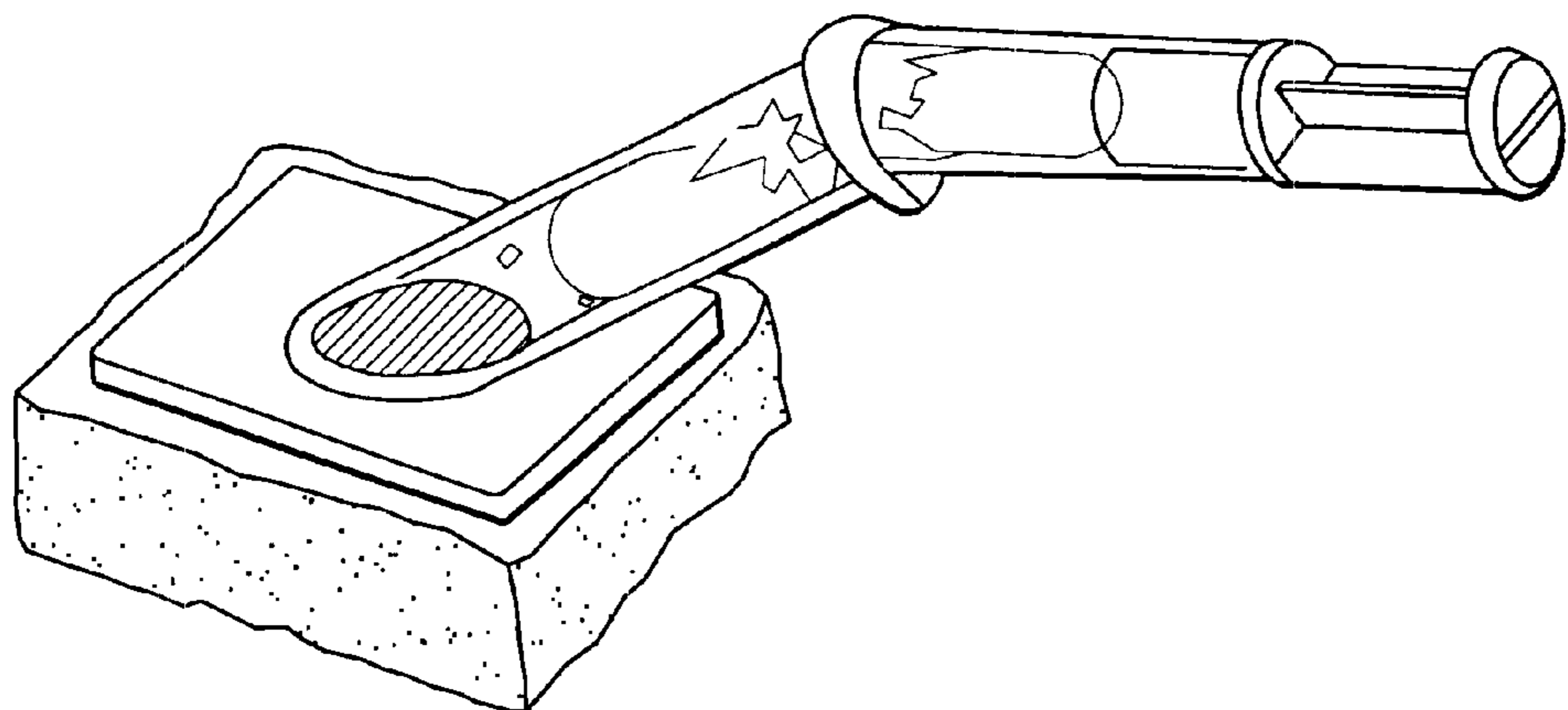

FIG. 6B

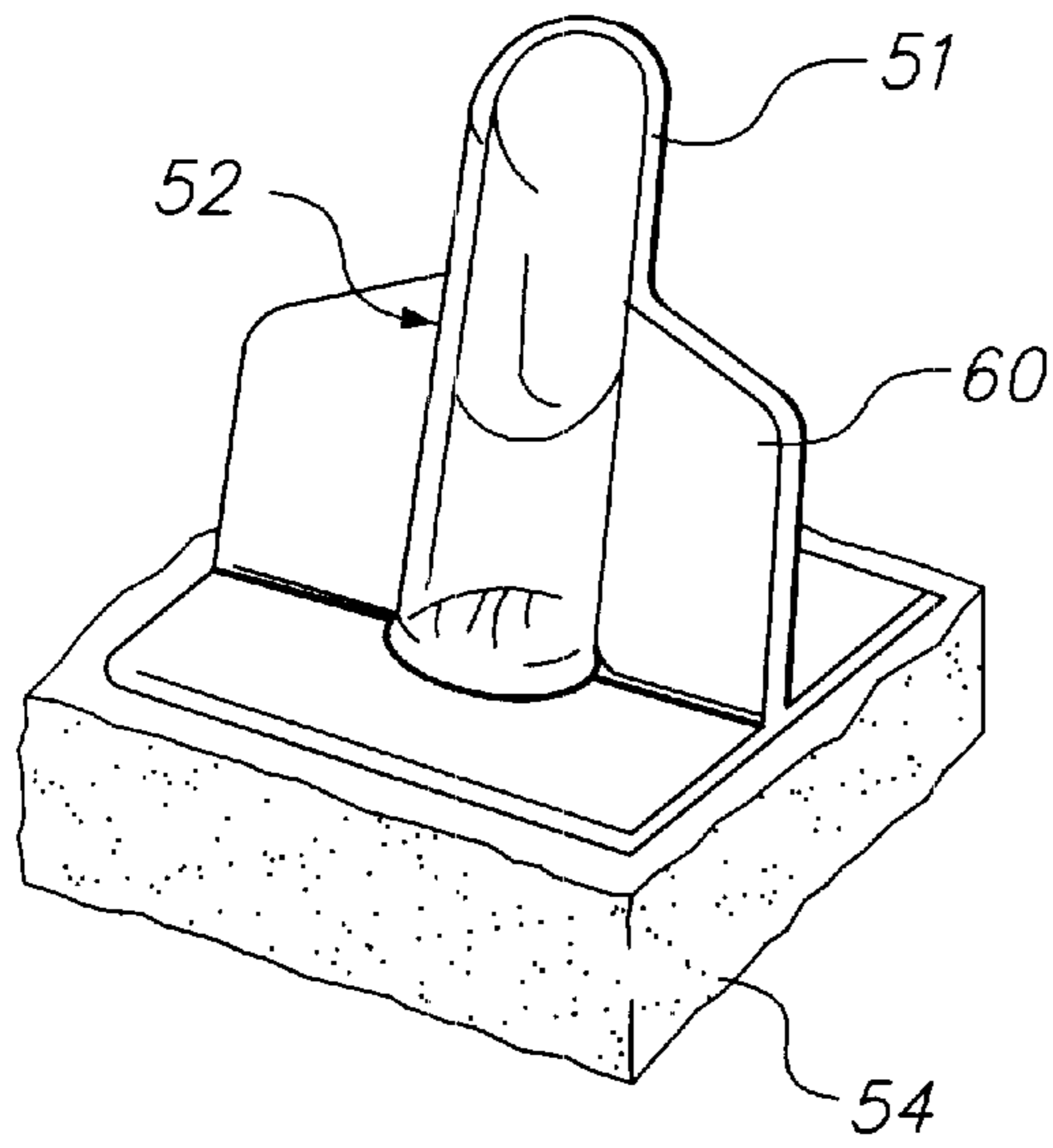

FIG. 7A

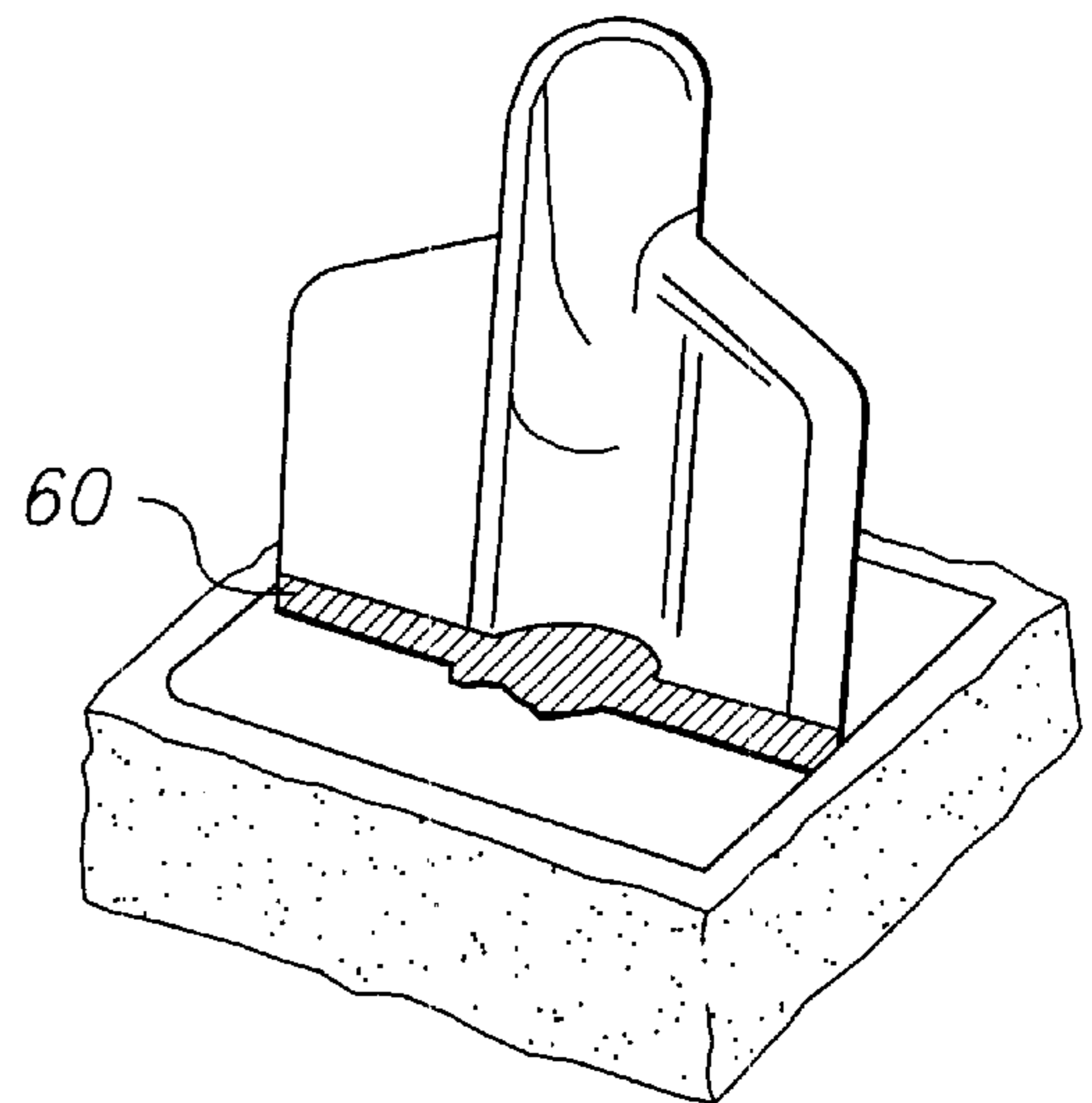

FIG. 7B

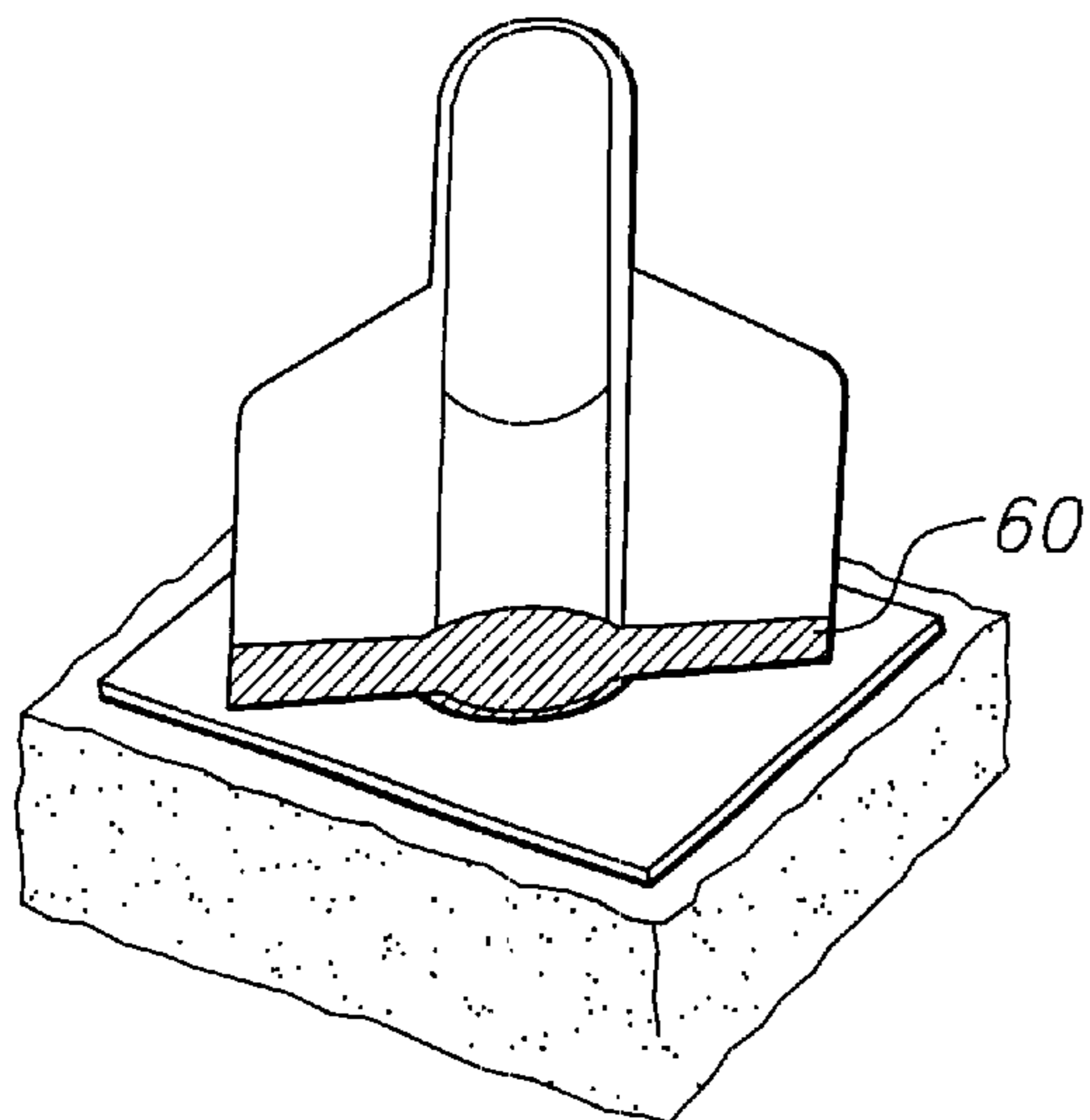

FIG. 7C

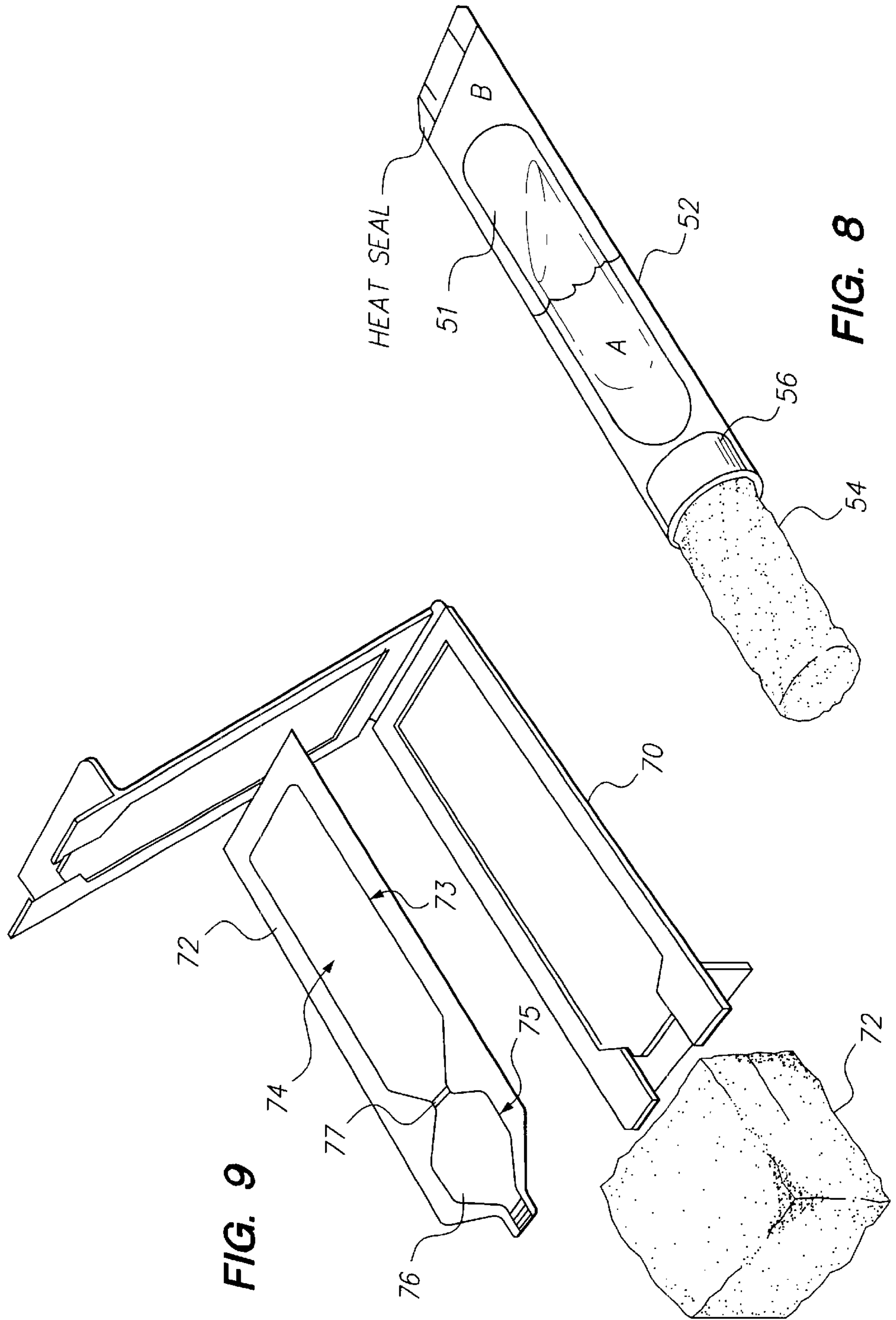

FIG. 9

FIG. 8

**KITS CONTAINING CYANOACRYLATE
COMPOSITIONS COMPRISING AN
ANTIMICROBIAL AGENT**

**CROSS-REFERENCE TO RELATED
APPLICATIONS**

This application is a divisional of application No. 09/185, 227, now abandoned, filed Nov. 3, 1998 which, in turn, is a continuation-in-part of application No. 08/962,869 filed Nov. 3, 1997 now U.S. Pat. No. 6,090,397.

BACKGROUND OF THE INVENTION

Field of the Invention

This invention is directed to kits of parts comprising in a first container a cyanoacrylate prepolymer composition and in a second container a compatible antimicrobial agent. The kit may additionally contain an applicator means for applying the composition to mammalian skin. These kits provide for compositions useful in situ formation of antimicrobial polymeric cyanoacrylate films on mammalian skin which films are useful as wound dressings, wound bandages, surgical incise drapes, and the like.

References

The following publications, patent applications and patents are cited in this application as superscript numbers:

- ¹ Hawkins, et al., *Surgical Adhesive Compositions*, U.S. Pat. No. 3,591,676, issued Jul. 6, 1971
- ² Halpern, et al., *Adhesive for Living Tissue*, U.S. Pat. No. 3,667,472, issued Jun. 6, 1972
- ³ McIntire, et al., *Process for the Preparation of Poly(α -Cyanoacrylates)*, U.S. Pat. No. 3,654,239, issued Apr. 4, 1972
- ⁴ Barley, et al., *Methods for Treating Non-Suturable Wounds by Use of Cyanoacrylate Adhesives*, International Patent Application Publication No. WO 93/25196, published Dec. 23, 1993
- ⁵ Barley, et al., *Methods for Treating Suturable Wounds by Use of Sutures and Cyanoacrylate Adhesives*, U.S. Pat. No. 5,254,132, issued Oct. 19, 1993
- ⁶ Barley, et al., *Methods for Reducing Skin Irritation From Artificial Devices by Use of Cyanoacrylate Adhesives*, U.S. Pat. No. 5,653,789, issued Aug. 5, 1997
- ⁷ Rabinowitz, et al., *Method of Surgically Bonding Tissue Together*, U.S. Pat. No. 3,527,224, issued Sep. 8, 1970
- ⁸ Kronenthal, et al., *Surgical Adhesives*, U.S. Pat. No. 3,995,641, issued Dec. 7, 1976
- ⁹ Davydov, et al., *Medical Adhesive*, U.S. Pat. No. 4,035,334, issued Jul. 12, 1977
- ¹⁰ Waniczek, et al., *Stabilized Cyanoacrylate Adhesives Containing Bis-Trialkylsilyl Esters of Sulfuric Acid*, U.S. Pat. No. 4,650,826, issued Mar. 17, 1987
- ¹¹ Askill, et al., *Methods for Draping Surgical Incision Sites* U.S. Pat. No. 5,730,994, issued Mar. 24, 1998
- ¹² Greff, et al., *Cyanoacrylate Adhesive Compositions*, U.S. Pat. No. 5,480,935, issued Jan. 2, 1996
- ¹³ Hagen, et al., *A Comparison of Two Skin Preps Used in Cardiac Surgical Procedures*, AORN Journal, 62(3):393-402 (1995)
- ¹⁴ Ritter, et al., *Retrospective Evaluation of an Iodophor-Incorporated Antimicrobial Plastic Adhesive Wound Drape*, Clinical Orthopedics and Related Research, pp. 307-308 (1988)
- ¹⁵ Osuna, et al., *Comparison of an Antimicrobial Adhesive Drape and Povidone-Iodine Preoperative Skin Preparation in Dogs*, Veterinary Surgery, 21(6):458-462 (1992)
- ¹⁶ O'Sullivan, et al., *High Viscosity Cyanoacrylate Adhesive Compositions, and Process for Their Preparation*, U.S. Pat. No. 4,038,345, issued Jul. 26, 1977

- ¹⁷ Beller, et al., *Process for the Preparation of Iodine-Polyvinylpyrrolidone by Dry Mixing*, U.S. Pat. No. 2,706,701, issued Apr. 19, 1955
- ¹⁸ Hosmer, *Process of Stabilizing Polyvinylpyrrolidone*, U.S. Pat. No. 2,826,532, issued Mar. 11, 1958
- ¹⁹ Siggin, *Preparation of Iodine Polyvinylpyrrolidone Adducts*, U.S. Pat. No. 2,900,305, issued Aug. 18, 1958
- ²⁰ Joyner, et al., *Plasticized Monomeric Adhesive Compositions and Articles Prepared Therefrom*, U.S. Pat. Nos. 2,784,127, issued Mar. 5, 1957
- ²¹ Columbus, et al., *Adhesive Cyanoacrylate Compositions with Reduced Adhesion to Skin*, U.S. Pat. No. 4,444,933, issued Apr. 24, 1984
- ²² Leung, et al., *Biocompatible Monomer and Polymer Compositions*, U.S. Pat. No. 5,328,687, issued Jul. 12, 1994
- ²³ Byram, et al., *Use of Cyanoacrylate Adhesive Compositions to Inhibit Acute Radiation-Induced Skin Damage*, U.S. Pat. No. 5,554,365, issued Sep. 10, 1996.
- ²⁴ Leplyanin, *Medical and Surgical Adhesive Composition and Process for Its Preparation*, International Application Publication No. WO 96/23532 published Aug. 8, 1996
- ²⁵ Tighe, et al., *Use of Cyanoacrylate Adhesives For Providing A Protective Barrier Film For The Skin*, U.S. Pat. No. 5,580,565, issued on Dec. 3, 1996.
- ²⁶ Cardarelli, et al., *Film Forming Antimicrobial Material*, U.S. Pat. No. 4,374,126, issued Feb. 15, 1983
- ²⁷ Barnes, *Biocidal Complex and Dressing Formed Therefrom*, U.S. Pat. No. 5,051,256, issued Sep. 24, 1991
- ²⁸ Dell, *Film-Forming Composition Containing an Antimicrobial Agent and Methods*, U.S. Pat. No. 4,542,012, issued Sep. 17, 1985
- ²⁹ Brink, et al., *Film-Forming Emulsion Containing Iodine and Methods of Use*, U.S. Pat. No. 5,173,291, issued Dec. 22, 1992
- ³⁰ Khan, et al., *Preparation of a Skin Surface for a Surgical Procedure*, U.S. Pat. No. 5,547,662, issued Aug. 20, 1996
- ³¹ Blum, et al., *In vitro Determination of the Antimicrobial Properties of Two Cyanoacrylate Preparations*, J. Dent. Res., 54(3):500-503 (1975)
- ³² Greff et al., *Cyanoacrylate Compositions Comprising an Antimicrobial Agent*, U.S. Pat. No. 5,684,042, issued Nov. 4, 1997
- ³³ Greff et al., *Cyanoacrylate Compositions Comprising an Antimicrobial Agent*, U.S. patent application No. 08/912,681, filed Aug. 18, 1997
- ³⁴ Mixon, U.S. Pat. No. 5,069,907
- ³⁵ Greff, et al., *Methods for Sterilizing Cyanoacrylate Compositions*, U.S. Pat. No. 6,248,800 which issued on Jun. 19, 2001.

All of the above publications, patent applications and patents are herein incorporated by reference in their entirety to the same extent as if each individual publication, patent application or patent was specifically and individually indicated to be incorporated by reference in its entirety.

State of the Art

Cyanoacrylate esters have been disclosed for a variety of topical uses on mammalian skin including use as a replacement or adjunct for sutures or staples in closing the dermal layer of an incision after surgery.^{1,2,5} Other disclosed topical uses include use as a hemostat³, use in covering small non-suturable wounds on skin surfaces⁴, use in inhibiting surface skin irritation arising from friction between the skin surface and artificial devices such as tapes, prosthetic devices, casts, etc.⁶ and use in inhibiting acute radiation-

induced skin damage.²³ Still another topical use of cyanoacrylate esters is its use in the in situ formation of a surgical incise drape.¹¹ In each case, when topically applied to mammalian skin, the cyanoacrylate rapidly polymerizes, typically within a minute, to form a coherent polymeric film which strongly adheres to the skin.

Cyanoacrylate esters suggested for such uses include the following structures:

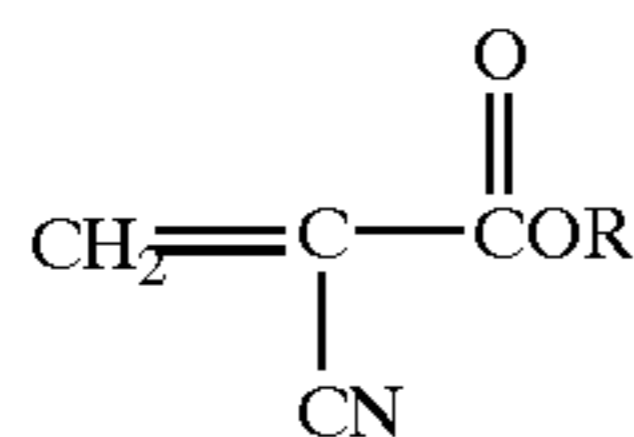

wherein R is an alkyl or other suitable substituent. Such cyanoacrylate esters are disclosed in, for example, U.S. Pat. Nos. 3,527,224; 3,591,676; 3,667,472; 3,995,641; 4,035,334; and 4,650,826.^{1,2,7-10}

Cyanoacrylate ester compositions for topical skin application typically are formulated to contain both a plasticizer to enhance flexibility of the resulting polymeric film and a polymerization inhibitor to avoid premature polymerization of the composition. When employed topically on mammalian skin, Greff et al.¹² disclose that the cyanoacrylate composition preferably employs from about 50 to about 500 ppm sulfur dioxide as the polymerization inhibitor and from about 18–25 weight percent of a biocompatible plasticizer such as dioctyl phthalate.

Notwithstanding the beneficial properties associated with such cyanoacrylate ester compositions and their suitability for topical applications, these compositions do not possess a sufficient antimicrobial activity including activity against microbial spores³¹ and, accordingly, cannot assure reductions in microbial populations on mammalian skin surface either under or adjacent to a polymeric cyanoacrylate film formed in situ on the skin.

Many of the uses of cyanoacrylate ester compositions enumerated above would, however, significantly benefit by additional antimicrobial property in the polymer film. For instance, covering small non-suturable wounds on skin surfaces with a polymeric cyanoacrylate film having antimicrobial activity would mitigate against possible wound infection. Likewise, when used as a surgical (incise) drape, such films would reduce microbial populations under and adjacent to the drape including those at the incision site and, accordingly, would reduce the risk of post-operative infection. Such is the basic premise of commercial surgical drapes containing an antimicrobial agent impregnated directly into the drape or an adhesive layer attached thereto where it was hoped that this agent would be released onto the skin surface to inhibit microbial growth.^{13,14} Osuna, et al.¹⁵ report, however, that when the antimicrobial agent is incorporated into the adhesive layer, the adhesive does not release sufficient amounts of the impregnated agent to be, by itself, antimicrobial.

As noted above, cyanoacrylate esters do not possess adequate antimicrobial activity and, accordingly, incorporation of antimicrobial properties into the cyanoacrylate polymeric film necessitates, of course, that an antimicrobially effective amount of an antimicrobial agent be incorporated into the prepolymeric cyanoacrylate composition and that sufficient amounts of this agent be released from the polymeric cyanoacrylate film onto the skin to achieve an antimicrobial effect. The incorporation of such an antimicrobial agent into the cyanoacrylate composition is problematic at best because several disparate criteria must be simulta-

neously met. First, the antimicrobial agent must be soluble or dispersible in the cyanoacrylate composition at the concentrations necessary to effect antimicrobial properties. Second, the antimicrobial agent employed must not cause premature polymerization of the cyanoacrylate ester composition. Third, the antimicrobial agent employed must not prevent in situ polymerization of the cyanoacrylate composition when applied to the skin. Fourth, the antimicrobial agent must be compatible with the intended use of the polymeric film by not inhibiting formation of a flexible, durable film. Fifth, the impregnated antimicrobial agent must be released from the polymerized film in situ on the patient's skin in sufficient amounts to be antimicrobial.

Because of these disparate properties, many conventional antimicrobial agents are unsuitable for use in the prepolymeric compositions of this invention and typically the prior art has incorporated an antimicrobial agent into a solution or emulsion of the formed polymer or by direct mixing in the polymer melt (see, for example, Mixon³⁴).

When an antimicrobial agent is incorporated into a solution/emulsion, placement of the solution/emulsion on the patient's skin followed by subsequent evaporation of the solvent results in a polymer film formed on the skin which film is permeated with the antimicrobial agent.^{26,28-29} Since the polymer is preformed prior to application to the skin, these solutions/emulsions reduce the effective adherence of the polymer film to the skin and, accordingly, could lead to premature lifting or removal of the film from the skin. Moreover, the use of water and other solvents in the emulsion or solution can lead to slow drying times for the film with the concurrent difficulty in determining when or if the solvent has evaporated sufficiently to provide a polymer film on the patient's skin.³⁰ Organic solvents, on the other hand, forms noxious and potentially flammable fumes.

Kits containing an antimicrobial cyanoacrylate composition and an applicator means have been described in Greff et al., U.S. patent application No. 08/912,681³³. Because the cyanoacrylate composition and the antimicrobial agent are premixed in the kit, such a mixture may have a reduced shelf-life because of the premature polymerization of the cyanoacrylate ester over time (e.g., months). Furthermore, certain antimicrobial agents cannot be formulated in such kits because they cause premature polymerization of the cyanoacrylate ester. Finally, sterilization of the cyanoacrylate/antimicrobial mixture, if desired, may result in premature polymerization of the composition in the container and the various components of the composition may be sterilized. The method of sterilization may be the method set forth in Askill et al.³⁵, U.S. Pat. No. 6,248,800 which issued on Jun. 19, 2001 and which is incorporated by reference.

In view of the clear benefits associated with the incorporation of an antimicrobial agent into the monomeric cyanoacrylate composition prior to application of the cyanoacrylate composition onto mammalian skin, there is a need for a kit which comprises a cyanoacrylate composition in a first container and an antimicrobial agent in a second container such that the composition and agent can be mixed immediately prior to use and the resulting composition applied to mammalian skin.

SUMMARY OF THE INVENTION

This invention is directed to kits of parts comprising a polymerizable cyanoacrylate ester composition in a first container and an antimicrobially effective amount of a compatible antimicrobial agent in a second container. When the contents of these containers are mixed, a polymerizable

antimicrobial cyanoacrylate composition is provided which permits in situ formation of an antimicrobial polymeric cyanoacrylate film on mammalian skin. The specific antimicrobial agent employed is compatible with the cyanoacrylate composition insofar as the antimicrobial agent neither causes premature polymerization nor prevents polymerization of the monomer. Rather a flexible and durable polymeric film is formed in situ on mammalian skin by the mixture of these two compositions and application of the mixture onto the skin. Moreover, in vitro assays evidence that the antimicrobial agent is released from the polymeric film in antimicrobially effective amounts thereby imparting antimicrobial properties to the polymeric film.

Accordingly, in one of its kit aspects, this invention is directed to kit of parts which comprises:

(a) a first container comprising therein a polymerizable cyanoacrylate ester; and

(b) a second container comprising therein an antimicrobially effective amount of a compatible antimicrobial agent.

Optionally, multiple containers can be used to store separate antimicrobial components if a mixture of more than one antimicrobial agent is employed.

Preferably, the polymerizable cyanoacrylate ester is a polymerizable monomer or reactive oligomer of a cyanoacrylate ester. Such monomers and reactive oligomers are sometimes referred to herein simply as "prepolymers" and, in monomeric form, are preferably represented by formula I:

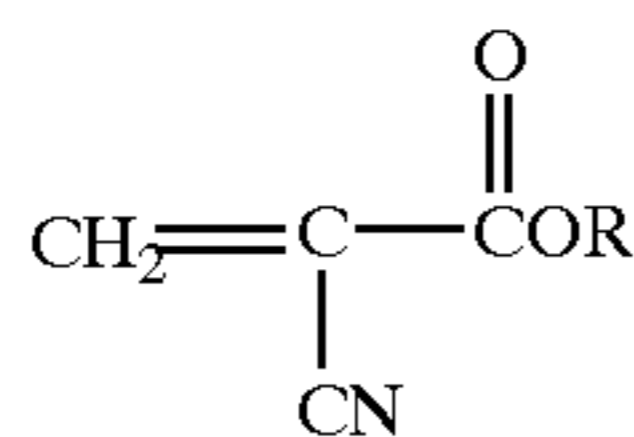

wherein R is selected from the group consisting of:

- alkyl of 1 to 10 carbon atoms,
- alkenyl of 2 to 10 carbon atoms,
- cycloalkyl groups of from 5 to 8 carbon atoms,
- phenyl,
- 2-ethoxyethyl,
- 3-methoxybutyl,
- and a substituent of the formula:

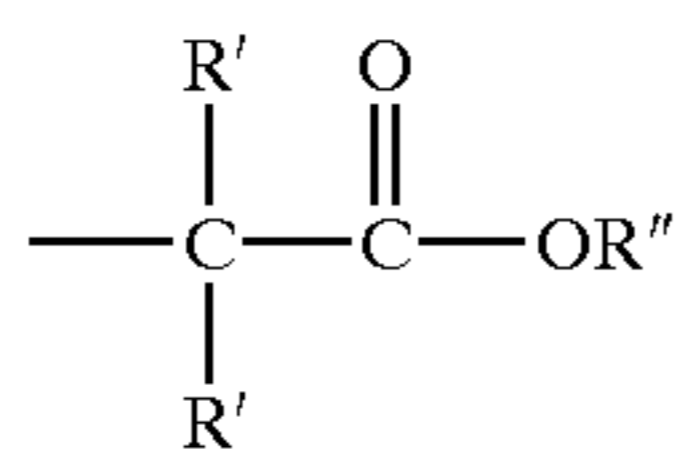

wherein each R' is independently selected from the group consisting of: hydrogen and methyl, and R'' is selected from the group consisting of:

- alkyl of from 1 to 6 carbon atoms,
- alkenyl of from 2 to 6 carbon atoms,
- alkynyl of from 2 to 6 carbon atoms,
- cycloalkyl of from 3 to 8 carbon atoms,
- aralkyl selected from the group consisting of benzyl, methylbenzyl and phenylethyl,
- phenyl, and
- phenyl substituted with 1 to 3 substituents selected from the group consisting of hydroxy, chloro, bromo, nitro, alkyl of 1 to 4 carbon atoms, and alkoxy of from 1 to 4 carbon atoms.

More preferably, in the cyanoacrylate esters of formula I, R is alkyl of from 2 to 10 carbon atoms and still more preferably an alkyl of from 4 to 10 carbon atoms. Even more preferably, R is butyl, pentyl, octyl, decyl or mixtures thereof and most preferably R is n-butyl.

The kit of parts preferably further comprises an effective amount of polymerization inhibitors and a biocompatible plasticizer. Suitable polymerization inhibitors are well known in the art and include 4-methoxyphenol (50 to 1000 ppm based on weight of composition absent any antimicrobial agent) and sulfur dioxide (50 to 1000 ppm based on weight of composition absent any antimicrobial agent). Other preferred polymerization inhibitors include acid inhibitors, e.g., glacial acetic acid and other organic acids, and free radical inhibitors (e.g. hydroquinones, hindered phenols) and the like which can be used alone or in combination with 4-methoxyphenol and/or SO₂.

The preferred biocompatible plasticizer is dioctyl phthalate or C₂-C₄-acyl tri-n-alkyl (C₁-C₆) citrates. The plasticizer is preferably employed at from about 18 to 25 weight percent based on the total weight of the composition absent the antimicrobial agent.

In one embodiment, the first container of the kit which comprises the cyanoacrylate composition, further comprises the polymerization inhibitor and the biocompatible plasticizer.

In another embodiment, the kit of parts further comprises an applicator means for applying the composition onto mammalian skin which, preferably, is an integral part of one of the containers employed in the kit.

DESCRIPTION OF THE DRAWINGS

FIGS. 1A and 1B are a top plan view of a kit of parts comprising a first container having solid PVP-I₂ and a second container containing a polymerizable cyanoacrylate composition, which containers can be mixed at the appropriate time to obtain a polymerizable antimicrobial cyanoacrylate composition.

FIGS. 2A, 2B are a top plan view of a another kit of parts. FIG. 2A illustrates a container comprising a first and second compartment containing a polymerizable cyanoacrylate composition and tetracycline hydrochloride separated by a temporary barrier. FIG. 2B illustrates the second container.

FIGS. 3A, 3B and 3C illustrate another kit of parts. FIG. 3A is a perspective view of the kit. FIG. 3B is a cross-section through the kit with the temporary seal intact. FIG. 3C is a cross-section through the kit after the temporary seal is broken.

FIGS. 4A and 4B illustrate another embodiment of the kit of parts. FIG. 4A is a perspective view of the kit and FIG. 4B is a cross-sectional of the kit with the temporary seal intact.

FIGS. 5A and 5B illustrate another kit of parts. FIG. 5A is a cross-section of the kit. FIG. 5B is a perspective view of the kit.

FIGS. 6A and 6B illustrate another kit of parts comprising a first frangible container enclosed within a second container. FIG. 6A is a cross-section of the kit with the first container intact. FIG. 6B is a cross-section of the kit after the second container is bent, breaking the first container and releasing its contents into the second container.

FIGS. 7A, 7B and 7C illustrate another embodiment of the kit of parts.

FIG. 8 is a cross-section of another kit of parts.

FIG. 9 is an exploded cross-sectional view of another kit of parts.

DETAILED DESCRIPTION OF THE
PREFERRED EMBODIMENTS

This invention is directed, in part, to a kit of parts comprising therein a first container comprising a cyanoacrylate composition and a second container comprising therein an antimicrobially effective amount of a compatible antimicrobial agent. However, prior to discussing this invention in further detail, the following terms will first be defined.

Definitions

As used herein, the following terms have the following meanings:

The term "cyanoacrylate ester compositions" or "cyanoacrylate compositions" refers to polymerizable formulations comprising polymerizable cyanoacrylate ester monomers and/or oligomers which, in their monomeric form, are preferably compounds represented by formula I as described above. Such compounds have been described in Greff et al.^{32,33} which are incorporated by reference herein.

Preferably, in formula I, R is an alkyl group of from 2 to 10 carbon atoms and more preferably an alkyl group of from 4 to 10 carbon atoms including, by way of example, ethyl, n-propyl, iso-propyl, n-butyl, iso-butyl, sec-butyl, n-pentyl, iso-pentyl, n-hexyl, iso-hexyl, 2-ethylhexyl, n-heptyl, n-octyl, nonyl, and decyl. More preferably, R is butyl, pentyl, octyl or decyl and most preferably, R is n-butyl. Mixtures of such compounds can also be employed.

Polymerizable cyanoacrylate esters are known in the art and are described in, for example, U.S. Pat. Nos. 3,527,224; 3,591,676; 3,667,472; 3,995,641; 4,035,334; and 4,650,826^{1,2,7-10} the disclosures of each are incorporated herein by reference in their entirety.

A particularly preferred cyanoacrylate ester for use in the invention is n-butyl-2-cyanoacrylate.

The polymerizable cyanoacrylate ester compositions described herein rapidly polymerize in the presence of water vapor or tissue protein, and the cyanoacrylate bonds human skin tissue without causing histotoxicity or cytotoxicity.

Such polymerizable cyanoacrylate esters are sometimes referred to herein as prepolymers and compositions comprising such esters are sometimes referred to herein as prepolymer compositions.

The term "antimicrobial agent" refers to agents which destroy microbes (i.e., bacteria, fungi, viruses, parasites and microbial spores) thereby preventing their development and pathogenic action.

The term "compatible antimicrobial agent" means an antimicrobial agent which is compatible with the cyanoacrylate composition insofar as the antimicrobial agent causes neither premature polymerization nor prevents polymerization of the polymerizable cyanoacrylate composition in situ.

The term "premature polymerization" means that the mixture of the cyanoacrylate and antimicrobial agent polymerizes so quickly in the container that the mixture cannot be effectively applied to mammalian skin prior to polymerization. Preferably polymerization of the cyanoacrylate composition in the container does not occur within about 30 minutes of mixing of the antimicrobial agent with the cyanoacrylate composition. More preferably, the antimicrobial agent does not cause polymerization in the container of the cyanoacrylate composition within about 15 minutes of mixing.

Suitable compatible antimicrobial agents include the antimicrobial complexes of iodine molecules with a biocompatible polymer, hexachlorophene, tetracycline hydrochloride and the like.

Such antimicrobial complexes of iodine molecules with a biocompatible polymer preferably include polyvinylpyrrolidone polymers which are also referred to under the common name of Povidone or PVP (commercially available from BASF, Mt. Olive, N.J., USA), copolymers of vinylpyrrolidone and vinyl acetate, copolymers of vinylpyrrolidone and vinyl acetate cross-linked with polyisocyanates, copolymers of vinylpyrrolidone and vinyl functionalities, polymers of pyrrolidone²⁷ and the like. Preferably, the iodine containing polymer is Povidone Iodine which is commercially available from a number of sources.

The term "a biocompatible polymer" refers to polymers which, as iodine complexes (adducts), are compatible with in vivo applications of cyanoacrylate ester compositions onto mammalian skin including human skin. Representative polymers include polyvinylpyrrolidone, copolymers comprising polyvinylpyrrolidone which is optionally crosslinked, and the like. Suitable copolymers include copolymers of polyvinylpyrrolidone and vinyl acetate or other vinyl compounds which copolymers are optionally crosslinked with a polyisocyanate. The molecular weight of these polymers is not critical with number average molecular weights ranging from about 10,000 to about 1,000,000 and preferably from 30,000 to 300,000 being preferred.

The term "a complex of iodine molecules with a biocompatible polymer" refers to an antimicrobial complex formed by the addition of iodine (I₂) to the biocompatible polymer. Such complexes are well known in the art and the resulting complex typically comprises both available iodine and iodine anions. These complexes, on contact with mammalian skin, are antimicrobial apparently by providing for a source of antimicrobial iodine. In any event, such complexes are employed only as starting materials herein and, by themselves, do not form a part of this invention.

These complexes are sometimes referred to herein simply by the term "iodine/polymer complexes". Elemental (solid) iodine, on the other hand, is incompatible with cyanoacrylate compositions because the addition of elemental iodine renders such compositions non-polymerizable on mammalian skin. Accordingly, complexation of the iodine with the biocompatible polymer is apparently essential for compatibility with the cyanoacrylate composition.

A preferred iodine/polymer complex for use in the compositions of this invention is a polyvinylpyrrolidone iodine complex which is described in, for example, U.S. Pat. Nos. 2,706,701, 2,826,532 and 2,900,305¹⁷⁻¹⁹ as well as at pp. 1106-1107 of the Tenth Edition of the Merck Index, Published by Merck & Co., Rahway, N.J., USA (1983) the disclosures of which are incorporated herein by reference in their entirety. This complex is commercially available under the name "povidone-iodine" from BASF, Mt. Olive, N.J., USA.

The term "biocompatible plasticizer" refers to any material which is soluble or dispersible in the cyanoacrylate composition, which increases the flexibility of the resulting polymer film coating on the skin surface, and which, in the amounts employed, is compatible with the skin as measured by the lack of moderate to severe skin irritation. Suitable plasticizers are well known in the art and include those disclosed in U.S. Pat. Nos. 2,784,127²⁰ and 4,444,933²¹ the disclosures of both of which are incorporated herein by reference in their entirety. Specific plasticizers include, by way of example only, acetyl tri-n-butyl citrate (preferably ~20 weight percent or less), acetyl trihexyl citrate (preferably ~20 weight percent or less) butyl benzyl phthalate, dibutyl phthalate, dioctylphthalate, n-butyryl tri-

n-hexyl citrate, diethylene glycol dibenzoate (preferably ~20 weight percent or less) and the like. The particular biocompatible plasticizer employed is not critical and preferred plasticizers include dioctylphthalate and C₂-C₄-acyl tri-n-alkyl (C₁-C₆) citrates.

The term "polymerization inhibitor" refers to any material which is soluble or dispersible in the cyanoacrylate composition and which, in the amounts employed, inhibits the premature polymerization of the composition and is compatible with the skin. Conventional acid inhibitors of cyanoacrylate esters including materials such as sulfur dioxide, glacial acetic acid, organic acids, and the like. The polymerization inhibitor is typically employed in amounts effective to inhibit polymerization until application onto the mammalian skin. Suitable polymerization inhibitors are well known in the art and include sulfur dioxide. Other preferred polymerization inhibitors include free radical inhibitors (e.g. hydroquinones, hindered phenols) and the like which can be used in combination with acid inhibitors such as SO₂. Preferably, the polymerization inhibitor is employed at from about 50 to about 1000 ppm based on the total weight of the composition absent any antimicrobial agent and more preferably from about 100 to 500 ppm.

Compositions

This invention is based on the novel and unexpected discovery that the antimicrobial agents described herein are compatible with cyanoacrylate esters forming a polymerizable composition which, upon polymerization, provides for an antimicrobial cyanoacrylate polymeric film. Compatibility is assessed by the fact that these agents are dispersible in the cyanoacrylate ester composition at antimicrobially effective concentrations and when so employed, do not cause premature polymerization of the cyanoacrylate ester composition and do not prevent effective polymerization of the cyanoacrylate ester composition when applied to mammalian skin. Moreover, the polymerizable cyanoacrylate ester composition comprising such complexes forms a flexible, durable polymeric film having the complex incorporated therein which complex is released from the film in sufficient amounts to provide antimicrobial properties to the film.

The specific amount of antimicrobial agent required to effect antimicrobial properties in the resulting polymeric film can be readily measured by conventional in vitro assays measuring zones of microbial growth inhibition around the film. Zones of inhibition of at least 1 millimeter and preferably 3 millimeters from the edge of the film when tested in the manner of Example 2 below evidence that the polymeric film is antimicrobial. Assessing the amount of antimicrobial agent required in the polymeric film to effect such a zone of inhibition is well within the skill of the art.

When tetracycline is employed as the antimicrobial agent, it is preferably employed as the hydrochloride salt. Such a preference reflects the rapid polymerization of the cyanoacrylate composition when tetracycline hydrate is employed.

When an iodine/polymer complex is employed as the antimicrobial agent, it is preferably added as the commercially available solid composition rather than as the commercially available aqueous or ethanolic solution insofar as the solution can cause premature polymerization of the cyanoacrylate ester which is apparently due to solvent's effects. Preferably, the iodine/polymer complex added is micronized, i.e. each particle is sized to be about 10 microns. Such iodine/polymer complexes are commercially available or can be made by conventional means using a ball mill. Upon addition of the solid iodine/polymer complex to the

cyanoacrylate prepolymer composition, the resulting system is thoroughly mixed to obtain a homogeneous suspension.

The amount of antimicrobial agent added to the cyanoacrylate composition is a sufficient amount such that the resulting polymeric film is antimicrobial. Preferably, from about 1 to about 40 weight percent of the antimicrobial agent is employed based on the total weight of the composition. More preferably, from about 1 to 10 weight percent of tetracycline hydrochloride is employed; from 1 to 15 weight percent of hexachlorophene is employed; and from about 1 to 40 weight percent of the iodine/polymer complex is employed. When the size of the iodine/polymer particles is approximately 30 mesh the amount employed is preferably from about 10 to 30 weight percent. When the size of the iodine/polymer particles is micronized (e.g., approximately 10 μm) the amount employed is preferably from about 1 to 20 weight percent and more preferably from about 3 to 10 weight percent.

The composition of the antimicrobial agent and the cyanoacrylate ester can be formulated to a specific viscosity to meet disparate demands for the intended application of the composition. For example, relatively low viscosities are often preferred where application is to be made to a large surface area (e.g., abdominal surfaces). This preference results from the fact that these forms are less viscous and, accordingly, will permit more facile large surface area application of a thin film. Contrarily, where application is to be made to a specific position on the skin (e.g., elbow surfaces, knee surfaces and the like), higher viscosity compositions, including those containing thixotropic materials, are preferred to prevent "running" of the compositions to unintended locations.

Accordingly, these compositions have a viscosity of from about 2 to 50,000 centipoise at 20° C. For low viscosity applications, viscosity ranges of from about 2 to 1,500 centipoise at 20° C. are preferred. More preferably, the cyanoacrylate ester employed in the composition is almost entirely in monomeric form and the composition has a viscosity of from about 5 to about 500 centipoise at 20° C.

A thickening agent is optionally employed to increase the viscosity of the composition which thickening agent is any biocompatible material which increases the viscosity of the composition. Suitable thickening agents include, by way of example, polymethyl methacrylate (PMMA) or other preformed polymers soluble or dispersible in the composition, a suspending agent such as fumed silica and the like, with PMMA being preferred. Fumed silica is particularly useful in producing a gel for topical application having a viscosity of from about 1500 to 50,000. Suitable thickening agents for the cyanoacrylate compositions described herein also include a polymer of the alkyl cyanoacrylate as disclosed in U.S. Pat. Nos. 3,654,239³ and 4,038,345¹⁶ both of which are incorporated herein by reference in their entirety.

Thickening agents are deemed to be biocompatible if they are soluble or dispersible in the composition and are compatible with the skin as measured by the lack of moderate to severe skin irritation.

The cyanoacrylate composition preferably includes a biocompatible plasticizer and such plasticizers are preferably included from about 10 to 30 weight percent and more preferably from about 18 to 25 weight percent based on the weight of the composition absent the antimicrobial agent. A particularly preferred biocompatible plasticizer for use in the compositions described herein is dioctylphthalate and C₂-C₄-acyl tri-n-alkyl (C₁-C₆) citrates.

The cyanoacrylate ester compositions may additionally contain one or more optional additives such as colorants,

perfumes, rubber modifiers, modifying agents, etc. In practice, each of these optional additives should be both miscible and compatible with the cyanoacrylate composition and the resulting polymer. Compatible additives are those that do not prevent the use of the cyanoacrylates in the manner described herein.

In general, colorants are added so that the polymer layer formed on the skin will contain a discrete and discernible color. Perfumes are added to provide a pleasant smell to the formulation. Rubber modifiers are added to further enhance the flexibility of the resulting polymer layer. The amount of each of these optional additives employed in the composition is an amount necessary to achieve the desired effect.

Additionally, the cyanoacrylate composition can optionally comprise a formaldehyde scavenger compound such as those described by Leung, et al.²² The use of such scavengers has been suggested as enhancing internal in vivo applications of cyanoacrylates.

Still further, it is contemplated that the cyanoacrylate composition can optionally comprise an acrylic monomer that will act as a polymeric plasticizer when it copolymerizes with the cyanoacrylate composition.²⁴

Utility

The methods described herein are useful in forming in situ an antimicrobial polymeric film on the skin surface of a mammalian patient. Such mammalian patients preferably include humans as well as, for example, domestic animals such as horses, cows, dogs, sheep, cats, etc.

The polymeric film finds particular utility in inhibiting microbial contamination thereunder and in the areas immediately adjacent thereto. Accordingly, such polymeric films can be used to topically cover small non-suturable wounds on skin surfaces which wounds do not penetrate through the dermal layer of the skin as in the manner described in Barley, et al.⁴ When so employed, the antimicrobial cyanoacrylate composition is applied over the small non-suturable wound. Upon polymerization, an antimicrobial polymeric film is formed over the wound which provides for antimicrobial properties at the wound surface while also preventing exogenous contaminants from entering the wound.

Additionally, the polymeric films formed from the antimicrobial cyanoacrylate compositions described herein can also be used in the in situ formation of a surgical incise drape in the manner described by Askill, et al.¹¹ When so employed, the in situ formed film strongly adheres to the mammalian skin surface to provide for a surgical incise drape which does not lift during surgery and has antimicrobial properties.

When used as either a small wound covering or as a surgical incise drape, the antimicrobial polymeric film will only adhere to the skin for a period of about 1-4 days after which time it sloughs off. This occurs because the cyanoacrylate polymer adheres only to the uppermost portion of the epidermal layer which is continuously in the process of being sloughed off and replaced by the underlying cells. Accordingly, the antimicrobial cyanoacrylate film need not be removed after in situ formation. However, if removal of the polymeric film is required, such can be accomplished with a material such as acetone (nail polish remover).

Other utilities for the compositions of this invention include their use to form polymeric hemostatic films³, use as protective barriers through which needle punctures or catheter placement occurs, use to form polymeric films in inhibiting surface skin irritation arising from friction between the skin surface and artificial devices such as tapes,

prosthetic devices, casts, etc.⁶, use in forming polymeric films in inhibiting acute radiation-induced skin damage²³, use in treating incontinence and areas adjacent to wounds to stomas²⁵ and use in wound closure materials as a replacement or adjunct to sutures.

Kits

In view of the many different uses for topical application onto mammalian skin, this invention encompasses a kit of parts useful for applying the antimicrobial cyanoacrylate compositions described herein onto mammalian skin. The multi-component system can be used to store the antimicrobial agent in one component of the container and the polymerizable cyanoacrylate composition in the other component. At the appropriate time, the components can be mixed to provide for an antimicrobial, polymerizable cyanoacrylate composition.

In particular, such a kit of parts comprises (a) a first container comprising a polymerizable cyanoacrylate composition and (b) a second container comprising a compatible antimicrobial agent as described above. The kit may further comprise an applicator means for applying onto mammalian skin the antimicrobial polymerizable cyanoacrylate composition obtained by mixing the contents of the two containers. In one embodiment, the applicator means is attached to one of the containers. In another embodiment, the applicator means forms a discrete part of the kit.

In one embodiment, the containers are combined into a single article of manufacture having a barrier between the containers/compartments. This barrier can either be removed or destroyed allowing mixing of the compositions in each of the compartments at the appropriate time. Such barriers include frangible or crushable barriers.

In another embodiment, the first and second containers are separate articles designed to mate with each other. For example, the cyanoacrylate prepolymer composition could be stored in an amber vial sealed with a screw cap and the antimicrobial agent is stored in a second vial which includes a screw mechanism which mates with the screw mechanism on the top of the cyanoacrylate vial. When mixing of the cyanoacrylate prepolymer composition with the antimicrobial agent is intended, the caps are removed from the cyanoacrylate vial and the antimicrobial vial and the vials are attached and the components mixed.

The first container or compartment comprises any compatible material which stores the cyanoacrylate composition without degradation of the container/compartment or prematurely polymerizing the cyanoacrylate prepolymer. Such materials include, by way of example, inorganic materials such as Type I glass (including amber colored glass), ceramics, metals (e.g., aluminum, tin and tin coated tubes), etc. and organic materials such as inert polymers including polyolefins (e.g., high density polyethylene), fluorinated polyolefins, and the like. Examples of suitable containers include those recited in Bolduc, U.S. Pat. No. 5,154,320, which is incorporated herein by reference in its entirety.

The second or further container/compartment contains the antimicrobial and can optionally include glass beads or other similar materials to facilitate mixing of the contents of the two containers when mixing is desired. The container/compartment comprising the antimicrobial agent is prepared from materials which are compatible with the antimicrobial agent or mixture of agents employed therein.

Suitable applicator means include brushes, rollers, aerosols, swabs, foams (e.g., polyethylene foam), packed fibers and the like. A particularly preferred applicator is described in U.S. Pat. No. 4,183,684.

Dispensing units of the general type with which this application is concerned are known in the art. Pertinent in this respect are the dispensing devices described in U.S. Pat. Nos. 4,183,684; 5,409,141; 5,474,209; 4,648,532 and 5,466,220 each of which is incorporated by reference herein.

In one embodiment, one of the containers (e.g. the first container or the second container) and the applicator means are combined into a single article such as a brush affixed to the terminal portion of the container wherein means are employed to prevent premature release of the cyanoacrylate prepolymeric composition. For example, the brush may be overlaid with a removable impermeable barrier. When application of the cyanoacrylate prepolymer composition is intended, the barrier is simply removed.

FIGS. 1A, 1B, 2A, 2B, 3A, 3B, 3C, 4A, 4B, 5A, 5B, 6A, 6B, 7A, 7B, 7C and 8 illustrate various types of containers in which the polymerizable cyanoacrylate composition is separated from the antimicrobial agent prior to mixing.

FIG. 1A illustrates a first container 2 comprising a terminal applicator means 4 and container element 6 which, in this embodiment, comprises glass beads 14 and the requisite amount of solid PVP-I₂ 16. First container 2 has mating threads 18 for mating with cap 8 during storage. Cap 8 is mated to first container 2 during storage in order to retain both the glass beads 14 and PVP-I₂ 16 in container element 6.

FIG. 1B illustrates the second container 10 comprising mating threads 11 which mate with the reciprocal mating threads 18 when the first and second containers 2 and 10 are joined. Container 10 comprises a temporary seal means 12 which seals the polymerizable cyanoacrylate composition 13 within container 10 until mixing with the PVP-I₂ 16 is desired. Suitable temporary seal means include puncturable plastics, glasses, foils, films, etc. as well as peelable plastics, foils, films, etc. In one embodiment, mating means 18 can include a puncturing element (not shown) which can puncture the temporary seal means 12.

When mixing of the first and second containers 2 and 10 is desired, cap 8 is removed from first container 2 and temporary seal means 12 are removed or punctured from second container 10 and the two containers mated via complementary mating threads 18 and 11. Upon mating, the contents are mixed to provide for a homogenous suspension of the PVP-I₂ 16 in the cyanoacrylate composition 13 which can be applied to mammalian skin (not shown) via applicator means 4.

FIGS. 2A and 2B illustrate an alternative means of forming a suitable kit of parts. Specifically, in FIG. 2A, container 20 comprises two compartments 21 and 23 separated by temporary barrier means 26. Compartment 21 comprises glass beads 14 and the requisite amount of tetracycline hydrochloride 19. Compartment 23 comprises polymerizable cyanoacrylate composition 13 as well as mating means 24 and temporary seal means 22. Suitable temporary seal means 22 include, by way of example, puncturable plastics, glasses, foils (aluminum, tin, etc.), films, etc. as well as peelable plastics, foils, films, etc.

FIG. 2B illustrates the second container 28 comprising mating threads 34 which mate with the reciprocal mating threads 24 when the first and second containers 20 and 28 are joined. Container 28 comprises a removable cap 27 which covers applicator tip 25 until application of the mixed composition. In the embodiment illustrated, mating means 29 includes a puncturing element 17 which punctures the temporary seal means 22 during mating.

When mixing of the contents of the first and second compartments 21 and 23 is desired, removal of barrier

means 26 in an appropriate manner (e.g., shaking, squeezing, heating, crushing, etc.) allows for mixing of the components. For example, vigorous shaking of the contents permit the glass beads to break barrier means 26. Mixing in this manner can occur either prior to or after mating of the first and second containers, 20 and 28.

Mating is achieved in the manner set forth above.

Alternatively, in FIGS. 2A and 2B, the tetracycline hydrochloride is stored in second container 28.

FIGS. 3A, 3B and 3C illustrate an alternative means of forming a suitable kit of parts in which the containers are combined into a single article of manufacture having a barrier between the containers or compartments. In FIG. 3A, container 30 comprises two containers 31 and 32, wherein container 32 is slidably engaged within container 31 and a locking means 40. FIG. 3B illustrates that container 32 is closed at one end by a first temporary seal means 33 and is separated into two compartments 36 and 37 by a second temporary seal means 34. Container 31 comprises a suitable puncturing element 38 and an applicator means 41. Compartment 36 comprises polymerizable cyanoacrylate composition 35. Compartment 37 comprises the requisite amount of antimicrobial 39. Suitable temporary seal means 33 and 34 include, by way of example, puncturable plastics, glasses, foils (aluminum, tin, etc.), films, etc.

When mixing of the polymerizable cyanoacrylate composition 35 and the antimicrobial 39 is desired, the removable locking means 40 is removed and container 32 is slidably moved into container 31 such that both the first and second temporary seal means 33 and 34 are punctured by the puncturing element 38. See FIG. 3C. Upon puncturing, the contents are mixed to provide for a homogeneous suspension of the antimicrobial 39 in the cyanoacrylate composition 35 which can then be applied to mammalian skin via the applicator means 41.

FIGS. 4A, and 4B illustrate a further embodiment of the container of FIGS. 3A, 3B, and 3C wherein the applicator means 41 is angled.

FIGS. 5A and 5B illustrate a further embodiment of the container of FIGS. 3A, 3B and 3C wherein the locking means 40 comprises a compressible ring interposed between containers 31 and 32, such that upon compression, both the first and second temporary seal means 33 and 34 are punctured by the puncturing element 38.

The applicator means can be applied to either of the containers.

FIGS. 6A and 6B illustrate a further container 50 comprising a first breakable container 51 located entirely within a second container 52. The first breakable container 51 contains the polymerizable cyanoacrylate composition 53. The second compartment comprises an applicator means 54, a flexible region 55 and the antimicrobial 56. The first breakable container 51 may, for example, be a thin wall glass ampoule

When mixing of the polymerizable cyanoacrylate composition 53 and the antimicrobial 56 is desired, the second container 52 is bent at the flexible region 55, thereby breaking the first container 51. The cyanoacrylate composition 53 is released from the first compartment 51 into the second compartment 52 where it mixes with the antimicrobial 56 which can then be applied to mammalian skin via the applicator means 54. The flexible region may include, for example, a stress riser to aid in breaking the first container 51.

FIGS. 7A, 7B and 7C are perspective views of other embodiments of kit of parts, in which the second container

52 further comprises hollow flanges or fins 60 which are integral to the container and which are engaged with the applicator means 54. Such fins or flanges 60 serve to transfer the mixture of the cyanoacrylate composition and antimicrobial to the applicator means 54.

FIG. 8 is another embodiment of a kit of parts, in which the second container is formed from a tube which is sealed flat at one end with the applicator means 54 located at the opposite end.

FIG. 9 is an exploded cross-sectional view of another kit of parts comprising an outer first container 70, a second flexible container 71 and an applicator means 72. The second flexible container 71 comprises a first compartment 73 containing the cyanoacrylate composition 74 and a second compartment 75 containing the antimicrobial powder 76 with a frangible seal 77 separating the first and second compartments. The second compartment 75 is open at one end, which end is placed in the applicator means 72. When mixing of the cyanoacrylate and the antimicrobial is desired, the frangible seal 77 is broken and the cyanoacrylate composition and the antimicrobial are mixed and applied to the mammalian skin with the applicator means 72.

Multiple component systems can also be used (e.g., a three component system comprising two components each containing a separate antimicrobial agent each stored in separate compartments segregated from each other until time of use as well as a third component storing the cyanoacrylate composition). In another embodiment, the cyanoacrylate polymer is stored in one container, the antimicrobial agent is stored in another container and the biocompatible plasticizer is stored in a third container.

The following examples illustrate certain embodiments of the invention but are not meant to limit the scope of the claims in any way.

EXAMPLE

In the example below, all temperatures are in degrees celsius (unless otherwise indicated) and all percents are weight percent (also unless otherwise indicated) except for percent inhibition which is true mathematical percentage. Additionally, the following abbreviations have the following meanings. If an abbreviation is not defined, it has its generally accepted meaning.

CFU=colony forming units

conc.=concentration

flex.=flexibility

dur.=durability

ml=milliliters

mm=millimeters

ppm=parts per million

PVP-I₂=polyvinylpyrrolidone iodine complex

SAB-DEX=Sabouraud Dextrose

TSA=trypticase soy agar

Example 1

The following example examines the compatibility of different antimicrobial agents in cyanoacrylate compositions. In particular, the composition employed monomeric n-butyl cyanoacrylate containing 100 ppm sulfur dioxide and 20 weight percent of dioctyl phthalate absent the antimicrobial agent. In each case, either 5 weight percent, 10 weight percent or 20 weight percent of the antimicrobial agent, based on the total weight of the composition, was added thereto and the properties of the resulting composition

measured. The antimicrobial agents tested were elemental iodine, solid polyvinylpyrrolidone iodine, a 30% aqueous solution of polyvinylpyrrolidone iodine, silver nitrate, merbromin, tetracycline hydrate, and erythromycin (each of these antimicrobial agents were obtained from commercial sources).

The evaluation included assessing whether the antimicrobial agent was soluble or suspendable in the composition; whether the resulting composition cured upon contact with skin; whether curing provided for a polymeric film in situ on the skin; whether the polymeric film was flexible and durable. Solubility and suspendability were determined by conventional standards. The ability of the resulting composition to cure in situ upon application to skin was measured by applying the cyanoacrylate composition onto the upper arm of a male human subject and determining whether polymerization proceeded (up to 5 minutes) and, if so, the time required for polymerization. Film forming capabilities on the skin were assessed by visual evaluation. Durability was assessed by determining whether the film was retained on the skin surface for at least 24 hours and flexibility was measured by the ability of the film to be retained on the skin without cracking or peeling for at least 24 hours. The results of this evaluation are summarized in Table I below:

TABLE I

| Antimicrobial Agent | Conc. | Soluble | Curable | Film | | |
|------------------------------------|-------|----------------------------|-----------------------------------|--------|-------|------|
| | | | | Formed | Flex. | Dur. |
| elemental iodine (I ₂) | ~20% | partially | No (when tested for 5 minutes) | — | — | — |
| PVP-I ₂ solid | 10% | no suspension ² | Yes (30 seconds) | Yes | Yes | Yes |
| PVP-I ₂ solution | 10% | no, gelled ¹ | — | — | — | — |
| Silver nitrate | 5% | no, gelled ¹ | — | — | — | — |
| Merbromin | 5% | no, gelled ¹ | — | — | — | — |
| tetracycline hydrate | 5% | no, gelled ¹ | — | — | — | — |
| Erythromycin | 5% | no, gelled ¹ | — | — | — | — |

¹gel formation within 10 minutes of addition of the antimicrobial agent evidences premature polymerization of the cyanoacrylate. In such cases, the antimicrobial agent initiates polymerization.

²the mixture is readily resuspended with mild agitation. No gel formed over an 8 week period when stored at room temperature.

The above data demonstrates that of the antimicrobial agents tested, only polyvinylpyrrolidone iodine complex was compatible with the cyanoacrylate composition and, of the polyvinylpyrrolidone iodine complexes tested, only the solid form was compatible. Evidently, the solvent in the solution form of polyvinylpyrrolidone iodine complex initiated polymerization of the cyanoacrylate. Significantly, the suspension formed by the addition of solid polyvinylpyrrolidone iodine complex was curable in situ on human skin resulting in a flexible and durable polymeric film.

In addition to the above, tetracycline hydrochloride and hexachlorophene at 5 weight percent based on the total weight of the composition did not result in immediate polymerization of the cyanoacrylate composition but, rather, the composition polymerized over about a 48 hour period. Accordingly, when mixed immediately prior to use in the manner of this invention, these antimicrobial agents are compatible with the cyanoacrylate composition.

Example 2

The following example was conducted to ascertain the antimicrobial effect of a cyanoacrylate polymer film comprising PVP-iodine.

A. Preparation of the Inoculum

Specifically, the surfaces of two TSA plates, 100×15 mm, were inoculated with stock cultures (maintained on TSA slants) with the following microorganisms using a sterile inoculating loop: *Staphylococcus aureus* (ATCC No. 6538) and *Staphylococcus epidermidis* (ATCC No. 12228). The plates were incubated at 30° to 35° C. for 24 hours. The surfaces of two SAB-DEX agar plates were streaked with *Candida albicans* and incubated at 20–25° C. for 48 hours.

The cultures were harvested with sterile saline. Each culture suspension was collected in a sterile container and sufficient sterile saline was added to reduce the microbial count to obtain a working suspension of approximately 1×10⁸ CFU's per ml.

The specific microorganisms recited above were selected for inclusion herein because they are common human skin pathogens (bacteria and fungus).

B. Inoculation of Plates

Each of the three test microorganisms was used to inoculate individual TSA plates by streaking them with sterile cotton tip applicators saturated with the appropriate suspension. The plates were allowed to dry.

C. Inhibition Study

Films of polymerized n-butyl cyanoacrylate comprising 0%, 10%, 15%, 20% or 30% iodine polyvinylpyrrolidone complex were formed on 25 mm glass fiber filter disks by addition of the corresponding prepolymerized cyanoacrylate composition to the disks and subsequent polymerization in situ. The films were then cut into approximately 11 to 13 mm² pieces. The pieces were placed in the center of the appropriate inoculated TSA plates. An untreated filter disk was cut into half, and one-half was placed in the center of the appropriate inoculated TSA plate and the other one-half was placed in the center of non-inoculated TSA plates, to serve as a negative control. Two inoculated plates of each microorganism were also used as positive controls without the test article. These plates were then incubated for 3 days at 30° to 35° C. After incubation, the plates were removed and examined for any signs of microbial growth inhibition.

The results of this analysis are set forth in Tables I–III below. The sample sizes reported are the portion of the sample actually in contact with the agar. The sizes of the zone of inhibition include the diameters of the entire zone including the test article size.

TABLE I

| Results for <i>Staphylococcus aureus</i> | | |
|--|----------------------------------|---|
| SAMPLE: n-butyl cyanoacrylate comprising | SAMPLE SIZE ¹ (in mm) | ZONE OF INHIBITION ¹ (in mm) |
| 0% PVP-I ₂ | 12 | 12 |
| 10% PVP-I ₂ | 12 | 15 |
| 15% PVP-I ₂ | 12.5 | 14 |
| 20% PVP-I ₂ | 11.5 | 15.5 |
| 30% PVP-I ₂ | 12.5 | 20 |
| Untreated Filter Disk | 13 ² | 13 ² |
| Negative Control | 13 ² | 13 ² |
| Positive Control | n/a | 0 |

TABLE II

| Results for <i>Staphylococcus epidermis</i> | | |
|---|----------------------------------|---|
| SAMPLE: n-butyl cyanoacrylate comprising | SAMPLE SIZE ¹ (in mm) | ZONE OF INHIBITION ¹ (in mm) |
| 0% PVP-I ₂ | 12 | 12 |
| 10% PVP-I ₂ | 12.5 | 15 |
| 15% PVP-I ₂ | 12 | 15.5 |
| 20% PVP-I ₂ | 12.5 | 20.5 |
| 30% PVP-I ₂ | 13 | 27.5 |
| Untreated Filter Disk | 13 ² | 13 ² |
| Negative Control | 13 ² | 13 ² |
| Positive Control | n/a | 0 |

TABLE III

| Results for <i>Candida albicans</i> | | |
|--|----------------------------------|---|
| SAMPLE: n-butyl cyanoacrylate comprising | SAMPLE SIZE ¹ (in mm) | ZONE OF INHIBITION ¹ (in mm) |
| 0% PVP-I ₂ | 12 | 12 |
| 10% PVP-I ₂ | 12.5 | 18.5 |
| 15% PVP-I ₂ | 12.5 | 23 |
| 20% PVP-I ₂ | 12.5 | 20.5 |
| 30% PVP-I ₂ | 13 | 29.5 |
| Untreated Filter Disk | 13 ² | 13 ² |
| Negative Control | 13 ² | 13 ² |
| Positive Control | n/a | 0 |

¹average of two runs

²single run only

The above data demonstrates that the compositions of this invention produce a polymeric cyanoacrylate film which have antimicrobial activity. Based on these results, it is expected that these compositions would be antimicrobial when formed in situ on mammalian skin surfaces.

What is claimed is:

1. A kit of parts which comprises:

(a) a first container comprising therein a polymerizable cyanoacrylate ester which in monomeric form is represented by the formula:

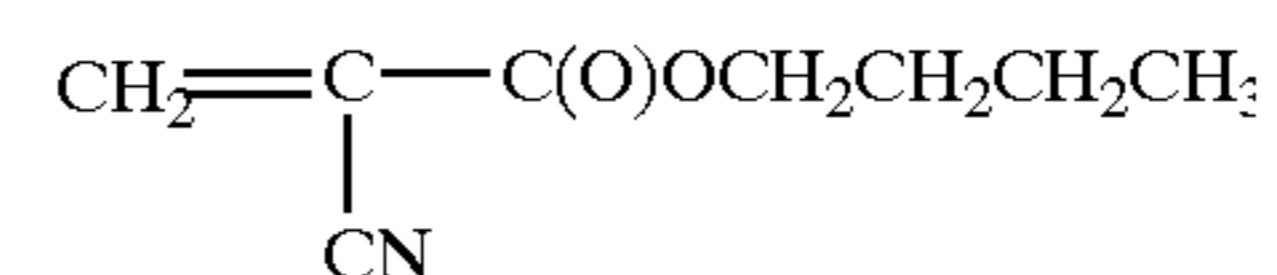

and

(b) a second container comprising therein an antimicrobially effective amount of a compatible antimicrobial agent.

2. The kit according to claim 1 wherein said antimicrobial agent is selected from the group consisting of PVP-I₂, hexachlorophene and tetracycline hydrochloride.

3. The kit according to claim 1 which further comprises a biocompatible plasticizer.

4. The kit according to claim 1 which further comprises a polymerization inhibitor.

5. A kit of parts according to claim 1 further comprising an applicator means for applying the composition onto mammalian skin.

6. A kit of parts according to claim 5 wherein one of the containers and applicator means are combined into a single article.

7. A kit of parts according to claim 5 herein the containers and applicator means are separate articles.