



US006473577B1

(12) **United States Patent**
Higeta et al.

(10) **Patent No.:** **US 6,473,577 B1**
(45) **Date of Patent:** **Oct. 29, 2002**

- (54) **PROCESS CARTRIDGE
REMANUFACTURING METHOD**
- (75) Inventors: **Akira Higeta**, Funabashi; **Yoshiyuki Kakumi**, Tuchiura, both of (JP)
- (73) Assignee: **Canon Kabushiki Kaisha**, Tokyo (JP)
- (*) Notice: Subject to any disclaimer, the term of this patent is extended or adjusted under 35 U.S.C. 154(b) by 0 days.

EP	0 634 707 A2	1/1995
JP	5-323693	7/1993
JP	07-219344	* 8/1995
JP	7-295376	11/1995

OTHER PUBLICATIONS

Patent Abstracts of Japan, vol. 018, No. 149 (P-1708), Mar. 11, 1994 (JP-05-323693).

* cited by examiner

Primary Examiner—Sophia S. Chen

(74) *Attorney, Agent, or Firm*—Fitzpatrick, Cella, Harper & Scinto

- (21) Appl. No.: **09/696,308**
- (22) Filed: **Oct. 26, 2000**
- (30) **Foreign Application Priority Data**
Oct. 29, 1999 (JP) 11-309618
- (51) **Int. Cl.⁷** **G03G 15/00**
- (52) **U.S. Cl.** **399/109**; 399/103; 399/111
- (58) **Field of Search** 399/109, 102,
399/103, 105, 106, 111, 113

(57) **ABSTRACT**

A remanufacturing method of remanufacturing a process cartridge includes (a) a step of preparing a used process cartridge which comprises a toner developing container, a cleaning container and pins for coupling the toner developing container and the cleaning container at opposite longitudinal ends of the process cartridge; the toner developing container including a toner accommodating portion, a toner supply opening, a developing roller and a developing blade; the cleaning container including an electrophotographic photosensitive drum; (b) a container separating step of separating the process cartridge into the toner developing container and the cleaning container by disengaging the pins from the process cartridge; (c) a blade seal mounting step of mounting a blade seal between a blade mounting plate and an outside of a toner developing frame to seal a gap between the blade mounting plate and the toner developing frame; (h) a toner refilling step of refilling the toner into the toner accommodating portion of the toner developing container having the blade seal; and (i) a container coupling step of coupling the toner developing container having the blade seal with the cleaning container by engaging the pins into them.

- (56) **References Cited**
- U.S. PATENT DOCUMENTS**
- 5,331,373 A 7/1994 Nomura et al. 399/111
- 5,452,056 A 9/1995 Nomura et al. 399/111
- 5,485,249 A 1/1996 Higeta et al. 399/105
- 5,585,889 A 12/1996 Shishido et al. 399/113
- 5,592,268 A * 1/1997 Uehara et al. 399/276
- 5,740,499 A 4/1998 Higeta et al. 399/105
- 5,809,374 A 9/1998 Tsuda et al. 399/111
- 5,870,654 A * 2/1999 Sato et al. 399/109
- 5,890,036 A * 3/1999 Karakama et al. 399/111 X
- 6,101,348 A 8/2000 Nonaka et al. 399/103
- 6,212,343 B1 * 4/2001 Hosokawa et al. 399/102

FOREIGN PATENT DOCUMENTS

EP 0 485 271 A2 5/1992

15 Claims, 45 Drawing Sheets

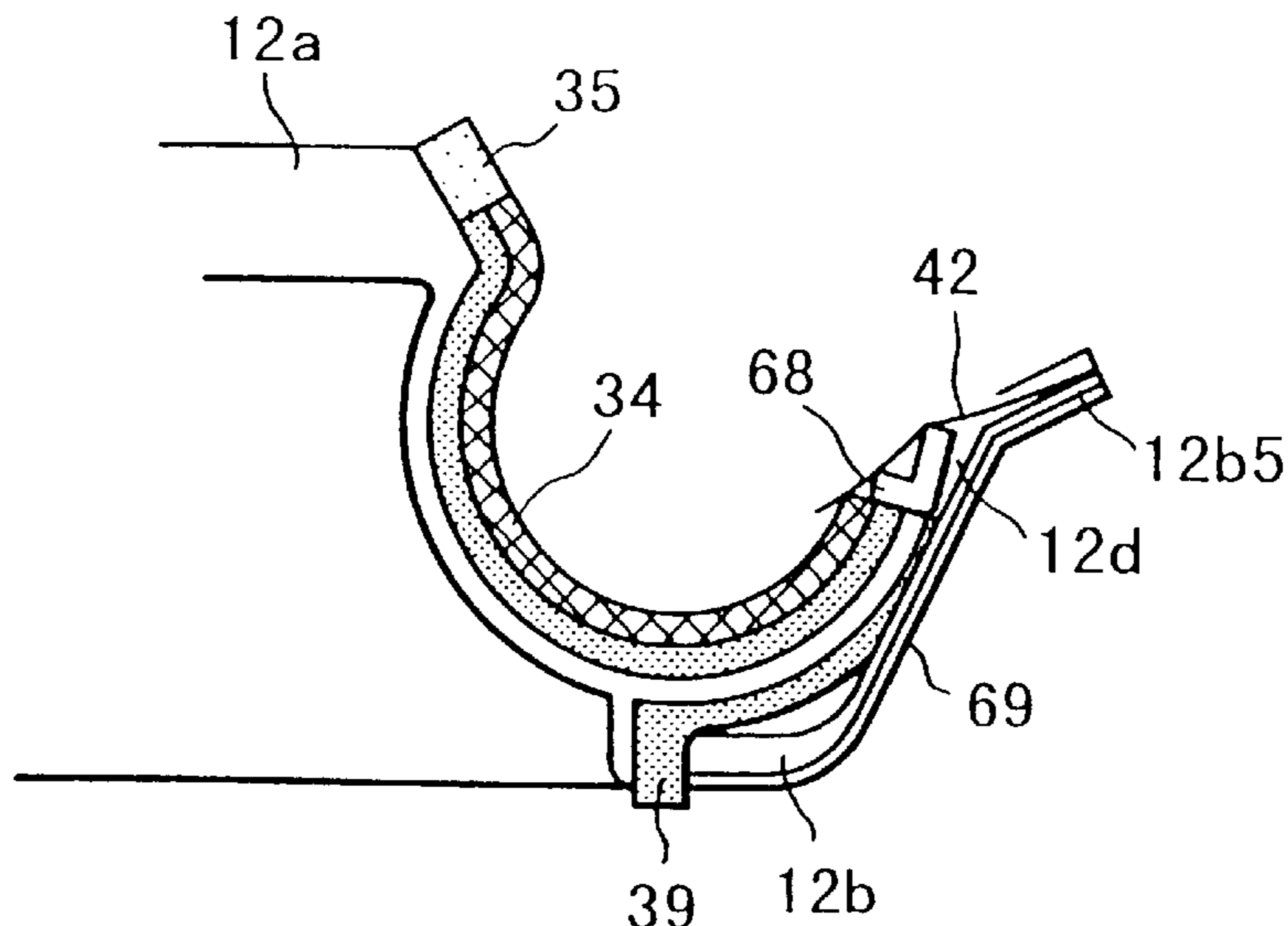

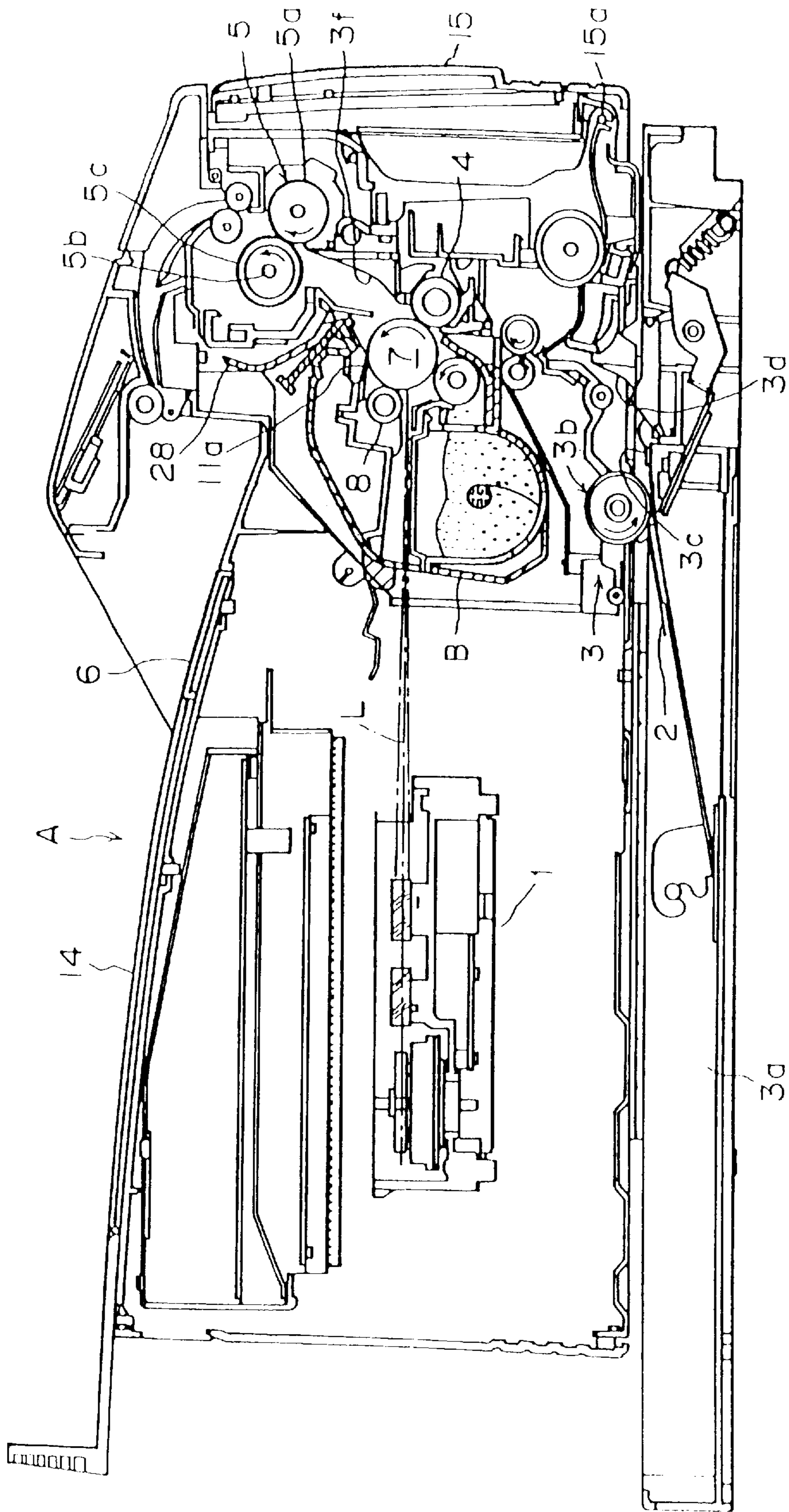

FIG. 1

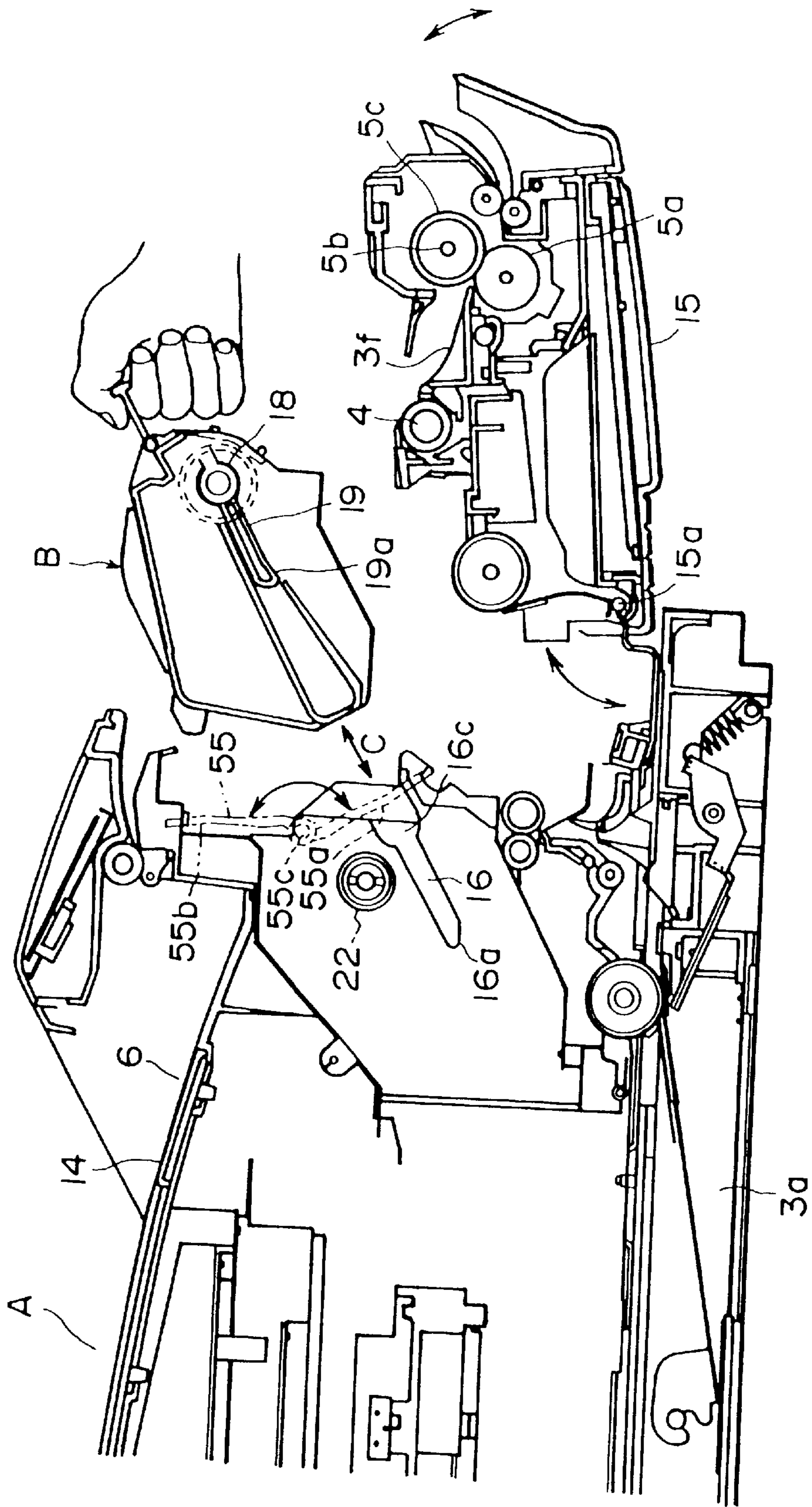

FIG. 2

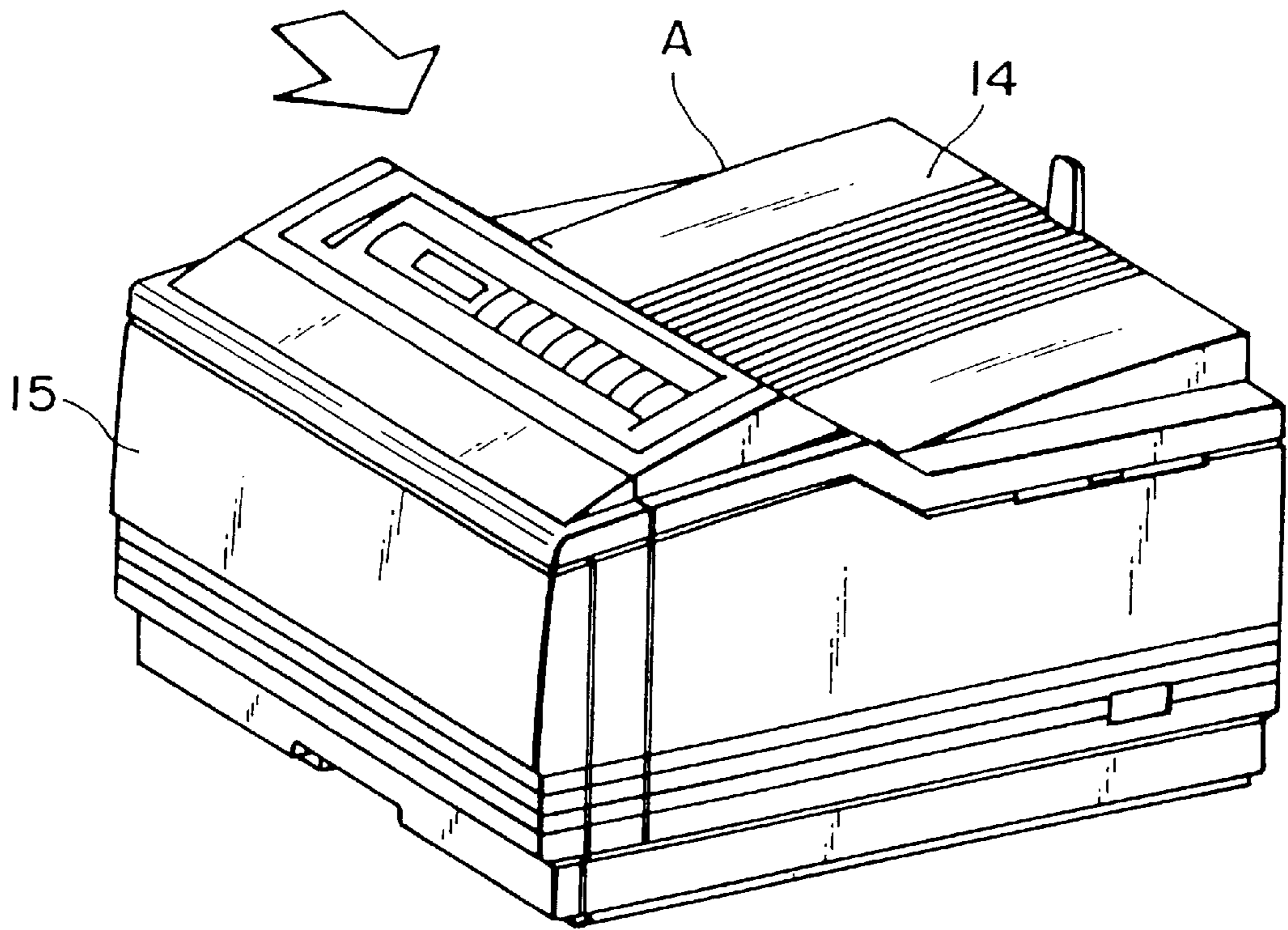

FIG. 3

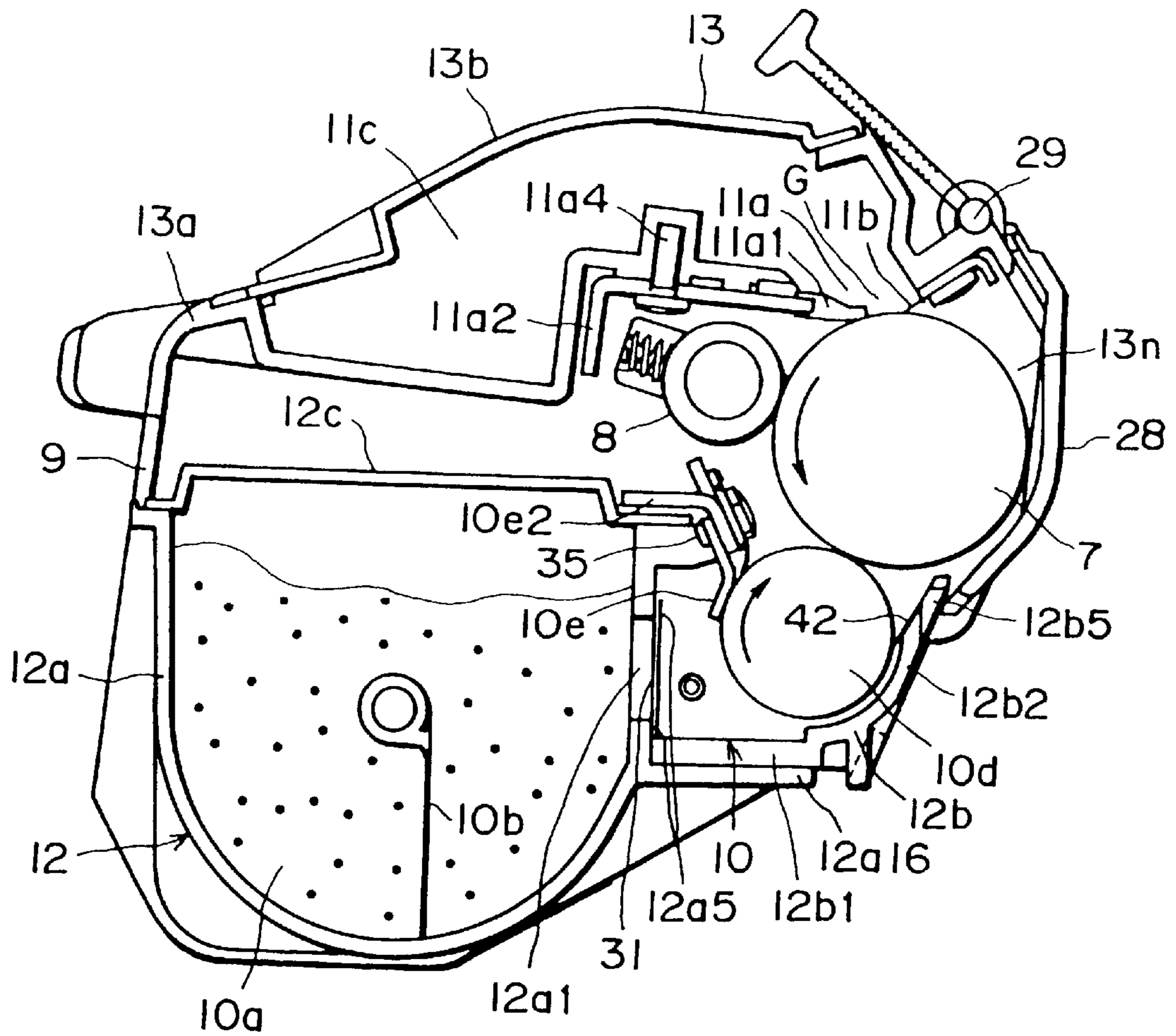

FIG. 4

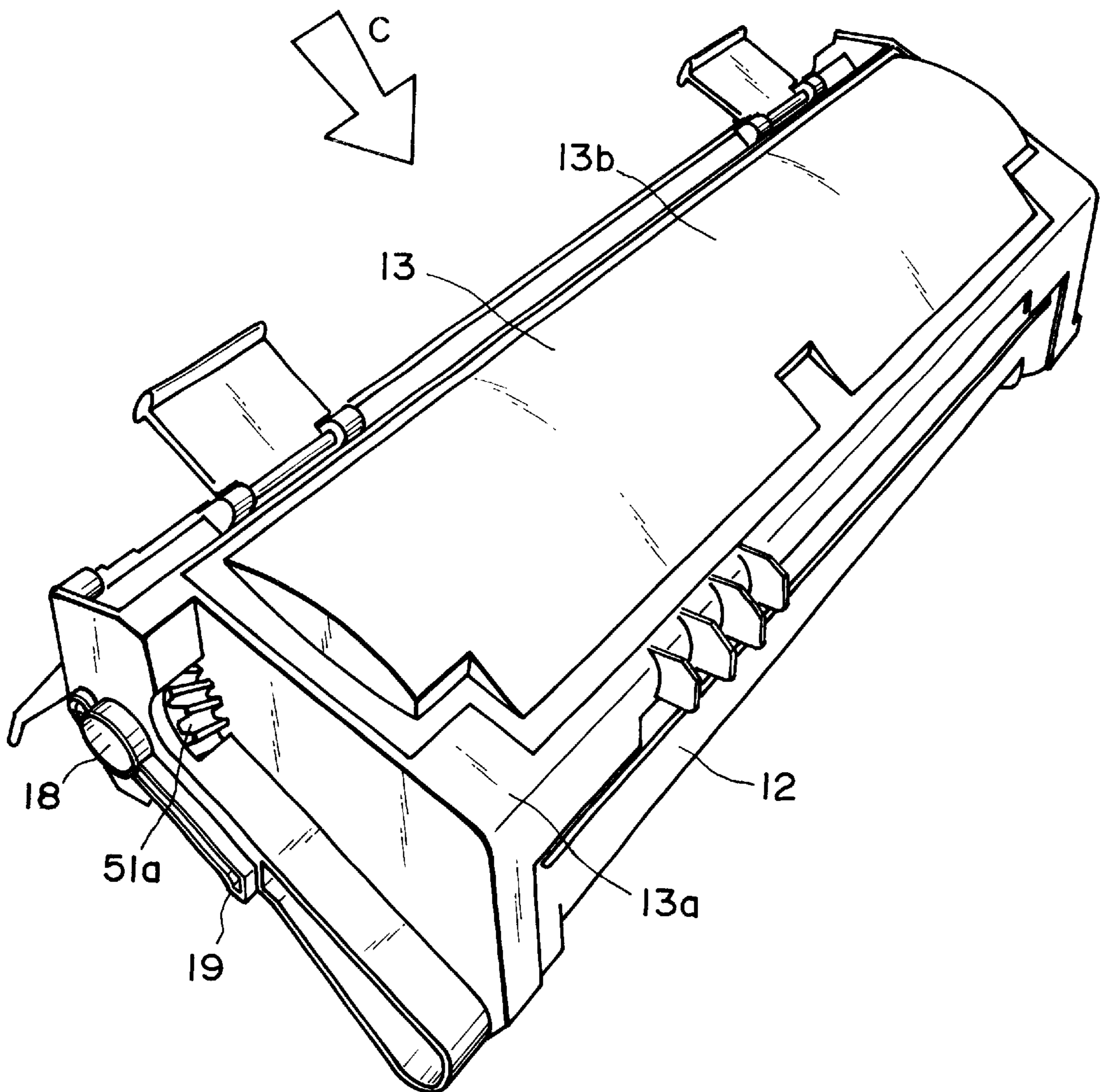

FIG. 5

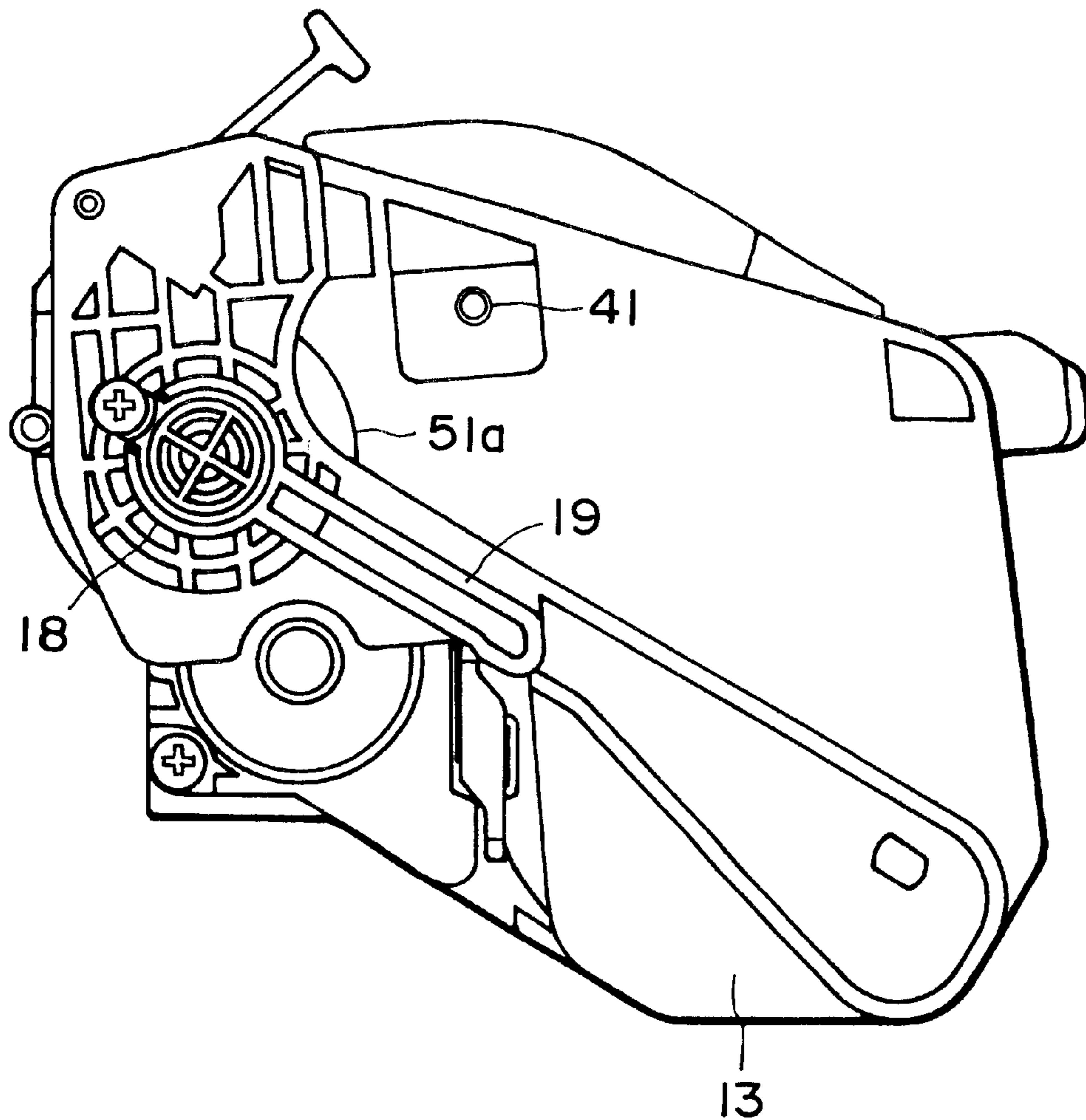

FIG. 6

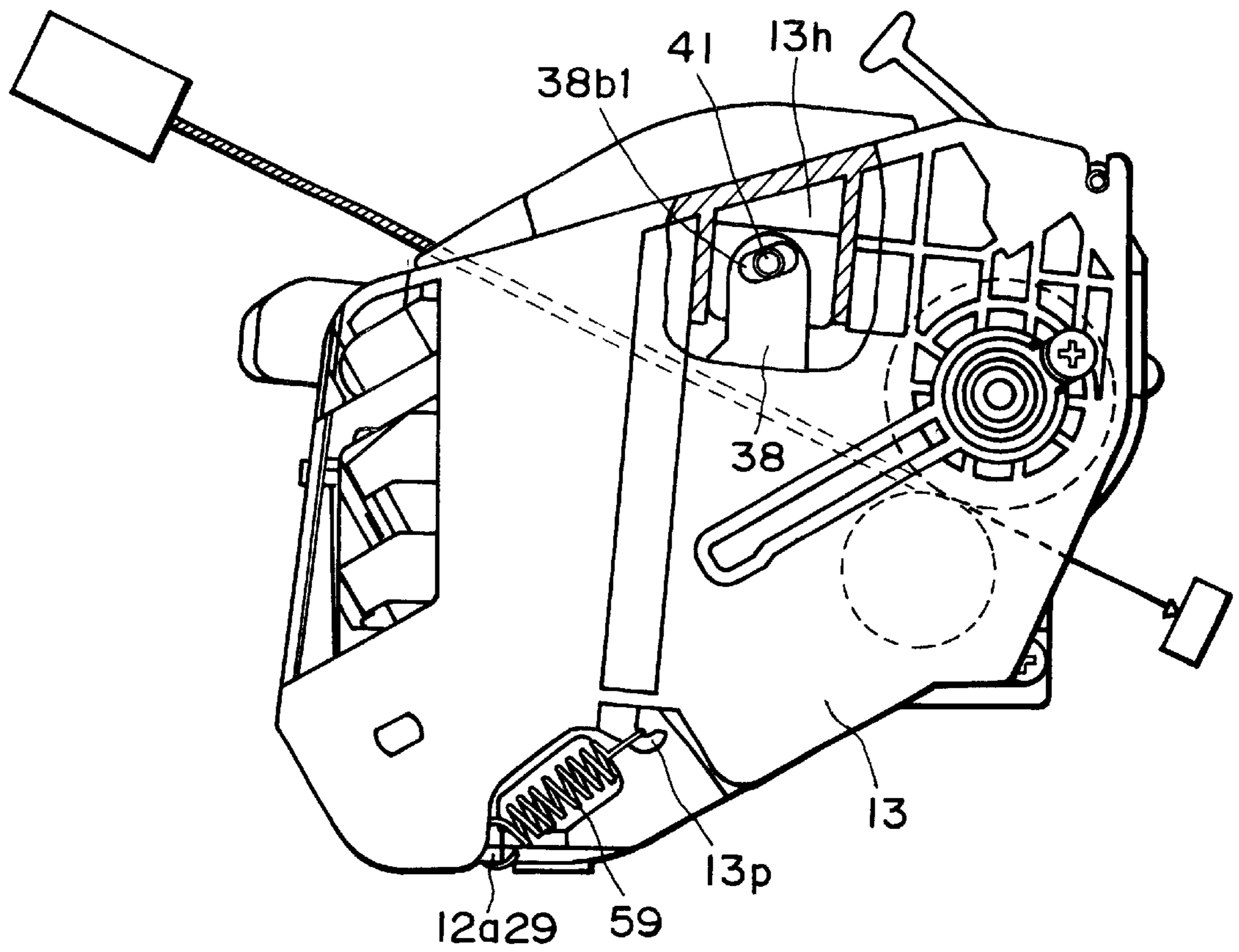

FIG. 7

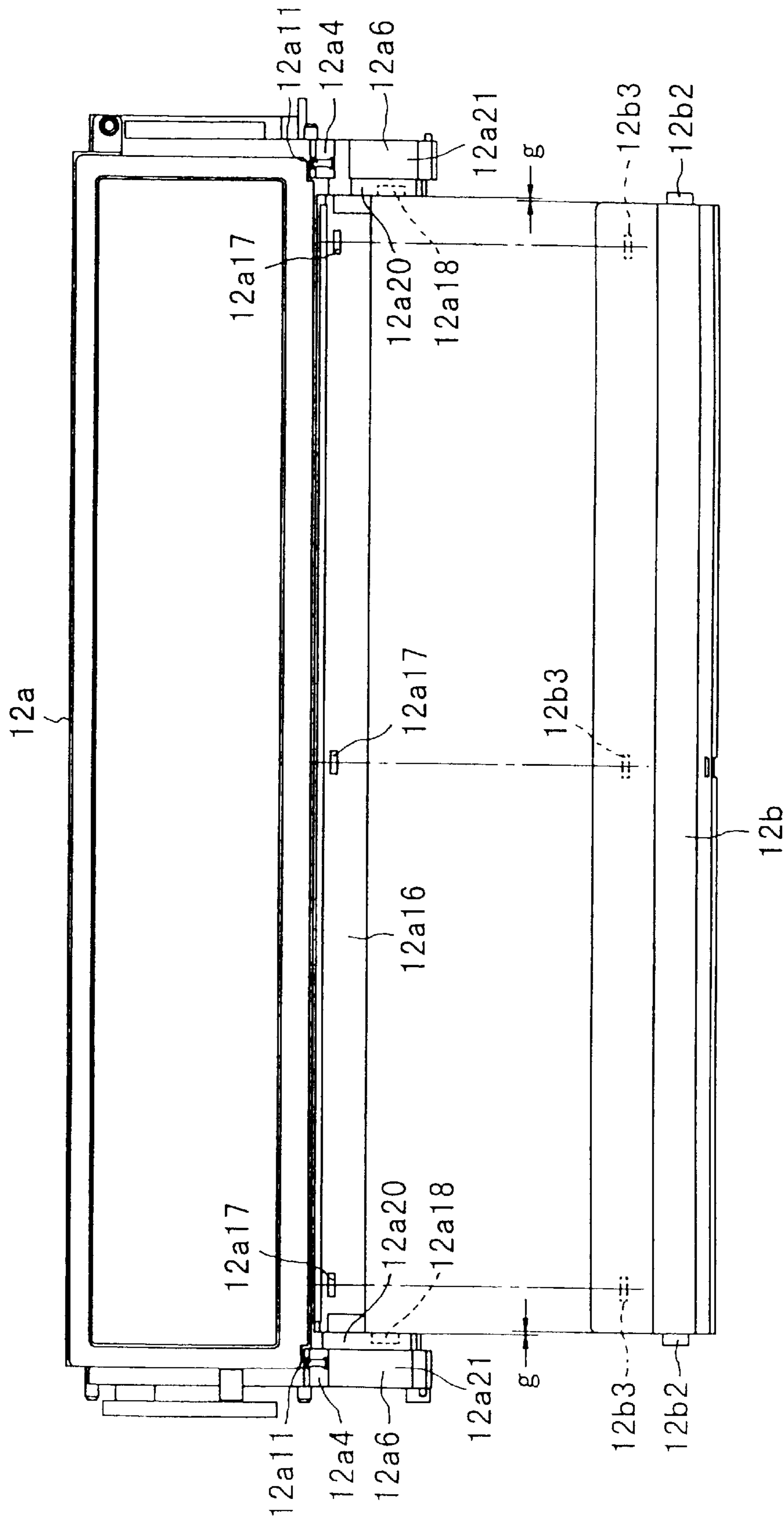

FIG. 8

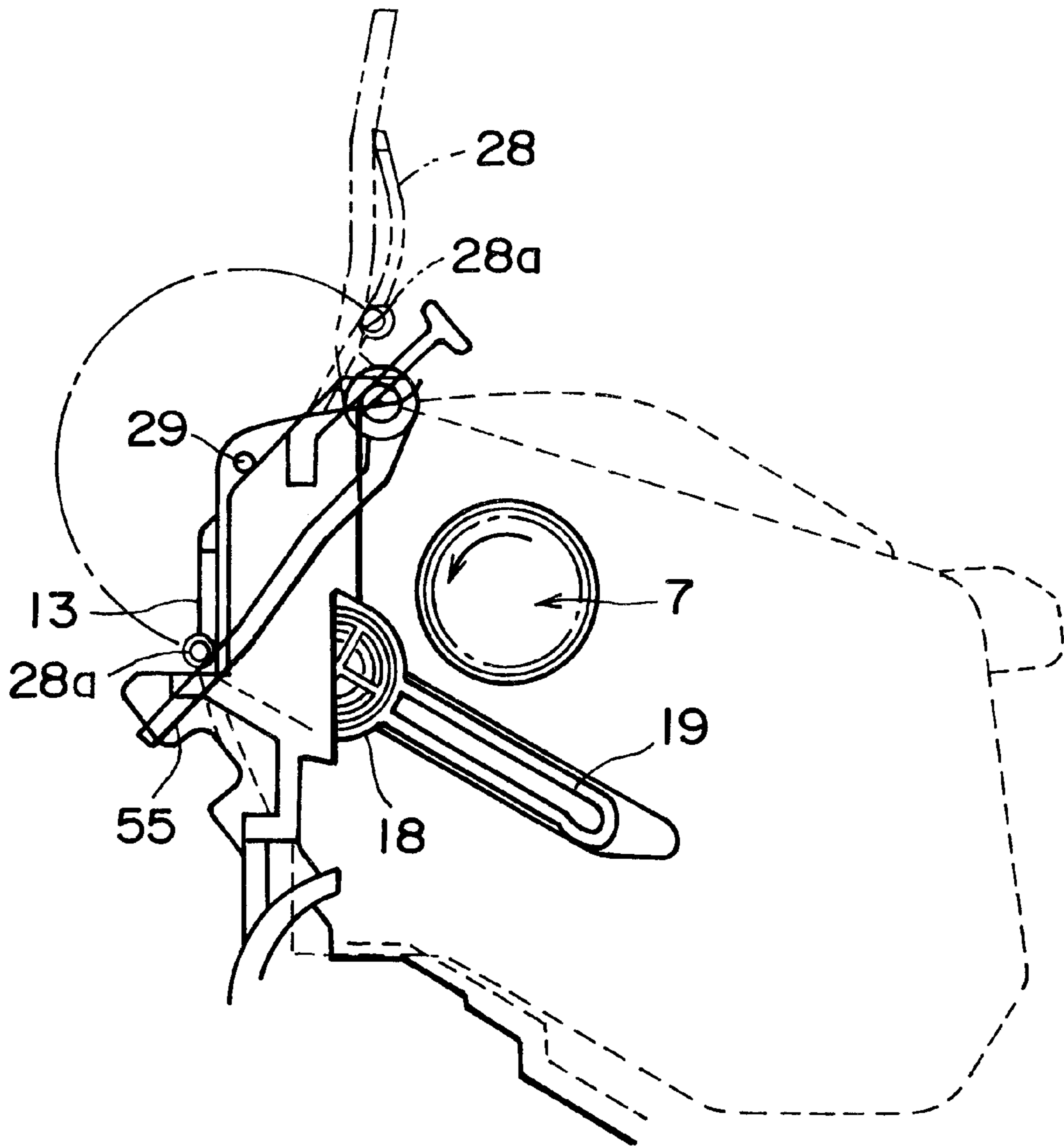

FIG. 9

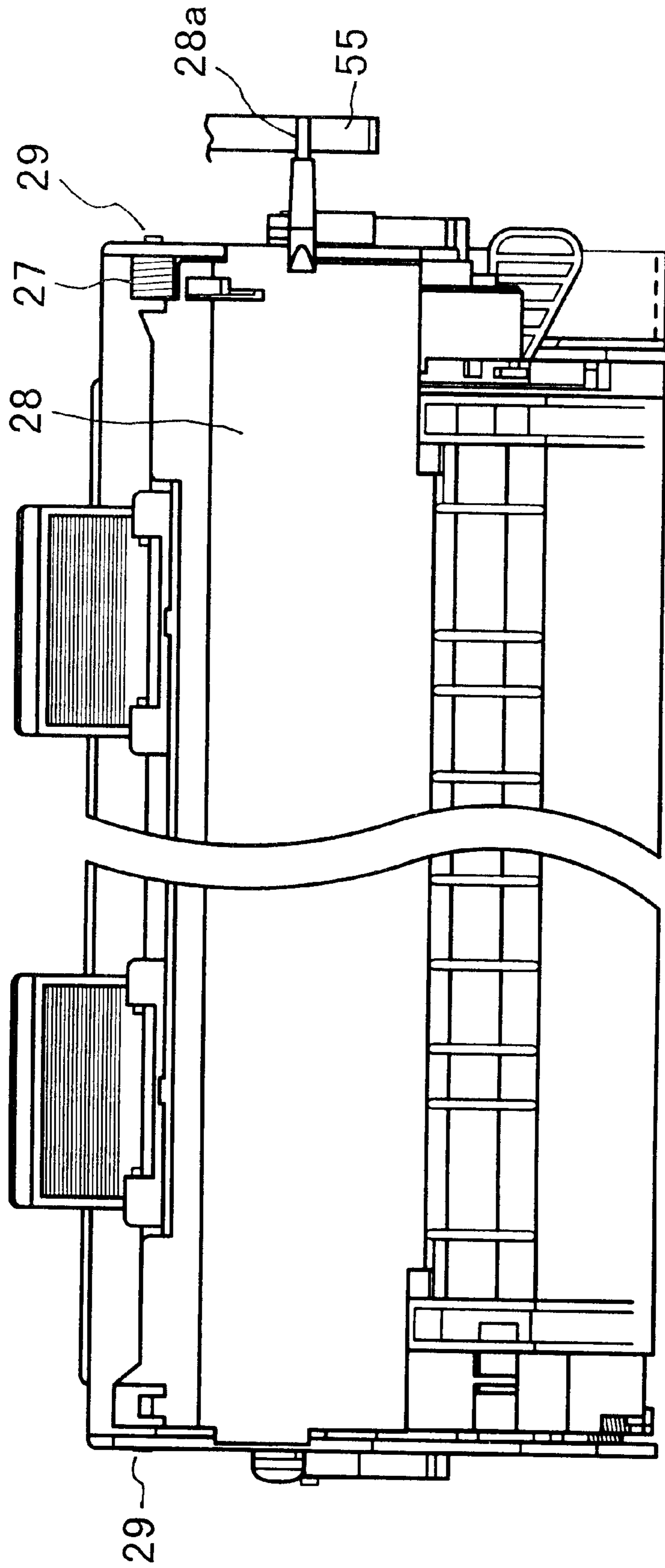

FIG. 10

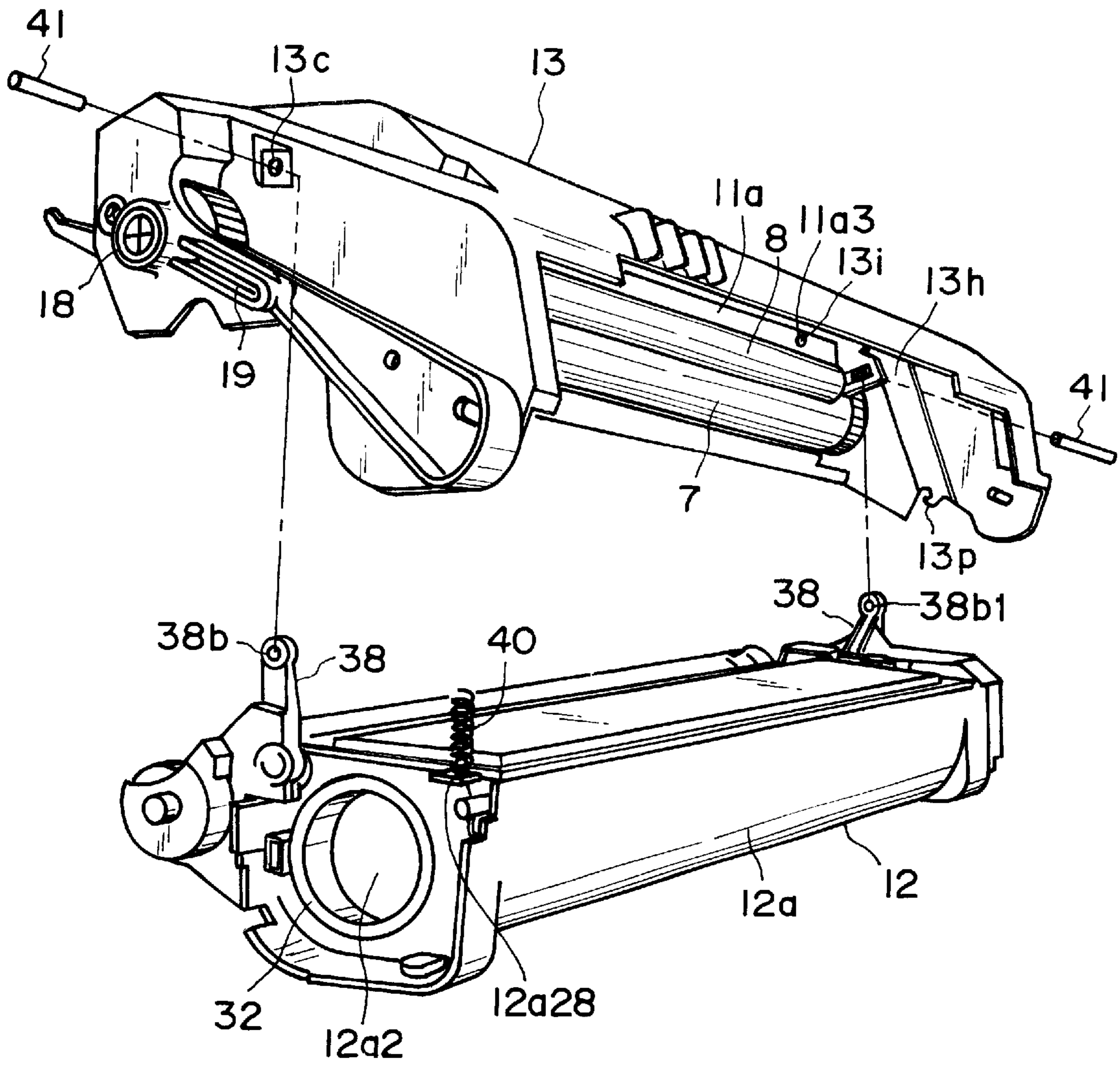

FIG. 11

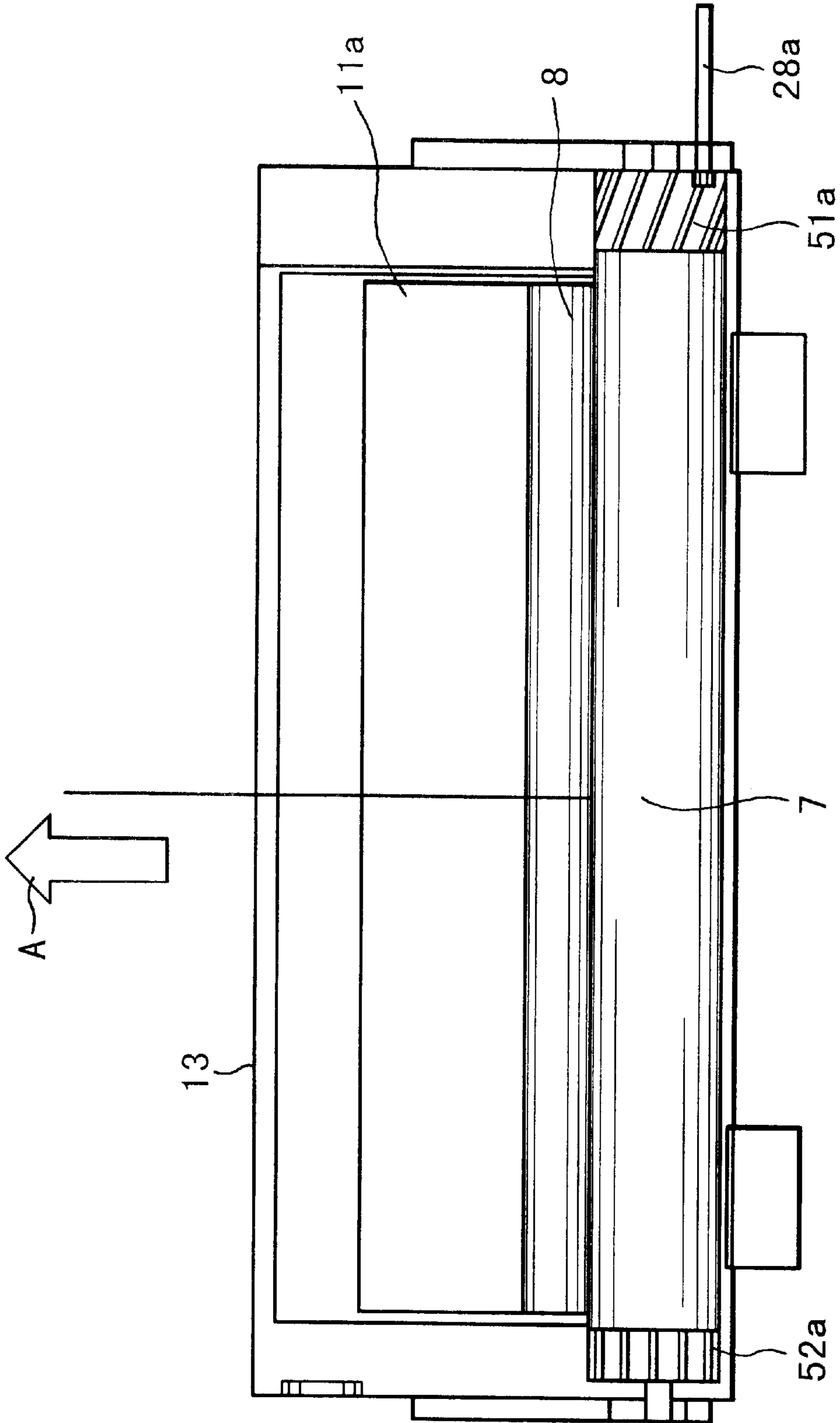

FIG. 12

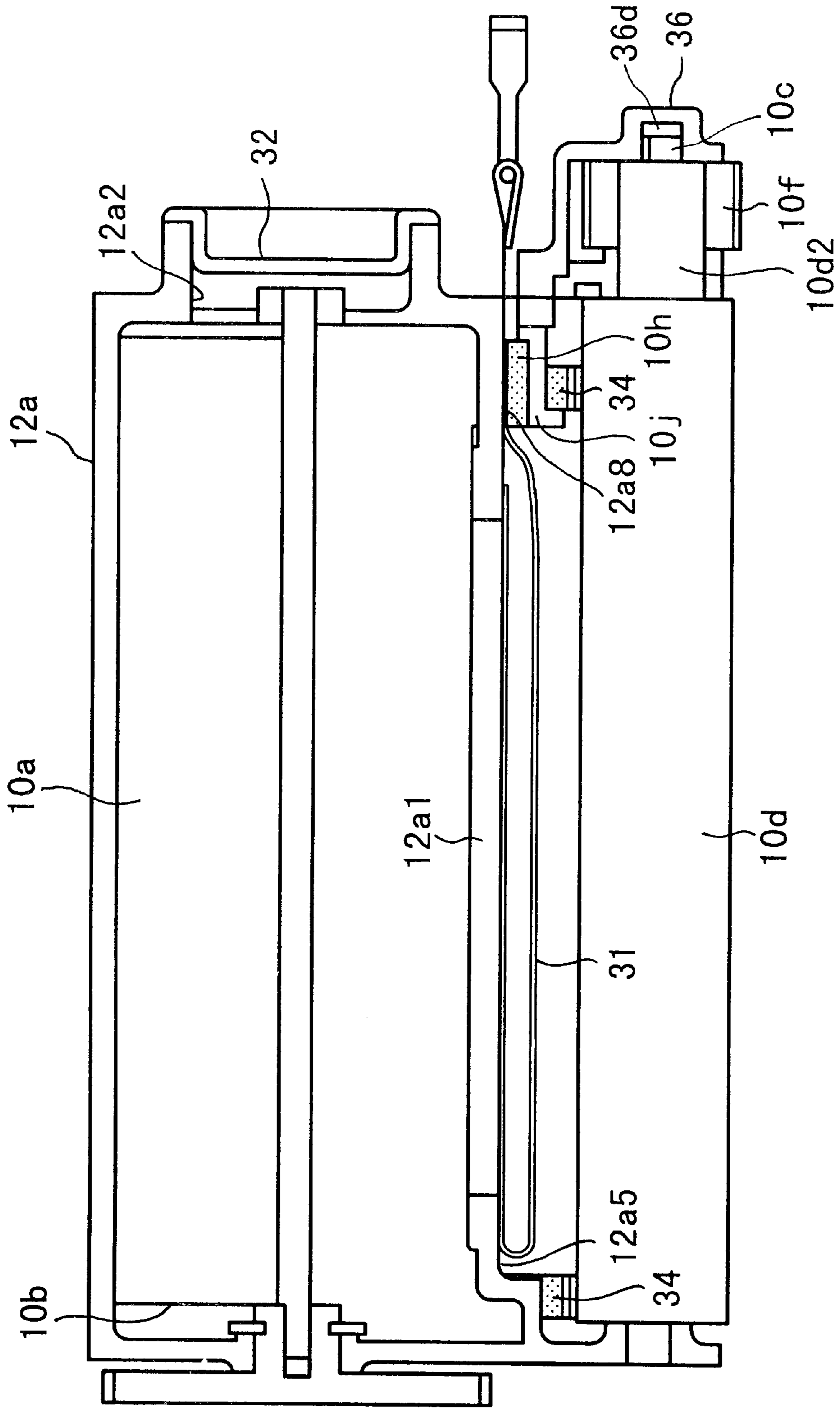

FIG. 13

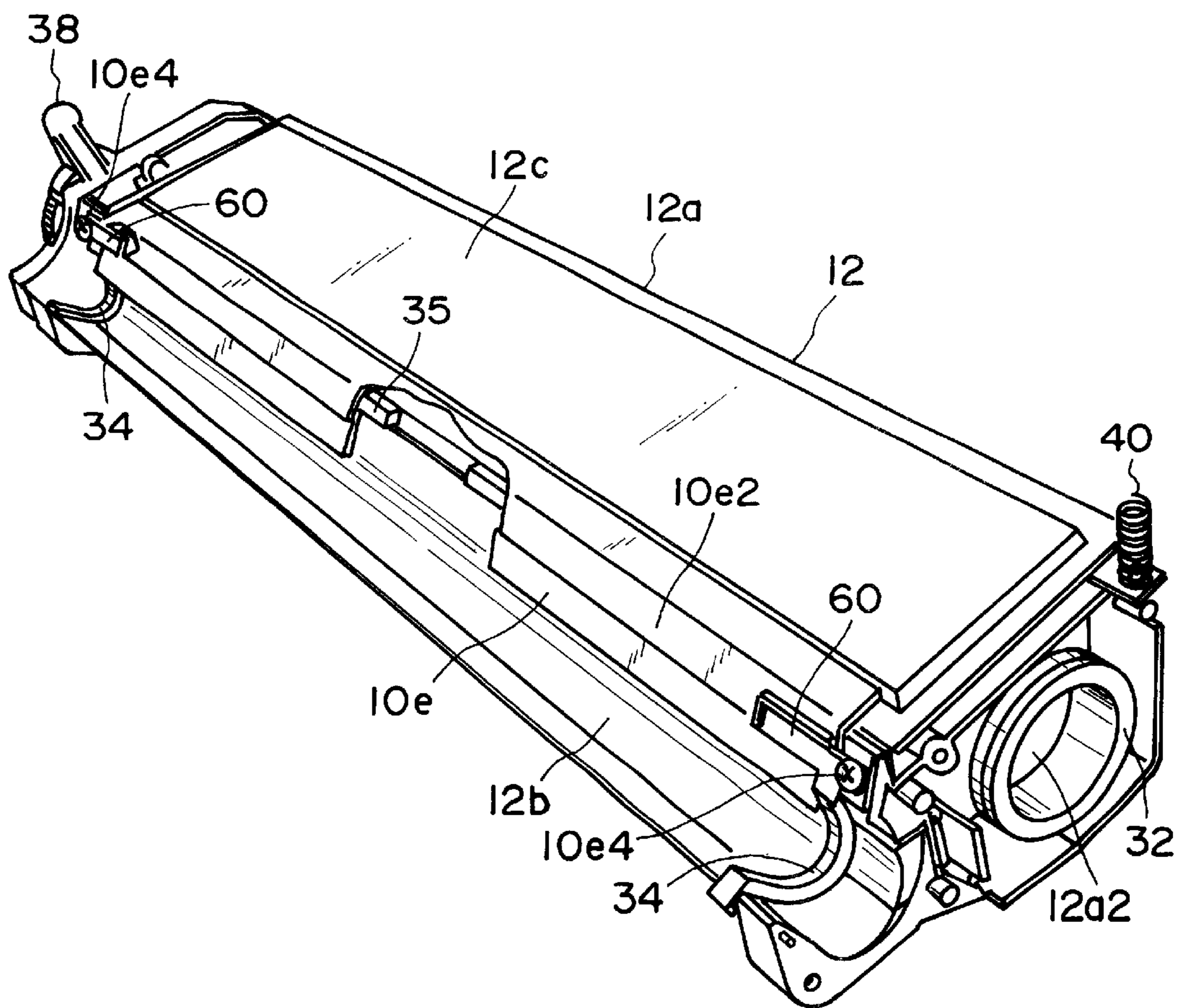

FIG. 14

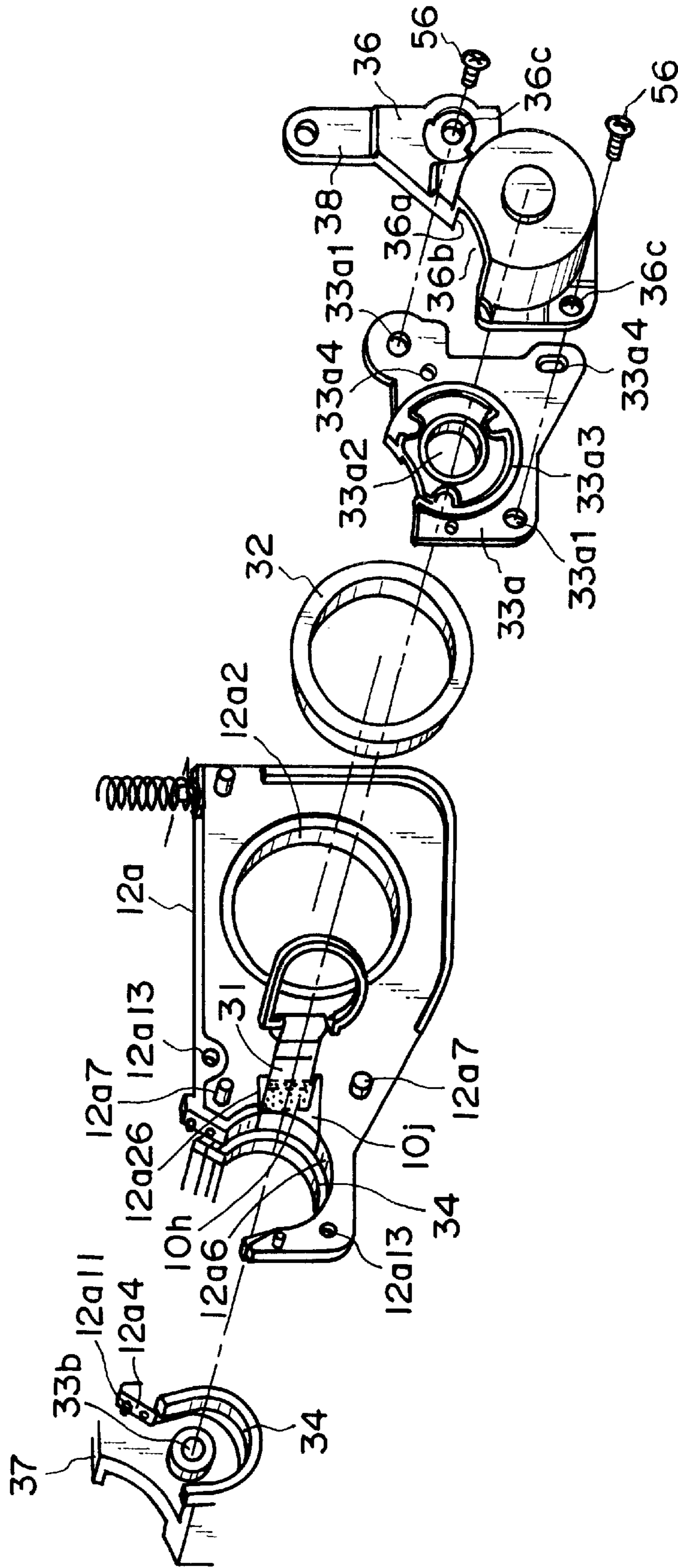

FIG. 15

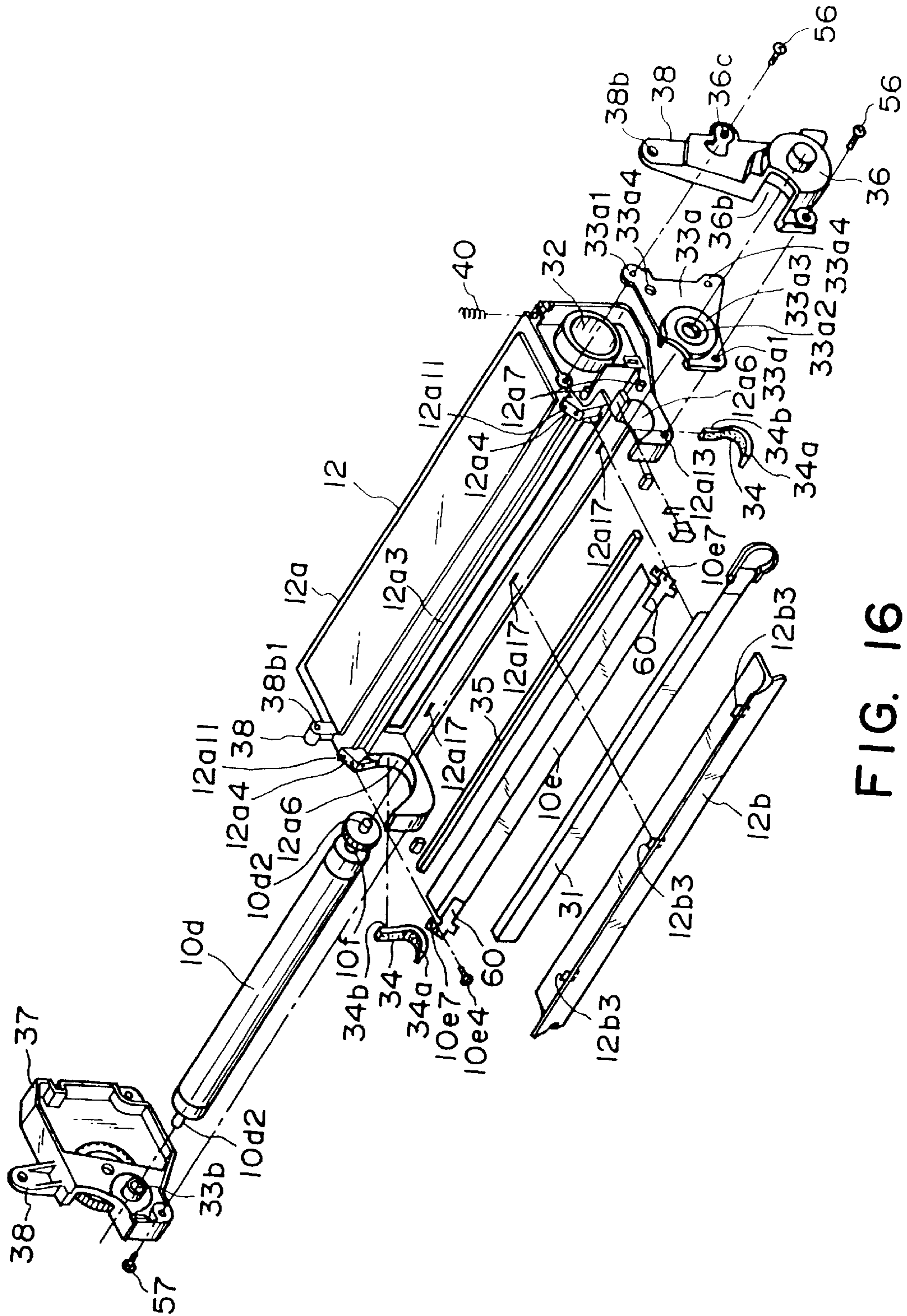

FIG. 16

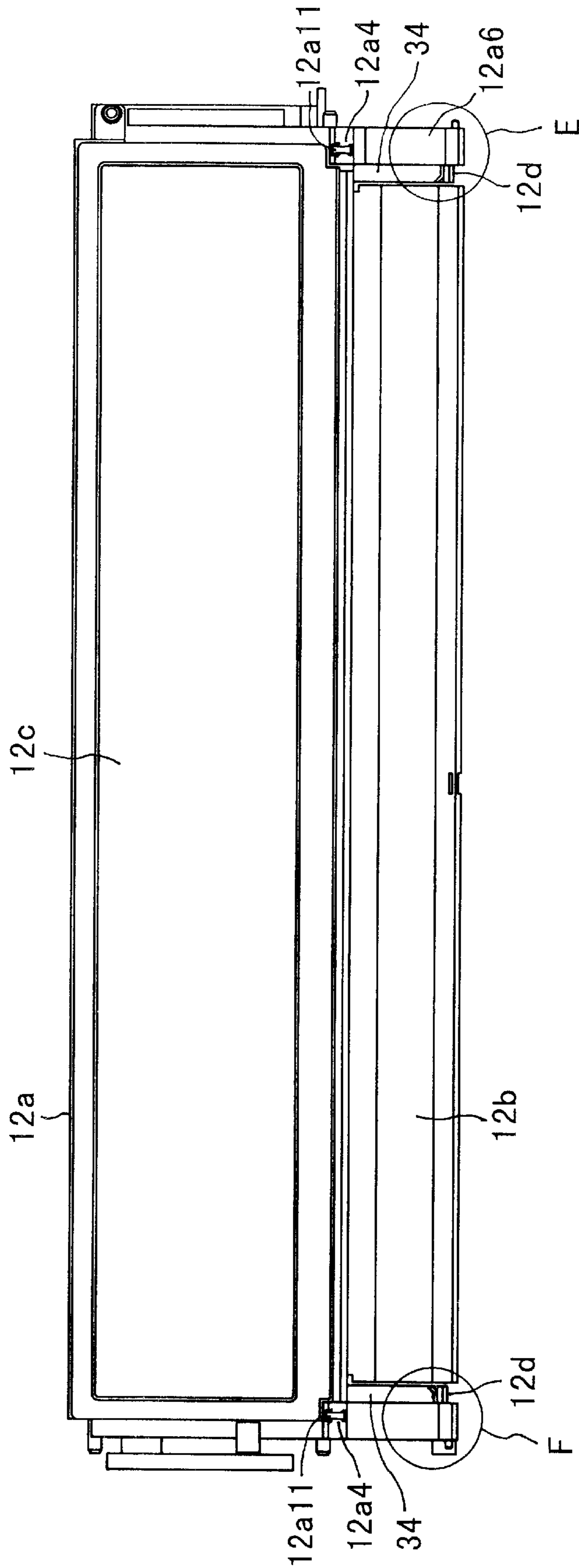

FIG. 17

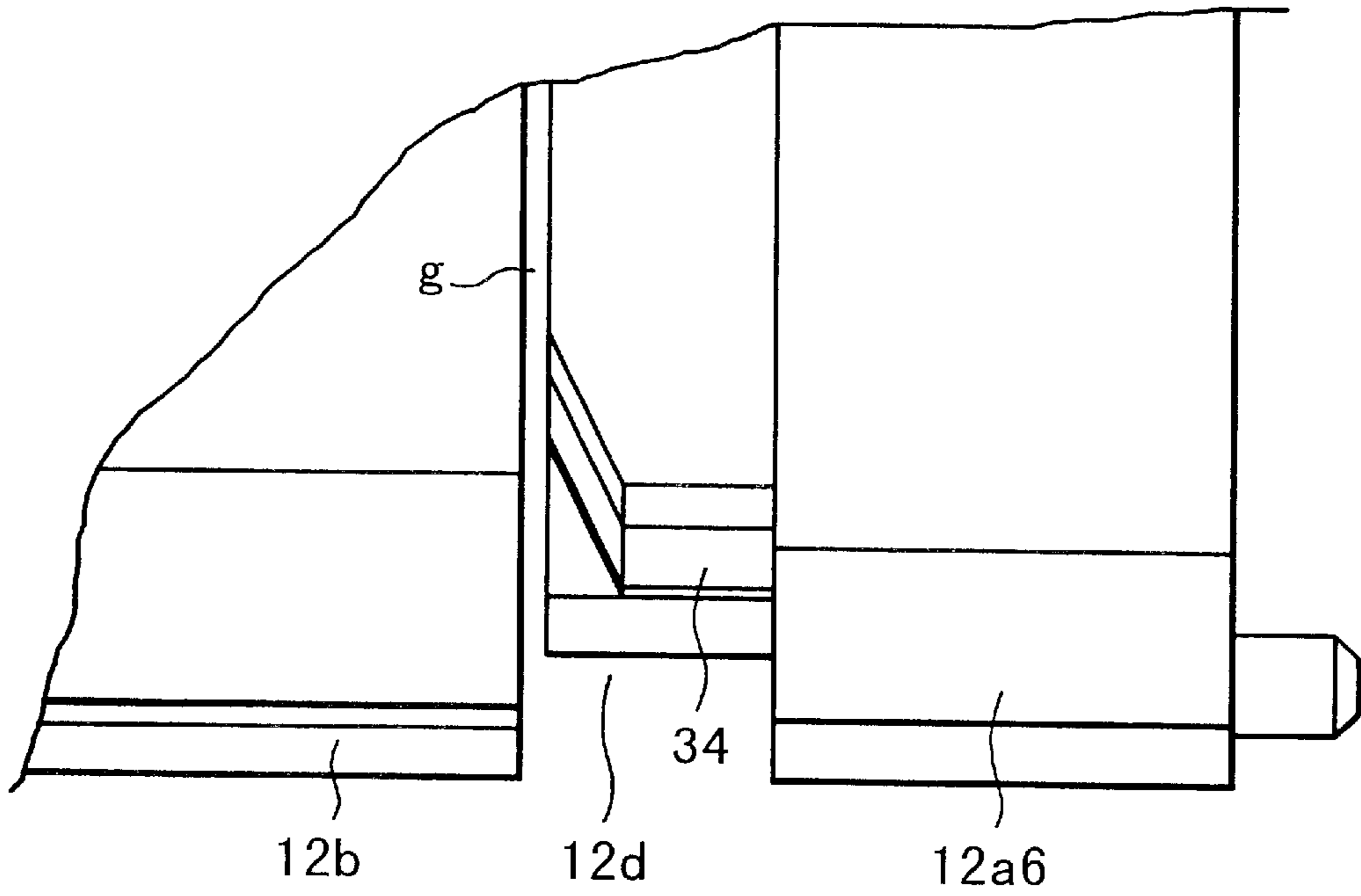

FIG. 18

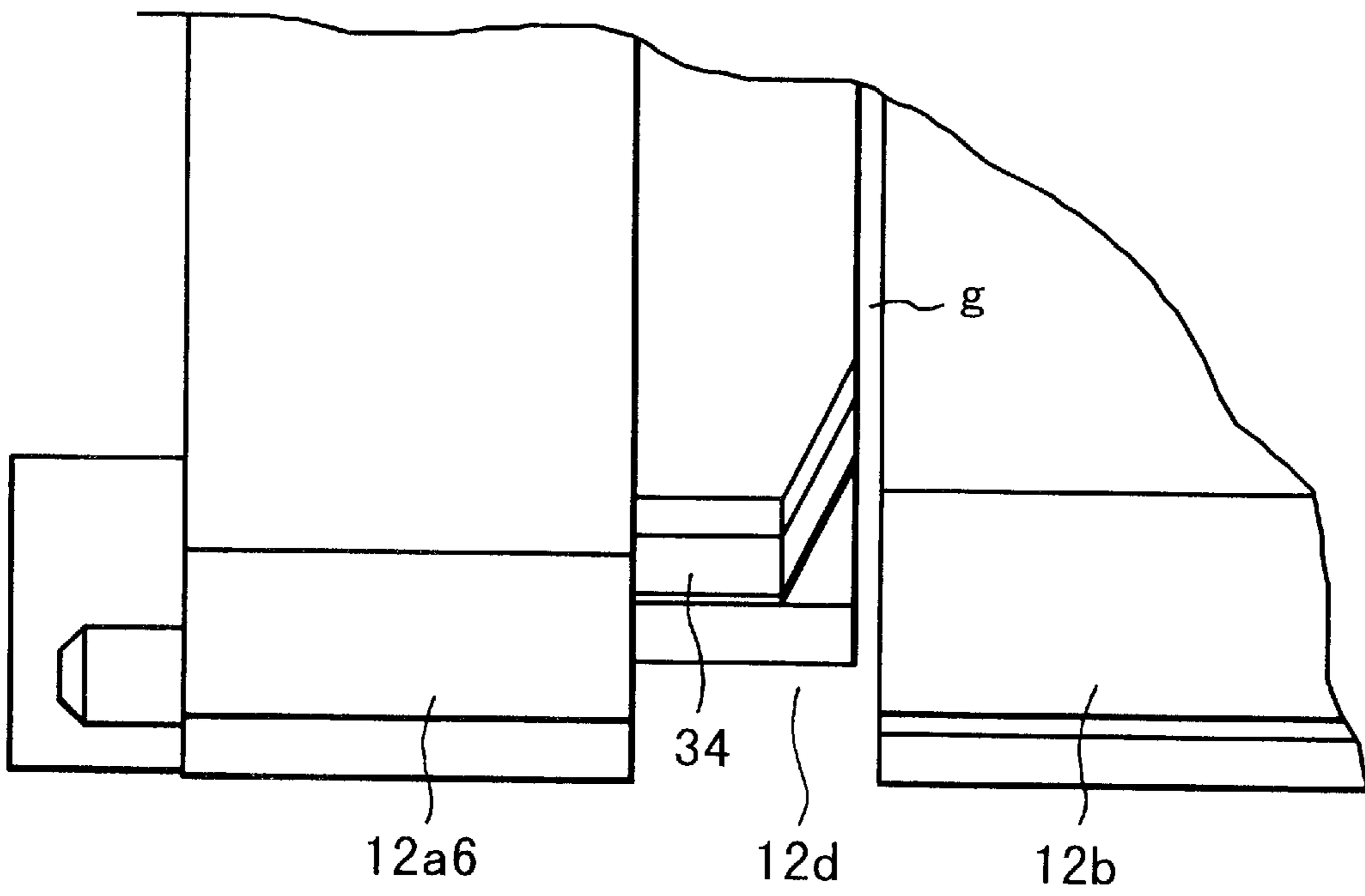

FIG. 19

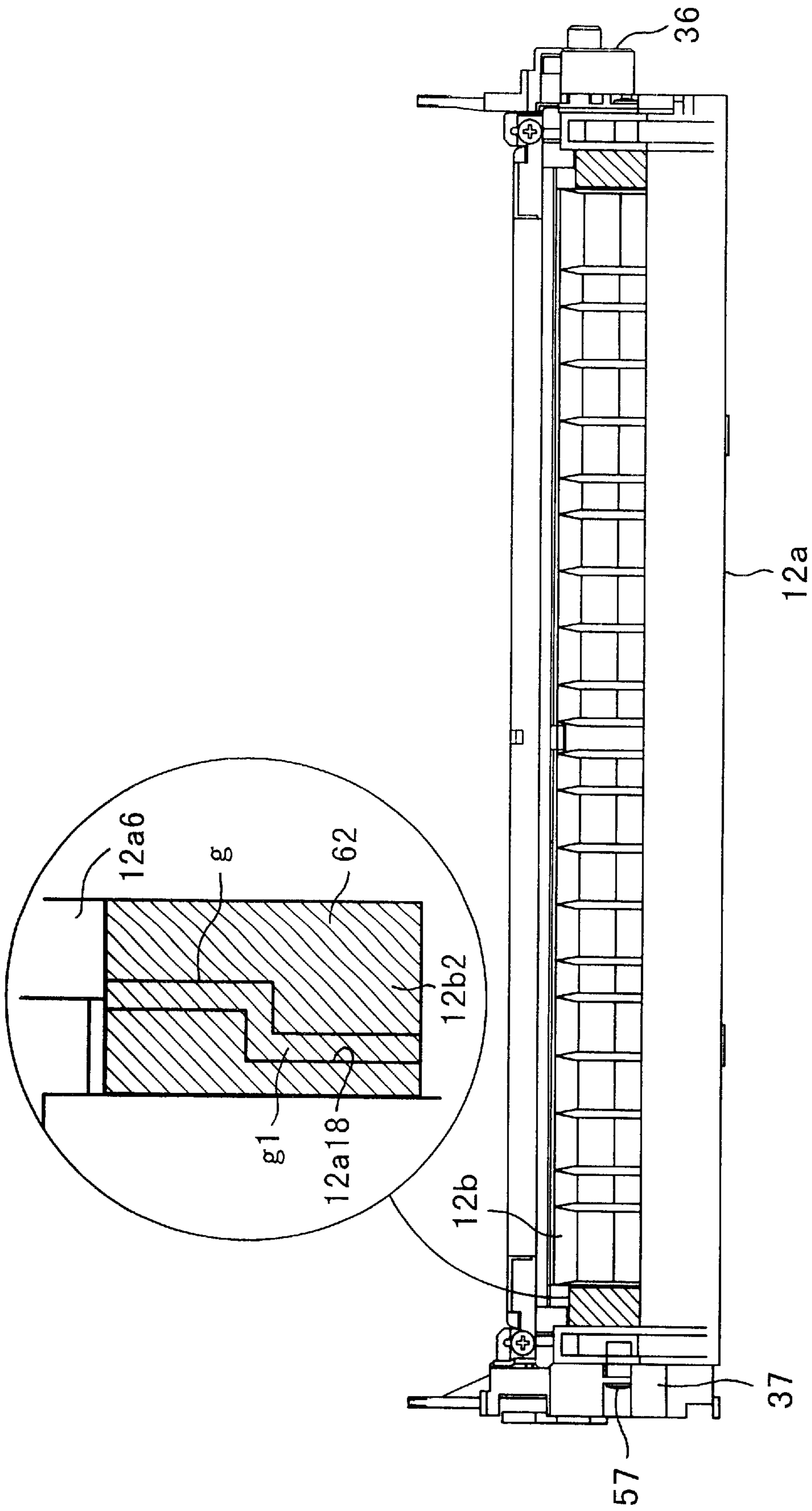

FIG. 20

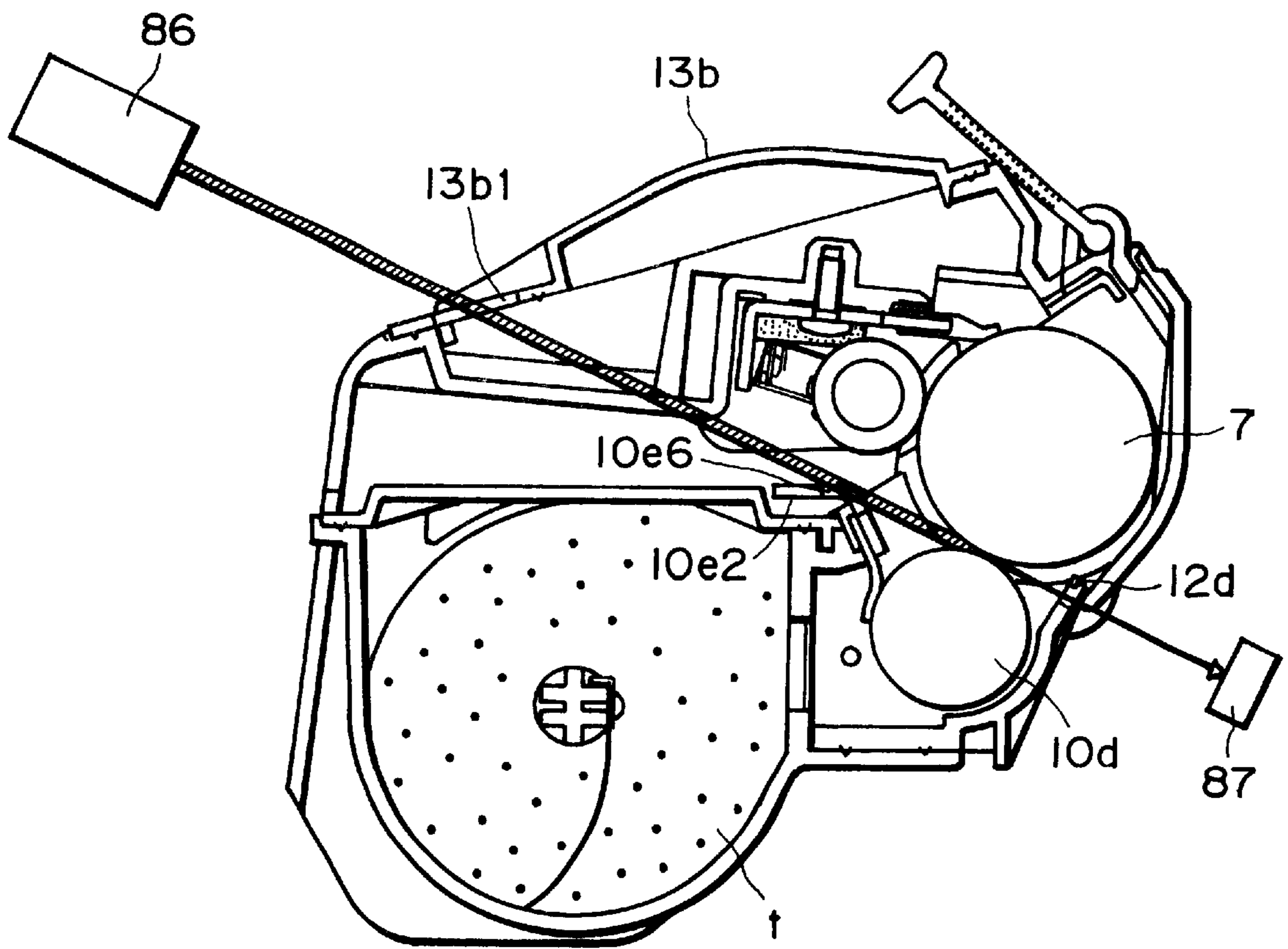

FIG. 21

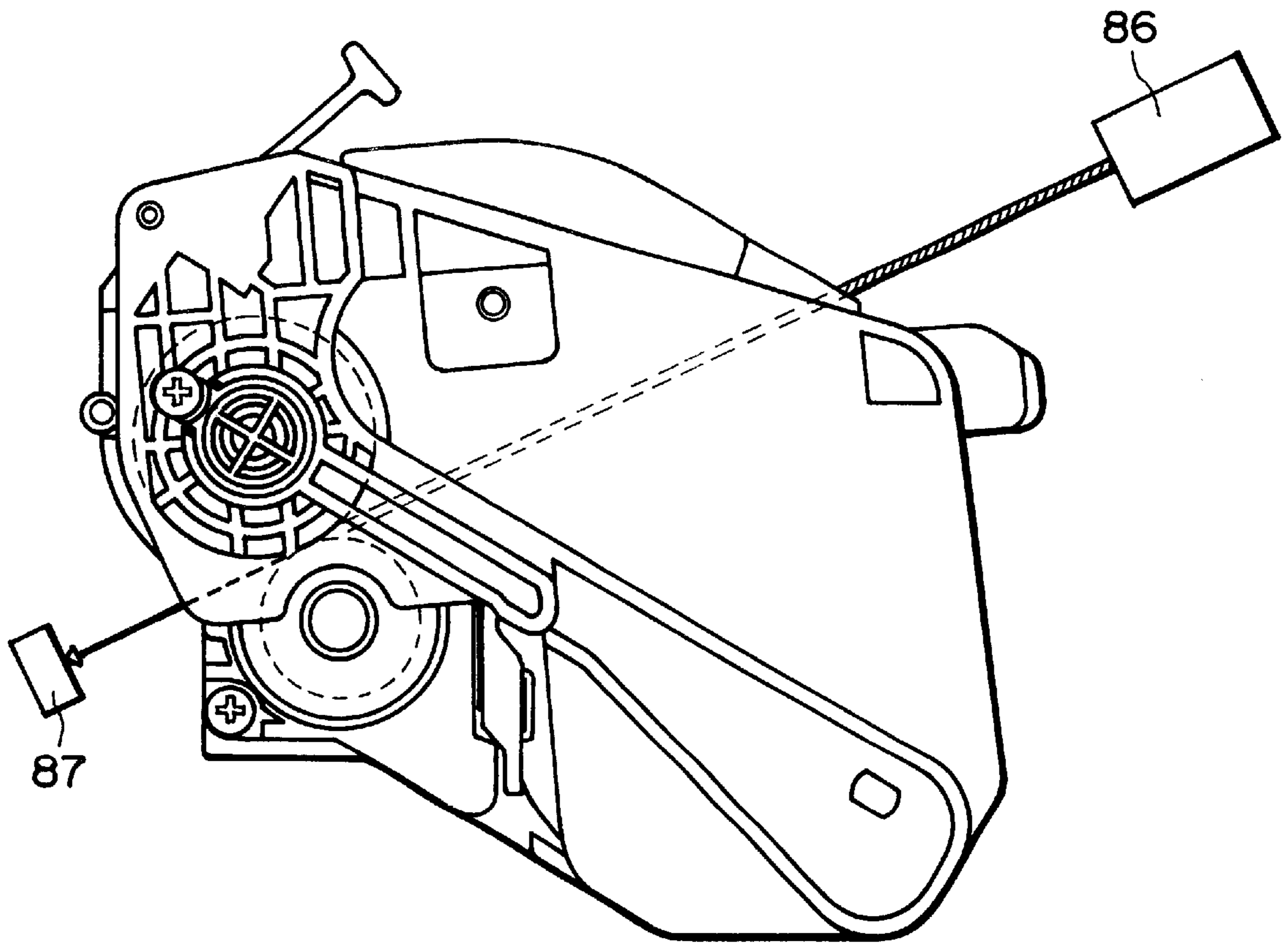

FIG. 22

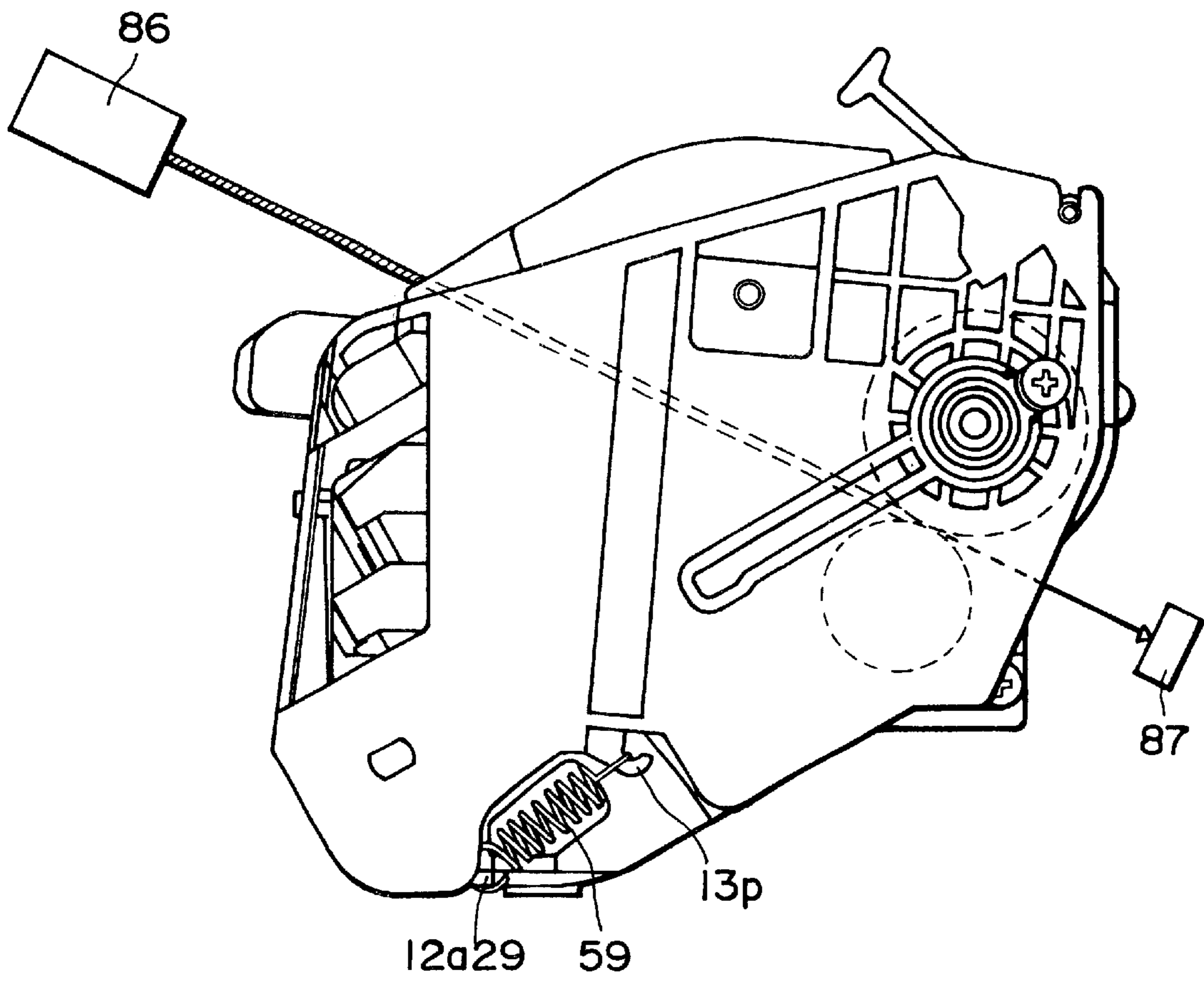

FIG. 23

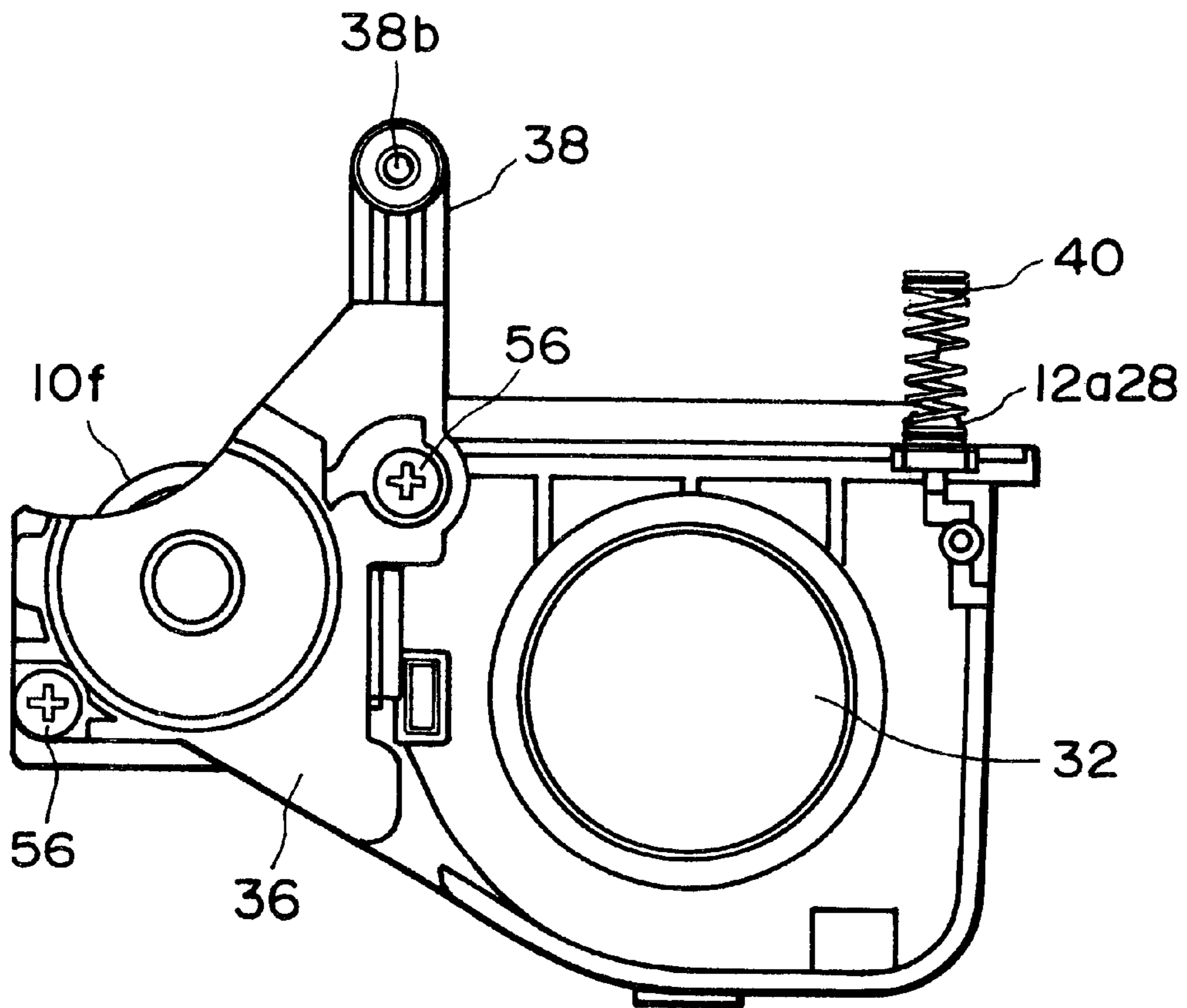

FIG. 24

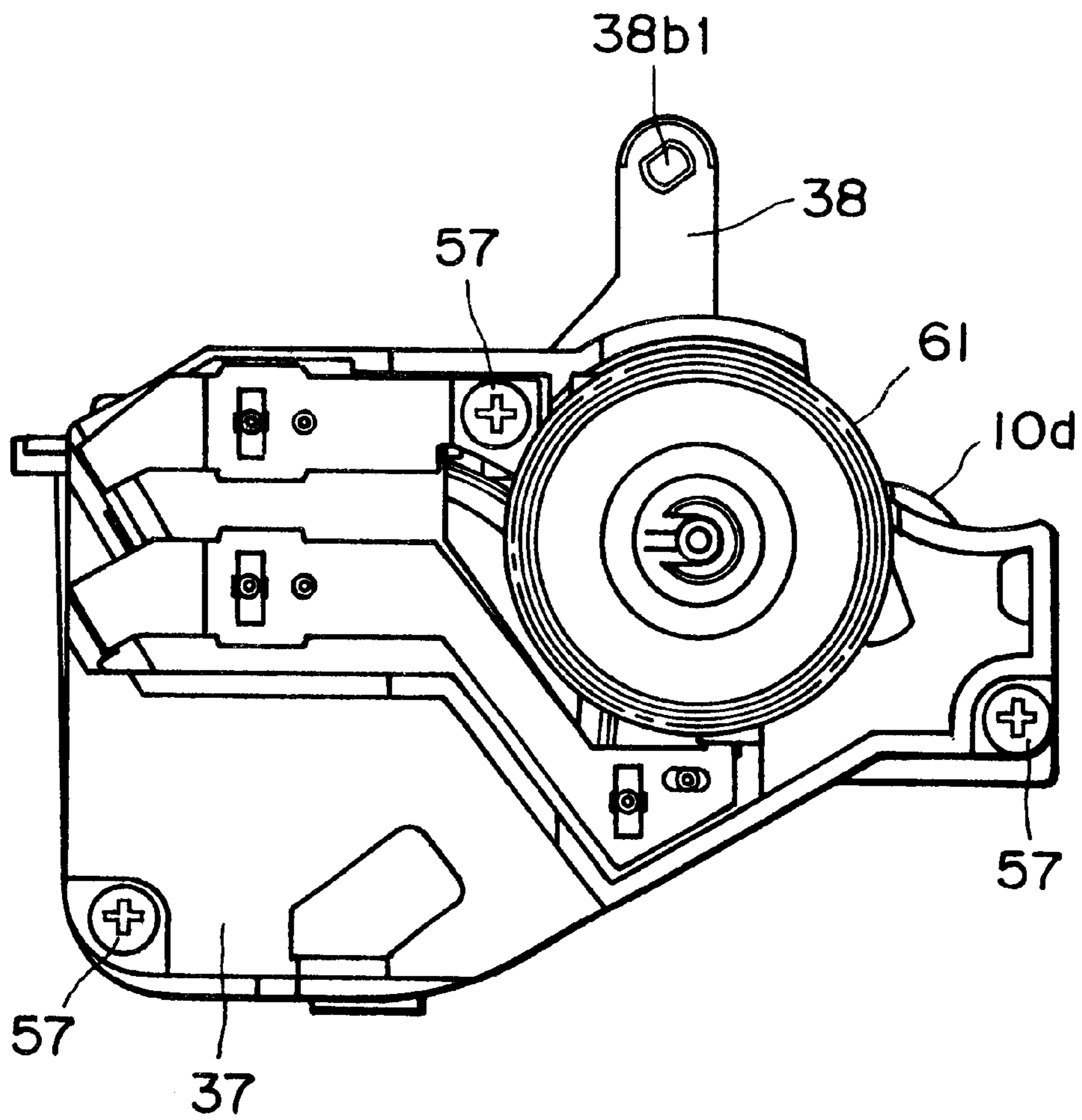

FIG. 25

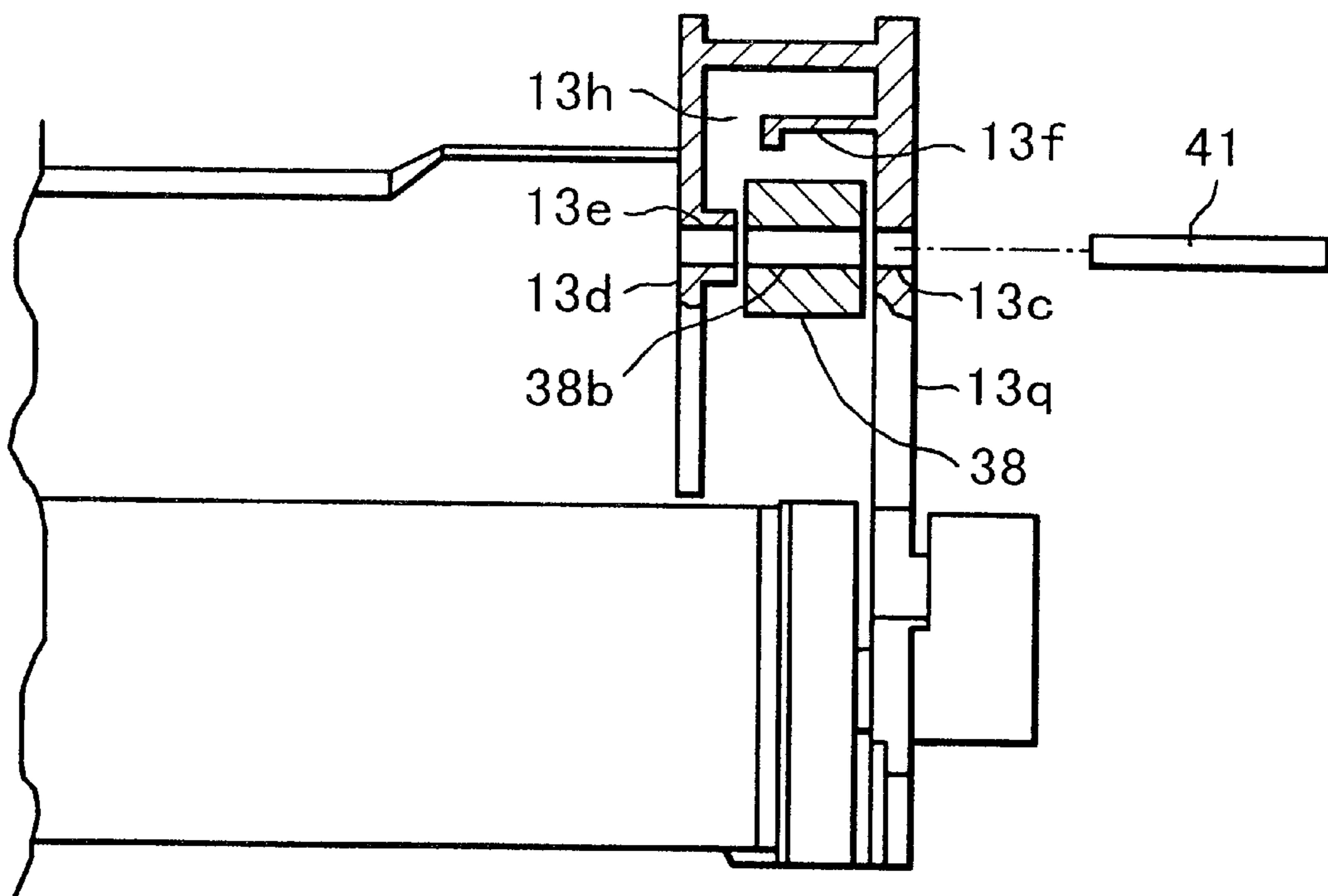

FIG. 26

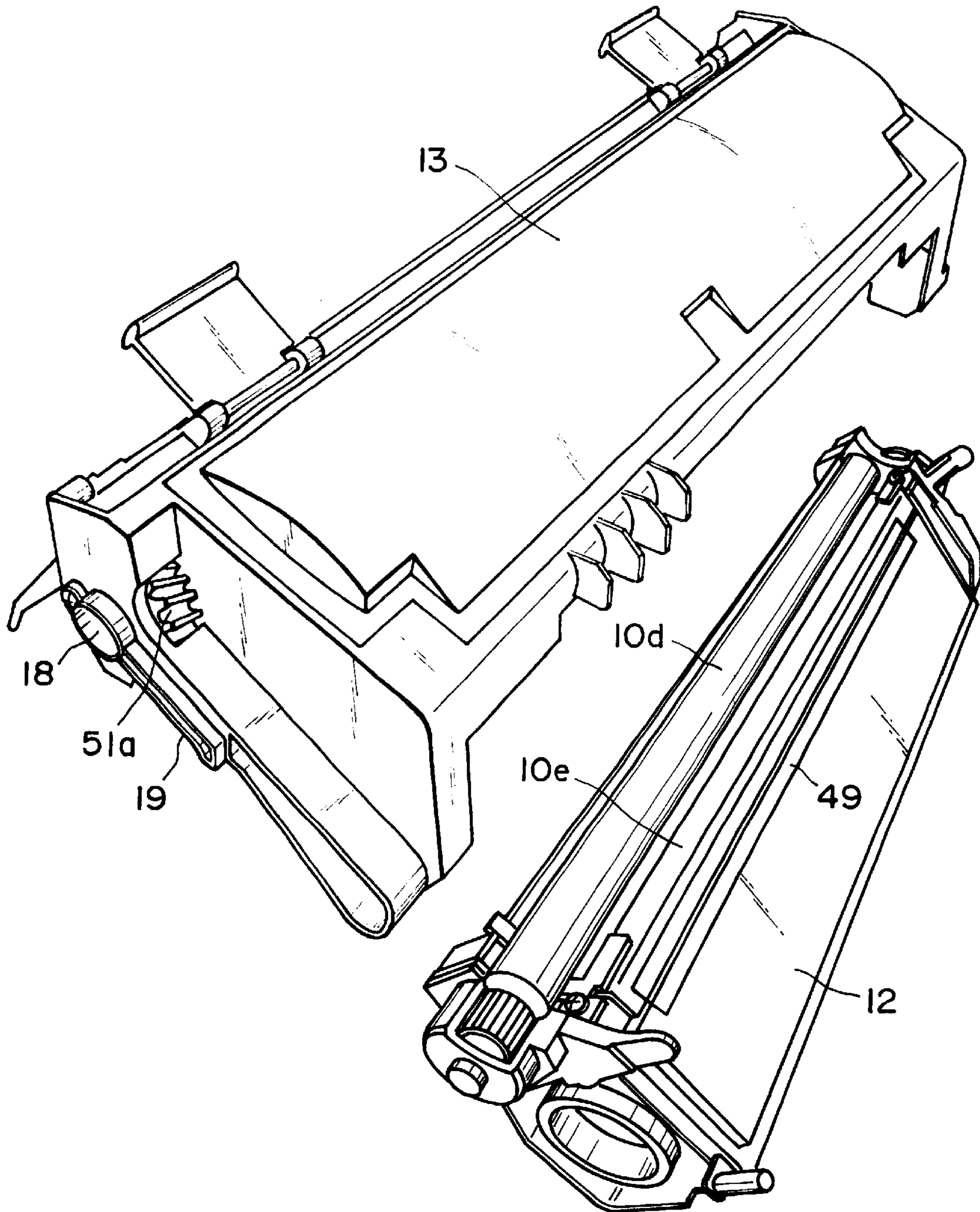

FIG. 27

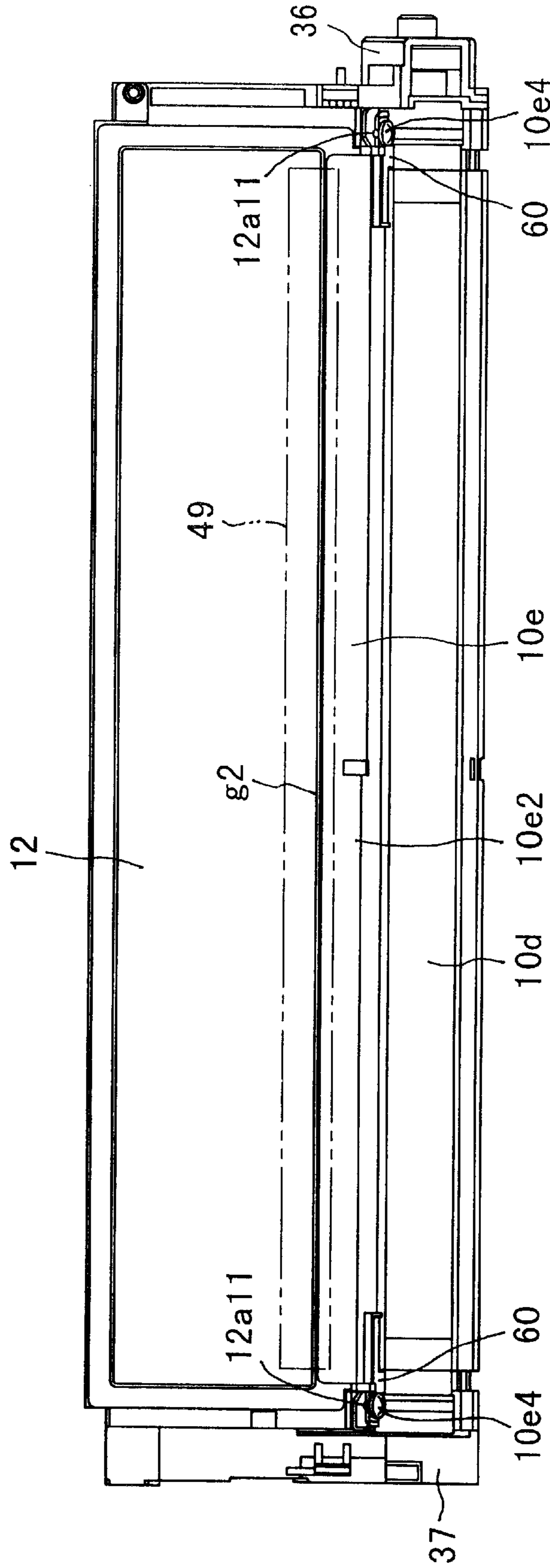

FIG. 28

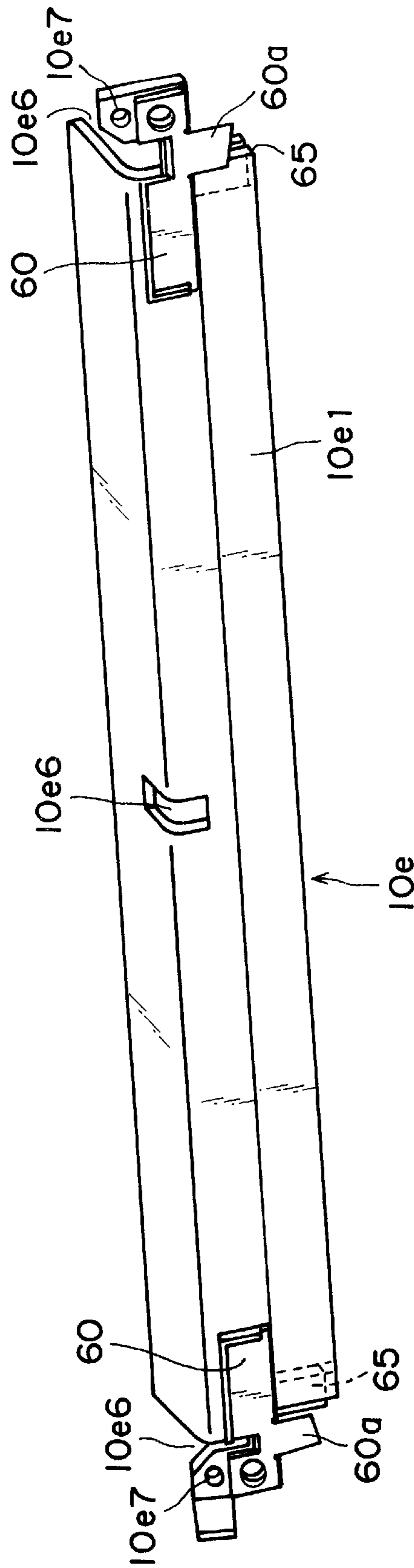

FIG. 29

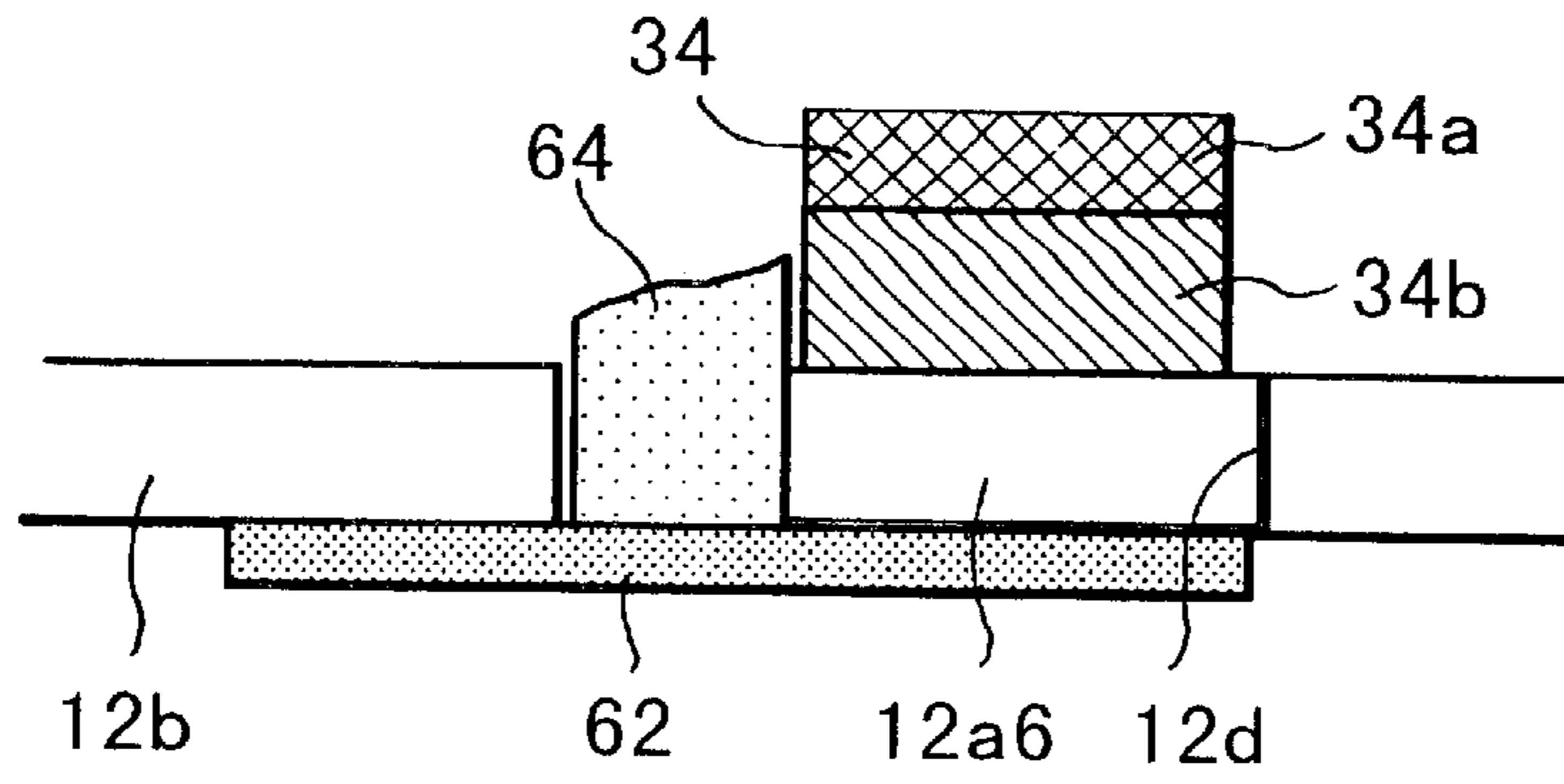

FIG. 30

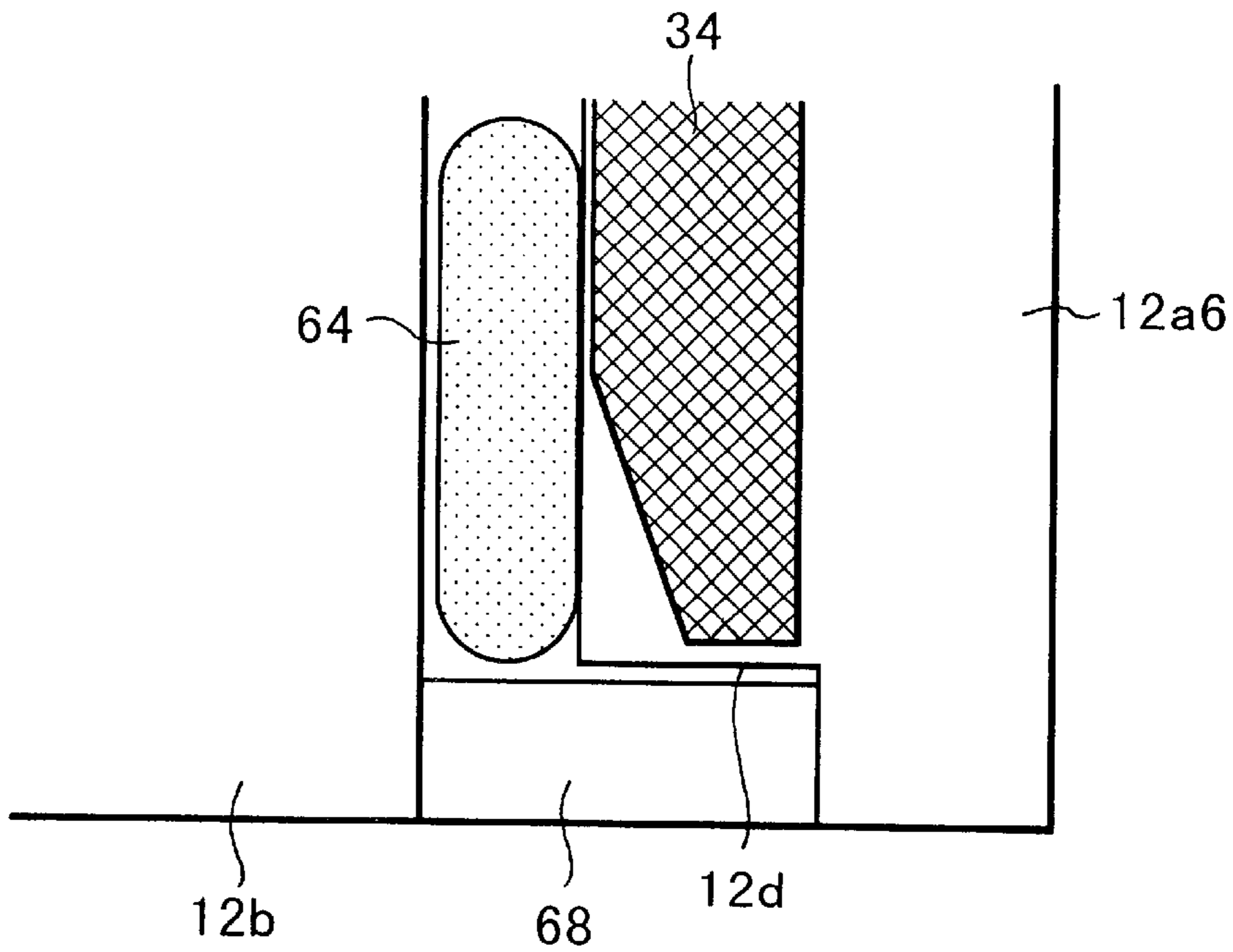

FIG. 31

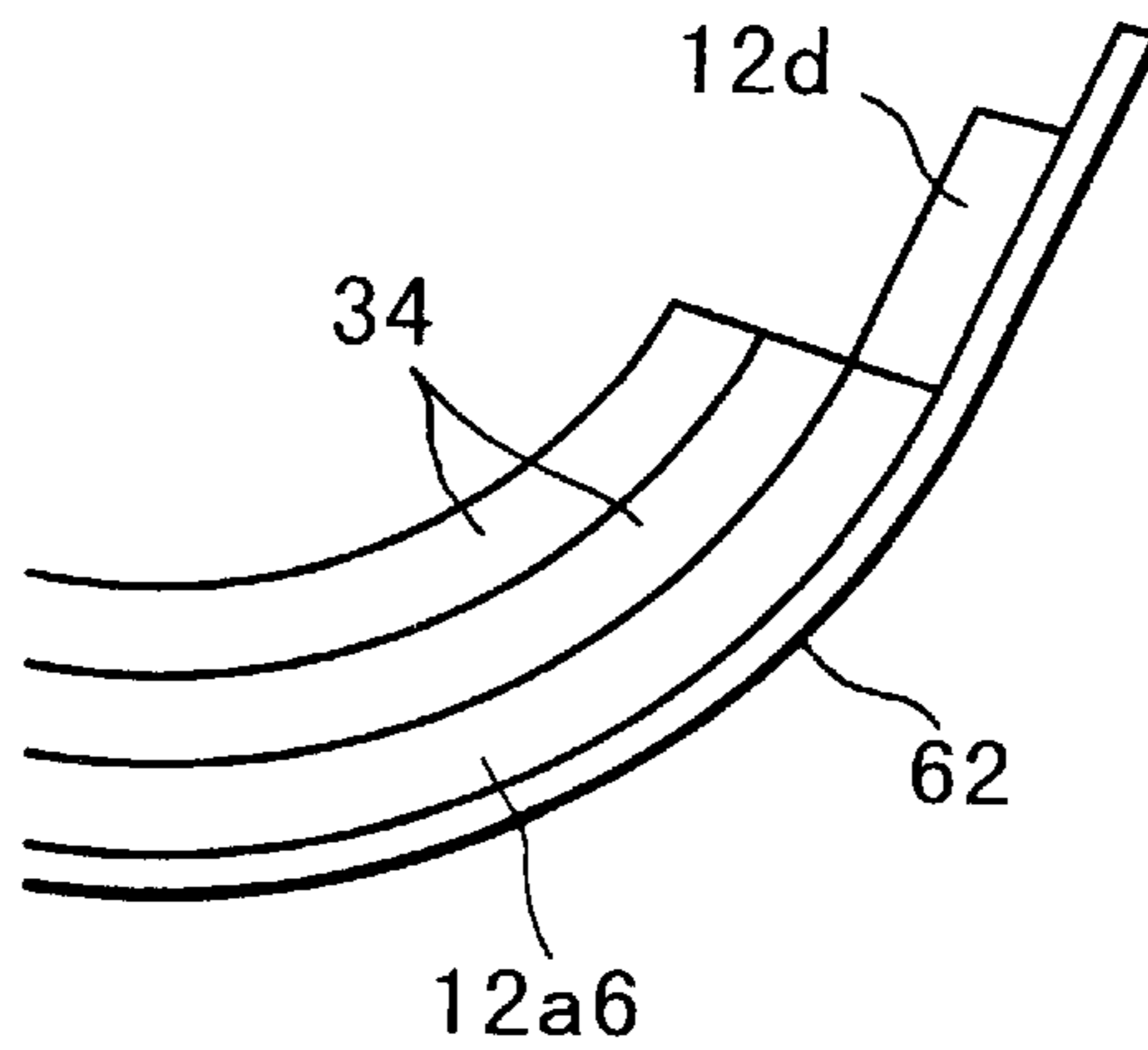

FIG. 32

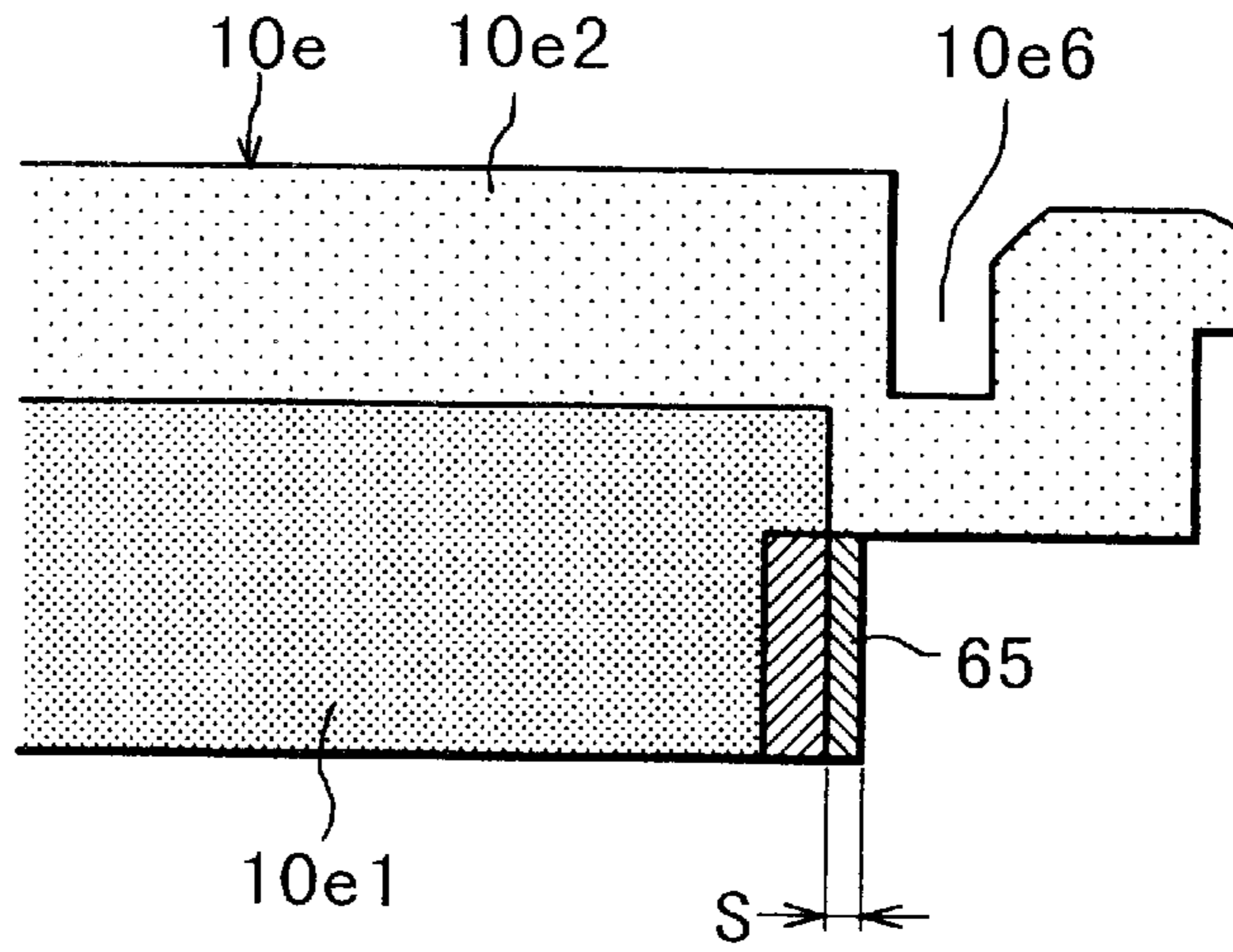

FIG. 33

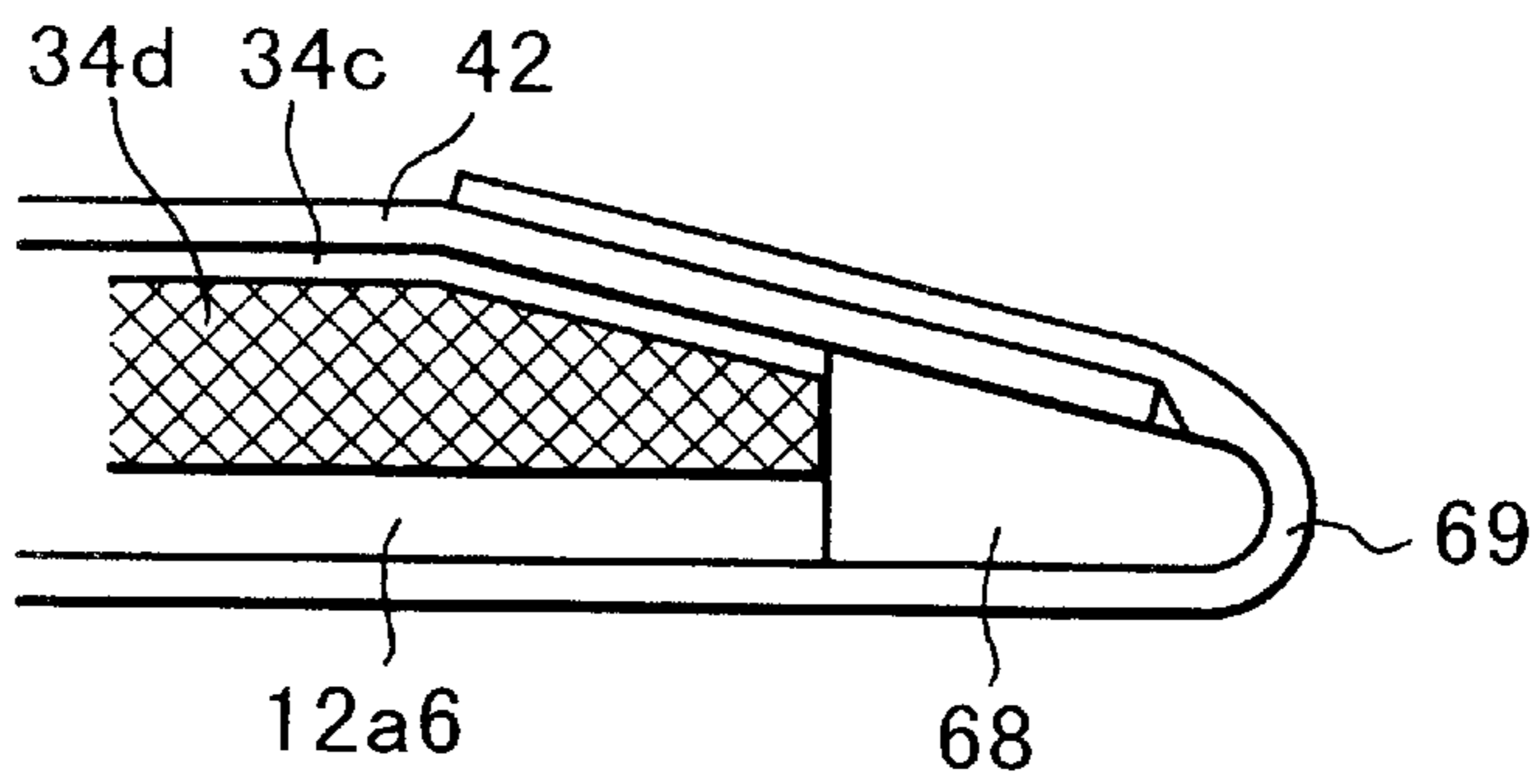

FIG. 34

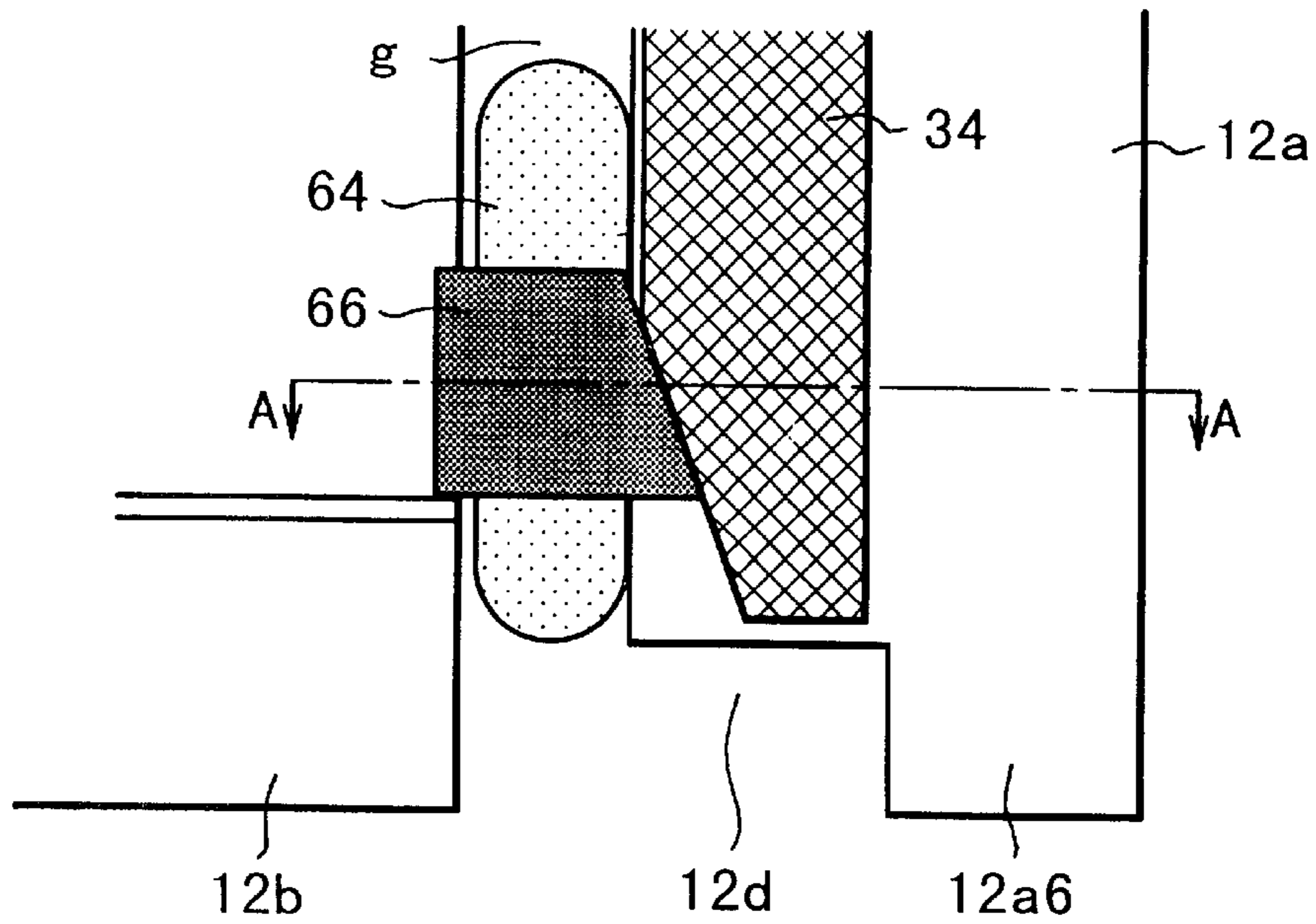

FIG. 35

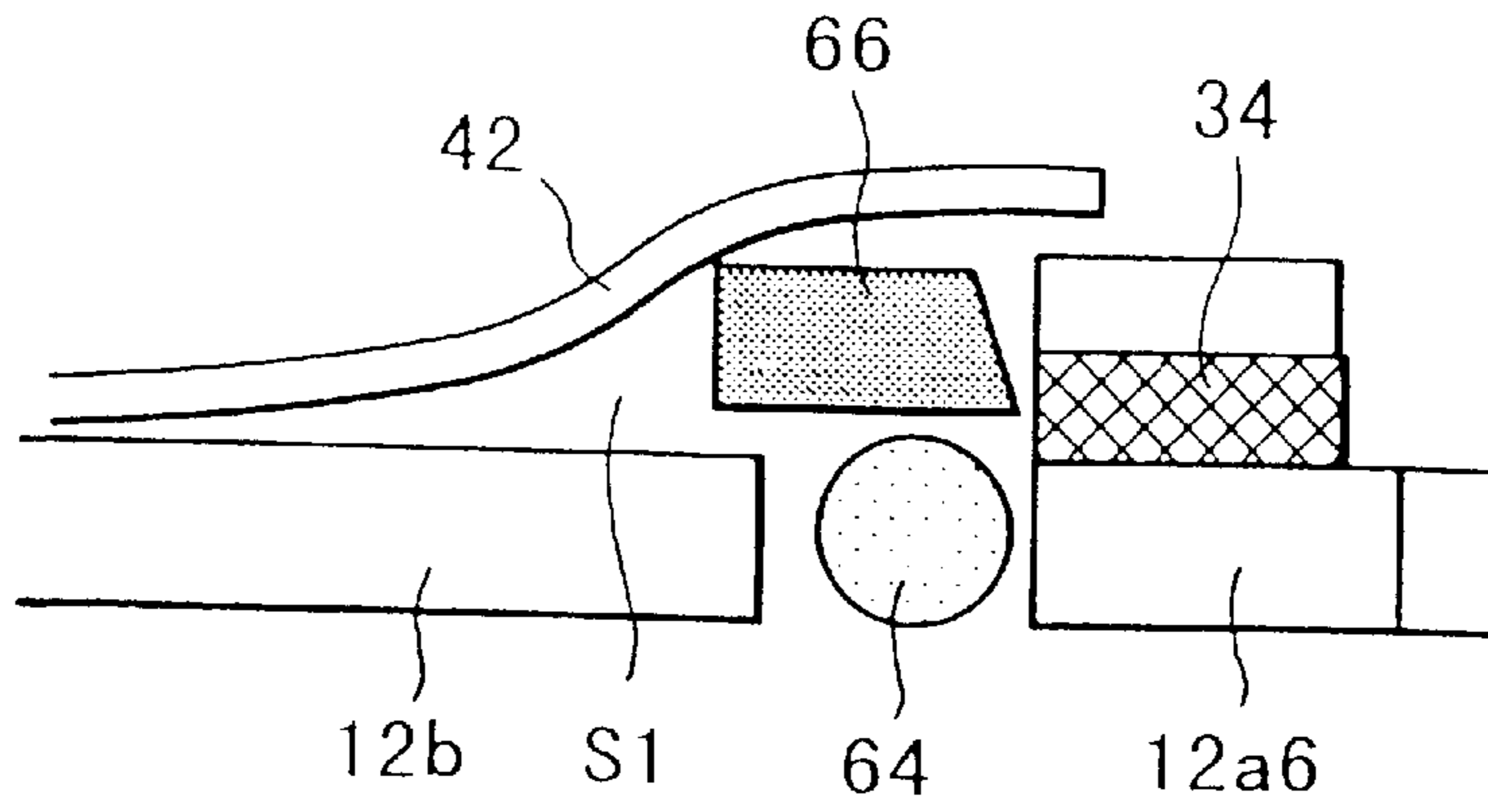

FIG. 36

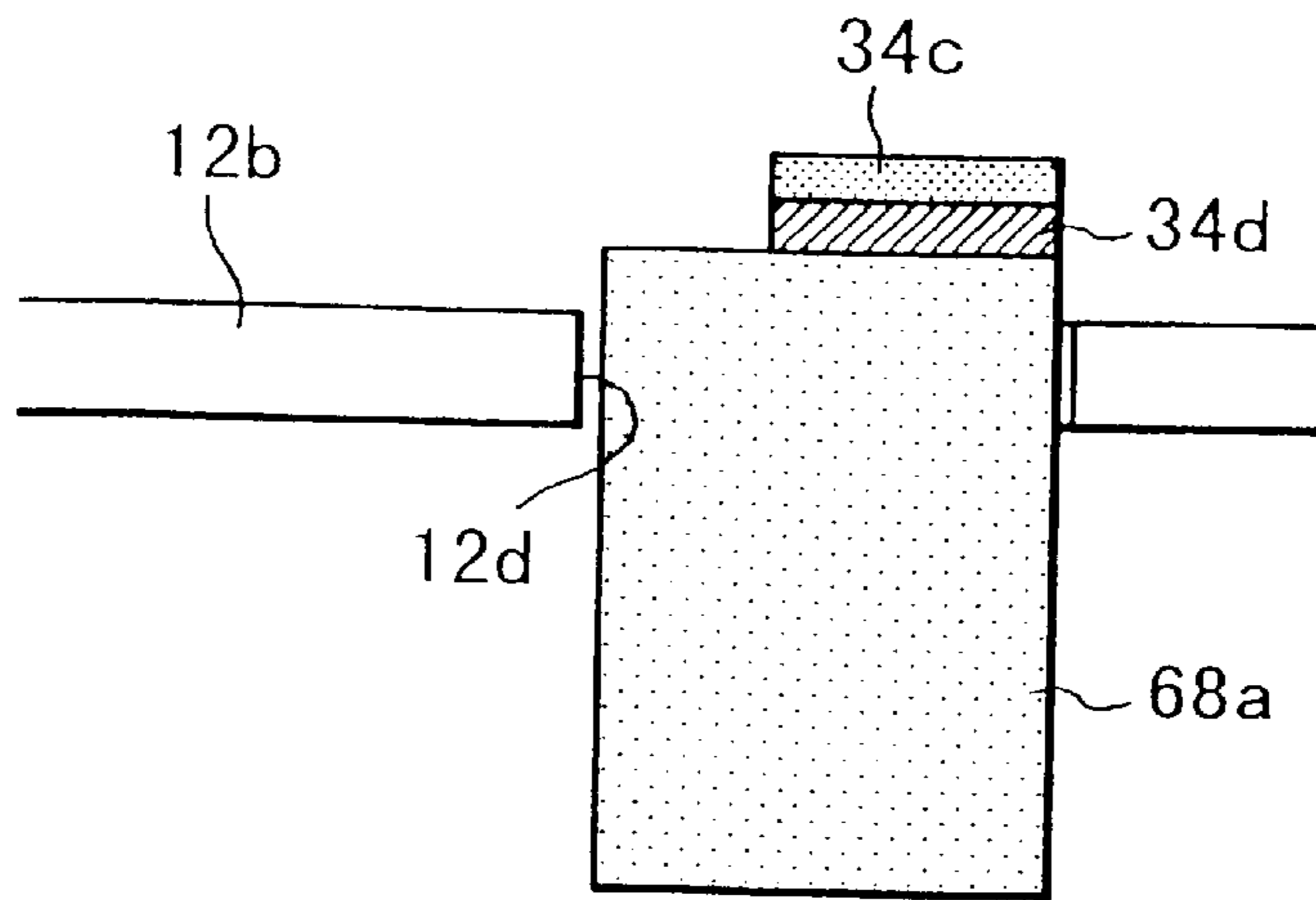

FIG. 37

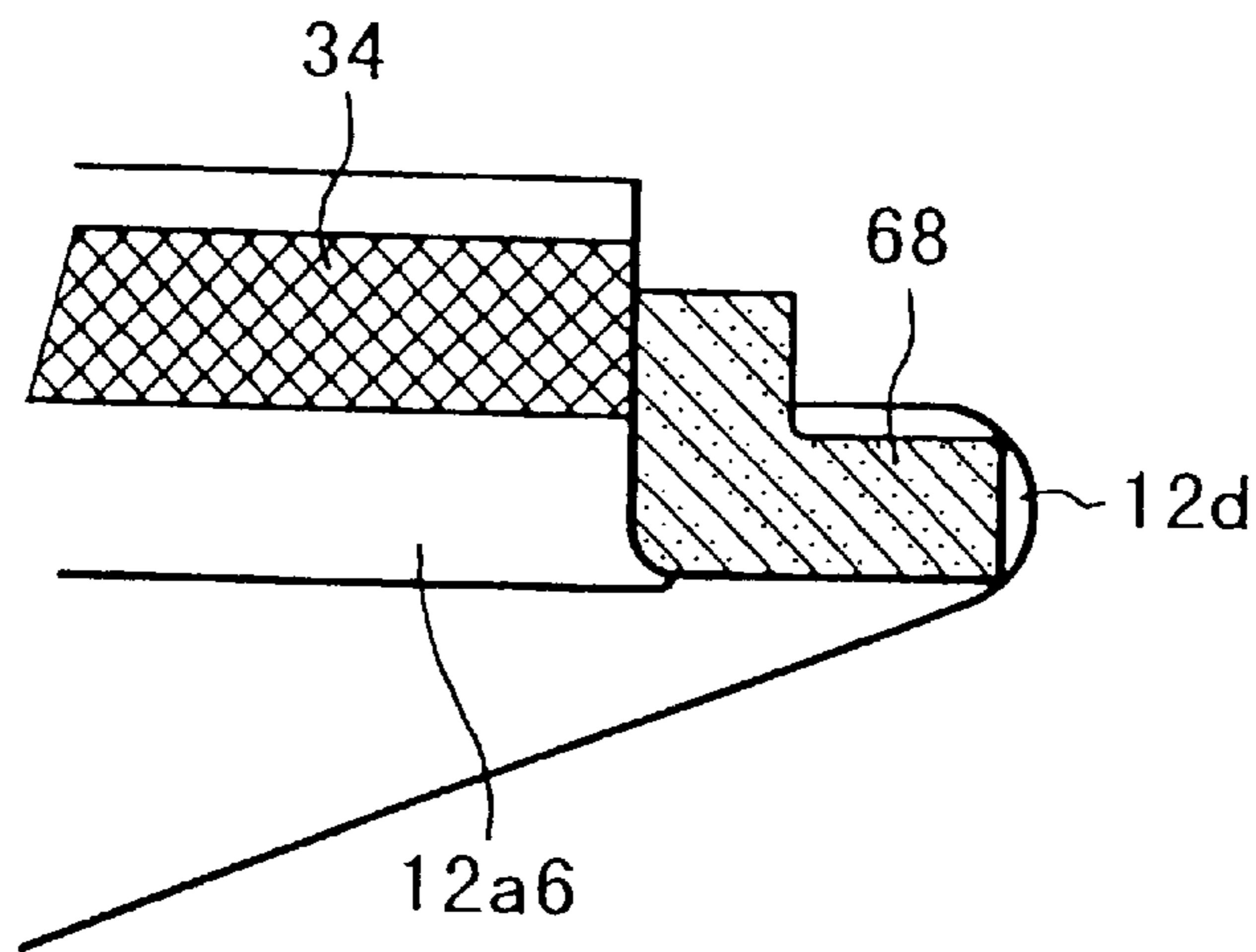

FIG. 38

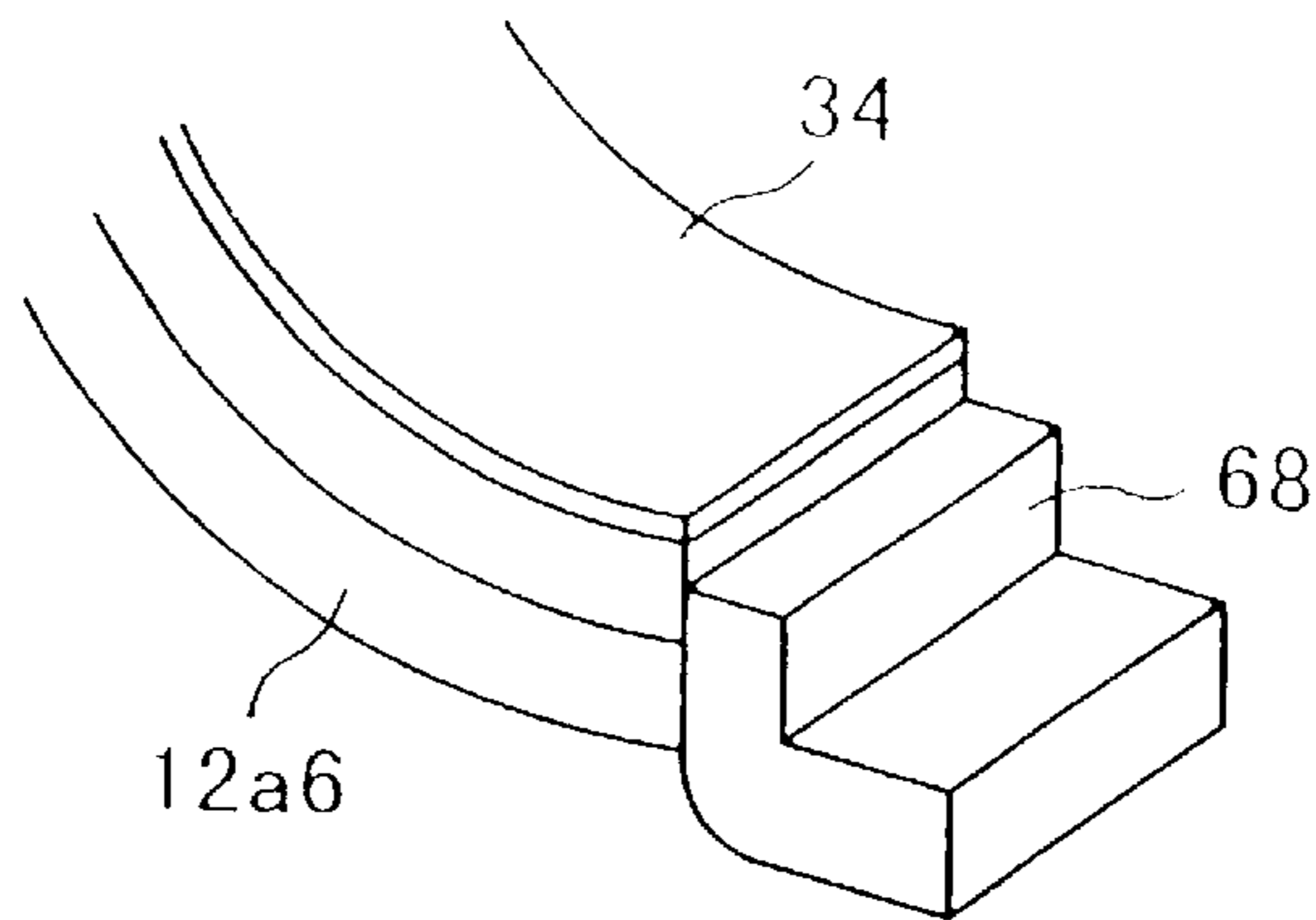

FIG. 39

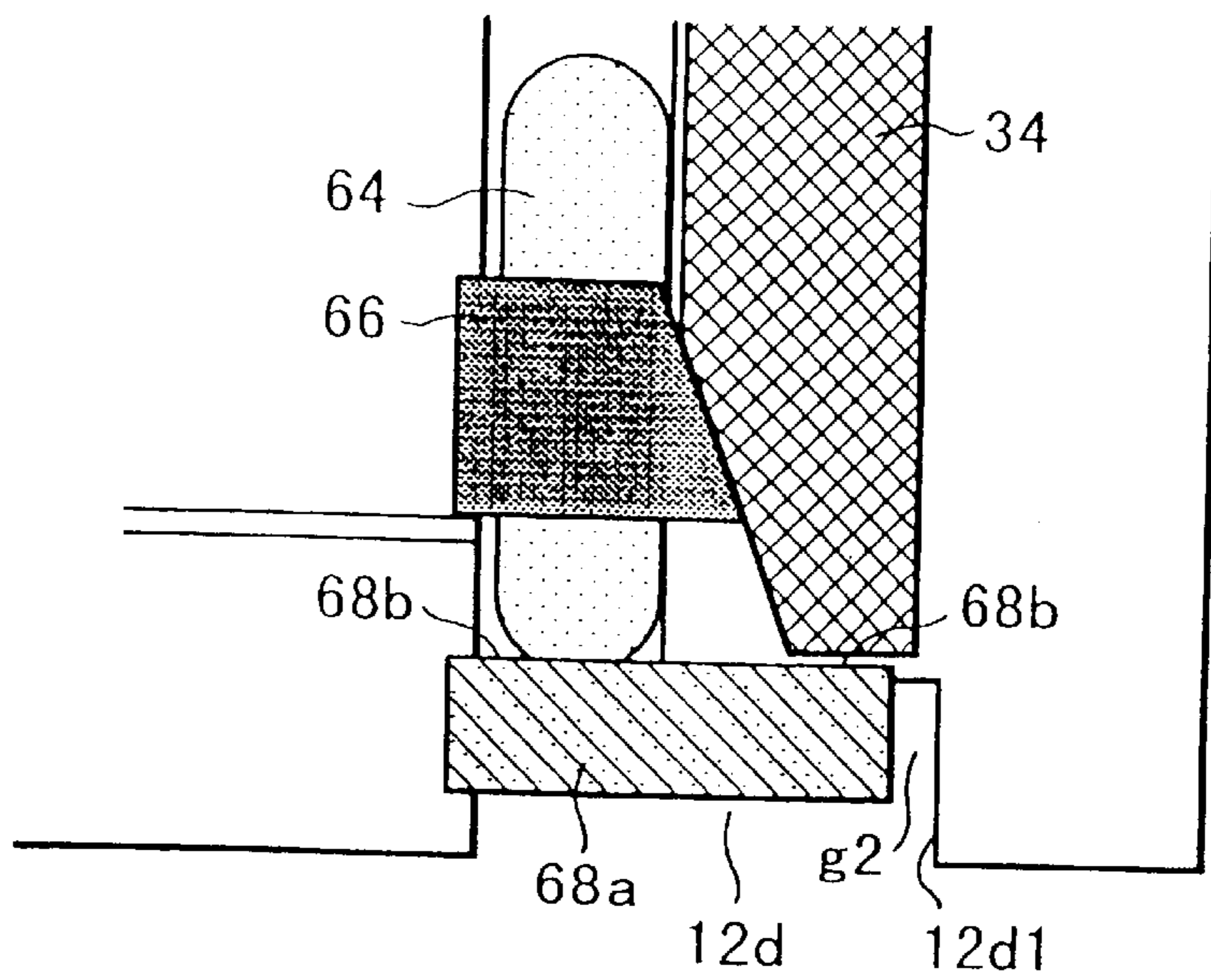

FIG. 40

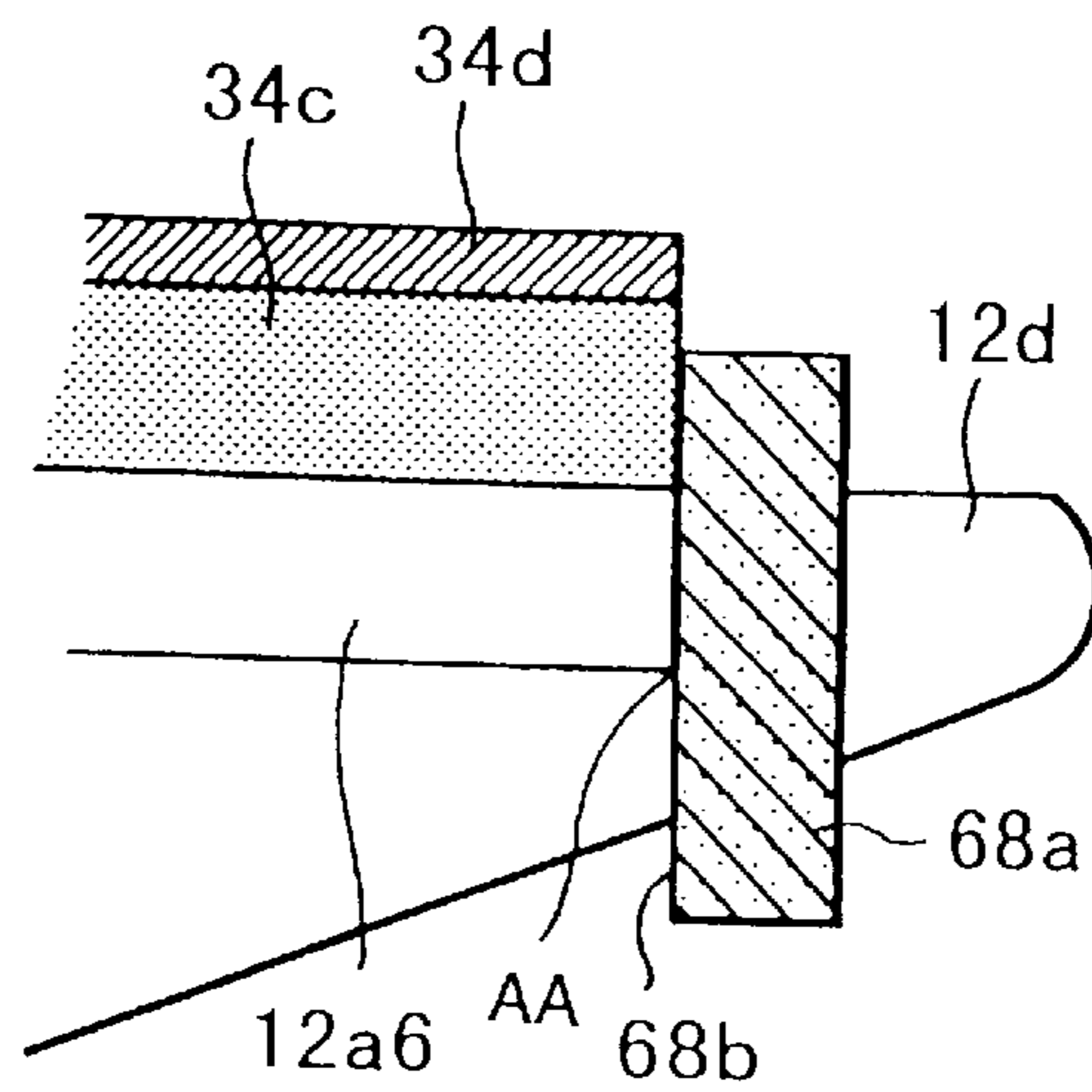

FIG. 41

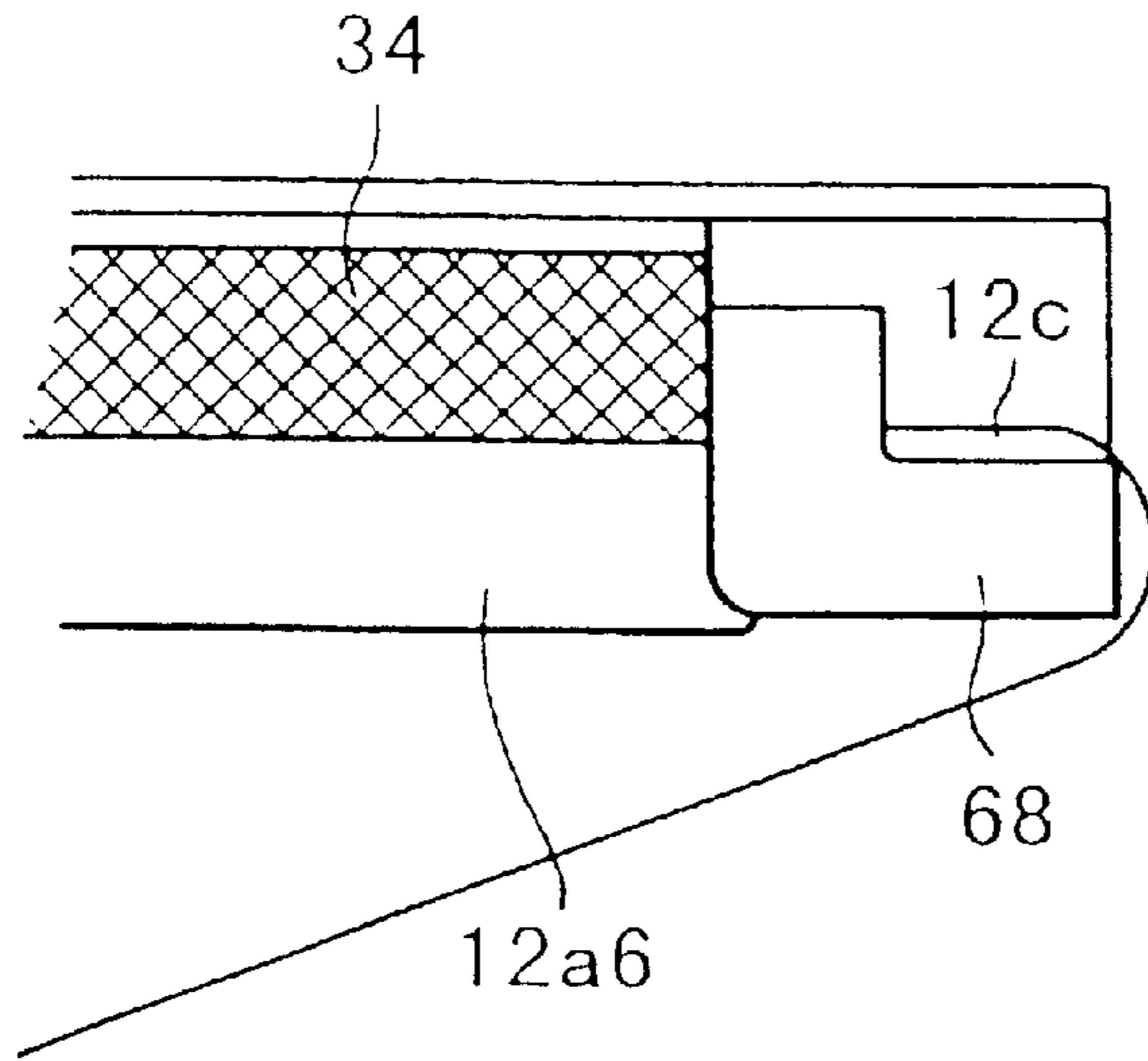

FIG. 42

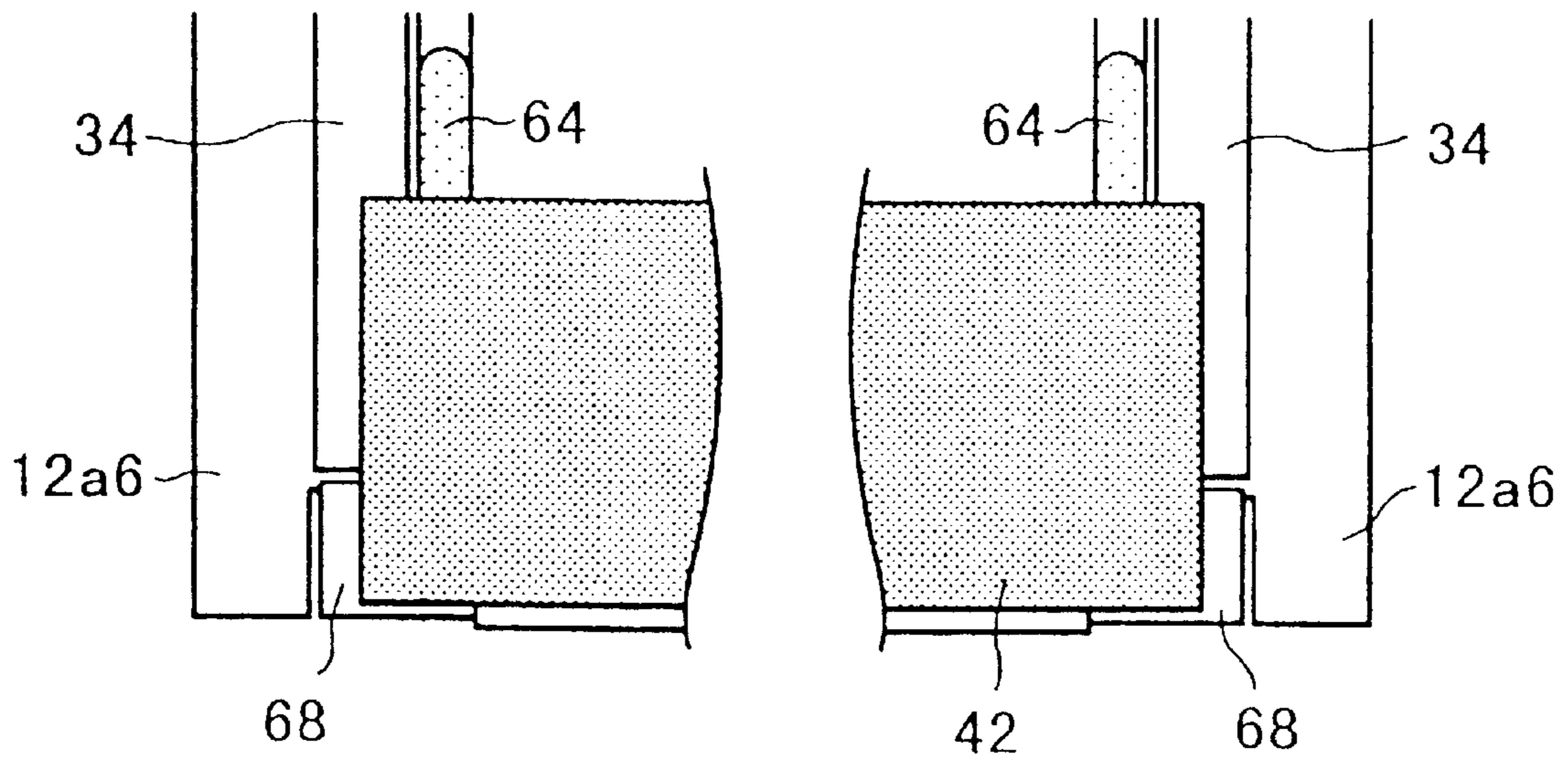

FIG. 43

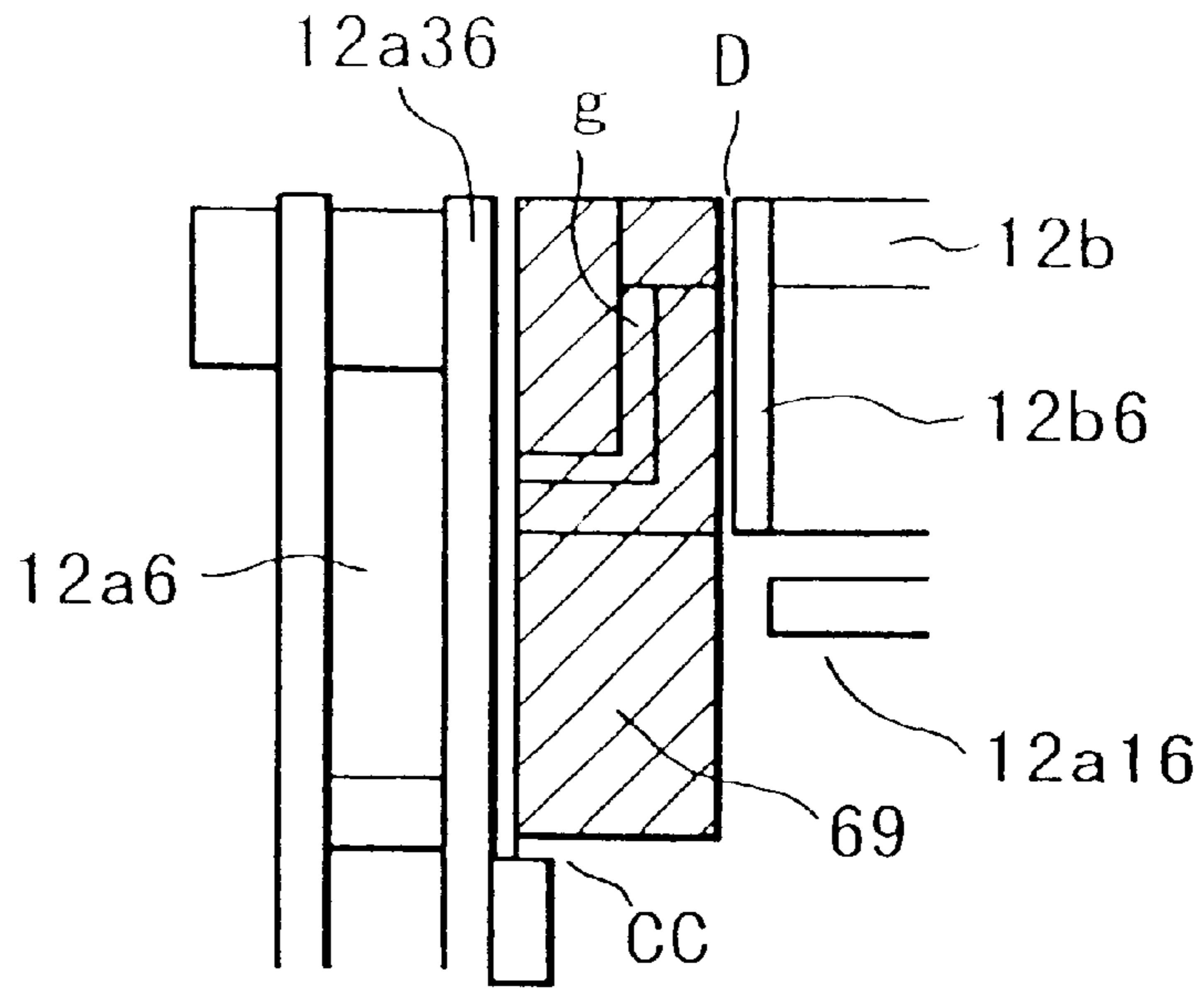

FIG. 44

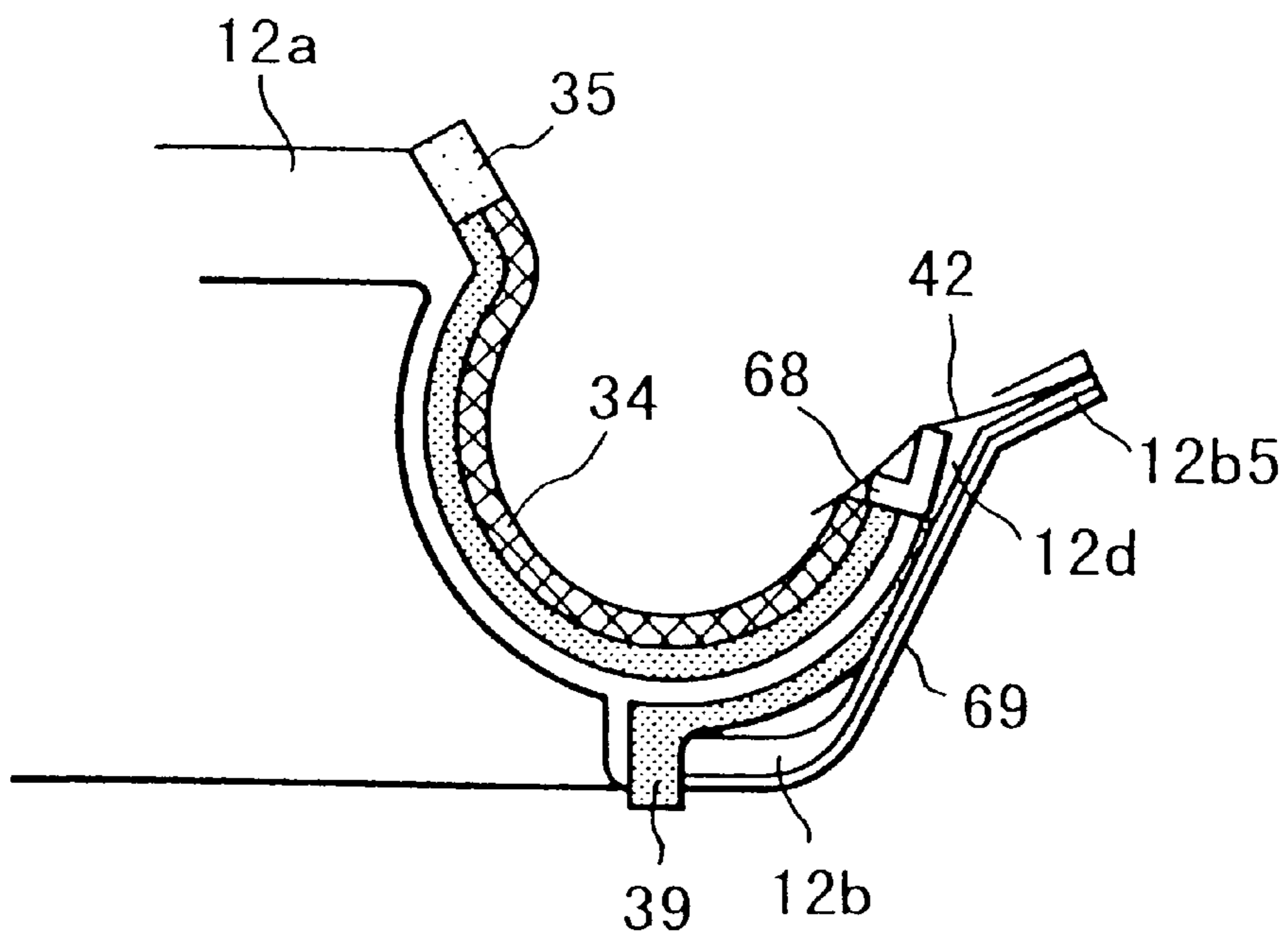

FIG. 45

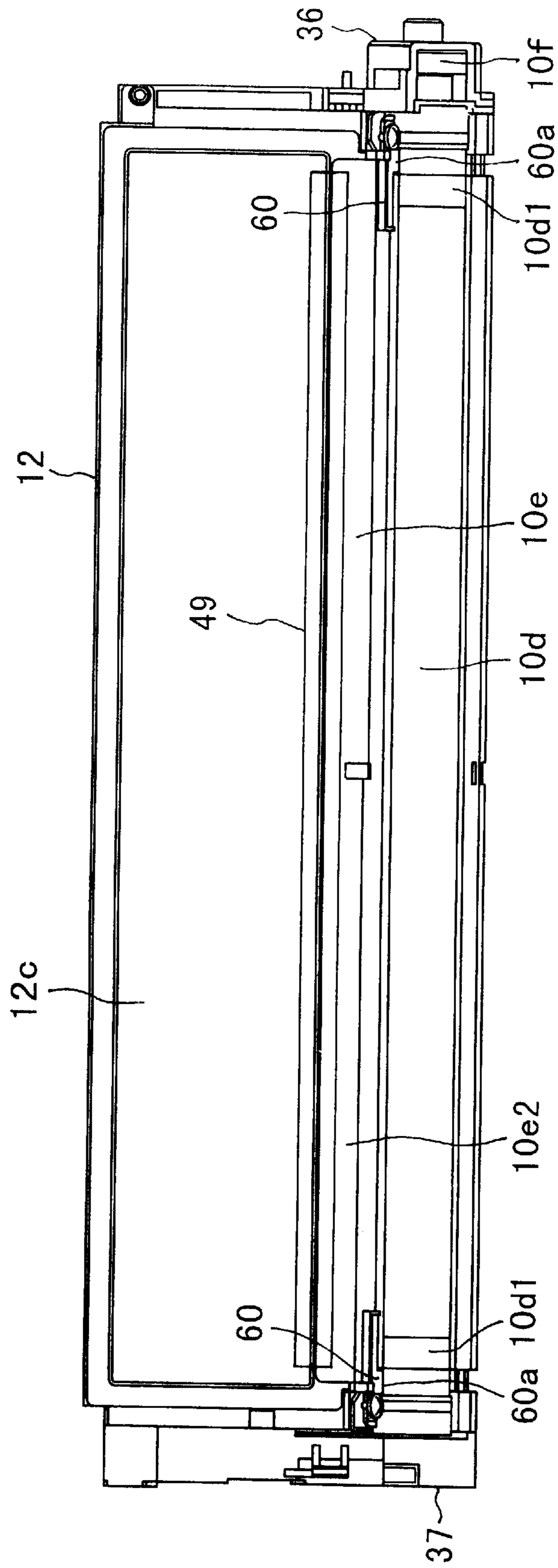

FIG. 46

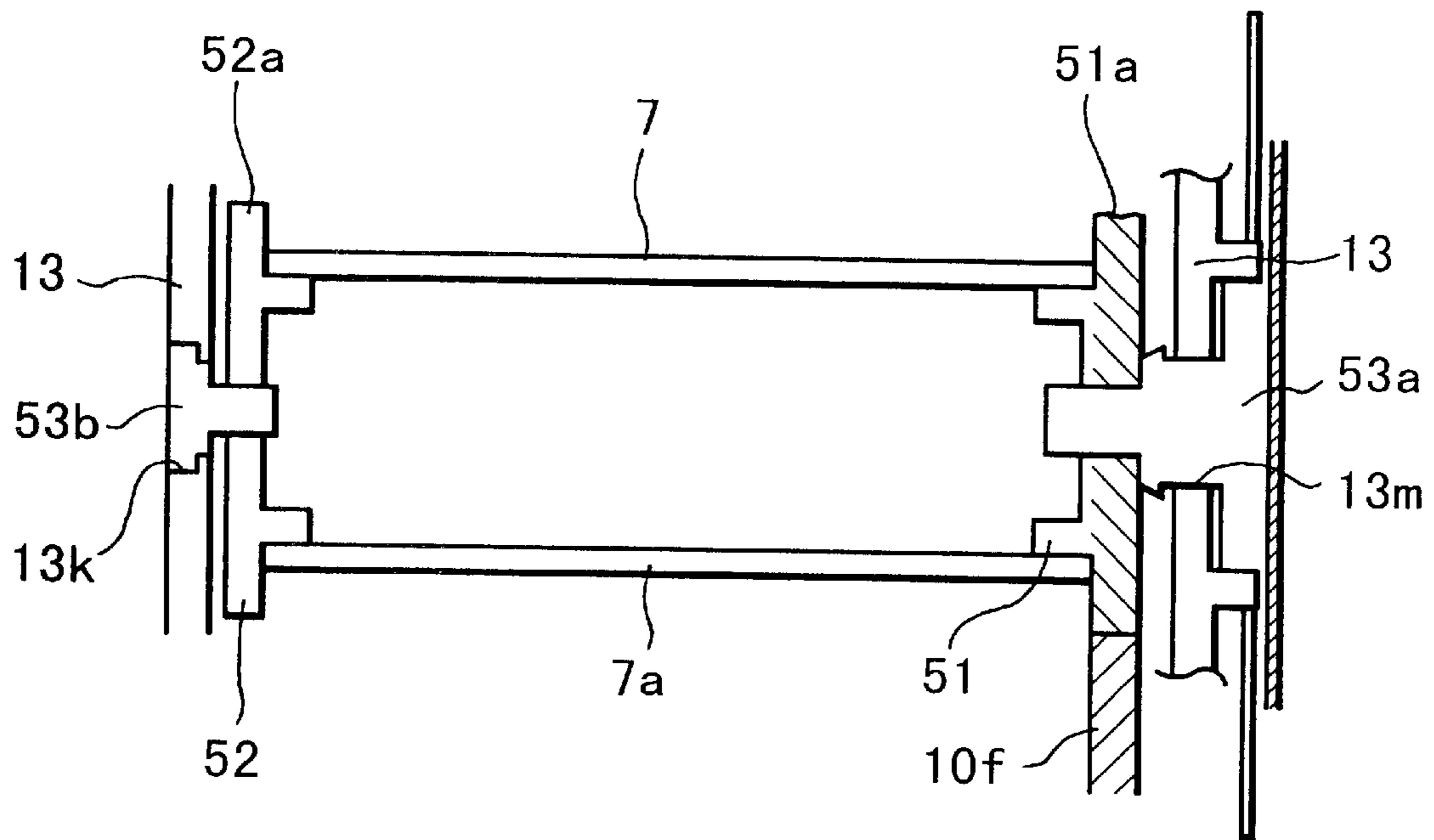

FIG. 47

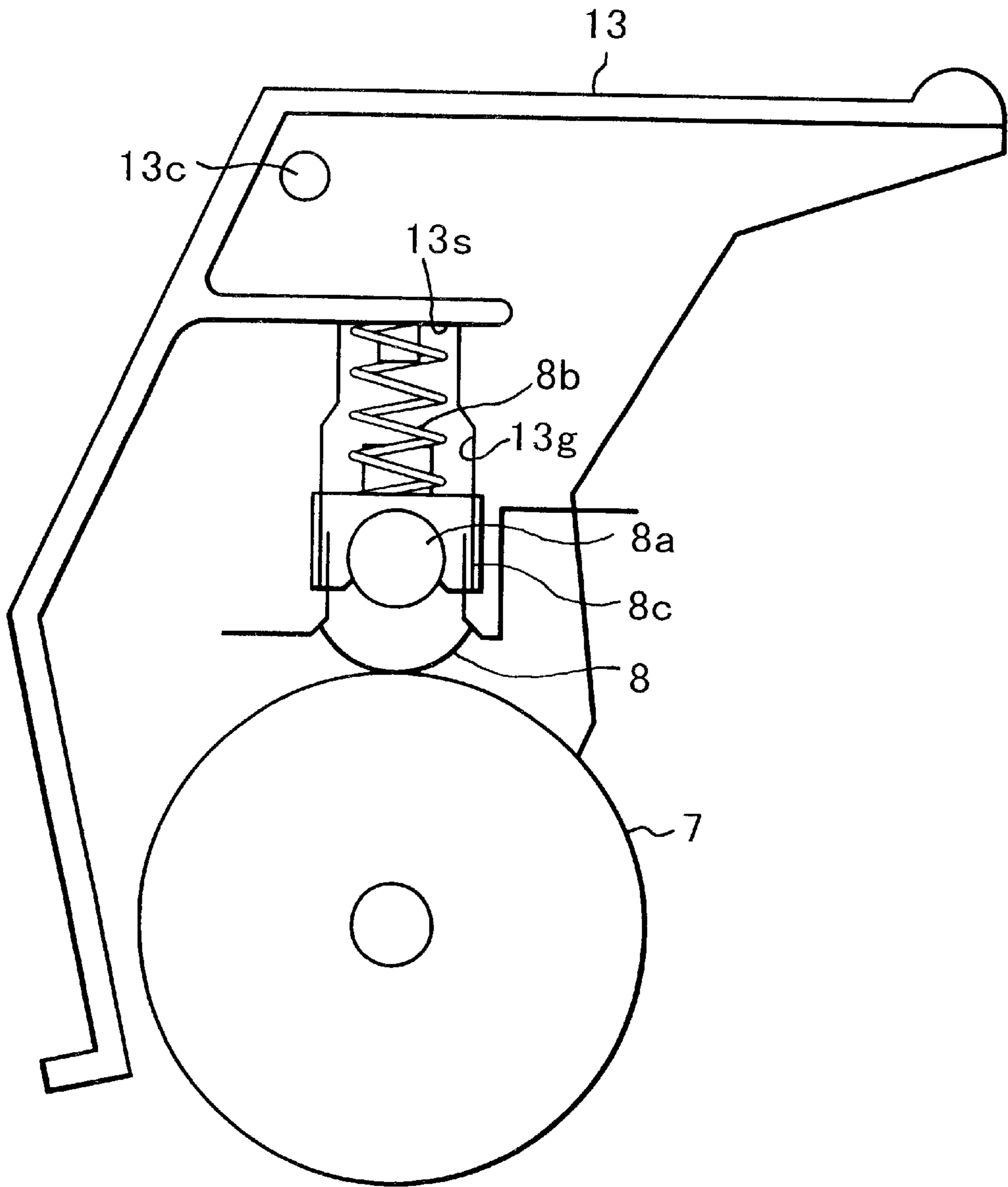

FIG. 48

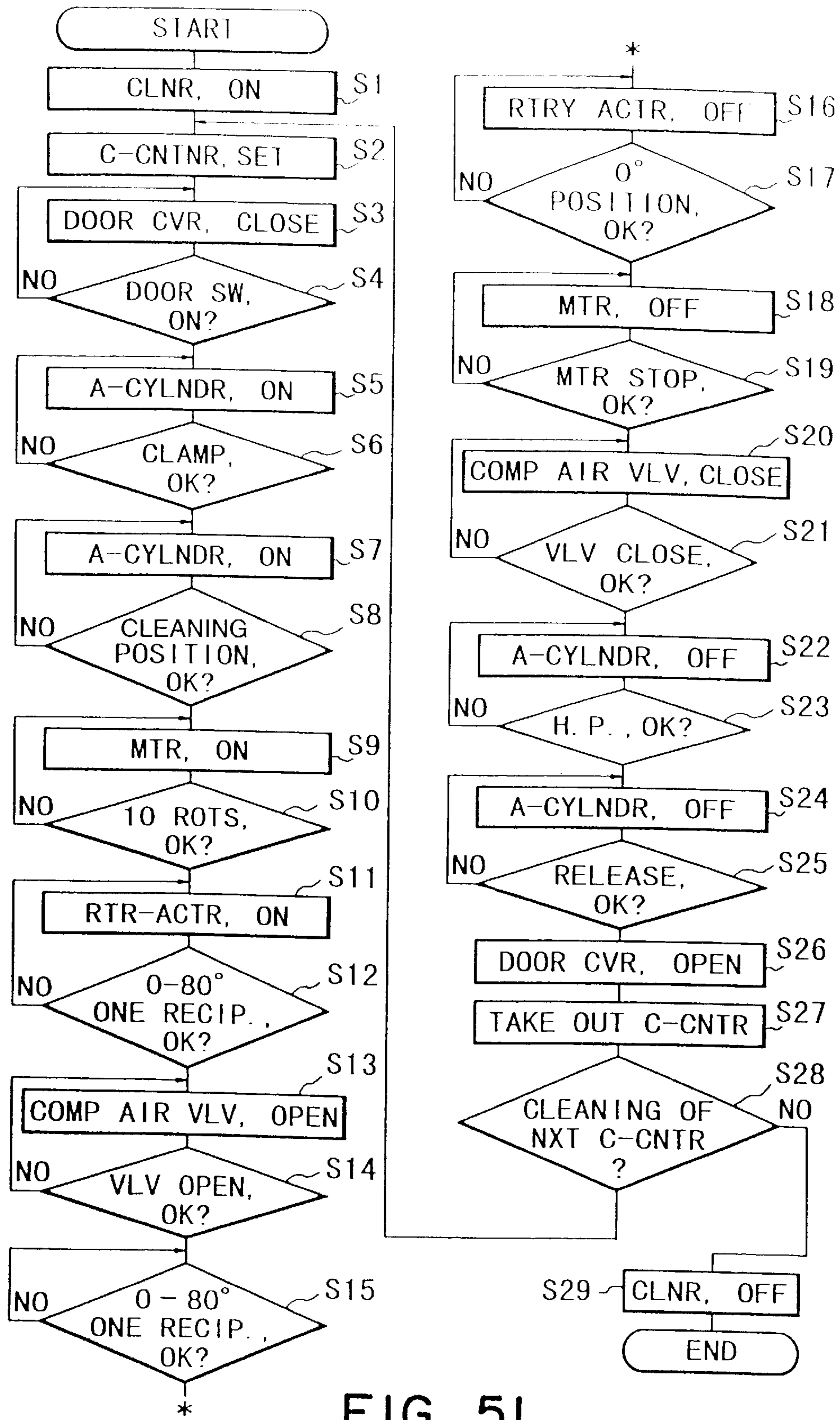

FIG. 51

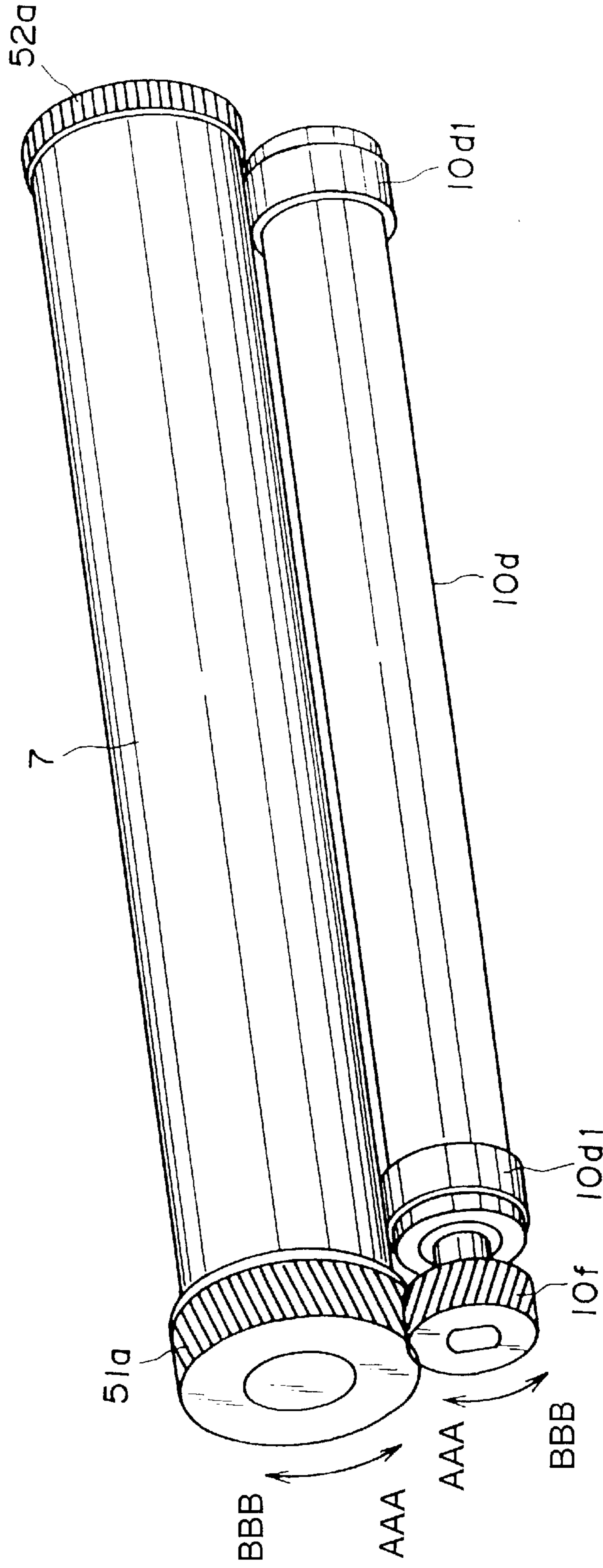

FIG. 52

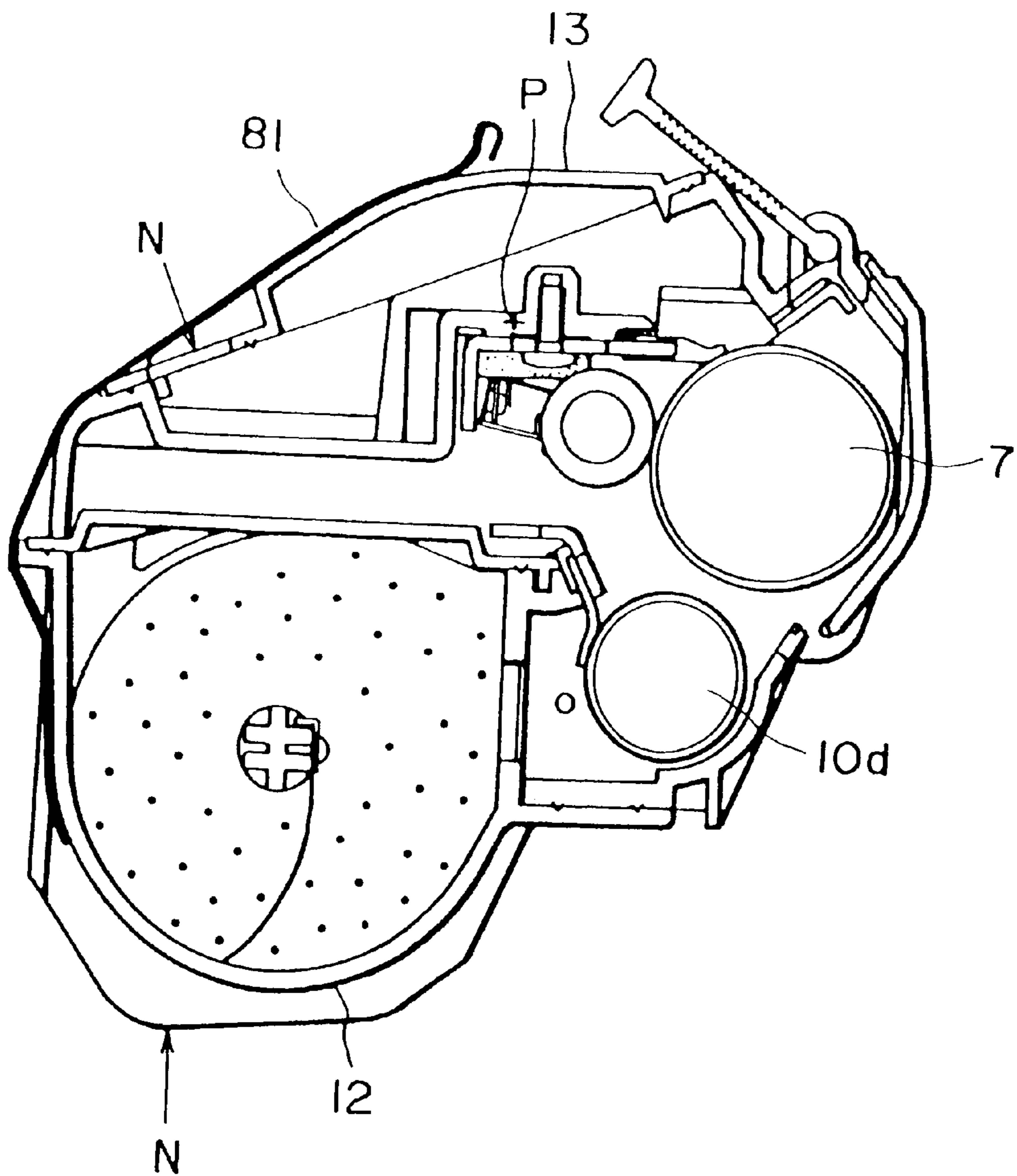

FIG. 53

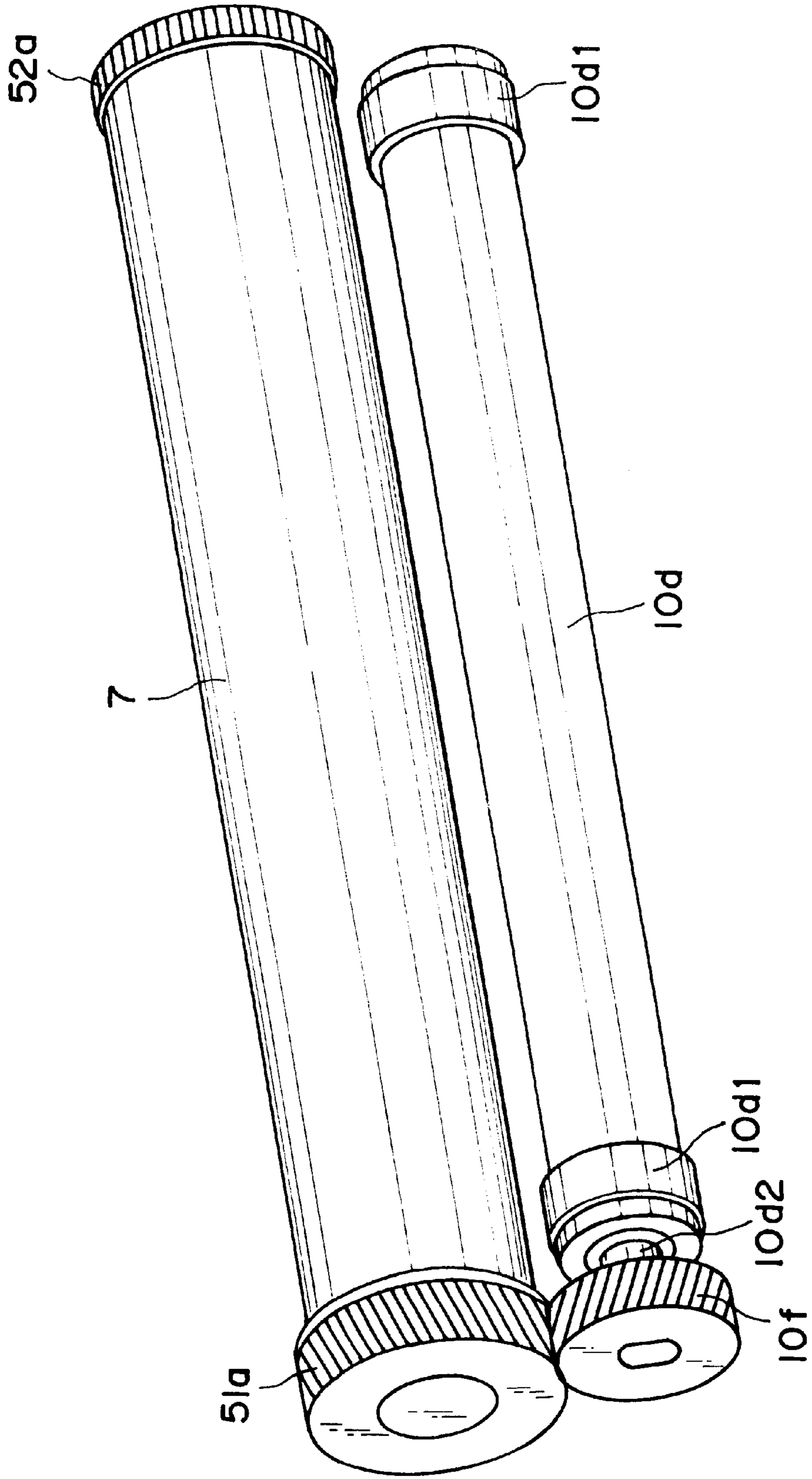

FIG. 54

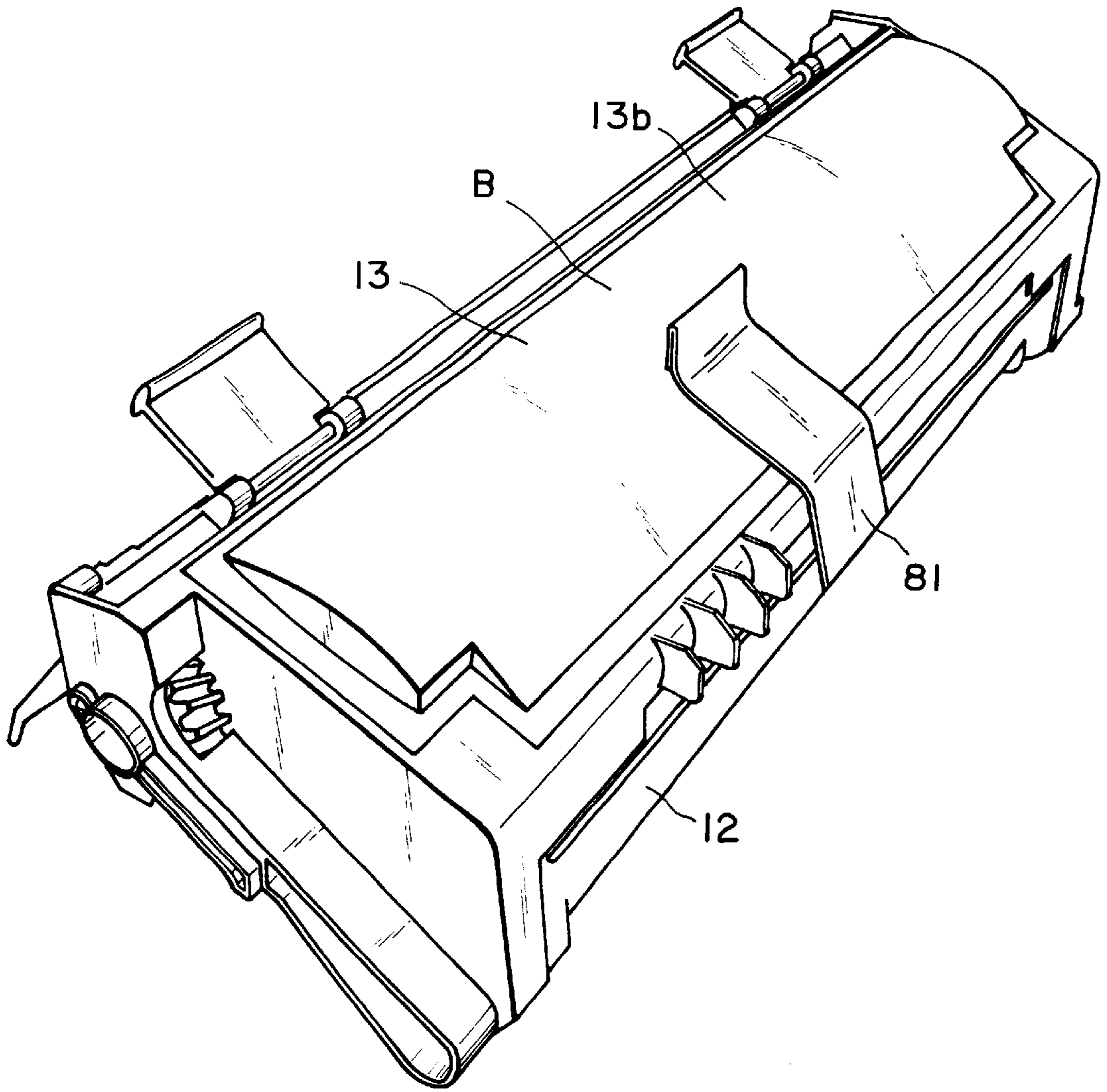

FIG. 55

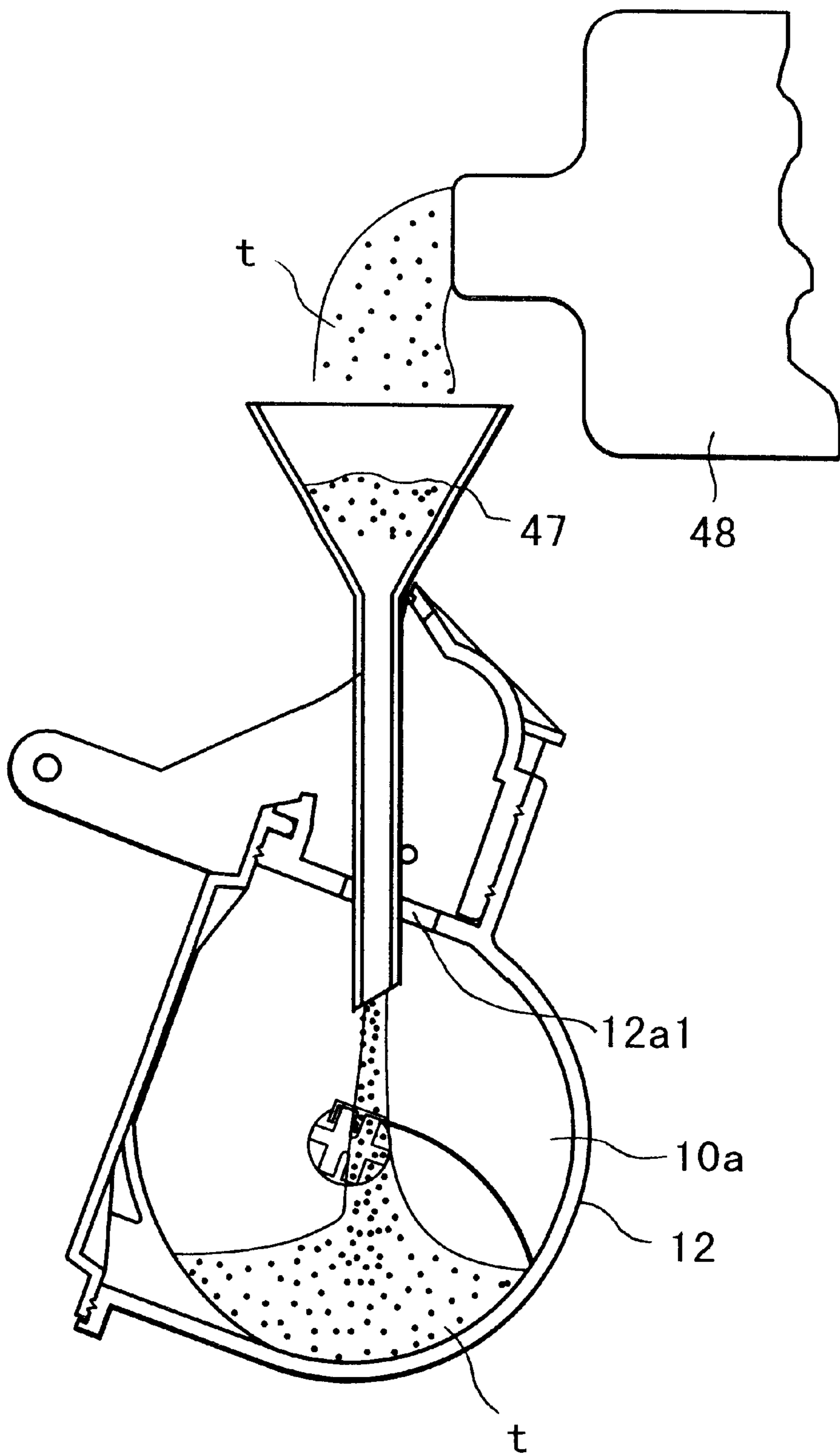

FIG. 56

**PROCESS CARTRIDGE
REMANUFACTURING METHOD**

FIELD OF THE INVENTION AND RELATED
ART

The present invention relates to a remanufacturing method for a process cartridge.

Here, the process cartridge is a cartridge containing at least a developing roller as developing means and an electrophotographic photosensitive member as a unit, the cartridge being detachably mountable to a main assembly of an electrophotographic image forming apparatus.

The electrophotographic image forming apparatus is an apparatus in which an image is formed on a recording material (recording paper, textile or the like) using an electrophotographic image forming process, and includes an electrophotographic copying machine, and an electrophotographic printer (a LED printer, a laser beam printer and so on, an electrophotographic printer type facsimile machine, an electrophotographic word processor and the like).

In an electrophotographic image forming apparatus using an electrophotographic image forming process, a process cartridge is used that integrally contains an electrophotographic photosensitive member and process means actable on the electrophotographic photosensitive member, the process cartridge being detachably mountable to the main assembly of the electrophotographic image forming apparatus. With this process-cartridge type, the maintenance of the apparatus can be carried out in effect without service people. Therefore, the process-cartridge type apparatus is widely used in the field of the electrophotographic image forming apparatus.

Such a process cartridge forms an image on recording material with toner. Therefore, the toner is consumed in accordance with image forming operations. When the toner is consumed up to such an extent that the user is not satisfied with the image quality, the commercial value of the process cartridge is lost.

It is desired that such a used process cartridge is given the commercial value, again by remanufacturing the process cartridge through easy method.

SUMMARY OF THE INVENTION

Accordingly, it is a principal object of the present invention to provide a remanufacturing method of a process cartridge.

It is another object of the present invention to provide a remanufacturing method of a process cartridge in which when the process cartridge is transported, the toner is prevented from leaking out.

It is a further object of the present invention to provide a remanufacturing method of a process cartridge wherein the process cartridge, with which the toner is consumed to such an extent that the user is not satisfied with the image quality, is recycled to be given commercial value.

According to an aspect of the present invention, there is provided a remanufacturing method of remanufacturing a process cartridge comprising:

- (a) a step of preparing a used process cartridge, which comprises a toner developing container, a cleaning container, and pins for coupling the toner developing container and the cleaning container at opposite longitudinal ends of the process cartridge;
- the toner developing container including a toner accommodating portion, a toner supply opening, a developing roller and a developing blade;

the cleaning container including an electrophotographic photosensitive drum;

(b) a container separating step of separating the process cartridge into the toner developing container and the cleaning container by disengaging the pins from the process cartridge;

(c) a blade seal mounting step of mounting a blade seal between a blade mounting plate and an outside of a toner developing frame to seal a gap between the blade mounting plate and the toner developing frame;

(h) a toner refilling step of refilling the toner into the toner accommodating portion of the toner developing container having the blade seal; and

(i) a container coupling step of coupling the toner developing container having the blade seal with the cleaning container by engaging the pins into them.

According to another aspect of the present invention, there is provided a remanufacturing method of remanufacturing a process cartridge comprising:

(a) a step of preparing a used process cartridge which comprises a toner developing container, a cleaning container, and pins for coupling the toner developing container and the cleaning container at opposite longitudinal ends of the process cartridge;

the toner developing container including a toner accommodating portion, a toner supply opening, a developing roller and a developing blade;

the cleaning container including an electrophotographic photosensitive drum;

(b) a container separating step of separating the process cartridge into the toner developing container and the cleaning container by disengaging the pins from the process cartridge;

(c) a developing roller dismantling step of dismantling the developing roller from the toner developing container separated by the container separating step;

(d) a developing blade dismantling step of dismantling the developing blade from the toner developing container separated by the container separating step;

(e) a sealing material filling step of filing a sealing material in a gap formed in the toner developing container and extending along an inner side of an end seal provided adjacent each of longitudinal ends of the developing roller;

(f) an elastic member mounting step of mounting an elastic member longitudinally inside of the end seal provided adjacent each of opposite longitudinal ends of the developing roller, at a position laterally outside of the end seal;

(g) a cut-away portion sealing step of sealing a cut-away portion formed in the toner developing container adjacent each of opposite longitudinal ends of the developing roller, at a position laterally outside of the end seal;

(h) a developing blade mounting step of mounting the developing blade on the toner developer container;

(i) a blade seal mounting step of mounting a blade seal between a blade mounting plate and an outside of a toner developing frame to seal a gap between the blade mounting plate and the toner developing frame;

(j) a developing roller mounting step of mounting the developing roller on the toner developer container;

(k) a toner refilling step of refilling the toner into the toner accommodating portion of the toner developing container having the blade seal; and

(l) a container coupling step of coupling the toner developing container having the blade seal with the cleaning container by engaging the pins into them.

According to a further aspect of the present invention, there is provided a remanufacturing method of remanufacturing a process cartridge comprising:

(a) a step of preparing a used process cartridge which comprises a toner developing container, a cleaning container, and pins for coupling the toner developing container and said cleaning container at opposite longitudinal ends of the process cartridge;

the toner developing container including a toner accommodating portion, a toner supply opening, a developing roller and a developing blade;

the cleaning container including an electrophotographic photosensitive drum;

(b) a container separating step of separating the process cartridge into the toner developing container and the cleaning container by disengaging the pins from the process cartridge;

(c) a developing roller dismantling step of dismantling the developing roller from the toner developing container separated by the container separating step;

(d) a developing blade dismantling step of dismantling the developing blade from the toner developing container separated by the container separating step;

(e) a sealing member mounting step of mounting a sealing member on a side of the developing blade which is away from the developing roller adjacent each of opposite longitudinal ends thereof;

(h) a developing blade mounting step of mounting the developing blade on the toner developer container;

(i) a developing roller mounting step of mounting the developing roller on the toner developer container;

(j) a toner refilling step of refilling the toner into the toner accommodating portion of the toner developing container having the blade seal; and

(k) a container coupling step of coupling the toner developing container having the blade seal with the cleaning container by engaging the pins into them.

According to a further aspect of the present invention, there is provided a remanufacturing method of remanufacturing a process cartridge comprising:

(a) a step of preparing a used process cartridge which comprises a toner developing container, a cleaning container and pins for coupling the toner developing container and the cleaning container at opposite longitudinal ends of the process cartridge;

the toner developing container including a toner accommodating portion, a toner supply opening, a developing roller and a developing blade;

the cleaning container including an electrophotographic photosensitive drum;

(b) a container separating step of separating the process cartridge into the toner developing container and said cleaning container by disengaging the pins from the process cartridge;

(c) a developing roller dismantling step of dismantling the developing roller from the toner developing container separated by the container separating step;

(d) a developing blade dismantling step of dismantling the developing blade from the toner developing container separated by the container separating step;

(e) a sealing material filling step of filing a sealing material in a gap formed in the toner developing

container and extending along an inner side of an end seal provided adjacent each of longitudinal ends of the developing roller;

(f) an elastic member mounting step of mounting an elastic member longitudinally inside the end seal provided adjacent each of opposite longitudinal ends of the developing roller, at a position laterally outside of said the seal;

(g) a cut-away portion sealing step of sealing a cut-away portion formed in the toner developing container adjacent each of opposite longitudinal ends of the developing roller, at a position laterally outside of the end seal;

(h) a sealing member mounting step of mounting a sealing member on a side of the developing blade which is away from the developing roller adjacent each of opposite longitudinal ends thereof;

(i) a developing blade mounting step of mounting the developing blade on the toner developer container;

(j) a blade seal mounting step of mounting a blade seal between a blade mounting plate and an outside of a toner developing frame to seal a gap between the blade mounting plate and the toner developing frame;

(k) a developing roller mounting step of mounting the developing roller on the toner developer container;

(l) a toner refilling step of refilling the toner into the toner accommodating portion of the toner developing container having the blade seal; and

(m) a container coupling step of coupling the toner developing container having the blade seal with the cleaning container by engaging the pins into them.

These and other objects, features and advantages of the present invention will become more apparent upon a consideration of the following description of the preferred embodiments of the present invention taken in conjunction with the accompanying drawings.

BRIEF DESCRIPTION OF THE DRAWINGS

FIG. 1 is a longitudinal sectional view of an electrophotographic image forming apparatus.

FIG. 2 is a longitudinal sectional view of an electrophotographic image forming apparatus.

FIG. 3 is a perspective view of an electrophotographic image forming apparatus.

FIG. 4 is a longitudinal sectional view of a process cartridge.

FIG. 5 is a perspective view of a process cartridge.

FIG. 6 is a side view of a process cartridge.

FIG. 7 is a partly broken side view of a process cartridge.

FIG. 8 is a top plan view of a frame of a toner developing container

FIG. 9 is a side view of a drum shutter.

FIG. 10 is a top plan view of a process cartridge.

FIG. 11 is an exploded perspective view of a toner developing container and a cleaner container.

FIG. 12 is a developed schematic view of a cleaner container.

FIG. 13 is a horizontal sectional view of a toner developing container.

FIG. 14 is a perspective view of a toner developing container without a developing roller.

FIG. 15 is an exploded perspective view of supporting means for the developing roller.

5

FIG. 16 is an exploded perspective view of a toner developing container.

FIG. 17 is a top plan view of a toner developing container from which the developing roller and the developing blade have been removed.

FIG. 18 is an enlarged view of portion E in FIG. 17.

FIG. 19 is an enlarged view of portion F of FIG. 17.

FIG. 20 is a front view of a toner developing container as seen in the direction opposite from the mounting direction of the process cartridge.

FIG. 21 is a longitudinal sectional view of a process cartridge.

FIG. 22 is a side view of a process cartridge.

FIG. 23 is a side view of a process cartridge.

FIG. 24 is a side view of a toner developing container.

FIG. 25 is a side view of a toner developing container.

FIG. 26 is a longitudinal sectional view of a connecting portion between the toner developing container and the cleaner container.

FIG. 27 is a perspective view of a toner developing container and a cleaner container.

FIG. 28 is a top plan view of a toner developing container.

FIG. 29 is a perspective view of a cleaning blade.

FIG. 30 is a front view illustrating a sealing step for a cutaway portion.

FIG. 31 is a top plan view of the device shown in FIG. 30.

FIG. 32 is a side view of the device shown in FIG. 30.

FIG. 33 is a front view of a side pad.

FIG. 34 is a side view after the side cover seal is mounted.

FIG. 35 is a top plan view of an end lateral seal.

FIG. 36 is a front view showing the disposition of the end lateral seal.

FIG. 37 is a front view showing mounting of a FIG. 37 groove filling seal.

FIG. 38 is a side view of the FIG. 38 groove filling seal.

FIG. 39 is a perspective view of the FIG. 39 groove filling seal.

FIG. 40 is a top plan view illustrating mounting of the FIG. 40 groove filling seal.

FIG. 41 is a side view of the device shown in FIG. 40.

FIG. 42 is a side view illustrating a positional relationship between the FIG. 42 groove filling seal and the seal.

FIG. 43 is a top plan view illustrating a positional relationship between the FIG. 43 groove filling seal and the jaw seal.

FIG. 44 is a front view of a developing roller at a longitudinal end of the toner developing container as seen from the lower side.

FIG. 45 is a longitudinal sectional view of an end seal portion.

FIG. 46 is a top plan view of a toner developing container.

FIG. 47 is a longitudinal sectional view of a support structure for the photosensitive drum.

FIG. 48 is a side view of a support structure for the charging roller.

FIG. 49 is a longitudinal sectional view of a cleaning device for a cleaner container.

FIG. 50 is a perspective view of a nozzle of the cleaning device.

FIG. 51 is a flow chart of the cleaning function.

6

FIG. 52 is a perspective view of the photosensitive drum and the developing roller during an image forming operation.

FIG. 53 is a longitudinal sectional view of the process cartridge during the transportation thereof.

FIG. 54 is a perspective view illustrating a relationship between the photosensitive drum and the charging roller during transportation of the process cartridge.

FIG. 55 is a perspective view of a process cartridge during transportation thereof.

FIG. 56 is a longitudinal sectional view of a toner filling according to a further embodiment of the present invention.

DESCRIPTION OF THE PREFERRED EMBODIMENTS

The preferred embodiments of the present invention will be described in conjunction with the accompanying drawing us.

A description will be provided first as to the general arrangements of an image forming apparatus and a process cartridge according to an embodiment of the present invention and then as to the manufacturing method of the process cartridge. A description will be provided then as to the steps of disassembling and re-assembling of the process cartridge and as to the reassembled of the process cartridge.

The remanufacturing of the process cartridge from which the toner has been used up involves disassembly of the cartridge into the toner developing container and the cleaner container, and the toner developing container is partly disassembled, and they are reassembled to provide a process cartridge having the toner developing container, which is similar in function to a new process cartridge, but has a partly different structure from a new process cartridge.

Referring to FIGS. 1 to 5, a description will be provided as to the process cartridge and an image forming apparatus to which the process cartridge is detachably mountable. A description will be provided as to the general arrangements of the process cartridge and the image forming apparatus, and then as to the structure of the cartridge frames and further as to the coupling of the frames.

(General Arrangement)

The image forming apparatus in this embodiment is an electrophotographic image forming apparatus (laser beam printer) A, as shown in FIG. 1, wherein an electrophotographic photosensitive member in the form of a drum is exposed to information light modulated in accordance with image information from an optical system 1, so that a latent image is formed on the photosensitive member, and the latent image is developed into a toner image. In synchronism with the formation of the toner image, the recording material 2 is fed out, one by one, from a sheet feeding cassette 3a using a pick-up roller 3b and a separation claws 3c press-contacted at the comers of the top surface of the recording material 2, and the sheet is fed by feeding means 3 including a feeding path 3d and a pair of registration rollers. The toner image formed on the electrophotographic photosensitive member in the process cartridge B is transferred onto the recording material 2 by applying a voltage to transfer means in the form of a transfer roller 4, and then the recording material 2 is fed to fixing means 5 on a feeding path 3f. The fixing means 5 comprises a driving roller 5a and a fixing roller 5c containing a heater 5b therein, and pressure and heat are imparted to the recording material 2, which is passing therethrough, by which the transferred toner image is fixed on the recording material. The recording material 2 is further fed by discharging rollers, and is discharged to a discharging portion 6 through a reverse feeding path.

On the other hand, the process cartridge B contains the electrophotographic photosensitive member and at least one process means. Here, the process means includes charging means for electrically charging the electrophotographic photosensitive member, the developing means for developing a latent image formed on the electrophotographic photosensitive member, and cleaning means for cleaning the surface of the electrophotographic photosensitive member to remove residual toner. As shown in FIG. 4, in the process cartridge B of this embodiment, the electrophotographic photosensitive member in the form of an electrophotographic photosensitive drum 7 having a photosensitive layer is rotated, and a voltage is applied on the charging roller 8 which is the charging means, so that the surface of the photosensitive drum 7 is uniformly charged, and the photosensitive drum 7 is exposed to a light image from the optical system 1 through an opening 9, by which an electrostatic latent image is formed, and the image is developed by developing means 10.

In the developing means 10, the toner in a toner accommodating portion 10a is fed out by feeding means in the form of a rotatable toner feeding member 10b, and a developing roller 10d containing therein a stationary magnet is rotated, by which a layer of toner particles triboelectrically charged by the developing blade 10e is formed on the surface of the developing roller 10d. The toner is selectively transferred onto the photosensitive drum 7 so that a toner image is formed. The developing roller 10d functions to supply the toner to the photosensitive drum 7. The developing blade 10e functions to regulate the thickness of the toner layer on the surface of the developing roller 10d.

The transfer roller 4 is supplied with a voltage having a polarity opposite from the polarity of the toner image, by which the toner image is transferred onto the recording material 2. Thereafter, the residual toner remaining on the photosensitive drum 7 is scraped off by the cleaning blade 11a, and the removed toner is received by a receptor sheet 11b, and the received toner is collected into a removed toner accommodating portion 11c.

(Cartridge Mounting Means)

Various parts such as photosensitive drum 7 are supported and accommodated in a cartridge frame, which is provided by coupling the toner developing container 12 and the cleaner container 13. The cartridge is mounted to the main assembly 14 of the apparatus.

In the cartridge mounting means, when the cover member 15 is opened by rotating it about the shaft 15a (FIGS. 1, 2), there are guide grooves 16 which are inclined toward the rear side at each of the left and right sides of the cartridge mounting space as shown in FIG. 2. The guide grooves 16 are disposed substantially symmetrically. The guide grooves 16 are substantially linear. At the inlet side of the guide groove 16 there is provided a positioning portion 16c (main assembly side positioning portion 16c).

On the other hand, at the opposite outer ends of the process cartridge, there are provided guide portions corresponding to the guide grooves 16 to be guided by the guide grooves 16. The guide portions are projected substantially symmetrically at the opposite longitudinal ends, respectively. As shown in FIG. 5, it comprises a boss 18 and a rib 19, which are integral. The boss 18 and the rib 19 are integrally formed with the cleaner container 13 to which the photosensitive drum 7 is mounted, and the boss 18 is disposed on an extension of a rotational axis of the photosensitive drum 7, and the rib 19 is extended from the boss 18 in an inserting direction of the process cartridge B as indicated by an arrow C in FIG. 5. The rib 19 extends inclined downwardly in conformity with the guide groove 16.

With this structure, when the process cartridge is to be mounted to the main assembly, as shown in FIG. 2, the cover member 15 is open, and the ribs 19 are engaged into the guide grooves 16, and then, the process cartridge B is inserted into the main assembly 14 of the apparatus. With the insertion, the process cartridge B makes a transnational motion, that is, a linear motion inclined downward. When the process cartridge B is further inserted, the boss 18 of the process cartridge B is seated on the main assembly side positioning portion 16c in the inlet of the guide groove 16. Simultaneously, the free end 19a of the rib 19 abuts a stopper surface 16a of the guide groove 16 by a moment about the boss 18 produced by the weight of the process cartridge B. The gravity center of the process cartridge B is at rib 19 side of the boss 18. Thus, the drum gear 51a (FIG. 5) fixed to an end of the photosensitive drum 7 is brought into meshing engagement with a driving gear 22 (FIG. 2) provided in the main assembly 14, so that a driving force can be transmitted to the process cartridge B.

Then, the cover member 15 is closed, by which the shutter opening lever 55, which is interrelated with the cover member, is rotated in the clockwise direction about the shaft 55c from a position 55a to a position 55b, so that it is engaged with a pin 28a provided on the drum shutter member 28 as shown in FIG. 10, and the drum shutter member 28 is opened about a pin 29 mounted to the cleaner container 13 against a spring force of a spring 27, thus opening a transfer opening 13n. The coil spring 27 is fitted around the pin 29, and one end thereof is engaged to the cleaner container 13, and the other end is engaged to the drum shutter member 28 and therefore, when the cover member 15 is open or when the process cartridge B is outside the main assembly 14, the drum shutter member 28 closes the transfer opening 13n by the spring force of the coil spring 27.

When the process cartridge B is to be taken out, the cover member 15 is opened, by which the shutter opening lever 55 is rotated about the shaft 55c to return from the position 55b to the position 55a. Then, drum shutter member 28 rotates about the pin 29 by the spring force of the coil spring 27, thus closing the transfer opening 13n. The process cartridge B is pulled up such that the boss 18 is away from the positioning portion 16c, and thereafter, the process cartridge B is further pulled up such that ribs 19 are guided by the guide grooves 16.

(Structure of Cartridge Frame)

A description will be provided as to the structure of the cartridge frame. The cartridge frame is made of polystyrol resin material by injection molding, and as shown in FIG. 4, a lower developing frame 12b is welded to a side of the developing device frame 12a, and a cap member 12c is welded to the upper portion, thus constituting a toner developing container 12. A cap member 13b is welded to a top of a cleaning frame 13a to constitute an integral cleaner container 13. Then, the cleaner container 13 is coupled with the toner developing container 12 to constitute a cartridge frame.

The developing device frame 12a is provided at an end thereof with a toner supply opening 12a1, as shown in FIG. 13, 14, and is also provided at one longitudinal end with a toner filling opening 12a2. The developing device frame 12a is provided therein with a plurality of erected supporting members (not shown) in the longitudinal direction. The toner supply opening 12a1 permits the supply of the toner from the toner accommodating portion 10a to the developing roller 10d. The toner in the toner accommodating portion 10d is supplied to the developing roller 10d through the toner supply opening 12a1.

When the developing means is mounted in place, as shown in FIGS. 4 and 13, a toner feeding member 10b is mounted in the developing device frame 12a, and thereafter, the cap member 12c is welded to the developing device frame 12a. Subsequently, a toner seal 31 in the form of a film is welded on a surface 12a5 of the seat formed around the circumference of the toner supply opening 12a1 of the toner developing container 12 to seal the opening 12a1. Then, the toner is filled through the toner filling opening 12a2, and thereafter, the filling opening 12a2 is plugged by a cap 32 to seal the toner accommodating portion 10a. The toner seal 31 sealing the toner supply opening 12a1, as shown in FIG. 13, is folded back at one longitudinal end of the opening 12a1, and the free end thereof is extended out through a slit 12a8 of the developing device frame 12a. The free end of the toner seal 31 is nipped by fingers of the user and is pulled out when the user starts to use the process cartridge B.

When it is pulled out, the sealing is not complete at the portion where the toner seal 31 extends through the toner developing container 12.

Therefore, as shown in FIG. 13, an elastic sealing material 10h, such as a felt, is provided in the slit 12a8 at an end closer to the free end of the toner seal 31.

As shown in FIG. 13, the elastic sealing material 10h is overlaid on the toner seal 31 and urges the toner seal 31. Therefore, when the toner seal 31 is pulled out, the elastic sealing material 10h occupies the slit 12a8 that has been occupied by the toner seal 31 to be press-contacted to a wall of the developing device frame 12a, thus preventing leakage of the toner to the outside.

A description will be provided as to the mounting of the elastic sealing material 10h. As shown in FIG. 15, a part of the arcuate portion 12a6 of the developing device frame 12a is provided with an angle groove 12a26 extending in the longitudinal direction. The bottom of the angle groove 12a26 is flush with the toner seal sticking seat surface 12a5. An elastic sealing material 10h, such as a felt or the like, is stuck on a piece 10j engaged in the angle groove 12a26.

With this structure, even when the toner seal 31 is pulled out, the toner is prevented from leaking to the outside of the toner developing container 12 through the slit 12a8.

Then, the lower developing frame 12b is welded to the developing device frame 12a. As shown in FIG. 8, the developing device frame 12a is provided at the opposite longitudinal ends of the toner supply opening 12a1 with arcuate portions 12a6 at which the end seals 34 are to be mounted. A flat flange 12a16 is extended between the arcuate portions 12a6 below the seal sticking seat surface 12a5, and the flange 12a16 is substantially perpendicular to the seal sticking seat surface 12a5. On the other hand, lower developing frame 12b is engaged with the longitudinally opposing surfaces of the arcuate portions 12a6. Therefore, in consideration of manufacturing errors, the lower developing frame 12b has a length that is smaller than the distance between the opposing surfaces of the arcuate portion 12a6 by $2 \times g$, where g is a gap at each end. The flange 12a16 is provided with holes 12a17, and the lower developing frame 12b is provided with dowels 12b3 for engagement with the holes 12a17, respectively. With the dowels 12b3 being in engagement with the respective hole 12a17, the bottom surface of the lower developing frame 12b and the top surface of the flange 12a16 of the developing device frame 12a are welded to each other. By doing so, a gap g is formed between the arcuate portion 12a6 and the lower developing frame 12b at each end. The dimension of the gap g is not constant when the lower developing frame 12b is fixed to the developing device frame 12a.

When the lower developing frame 12b is engaged with the developing device frame 12a, a sealing material 39, such as a felt, is inserted between the developing device frame 12a and each of the longitudinal opposite ends of the lower developing frame 12b.

Each of the opposite ends of the lower developing frame 12b is provided with an outward projection 12b2 (FIG. 8). The developing device frame 12a is provided at each of the end portions with a recess 12a18 for engagement with a projection 12b2 when the dowels 12b3 are engaged with the holes 12a17 for the purpose of welding or bonding of the lower developing frame 12b. As shown in FIG. 20, a gap $g1$ is provided between the recess 12a18 and the projection 12b2. The gap is substantially equal to the gap g formed between the lower developing frame 12b and the arcuate portion 12a6.

As shown in FIG. 8, the arcuate portion 12a6 of the developing device frame 12a is provided with a sticking portion 12a20 to which the end seal 34 is stuck. The sticking portion 12a20 has an arcuate peripheral surface having a common axis with the arcuate portion 12a21 provided longitudinally outside of the arcuate portion 12a6. The axis is the rotational axis of the developing roller 10d in the toner developing container 12. The sticking portion 12a20 is provided with an arcuate surface having a radius that is smaller than that of the outer arcuate portion 12a21. An end of the sticking portion 12a20, as shown in FIG. 8, ends short of (inside) the circumference of the outer arcuate portion 12a21.

As shown in FIGS. 17, 18, 19, when the lower developing frame is welded to or bonded to the developing device frame 12a, a slit 12d is provided between the arcuate portion 12a6 and the lower developing frame 12b.

The slit 12d, as shown in FIGS. 21 to 23, is on an optical path of a laser beam passing through a gap (development gap) formed between the photosensitive drum 7 and the developing roller 10d provided by the spacer roller 10d1, which is disposed to each of the opposite end portions of the photosensitive drum 7 and the developing roller 10d. The optical path passes through the slit 12d, a slit 10e6 provided in the metal blade 10e2, and a hole 13b1 formed in the cap member 13b.

In FIG. 21, the laser beam emitted from the laser source 86 has a width that is larger than the gap (approximately 300 μ m) between the photosensitive drum 7 and the developing roller 10d. The laser beam emitted from the laser source 86 travels through the hole 13b1, the slit 10e6, the gap between the photosensitive drum 7, and the developing roller 10d and the slit 12d, and is then received by a photoreceptor 87. The width of the laser beam received by the photoreceptor 87 is measured in a direction parallel with the face of the sheet of the drawing of FIG. 21. Therefore, the development gap can be detected.

The measurement of the gap between the photosensitive drum 7 and the developing roller 10d using the laser beam is effected at each of opposite longitudinal ends of the photosensitive drum 7 (two positions). Therefore, the hole 13b1, and the slits 10e6, 12d are each provided at at least two positions (adjacent opposite longitudinal ends).

After the lower developing frame 12b is welded to the developing device frame 12a, the end seal 34 and the seal 35 are mounted.

As shown in FIG. 16, the end seal 34 functions to provide a seal between the developing device frame 12a and each of the end portions of the developing blade 10e and each of the end portions of the developing roller 10d, and it comprises an arcuate portion 34a contactable to the developing roller

10d along its circumferential surface and an integral linear portion **34b** along a rear surface of each of the end portions of the metal blade **10e2**. The outer circumference of the arcuate portion **34a** is stuck to the sticking portion **12a20** of the developing device frame **12a**.

As shown in FIG. 4, a seal **35** of urethane foam or the like is mounted and extended between blade mounting seat surfaces **12a4** formed above the toner discharging opening **12a1** of the toner discharging, and the developing blade **10e** is screwed on the blade mounting seat surface **12a4** with the seal **35** therebetween. By doing so, the seal **35** is compressed between the metal blade **10e2** and a developing device frame **12a** so that sealing is accomplished between the metal blade **10e2** and the developing device frame **12a**.

The development holder **36** shown in FIGS. 16, 24 is secured to one of the ends of the developing device frame **12a**, and the development holder **37** shown in FIGS. 16, 25 is secured to the other end thereof. The development holders **36, 37** are fixed to the developing device frame **12a** by small screws **56, 57**.

The shaft **10d2** of the developing roller **10d** at one end is engaged with a fixed bearing **33b**, which is in the form of a shaft integral with the development holder **37** shown in FIGS. 15, 16. The developing roller shaft **10d 2** is received by a bearing hole **33a 2** of the bearing **33a** at the other end of the developing roller **10d**, and as shown in FIG. 15, a hole **33a4** is engaged with a positioning dowel **12a7** provided on the developing device frame **12a** at an outside of one of the longitudinal ends. Then, the developing roller gear **10f** is engaged with the developing roller shaft **10d2**. The engaging portion **33a3** of the bearing **33a** is engaged with a part-cylindrical engaging portion **36a** of the development holder **36**. At this time, the developing roller gear **10f** is accommodated in the development holder **36**. A small screw **56** is penetrated through a hole **36c** of the development holder **36**, and a hole **33a1** of the bearing **33a** and is threaded into a female screw **12a13** of the developing device frame **12a**. The gear accommodating portion **36b** outside the development holder **36** is part-cylindrical, and when the toner developing container **12** and a cleaner container **13** are coupled, the developing roller gear **10f** is brought into meshing engagement with the drum gear **51** through the open part of the gear accommodating portion **36b**.

Each of the development holders **36, 37** is provided with an integral arm portion **38** functioning as a connecting portion for connecting the toner developing container **12** and the cleaner container **13**.

The toner developing container **12** having the various members constituting the developing means and the cleaner container **13** having the various members constituting the photosensitive drum **7**, the charging roller **8**, and a cleaning means are coupled by the arm portions **38** to constitute the process cartridge B.

(Coupling Between Toner Developing Container and Cleaner Container)

Referring to FIGS. 7, 11, 24, 25, 26, a description will be provided as to the coupling between the toner developing container **12** and the cleaner container **13**. FIGS. 7 and 11 are a side view and a perspective view, respectively, illustrating the coupling between the containers **12, 13**; FIG. 26 shows the inside of the coupling portion; and FIGS. 24, 25 are side views of the other end portion of the toner developing container **12**. The containers **12, 13** are rotatably coupled through the arms **38** at the opposite ends. Since the covering structures at the left and right ends are substantially the same, a description will be provided as to only one end. However, the portions which are different between the left and right ends will be described for the respective ends.

As shown in FIGS. 11 and 24, the developing device frame **12a** is provided with an integral spring mounting portion **12a28**, on which a compression coil spring **40** is mounted. The position of the compression coil spring **40** is adjacent one of the longitudinal ends of the developing device frame **12a**, and is away from the arm portion **38** in a direction perpendicular to the longitudinal direction. The compression coil spring **40** extends out in parallel with the arm portion **38**. At a free end portion of the arm portion **38** at the longitudinal end where the compression coil spring **40** is provided, a through-hole **38b** is provided for receiving a pin **41**, which will be described hereinafter. As shown in FIG. 26, an outer wall **13q** of the cleaner container **13** is provided with a hole **13c** for receiving the pin **41**, and an inner wall **13d** thereof is provided with a hole **13e** for being press-fitted by the pin **41**. The hole **13c** and the hole **13e** are aligned along a line parallel with the photosensitive drum **7**. An elongated bore **38b1** is formed in the arm portion **38** and the other end of the cleaner container **13**, and a line connecting the center of the elongated bore **38b1** and the hole **38b** passes through the centers of the holes **13c, 13e**. The elongated bore **38b1** is elongated in a direction parallel with a line connecting the center of the photosensitive drum **7** and the center of the developing roller **10d**, and the width of the elongated bore **38b1** is equal to the diameter of the pin **41**.

When the toner developing container **12** and the cleaner container **13** are coupled together with each other, as shown in FIGS. 7 and 11, the arm portion **38** of the toner developing container **12** is inserted into the recess **13h** of the cleaner container **13**, and the pin **41** is penetrated through the hole **13c, 13c** of the cleaner container **13**, the through hole **38b** of the arm portion **38**, and the elongated bore **38b1** in the order named, and is press-fitted into the hole **13e, 13e** of the inner wall **13d**. By doing so, the toner developing container **12** and the cleaner container **13** are rotatably coupled for rotation about the pin **41**. At this time, the compression coil spring **40** mounted to the developing device frame **12a** is compressed out the abutment to the spring seat **13f** (FIG. 26) of the cleaner container **13**. The photosensitive drum **7** and the developing roller **10d** are urged toward each other about the pin **41** so that spacer rollers **10d1** of the developing roller **10d** are press-contacted to the photosensitive drum **7**.

Because of the provision of the elongated bore **38b1**, the photosensitive drum **7** and spacer rollers **10d1** of the developing roller **10d** contact each other at the generating lines thereof. The generating lines are parallel with the center lines of the photosensitive drum **7** and the developing roller **10d**.

FIG. 7 shows an end surface portion that is opposite from the end where the compression coil spring **40** is provided. Opposite ends of a tension coil spring **59** are engaged with a spring hook **13p** of the cleaner container **13** and a spring hook **12a29** of the developing device frame **12a** of the toner developing container **12**, respectively. The direction of the tension coil spring **59** is substantially parallel with a line connecting the centers of the photosensitive drum **7** and the developing roller **10d**.

By doing so, by the compression coil spring **40** and the tension coil spring **59**, the developing roller **10d** mounted in the toner developing container **12** is urged toward the photosensitive drum **7** mounted in the cleaner container **13**, so that spacer rollers **10d1** at the opposite longitudinal ends of the developing roller **10d** contact the photosensitive drum **7**, by which the developing roller **10d** is correctly positioned relative to the photosensitive drum **7**. The drum gear **5** la fixed to the end of the photosensitive drum **7** is brought into

meshing engagement with the developing roller gear **10f** fixed to the end of the developing roller **10d**, so that a driving force can be transmitted.

(Remanufacturing of Process Cartridge)

Embodiment 1

(Separating Step Between Toner Developing Container and Cleaner Container)

The tension coil spring **59** shown in FIG. 7 is disengaged from the spring hook **13p** of the cleaner container **13**.

By doing so, the force between the photosensitive drum **7** and the developing roller **10d** is provided only by the compression coil spring **40**. Therefore, the toner developing container **12** and the cleaner container **13** are rotatable relative to each other about the pin **41**.

Then, the pin **41** is removed. This is done by pulling out the pin **41** using a pleyer or the like if the pin **41** is projected out of the process cartridge B. If not, the pin **41** is pushed into the process cartridge to disengage it.

Thus, the container separating step is completed, by which the toner developing container **12** comprising the toner accommodating portion **10a**, the toner supply opening **12a1**, the developing roller **10d** and the developing blade **10e**, and the cleaner container **13** comprising the photosensitive drum **7**, are separated from each other by disengaging the pins **41** at one and the other longitudinal ends of the process cartridges B. FIG. 11 shows the thus separated toner developing container **12** and cleaner container **13**.

(Removing Step of Developing roller)

As shown in FIG. 28, the separated toner developing container **12** includes the developing roller **10d** and the developing blade **10e** mounted thereto.

First, the development holders **36**, **37** fixed to the opposite end of the developing device frame **12a** are removed. The small screw **56** fastening the development holder **36** and the bearing **33a** to the developing device frame **12a**, as shown in FIG. 15, is removed, and the development holder **36** is moved longitudinally outwardly. Then, the developing roller gear **10f** is pulled off the developing roller shaft **10d2**. The bearing **33a** supporting the developing roller **10d** is removed from the shaft **10d2** of the developing roller **10d**. The developing roller **10d** is pulled in the actual direction to remove it from the bearing **33b** of the development holder **37**, and the developing roller **10d** is removed from the toner developing container **12**.

By doing so, the developing roller dismounting step is completed, by which the developing roller **10d** mounted to the toner developing container **12** is removed. FIG. 14 shows a state in which the developing roller **10d** has been removed. When the gear train **61** (FIG. 25) for driving the toner feeding member **10b** is to be inspected, the development holder **37** is removed from the developing device frame **12a** by removing the small screw **57**.

(Dismounting Step of Developing Blade)

After the developing roller **10d** has been removed, the developing blade **10e** is removed. The developing blade **10e** is removed by unthreading the small screws **10e4**, which fixes the developing blade **10e** to the blade mounting seat surface **12a4** of the developing device frame **12a** as shown in FIG. 14, and then moving the developing blade **10e** away from the blade mounting seat surface **12a4**.

Thus, the developing blade dismounting step is completed, by which the developing blade **10e** mounted to the toner developing container **12** is separated by the separation step. FIG. 17 is a top plan view showing the toner developing device frame **12a** from which the developing blade **10e** has been removed. FIG. 29 shows the removed developing blade **10e** (except for the side pad **65**).

Here, all the elements that should be removed from the toner developing device frame **12a** have been removed. The drum shutter member **28** is not removed by these actions, but is retained.

(Application of Sealing Material for Toner Developing Container)

If the toner seal **31** is restored, there manufactured process cartridge is substantially the same as a new process cartridge. According to the invention, the toner seal **31** is not repaired or restored. Even without the toner seal **31**, it will suffice if the toner does not leak when the developing means is mounted to the toner developing container.

(End Seal)

Each or one of the end seals **34** is replaced with a new one if it is confirmed as being damaged after inspection.

(Filling Sealing Material into Gap Between Developing device Frame and Lower Developing Frame)

Between the developing device frame **12a** and the lower developing frame **12b**, the gap **g** extends along the inner surface of the end seal **34** at each of the end portions. The gap **g** is in the form of a crank extending toward the gap **g1** as shown in FIG. 20, as seen from an outside of the toner developing container **12**.

First, the gaps **g** and **g1** are sealed. This sealing is effected by continuously sticking a developing container cover side seal **62**, which has an adhesive tape on an outer periphery of the lower developing frame **12b** and the arcuate portion **12a6** as shown in FIG. 20 (hatching line) and FIGS. 30, 32. The sealing covers the entire length of the gaps **g** and **g1** and also covers the slit **12d**.

Then, the gap **g** is filled with a sealing material **64**. The sealing material **64** is supplied from the inner side of the arcuate portion **12a6**. When the sealing material **64** is filled into the gap **g**, the sealing material **64** is injected into the gap **g** at a position which is substantially in the middle of the length of the gap using a tool (unshown), and thereafter the sealing material **64** is expanded toward one and the other ends of the length of the gap **g**, thus filling the sealing material **64** into the gap **g** along its full length.

The sealing material **64** is plastically deformable. Examples of such sealing material **64** includes polymeric materials having a curing property or polymeric materials having a thermoplastic property. The sealing materials include a silicon bond, which is polymeric material having a silicone-bonding-material curing property. The polymeric material having a thermoplastic property includes hot-melt plastic resin material.

When the silicon bond is used as the sealing material **64**, for example, the sealing material is filled, and it is left for approximately 6 hours, and the cover side seal **62** is removed after it is dried.

(Sticking of Side Pad)

As shown in FIG. 33, a gap **S** exists between the longitudinal end of the elastic blade **10e1** of the developing blade **10e** and the end seal **34**. During the image forming operation, the toner does not leak out in the longitudinal direction by the provisions of the end seal **34** despite the existence of the gap **S**. However, during transportation, the toner is liable to leak out, since the corner portion between the end seal **34** and a seal **35** is a linear portion **34b** of the end seal **34**, so that it is not in close contact with the developing roller **10d**. Therefore, a side pad is provided.

As shown in FIG. 29, a side pad **65** (seal) is stuck on the longitudinal surface of the elastic blade **10e1** of the developing blade **10e** at each of the opposite end portions so as to extend beyond the longitudinal end of the blade.

The pad is stuck on the backside of the elastic blade **10e1**, that is, the side not facing the developing roller **10d**, using

an adhesive material. The side pad **65** has such a size that it is compressed into the corner formed by the end seal **34** and a seal **35**, so that it is contacted to them by its elasticity, and one side is substantially leveled with the free end of the elastic blade **10e1**.

When the developing roller **10d** is mounted, the side pad **65** provides sealing between the end seal **34** and the end of the elastic blade **10e1**. The side pad **65** is press-contacted to the end seal **34** and to the seal **35**.

By doing so, during transportation, the toner is prevented from leaking out through between the developing device frame **12a** and the developing blade **10e** at the opposite ends of the developing roller **10d**.

The side pad **65** is mounted on the reused developing blade **10e** if the developing blade **10e** is reusable. When the developing blade **10e** is to be replaced with a new part, the new part developing blade **10e** is already provided with the side pad **65**.

In this example, the side pad **65** is made of an elastic material such as a sponge.

(End Lateral Seal)

A jaw seal sticking seat surface **12b5** (FIG. 4) of the lower developing frame **12b** after a jaw seal (blow-preventing seal) **42** is stuck, is a flat surface, and an extension surface thereof is lower than the extension of the arcuate surface of the inner surface (the surface contacting to the developing roller **10d**) of the arcuate portion **34a** of the end seal **34**. That is, the jaw seal sticking seat surface **12b5** is not flush with the upper surface of the end seal **34**. Therefore, when the jaw seal **42** is stuck, a gap remains between the counterpart of the seal **42** at the longitudinal end thereof. The counterpart member is the sealing material **64** having sealed the gap *g*.

Therefore, an end lateral seal **66** of an elastic member is mounted against the end seal **34** provided at each of one and the other inside longitudinal ends of the developing roller **10d** and at the opposite side from the side where the toner accommodating portion **10a** is provided.

FIG. 35 shows an end lateral seal developed into a plane. FIG. 36 is a sectional view taken along a line A—A. For the purpose of easy understanding, gaps are shown between members. Actually, however, the members shown in FIG. 36 are contacted without gaps. As shown in figure, the end lateral seal **66** is stuck to the lower developing frame **12b** at the corners of the sealing material **64** and the end seal **34**, by adhesive material. As will be described hereinafter, the jaw seal **42** is stuck usually first in the remanufacturing process. By doing so, the end lateral seal **66** is closely contacted to the end seal **34**, the sealing material **64** and the lower developing frame **12b**. The gap *S1* among the jaw seal **42**, the lower developing frame **12b** and an end lateral seal **66** is reduced by the side cover seal **69** and is sealed from the outside.

As shown in FIGS. 36, 43, the opposite ends of the jaw seal **42** are overlaid on the end lateral seal **66** and the end seal **34**.

With the above-described process, the sealing is provided between the jaw seal **42** and an end seal **34**.

(Seal for Slit for Developing Gap Measurement)

As described in the foregoing, the toner sealing is quite completely accomplished by the sealing material **64**, the side pad **65**, the end lateral seal **66**, and the seal **42**. However, if the toner were passed through between the jaw seal **42** and the end lateral seal **66**, the toner might reach the slit **12d** provided in order to assure the optical path for the measurement of the development gap. In view of this, a seal is provided to prevent the toner having reached the slit **12d** from leaking out.

FIG. 37 is a front view of the cut-away portion constituting the slit **12d** as seen in a direction perpendicular to the longitudinal direction of a developing roller **10d**. As shown in FIG. 38, the jaw groove filling seal **68** fills substantially the entire width of the cut-away portion **12d**.

The process will be described. As shown in FIGS. 37, 40, 41, a double-coated adhesive tape or the like is stuck on one surface **68b** of a relatively thin rectangular sealing material **68a**, and it is stuck on the end of the sealing material **64**, the wool felt portion **34c** of the end seal **34**, and the bottom of the cut-away portion **12d** substantially flush therewith. The end seal **34** comprises a felt portion **34c** and a sliding portion **34d** thereon, which is made of fibers having a small friction coefficient.

The sealing material **68a** is bent by 90° from a corner AAA where the arcuation of the arcuate portion **12a6** ends (FIG. 41) toward the outside, by which the slit **12d** is substantially closed, as shown in FIG. 38. However, the complete closure of the slit is not intended. As shown in FIG. 41, if the upper portion of one surface **68b** of the sealing material **68a** is partly overlapped with the end of the end seal **34**, the toner may pass through between the end lateral seal **66** and the jaw seal **42** to reach the slit **12d**. It will suffice if the leakage of such toner is prevented, and therefore, as shown in FIG. 40, a gap *g2* may be provided between the lateral wall **12d1** of the cut-away portion **12d** and the sealing material **38a** (side cover seal **69** which will be described hereinafter).

(Mounting of Jaw Seal)

After mounting various seals described in the foregoing, the jaw seal **42** is stuck on the seat surface **12b5**. As shown in FIGS. 42, 43, the jaw seal **42** is stuck. The opposite longitudinal ends of the jaw seal **42** ride on the associated end seals **34** and are bonded thereto by adhesive material. As shown in FIG. 45, the free end, extending in the longitudinal direction of the process cartridge, of the jaw seal **42** is pressed against the developing roller codirectionally with respect to the peripheral movement of the surface of the developing roller. (In this embodiment, the new cartridge is not provided with the jaw seal, since the toner in the developer container is confined therein by the seal **31**.)

(Side Cover Seal)

A side cover seal is provided for the purpose of back-up and toner-leakage prevention at a portion where the bent portion of the jaw groove filling seal **68** and end portions of the jaw seal **42** are overlapped with the end lateral seal **66**.

As shown in FIG. 44, such a surface of the arcuate portion **12a6** of the developing device frame **12a** as is not facing the developing roller **10d**, is provided with a rib **12a36**. The lower developing frame **12b** is provided with a rib **12b6** which is parallel with the rib **12a36** with the longitudinal gap *g* between the lower developing frame **12b** and the arcuate portion **12a6** of the developing device frame **12a** disposed between the ribs. The side cover seal **69** has a width which is equal to the gap between the ribs **12a36** and **12b6**. The side cover seal **69** is stuck and extended from a position CC at a free end (in the direction of a width, that is, perpendicular to the longitudinal direction) of the flange **12a16** (FIGS. 4 and 8) of the developing device frame **12a** and the cover of the developing device frame **12a** and the gap *g* in the form of a crank, is then folded back over the free end portion D to embrace the groove filling seal **68** and the jaw seal **42** end as shown in FIG. 45. By doing so, the jaw seal **42** at a longitudinal extension of the jaw seal sticking seat surface **12b5** of the lower developing frame **12b** is closely contacted to the jaw groove filling seal **68**, and the jaw seal **42** is not easily removed from the sticking seat surface **12b5** at an edge of a side surface of the seal **68**.

(Mounting of Developing Blade)

When a developing device frame **12a** is deformed, for example, a gap is produced between the metal blade **10e2**. Here, the seal **35** is long, and therefore, the sealing property is relatively not very good. In view of this, a re-assembling of this embodiment will be described according to which the performance of the toner developing container **12** is substantially the same as a new one.

A seal is provided in addition to the seal **35** in consideration of the case that the sealing property of the seal **35** of the toner developing container **12** is deteriorated.

The developing blade **10e** having been removed is subjected to simultaneous air suction and air blowing, or the like such that deposited toner is removed from the blade to clean it.

Then, the developing blade **10e** is inspected to determine whether it is reusable or not. If the result of the inspection indicates that the performance thereof is lower than a predetermined standard, it is replaced with a new one.

Between the blade mounting seat surfaces **12a4** at the opposite ends of the developing device frame **12a**, a flange is provided, which is provided with a mounting seat **12a3**.

The bent portion **10e3** of the metal blade **10e2** of the developing blade **10e** shown in FIG. **16** is urged toward the seat **12a3** of the flange of the developing device frame **12a** with the seal **35** compressed therebetween, and the holes **10e7** of the metal blade **10e2** are fitted around the positioning dowels **12a11** provided on the developing blade mounting seat surface **12a4**. Then, a small screw **10e4** (only one longitudinal end portion of the metal blade **10e2** is shown) is threaded into the developing blade mounting seat surface **12a4** through the hole **10e7** provided adjacent each of the opposite longitudinal ends of the metal blade **10e2** so that the developing blade **10e** is fixed to the developing device frame **12a**.

This is the end of the developing blade mounting step to mount the developing blade to the separated toner developing container **12**.

(Developing Roller Mounting Step)

The developing roller **10d** that has been removed is subjected to air suction and simultaneous air blowing or another process to clean it by removing the deposited toner.

Then, the the developing roller **10d** is inspected, and it is determined whether or not it is reusable. If the determination is negative, that is, the performance does not satisfy a predetermined reference, the developing roller is replaced with a new one.

The developing roller **10d** may be worn due to friction with the developing blade **103**. Therefore, when the statistical probability that replacement is necessary on the basis of the inspections during development thereof or remanufacturing thereof, the developing roller may be replaced with a new one without inspection, and by doing so, the remanufacturing operation is efficient.

In the inspection of the developing roller **10d**, it is disassembled into the main body of the developing roller, the magnet **10c**, the bearings **33a**, **33b**, spacer rollers **10d1**, a roller electrode (unshown), the developing roller gear **10f**, and so on are inspected, respectively, to find reusable parts. The non-reusable parts are replaced with new ones.

As for the gear train **61** for driving the toner feeding member **10b** rotatably supported on the developing device from **12a** and the lower developing frame **12b**, the development holder **37** is removed, and the gear train is cleaned and inspected, and is replaced with usable parts, and they are reassembled prior to the assembling of the used or new developing roller **10d**.

Referring to FIGS. **15** and **16**, the process of mounting the developing roller **10d** to the toner developing container **12** will be described.

The development holder **37** is engaged to the developing device frame **12a**. A small screw **57** is threaded into the developing device frame **12a** through the development holder **37** so that the development holder **37** is fixed to the developing device frame **12a**. Then, a journal hole at an end of the developing roller **10d** is engaged with a bearing **33b** of the development holder **37**. Subsequently, at a longitudinal end that is opposite from the bearing **33b**, the bearing **33a** is engaged in the journal at the other end of the developing roller **10d**, and the bearing **33a** is aligned with the developing device frame **12a**. A D-shaped shaft portion is provided at the journal end of the developing roller **10d** projected outwardly beyond the bearing **33a**, and the developing roller gear **10f** has a hole that has the complementary shape and size. Then, the engaging portion **36a** of the development holder **36** is engaged with a cylindrical engaging portion **33a3** of the bearing **33a**. At this time, one end of the magnet **10c** is engaged with a D-shaped hole **36d** which is provided longitudinally outwardly beyond the bearing hole. The shaft portion at the end of the magnet **10c** has a complementary shape and size with the D-shaped hole **36d**. Then, a small screw **56** is threaded into a female screw **12a13** of the developing device frame **12a** through the hole **36c** of the development holder **36** and the hole **33a1** of the bearing **33a**. By doing so, the development holders **37**, **36** are fixed to the developing device frame **12a**, and the developing roller **10d** is supported by the toner developing container.

This is the end of the process of mounting the developing roller **10d** to the separated toner developing container **12**.

The toner developing container **12** to which the developing roller **10d** is mounted is shown in FIG. **11**. A new toner developing container **12** and a remanufactured toner developing container **12** are the same as seen in FIG. **11**. (Developing Blade Top Seal)

If the toner developing container **12**, particularly, the surface on which the seal **35** is stuck, is deformed during transportation, a gap is formed between the metal blade **10e2** and the seal **35**. So, there is a risk that toner leaks between the longitudinal end edge of the metal blade **10e2** and the developing device frame **12a**.

In view of this, as shown in FIG. **46**, a seal is stuck on the outside of the toner developing device frame **12a** over the metal blade **10e2** and the cap member **12c**. The seal is called here a blade top seal **49**. As shown in FIG. **29**, a scraper **60** is fixed to the metal blade **10e2**. The free end **60a** of the scraper **60** contacts the developing roller **10d** by its elastic force. The free end **60a** is inclined relative to the generating line of the developing roller **10d**.

The free end **60a** is downstream with respect to the peripheral movement of the developing roller **10d** toward the longitudinal inside direction. By this arrangement, the toner deposited on the developing roller **10d** is prevented from moving in the longitudinally outward direction, so that toner returns from the end of the jaw seal **42** into between the jaw seal **42** and the developing roller **10d**.

A longitudinal end of the blade top seal **49** stuck on the metal blade **10e2** and the cap member **12c** such that it closes the gap between the metal blade **10e2** and the cap member **12c** in the longitudinal direction, is within a range where the scraper **60** exists.

By this arrangement, the seal sticking step, for sticking the seal for preventing the toner from leaking, over the metal blade portion of the developing blade **10e** and the toner developing container **12**, is completed.

The seal sticking step may be carried out immediately after the developing blade **10e** is mounted to the toner developing container **12**.

The blade top seal **49** is an adhesive tape.
(Toner Filling Step)

Toner is filled into the toner developing device frame **12a** which has been sealed at various positions described above, through the toner filling opening **12a2**, and a toner cap **32** or plug is press-fitted into the toner filling opening **12a2** to seal it.

In an alternative of the method, the toner may be filled before the developing blade **10e** and the developing roller **10d** are remounted. In such a case, as shown in FIG. **56**, the toner developing container **12** is placed with the toner supply opening **12a1** face up and the toner accommodating portion **10a** at a lower position. A free end of a funnel **47** is inserted into the opening **12a1**, and the toner falls from the toner bottle **48** onto the funnel **47**. After the toner filling, the developing blade **10e** and the developing roller **10d** are remounted in the same manner as in the case described above. A metering supplying device provided with an auger may preferably be provided in the funnel, since then the toner can be efficiently supplied.

Thus, the toner filling step into the toner accommodating portion **10a** through the toner supply opening **12a1** is completed.

The toner does not leak out through the gap **g** in the form of a crank at the end portions of the developing device frame **12a** and the lower developing frame **12b** because of the sealing material **64** provided as described hereinbefore.

The toner end lateral seal **66** is effective to prevent leakage that may otherwise occur between the jaw seal (blow-out preventing seal) **42** and the end seal **34**.

In addition to the end lateral seal **66**, the jaw groove filling seal **68** is effective to seal the end of the end seal **34**, and further, the side cover seal **69** is effective to back up the sealing function of the jaw seal **42** and the end seal **34**, so that toner leakage is further prevented.

Moreover, a side pad **65** stuck on the elastic blade **10e1** of the developing blade **10e** contacts the corner formed between the seal **35** and the end seal **34**, and therefore, the longitudinal end of the elastic blade **10e1** is closely contacted to the developing roller **10d**, and is sealed by the side pad **65**, and the toner is prevented from leaking out of the longitudinal ends of the elastic blade **10e1**.

Therefore, no toner leaks out of the inside of the toner developing container **12** having the developing roller **10d** and the developing blade **10e** during normal transportation and handling.

(Coupling of Toner Developing Container and Cleaner Container)

The coupling step for the toner developing container **12** and the cleaner container **13** is similar to the coupling step for the toner developing container **12** and the cleaner container **13** having the toner seal. Therefore, a description thereof will be made in conjunction with FIGS. **11,7,26**.

In FIG. **11**, the arm portions **38** of the toner developing container **12** are inserted into the recesses **13h** of the cleaner container **13**. As shown in FIG. **26**, the through hole **38b** and the elongated bore **38b1** of the arm portion **38** are aligned with the holes **13c** on the outer wall surface **13q** of the cleaner container **13**. When the hole **13c** and the through hole **38b** and the elongated bore **38b1** are aligned, the through hole **38b** and the elongated bore **38b1** are aligned with the holes **13e** in the surface **13d** of the inner wall of the cleaner container **13**. Then, the pin **41** is inserted through the holes **13c** of the cleaner container **13** and the hole **38b** and

the elongated bore **38b1** of the arm portion **38** of the toner developing container **12**. Further, the pin **41** is press-fitted into the hole **13e** in the inner wall of the cleaner container **13**. As shown in FIG. **7**, the end portions of the tension coil spring **59** are hooked on the spring hook **12a29** of the toner developing container **12** and the spring hook **13p** of the cleaner container **13**, thereby stretching the tension coil spring **59**. By this, the photosensitive drum **7** is press-contacted to the spacer rollers **10d1** at the end portions of the developing roller **10d**.

In this manner, the remanufacturing of the process cartridge is possible without remounting of the toner seal **31**.
(Remanufacturing of Cleaner Container)

During the remanufacturing of the toner developing container **12**, the separated cleaner container **13** is remanufactured.

FIG. **11** is a perspective view showing the cleaner container **13** having the photosensitive drum **7**, the charging roller **8**, and the cleaning blade **11a**. FIG. **47** is a longitudinal sectional view wherein the photosensitive drum **7** is mounted to the cleaner container **13**. FIG. **48** shows a structure for supporting the charging roller **8** on the cleaner container **13**.

As shown in FIG. **47**, the photosensitive drum **7** is provided at one end of the drum cylinder **7a** (hollow aluminum cylinder) having a photosensitive layer thereon with a flange **51** and is provided at the other end with a flange **52**. The flanges are fixed to the drum by bonding or crimping. The flange **51** is provided with a drum gear **51a**. The flange **52** has a transfer roller driving gear **52a**. The drum shafts **53a**, **53b** penetrating the flanges **51**, **52**, are received by holes **13k**, **13m** of the cleaner container **13** and are supported by the cleaner container **13**. When the process cartridge B is mounted to the main assembly **14** of the image forming apparatus, the drum gear **51a** is brought into meshing engagement with the driving gear **22** of the main assembly **14** of the image forming apparatus shown in FIG. **2**, and the transfer roller driving gear **52a** is brought into meshing engagement with the unshown gear fixed to the transfer roller **4**. When the coupling between the cleaner container **13** and the toner developing container **12** is completed, the drum gear **51a** is engaged with the developing roller gear **10f** of the developing roller **10d**.

As shown in FIG. **48**, the charging roller **8** comprises a metal shaft **8a** and a rubber roller thereon having an intermediate resistance, and the metal shaft **8a** is exposed at the end portions.

As shown in FIG. **48**, the shaft **8a** of the charging roller **8** is rotatably engaged in charging roller bearings **8c** which are slidably engaged in the guide groove **13g** extending substantially on a line connecting the centers of the photosensitive drum **7** and the charging roller **8**. The charging roller bearing **8c** is urged toward the photosensitive drum **7** by the compression coil spring portion **8b**, which is compressed between the charging roller bearing **8c** and the spring seat **13s** at one end of the guide groove **13g**, so that the charging roller **8** is press-contacted to the photosensitive drum **7**. The charging roller **8** is driven by the photosensitive drum **7**. The compression coil spring **8b** is held in the bearing **8c**.

An unshown electrode contacts the metal shaft **8a** of the charging roller **8**, and is extended to an outside of the process cartridge B. The outer contact portion of the electrode is electrically connected with a contact portion of the main assembly **14** of the image forming apparatus, which is connected with an outer contact portion in the main assembly.

The cleaning blade **11a**, as shown in FIG. 4, comprises a metal blade **11a2** and an elastic blade **11a1** of rubber or the like fixed to the metal blade **11a2** and contacting the photosensitive drum **7** along a generating line thereof. As shown in FIG. 4, the cleaning blade **11a** is fixed to the cleaner container **13** by threading a small screw **11a4** through a hole at the end portions of the metal blade **11a2**.

A description will be provided as to dismounting of the photosensitive drum **7**, the charging roller **8** and the photosensitive drum **7** from the cleaner container **13**.

The photosensitive drum **7** is dismounted from the cleaner container **13** when the shafts **53a**, **53b** are pulled out of the center holes **51b**, **52b** of the flanges **51**, **52**, shown in FIG. 47.

When the photosensitive drum **7** is dismounted, the charging roller **8** is moved in a direction perpendicular to its axis, so that bearings **8c** are moved along the guide groove **13g**, by which the bearing **8c** is dismounted from the guide groove **13g** together with the charging roller **8**. The bearing **8c** is disengaged from the shaft **8a**, and the compression coil spring **8b** is dismounted. In this manner, an opening G between the cleaning blade **11a** and the receptor sheet **11b** and extending in the longitudinal direction appears (FIG. 4).

The removed photosensitive drum **7**, the charging roller **8c** and the bearings **8c**, are subjected to inspections to determine whether to reuse them or not, and if they should be reused, they are assembled into the cleaner container **13** in the reassembling operation which will be described hereinafter, and if not, a new part or parts are used. Usually, however, the photosensitive drum **7** has such a long lifetime that it is still usable at the time when the toner is used up. (Removal of Residual Toner in Cleaner Container)

The residual toner in the cleaner container **13** is removed after the photosensitive drum **7**, the charging roller **8**, the bearing **8c** and the like are removed.

Referring to FIGS. 49, 50, 51, a description will be provided as to the removal of the toner contained in the removed toner accommodating portion **11c** of the cleaner container **13**.

FIG. 49 shows a cleaning device for the cleaner container. The cleaner container **13** is set in a casing **70a** of the cleaning device **70**. The casing **70a** seals the inside against the atmosphere. The cleaner container **13** is impacted by an impacting device **77** that is carried on the pivoting device **73**, and the residual toner is sucked out of the set by a suction device **79**. Simultaneously, the cleaner container **13** is swung about a shaft **76b** by a swing device **73**.

FIG. 50 shows details of an air block **79a** of the suction device **79**. The air block **79a** is generally hollow, and has a close contact surface **79g** to be contacted to the edge of the opening G of the cleaner container **13**, the close contact surface **79g** being coated with a rubber-like seal member **79b** except for the ejection opening **79d** and the suction opening **79e**. An air supply tube **79c** for supplying the air into the cleaner container **13** is disposed in the air block **79a**, and an air blow opening **79d** opens adjacent a longitudinal end of the above-described close contact surface **79g**. Furthermore, a suction tube **79f** is disposed in the air block **79a**, and the suction opening **79e** of the suction tube **79f** is disposed adjacent the other end of the close contact surface **79g**. The close contact surface **79g** having the air blow opening **79d** and the suction opening **79e** is contacted to the cleaning blade **11a** and the receptor sheet **11b** of the cleaner container **13** that has been moved in the direction of arrow **K3** to a cleaning position **M2** by a table **72**, so that in the opening G between the edges of them is completely covered. This is indicated by chain lines in the opening G in FIG. 50 and

more particularly, by the sealing range **A1**, the air blowing opening **A2**, and the air discharging outlet **A3**. The sealing range **A1**, the air blowing opening **A2**, and the air discharging outlet **A3** correspond to the close contact surface **79g**, the air blow opening **79d** and the suction opening **79e**, respectively. In the suction device **79**, compressed air **Q1** is supplied into the cleaner container **13** closely contacted to the air block **79a** from the air supply tube **79c** through the air blow opening **79d** closely contacted to the air blowing opening **A2** and through the opening G (arrow **Q2**) to scatter the residual toner; and the residual toner and the air are sucked from the cleaner container **13** through the suction opening **79e** closely contacted to the air discharging outlet **A3** (arrow **Q3**) into the suction tube **79f** (arrow **Q4**).

The residual toner leaked out of the air block **79a** and cleaner container **13**, is sucked by an auxiliary suction device (unshown) with the atmosphere in the suction device **75** through the ambience suction opening **78**, as shown in FIG. 49.

Referring to FIGS. 49 and 50 and a flow chart of FIG. 51, a description will be provided as to the cleaning method of the cleaner container **13** and the operation of the cleaning device **70** in detail.

The operation of the cleaning device (cleaner) **70** is started at step (S1). Then, the cleaner container **13** to be cleaned is placed on the top of a table **72**, which is at a home position at this time (S2). The cover **70b** is closed (S3), which event is detected by a sensor (door switch) **70d** (S4), and an air cylinder of a clamping device (unshown) is actuated (S5), by which the top side of the cleaner container **13** is pushed.

By this, the cleaner container **13** is clamped on the table **72** at a predetermined position. It is then determined whether the clamping is OK (S6). If not, the method returns to step S5. If so, an air cylinder **75** having a piston rod directly connected to the table **72** is actuated (S7), so that table **72** moves from the home position **M1** on the slide base **71** to a cleaning position **M2** in the swing device **73** (S8), and the opening G of the cleaner container **13** is closely contacted to the surface **79g** of the suction device **79**.

Then, a motor **77a** is actuated (S9), and the impacting device **77** is started, by which the pin **77b** of the crank to which the shaft of the motor **77a** is fixed is swung about a pin **77d** supporting the yoke **77c**. Impact is applied to a point P (FIG. 50) on the top side of the cleaner container **13** by a hammer **77g** fixed to an end of the leaf spring arm **77e** fixed to the yoke **77c** (S10). By doing so, the residual toner deposited on the inner wall of the cleaner container **13** is forced to fall, and the mobility of the residual toner is enhanced. A rotary actuator **76** is started (S11), and the swing table **73a** of the swing device **73** reciprocates about a shaft **76b** swingably supporting the swing table **73a** within the range of $\alpha=0-80^\circ$ (S12). The swing table **73a** is stopped by abutting stoppers **71a**, **71b**, the positions of which are adjustable. A stop valve (unshown) for the compressed air is opened (S13, S14) to supply the compressed air into the cleaner container **13** through the air blow opening **79d** (FIG. 50) and the opening G, and simultaneously, the air in the cleaner container **13** is sucked through the opening G and the suction opening **79e** together with the residual toner. The operation is continued for a proper period.

The swing table **73a** is swung through one reciprocation (S15). A rotary actuator **76** is deactivated (S16), and the horizontal position **N1** of the swing table **73a** is checked (S17), and then, the motor **77a** is deactivated (S18, S19), so that the impact imparted by the hammer to the position **N1** ends. The stop valve is closed (S20, S21). The air cylinder **75** is urged in the resetting direction (S22), and then, the

table 72 located at the cleaning position M2 is returned to the home position M1, which is then checked (S23). In positive response, an unshown clamping air cylinder is deactivated (S24) and the clamp of the cleaner container 13 relative to the table 72 is released (S25). Then, the cover 70b is opened 5 (S26), and the cleaner container 13 is taken out of the casing 70a (S27). Next, it is determined whether the cleaning of the next cleaner container is to occur (S28). If so, the process returns to step S2. If not, the cleaning operation ceases (S29). This is the end of the cleaning operation for the cleaner container 13. 10

In the cleaning step, the impact to the cleaner container 13 by the device 77 continues in the period between the steps S9 and S18 in the flow chart of FIG. 51, and contemporaneously therewith, the swing action of the cleaner container 13 and the suction of the residual toner are carried out. Thus, the residual toner deposited on the inner wall or the like of the cleaner container 13 is beaten out, and the residual toner is smoothly moved toward the opening G. The compressed air blown out from the air blow opening 79d is effective to scatter around in the cleaner container 13, and the residual toner is sucked from the suction opening 79e. By the series of the operations, the residual toner can be substantially completely removed from the cleaner container 13. 15

After the cleaning, the cleaning blade 11a is removed from the cleaner container 13 by unthreading the small screw 11a4 (FIG. 4). Then, the receptor sheet 11b is removed from the cleaner container 13. Then, while sucking the air from the inside of the cleaner container 13, compressed air is blown into the cleaner container 13, thus cleaning the inside of the cleaner container 13. Thereafter, a new receptor sheet 11b is stuck on the cleaner container 13. Holes 11a3 of a new cleaning blade 11a at the end portions (FIG. 11 shows only one of the end portions) are brought into engagement with the positioning projections 13i of the cleaner container 13, and small screw 11a4 is threaded into the cleaner container 13 through the hole of the metal blade 11a2. 20

Then, a charging roller 8 engaged with the bearings 8c to which the compression coil springs 8b are mounted, is mounted on the shaft 8a. This is done by engaging the bearing 8c into the guide groove 13g with the compression coil spring 8b at the leading side. Thereafter, as shown in FIG. 47, the photosensitive drum 7 is engaged between the end walls of the cleaner container 13, and the center holes 51b, 52b of the flanges 51, 52 are aligned with holes 13k, 13m 25 in the end walls at the opposite ends of the cleaner container 13, and then, the drum shafts 53a, 53b are engaged into the holes 13k, 51b, 52b, 13m. The drum shafts 53a, 53b are press-fitted in the holes 13m, 13k, and the drum shafts 53a, 53b are slidably engaged in the holes 51b, 52b. The photosensitive drum 7 in the unit is rotatable on the drum shafts 53a, 53b. 30

(Gap between Photosensitive Drum and Developing Roller)

When the photosensitive drum 7 and the developing roller 10d contact each other, the drum gear 51a and the developing roller gear 10f are in meshing engagement with each other. When the process cartridge is transported with the drum gear 51a and the developing roller gear 10f are in meshing engagement with each other, the tooth surfaces of the gears are in contact, and therefore, they may be rotated by impact or vibration. If the direction of the rotation is as indicated by an arrow AAA in FIG. 52 (the same direction as in the image forming operation), there is no problem. However, the direction of the rotation is not assured, since the vibration or the impact during the transportation occurs at random. If the photosensitive drum 7 rotates in the direction indicated by an arrow BBB, that is, if the photo- 35

sensitive drum 7 and the developing roller 10d are rotated in the direction opposite from the normal direction, the toner may be leaked out through between the jaw seal 42 (blow-out preventing sheet) and the developing roller 10d, and in the worst-case, the seal 42 may be wound around the developing roller since the preventing sheet is contacted to the developing roller counter-directionally. In addition, the scraper 60 mounted to each of the opposite ends of the developing blade 10e and functioning to guide the toner inwardly at the opposite ends of the developing roller 10d can operate correctly when the developing roller 10d rotates in the normal direction, and therefore, if it is rotated in the wrong direction, the toner may leak out at the opposite ends of the developing roller 10d. 40

In this embodiment, the back clearance of the meshing between the drum gear 51a and the developing roller gear 10f is made larger than that during the image formation to avoid abutment between the tooth surfaces during transportation. Another alternative is to disengage them for transportation. 45

Referring to FIG. 54, a description will be provided as to means for maintaining the disengaged state or large back clearance between the drum gear 51a and the developing roller gear 10f. In the case of FIG. 53, a tape 81 is stuck over the toner developing container 12 and the cleaner container 13 with the drum gear 51a and the developing roller gear 10f disengaged from each other or with the large back clearance. 50

More particularly, a force is applied to bias the toner developing container 12 and the cleaner container 13 toward each other and at positions across a vertical surface passing through a point P which is a pivot between the toner developing container 12 and the cleaner container 13 from the portion where the photosensitive drum 7 and the developing roller 10d are provided, as indicated by an arrow N in FIG. 53, by which the back clearance between the drum gear 51a and the developing roller gear 10f is increased, or they are disengaged from each other. The force is against the spring force provided by the tension coil spring 59 (FIG. 7) and the compression coil spring 40 (FIG. 11) for urging the photosensitive drum 7 and the developing roller 10d toward each other. Therefore, the tape 81 is stretched by the springs 40, 59. Therefore, the tape 81 has sufficient width and thickness such that stress during the transportation is within a tolerable range, and in addition, the adhesive material or the adhesive material for the tape has also sufficient bonding strength against the toner developing device frame 12a and the cleaner container 13. 55

The foregoing embodiments are summarized as follows.

1. A remanufacturing method of remanufacturing a process cartridge B comprising:

(a) a step of preparing a used process cartridge B which comprises a toner developing container 12, a cleaning container 13 and pins for coupling the toner developing container 12 and the cleaning container 13 at opposite longitudinal ends of the process cartridge B;

the toner developing container 12 including a toner accommodating portion 10a, a toner supply opening 12a1, a developing roller 10d, and a developing blade 10e;

the cleaning container 13 including an electrophotographic photosensitive drum 7;

(b) a container separating step of separating the process cartridge B into the toner developing container 12 and the cleaning container by disengaging the pins from the process cartridge B;

(c) a blade seal 49 mounting step of mounting a blade seal 49 between a blade mounting plate 10e2 and an outside of a toner developing frame to seal a gap between the blade mounting plate 10e2 and the toner developing frame; 60

- (d) a toner refilling step of refilling the toner into the toner accommodating portion **10a** of the toner developing container **12** having the blade seal **49**; and
- (e) a container coupling step of coupling the toner developing container **12** having the blade seal **49** with the cleaning container **13** by engaging the pin **41** into them. 5
2. A method according to Paragraph **1**, wherein the developing blade **10e** is a new or used blade.
3. A method according to Paragraph **1** or **2**, further comprising: 10
- a developing roller **10d** dismounting step of dismounting the developing roller **10d** from the toner developing container **12** separated by the container separating step;
 - a developing blade **10e** dismounting step of dismounting the developing blade **10e** from the toner developing container **12** separated by the container separating step; 15
 - and
 - a sealing material filling step of filling a sealing material in a gap formed in said toner developing container **12** and extending along an inner side of an end seal **34** provided adjacent each of longitudinal ends of the developing roller **10d**. 20
4. A method according to Paragraph **1** or **2**, further comprising: 25
- a developing roller **10d** dismounting step of dismounting the developing roller **10d** from the toner developing container **12** separated by the container separating step;
 - a developing blade **10e** dismounting step of dismounting the developing blade **10e** from the toner developing container **12** separated by the container separating step; 30
 - and
 - an elastic member **66** mounting step of mounting an elastic member **66** longitudinally inside of an end seal **34** provided adjacent each of opposite longitudinal ends of the developing roller **10d**, at a position laterally outside of the end seal **34**. 35
5. A method according to Paragraph **1** or **2**, further comprising: 40
- a developing roller **10d** dismounting step of dismounting the developing roller **10d** from the toner developing container **12** separated by the container separating step;
 - a developing blade **10e** dismounting step of dismounting the developing blade **10e** from the toner developing container **12** separated by the container separating step; 45
 - and
 - a cut-away portion **12d** sealing step of sealing a cut-away portion **12d** formed in the toner developing container **12** adjacent each of opposite longitudinal ends of the developing roller **10d**, at a position laterally outside of the end seal **34**. 50
6. A remanufacturing method of remanufacturing a process cartridge B comprising: 55
- (a) a step of preparing a used process cartridge B which comprises a toner developing container **12**, a cleaning container **13** and pins for coupling the toner developing container **12** and the cleaning container **13** at opposite longitudinal ends of said process cartridge B;
 - the toner developing container **12** including a toner accommodating portion **10a**, a toner supply opening **12a1**, a developing roller **10d** and a developing blade **10e**; 60
 - the cleaning container **13** including an electrophotographic photosensitive drum **7**;
 - (b) a container separating step of separating the process cartridge B into the toner developing container **12** and 65

- the developing container by disengaging the pins from the process cartridge B;
 - (c) a developing roller **10d** dismounting step of dismounting the developing roller **10d** from the toner developing container **12** separated by the container separating step;
 - (d) a developing blade **10e** dismounting step of dismounting the developing blade **10e** from the toner developing container **12** separated by the container separating step;
 - (e) a sealing material filling step of filling a sealing material in a gap formed in the toner developing container **12** and extending along an inner side of an end seal **34** provided adjacent each of longitudinal ends of the developing roller **10d**;
 - (f) an elastic member **66** mounting step of mounting an elastic member **66** longitudinally inside of an end seal **34** provided adjacent each of opposite longitudinal ends of the developing roller **10d**, at a position laterally outside of the end seal **34**;
 - (g) a cut-away portion **12d** sealing step of sealing a cut-away portion **12d** formed in the toner developing container **12** adjacent each of opposite longitudinal ends of the developing roller **10d**, at a position laterally outside of the end seal **34**;
 - (h) a developing blade **10e** mounting step of mounting the developing blade **10e** on the toner developer container;
 - (i) a blade seal **49** mounting step of mounting a blade seal **49** between a blade mounting plate **10e2** and an outside of a toner developing frame to seal a gap between the blade mounting plate **10e2** and the toner developing frame;
 - (j) a developing roller **10d** mounting step of mounting the developing roller **10d** on the toner developer container;
 - (k) a toner refilling step of refilling the toner into the toner accommodating portion **10a** of the toner developing container **12** having the blade seal **49**; and
 - (l) a container coupling step of coupling the toner developing container **12** having the blade seal **49** with the cleaning container **13** by engaging the pin **41** into them.
7. A remanufacturing method of remanufacturing a process cartridge B comprising: 70
- (a) a step of preparing a used process cartridge B which comprises a toner developing container **12**, a cleaning container **13** and pins for coupling the toner developing container **12** and the cleaning container **13** at opposite longitudinal ends of the process cartridge B;
 - the toner developing container **12** including a toner accommodating portion **10a**, a toner supply opening **12a1**, a developing roller **10d**, and a developing blade **10e**;
 - the cleaning container **13** including an electrophotographic photosensitive drum **7**;
 - (b) a container separating step of separating the process cartridge B into the toner developing container **12** and the cleaning container by disengaging the pins from the process cartridge B;
 - (c) a developing roller **10d** dismounting step of dismounting the developing roller **10d** from the toner developing container **12** separated by the container separating step;
 - (d) a developing blade **10e** dismounting step of dismounting the developing blade **10e** from the toner developing container **12** separated by the container separating step;
 - (e) a sealing member mounting step of mounting a sealing member on a side of the developing blade **10e** which is away from the developing roller **10d** adjacent each of opposite longitudinal ends thereof;

- (f) a developing blade **10e** mounting step of mounting the developing blade **10e** on the toner developer container;
- (g) a developing roller **10d** mounting step of mounting the developing roller **10d** on the toner developer container;
- (h) a toner refilling step of refilling the toner into the toner accommodating portion **10a** of the toner developing container **12** having the blade seal **49**; and
- (i) a container coupling step of coupling the toner developing container **12** having the blade seal **49** with the cleaning container **13** by engaging the pin **41** into them.

8. A method according to Paragraph 7, wherein the sealing member is an elastic member **66**.

9. A method according to Paragraph 6 or 7, further comprising a sealing material filling step of filling a sealing material in a gap formed in the toner developing container **12** and extending along an inner side of an end seal **34** provided adjacent each of longitudinal ends of the developing roller **10d**.

10. A method according to Paragraph 6 or 7, further comprising an elastic member **66** mounting step of mounting an elastic member **66** longitudinally inside of an end seal **34** provided adjacent each of opposite longitudinal ends of the developing roller **10d**, at a position laterally outside of the end seal **34**.

11. A method according to Paragraph 6 or 7, further comprising a cut-away portion **12d** sealing step of sealing a cut-away portion **12d** formed in the toner developing container **12** adjacent each of opposite longitudinal ends of the developing roller **10d**, at a position laterally outside of the end seal **34**.

12. A remanufacturing method of remanufacturing a process cartridge B comprising:

- (a) a step of preparing a used process cartridge B which comprises a toner developing container **12**, a cleaning container **13** and pins for coupling the toner developing container **12** and the cleaning container **13** at opposite longitudinal ends of the process cartridge B;

the toner developing container **12** including a toner accommodating portion **10a**, a toner supply opening **12a1**, a developing roller **10d**, and a developing blade **10e**;

the cleaning container **13** including an electrophotographic photosensitive drum **7**;

- (b) a container separating step of separating the process cartridge B into the toner developing container **12** and the cleaning container by disengaging the pins from the process cartridge B;

(c) a developing roller **10d** dismantling step of dismantling the developing roller **10d** from the toner developing container **12** separated by the container separating step;

(d) a developing blade **10e** dismantling step of dismantling the developing blade **10e** from the toner developing container **12** separated by the container separating step;

(e) a sealing material filling step of filling a sealing material in a gap formed in the toner developing container **12** and extending along an inner side of an end seal **34** provided adjacent each of longitudinal ends of the developing roller **10d**;

(f) an elastic member **66** mounting step of mounting an elastic member **66** longitudinally inside of an end seal **34** provided adjacent each of opposite longitudinal ends of the developing roller **10d**, at a position laterally outside of said end seal **34**;

(g) a cut-away portion **12d** sealing step of sealing a cut-away portion **12d** formed in the toner developing container **12** adjacent each of opposite longitudinal

ends of the developing roller **10d**, at a position laterally outside of the end seal **34**;

- (h) a sealing member mounting step of mounting a sealing member on a side of the developing blade **10e** which is away from the developing roller **10d** adjacent each of opposite longitudinal ends thereof;

(i) a developing blade **10e** mounting step of mounting the developing blade **10e** on the toner developer container;

(j) a blade seal **49** mounting step of mounting a blade seal **49** between a blade mounting plate **10e2** and an outside of a toner developing frame to seal a gap between the blade mounting plate **10e2** and the toner developing frame;

(k) a developing roller **10d** mounting step of mounting the developing roller **10d** on the toner developer container;

(l) a toner refilling step of refilling the toner into the toner accommodating portion **10a** of the toner developing container **12** having the blade seal **49**; and

(m) a container coupling step of coupling toner developing container **12** having the blade seal **49** with said cleaning container **13** by engaging the pin **41** into them.

13. A method according to Paragraph 12, further comprising a blade seal **49** mounting step of mounting a blade seal **49** between a blade mounting plate **10e2** and an outside of a toner developing frame to seal a gap between the blade mounting plate **10e2** and the toner developing frame.

14. A method according to any one of Paragraphs 1 to 12, wherein the remanufacturing method is implemented with a toner seal for sealing a toner supply opening **12a1** provided to supply the toner accommodated in the toner accommodating portion **10a** to the developing roller **10d** having been pulled out to supply the toner accommodated in the toner accommodating portion **10a** to the developing roller **10d**.

15. A method according to any one of Paragraphs 1, 6, 7 and 12, wherein the process cartridge B comprises a gear fixed co-axially with the electrophotographic photosensitive drum **7** and a gear fixed co-axially with the developing roller **10d**, which gears are in meshing engagement, and wherein after the container coupling process, the toner developing container **12** and the cleaner container are rotated about the pin **41** to disengage the gears from each other or to make a back clearance of the meshing engagement larger than that during image forming operation, and the disengagement or larger back clearance is maintained.

16. A method according to Paragraph 15, wherein the toner developing container **12** and the cleaner container are rotated toward each other about the pin **41** at a portion across the pin **41** from electrophotographic photosensitive drum **7**, and a tape is stuck on the toner developing container **12** and the cleaner container to maintain the disengagement or the larger back clearance.

According to the present invention, an easy remanufacturing method is provided for process cartridges, and an easy remanufacturing method is provided for process cartridges with which the toner leakage can be effectively prevented.

While the invention has been described with reference to the structures disclosed herein, it is not confined to the details set forth and this application is intended to cover such modifications or changes as may come within the purpose of the improvements or the scope of the following claims.

What is claimed is:

1. A remanufacturing method of remanufacturing a process cartridge comprising:

- (a) a step of preparing a used process cartridge which comprises a toner developing container, a cleaning container, and pins for coupling said toner developing

- container and said cleaning container at opposite longitudinal ends of said process cartridge;
- said toner developing container including a toner accommodating portion, a toner supply opening, a developing roller, and a developing blade;
- said cleaning container including an electrophotographic photosensitive drum;
- (b) a container separating step of separating said process cartridge into said toner developing container and said cleaning container by disengaging said pins from said process cartridge;
- (c) a blade seal mounting step of mounting a blade seal between a blade mounting plate and an outside of a toner developing frame to seal a gap between said blade mounting plate and said toner developing frame;
- (d) a toner refilling step of refilling the toner into said toner accommodating portion of said toner developing container having said blade seal; and
- (e) a container coupling step of coupling said toner developing container having said blade seal with said cleaning container by engaging said pins into them.
2. A method according to claim 1, wherein said developing blade is a new or used blade.
3. A method according to claim 1 or 2, further comprising:
- a developing roller dismantling step of dismantling said developing roller from said toner developing container separated by said container separating step;
- a developing blade dismantling step of dismantling said developing blade from said toner developing container separated by said container separating step; and
- a sealing material filling step of filling a sealing material in a gap formed in said toner developing container and extending along an inner side of an end seal provided adjacent each of longitudinal ends of said developing roller.
4. A method according to claim 1 or 2, further comprising the steps of:
- a developing roller dismantling step of dismantling said developing roller from said toner developing container separated by said container separating step;
- a developing blade dismantling step of dismantling said developing blade from said toner developing container separated by said container separating step; and
- an elastic member mounting step of mounting an elastic member longitudinally inside of an end seal provided adjacent each of opposite longitudinal ends of said developing roller, at a position laterally outside of said end seal.
5. A method according to claim 1 or 2, further comprising the steps of:
- a developing roller dismantling step of dismantling said developing roller from said toner developing container separated by said container separating step;
- a developing blade dismantling step of dismantling said developing blade from said toner developing container separated by said container separating step; and
- a cut-away portion sealing step of sealing a cut-away portion formed in said toner developing container adjacent each of opposite longitudinal ends of said developing roller, at a position laterally outside of an end seal.
6. A remanufacturing method of remanufacturing a process cartridge comprising:
- (a) a step of preparing a used process cartridge which comprises a toner developing container, a cleaning

- container, and pins for coupling said toner developing container and said cleaning container at opposite longitudinal ends of said process cartridge;
- said toner developing container including a toner accommodating portion, a toner supply opening, a developing roller, and a developing blade;
- said cleaning container including an electrophotographic photosensitive drum;
- (b) a container separating step of separating said process cartridge into said toner developing container and said cleaning container by disengaging said pins from said process cartridge;
- (c) a developing roller dismantling step of dismantling said developing roller from said toner developing container separated by said container separating step;
- (d) a developing blade dismantling step of dismantling said developing blade from said toner developing container separated by said container separating step;
- (e) a sealing material filling step of filling a sealing material in a gap formed in said toner developing container and extending along an inner side of an end seal provided adjacent each of longitudinal ends of said developing roller;
- (f) an elastic member mounting step of mounting an elastic member longitudinally inside of said end seal provided adjacent each of opposite longitudinal ends of said developing roller, at a position laterally outside of said end seal;
- (g) a cut-away portion sealing step of sealing a cut-away portion formed in said toner developing container adjacent each of opposite longitudinal ends of said developing roller, at a position laterally outside of said end seal;
- (h) a developing blade mounting step of mounting said developing blade on said toner developing container;
- (i) a blade seal mounting step of mounting a blade seal between a blade mounting plate and an outside of a toner developing frame to seal a gap between said blade mounting plate and said toner developing frame;
- (j) a developing roller mounting step of mounting said developing roller on said toner developing container;
- (k) a toner refilling step of refilling the toner into said toner accommodating portion of said toner developing container having said blade seal; and
- (l) a container coupling step of coupling said toner developing container having said blade seal with said cleaning container by engaging said pins into them.
7. A remanufacturing method of remanufacturing a process cartridge comprising:
- (a) a step of preparing a used process cartridge which comprises a toner developing container, a cleaning container, and pins for coupling said toner developing container and said cleaning container at opposite longitudinal ends of said process cartridge;
- said toner developing container including a toner accommodating portion, a toner supply opening, a developing roller, and a developing blade;
- said cleaning container including an electrophotographic photosensitive drum;
- (b) a container separating step of separating said process cartridge into said toner developing container and said cleaning container by disengaging said pins from said process cartridge;
- (c) a developing roller dismantling step of dismantling said developing roller from said toner developing container separated by said container separating step;

- (d) a developing blade dismounting step of dismounting said developing blade from said toner developing container separated by said container separating step;
- (e) a sealing member mounting step of mounting a sealing member on a side of said developing blade which is away from said developing roller adjacent each of opposite longitudinal ends thereof;
- (h) a developing blade mounting step of mounting said developing blade on said toner developing container;
- (i) a developing roller mounting step of mounting said developing roller on said toner developing container;
- (j) a toner refilling step of refilling the toner into said toner accommodating portion of said toner developing container having a blade seal; and
- (k) a container coupling step of coupling said toner developing container having said blade seal with said cleaning container by engaging said pins into them.

8. A method according to claim 7, wherein said sealing member is an elastic member.

9. A method according to claim 7, further comprising a sealing material filling step of filling a sealing material in a gap formed in said toner developing container and extending along an inner side of an end seal provided adjacent each of longitudinal ends of said developing roller.

10. A method according to claim 7, further comprising an elastic member mounting step of mounting an elastic member longitudinally inside of an end seal provided adjacent each of opposite longitudinal ends of said developing roller, at a position laterally outside of said end seal.

11. A method according to claim 7, further comprising a cut-away portion sealing step of sealing a cut-away portion formed in said toner developing container adjacent each of opposite longitudinal ends of said developing roller, at a position laterally outside of an end seal.

12. A remanufacturing method of remanufacturing a process cartridge comprising:

- (a) a step of preparing a used process cartridge which comprises a toner developing container, a cleaning container, and pins for coupling said toner developing container and said cleaning container at opposite longitudinal ends of said process cartridge; said toner developing container including a toner accommodating portion, a toner supply opening, a developing roller, and a developing blade; said cleaning container including an electrophotographic photosensitive drum;
- (b) a container separating step of separating said process cartridge into said toner developing container and said cleaning container by disengaging said pins from said process cartridge;
- (c) a developing roller dismounting step of dismounting said developing roller from said toner developing container separated by said container separating step;
- (d) a developing blade dismounting step of dismounting said developing blade from said toner developing container separated by said container separating step;

- (e) a sealing material filling step of filling a sealing material in a gap formed in said toner developing container and extending along an inner side of an end seal provided adjacent each of longitudinal ends of said developing roller;
- (f) an elastic member mounting step of mounting an elastic member longitudinally inside of said end seal provided adjacent each of opposite longitudinal ends of said developing roller, at a position laterally outside of said end seal;
- (g) a cut-away portion sealing step of sealing a cut-away portion formed in said toner developing container adjacent each of opposite longitudinal ends of said developing roller, at a position laterally outside of said end seal;
- (h) a sealing member mounting step of mounting a sealing member on a side of said developing blade which is away from said developing roller adjacent each of opposite longitudinal ends thereof;
- (i) a developing blade mounting step of mounting said developing blade on said toner developing container;
- (j) a developing roller mounting step of mounting said developing roller on said toner developing container;
- (k) a toner refilling step of refilling the toner into said toner accommodating portion of said toner developing container having said blade seal; and
- (l) a container coupling step of coupling said toner developing container having said blade seal with said cleaning container by engaging said pins into them.

13. A method according to any one of claims 1, 2, 6, 7, 8, and 12, wherein said remanufacturing method is implemented with a toner seal for sealing said toner supply opening provided to supply the toner accommodated in said toner accommodating portion to said developing roller having been pulled out to supply the toner accommodated in said toner accommodating portion to said developing roller.

14. A method according to any one of claims 1, 6, 7 and 12, wherein said process cartridge comprises a gear fixed co-axially with said electrophotographic photosensitive drum and a gear fixed co-axially with said developing roller, which gears are in meshing engagement, and wherein after said container coupling process, said toner developing container and said cleaning container are rotated about said pins to disengage said gears from each other or to make a back clearance of the meshing engagement larger than that during an image forming operation, and the disengagement or larger back clearance is maintained.

15. A method according to claim 14, wherein said toner developing container and said cleaning container are rotated toward each other about said pins at a portion across said pins from said electrophotographic photosensitive drum, and a tape is stuck on said toner developing container and said cleaning container to maintain the disengagement or the larger back clearance.

UNITED STATES PATENT AND TRADEMARK OFFICE
CERTIFICATE OF CORRECTION

PATENT NO. : 6,473,577 B1
DATED : October 29, 2002
INVENTOR(S) : Higeta et al.

Page 1 of 3

It is certified that error appears in the above-identified patent and that said Letters Patent is hereby corrected as shown below:

Title page,

Item [57], **ABSTRACT,**

Line 1, "remanufacturing" should read -- remanufacturing --.

Column 1,

Line 53, "with" should read -- of --.

Column 2,

Line 41, "filing" should read -- filling --.

Column 3,

Line 66, "filing" should read -- filling --.

Column 4,

Line 7, "said" should be deleted.

Line 8, "the" should read -- the end --.

Column 6,

Line 24, "of the" should be deleted.

Line 52, "and a" should read -- and --.

Line 53, "comers" should read -- corners --.

Column 8,

Line 6, "transnational" should read -- translational --.

Column 9,

Line 41, "12through the slit 12a8" should read -- 12 through the slit 12a8. --

Column 11,

Line 23, "10d 2" should read -- 10d2 --.

Line 24, "33a 2" should read -- 33a2 --.

Line 41, "51 a" should read -- 51a --.

Column 12,

Line 66, "5 1a" should read -- 51a --.

Column 13,

Line 16, "plyer" should read -- pair of pliers --.

UNITED STATES PATENT AND TRADEMARK OFFICE
CERTIFICATE OF CORRECTION

PATENT NO. : 6,473,577 B1
DATED : October 29, 2002
INVENTOR(S) : Higeta et al.

Page 2 of 3

It is certified that error appears in the above-identified patent and that said Letters Patent is hereby corrected as shown below:

Column 14,

Line 7, "there" should read -- the --.

Line 40, "includes" should read -- include --.

Column 15,

Line 38, "a end" should read -- an end --.

Column 17,

Line 43, "the the" should read -- the --.

Column 19,

Line 40, "comer" should read -- corner --.

Column 20,

Line 29, "5 1a." should read -- 51a. --.

Column 21,

Line 5, "11ais" should read -- 11a is --.

Line 18, "if" should read -- is --.

Column 23,

Line 55, "51 a" should read -- 51a --.

Line 58, "are" should be deleted.

Column 24,

Line 22, "51a" should read -- 51 a --.

Line 32, "10 dare" should read -- 10d are --.

Line 46, "remanufacturing" should read -- remanufacturing --.

Column 25,

Line 52, "remanufacturing" should read -- remanufacturing --.

Column 26,

Line 40, "remanufacturing" should read -- remanufacturing --.

Column 27,

Line 31, "remanufacturing" should read -- remanufacturing --.

UNITED STATES PATENT AND TRADEMARK OFFICE
CERTIFICATE OF CORRECTION

PATENT NO. : 6,473,577 B1
DATED : October 29, 2002
INVENTOR(S) : Higeta et al.

Page 3 of 3

It is certified that error appears in the above-identified patent and that said Letters Patent is hereby corrected as shown below:

Column 28,

Line 51, "disengage mentor" should read -- disengagement or --.

Signed and Sealed this

Fifth Day of August, 2003

A handwritten signature in black ink, appearing to read "James E. Rogan", with a horizontal line drawn underneath it.

JAMES E. ROGAN
Director of the United States Patent and Trademark Office