



US006445433B1

(12) **United States Patent**  
**Levola**

(10) **Patent No.:** **US 6,445,433 B1**  
(45) **Date of Patent:** **\*Sep. 3, 2002**

(54) **PIXEL STRUCTURE HAVING DEFORMABLE MATERIAL AND METHOD FOR FORMING A LIGHT VALVE**

6,002,661 A 12/1999 Abe et al. .... 369/112  
6,147,789 A 11/2000 Gelbart ..... 359/231

**OTHER PUBLICATIONS**

(75) Inventor: **Tapani Levola**, Tampere (FI)  
(73) Assignee: **Nokia Corporation**, Espoo (FI)  
(\* ) Notice: Subject to any disclaimer, the term of this patent is extended or adjusted under 35 U.S.C. 154(b) by 25 days.

W. Brinker et al., "Deformation Behavior of Thin Viscoelastic Layers used in an Active-Matrix-Addressed Spatial Light Modulator", vol. 1018, Electro-Optic and Magneto-Optic Materials, 1988 pp. 79-85.  
R. Tepe et al., "Viscoelastic Spatial Light Modulator with Active Matrix Addressing", vol. 28, No. 22., Applied Optics, Nov. 15, 1989, pp. 4826-4834.  
Y. Hoshino et al., "Light Modulation by Transverse Electric Field Induced Oil Surface Deformation" Appl. Phys. Lett. 55, Sep. 11, 1989.

This patent is subject to a terminal disclaimer.

*Primary Examiner*—William L. Sikes  
*Assistant Examiner*—Dung Nguyen  
(74) *Attorney, Agent, or Firm*—Cohen, Pontani, Lieberman & Pavane

(21) Appl. No.: **09/596,622**  
(22) Filed: **Jun. 19, 2000**

**Related U.S. Application Data**

(63) Continuation-in-part of application No. 09/570,197, filed on May 12, 2000, which is a continuation-in-part of application No. 09/443,822, filed on Nov. 19, 1999.  
(51) **Int. Cl.**<sup>7</sup> ..... **G02F 1/1335**  
(52) **U.S. Cl.** ..... **349/113; 349/149; 359/231**  
(58) **Field of Search** ..... **349/113, 149; 359/231, 292**

(57) **ABSTRACT**

A light valve capable of operating in an "off" state for reflecting light and in an "on" state for diffracting and reflecting light. The valve includes a semiconductor substrate having a plurality of electrodes formed therein for receiving voltages and for generating an electric field in response to the received voltages. A layer of transparent deformable dielectric material is disposed on the reflective electrodes which deforms in response to the generated electric field. When the valve is in its "on" state, the electric field causes deformities in the dielectric material which diffract incident light reflected off of the valve. In another embodiment, the dielectric material is placed on the reflective electrodes or on a transparent substrate having a transparent electrode formed thereon. The transparent substrate is then disposed in spaced relation from the semiconductor substrate containing the reflective electrodes.

(56) **References Cited**

**U.S. PATENT DOCUMENTS**

3,084,590 A	4/1963	Glenn, Jr. ....	88/1
3,385,927 A	5/1968	Hamann .....	178/7.5
3,882,271 A	5/1975	Glenn .....	178/7.3
4,519,682 A	5/1985	Mast .....	353/122
4,641,193 A	2/1987	Glenn .....	358/233
5,124,834 A	6/1992	Cusano et al. ....	359/291
5,521,747 A	5/1996	Engle .....	359/292
5,760,755 A	6/1998	Engle .....	345/85

**13 Claims, 6 Drawing Sheets**

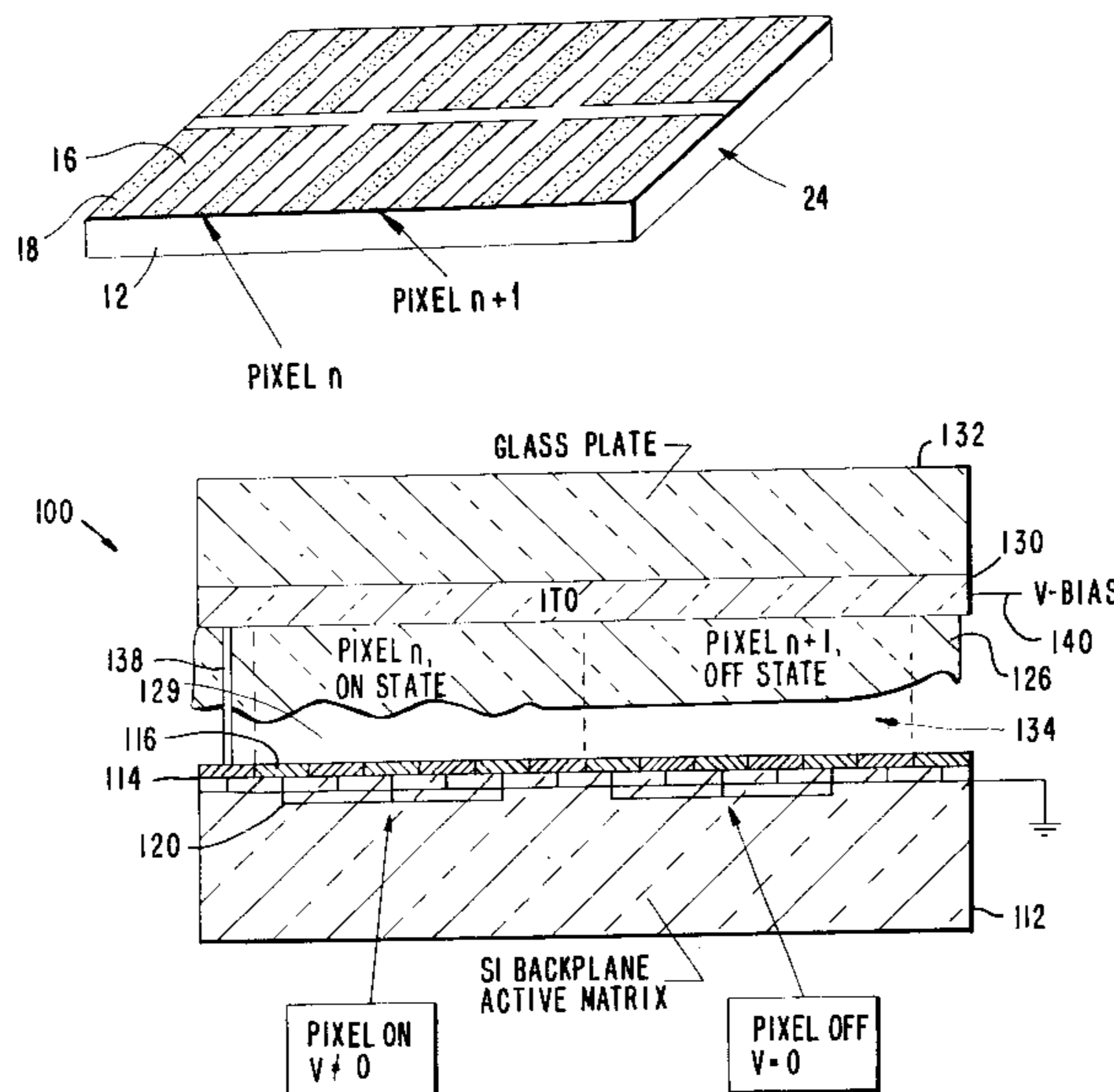

FIG. 1A

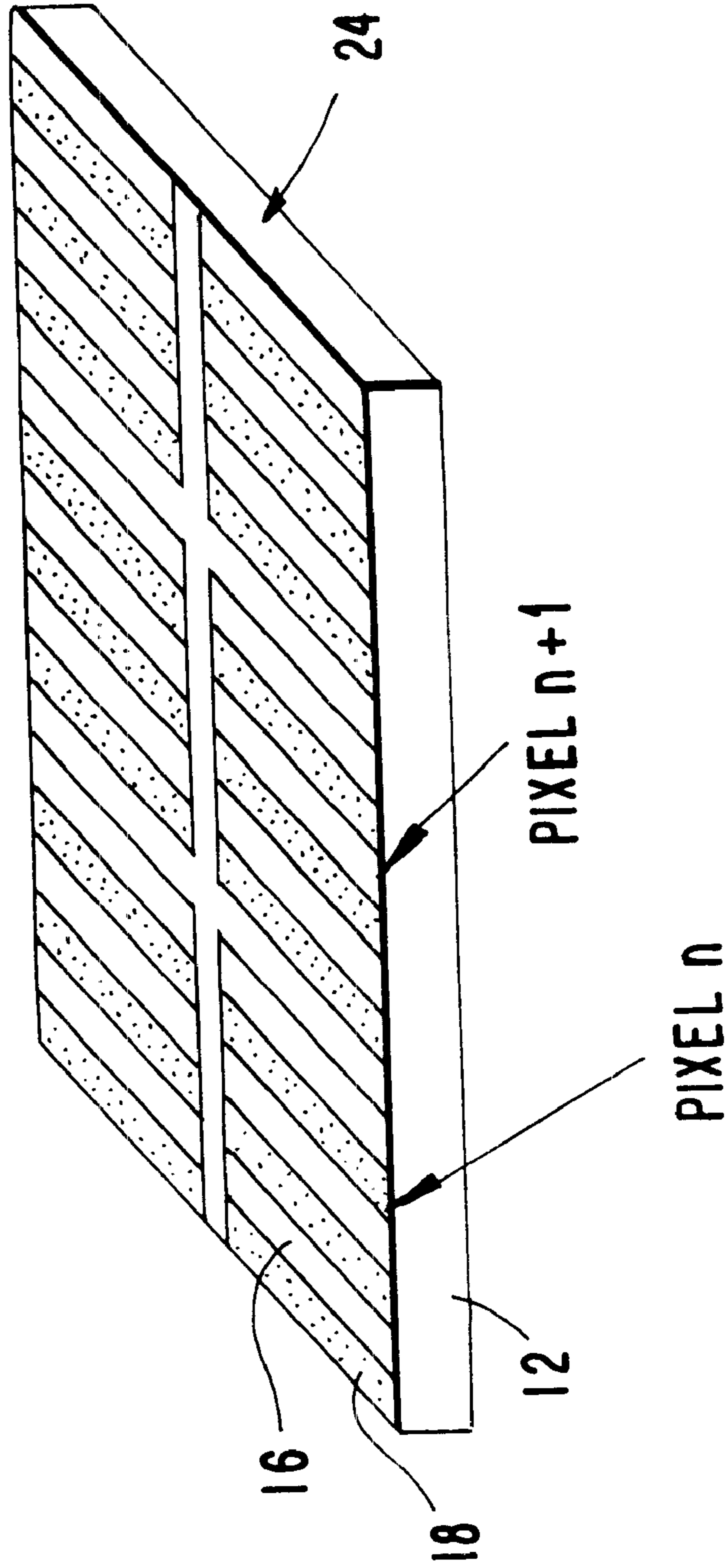
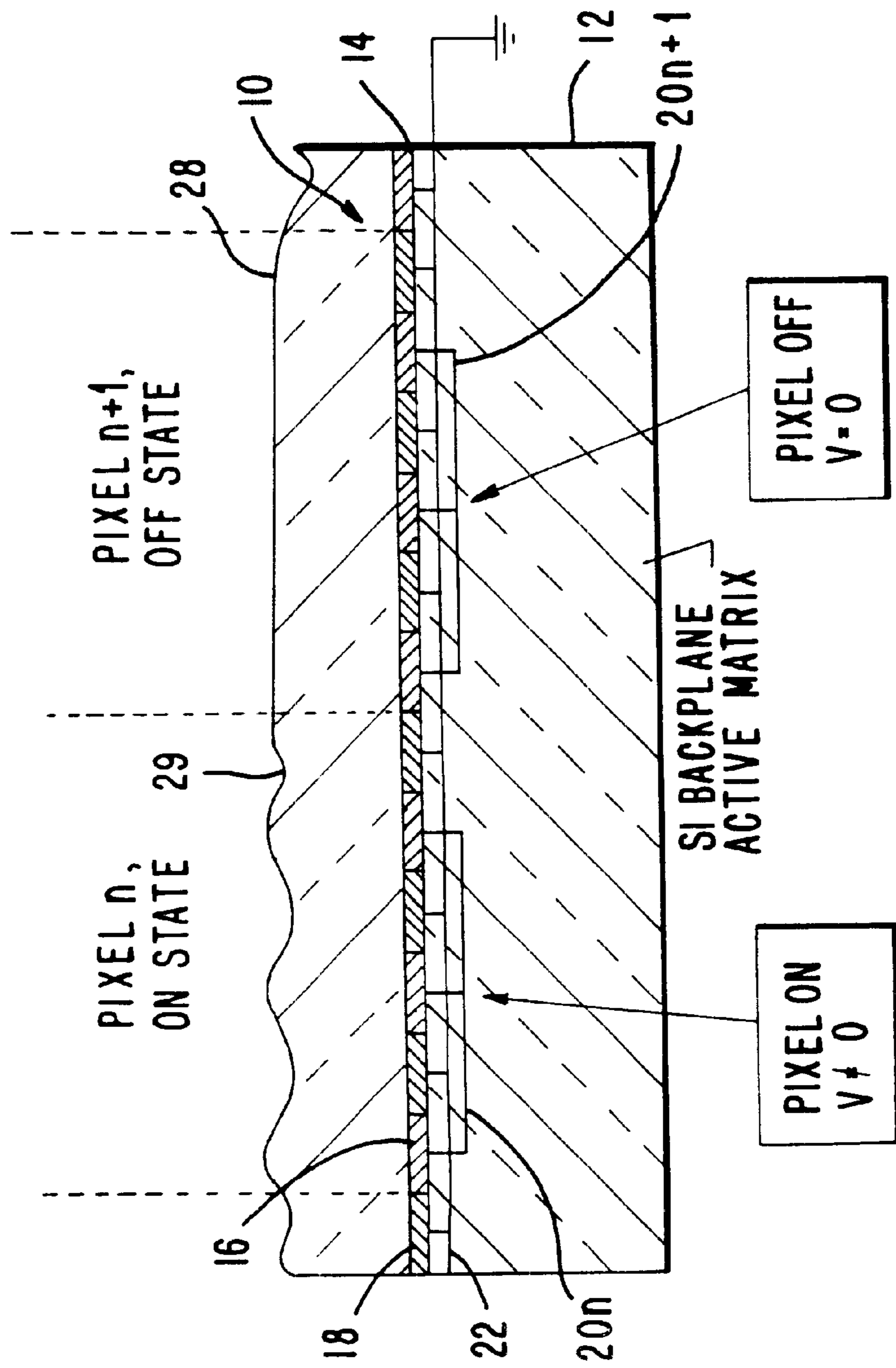

FIG. 1B



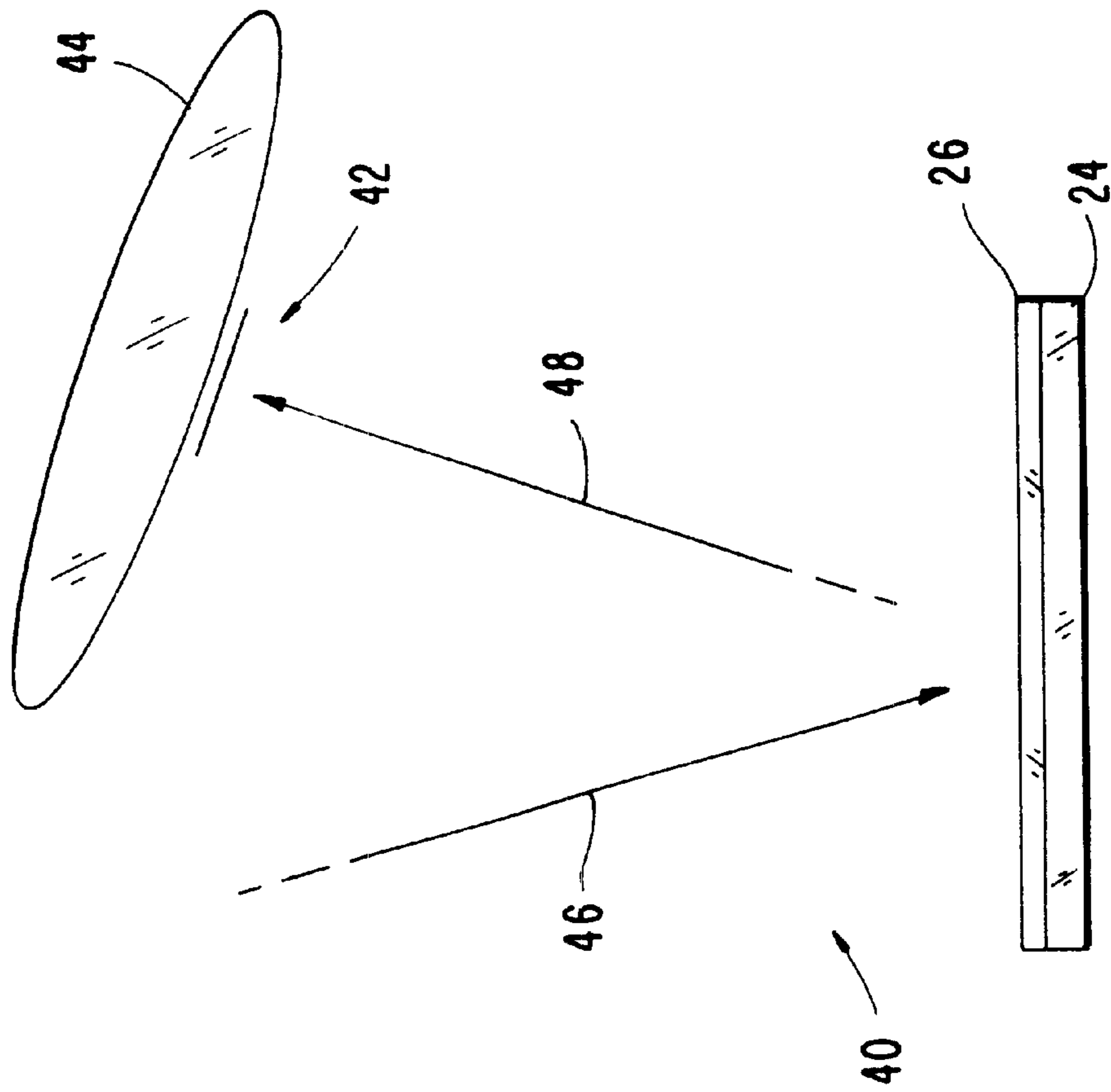

FIG. 2A

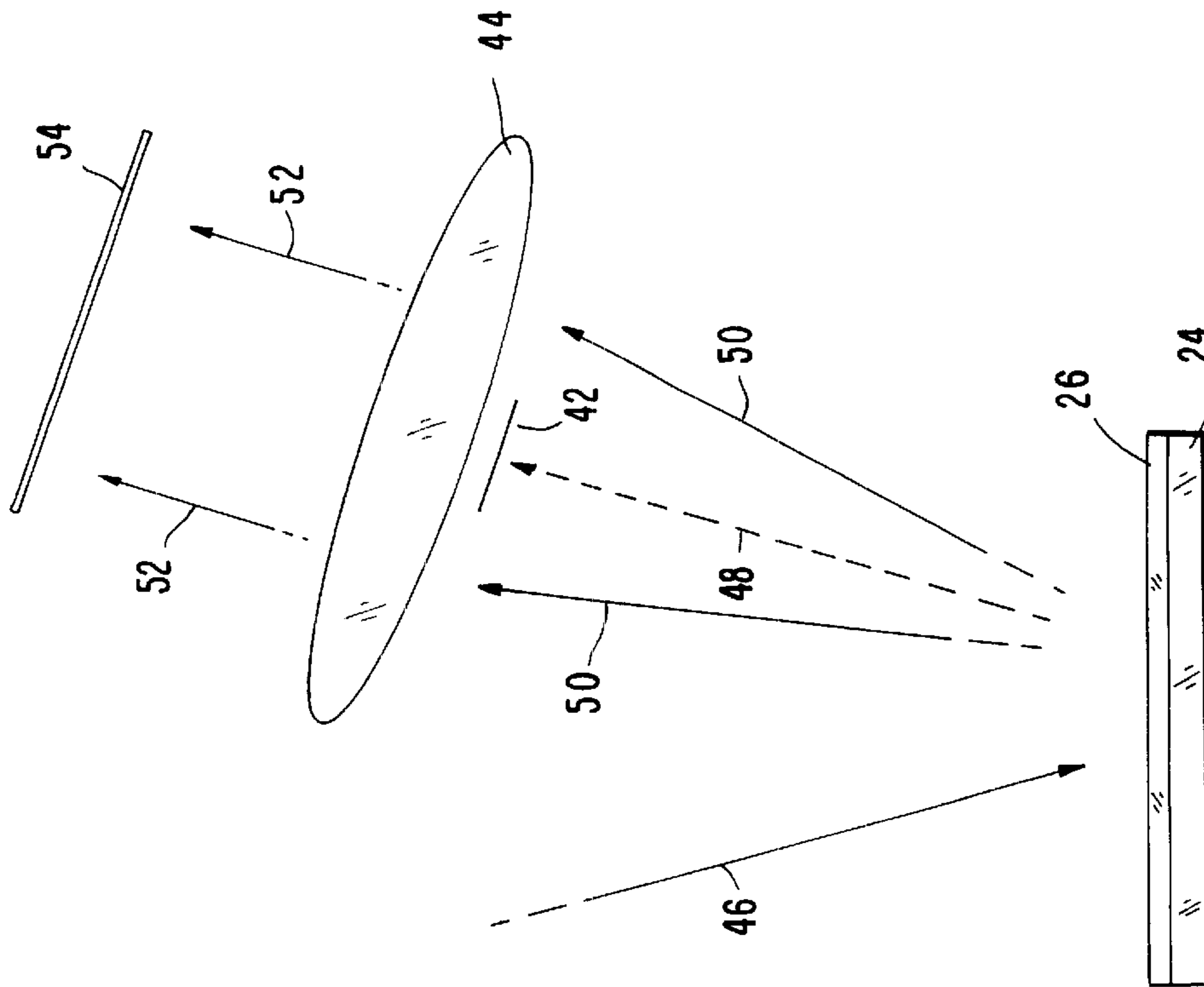

FIG. 2B



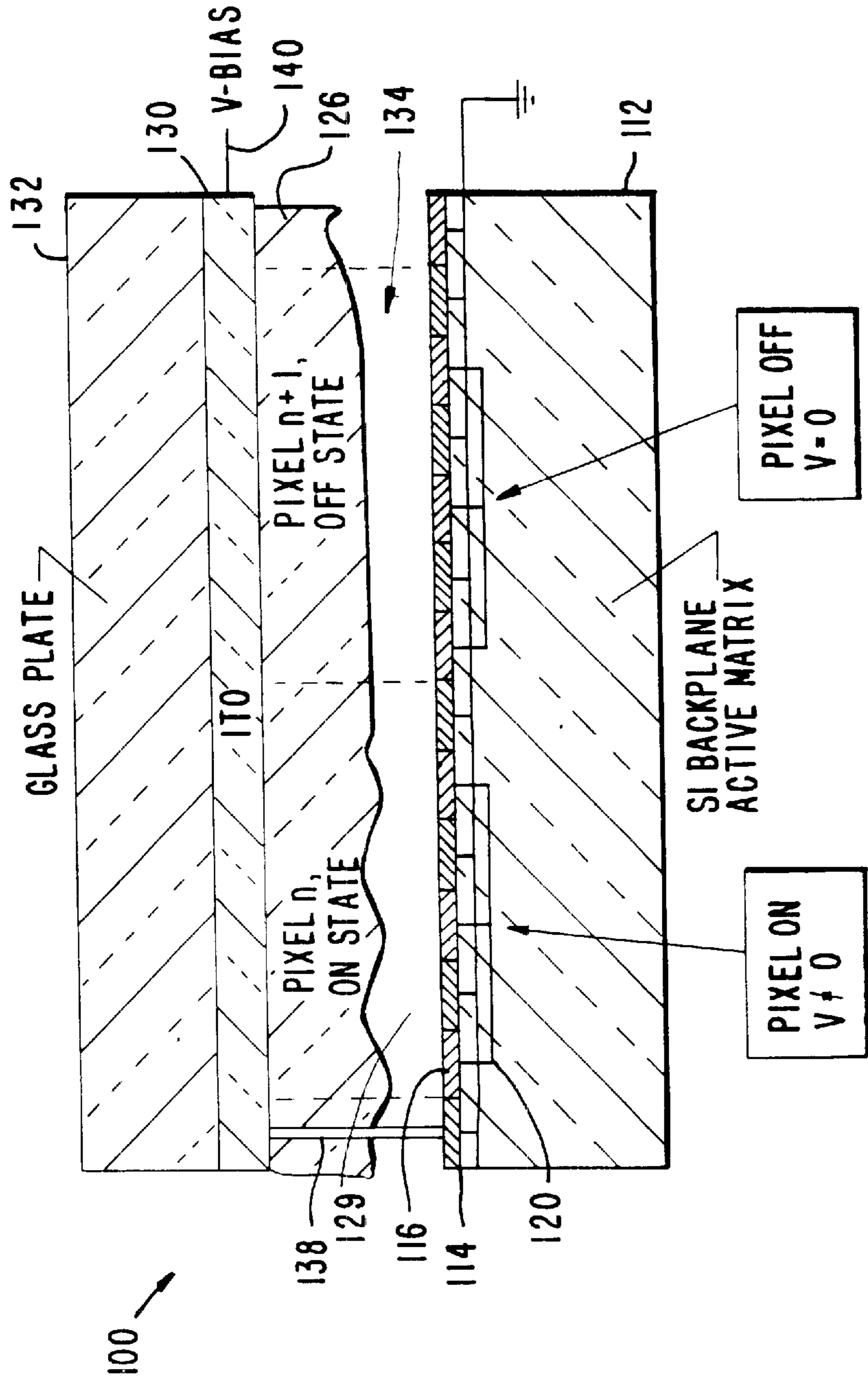

FIG. 3

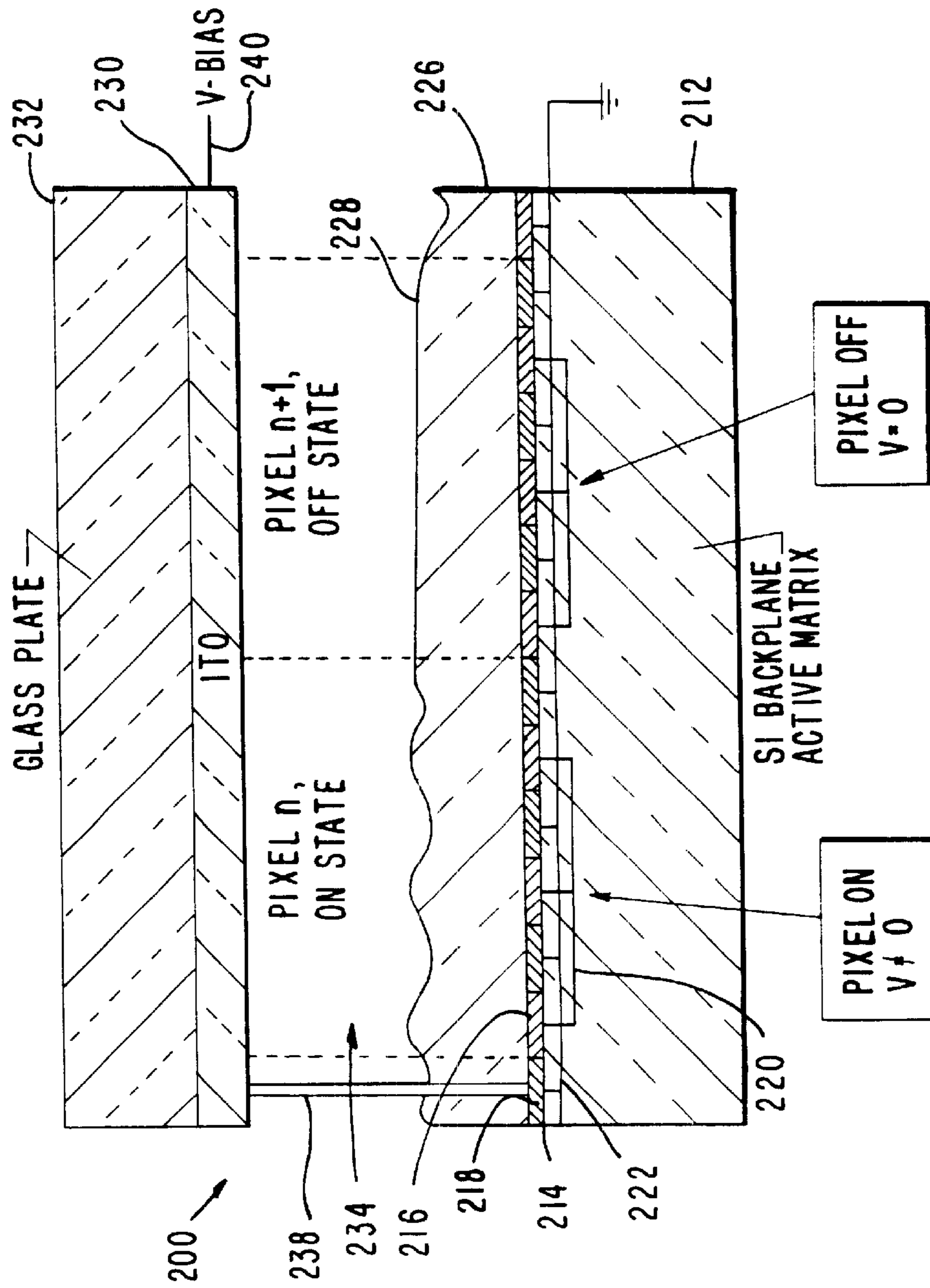

FIG. 4



**PIXEL STRUCTURE HAVING DEFORMABLE  
MATERIAL AND METHOD FOR FORMING  
A LIGHT VALVE**

**CROSS REFERENCE TO RELATED  
APPLICATIONS**

This application is a continuation-in-part of U.S. patent application Ser. No. 09/570,197 filed on May 12, 2000, which is a continuation-in-part of U.S. application Ser. No. 09/443,822 filed on Nov. 19, 1999.

**BACKGROUND OF THE INVENTION**

**1. Field of the Invention**

The present invention relates to electronic visual displays for displaying an image. More particularly, the present invention pertains to a light valve structure and fabrication method ID for use in a projection-type visual display.

**2. Description of the Related Art**

There are various types of visual electronic displays for displaying or imaging video information. For example, cathode ray tubes have long been employed in televisions and computer monitors wherein electron guns generate electrons which illuminate a target screen in response to an electronic signal. The electronic signal is typically derived from a transmitted video signal received by a receiver connected to the electron guns. The problem with such known systems is that they require relatively high voltages to operate the electron gun and to accelerate the emitted electrons.

Another type of display is a projection system which employs light valves to convert video signals into a viewable image which is then projected on a screen. One type of light valve technology is a grating light valvetrade (GLV) which is a micromechanical phase grating. By providing controlled diffraction of incident light, a GLV device will produce bright or dark pixels in a display system. With pulse width modulation, a GLV device will produce precise gray scale or color variations. Built using microelectromechanical systems (MEMS) technology, a GLV device can be made both small and inexpensively. A variety of display systems can be built using GLV technology, each benefiting from the high contrast ratio, fill ration and brightness. In addition, GLV technology can provide high resolution, low power consumption and digital gray-scale and color reproduction. A drawback of GLV technology is that it is complex to construct a matrix or two-dimensional array of pixels. If a one-dimensional array is constructed, mechanical scanning can be used to simulate a two-dimensional array.

Liquid crystal on silicon (LCOS) has also been used in projection display applications. This technology offers an inexpensive way of projecting an image on a screen. LCOS systems require polarized light for operation which results in a problem of color management in the polarization modulating panels. In LCOS panels, the polarization of incoming light results in a 50% decrease of the available light. Although polarization recovery systems can be used to improve the efficiency of light usage, such systems will only increase the efficiency to approximately 80%.

Still other types of light valves or light modulators comprise a deformable layer of material (commonly referred to as a gel layer), which is disposed over an array of electrodes. One such system is disclosed in U.S. Pat. No. 3,882,271 (Glenn). Such modulators include a metal reflective layer disposed on the surface of the gel which serves both as an electrode and as a light-reflecting medium.

**SUMMARY OF THE INVENTION**

The present invention is directed to a light valve or pixel structure for use in an electronic visual display. The structure

includes a semiconductor substrate having an upper surface with reflective conductors formed thereon. The conductors function as electrodes and are arranged into groups, with each group including an actuation electrode and a grounding electrode. A layer of transparent material is disposed on the electrodes. The transparent material is deformable in response to an electric field generated by the electrodes, which occurs when a voltage is applied to the electrodes. When light is incident on the transparent material, the light transmits through the material, reflects off of the electrodes, and again traverses the material layer. When the electrodes are activated, deformation in the material layer functions as a wavelength diffraction grating which diffracts the reflected light. The light can then be directed to a lens for focusing on a projection screen for displaying an image.

In another preferred embodiment, the layer of deformable material is formed on a transparent electrode supported by a transparent substrate. The deformable material is spatially disposed in opposing relation to a reflecting electrode formed on a semiconductor substrate. When a voltage is applied to the reflecting electrode, an electric field is formed between the reflecting electrode and the transparent electrode which causes deformations in the deformable material layer. As a result, incident light is diffracted by the deformations in the material.

In yet another preferred embodiment, a transparent electrode is formed on a second substrate positioned at a distance from the deformable transparent material. When a voltage drop is applied across the reflecting electrode and the transparent electrode, an electric field is formed between the reflecting electrode and the transparent electrode which causes deformations in the deformable material layer. As a result, incident light is diffracted by the deformations in the material.

The present invention is also directed to a method of forming a light valve device for diffracting and reflecting incident light. The method involves the positioning of a substrate formed of semiconductor material and forming a reflective electrode on a surface of the substrate. The reflective electrode is capable of receiving voltages for generating an electric field. A transparent substrate having a transparent electrode formed thereon is disposed at a distance above the reflective electrode. A layer of transparent dielectric material is then disposed on either of the transparent or reflective electrodes. The transparent dielectric material is capable of being deformed in response to the electric field so that when incident light is received by said substrate surface, the light will be diffracted by deformities in the layer and reflected by the electrode away from the surface.

Other objects and features of the present invention will become apparent from the following detailed description considered in conjunction with the accompanying drawings. It is to be understood, however, that the drawings are designed solely for purposes of illustration and not as a definition of the limits of the invention, for which reference should be made to the appended claims. It should be further understood that the drawings are not necessarily drawn to scale and that, unless otherwise indicated, they are merely intended to conceptually illustrate the structures and procedures described herein.

**BRIEF DESCRIPTION OF THE DRAWINGS**

In the drawings, wherein like reference numerals denote similar elements throughout the several views:

FIG. 1A depicts a schematic perspective view of an electrode array;

FIG. 1B is a cross-sectional view of a pair of pixels constructed in accordance with a presently preferred embodiment of the invention;



FIG. 2A depicts a representation of a light path for a pixel in an "off" state;

FIG. 2B depicts a representation of a light path for a pixel in an "on" state;

FIG. 3 is a cross-sectional view of a pair of pixels constructed in accordance with another embodiment of the present invention; and

FIG. 4 is a cross-sectional view of a pair of pixels constructed in accordance with yet another embodiment of the present invention.

#### DETAILED DESCRIPTION OF THE PRESENTLY PREFERRED EMBODIMENTS

In FIGS. 1A and 1B, a light valve or pixel structure **10** in accordance with a preferred embodiment of the present invention is shown. The structure **10** is formed on a semiconductor substrate **12**, such as silicon having an upper surface **14**. A plurality of contact terminals or electrodes **16**, **18**, are formed on the upper surface **14** of substrate **12** in any known manner, such as by using standard CMOS techniques, e.g. chemical vapor deposition, deposition lithography, etc. The electrodes are constructed of a light-reflecting, electrically conducting material, such as aluminum. Although FIG. 1B depicts a cross-section of only two full pixel structures, it will be appreciated that the structures are produced in bulk on a common semiconductor substrate to form an array **24** as shown in FIG. 1A (which shows six pixel structures) which can be incorporated in displays for various uses including, televisions, computer monitors, mobile phones, computer games, wristwatches, etc.

The electrodes **16**, **18** are disposed in parallel alternating relation to each other on substrate **12** and are designated as activation electrodes **16** and common or grounding electrodes **18**. Electrical connection between the electrodes is realized by contact lines or leads **20**, **22** so that the electrodes are connected in groups to form control terminals for the individual pixel elements. For example, a pixel *n* is shown in FIG. 1B having six electrodes, three of which are grounding electrodes which are connected to each other through leads **22**, and the remaining three electrodes of the pixel are activation electrodes **16** which are connected to each other through lead **20<sub>n</sub>**. As shown in FIG. 1B, the grounding electrodes from the pixel array **24** are connected to each other and, in operation, are connected to a common ground or zero voltage. A similar arrangement is illustrated for pixel *n+1* in FIG. 1B. Each pixel will be separately activated by applying voltages to the respective activation electrodes or leads (e.g. lead **20<sub>n+1</sub>** for pixel *n+1*). It will be understood that although the electrodes are shown in the drawings as having an even number such that they are grouped in pairs for each pixel, this need not be the case. Any electrode arrangement can be employed without departing from the scope of the present invention. Moreover, it will also be understood that the number of electrodes shown for each pixel element (i.e. 6 electrodes) in FIG. 1B is arbitrary and the number can be increased or decreased depending on the particular pixel application or use.

With continued reference to FIG. 1B, the pixel structure **10** includes a layer of electrically deformable transparent material **26** having a surface **28** and disposed over the reflective electrodes **16**, **18** on the substrate **12**. Suitable transparent material **26** includes, for example, silicone gel, oil, various polymer materials or other viscous substances that have a tendency to deform when placed in the presence of an electric field. When the activation electrodes **16** of a particular pixel (*n*) are energized by applying a voltage thereto, an electric field between adjacent activation electrodes will form and cause surface **28** on the deformable transparent material **26** to contract or deform. At this point,

the pixel is in an "on" state. When voltage is no longer applied, the surface **28** returns to a quiescent or "off" state (shown in pixel *n+1*). The surface deformities or ripples in material **26** function as a wavelength diffraction grating for diffracting incident light received by or directed at the valve **10**.

As is known in general projection screen technology, the activation electrodes of each pixel in an array will receive an element of video information derived from a video signal. The element of video information is typically in the form of a stored charge which is applied to the pixel structures, e.g. the electrodes in the array **24**. The application of the charge to the activation electrodes causes the deformable material layer **26** to deform in response to the level of charge applied.

FIGS. 2A and 2B illustrate the use of a single pixel structure in a projection system such as a Schlieren optical system which includes a beam stop **42** and an imaging lens **44**. The imaging lens focuses light that avoids the beam stop **42** on a destination (e.g. a projection screen). In FIG. 2A, the pixel is depicted in its "off" or "black" state. Incident light **46** passes through the deformable material layer **26** in a first direction, reflects off of the reflective electrodes **16**, **18** formed on substrate **24**, and is directed back as reflected light **48** through layer **26** for receipt by the lens stop **42**. Due to appropriate placement or location of lens stop **42**, substantially all of the reflected light **48** is absorbed and does not reach lens **44** for imaging.

FIG. 2B illustrates the pixel structure in an "on" or "white" state. In this state, a voltage is applied to electrodes **16**, **18** for causing deformation in transparent material layer **26**. When in the "white" state, as incident light **46** is received and reflected by electrodes **16**, **18**, the deformations or ripples cause the outgoing or reflected light to diffract or spatially shift (as shown by arrows **50**). Due to the shift, the diffracted light is no longer directed at lens stop **42** but passes to lens **44** for focusing (shown as arrows **52**) on a projection screen **54**. The use of the gel material layer **26** in the pixel structure **10** of the present invention allows non-polarized light to be used to illuminate the electrodes **16**, **18**. Thus, the problem of inefficient light use present in prior liquid crystal projection display systems is avoided.

With reference now to FIG. 3, an alternative pixel structure **100** in accordance with the present invention is shown. This embodiment is similar to structure **10** in that it includes an array of active and grounding reflective electrodes **116**, **118** formed on a semiconductor substrate **112**. However, instead of material layer **126** formed directly on the substrate surface over the electrodes, the material layer is formed on a transparent electrode **130** which is disposed on and supported by a transparent substrate **132**. The transparent electrode **130** is preferably made of indium tin oxide, as is known in the art, and the transparent substrate is a glass material.

As shown in FIG. 3, substrate **132** with material layer **126** disposed thereon is suspended above reflective electrodes **116**, **118** by spacer elements **138** so that a deformation gap to **134** is formed. Gap **134** can be air, gas or a vacuum, and provides a region for allowing deformation of material **126** without the material contacting the reflective electrodes. In operation, the transparent electrode **130** is maintained at the bias voltage potential *V*-bias **140**. When an activation voltage is applied to the activation electrodes **116**, such as to activate pixel *n*, an electric field is generated between the transparent electrode and the reflective electrodes which causes the formation of ripples in the material layer **126**. This electric field passes through the entire material layer **126** and allows the material layer to be manipulated at reduced voltage values relative to the voltages required for operation of the pixel structure **10** in FIG. 1B. In other words, increased diffraction angles can be realized at lower voltages than those resulting from the structure **10** of FIG. 1B.



5

With reference now to FIG. 4, an alternative pixel structure **200** in accordance with yet another embodiment of the present invention is shown. This embodiment is similar to structure **100** of FIG. 3 in that it includes an array of active and grounding reflective electrodes **216**, **218** formed on a semiconductor substrate **212**. In this embodiment, a deformable material layer **226** formed directly on the substrate surface over the electrodes. A transparent substrate **232** is provided for supporting a transparent electrode **230** thereon. Like the transparent electrode **130**, transparent electrode **230** is preferably made of indium tin oxide (ITO) and is biased by bias voltage V-bias **240**. The transparent substrate is a glass material.

As shown in FIG. 4, substrate **232** with a transparent electrode **230** disposed thereon is suspended above the material layer **226**, which is disposed on reflective electrodes **216**, **218** by spacer elements **238** so that a deformation gap **234** is formed. Like the embodiment of FIG. 3, gap **234** can be air, gas or a vacuum, and provides a region for allowing deformation of material **226** without the material contacting the transparent electrode **230**. In operation, the transparent electrode **230** is maintained at the same voltage potential as the grounding electrodes **218**, i.e. connected to ground. When an activation voltage is applied to the activation electrodes **216**, such as to activate pixel n, an electric field is generated between the transparent electrode and the reflective electrodes which causes the formation of ripples in the material layer **226**. This causes the material layer to be manipulated at reduced voltage values.

Thus, while there have shown and described and pointed out fundamental novel features of the invention as applied to a preferred embodiment thereof, it will be understood that various omissions and substitutions and changes in the form and details of the devices illustrated, and in their operation, may be made by those skilled in the art without departing from the spirit of the invention. For example, it is expressly intended that all combinations of those elements which perform substantially the same function in substantially the same way to achieve the same results are within the scope of the invention. Moreover, it should be recognized that structures and/or elements shown and/or described in connection with any disclosed form or embodiment of the invention may be incorporated in any other disclosed or described or suggested form or embodiment as a general matter of design choice. It is the intention, therefore, to be limited only as indicated by the scope of the claims appended hereto.

What is claimed is:

1. A light valve device for diffracting and reflecting incident light, comprising:
  - a substrate formed of semiconductor material;
  - a reflective electrode formed on a surface of said substrate and capable of receiving voltages;
  - a transparent substrate;
  - a transparent electrode formed on said transparent substrate; and
  - a layer of transparent dielectric material disposed on one of said transparent electrode and said reflective electrode and distally positioned in opposing spaced relation from the other of said reflective electrode and transparent electrode so that a gap is formed between said reflective electrode and said transparent electrode, said transparent and reflective electrodes forming an electric field through said transparent material when a potential difference is applied between said reflective

6

electrode and said transparent electrode, said transparent material being capable of being deformed in response to the electric field so that when incident light is received by said valve, the light will be diffracted by deformities in said layer and reflected by said reflecting electrode.

2. The valve of claims **1**, wherein said semiconductor substrate comprises silicon and said transparent substrate comprises glass.

3. The valve of claim **1**, wherein said transparent electrode comprises indium-tin-oxide.

4. The valve of claim **1**, further comprising spacers for maintaining spaced relation between said transparent material and said reflecting electrode.

5. The valve of claim **1**, wherein said layer of transparent dielectric material is disposed on said transparent electrode.

6. The valve of claim **1**, wherein said layer of transparent dielectric material is disposed on said reflective electrode.

7. The valve of claim **1**, wherein said reflecting electrode comprises a plurality of actuating electrodes and a plurality of grounding electrodes arranged to form an array of valves, and wherein said grounding electrodes are maintained at a common voltage with each other.

8. A method of forming a light valve device for diffracting and reflecting incident light, comprising the steps of:

positioning a substrate formed of semiconductor material; forming a reflective electrode on a surface of said substrate, said reflective electrode being capable of receiving voltages;

positioning a transparent substrate;

forming a transparent electrode on said transparent substrate;

disposing a layer of transparent dielectric material on one of said transparent electrode and said reflective electrode; and

distally positioning said transparent electrode in opposing spaced relation from said reflective electrode so that a gap is formed between said transparent electrode and said reflective electrode for forming an electric field through said transparent material between said transparent and reflective electrodes when a potential difference is applied between said reflective electrode and said transparent electrode, said transparent material being capable of being deformed in response to the electric field so that when incident light is received by said valve, the light will be diffracted by deformities in said layer and reflected by said reflecting electrode.

9. The method of claim **8**, wherein said step of disposing comprises disposing the dielectric material on said transparent electrode.

10. The method of claim **8**, wherein said step of disposing comprises disposing the dielectric material on said reflective electrode.

11. The method of claim **8**, wherein said semiconductor substrate comprises silicon and said transparent substrate comprises glass.

12. The method of claim **8**, wherein said transparent electrode comprises indium-tin-oxide.

13. The method of claim **8**, wherein said reflecting electrode comprises a plurality of actuating electrodes and a plurality of grounding electrodes arranged to form an array of valves, and wherein said grounding electrodes are maintained at a common voltage with each other.

\* \* \* \* \*