



US006431285B2

(12) **United States Patent**
Hopper et al.

(10) **Patent No.:** **US 6,431,285 B2**
(45) **Date of Patent:** ***Aug. 13, 2002**

(54) **APPARATUS FOR DRILLING AN OFFSHORE UNDERWATER WELL**

FOREIGN PATENT DOCUMENTS

(75) Inventors: **Hans Paul Hopper**, Whiterashes;
David Garnham, NR Leeds, both of
(GB)

GB 2148842 6/1995
GB 2307929 6/1997

(73) Assignee: **Cooper Cameron Corporation**,
Houston, TX (US)

OTHER PUBLICATIONS

(*) Notice: This patent issued on a continued prosecution application filed under 37 CFR 1.53(d), and is subject to the twenty year patent term provisions of 35 U.S.C. 154(a)(2).

1998-99 Cameron Catalog; selected pages; Mar. 1998; (17 p.).

Through-Flowline (TFL) Equipment; Otis; (undated)(p. 240).

Subject to any disclaimer, the term of this patent is extended or adjusted under 35 U.S.C. 154(b) by 0 days.

Winton, Jack; *Use of Multi-Lateral Wells to Access Marginal Reservoirs*; Offshore; Feb. 1999; (3 p.)

Jee, T., et al; *The Use of Screwed Flowlines in Deepwater*; DOT Conference 1993; Nov. 18, 1993; (16 p.).

(21) Appl. No.: **09/275,346**

* cited by examiner

(22) Filed: **Mar. 24, 1999**

(30) **Foreign Application Priority Data**

Mar. 27, 1998 (GB) 98302386

(51) **Int. Cl.**⁷ **E21B 17/01**; E21B 43/01

(52) **U.S. Cl.** **166/368**; 175/7

(58) **Field of Search** 166/335, 367,
166/368, 92.1; 175/5, 7, 10

Primary Examiner—David Bagnell
Assistant Examiner—John Kreck

(74) *Attorney, Agent, or Firm*—Conley, Rose & Tayon, P.C.

(57) **ABSTRACT**

(56) **References Cited**

U.S. PATENT DOCUMENTS

- 3,885,623 A * 5/1975 Watkins et al. 166/368
- 4,030,310 A 6/1977 Schirtzinger 61/86
- 4,326,595 A 4/1982 Burns 175/9
- 4,462,717 A 7/1984 Falcimaigne 405/195
- 4,695,189 A 9/1987 Wallace 405/169
- RE32,623 E 3/1988 Marshall et al. 175/9
- 4,754,817 A 7/1988 Goldsmith 175/7
- 5,697,447 A * 12/1997 Borseth 166/366
- 5,702,205 A 12/1997 Mahone et al. 405/169

A method of drilling an offshore underwater well comprising the steps of installing a riser conduit so that it is substantially vertically supported at a production deck. The riser conduit deviates progressively further from the vertical with increasing sea depth, so that its end can be anchored at the seabed by a skid either at an oblique angle so that drilling into the seabed can be carried out at the oblique angle, or horizontally, so that the riser conduit can extend some considerable distance across the seabed before drilling is carried out.

20 Claims, 7 Drawing Sheets

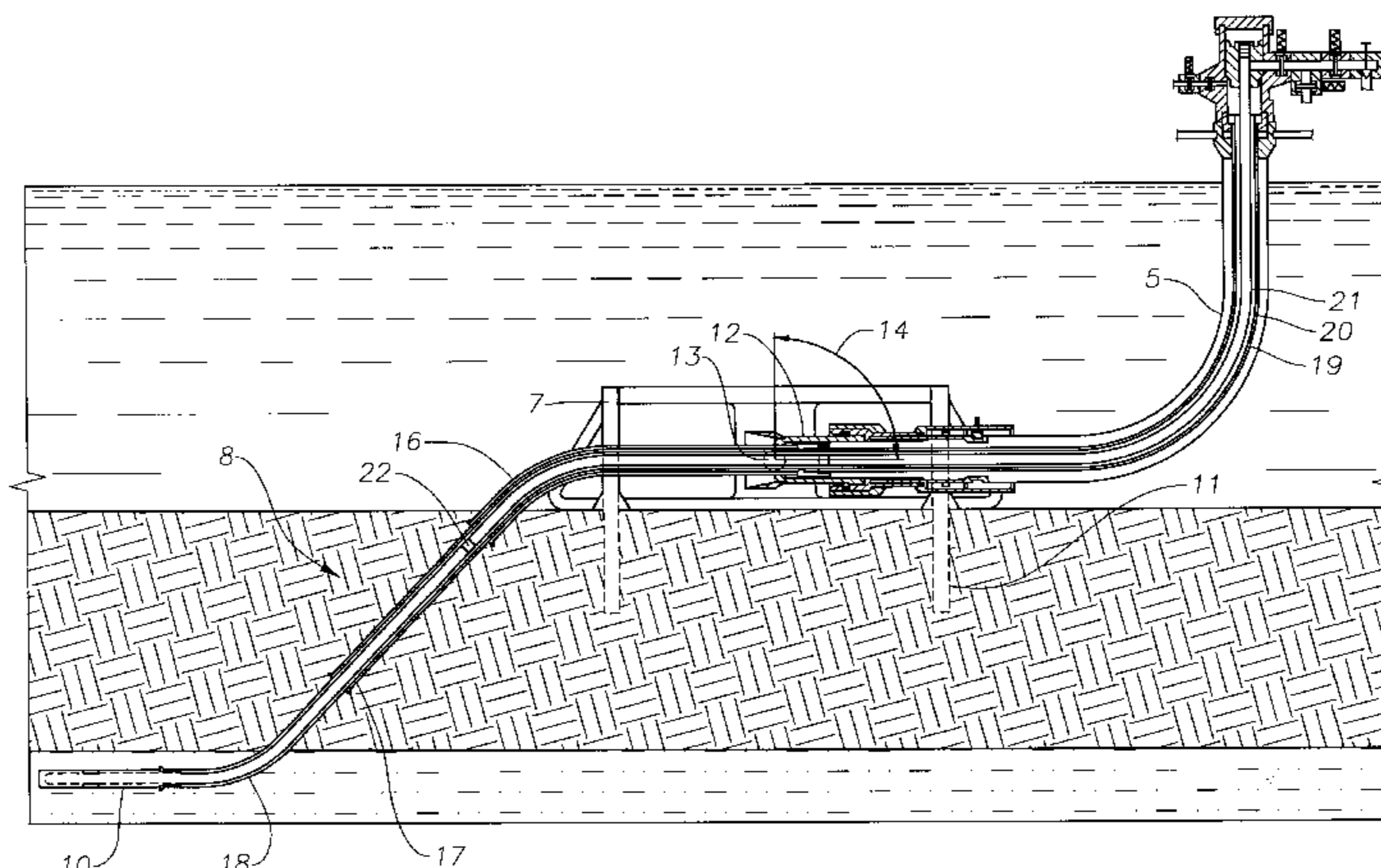

Fig. 1

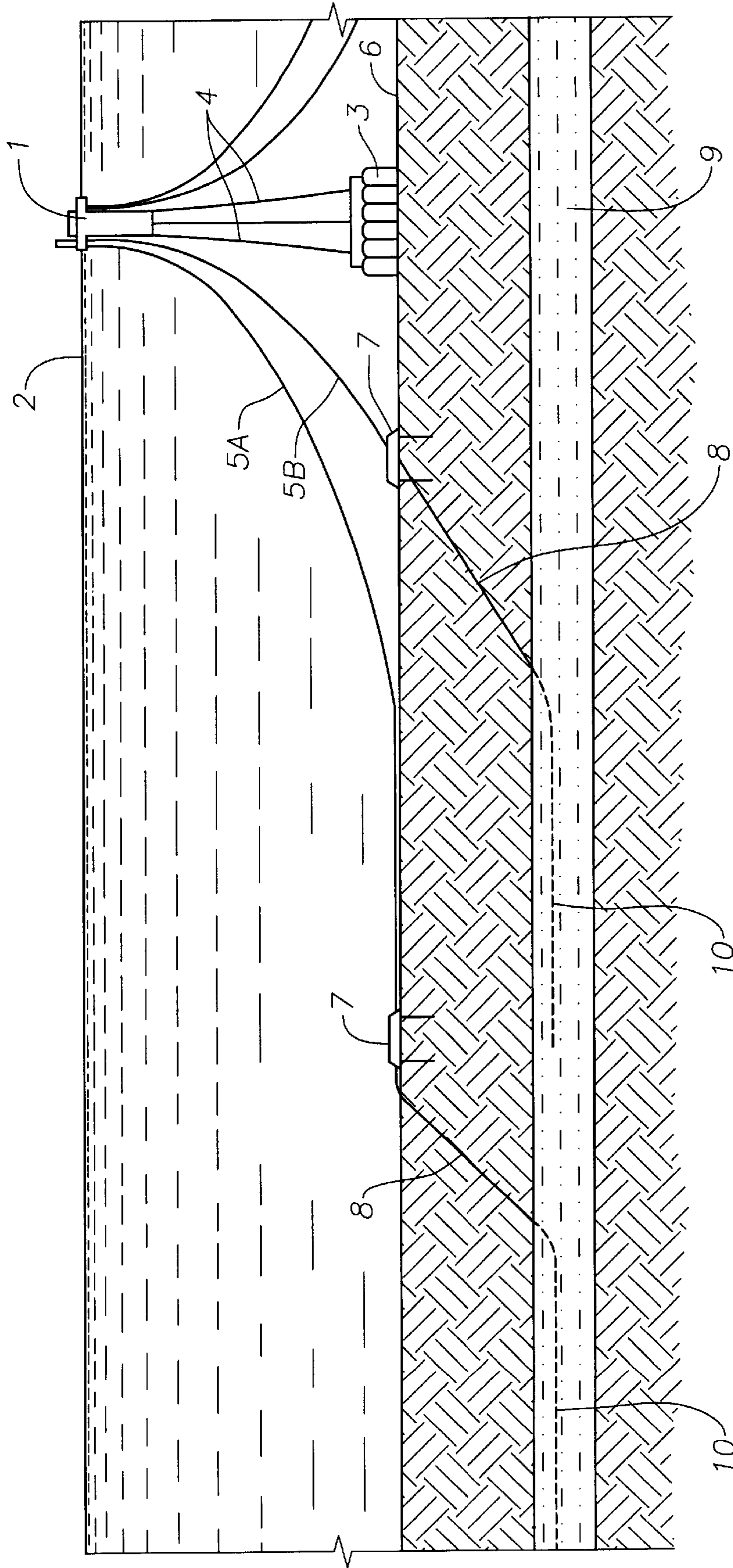

Fig. 3A

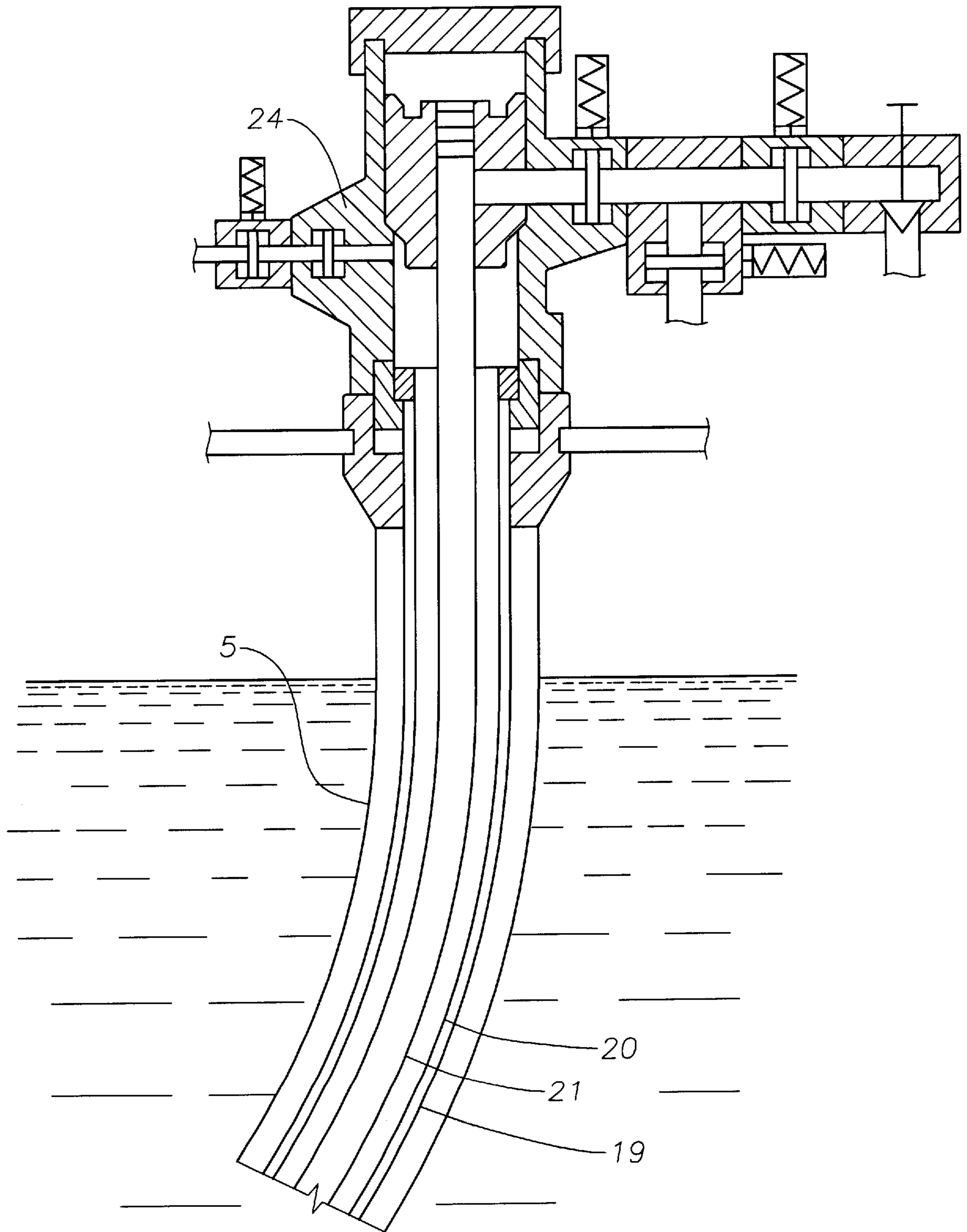
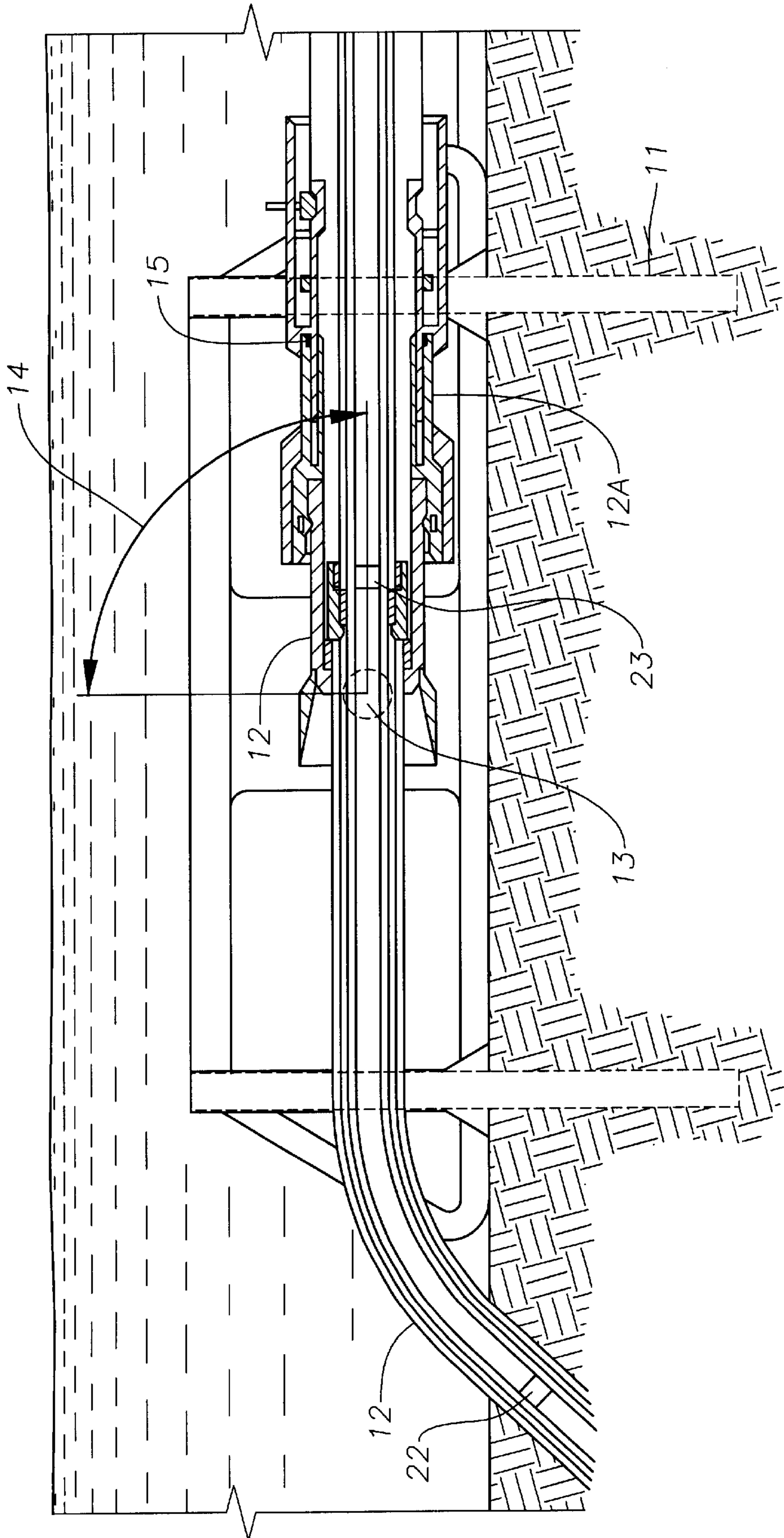

Fig. 3B



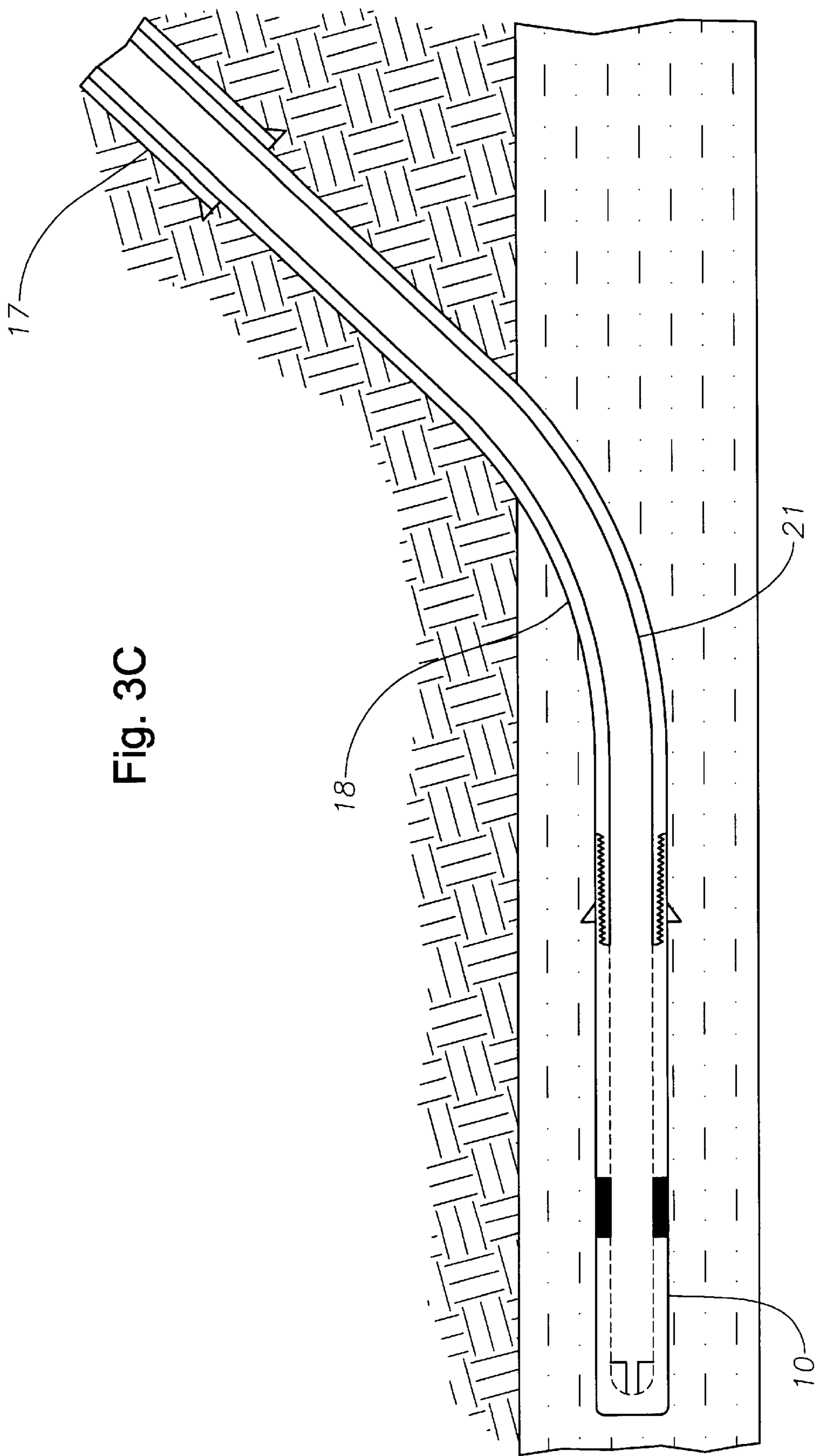

Fig. 3C

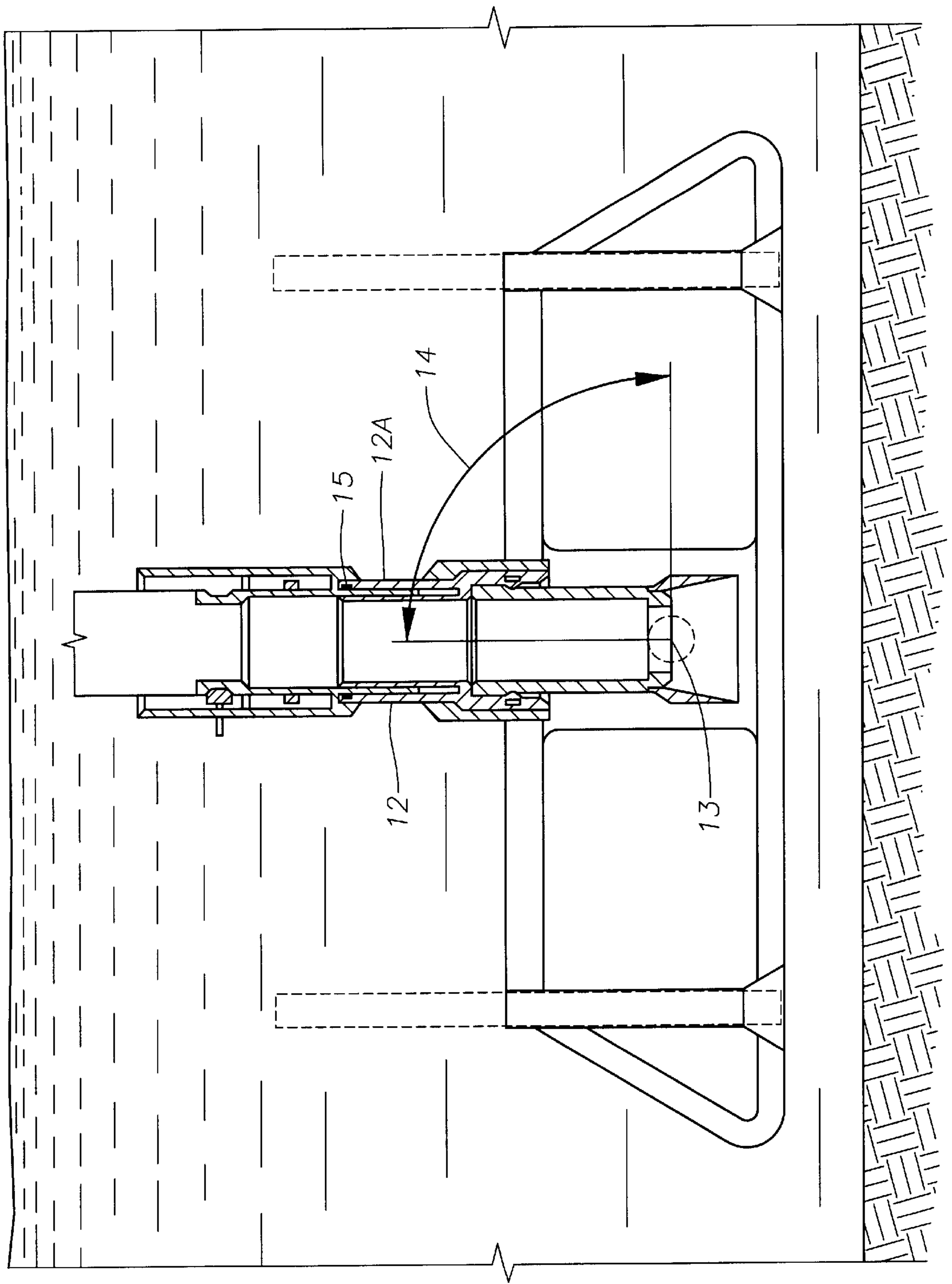
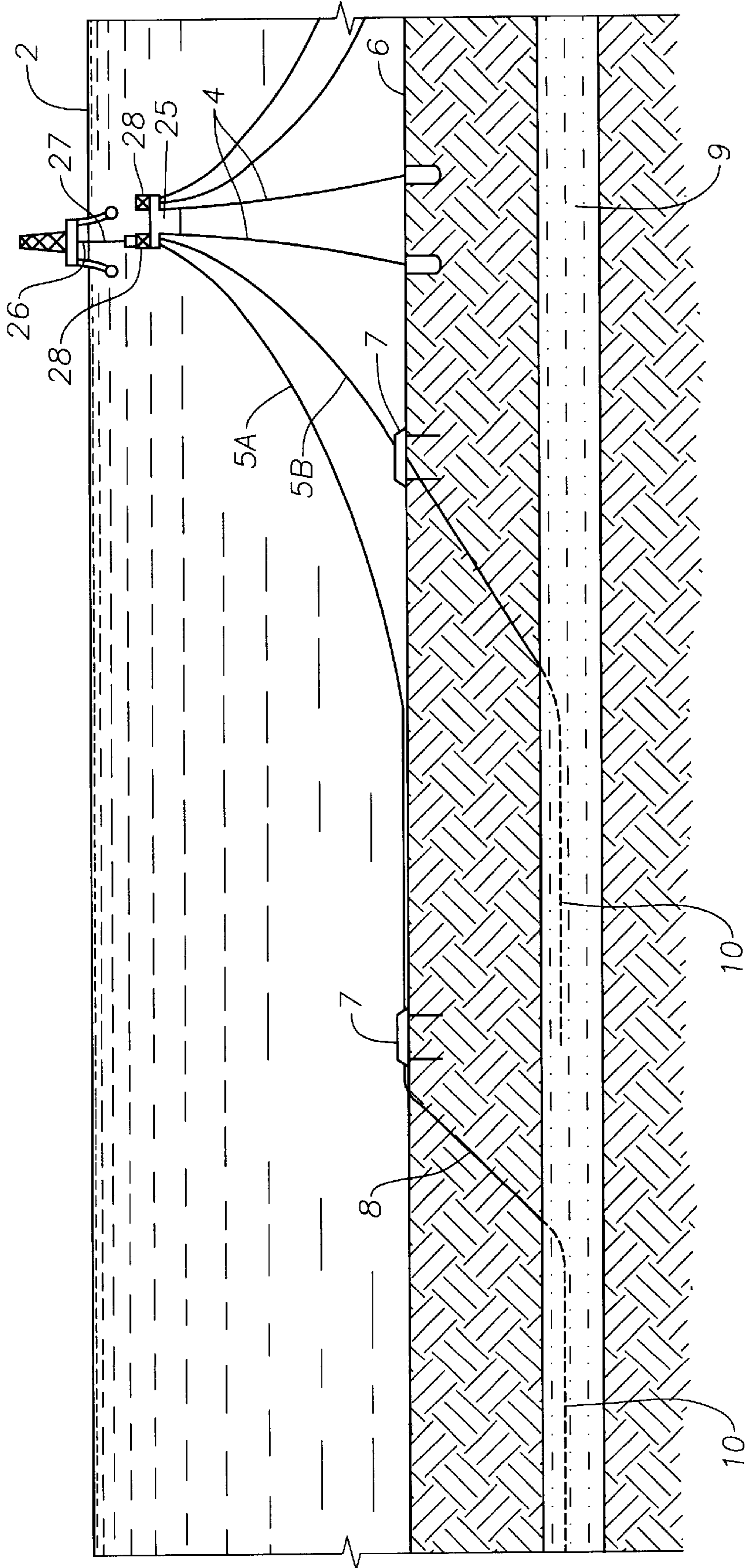

Fig. 3D

Fig. 4



APPARATUS FOR DRILLING AN OFFSHORE UNDERWATER WELL

CROSS-REFERENCE TO RELATED APPLICATION

The present application claims the benefit of 35 U.S.C. 119(a) of EP Serial No. 98302386.2 filed Mar. 27, 1998, and entitled METHOD AND APPARATUS FOR DRILLING AN OFFSHORE UNDERWATER WELL.

BACKGROUND OF THE INVENTION

The present invention relates to a method and apparatus for drilling an offshore underwater well.

Two conventional methods exist for drilling an offshore underwater well. The first of these is to drill and set a conductor pipe between a surface platform and the sea bed followed by drilling a surface well using a platform wellhead. The BOP is located on the surface wellhead. Subsequent casing strings are landed in the surface wellhead. The well is completed by suspending completion tubing from the wellhead and installing a platform tree. A second method is to drill and set a conductor pipe into the seabed using a floating drilling vessel with the wellhead located on the bed. A subsea drilling BOP has to run on a drilling riser down to the seabed and is connected to the subsea wellhead. A subsea well is drilled with subsequent casing hangers landed in the subsea wellhead. The well is completed by placing a conventional tree on the seabed wellhead. An alternative subsea option is to use a horizontal tree and then run the tubing.

As the industry moves further offshore and beyond the continental shelf, the water depths being considered are drastically increasing as reservoirs down the flank of the continental shelf and on the ocean floors are discovered. These water depths rule out the use of conventional platforms and their low cost drilling techniques. Floating or tension production platform systems can be used but their drilling footprint into the reservoir is limited, requiring peripheral seabed subsea production support wells. Subsea fields involve considerable complex subsea architecture and require extensive high cost rig intervention.

One way in which an attempt has been made to increase the footprint of a production platform is the provision of a slanted conductor. In such an arrangement, the conductor is supported at an angle by the platform so that it can be run in at an angle thereby increasing the lateral distance between the base of the platform and the location where the conductor meets the seabed. However, such an arrangement is awkward and costly as it requires a specially made structure to support the conductor at an angle. Further, the system will not work in deep water without some support for the conductor at various locations between the surface and the seabed which is not available from a floating platform.

SUMMARY OF THE INVENTION

According to the present invention, a method of drilling an offshore underwater well comprises the steps of installing a riser conduit so that it is substantially vertically supported at a production deck situated substantially at the sea surface and deviates progressively further from the vertical with increasing sea depth, fixing the riser conduit at the seabed in

a non-vertical orientation, and drilling the well into the seabed at an angle to the vertical.

As the riser conduit is substantially vertically supported at the production deck, it is possible to use conventional platform drilling and production techniques which help keep the costs to a minimum. Further, because the riser conduit is supported at the surface and at the seabed, and deviates progressively further from the vertical in between, intermediate support is not required but can be provided if necessary by buoyancy modules.

In some fields, the reservoir could be relatively close to the seabed. In such a case, there is insufficient depth for a conventional subsea well which starts vertically at the seabed to be deviated to a sufficient angle to access reservoir formations not already being drained by nearby vertical or deviated wells. Therefore only a limited reservoir acreage can be accessed. With the present invention, some of this deviation from the vertical is already provided before reaching the seabed, so that less deviation is required underground which allows higher angle or horizontal wells to be drilled far along the reservoir. This allows better access to reservoirs which are close to the seabed. However, the most important benefit of the present invention arises when the water is sufficiently deep that the riser conduit can be deviated to be horizontal at the seabed. Once the riser conduit becomes horizontal, it is possible to extend it some considerable distance along the seabed before drilling into the seabed so that the drilling footprint of a platform can be greatly increased without drilling.

There are a number of different ways in which the riser conduit can be installed. According to a first method, the riser conduit is run from an installation vessel with a skid attached, installed vertically and pivotally connected at the seabed, the installation vessel is moved horizontally to the production installation while the riser conduit is fed out from the installation vessel, and the riser conduit is transferred to the production installation. According to a second method, the production deck is offset from the location where the riser conduit is connected to a skid and is to be fixed at the seabed, the riser conduit is connected to a skid and is fed down from the production deck and is manoeuvred out to the end target location at the seabed. According to a third method the riser conduit is pre-made and towed to the appropriate location before being fixed at the production deck and fixed at the seabed. In this third case, the pipe may be towed out just off the seabed, and one end raised to the production deck. Alternatively, the pipe may be towed out and hung off at the platform before being lowered to the seabed and fixed.

According to a second aspect of the present invention, an offshore wellhead assembly comprises a production deck at which a riser conduit is vertically suspended, the riser conduit deviating progressively further from the vertical with increasing sea depth, the riser conduit being fixed at an angle to the vertical at the seabed by a fixture, and a cased well extending into the seabed from the fixture. This arrangement provides the same advantages of being able to access reservoirs areas close to the seabed, and increase the drilling footprint of the production installation as referred to above.

The riser conduit may be rigidly locked to the fixture. However, in order to provide ease of installation and a

fixture which can accommodate the riser at any angle it is preferable for the riser conduit to be pivotally attached to the fixture.

The fixture is preferably in the form of a skid having a gravity base or piles to secure it to the seabed. The skid is readily able to be transported to the correct location and can be simply secured to the seabed by the base or the piles.

BRIEF DESCRIPTION OF THE DRAWINGS

Examples of methods and assemblies in accordance with the present invention will now be described with reference to the accompanying drawings, in which:

FIG. 1 is a schematic view of an assembly according to a first example;

FIG. 2 shows the assembly of FIG. 1 in greater detail;

FIGS. 3A–3D show details of elements of FIG. 2; and

FIG. 4 is a schematic view of a second example.

DESCRIPTION OF THE PREFERRED EMBODIMENTS

FIG. 1 shows an example of a tension leg production installation 1 which is shown at the sea surface and is anchored to an optional gravity storage base 3 by mooring legs 4. From the production installation a number of riser conduits 5A, 5B are suspended initially vertically, but deviating progressively from the vertical with increasing sea depth. The conduit 5A has sufficient curvature that by the time it reaches the seabed 6 it is horizontal and can extend a significant horizontal distance along the seabed. At the desired location, the conduit 5A terminates at a skid 7 from which a cased well 8 extends towards the production reservoir 9 where a liner or screen 10 can be positioned. The conduit 5B is of similar construction, with the one exception that it is not horizontal at the seabed. Instead, it is fastened at an oblique angle to the skid 7 and the cased well 8 extends at the same angle into the seabed.

The details of the horizontally extending arrangement of conduit 5A are shown in more detail in FIG. 2 and FIGS. 3A–3D and installation of the wellhead assembly will be described with reference to these drawings.

The first stage of the installation is to install the riser conduit, which is in this particular example a well riser conduit, from the production installation 1 to the skid 7, and connected to the skid secured to the seabed. This can be done in a number of ways. Firstly, the skid 7 can be fixed to the end section of the riser conduit at the production platform. The riser conduit is then run vertically from the production platform and is manoeuvred out towards the seabed target zone. When correctly positioned the skid 7 is fixed to the seabed. As a second method, instead of running the riser conduit vertically from the production installation, the riser conduit can be pre-made and can be horizontally towed to the desired location, where it is attached at one end to the production deck 1. The riser conduit is then positioned on the seabed and the skid 7 is fixed to the seabed. A third alternative which can be used with a installation vessel instead of a tension leg production installation deck is to position the installation vessel immediately above the skid 7 and run the drilling riser conduit vertically to attach it to the skid 7 as shown in FIG. 3D which is pre-installed on the

seabed as previously described. The installation vessel can then be moved across to the production platform. The end of the riser conduit is transferred from the installation vessel and secured to the production platform.

In order to attach the riser conduit to the skid 7, the riser conduit 5 is connected to a wellhead 12 which is held vertically and is pivotally attached to the skid 7 as shown in FIG. 2 and FIG. 3B about an axis 13 so as to be movable through an angle of 90° as demonstrated by the arrow 14. The wellhead has a swivel telescopic section 12A which is locked during the installation process at mid-stroke and is unlocked once the system is installed to allow for riser conduit twist and thermal expansion. This allows not only for the third installation method described above where the wellhead 12 will initially have to be vertical, but also allows for the oblique riser conduit 5B as illustrated in FIG. 1. The riser conduit 5 is landed within the wellhead 7 and is sealed by pressure seals 15.

The next stage is to drill from the wellhead 12 into the seabed 6 and to install a conductor. Depending on the surface formation a hole can be drilled and a conductor can be installed, or the conductor 16 can be run with an internal shoe bit rotated by a drill string turbine. This latter arrangement can be used in order to drill through unconsolidated formations close to the surface of the seabed so that the conductor 16 supports the formation where a drilled hole would collapse during drilling. In the case of the riser conduit 5B the conductor 16 will follow the angle of the riser conduit into the seabed, while for the horizontal arrangement as shown in FIGS. 2 and 3B the conductor will initially be horizontal but will drop angle under gravity so that it continues obliquely downwardly through the seabed to the desired depth. The conductor 16 is provided with a stop which lands in the wellhead 12 at which point the internal shoe bit is removed and conventional drilling techniques can be used to install a intermediate string 17, a production casing string 18, both of which are landed and sealed within the wellhead 12, and a liner or screens 10.

The drilling elements can be provided with a system of rollers which may be driven in order to facilitate their rotation and passage down the riser conduit. It may even be useful to provide hydraulic force to the drilling or to the casing running systems to provide movement along the riser conduit 5, particularly where the riser conduit has a long horizontal portion.

The appropriate tie back casings 19, 20 are hung off at the production deck and landed within the wellhead 12 in a similar manner as for conventional vertical tieback wellheads.

The well completion tubing 21 is now run from the production installation all the way to the production formation. Alternatively, the completion tubing can be hung off in the wellhead 12. The completion tubing can be provided with two surface control safety valves 22, 23.

By using the tie back strings and landing the production tubing in the wellhead 12, it is possible to perform a disconnect operation above the wellhead 12 after the well is made safe. To facilitate reconnection, the skid can have a horizontal pipeline pull in system. Alternatively if it is envisaged that the conductor will never need to be discon-

5

nected the intermediate casing string and the production casing string can be run directly up to the production platform without landing in the skid wellhead **12**.

At the production deck, a BOP (not shown) is removed and a tree **24** of known construction is installed for production. In this case, a horizontal tree is shown which has the tubing run through it and landed in it.

A second example of an assembly is shown in FIG. **4**. The only difference between this assembly and that shown in FIG. **1** relates to the nature of the production installation. Instead of a tension leg production installation at the surface as shown in FIG. **1**, the example of FIG. **4** has a tension leg subsurface platform **25** which is positioned at a relatively short distance below the surface **2** and connected to a mobile drilling vessel **26** by a short drilling riser **27**. The mobile drilling vessel can be moved between wellheads **28** together with a drilling BOP **29** and can thus be used to drill a number of wells. In this case, the drilling riser is vertical at the subsurface platform **25**.

What is claimed is:

1. An offshore wellhead assembly for a well extending into a seabed comprising:

a production deck at a predetermined position;
a plurality of riser conduits vertically suspended from the production deck, the well being drilled, completed and produced through one of said riser conduits;
the one of said riser conduits deviating progressively further from the vertical with increasing sea depth; and
the one of said deviating riser conduits being secured at an angle to the vertical at the seabed by a fixture with the well extending into the seabed from the fixture.

2. A assembly according to claim **1**, wherein the riser conduit is attached by the fixture at a oblique angle to the vertical, and the well extends into the seabed at the same oblique angle.

3. An assembly according to claim **2**, wherein the riser conduit is pivotally mounted to the fixture.

4. An assembly according to claim **2**, wherein the fixture is in the form of a skid which is to be fixed to the seabed so that each riser conduit is secured to the seabed by a separate skid.

5. An assembly according to claim **1**, wherein the fixture is in the form of a skid which is to be fixed to the seabed so that each riser conduit is secured to the seabed by a separate skid.

6. An offshore wellhead assembly comprising
a production deck at which a riser conduit is vertically suspended,
the riser conduit deviating progressively further from the vertical with increasing sea depth,
the riser conduit being secured at an angle to the vertical at the seabed by a fixture,
a cased well extending into the seabed from the fixture, wherein, at the seabed, the riser conduit is horizontal and extends across the seabed to the fixture and said riser conduit is used, at least, in drilling and producing a well.

7. An assembly according to claim **6**, wherein the riser conduit is pivotally mounted to the fixture and said cased well extends into the seabed at an angle to the vertical.

8. An assembly according to claim **6**, wherein the fixture is in the form of a skid which is to be fixed to the seabed so that each riser conduit is secured to the seabed by a separate skid.

6

9. An offshore wellhead assembly comprising
a production deck at which a multipurpose riser conduit is vertically suspended,

the multipurpose riser conduit deviating progressively further from the vertical with increasing sea depth,
the multipurpose riser conduit being secured at an angle to the vertical at the seabed by a fixture,

a cased well extending into the seabed from the fixture at an angle to the vertical, wherein the multipurpose riser conduit is pivotally mounted to the fixture.

10. An assembly according to claim **9**, wherein the fixture is in the form of a skid which is to be fixed to the seabed.

11. An offshore system for one or more wells extending through the seabed, comprising:

a production platform at a predetermined geographic position;

a plurality of riser conduits vertically suspended from the production platform, each of the one or more wells being drilled, completed, and produced through one of the plurality of riser conduits;

the riser conduits deviating progressively further from the vertical with increasing sea depth;

a plurality of fixtures at the seabed; and

each of said riser conduits being secured at an angle to the vertical at the seabed by a fixture.

12. The system according to claim **11**, wherein each fixture is in the form of a skid which is to be fixed to the seabed.

13. An offshore system for one or more wells extending through the seabed, comprising:

a production platform at a predetermined geographic position;

a plurality of riser conduits vertically suspended from the production platform, wherein a well is drilled, completed, and produced through a single riser conduit;

the riser conduits deviating progressively further from the vertical with increasing sea depth;

a plurality of fixtures at the seabed; and

each of said riser conduits being secured at an angle to the vertical at the seabed by a fixture, wherein each riser conduit is pivotally mounted to its fixture and the wells extend into the seabed at an angle to the vertical wherein said riser conduit is capable of pivoting up to an angle of 90 degrees from a position in which the riser conduit is perpendicular to the base of the fixture.

14. An offshore system for drilling, completion, and production of a plurality of subsea wells extending into the seabed at an angle from vertical, comprising:

a substantially stationary production platform at which a riser conduit is vertically suspended for each well, wherein the wells are drilled, completed, and produced through said riser conduits;

each riser conduit deviating progressively further from the vertical with increasing sea depth so that at the seabed, the riser conduit is substantially horizontal;

a plurality of fixtures at the seabed; and

each riser conduit being secured at the seabed by a fixture with each well extending into the seabed from a different fixture.

15. The system according to claim **14**, wherein each riser conduit is pivotally mounted to the fixture and the wells extend into the seabed at an angle to the vertical.

16. The system according to claim 14, wherein each fixture is in the form of a skid which is to be fixed to the seabed.

17. An offshore wellhead assembly for drilling, completion, and production of at least two subsea wells extending into the seabed at an angle, comprising:

a substantially stationary production deck at which first and second riser conduits are vertically suspended, wherein the wells are drilled, completed, and produced through said riser conduits;

said riser conduits deviating progressively further from the vertical with increasing sea depth so that, at the seabed,

said riser conduits being substantially horizontal; and

said first and second riser conduits being secured at the seabed by first and second fixtures, respectively, with the wells extending into the seabed from each fixture.

18. The system according to claim 17, wherein the riser conduit is pivotally mounted to the fixture and the wells extend into the seabed at an angle to the vertical.

19. The system according to claim 17, wherein the fixture is in the form of a skid which is to be fixed to the seabed.

20. An offshore wellhead assembly for a well extending into a seabed comprising:

a production deck at a predetermined position;

a riser conduit vertically suspended from the production deck and through which the well is drilled, completed and produced;

the riser conduit deviating progressively further from the vertical with increasing sea depth; and

the riser conduit being secured at an angle to the vertical at the seabed by a fixture with the well extending into the seabed from the fixture, wherein, at the seabed, the riser conduit is horizontal.

* * * * *