



US006408594B1

(12) **United States Patent**
Porter

(10) **Patent No.:** **US 6,408,594 B1**
(45) **Date of Patent:** **Jun. 25, 2002**

(54) **REINFORCED STRUCTURAL INSULATED
PANELS WITH PLASTIC IMPREGNATED
PAPER FACINGS**

(76) Inventor: **William H. Porter**, P.O. Box 249,
Saugatuck, MI (US) 49453

(*) Notice: Subject to any disclaimer, the term of this
patent is extended or adjusted under 35
U.S.C. 154(b) by 0 days.

4,712,352 A	*	12/1987	Low	52/809
4,726,973 A		2/1988	Thompson	
4,765,105 A		8/1988	Tissington et al.	
4,786,547 A		11/1988	St-Michel	
4,856,244 A		8/1989	Clapp	
4,865,912 A		9/1989	Mitsumata	
4,932,171 A		6/1990	Beattie	
5,058,333 A		10/1991	Schwartz	
5,062,250 A		11/1991	Buzzella	

(List continued on next page.)

(21) Appl. No.: **09/334,233**

(22) Filed: **Jun. 16, 1999**

(51) **Int. Cl.**⁷ **E04C 2/34**

(52) **U.S. Cl.** **52/794.1; 52/220.1; 52/268;**
52/270; 52/309.7; 52/309.11; 52/586.1

(58) **Field of Search** **52/236.7, 262,**
52/265, 267, 268, 269, 270, 275-279, 437-439,
309.7, 309.11, 309.14, 309.16, 574, 586.1,
590.2, 592.2, 220.1, 20.3

(56) **References Cited**

U.S. PATENT DOCUMENTS

919,057 A	4/1909	Moore
1,250,594 A	12/1917	Knapp
2,111,922 A	3/1938	Borkenstein
2,875,478 A	3/1959	Andre
3,557,840 A	1/1971	Maybee
3,654,053 A	4/1972	Toedter
3,731,449 A	5/1973	Kephart, Jr.
3,911,554 A	10/1975	Ford
4,024,684 A	5/1977	Holmgren
4,037,377 A	7/1977	Howell et al.
4,051,641 A	10/1977	Elliott
4,068,437 A	1/1978	Byxbe et al.
4,147,004 A	4/1979	Day et al.
4,169,688 A	10/1979	Toshio
4,170,859 A	10/1979	Counihan
4,402,170 A	9/1983	Seidner
4,430,833 A	2/1984	Balzer et al.
4,443,988 A	4/1984	Coutu, Sr.
4,471,591 A	9/1984	Jamison
4,671,038 A	6/1987	Porter
4,704,837 A	11/1987	Menchetti et al.

Primary Examiner—Carl D. Friedman

Assistant Examiner—Yvonne M. Horton

(74) *Attorney, Agent, or Firm*—Emrich & Dithmar

(57) **ABSTRACT**

A structural insulated panel for building construction includes a planar, rigid insulating core such as of lightweight plastic foam having opposed surfaces to which are bonded respective plastic impregnated paper (PIP) sheets. Disposed symmetrically either on the inner surfaces of the PIP sheets, and thus within the panel's insulating foam core, or on the outer surfaces of the PIP sheets are spaced reinforcing strips. The reinforcing strips may be flat or formed, such as in the shape of a channel, may be of metal, gypsum composites, or wood, and are provided with an adhesive coating for bonding to the insulating foam core and a PIP sheet. The spaced metal strips increase the panel's bending strength and serve as an attachment base for internal and external finished faces, while the PIP sheets provide the panel with high tensile strength. The adhesive coating on the metal reinforcing strips further increases panel strength. The metal strips may also be provided with an outer gypsum coating to protect the metal strip from heat and/or fire. The panels may be used in walls, roofs or floors. When used in a wall, top and bottom U-shaped metal channels may be respectively positioned on upper and lower edges of the panel and attached to respective upper and lower edges of the reinforcing strips within the panel by conventional means such as screws. Adjacent panels may be joined by metal strips attached such as by screws or clips to the panels' top and bottom edge channels.

39 Claims, 5 Drawing Sheets

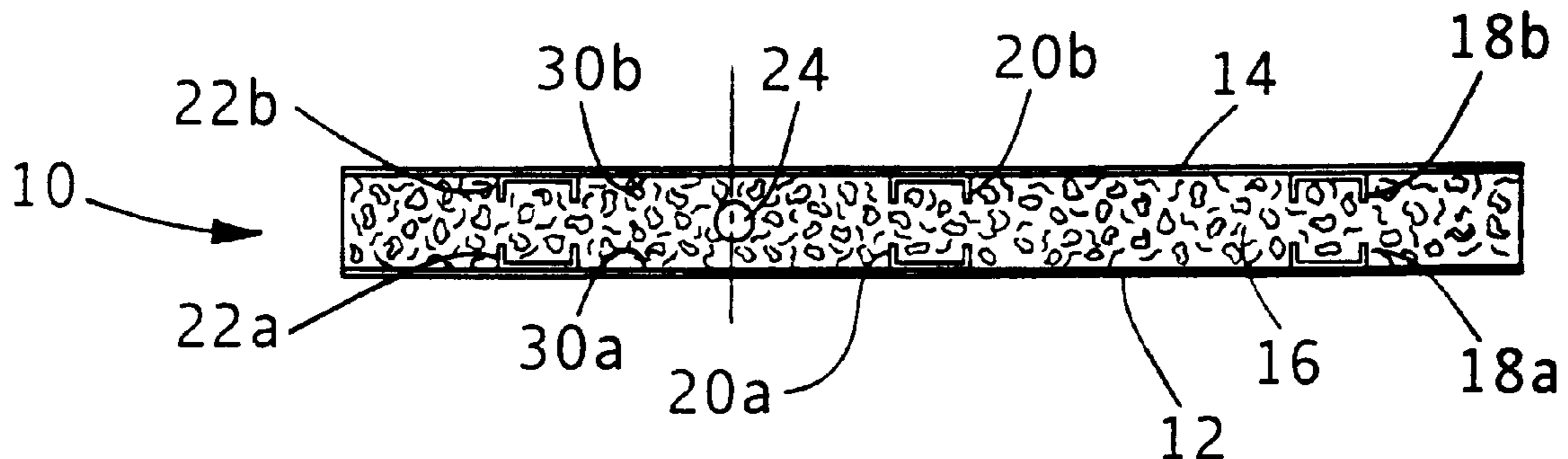

US 6,408,594 B1

Page 2

U.S. PATENT DOCUMENTS

5,081,810 A	1/1992	Emmert	5,842,314 A	12/1998	Porter
5,140,086 A	8/1992	Hunter et al.	5,950,389 A	9/1999	Porter
5,345,738 A	9/1994	Dimakis	5,953,883 A	9/1999	Ojala
5,428,929 A	7/1995	Reese	6,041,562 A *	3/2000	Martella et al. 52/236.7
5,497,589 A	3/1996	Porter	6,136,408 A *	10/2000	Radcliffe et al. 428/107
5,628,158 A	5/1997	Porter	6,205,729 B1 *	3/2001	Porter 52/309.7
5,638,651 A	6/1997	Ford	6,209,284 B1 *	4/2001	Porter 52/794.1
5,743,056 A *	4/1998	Balla-Goddard et al. 52/309.11	6,269,608 B1 *	8/2001	Porter 52/794.1
5,771,645 A *	6/1998	Porter 52/220.1	6,308,491 B1 *	10/2001	Porter 52/794.1
5,815,989 A *	10/1998	Bennenk et al. 52/80.1			

* cited by examiner

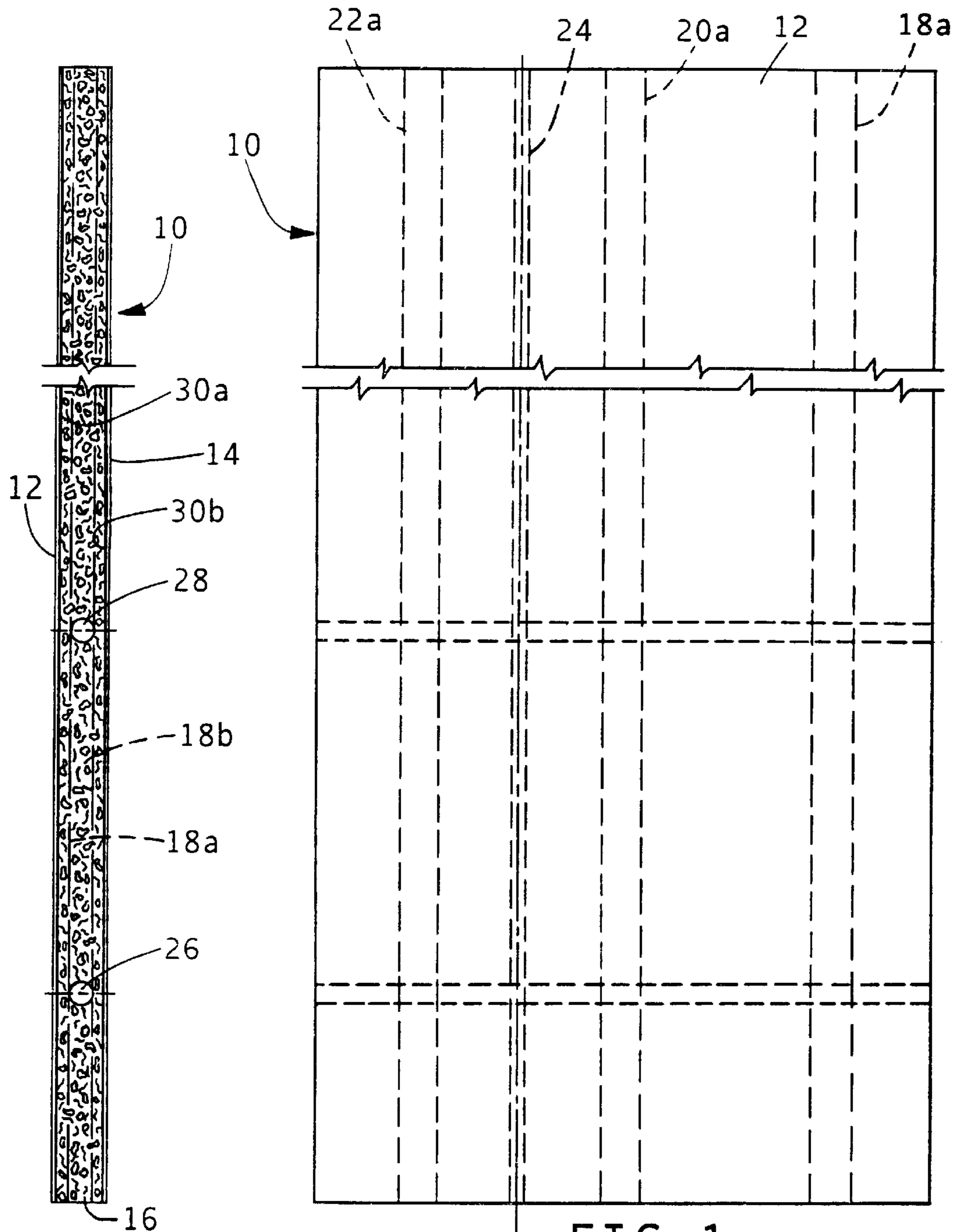

FIG. 1

FIG. 3

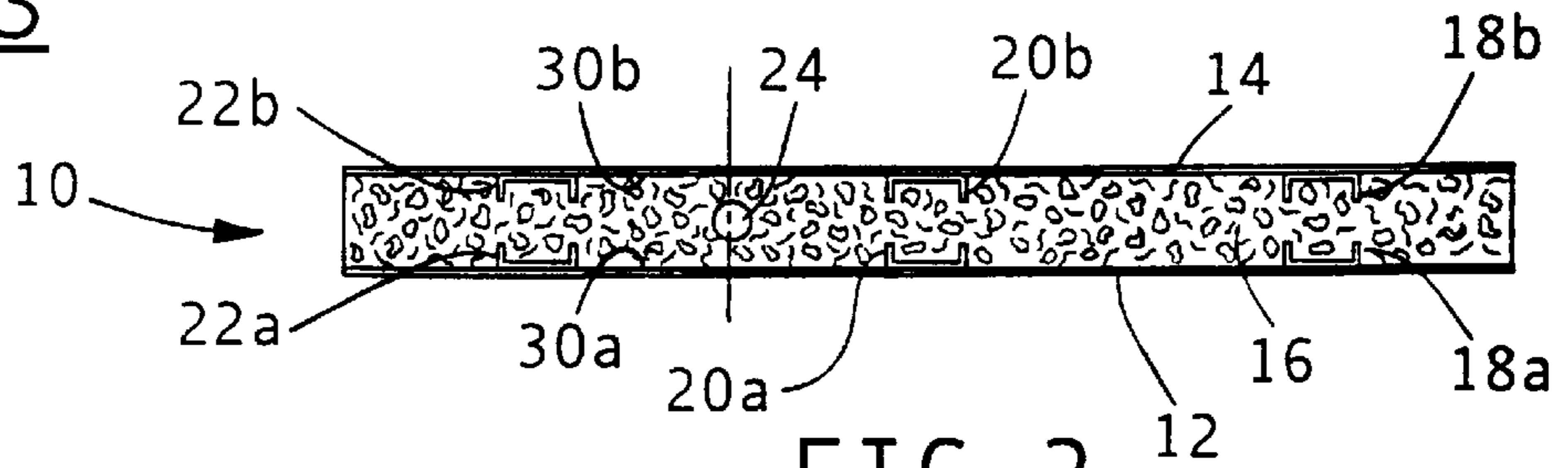

FIG. 2

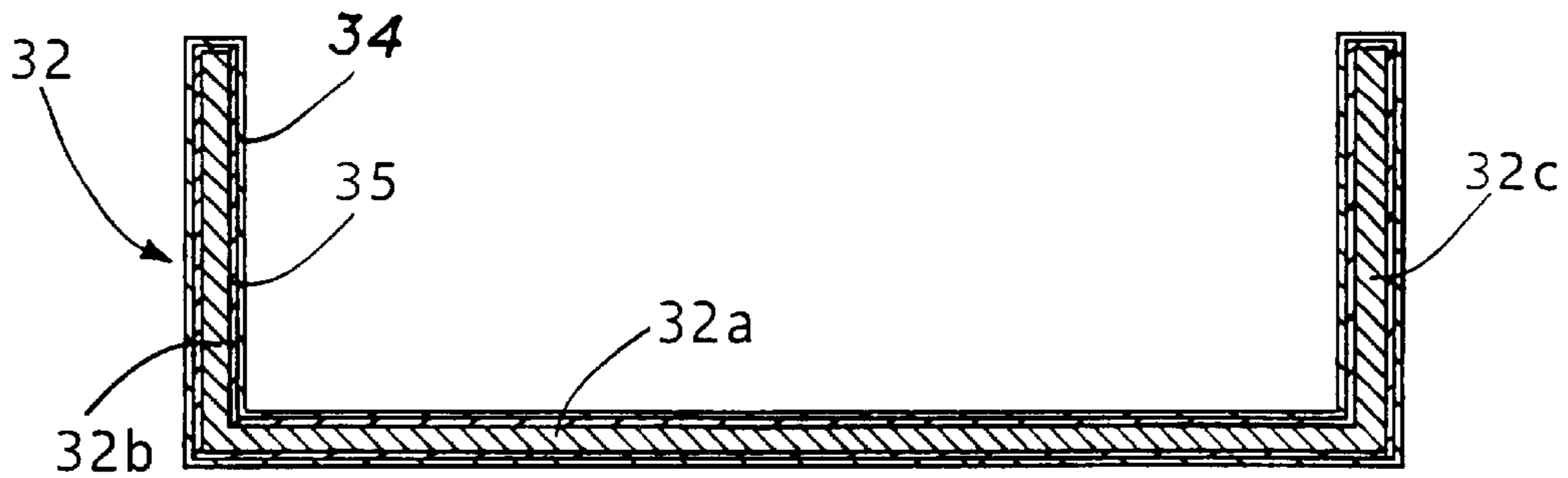

FIG. 1a

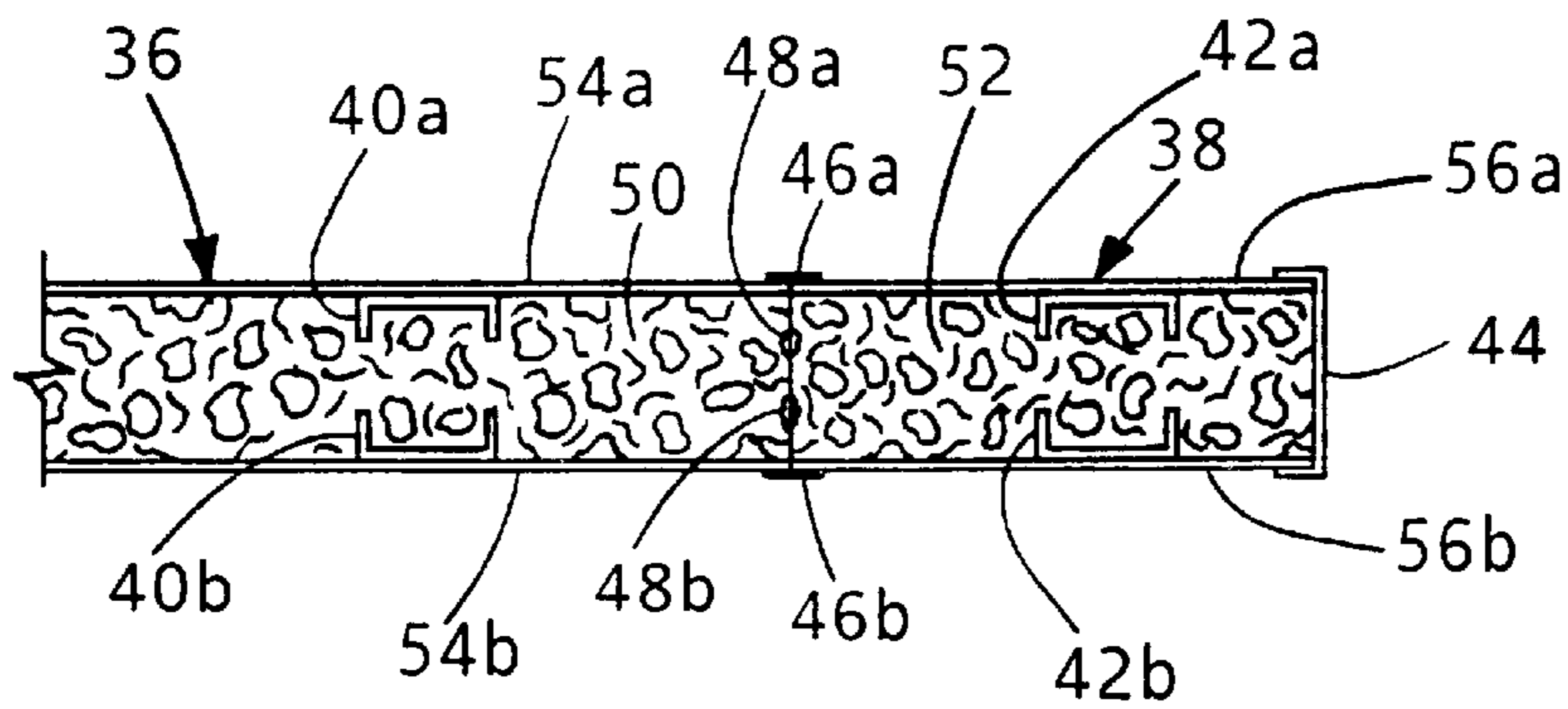

FIG. 4

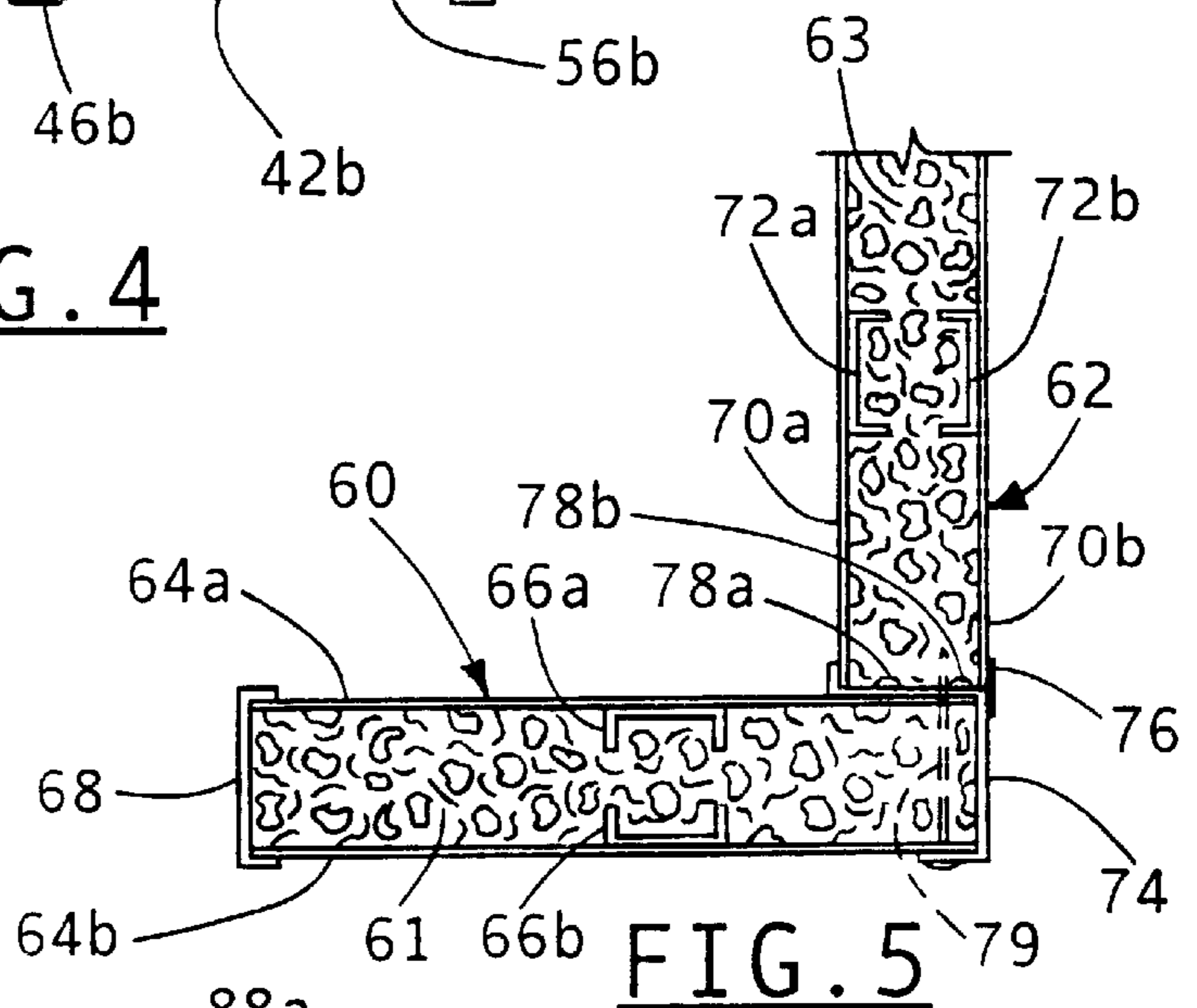

FIG. 5

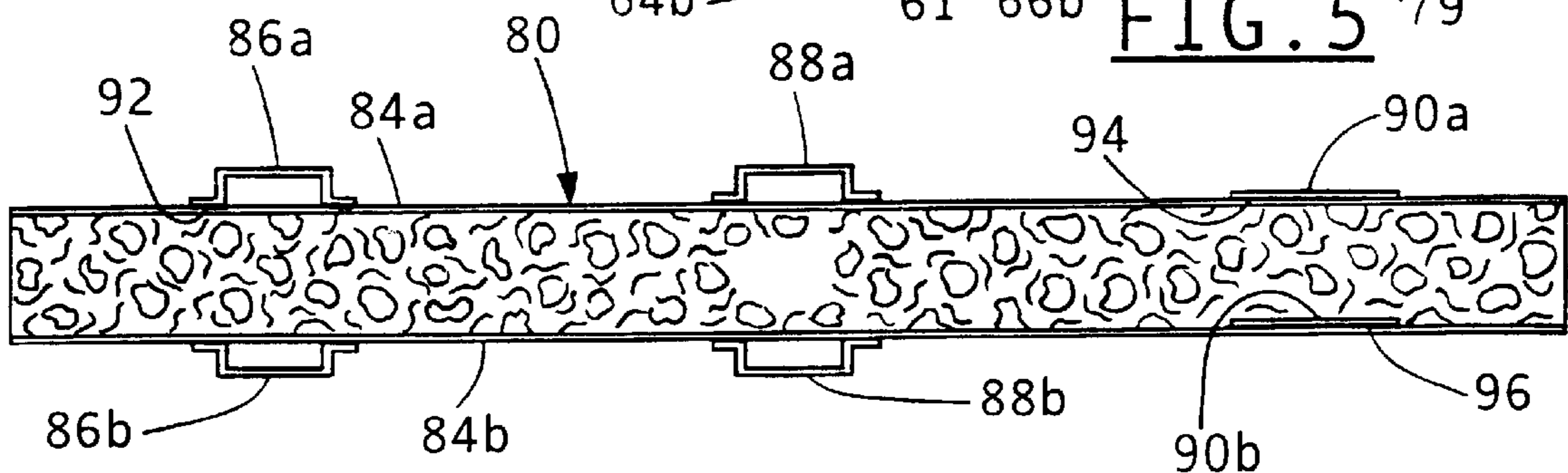

FIG. 6

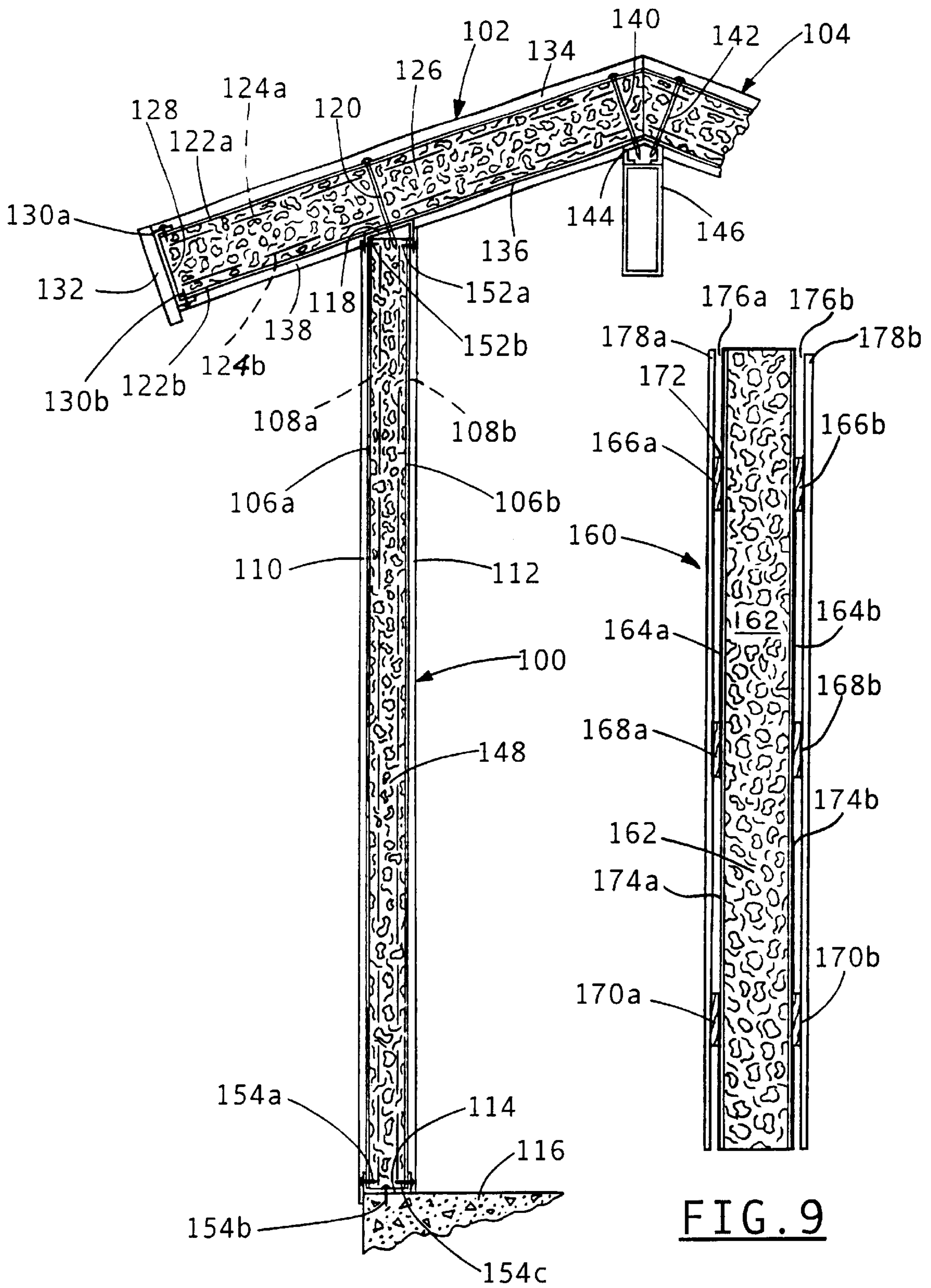

FIG. 7

FIG. 9

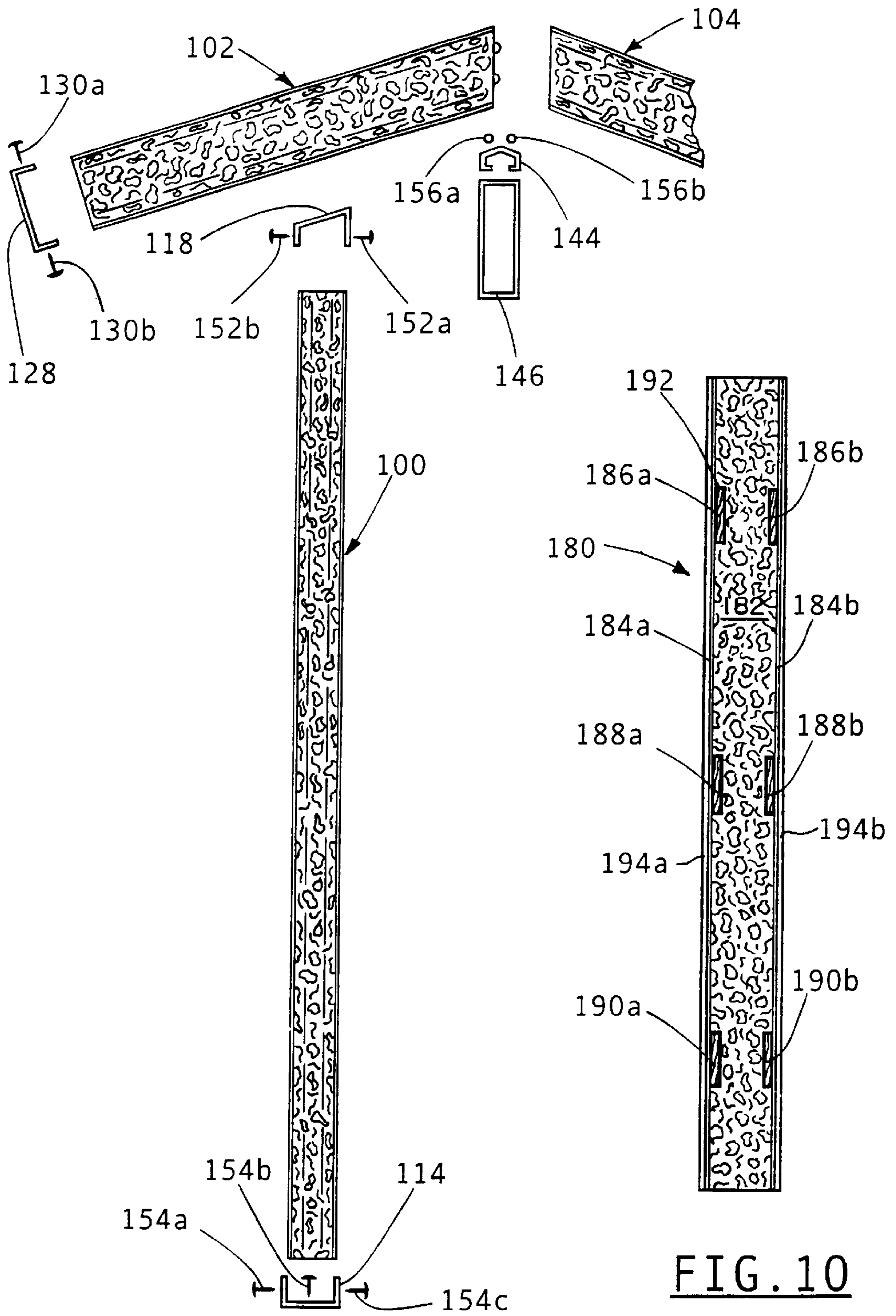

FIG. 8

FIG. 10

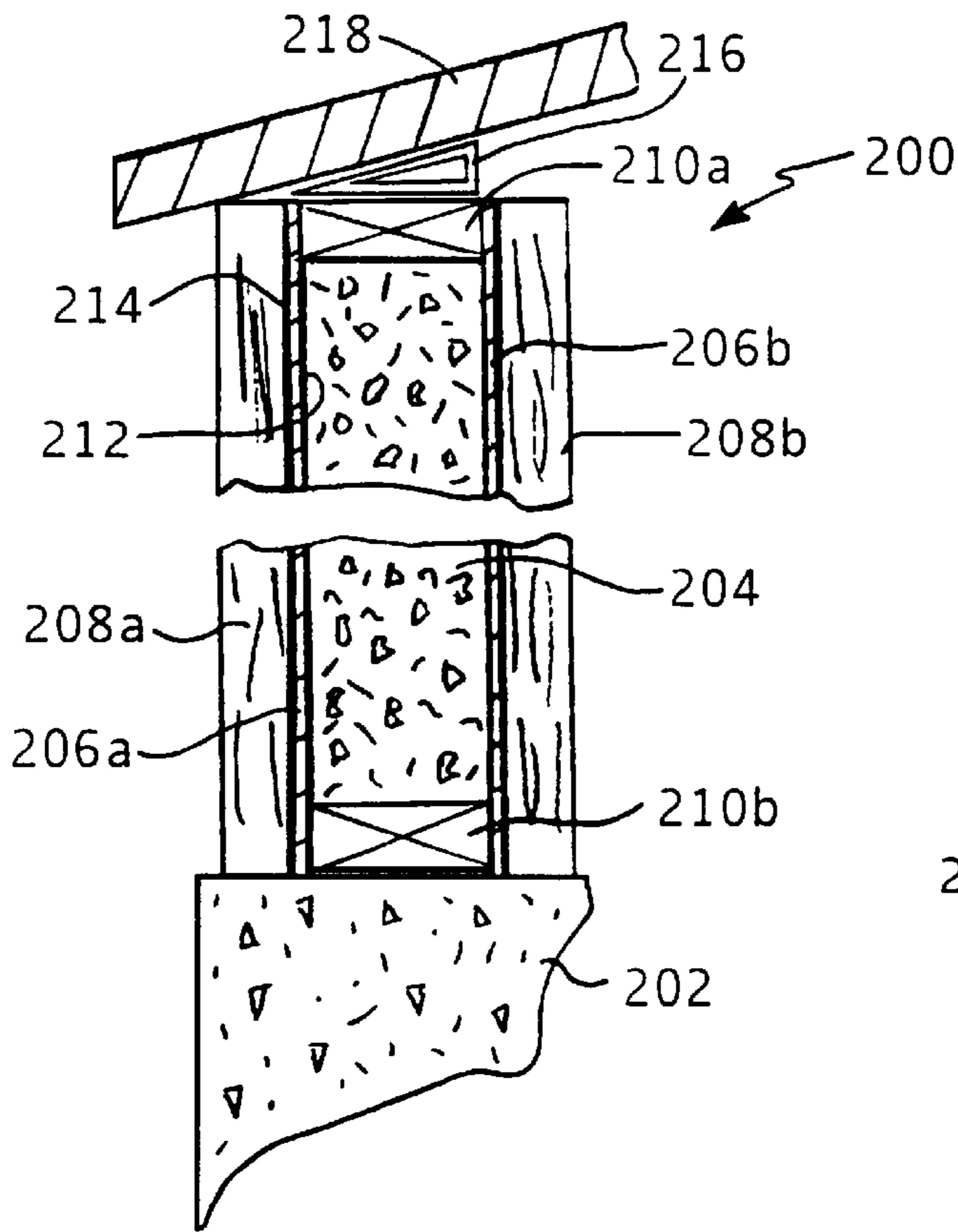

FIG. 11

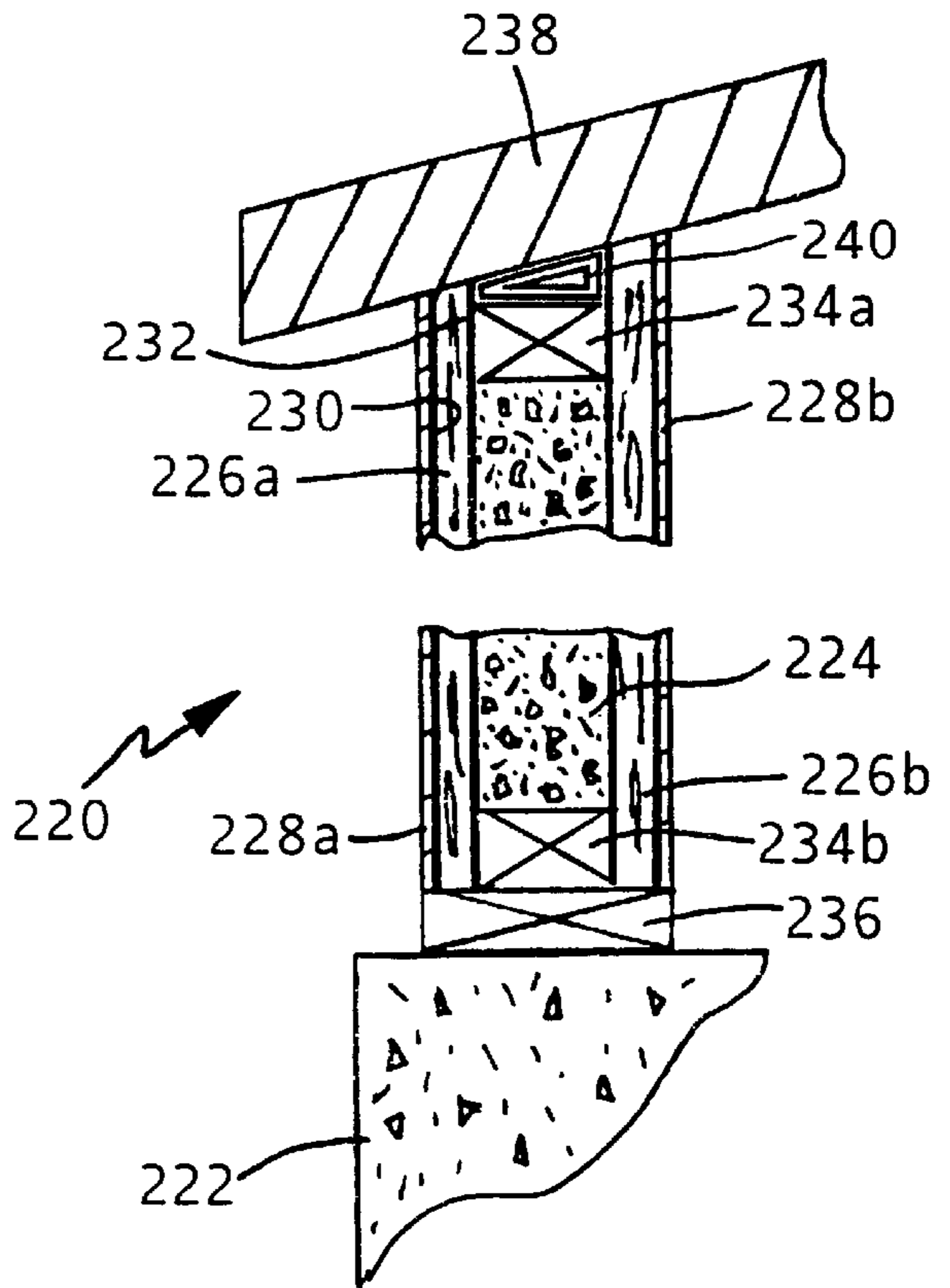

FIG. 12

REINFORCED STRUCTURAL INSULATED PANELS WITH PLASTIC IMPREGNATED PAPER FACINGS

FIELD OF THE INVENTION

This invention relates generally to structural insulated panels such as used in building construction and is particularly directed to a rigid flat panel having an insulating core, first and second opposed outer facings having high tensile strength, and reinforcing strips attached to either the inner or outer surface of one or both of the panel's facings.

BACKGROUND OF THE INVENTION

Lumber stick construction commonly used in the construction of most homes and small to medium sized structures employs 2X dimensional structural lumber members and nails for joining the lumber members. The stick built approach requires assembly and joining of the lumber members by hand and is thus manpower intensive. In addition, the lumber products used are seldom straight, warp with moisture, creep under a load, and are of inconsistent quality. Moreover, lumber cannot withstand high point loading and is thus of limited structural strength. Finally, 2X dimensional structural lumber members form thermal bridges in exterior walls and roofs and thus are not energy efficient.

The present invention addresses the aforementioned limitations of the prior art by providing a metal reinforced structural insulated panel having a lightweight insulating core and first and second opposed outer facings attached to the core and comprised of plastic impregnated paper for high tensile strength. The panel incorporates reinforcing strips such as of either metal or wood bonded to inner or outer surfaces of the outer facings to accommodate large axial, transverse and compression loads.

OBJECTS AND SUMMARY OF THE INVENTION

Accordingly, it is an object of the present invention to provide a structural insulated panel capable of withstanding large tensile, bending, compression, axial and racking loads which is of simple construction and easy to install.

It is another object of the present invention to provide a structural insulated panel having an insulating foam core with high tensile strength outer facings and wood or metal reinforcing strips attached to either an outer surface of a facing or to an inner surface of a facing and the insulating foam core to accommodate large axial, transverse and compression loads.

Yet another object of the present invention is to provide a structural insulated panel with internal reinforcing strips and upper and lower metal edge caps connected respectively to the upper and lower ends of the reinforcing strips for facilitating attachment of the panel to a foundation or floor and a ceiling or roof.

This invention contemplates a reinforced, insulated structural panel comprising a generally flat insulating core having first and second opposed sides; first and second sheets of plastic impregnated paper respectively disposed on the first and second sides of the insulating core for providing the panel with high tensile strength; first and second elongated, linear structural members respectively disposed in contact with the first and second sheets of plastic impregnated paper and extending substantially the entire length of the panel for increasing the bending strength of the panel; and adhesive means disposed on the first and second structural members

for respectively bonding the first and second structural members to said first and second sheets of plastic impregnated paper.

BRIEF DESCRIPTION OF THE DRAWINGS

The appended claims set forth those novel features which characterize the invention. However, the invention itself, as well as further objects and advantages thereof, will best be understood by reference to the following detailed description of a preferred embodiment taken in conjunction with the accompanying drawings, where like reference characters identify like elements throughout the various figures, in which:

FIG. 1 is a plan view shown partially in phantom of a metal reinforced structural insulated panel with plastic impregnated facings in accordance with the principles of the present invention;

FIG. 1a is a transverse sectional view of one embodiment of a metal reinforcing member used in the structural insulated panel of the present invention;

FIG. 2 is a top plan view of the metal reinforced structural insulated panel of FIG. 1;

FIG. 3 is a side elevation view shown partially in phantom of the metal reinforced structural insulated panel shown in FIGS. 1 and 2;

FIG. 4 is a partial top plan view of a pair of metal reinforced structural insulated panels which are connected together in accordance with another aspect of the present invention;

FIG. 5 is a partial top plan view of another embodiment of a pair of connected metal reinforced structural insulated panels in accordance with the present invention;

FIG. 6 is a top plan view of another embodiment of a structural insulated panel in accordance with the present invention showing the metal reinforcing members disposed on the outer surface of the panel's opposed facings;

FIG. 7 is a side elevation view shown partially in phantom of a metal reinforced structural insulated panel attached at its lower end to a foundation or floor and at its upper end to a roof panel in accordance with another aspect of the present invention;

FIG. 8 is an exploded view of the metal reinforced structural insulated panel installation arrangement of FIG. 7;

FIGS. 9 and 10 are top plan views of additional embodiments of the present invention incorporating reinforcing strips comprised of wood; and

FIGS. 11 and 12 are sectional views of additional installations for a structural insulated panel in accordance with other aspects of the present invention.

DETAILED DESCRIPTION OF THE PREFERRED EMBODIMENTS

Referring to FIGS. 1, 2 and 3, there are respectively shown front elevation, top planar and side elevation views of a metal reinforced structural insulated panel 10 in accordance with one embodiment of the present invention. FIGS. 1 and 3 are shown partially in phantom to illustrate internal components within the structural insulated panel 10.

Structural panel 10 includes an inner, rigid insulating core 16 preferably comprised of a plastic foam such as of expanded polystyrene or urethane. The insulating core 16 may also be made from an agricultural product such as strawboard. Structural panel 10 further includes first and second outer facings 12 and 14 attached to respective

opposed surfaces of the panel's insulating core 16. Each of the first and second outer facings 12,14 is preferably comprised of paper or box board impregnated with urethane or polyisocyanurate plastic. This plastic impregnated paper is commercially available from Weyerhaeuser and is sold under the trade name of P-CELL. The plastic impregnated paper sheet facings 12,14 offer several advantages. For example, the plastic impregnated paper sheets serve as a vapor barrier near the outer and inner surfaces of an exterior wall or roof deck to prevent moisture from entering the insulating core 16 of the structural panel 10 from either the outside environment or from an inside room of a building structure. Moisture passing through the structural insulated panel 10 may result in a loss of moisture from the interior of the building structure, reducing the comfort level of occupants of the building structure. The introduction of moisture into the interior of the structural panel 10 will also eventually result in degradation of the panel structure. The plastic impregnated paper composition of the first and second outer facings 12,14 also substantially increases the tensile strength of the structural insulated panel 10. The plastic impregnated paper sheets attached to the panel's insulating core 16 enable the panel to withstand large transverse loads when the plastic impregnated paper sheet/outer facing side of the panel is in tension. Adhesive layers 30a and 30b respectively disposed on inner surfaces of the first and second outer facings 12,14 securely attach the plastic impregnated paper sheet to the panel's insulating core 16. The adhesive layers 30a,30b may be of conventional composition such as urethane cement, glue or an epoxy resin.

Disposed within the panel's insulating core 16 and in contact with and bonded to the inner surfaces of the first and second outer facings 12,14 are a plurality of spaced metal reinforcing channels. Thus, metal reinforcing channels 18a, 20b and 22a are disposed within the panel's insulating core 16 and are bonded to the inner surface of the panel's first outer facing 12. Similarly, metal reinforcing channels 18b, 20b and 22b are disposed within the panel's insulating core 16 and are bonded to the inner surface of the panel's second outer facing 14. While the metal reinforcing members are shown having a shaped channel form, each of these metal reinforcing members may equally as well be flat in cross section as described below. Each of the metal reinforcing channels is formed from sheet metal such as steel or aluminum. The metal reinforcing channels substantially increase the bending strength of the panel particularly along its length. Insulated structural panels incorporating metal reinforcing channels in accordance with the present invention exhibit an increase in bending strength of at least 40% over non-reinforced structural panels. Structural panel 10 further includes a plurality of electrical chases 24, 26 and 28 extending through the panel's insulating core 16 for receiving electrical wiring (not shown for simplicity). The first, second and third electrical chases 24, 26 and 28 are formed in the panel's insulating core 16 by conventional means such as described in applicant's U.S. Pat. No. 5,771,645.

Referring to FIG. 1a, there is shown a traverse sectional view of a metal reinforcing channel 32 such as used in the disclosed embodiment of the present invention. Metal reinforcing channel 32 includes a center section 32a and first and second end sections 32b and 32c. Disposed on the surface of the metal reinforcing channel 32 is a gypsum layer 35 to protect the metal member from excessive heat such as from a fire. Disposed on the gypsum layer 35 is an adhesive coating 34 for bonding to the panel's insulating foam core and one of its plastic impregnated paper outer facings. Secure bonding between these components of the structural

insulated panel substantially increase the panel's strength. Any conventional adhesive coating 34 may be used on the surface of the metal reinforcing channel 32 such as urethane or epoxy cement, glue or a mastic coating.

Referring to FIG. 4, there is shown a top plan view of an arrangement for connecting first and second structural insulated panels 36 and 38 in accordance with another aspect of the present invention. As in the previously described embodiment, the first structural insulated panel 36 includes an insulating plastic foam core 50 and first and second outer plastic impregnated paper facings 54a and 54b attached to opposed surfaces of the foam core. Disposed within and bonded to the foam core 50 as well as to the first and second outer facings 54a,54b are first and second metal reinforcing channels 40a and 40b, respectively. Similarly, the second structural insulated panel 38 includes an insulating plastic foam core 52 and first and second plastic impregnated paper outer facings 56a and 56b adhered to opposed surfaces of the foam core. Disposed within the second panel's foam core 52 and respectively bonded to the panel's first and second outer facings 56a,56b are first and second metal reinforcing channels 42a and 42b. Attached to a lateral edge of the second structural insulated panel 38 is an edge cap 44 preferably comprised of metal which is affixed to the panel by conventional adhesive means. The metal edge cap 44 would be attached to a vertical edge of the second panel 38 such as when the first and second panels form a wall so as to define a doorway or window opening in the wall.

Adjacent edges of the first and second structural insulated panels 36,38 are securely connected together by means of first and second mastic strips 48a and 48b. Mastic strips 48a,48b are applied to the insulating core of either of the panels and the first and second structural insulated panels 36,38 are then placed in edge-abutting contact and the mastic strips are allowed to cure. First and second tape strips 46a and 46b each having a respective adhesive surface are then applied over the seams in the outer facings of the joined panels to form a vapor seal at the juncture of the two panels.

Referring to FIG. 5, there is shown partially in phantom a top plan view of another arrangement for securely connecting adjacent first and second structural insulated panels 60 and 62 forming adjacent wall sections in accordance with another aspect of the present invention. As in the previously described embodiments, the first structural panel 60 includes an insulating core 61 having facing surfaces to which are respectively bonded first and second outer facings 64a and 64b. Disposed within and attached to the insulating core 61 and affixed respectively to the first and second outer facings 64a,64b are first and second metal reinforcing channels 66a and 66b. Attached to a vertical edge of the first structural panel 60 by conventional adhesive means is a metal edge cap 68. The second structural panel 62 similarly includes an insulating core 63 having opposed surfaces to which are respectively attached first and second outer facings 70a and 70b. Disposed within and attached to the insulating core 63 and affixed respectively to the first and second outer facings 70a,70b are first and second metal reinforcing channels 72a and 72b.

Adjacent vertical edges of the first and second structural panels 60 and 62 are securely connected together in the following manner. A metal edge connecting channel 74 is configured so as to engage adjacent vertical edges of the first and second structural panels 60,62. Respective linear portions of the edge connecting channel 74 are positioned over each panel's foam core and extend between the opposed outer facings of the panel. Thus, a first linear portion of the edge connecting channel 74 extends between the first and

second outer facings **64a,64b** of the first structural panel **60** and covers the lateral edge of the panel's insulating core **61**. A second linear portion of the edge connecting channel **74** extends between the second structural panel's first and second outer facings **70a,70b** and covers the lateral edge of the panel's insulating core **63**. First and second mastic strips **78a** and **78b** are deposited between the edge of the second structural panel's insulating core **63** and the edge connecting channel **74**. The mastic strips **78a,78b** form a secure bond of high strength between the first and second structural panels **60,62**. A connecting pin **79** such as a screw (shown in dotted line form) is inserted through parallel, spaced portions of the edge connecting channel **74** as well as through the first structural panel's first and second outer facings **64a,64b** and insulating core **61** and into the second panel's insulating core **63**. The first and second mastic strips **78a,78b** preferably extend the full length of each of the first and second structural panels **60,62**. Similarly, additional connecting pins may be arranged in a spaced manner and inserted through the edge connecting channel **74** and the first structural panel **60** and into the second structural panel **62** for connecting the two panels along their respective lengths. An adhesive-backed tape **76** is positioned over the seam between the second structural panel's second outer facing **70b** and the adjacent portion of the edge connecting channel **74** to form a vapor seal between the two panels.

Referring to FIG. 6, there is shown another embodiment of a structural insulated panel **80** in accordance with the present invention. Structural insulated panel **80** includes an insulating foam core **82** and first and second opposed plastic impregnated paper outer facings **84a** and **84b**. Affixed to the outer surfaces of each of the first and second outer facings **84a,84b** are first and second pairs of metal reinforcing channels **86a,88a** and **86b,88b**, respectively. Each of the four metal reinforcing channels is in the shape of a "hat" and is attached to the outer surface of a respective outer facing by means of an adhesive layer **92**.

Structural insulated panel **80** is further shown in FIG. 6 as incorporating metal reinforcing members **90a** and **90b**. Each of the metal reinforcing members **90a,90b** is in the form of a thin, flat strip. Metal reinforcing member **90b** is bonded to the panel's insulating foam core **82** as well as to the inner surface of its second outer facing **84b** by means of an adhesive layer **96**. Similarly, metal reinforcing member **90a** is affixed to the outer surface of the panel's first outer facing **84a** by means of an adhesive layer **94**. Metal reinforcing members extending the length of the panel may thus be in the form of a thin, flat strip of a metal such as steel or aluminum and may be bonded to either the inner or outer surfaces of either one or both of the panel's outer facings.

Referring to FIG. 7, there is shown a side elevation view shown partially in phantom of a metal reinforced structural insulated panel **100** attached at its lower end to a foundation or floor **116** and at its upper end to a roof panel **102** in accordance with another aspect of the present invention. Structural panel **100** is incorporated in a building structure as an exterior wall panel and, as in the previously described embodiments, includes first and second plastic impregnated paper outer facings **106a** and **106b** and an insulating core **148** disposed between and bonded to the two outer facings. Also disposed within the structural panel **100** and bonded to its insulating core **148** and its first and second outer facings **106a,106b**, respectively, are first and second reinforcing members **108a,108b** (shown in dotted line form). Each of the first and second reinforcing members **108a,108b** may be either in the form of a flat strip or a shaped member such as a channel as previously described. Structural panel **100**

typically would include several spaced reinforcing members adjacent its inner and outer surfaces. Attached to the panel's second outer facing **106b** is an interior drywall sheet **112**, while attached to the panel's first outer facing **106a** is exterior siding **110**. The drywall sheet **112** and the exterior siding **110** may be attached to respective facing portions of the structural panel **100** by conventional means such as nails or a high strength adhesive.

Attached to a lower end of the structural panel **100** is a base channel, or cap, **114**. Base channel **114** is preferably comprised of a high strength metal and extends the full width of the structure panel **100**. Base channel **114** is generally U-shaped and is adapted to receive the bottom edge of the structural panel **100** in a tight-fitting manner. Connecting pins **154a** and **154c** securely attach the base channel **114** to the lower end of the structural panel **100**. A third connecting pin **154b** is inserted through the base channel **114** and into the foundation **116** for securely mounting the lower end of the structural panel **100** to the foundation. Attached to the upper end of the structural panel **100** is a top channel **118** also preferably comprised of metal. Connecting pins **152a** and **152b** are inserted through respective lateral portions of the top channel **118** and into the upper end of the structural panel **100** for securely attaching the top channel to the upper end of the panel. The top channel **118** also extends the full width of the structural panel **100** and is used to connect a roof panel **102** to the upper end of the structural panel **100** by means of a plurality of spaced connecting pins **120**. Each of the base and top channels **114,118** may also span one or more panels by being positioned on the lower or upper edges of several aligned panels. In this case, the base and top channels **114,118** may also be used to connect the adjacent panels by inserting connecting pins through the base and top channels and also through the lower and upper ends of each of the reinforcing members **108a,108b** disposed within each of the panels.

Roof panel **102** is also configured in accordance with the present invention as it includes first and second plastic impregnated paper outer facings **122a** and **122b** and first and second reinforcing members **124a** and **124b** (shown in dotted line form). Roof panel **102** also includes an insulating foam core **126** as well as a metal end cap **128**, preferably comprised of steel, attached by conventional means to an outer edge of the panel. Attached to the lower surface of the roof panel **102** by conventional means as previously described is interior drywall **136** as well as exterior soffit **138**. With the structural panel **100** forming an exterior wall of a building structure, the interior drywall **136** is disposed within the building and the soffit **138** is disposed outside of the building. Positioned on and attached to the upper surface of the roof panel **102** is roofing **134**, while attached to the outer edge of the roof panel is fascia **132**. The plastic impregnated paper outer facings **122a, 122b** provide the roof panel **102** with high tensile strength, while the first and second reinforcing members **124a,124b** provide the roof panel with high resistance to bending.

Roof panel **102** is connected to a second roof panel **104** to form a roof peak. Supporting the joined edge portions of the first and second roof panels **102,104** is the combination of a roof beam cap **144** and a roof beam **146**. First and second connecting pins **140** and **142** respectively inserted through the first and second roof panels **102,104** as well as through the roof beam cap **144** securely connect adjacent edges of the roof panels together as well as to the supporting roof beam **146**. As shown in the exploded view of FIG. 8, mastic strips **156a** and **156b** are disposed between the roof beam cap **144** and each of the first and second roof panels

102,104. Similarly, mastic strips **158a** and **158b** are disposed between abutting edges of the first and second roof panels **102,104** at the peak of the roof. These mastic strips further increase the strength of the roof at its peak.

Referring to FIG. 9, there is shown another embodiment of a structural insulated panel **160** in accordance with the principles of the present invention. Structural panel **160** includes an insulating foam core **162** and first and second opposed outer facings **164a** and **164b** which are comprised of a plastic impregnated paper as previously described. Disposed on the outer surfaces of each of the first and second outer facings **164a** and **164b** are a plurality of spaced reinforcing strips which are each comprised of wood in this embodiment. Thus, reinforcing strips **166a,168a** and **170a** are affixed to the outer surface of the first outer facing **164a** by means of an adhesive layer **172**. Similarly, wooden reinforcing strips **166b,168b** and **170b** are affixed to the outer surface of the second outer facing **164b** by means of a respective adhesive layer.

The structural insulated panel **160** shown in FIG. 9 also incorporates additional features relating to another embodiment of the invention. These additional features include first and second heat reflective layers **174a** and **174b** respectively disposed on and attached to the outer surfaces of the first and second outer facings **164a** and **164b**. These additional features further include a first drywall sheet **178a** attached to the outer reinforcing strips **166a,168a,170a** by conventional means such as an adhesive. Similarly, exterior siding **178b** is attached to reinforcing strips **166b,168b** and **170b**. A first space, or gap, **176a** is formed between the outer surface of the structural insulated panel **160** and the drywall sheet **178a**. Similarly, a second space **176b** is formed between the structural insulated panel **160** and the exterior siding **178b**. Each of the reflective layers **174a,174b** serves as a moisture barrier to prevent moisture from entering or passing through the panel and also reflects heat away from the structural insulated panel. Each of the spaces **176a** and **176b** formed between the structural insulated panel **160** and the drywall sheet **178a** and exterior siding **178b**, respectively, substantially increases the thermal insulating characteristics of the panel configuration shown in FIG. 9.

Referring to FIG. 10, there is shown a top plan view of another embodiment of a structural insulated panel **180** in accordance with the present invention. As in the previously described embodiments, structural panel **180** includes an inner insulating core **182** and first and second opposed outer facings **184a** and **184b** which are comprised of a plastic impregnated paper. A first plurality of reinforcing strips **186a, 188a** and **190a** are disposed within the insulating core **182** and are in contact with the inner surface of the panel's first outer facing **184a**. Each of the reinforcing strips has an adhesive coating **192** on its surface for bonding to the panel's insulating core **182** as well as to the inner surface of the first outer facing **184a**. A second plurality of reinforcing strips **186b,188b** and **190b** are disposed in the opposed surface of the insulating core **182** and are in contact with the inner surface of the panel's second outer facing **184b**. Each of the second plurality of reinforcing strips **186b, 188b** and **190b** is similarly provided with an adhesive coating for bonding to the panel's insulating core **182** as well as to the inner surface of the second outer facing **184b**. Bonding of the reinforcing strips to both the panel's insulating core **182** and the first and second outer facings **184a,184b** substantially increase the strength of the panel. As in the previously described embodiment, each of the reinforcing strips in structural panel **180** are preferably comprised of wood. Also in this embodiment of the invention, the first and second

outer facings **184a, 184b** of plastic impregnated paper are each provided with a respective reflective film **194a, 194b** on its surface. The reflective films **194a,194b** may be either metal-based such as of aluminum or may be comprised of a reflective plastic to provide a water vapor impervious barrier to prevent moisture from entering or passing through the structural panel **180**.

Referring to FIG. 11, there is shown a partial sectional view of the installation of a structural insulated panel **200** in accordance with another aspect of the present invention. As in the previously described embodiments, structural insulated panel **200** includes an insulating foam core **204** and first and second plastic impregnated paper outer facings **206a** and **206b** attached to respective opposed surfaces of the foam core. Attached to the first outer facing **206a** are a first plurality of spaced reinforcing members **208a**, where only one reinforcing member is shown in the figure. Similarly, attached to the second outer facing **206b** are a second plurality of spaced reinforcing members **208b**. An inner surface of the first plastic impregnated paper outer facing **206a** is attached to the panels' foam core **204** by means of a first inner adhesive layer **212**. Similarly, an outer surface of the first plastic impregnated outer facing **206a** is attached to the first reinforcing members **208a** by means of a second outer adhesive layer **214**. A similar connection arrangement is provided for the second outer facing **206b**.

In accordance with this aspect of the invention, top and bottom plates **210a** and **210b** are respectively attached to upper and lower edge portions of the structural insulated panel **200**. Each of the top and bottom plates **210a, 210b** is comprised of a 2X lumber structural member. The top and bottom plates **210a, 210b** may be attached to respective upper and lower edges of the structural insulated panel **200** by either an adhesive layer bonding the plates to the panels' foam core **204** and first and second outer facings **206a, 206b** or by connecting pins which are not shown in the figure as they have been previously described. The top plate **210a** facilitates attachment of the upper edge of the structural insulated panel **200** to a roof panel **218** by means of a top channel **216** and connecting pins such as nails or screws. Similarly, the bottom plate **210b** attached to the lower edge of the structural insulated panel **200** facilitates mounting the panel to a foundation or floor **202**.

Referring to FIG. 12, there is shown a partial sectional view of another installation arrangement for a structural insulated panel **220** in accordance with another aspect of the present invention. Structural panel **220** includes a plastic foam insulating core **224** and first and second pluralities of reinforcing members **226a** and **226b** attached to opposed surfaces of the foam core. Attached to outer portions of each of the first plurality of reinforcing members **226a** is a first plastic impregnated outer facing **228a**. Similarly, attached to respective outer portions of each of the plurality of second reinforcing members **208b** is a second plastic impregnated paper outer facing **206b**. Inner portions of each of the first plurality of reinforcing members **226a** are attached to the foam core **224** by means of an inner adhesive layer **232**, while respective outer portions of each of the first reinforcing members is attached to the first plastic impregnated paper outer facing **228a** by means of an outer adhesive layer **230**. A similar attachment arrangement is provided for between the second reinforcing members **226b** and the panels' foam core **224** and its second plastic impregnated paper outer facing **228b**.

In accordance with this aspect of the invention, top and bottom plates **234a** and **234b** are respectively inserted in upper and lower grooves in the structural insulated panel

220 and are arranged in abutting contact with respective upper and lower edges of the panels' foam core 224. Each of the top and bottom plates 234a, 234b is attached to the panels' foam core 224 as well as to its first and second reinforcing members 226a, 226b by means of respective adhesive layers applied to the top and bottom plates. The top plate 234a facilitates attachment of the structural insulated panel 220 to a roof panel 238 by means of a top channel 240. Similarly, the bottom plate 234b facilitates attachment of a lower edge of the structural insulated panel 220 to a foundation or floor 222 by means of a base plate 236. The top and bottom plates 234a, 234b as well as the base plate 236 are preferably comprised by 2X structural lumber members. Suitable connecting pins such as nails or screws are used to connect the top and bottom plates 234a, 234b to the top channel 240 and roof panel 238 as well as to the base plate 236 and foundation 222, although these connecting pins are omitted from the FIG. 4 simplicity.

There has thus been shown a structural insulated panel for building construction having a planar, rigid insulating core with opposed surfaces to which are bonded respective plastic impregnated paper (PIP) sheets forming outer facings on the panel. The insulating core is preferably comprised of a lightweight, plastic foam. Elongated, linear structural reinforcing members are incorporated in the panel in a spaced manner either on the outer surfaces of the PIP outer facings, or on the inner surfaces of the facings and thus within the panel's insulating core. The reinforcing members may be in the form of a flat strip or a U-shaped channel along its length and may be comprised of thin sheet metal or wood. Conventional metals such as steel or aluminum may be used in the structural members to provide the panel with high bending strength. The PIP outer facings provide the panel with high tensile strength and bonding the reinforcing members to the panel's outer facings and, in some cases, to the insulating core further increases the structural strength of the panel. The metal reinforcing members may also be provided with an outer gypsum coating to protect the metal strip from heat and/or fire. The panels may be used in walls, roofs, or floors and may be connected together along adjacent abutting lateral edges by means of a conventional adhesive or by top and bottom edge channels extending between the adjacent panels and connected to the upper and lower edges of the structural members in each of the panels. Metal caps may be positioned on lateral edges of the panels adjacent openings in the panels such as a doorway or window. The reinforcing members are arranged in a spaced manner along the width of the panel and are also preferably arranged symmetrically with respect to the plane of the panel.

While particular embodiments of the present invention have been shown and described, it will be obvious to those skilled in the art that changes and modifications may be made without departing from the invention in its broader aspects. Therefore, the aim in the appended claims is to cover all such changes and modifications as fall within the true spirit and scope of the invention. The matter set forth in the foregoing description and accompanying drawing is offered by way of illustration only and not as a limitation. The actual scope of the invention is intended to be defined in the following claims when viewed in their proper perspective based on the prior art.

I claim:

1. A reinforced, insulated flat structural panel comprising: a generally flat insulating core having first and second opposed sides; first and second planar sheets of plastic impregnated paper respectively disposed on the first and second sides of

said insulating core for providing the panel with high tensile strength;

first and second elongated, linear structural members respectively disposed in contact with said first and second sheets of plastic impregnated paper and extending substantially the entire length of the panel for increasing the bending strength of the panel and for attaching the panel to a support structure; and

an adhesive disposed on said first and second structural members for respectively bonding said first and second structural members to said first and second sheets of plastic impregnated paper, wherein said first and second structural members are respectively in contact with an inner surface of said first and second sheets of plastic impregnated paper and are disposed entirely within and displaced inwardly from an edge of the panel, and wherein said adhesive further bonds said first and second structural members to said insulating core.

2. The panel of claim 1 further comprising a first plurality of first structural members and a second plurality of second structural members each respectively in contact with and bonded to said first and second sheets of plastic impregnated paper and to said insulating core.

3. The panel of claim 1 wherein said first and second structural members are disposed in contact with and bonded to an outer surface of said first and second sheets of plastic impregnated paper, respectively.

4. The panel of claim 3 further comprising a first plurality of first structural members and a second plurality of second structural members arranged in a spaced manner and each respectively in contact with and bonded to a respective outer surface of said first and second sheets of plastic impregnated paper.

5. The panel of claim 1 wherein said first and second structural members are formed from sheet metal.

6. The panel of claim 5 wherein said sheet metal is comprised of steel or aluminum.

7. The panel of claim 1 wherein said first and second structural members are comprised of wood or gypsum composites.

8. The panel of claim 1 wherein each of said first and second structural members is in the form of a flat, thin strip.

9. The panel of claim 1 wherein each of said first and second structural members is in the form of a generally U-shaped channel, an angle, or includes a projecting portion along its length.

10. The panel of claim 1 wherein said adhesive is a urethane or epoxy cement, glue or a mastic coating.

11. The panel of claim 1 wherein said insulating core is comprised of plastic foam.

12. The panel of claim 11 wherein said plastic foam is expanded polystyrene, urethane or polyisocyanurate.

13. The panel of claim 1 wherein said insulating core is an agricultural product such as strawboard.

14. The panel of claim 1 wherein said first and second sheets of paper are impregnated with urethane or polyisocyanurate.

15. The panel of claim 1 further comprising upper and lower caps respectively disposed on top and bottom edges of the panel and extending substantially the entire width of the panel and attaching means for securely attaching said upper and lower caps to the upper and lower edges of said first and second structural members, respectively.

16. The panel of claim 15 wherein each of said upper and lower caps is comprised of sheet metal.

17. The panel of claim 16 wherein each of said upper and lower caps is generally U-shaped and includes a recessed portion adapted to receive an edge of the panel in a tight-fitting manner.

11

18. The panel of claim 17 wherein said attaching means includes threaded connecting pins or an adhesive material.

19. The panel of claim 18 wherein each of said upper and lower caps extend to and engage top and bottom edges of a second, adjacent panel for connecting the top and bottom panel edges of the panels.

20. The panel of claim 1 further comprising a channel disposed on a lateral edge of the panel for engaging a lateral edge of an adjacent channel, said panel further comprising connecting pins inserted through said channel for connecting the panels along their respective lateral edges.

21. The panel of claim 19 or 20 wherein a seam is formed between the panels, said panel further comprising an adhesive-backed tape strip attached to said panels and disposed over said seam.

22. The panel of claim 1 further comprising adhesive disposed on an edge of the panel for connecting the panel to a second adjacent panel.

23. The panel of claim 20 wherein a seam is formed between the panels, said panel further comprising an adhesive-backed tape strip attached to said panels and disposed over said seam.

24. The panel of claim 1 further comprising a reflective layer disposed on at least one of said sheets of plastic impregnated paper.

25. The panel of claim 24 wherein said reflective layer is metal- or plastic-based.

26. The panel of claim 25 wherein said metal is aluminum.

27. The panel of claim 1 further comprising one or more electrical chases disposed in said insulating core for receiving electrical wiring.

28. The panel of claim 1 further comprising a sheet of gypsum or cementous composite attached to an outer surface of said first sheet of plastic impregnated paper.

29. The panel of claim 28 further comprising a sheet of exterior siding attached to an outer surface of said second sheet of plastic impregnated paper.

30. The panel of claim 15 further comprising first and second coupling means for respectively connecting said

12

upper cap to a ceiling or roof member and said lower cap to a foundation or floor member.

31. The panel of claim 1 further comprising a layer of gypsum or cementous composite material disposed on said first and second structural members and under said adhesive means.

32. The structural panel of claim 1 further comprising first and second heat reflective layers respectively disposed on the outer surfaces of said first and second sheets of plastic impregnated paper.

33. The structural panel of claim 32 wherein said first and second structural members are attached to respective outer surfaces of said first and second sheets of plastic impregnated paper and are disposed over portions of said first and second heat reflective layers, respectively.

34. The structural panel of claim 33 further comprising a first flat panel attached to said first structural member so as to form a first insulating space between the structural panel and said first flat panel.

35. The structural panel of claim 34 further comprising a second flat panel attached to said second structural member so as to form a second insulating space between the structural panel and said second flat panel.

36. The structural panel of claim 35 wherein said first flat panel is a drywall sheet and said second flat panel is exterior siding.

37. The structural panel of claim 1 further comprising a top or a bottom plate respectively disposed over and in contact with upper or lower edges of said insulating core and between adjacent upper or lower edges of said first and second plastic impregnated papers sheets and structural members for attaching the panel to a support structure.

38. The structural panel of claim 37 wherein each of said top and bottom plates is comprised of 2x lumber.

39. The structural panel of claim 38 further comprising a base plate disposed on a lower edge of the structural panel and connected to said bottom plate for facilitating mounting the structural panel to a floor or foundation.

* * * * *