



US006402662B1

(12) **United States Patent**
Rieber

(10) **Patent No.:** **US 6,402,662 B1**
(45) **Date of Patent:** ***Jun. 11, 2002**

(54) **TRAMPOLINE SAFETY PAD ASSEMBLY**

(75) Inventor: **Frederick M. Rieber**, Alum Bank, PA (US)

(73) Assignee: **Hedstrom Corporation**, Bedford, PA (US)

(*) Notice: Subject to any disclaimer, the term of this patent is extended or adjusted under 35 U.S.C. 154(b) by 8 days.

This patent is subject to a terminal disclaimer.

(21) Appl. No.: **09/791,071**

(22) Filed: **Feb. 22, 2001**

(51) **Int. Cl.**⁷ **A63B 5/11; A63B 5/00**

(52) **U.S. Cl.** **482/27**

(58) **Field of Search** 482/51, 27, 28, 482/29, 35; 182/139, 140

(56) **References Cited**

U.S. PATENT DOCUMENTS

4,331,329 A 5/1982 Mirkovich et al.

4,431,182 A 2/1984 Reynolds
4,900,011 A 2/1990 Nolet
5,299,989 A 4/1994 Boyd et al.
5,385,518 A 1/1995 Turner
6,017,292 A 1/2000 Gift et al.
6,193,632 B1 2/2001 Steger

Primary Examiner—Stephen R. Crow

(74) *Attorney, Agent, or Firm*—Cesari and McKenna, LLP

(57) **ABSTRACT**

A trampoline pad assembly for securement to a trampoline of the type including a rebound surface suspended by springs from an elevated ring includes an annular top wall and an annular bottom wall secured together at congruent inner and outer edges to form an annular enclosure defining an interior pocket. At least one radial opening is formed in the bottom wall adjacent to the outer edge thereof which opening extends into the pocket. Resilient material is introduced into the pocket through the opening and an annular flexible skirt is secured to top wall adjacent to the outer edge thereof so that the skirt lies flat against the top wall. The skirt has a free edge and is foldable around those outer edges so that the skirt closes the opening thereby protectively enclosing the resilient material within the pocket and secures the pad assembly to the ring.

6 Claims, 3 Drawing Sheets

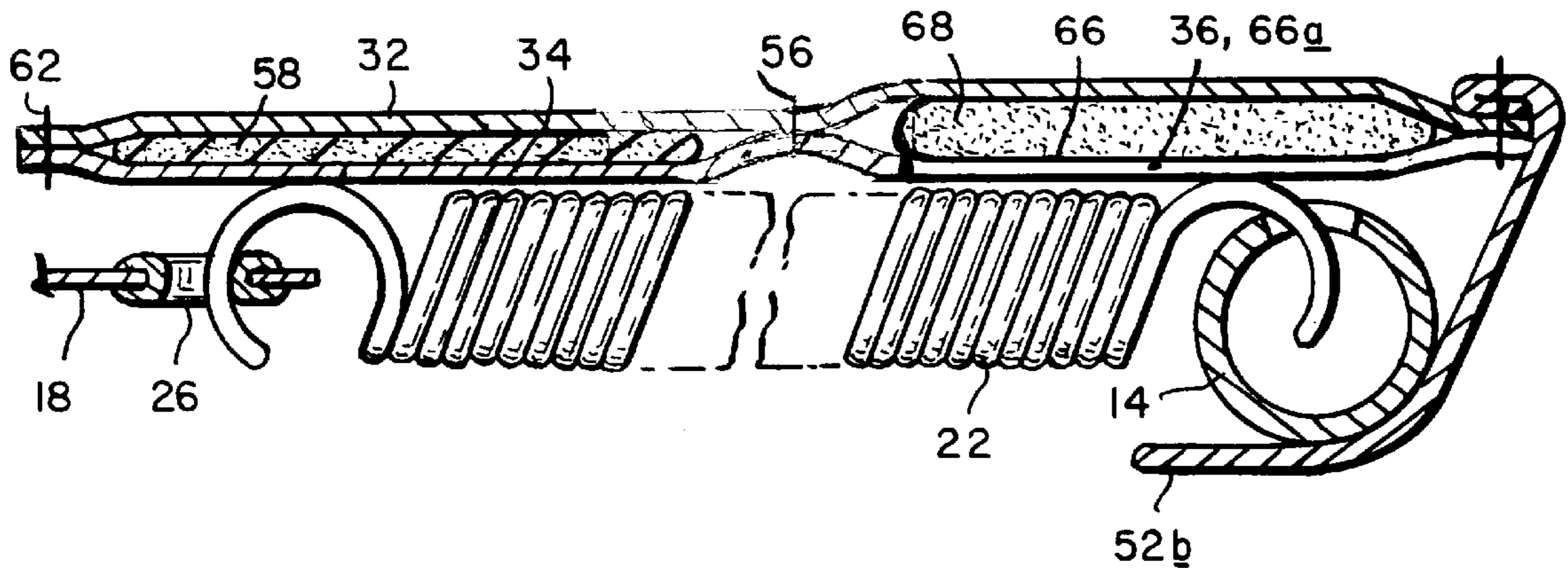

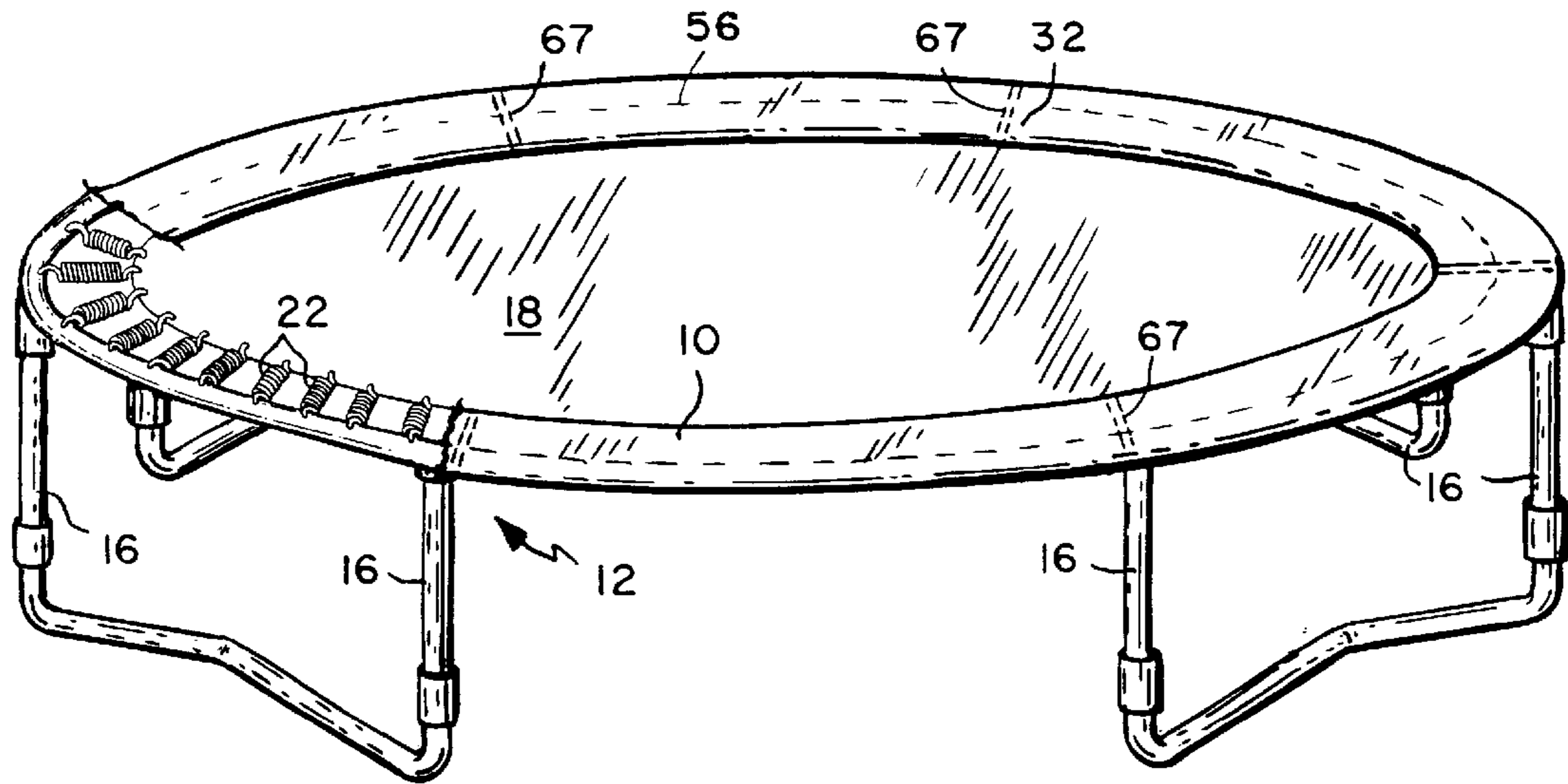

FIG. 1

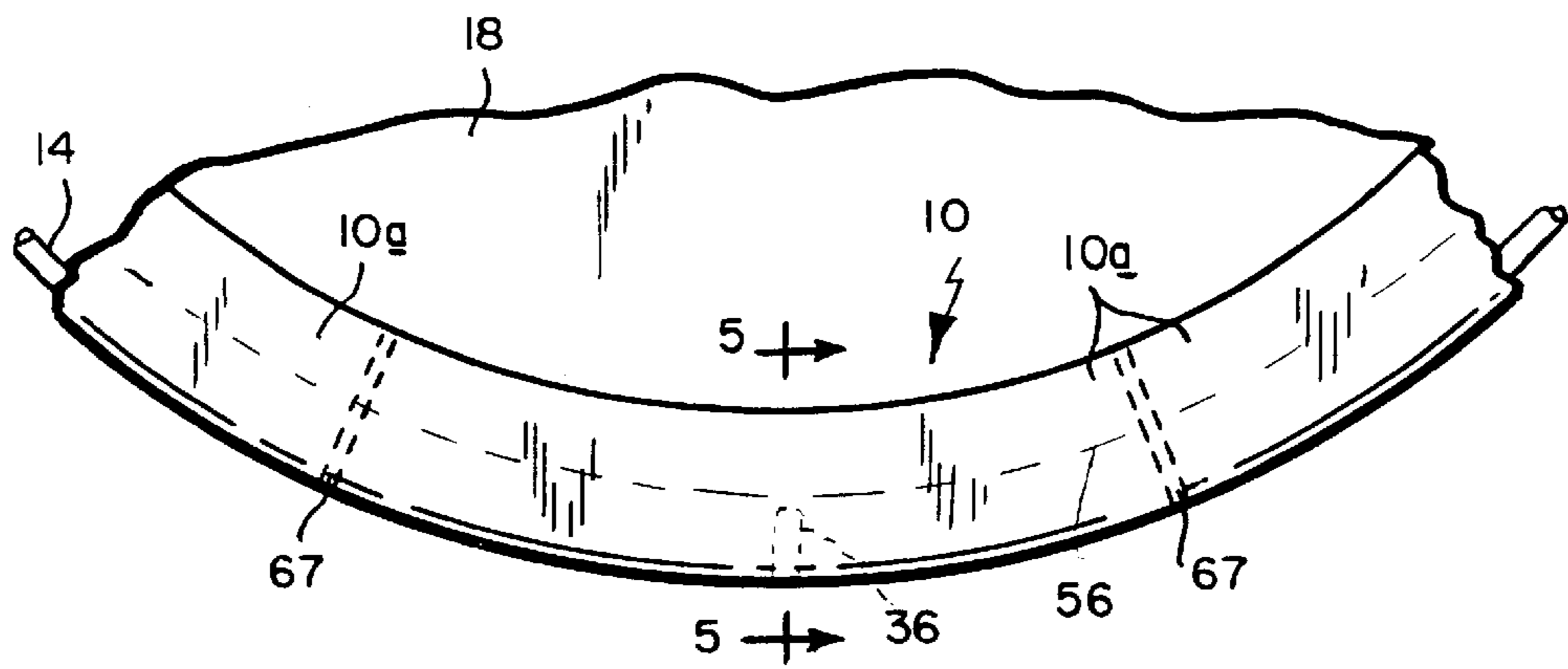

FIG. 2

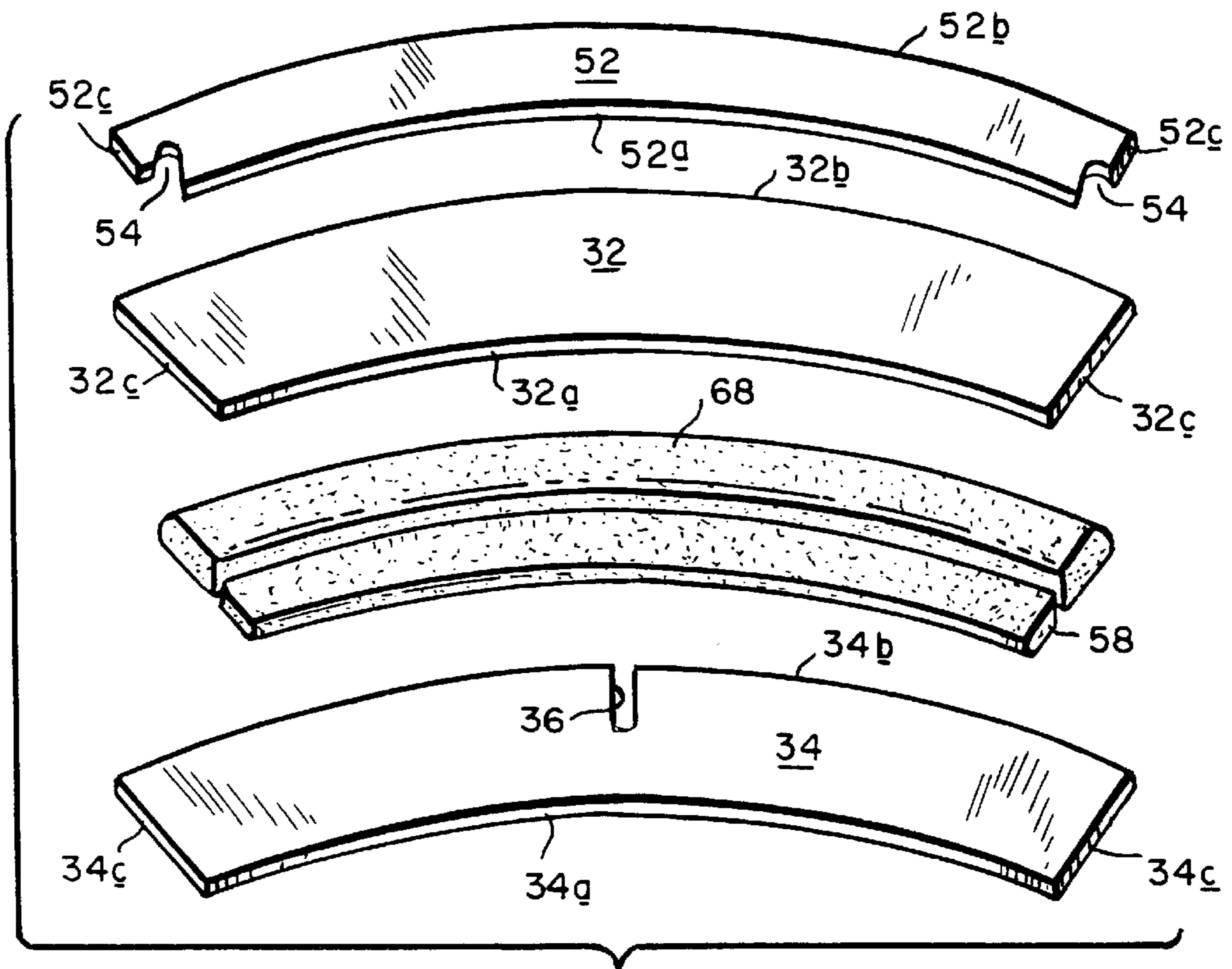

FIG. 3

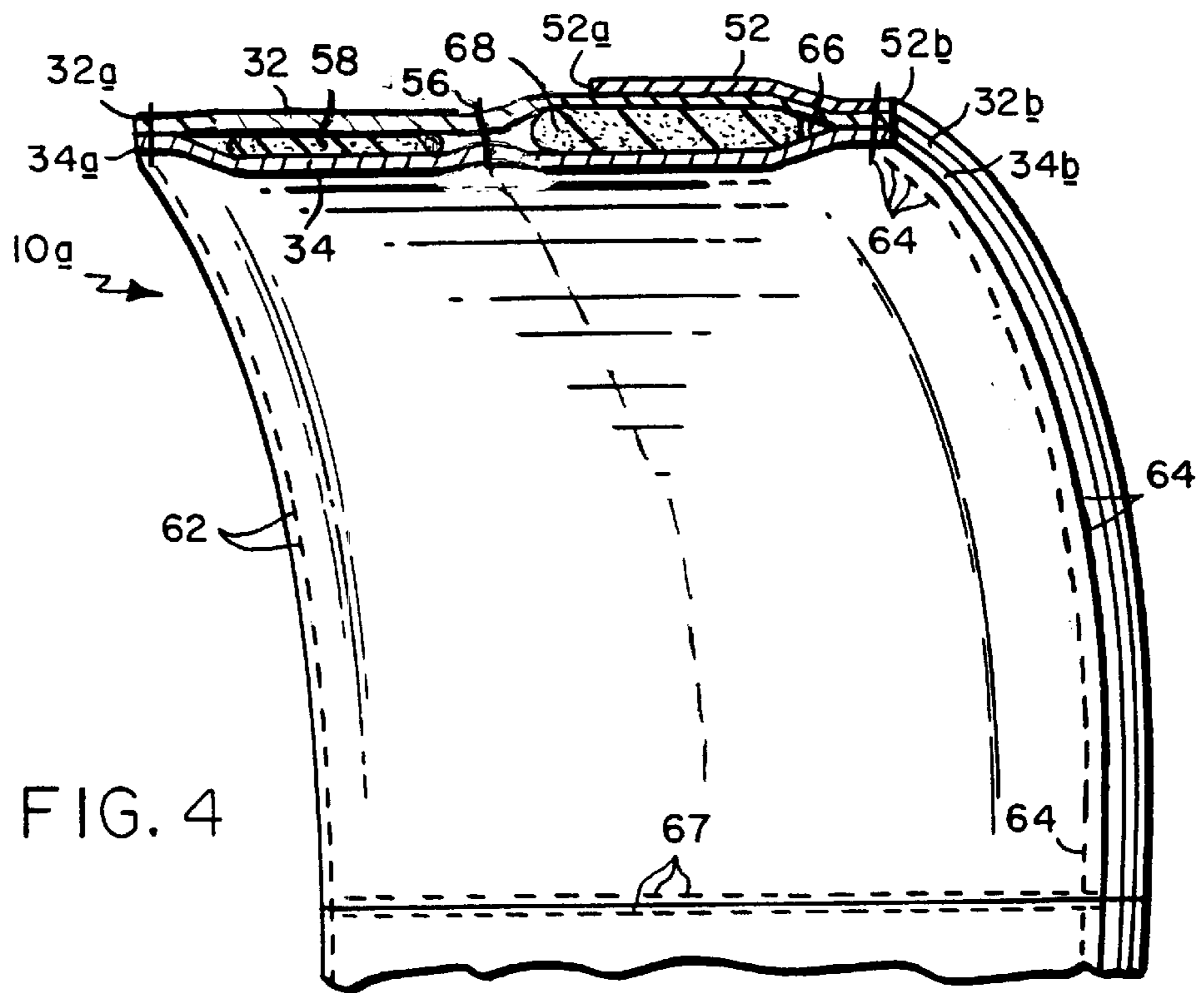

FIG. 4

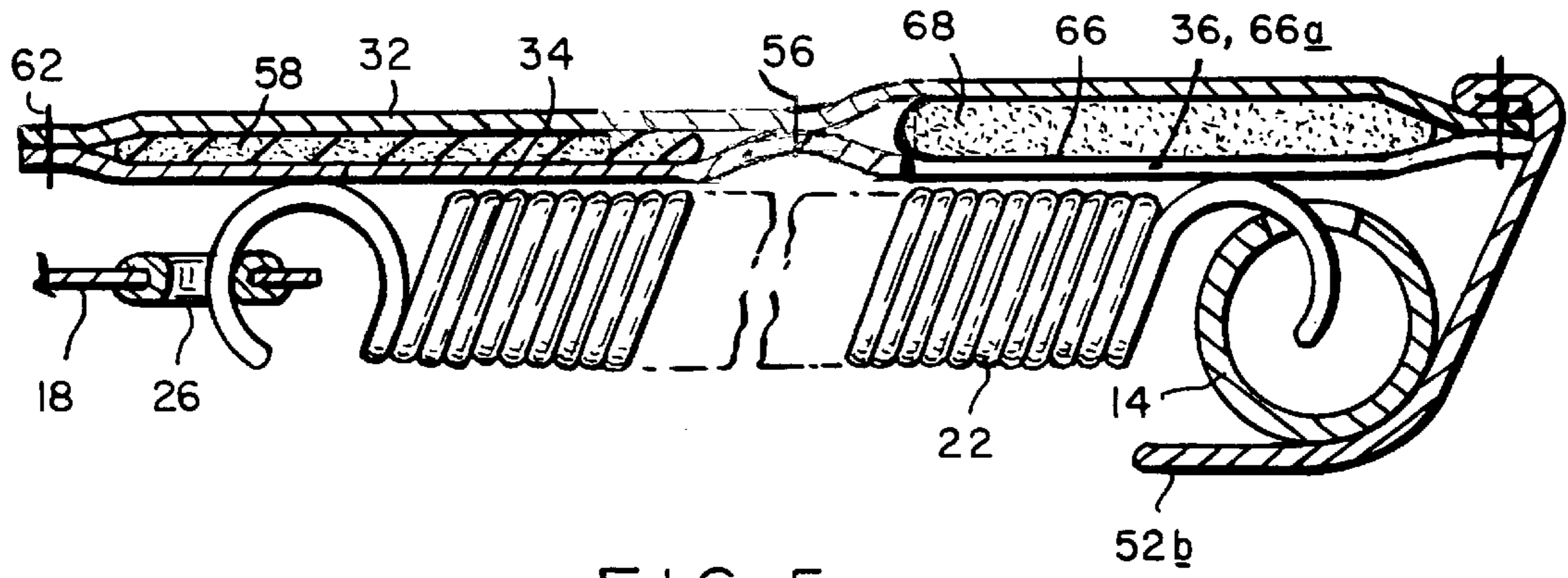

FIG. 5

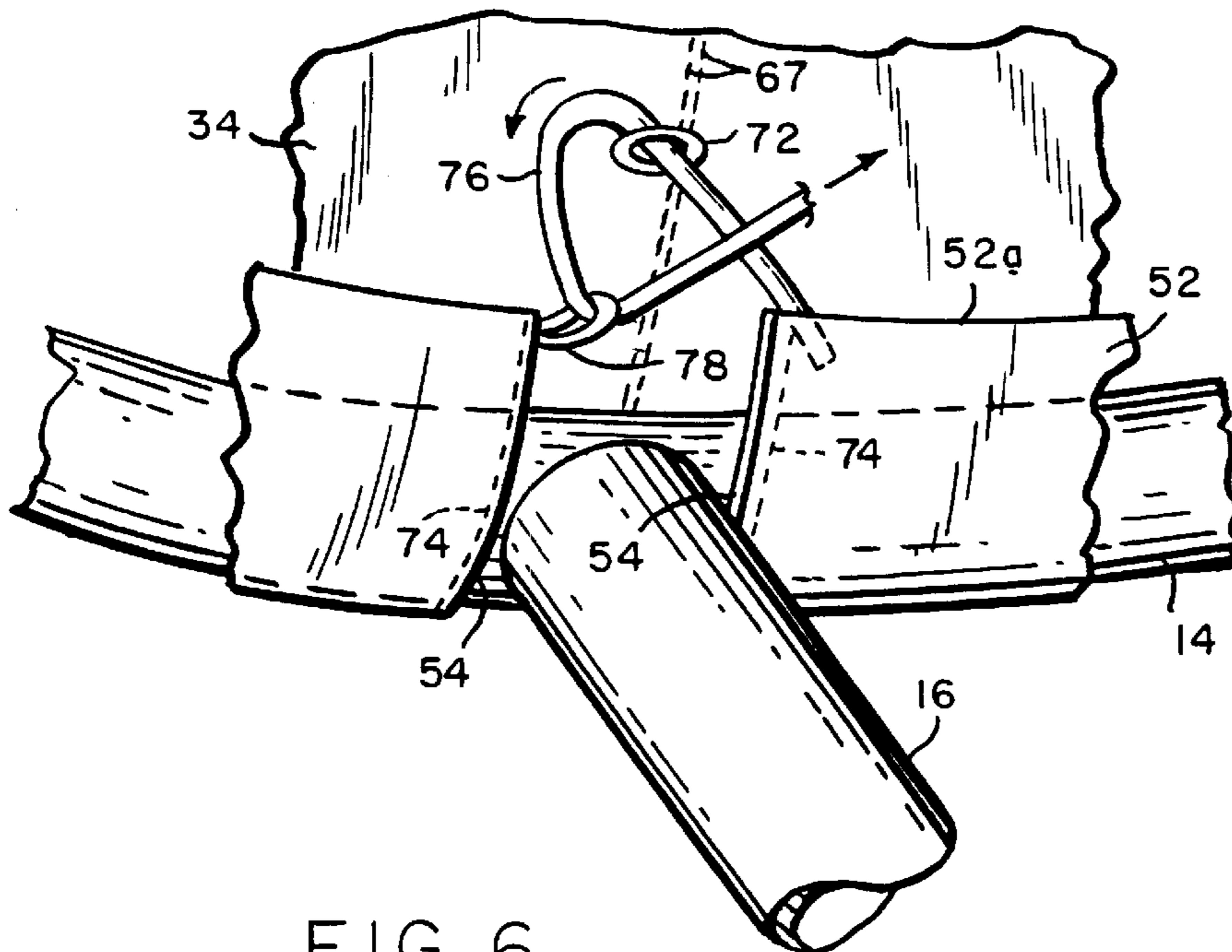

FIG. 6

TRAMPOLINE SAFETY PAD ASSEMBLY**BACKGROUND OF THE INVENTION**

Conventional trampolines are usually provided with an annular pad to cover the outer edge margin of the trampoline's rebound surface and the resilient connections of that surface to the ring which supports the rebound surface. Present day trampoline pad assemblies, which may or may not be filled with a resilient insert such as foam, usually include a gusset or skirt which is attached perpendicular to the plane of the pad surface. The circumference of the pad around the points of attachment to the trampoline frame is usually equal to the circumference of the bottom edge of the gusset. To install a pad on a trampoline, the pad is dropped down over the trampoline frame so that the gusset hangs downward around the perimeter of the ring which supports the trampoline's rebound surface. Sometimes, a draw cord is installed at the bottom edge of the gusset to reduce the circumference of that edge to a degree that prevents the cover from being lifted up from the trampoline frame.

Alternatively, the trampoline pads may incorporate straps or ties which are used to attach the pad directly to various parts of the trampoline frame.

We are also aware of a foam-filled pad whose pad skirt or gusset is engaged around the frame and attached by ties to the underside of the pad. That pad is disclosed in application Ser. No. 09/337,244 now U.S. Pat. No. 6,193,632 owned by the assignee of the present application.

While that pad has definite advantages, the assembly of the pad is somewhat difficult for the customer because of the relatively large foam inserts that have to be fitted into pockets in the pad. That is, the customer has to fold up each insert in order to fit the insert through the entrance of its pocket which entrance is located at the outer edge of the pad adjacent to the gusset. Once inserted into the pocket, the insert has to be manipulated until it lays flat within the pocket. Since a typical trampoline pad may have eight or more insert-containing pockets, the pad assembly process can be time consuming for the customer.

Another disadvantage of that prior pad is that locating the pocket entrances at the outer edge of the pad requires special cutting and stitching operations in order to connect the gusset to the upper and lower walls of the pad in such a way as to form the pocket entrances.

Accordingly, it would be desirable to be able to offer a trampoline pad which has the advantages of the pad described in the above application, yet which is easier to make and to assemble.

SUMMARY OF THE INVENTION

Accordingly, it is an object of the present invention to provide an improved pad for a trampoline.

Another object of the invention is to provide a trampoline pad assembly which includes thin foam inserts which can be installed at the factory and thicker replaceable foam inserts which can be installed easily by the customer.

A further object of the invention is to provide a trampoline pad assembly incorporating foam inserts which may be packed compactly for shipping and storage purposes.

Yet another object of the invention is to provide a trampoline pad assembly which, when installed on a trampoline, cannot be lifted up from the trampoline frame and thus automatically secures the replaceable foam inserts within their pockets.

A further object of the invention is to provide a trampoline pad which can be manufactured and assembled relatively easily at relatively low cost.

Other objects will, in part, be obvious and will, in part, appear hereinafter.

The invention accordingly comprises the features of construction, combination of elements and arrangement of parts which will be exemplified in the following detailed description, and the scope of the invention will be indicated in the claims.

Briefly, my trampoline pad assembly, when properly dimensioned, can be installed on more or less any conventional trampoline having an elevated, flexible rebound surface resiliently connected to a rigid frame surrounding the rebound surface. The pad is positioned on the trampoline so that it covers the edge margin of the rebound surface and its connections to the frame. The pad includes an annular, flexible cover composed of upper and lower walls which are secured together at their inner and outer edges to form an annular enclosure for containing a resilient filler material such as foam. Superimposed on, and parallel to, the cover top wall is an annular skirt whose outer edge margin is secured to the cover top wall at the same time the top wall is secured to the cover bottom wall. Also, at least one radial opening is provided in the cover bottom wall so that filler material can be inserted through that opening into the cover interior after the cover has been assembled.

Preferably the pad assembly is composed of a plurality of arcuate pad segments secured together end to end to form a ring or annulus. Each segment defines a pocket for containing a foam insert which can be inserted into the pocket through an annular opening in the bottom wall of that segment.

After the cover has been filled with filler material, the pad may be installed on a trampoline by centering the pad on the trampoline and folding the skirt down around the ring on the trampoline frame. While the outer edge of the skirt is large enough to fit over the frame ring, the inner edge is not with a result that when the skirt is folded down over the frame ring, its free edge margin does not hang downward but rather extends inward under tension toward the center of the trampoline. The skirt thus not only prevents the pad assembly from inadvertently lifting from the trampoline, it also closes the openings into the pockets containing the filler material.

To positively secure the pad in place, ties are provided at the ends of the skirt segments. By lacing the ties through loops secured to the cover bottom wall, the lower or inner edge of the skirt may be secured to the bottom wall so that the trampoline ring is positively captured by the skirt.

As we shall see presently, the trampoline pad assembly is composed of relatively few parts which can be made and assembled quite easily. Therefore, the pad assembly should not add appreciably to the overall cost of the trampoline.

BRIEF DESCRIPTION OF THE DRAWINGS

For a fuller understanding of the nature and objects of the invention, reference should be made to the following detailed description taken in connection with the accompanying drawings, in which:

FIG. 1 is a perspective view with parts broken away showing the trampoline pad assembly installed on a conventional trampoline;

FIG. 2 is a fragmentary top plan view on a larger scale showing in greater detail the trampoline pad assembly illustrated in FIG. 1;

FIG. 3 is an exploded perspective view on a still larger scale showing the components of the FIG. 2 pad assembly;

FIG. 4 is a fragmentary perspective view further illustrating the pad components and their assembly;

FIG. 5 is a sectional view taken along line 5—5 of FIG. 2 on a still larger scale showing the pad assembly installed on a trampoline, and

FIG. 6 is a fragmentary perspective view illustrating the securement of the pad to the trampoline frame.

DETAILED DESCRIPTION OF AN ILLUSTRATIVE EMBODIMENT

Refer to FIG. 1 of the drawings which shows a trampoline pad assembly incorporating the invention shown generally at 10 installed on a more or less conventional trampoline indicated generally at 12. Trampoline 12 comprises a rigid frame consisting of a ring 14 supported at an elevated position above the floor or ground by a plurality of legs 16 extending down from the ring. Centered within the ring is a flexible rebound surface 18 whose edge margin is secured to the ring by an array of coil springs 22. As shown in FIG. 5, one end of each spring 22 is hooked through a hole 24 in the ring while the opposite end of that spring is hooked through a grommet or eye 26 present adjacent the edge of rebound surface 18. When a person jumps up and down on the rebound surface, the springs flex making that surface highly resilient.

Referring now to FIGS. 1 and 2, the pad 10 is an annular assembly that covers the ring 14, springs 22 and the spring connections to the rebound surface 18. While a pad assembly could be a single round structure, it is preferably composed of a plurality of identical arcuate segments 10a secured together end to end. For a typical trampoline whose ring 14 has a diameter of 13 feet, pad 10 may be composed of eight pad segments 10a, each segment being about 5 feet long from end to end.

As best seen in FIGS. 3 and 4, each pad segment 10a comprises a flexible, arcuate upper wall 32 of a suitable flexible, weather-resistant sheet material such as vinyl plastic. Wall 32 has a radially inner edge 32a, a radially outer edge 32b and a pair of end edges 32c. The pad assembly also includes a more or less arcuate lower wall 34 having a radially inner edge 34a, an outer edge 34b and end edges 34c. The bottom wall 34 differs from top wall 32 in that it is formed midway along its length with an elongated radial slot or notch 36 extending from its outer edge 34b about half way toward inner edge 34a.

The third component of the pad assembly 10a is an arcuate skirt 52 having a radially inner edge 52a, and outer edge 52b and a pair of end edges 52c. The length of skirt 52 is more or less the same as that of top wall 32 but its radial extent is only about half that of top wall 32 so that it corresponds more or less to the radially outer edge margin of top wall 32. Furthermore, as best seen in FIG. 3, a pair of notches 54 may be formed in the end edges of skirt 52 adjacent the radially inner edge 52a thereof for reasons that will be described later.

As shown in FIG. 4, each pad segment 10a is assembled by placing top wall 32 on bottom wall 34 so that the two walls are more or less congruent and then situating skirt 52 on top wall 32 so that the outer end margins of the skirt and top wall are in register. Next, the two walls 32, 34 are stitched together midway along their widths by lengthwise stitching 56. Then, after inserting at the factory a thin, e.g. 1/8 in. or less, arcuate or annular foam strip(s) 58 between walls 32 and 34 radially inboard stitching 56, the radially inner edges 32a and 34a of the top and bottom walls are secured together by stitching 62, heat welds or other suitable

means. Also, the radially outer edges 32b, 34b of those walls, along with the radially outer edge 52b of skirt 52, are secured together by similar means such as stitching 64. As is evident from FIGS. 4 and 5, this stitching together of the top and bottom walls forms a pocket or enclosure 66 between the wall portions radially outboard stitching 56. Moreover, because of the presence of the slot 36 in bottom wall 34, the stitching 64 at the radially outer edge of each pad segment 10a does not capture bottom wall 34 at the mouth of the slot leaving a radial opening 66a into the pocket 66 between the two walls of the pad segment 10a.

During the same stitching operation, the ends of adjacent segments 10a are secured together by radial stitching 67. Because of the notches 54 in the ends of skirt 52, only the portions of the skirt ends radially outboard the notches are secured to the pad cover walls 32 and 34. When all segments 10a are stitched end to end, they form an annulus with all of the skirts 52 together constituting a segmented annular flap.

In accordance with the invention, each pocket 66 in the pad assembly is arranged and adapted to contain resilient material such as one or more arcuate foam inserts 68 shown in FIGS. 3 to 5, two being shown there. Inserts 68 are slightly narrower and shorter combined than pocket 66 so that they can be slid into opposite halves of pocket 66 via opening 66a without folding the inserts, i.e. they may be inserted in a flat condition. Preferably, inserts 68 are thicker, e.g. 1/2 in. or more, than the strip(s) 58 because they will overlie springs 22.

While many conventional trampoline pad assembly assemblies require all of the filler material to be incorporated into the pad during the cover stitching operation, pad assembly 10 has a definite advantage in the thin strip(s) 58 may be installed at the factory and being thin, they will not prevent the pad from being folded compactly for shipment. On the other hand, the thicker inserts 68 can be installed into the pad segments 10a after the factory stitching operation at a remote location, e.g. by the customer who purchases pad assembly 10. During shipment of the trampoline, those inserts will pack flat.

The easiest way to install the inserts 68 is to place the stitched-together walls or cover of the pad assembly on a flat surface so that the pad bottom wall 34 faces upwards exposing the pockets openings 66a. Then, two inserts 68 may be inserted endwise through the opening 66a into each half of the pocket 66 of each pad assembly segment 10a.

Once all of the pockets 66 have been filled with inserts 68, the pad assembly is in condition to be installed on trampoline 12 as shown in FIG. 1. For this, the pad assembly is centered on the trampoline 10 with its lower wall 34 facing downward and with the skirts 52 of all of the pad segments 10a lying flat against and parallel to the assembly top walls 32 and parallel to the nominal plane of the trampoline rebound surface 18. The pad assembly should be oriented so that the connected-together ends of the pad segments 10a at stitching 67 are located opposite the legs 16 as shown in FIG. 1. It is important to appreciate that the outer circumferences of the stitched together edges of walls 32 and 34 and of skirts 52 is large enough so that those edges overlap the trampoline ring 14. However, the total circumference of the free edges of the combined skirts is much smaller; indeed, it is smaller than the circumference of the rebound surface 18. Thus, it is too small to fit over the trampoline ring 14 except for the fact that the skirts 52 are not secured together end-to-end radially outboard from the notches 54 as described above.

As we shall see, the end notches 54 in the skirts 52 of adjacent segments 10a are mirror images of one another and

5

together form relatively large openings to provide clearance for the trampoline legs.

Once pad **10** is properly centered on trampoline **12**, the skirts **52** of the pad assembly segments **10a** are flipped or folded downward over the trampoline ring **14** as shown in FIG. **5**. Since the diameter of the free edges **52a** of the combined skirts is smaller than that of the ring, the combined skirts do not just drape down from the ring. Rather, they extend under tension radially inward under the ring toward the center of the trampoline as shown in that figure. Thus, they tend to retain the pad assembly **10** on trampoline **12**. They also overlap or cover all of the openings **66a** in the pad assembly segments **10a** thereby capturing the pad inserts **68** between walls **32** and **34**.

In order to assure such retention even in the presence of high winds and vigorous activity on the trampoline, provision is made for positively securing the pad assembly **10** to the trampoline. This is done in such a way that the securement of the pad to the trampoline does not create undue stresses on the pad assembly.

More particularly, and referring to FIGS. **5** and **6**, when connecting together the ends of adjacent pad segments **10a** by stitching **67**, a loop **72** is stitched to the exposed surface of bottom wall **34**. Also, during that stitching operation, the edges of the skirt notches **54** are hemmed by stitching **74**. During that process there is secured to the free radially inner end corner at one end of skirt **52** a tie string **76** and to a similar free corner at the opposite end of the skirt, a loop **78**. Thus, when the pad assembly **10** is properly positioned on trampoline **12**, a loop **72** is present radially inboard each trampoline leg **16** and a tie string **76** and loop **78** of adjacent pad assembly segments **10a** are located on opposite sides of a trampoline leg **16**, all is shown in FIG. **6**.

To secure the pad to the trampoline, each tie string **76** is passed through the adjacent loop **72** at the underside of wall **34** and then passed through the adjacent loop **78** and tied back on itself. Tying the ends of each segment **10a** of the pad assembly completes the closure of a circular skirt perimeter that is much smaller than the ring **14**. Also, lacing all of the tie strings **76** as aforesaid draws the pad assembly **10** centerline down close to the plane of the rebound surface **18**. This is desirable because the thickest part of the pad rests on top of the trampoline springs **22**. Accordingly, there is a tendency for the center of the pad to be lifted up above the rebound surface. Also, of course, the lacing of the tie strings **76** enhances the security of attachment of the pad assembly **10** to trampoline **12**.

It will be appreciated from the foregoing that the trampoline pad assembly described above has definite advantages over existing pads of this general type in that it permits installation of the thicker foam inserts **68** into the otherwise finished pad already containing the thinner foam strip(s) **58**. This can be done by unskilled personnel at the factory after the stitching operations on the pad assembly have been completed. Of course, those inserts can also be installed by the person who purchases the pad allowing the pad to be shipped and stored in a smaller space than the space required by a pad assembled completely at the factory. This construction also allows the inserts **68** to be easily removed and replaced if need be. When the pad assembly is installed on a trampoline, it remains centered in place and is relatively unaffected by high winds and activity on the trampoline. Yet,

6

the pad assembly is relatively easy to make and does not cost appreciably more than existing pads of this type which do not have the above advantages.

It will thus be seen that the objects set forth above, among those made apparent from the preceding description, are efficiently attained. Also, certain changes may be made in the above construction without departing from the scope of the invention. For example, the foam inserts **68** may be substituted for by padding or other filler material such as foam pieces. Therefore, it is intended that all matter contained in the above description or shown in the accompanying drawings shall be interpreted as illustrative and not in a limiting sense.

What is claimed is:

1. A trampoline pad assembly for securement to a trampoline of the type including a rebound surface suspended by springs from an elevated ring, said assembly comprising
 - an annular top wall and an annular bottom wall secured together at congruent inner and outer edges to form an annular enclosure defining an interior annular pocket; means defining at least one radial opening in said bottom wall, said opening extending into the pocket;
 - resilient material introduced into the pocket through said at least one opening;
 - an annular flexible skirt secured to said top wall adjacent to the outer edge thereof so that the skirt lies flat against said top wall, said skirt having a free edge and which is foldable around said outer edges to a closing position the skirt closes said at least one opening thereby protectively enclosing said resilient material within said pocket, and
 - means for maintaining said skirt in said closing position.
2. The pad assembly defined in claim 1 wherein said at least one opening extends radially inward from the outer edge of said bottom wall.
3. The pad assembly defined in claim 1 wherein said pocket extends from the outer edges of said walls partway along the radial extent of said walls to a line securing said walls that divides said pocket into radially inner and outer pocket sections.
4. The pad assembly defined in claim 1 wherein the top and bottom walls are of plastic sheet material and the resilient material is plastic foam.
5. The pad assembly defined in claim 4 wherein
 - the top and bottom walls and the skirt are composed of arcuate segments secured together end-to-end so that said pocket is composed of separate arcuate pocket segments;
 - a said opening is present in each bottom wall segment, and
 - said resilient material comprises one or more arcuate inserts inserted into each of said pocket segments through said opening therein.
6. The pad assembly defined in claim 4
 - wherein said inserts are located in said radially outer pocket section, and,
 - further including additional foam material in said radially inner pocket section, said additional foam material being thinner than said inserts.