



US006379619B1

(12) **United States Patent**  
**Rozga et al.**

(10) **Patent No.:** **US 6,379,619 B1**  
(45) **Date of Patent:** **Apr. 30, 2002**

(54) **ARTIFICIAL GUT**

(75) Inventors: **Jacek Rozga**, Westlake Village;  
**Achilles A. Demetriou**, Bel Air, both of  
CA (US)

(73) Assignee: **Cedars-Sinai Medical Center**, Los  
Angeles, CA (US)

(\* ) Notice: Subject to any disclaimer, the term of this  
patent is extended or adjusted under 35  
U.S.C. 154(b) by 0 days.

5,015,585 A	5/1991	Robinson	
5,043,260 A	8/1991	Jaurequi	
5,055,198 A	10/1991	Shettigar	
5,116,494 A	5/1992	Chick et al.	
5,152,743 A	10/1992	Gorsuch	
5,263,982 A	11/1993	Shimomura et al.	
5,270,192 A	12/1993	Li et al.	
5,368,555 A	11/1994	Sussman et al.	
5,387,237 A	2/1995	Fournier et al.	
5,525,305 A	6/1996	Minekus et al.	
5,698,161 A	* 12/1997	Montoya	422/48
5,827,729 A	* 10/1998	Naughton et al.	

\* cited by examiner

(21) Appl. No.: **09/294,737**

(22) Filed: **Apr. 19, 1999**

**Related U.S. Application Data**

(62) Division of application No. 08/856,522, filed on May 14,  
1997, now Pat. No. 5,993,406.

(51) **Int. Cl.**<sup>7</sup> ..... **A61M 1/14**; **A61M 1/34**;  
**A61M 37/00**

(52) **U.S. Cl.** ..... **422/48**; **604/4.01**; **604/6.09**

(58) **Field of Search** ..... **604/4.01**, **93.01**,  
**604/173**; **623/11-12**; **435/283-85**, **325**,  
**363**, **366**, **371**, **284.1**, **2**, **297.1**, **297.2**, **297.4**;  
**422/44**, **48**; **210/322**, **332**, **323.1**, **348**

(56) **References Cited**

**U.S. PATENT DOCUMENTS**

4,241,187 A	12/1980	White	
4,376,095 A	* 3/1983	Hasegawa	
4,627,836 A	* 12/1986	MacGregor	604/93
4,643,715 A	2/1987	Isono et al.	
5,011,472 A	4/1991	Aebischer et al.	

*Primary Examiner*—Angela D. Sykes  
*Assistant Examiner*—Patricia Bianco  
(74) *Attorney, Agent, or Firm*—Sidley Austin Brown &  
Wood

(57) **ABSTRACT**

An artificial gut (100) comprises a first hollow fiber (203) having an inner surface (215) that is lined with at least a portion of a layer of one or more of a plurality of biological components (205) that typically line a mammalian gut. Further, a second hollow fiber (201) is adjacent the first hollow fiber. The layer of one or more of the plurality of biological components can consist essentially of enterocytes. The enterocyte-lined inner surface is perfused with a feeding solution containing nutrients, and the enterocytes absorb, process, and transport the nutrients across the wall of the first hollow fiber. The nutrients eventually diffuse into the second hollow fiber. A perfusate selected from the group consisting of culture medium, blood, and plasma, can perfuse an inner surface of the second hollow fiber, whereby the perfusate is nourished by the nutrients.

**18 Claims, 1 Drawing Sheet**

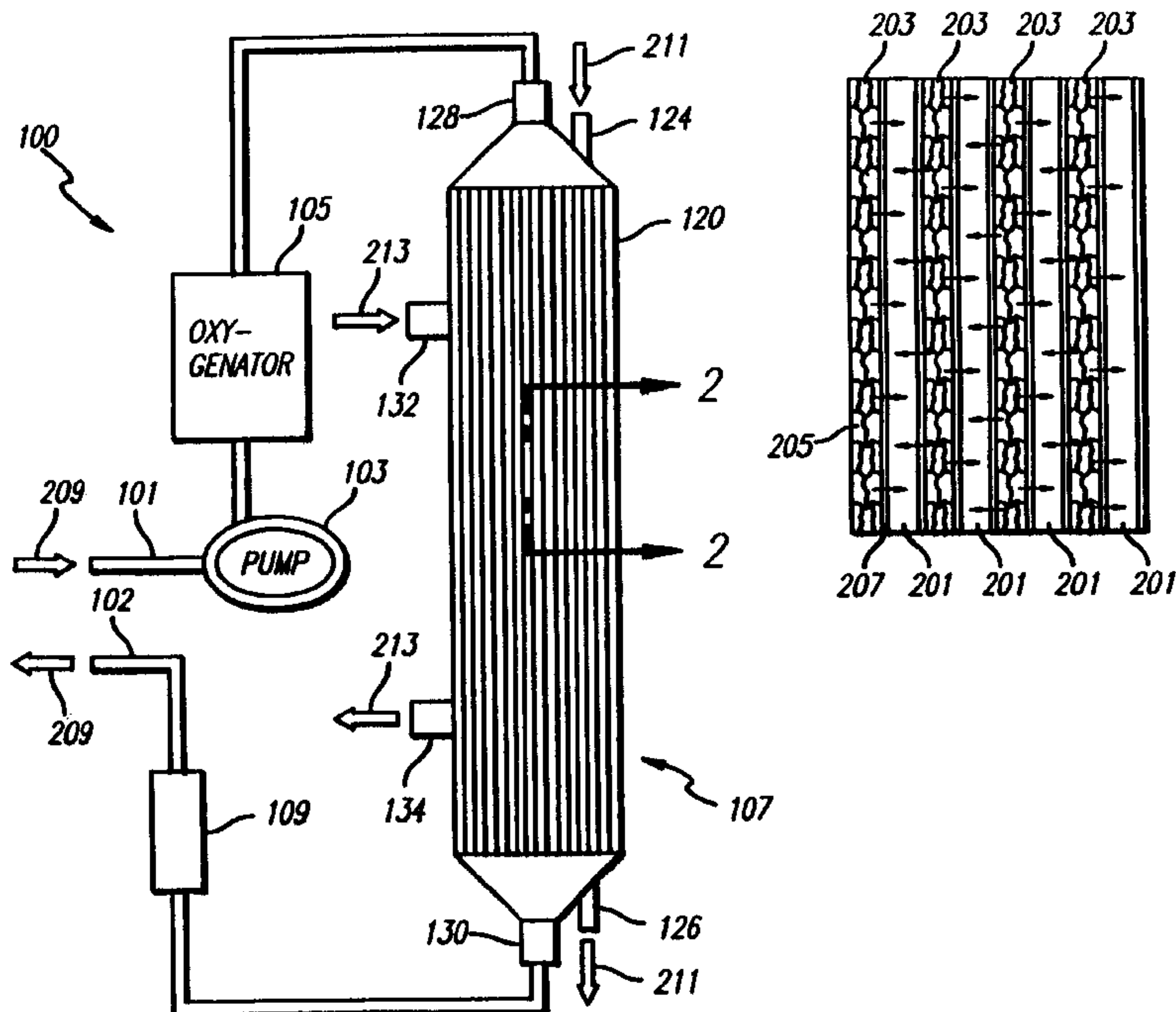

FIG. 1

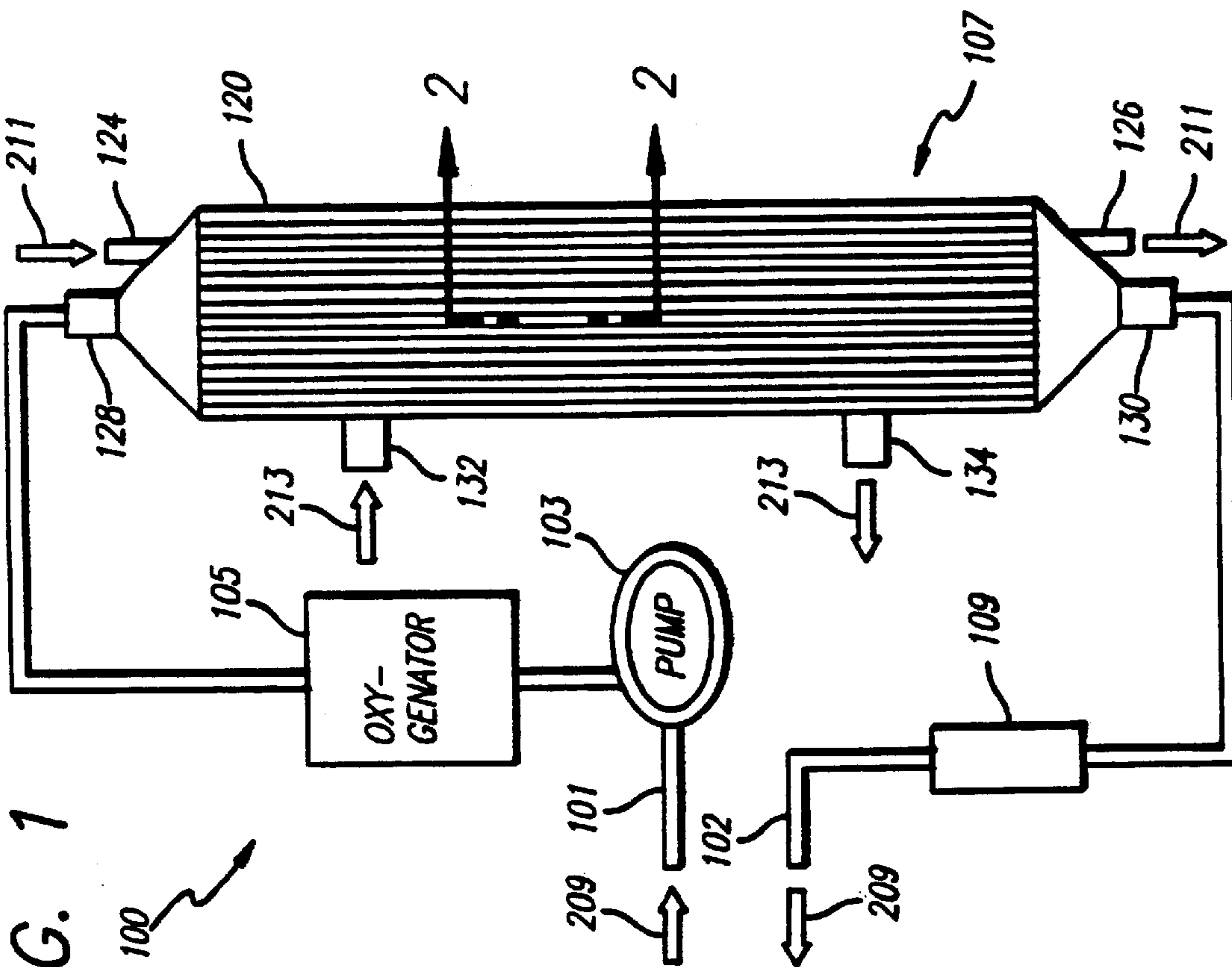

FIG. 2

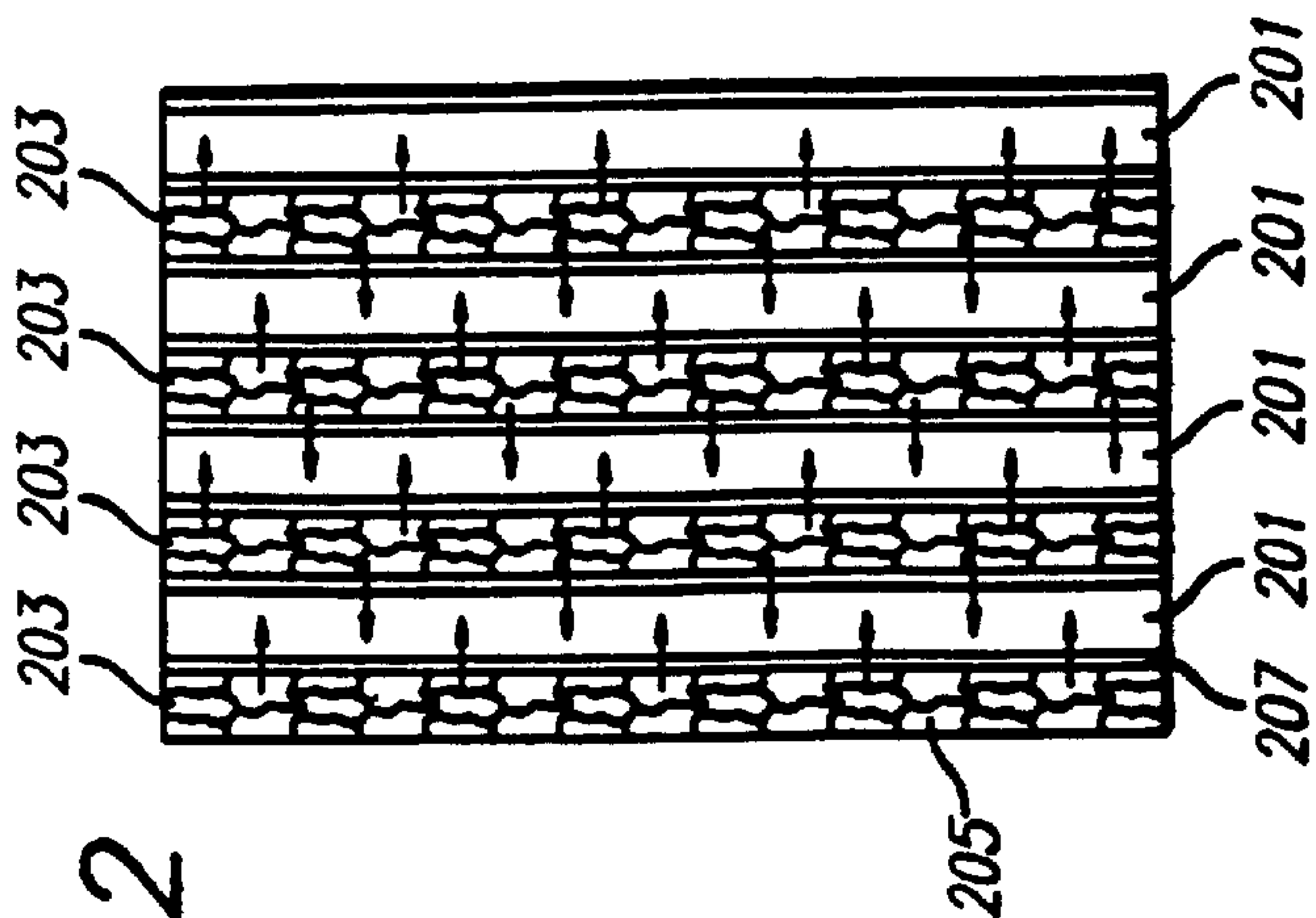
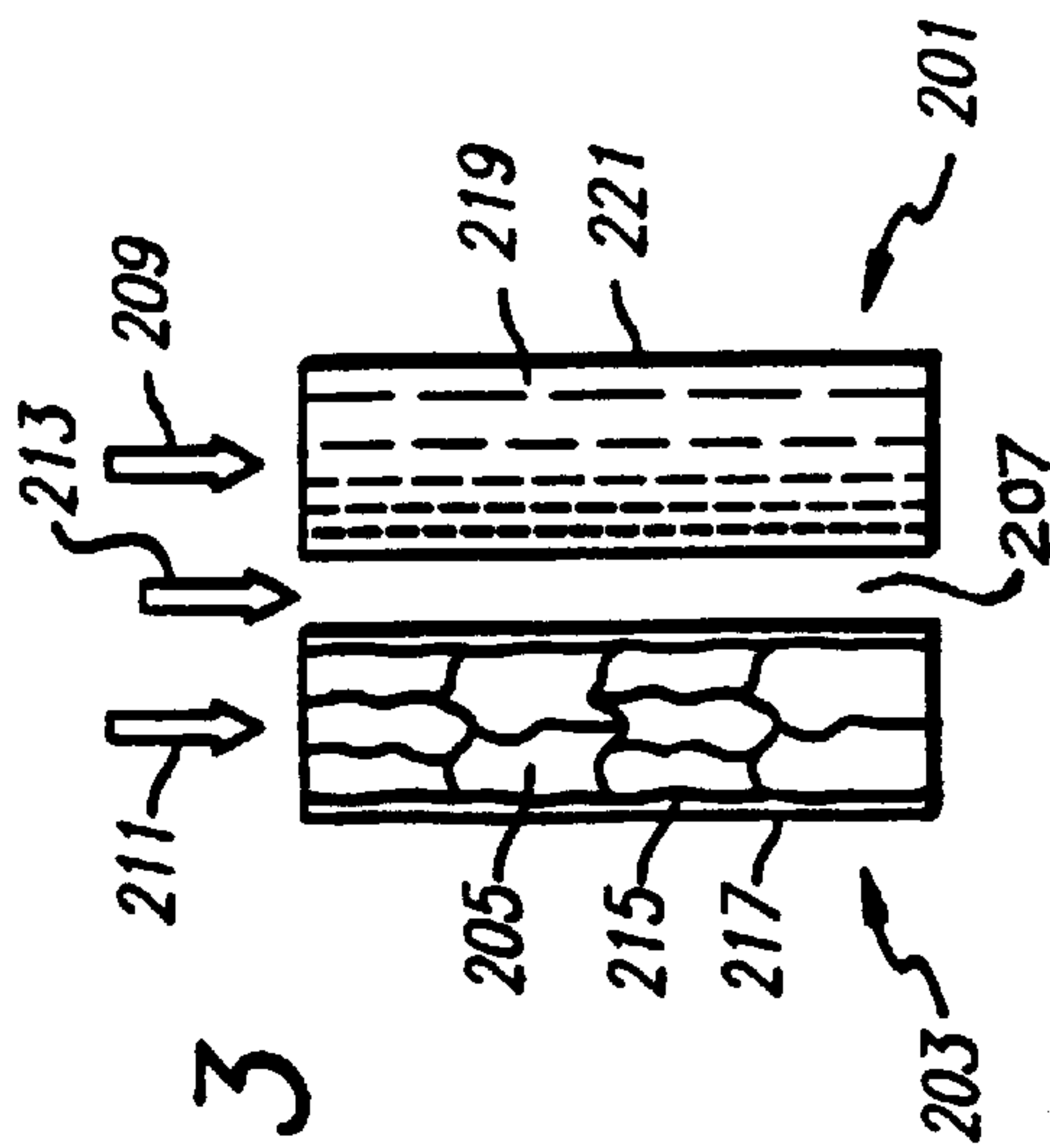

FIG. 3





## ARTIFICIAL GUT

The present application is a divisional of U.S. patent application Ser. No. 08/856,522, filed May 14, 1997 now U.S. Pat. No. 5,993,406, and the entire disclosure of such prior application is hereby incorporated herein by reference.

## FIELD OF THE INVENTION

The present invention relates generally to the field of artificial organs, and more particularly to an artificial gut and method therefore.

## BACKGROUND OF THE INVENTION

In the medical environment, it is often desirable to have apparatus that mimic human organs. Such apparatus can be used, for example, to study the organ and its reaction to agents, to produce cells, tissues, or other materials, or to treat patients whose human organ is failing.

Artificial organs, such as, kidney, liver, lung, and pancreas, have been described in the art. Furthermore, a model of a digestive tract that simulates peristaltic movements that move the contents of the intestine onward has been described. There is not known, however, an artificial gut that adequately mimics the anatomy, morphology, and function of the mammalian small intestine, especially the absorption of nutrients from the contents of the intestine into the blood stream.

A need therefore exists for an artificial gut, and a method of manufacture and use therefore, that mimics the anatomy, morphology, and function of the mammalian small intestine.

## SUMMARY OF THE INVENTION

The artificial gut, and method of manufacture and use therefore, described herein provides advantages over a mechanical gut in that it tends to mimic the anatomy, morphology, and function of the mammalian small intestine.

According to the present invention, the foregoing advantages are principally provided by an artificial gut that comprises a first hollow fiber having an inner surface that is lined with at least a portion of a layer of one or more of a plurality of biological components that typically line a mammalian gut. Further, a second hollow fiber is adjacent to the first hollow fiber.

In accordance with another aspect of the invention, the layer of one or more of the plurality of biological components consists essentially of enterocytes. The enterocyte-lined inner surface is perfused with a feeding solution containing nutrients, and the enterocytes absorb, process, and transport the nutrients across the wall of the first hollow fiber. The nutrients eventually diffuse into the second hollow fiber. A perfusate selected from the group consisting of culture medium, blood, and plasma, can perfuse an inner surface of the second hollow fiber, whereby the perfusate is nourished by the nutrients.

In another aspect of the invention, there can be a first system of a plurality of hollow fibers and a second system of a plurality of hollow fibers contained in a housing. The housing and outer surfaces of the first system of hollow fibers and the second system of hollow fibers define an extra-fiber space. The housing includes a first set of perfusion ports coupled with the first system of hollow fibers, and a second set of perfusion ports coupled with the second system of hollow fibers.

According to another aspect of the invention, the enterocytes lining the first system of hollow fibers absorb the

nutrients and pass them into the extra-fiber space. The nutrients in the extra-fiber space then diffuse into the second system of hollow fibers.

In accordance with the method of manufacture of this invention, providing a first system of a plurality of hollow, porous fibers and a second system of a plurality of hollow, porous fibers, and lining the inner surface of each of the plurality of hollow, porous fibers of the first system with a layer of one or more of a plurality of biological components that line a mammalian gut.

In accordance with the method of using of this invention, providing an artificial gut including a first system of a plurality of hollow fibers and a second system of a plurality of hollow fibers, and lining the inner surface of each of the plurality of hollow fibers of the first system with a layer of one or more of the plurality of biological components. The lined inner surface of each of the plurality of hollow fibers of the first system is perfused with a first perfusate, and the inner surface of each of the plurality of hollow fibers of the second system is perfused with a second perfusate.

The method more particularly comprises the substeps of seeding the first system of a plurality of hollow fibers with the one or more of the plurality of biological components, and perfusing the outer surface of each of the plurality of hollow fibers of the first system with an oxygenated cell culture medium enriched with humoral components. The humoral components maintain viability and morphological integrity of the plurality of the biological components, and facilitate or enhance their function.

Additional advantages and novel features of the invention will be set forth in part in the description which follows, wherein only the preferred embodiments of the invention are shown and described, and in part become apparent to those skilled in the art upon examination of the following detailed description or may be learned by practice of the invention. The advantages of the invention may be realized and attained by means of the instrumentalities and combinations particularly pointed out in the appended claims.

## BRIEF DESCRIPTION OF THE DRAWINGS

FIG. 1 is an elevation view of an artificial gut.

FIG. 2 is an enlarged, partial sectional view of a bioreactor along plane 2'—2'.

FIG. 3 is a detailed, sectional view of a first hollow fiber and a second hollow fiber.

## DESCRIPTION OF THE PREFERRED EMBODIMENTS

Reference will now be made in detail to the embodiments configured according to the present invention.

FIG. 1 is an elevation view of an artificial gut **100** for mimicking a mammalian gut. Artificial gut **100** comprises a bioreactor **107** that includes a rigid plastic housing **120** containing a first system of hollow fibers and a second system of hollow fibers.

As shown in FIG. 2, which is an enlarged, partial sectional view of bioreactor **107** along plane 2'—2', the first system of hollow fibers includes a plurality of first hollow fibers **203**, and the second system of hollow fibers includes a plurality of second hollow fibers **201**. The plurality of first hollow fibers **203** the plurality of second hollow fibers **201** are adjacent and intertwined with each other.

FIG. 3 is a detailed, sectional view of first hollow fiber **203** and second hollow fiber **201**. First hollow fiber **203** has an inner surface **215** and an outer surface **217**. Likewise,



second hollow fiber **201** has an inner surface **219** and an outer surface **221**. Housing **120** and outer surfaces **221,217** of the plurality of first and second hollow fibers **201,203** define an extra-fiber space **207**.

The inner surfaces **215** define a first compartment that is separate from extra-fiber space **207**. Likewise, the inner surfaces **219** define a second compartment that also is separated from extra-fiber space, or third compartment, **207**. Additionally, the first compartment and the second compartment are separated from each other.

The mammalian gut is typically lined with a plurality of biological components, for example, enterocytes, crypt cells, basement membrane, and matrix components. A layer of one or more of the plurality of biological components **205** lines at least a portion of inner surface **215** of first hollow fiber **203**.

Referring back to FIG. 1, housing **120** further includes a first set of perfusion ports-inlet port **124** and outlet port **126**-coupled with the first system of hollow fibers. The first set of perfusion ports admit a first perfusate **211** through inlet port **124**, which perfuses the lined inner surfaces **215** of first hollow fibers **203**. First perfusate **211** exits outlet port **126**. First perfusate **211** is transparent in FIGS. 2 and 3.

Housing **120** further includes a second set of perfusion ports-inlet port **128** and outlet port **130**-coupled with the second system of hollow fibers. The second set of perfusion ports admit a second perfusate **209** through inlet port **128**, which perfuses the inner surfaces **219** of second hollow fibers **201**. Second perfusate **211** exits outlet port **130**.

Housing **120** further includes a third set of perfusion ports-inlet port **132** and outlet port **134**-coupled with extra-fiber space **207**. The third set of perfusion ports admit a third perfusate **213** through inlet port **132**, which perfuses at least the outer surfaces **217** of the first hollow fibers **203**. The third perfusate exits outlet port **134**.

Artificial gut **100** further comprises a pump **103** that circulates second perfusate **209** through the second system of hollow fibers via the second set of ports; an oxygenator **105**, coupled between the pump and the second system of hollow fibers, that enriches the second perfusate **209** with oxygen before it enters the second system of hollow fibers via inlet port **128**; and, finally, a microporous filter **109** that filters out the one or more biological components from second perfusate **209** after second perfusate **209** leaves the second system of hollow fibers via outlet port **130**. The filtering prevents leakage of the biological component into, for example, a patient's blood circulation when a patient is connected to lines **101,102**.

In the preferred embodiment, first perfusate **211** consists essentially of a feeding solution including nutrients. The feeding solution can be, for example, a liquid food formula or a test substance. Further, second perfusate **209** is selected from the group **20** consisting of culture medium, blood, and plasma. And, third perfusate **213** consists essentially of a warm (37° C.) oxygenated cell culture medium enriched with humoral components, for example, nutrients, hormones, or trophic/growth factors, which are normally present in the animal or human intestinal lumen or in the blood that nourishes the intestinal wall.

Also in the preferred embodiment, first hollow fibers **203** have large pores, and second hollow fibers **201** have pores

sized to a predetermined molecular weight cut-off at or below the level of the largest molecules absorbed in the mammalian gut during the normal process of digestion. Furthermore, inner surfaces **215** are lined with a confluent layer of one or more biological components **205**, for example, enterocytes.

The method of operation of artificial gut **100** constructed as described above will be now be described.

One or more of the plurality of biological components is harvested from the mammalian intestine or a biological component cell line, and the harvested one or more of the biological components is used to seed the first system of hollow fibers. The technique for harvesting and seeding the biological components is well known in the art.

The harvested biological components are then grown in bioreactor **107** by perfusing outer surfaces **217** of first hollow fibers **203** with third perfusate **213** via the third set of ports. The one or more biological components grow and eventually line inner surfaces **215** of first hollow fibers **203** with a layer of the seeded biological components.

Prior to normal operation of artificial gut **100** and during the process of seeding, growing, or maintaining the one or more of the biological components, outer surface **217** of first hollow fibers **203** is continuously perfused with third perfusate **213**. Perfusing with the third perfusate maintains the viability, integrity, and function of the one or more biological components lining inner surfaces **215** of first hollow fibers **203**.

Prior to normal operation, third perfusate **213** is vacated from extra-fiber space **207** via outlet port **134**.

In normal operation, lined inner surface **215** of first hollow fiber **203** is perfused with first perfusate **211**, and inner surface **219** of second hollow fiber **201** is perfused with second perfusate **209**. Extra-fiber space **207** is filled with a mixture of diffused products from first perfusate **211** and second perfusate **209** that migrate through first and second hollow fibers **203,201**.

In the preferred embodiment, enterocytes **205** absorb the nutrients from feeding solution **211**. The nutrients are then processed and passed into extra-fiber space **207** by enterocytes **205**; and, ultimately, the nutrients pass into second hollow fiber **201** where they are absorbed by either the culture medium, blood, or plasma **209**. The arrows shown in FIG. 2 indicate the transport of nutrients across the enterocyte layer into the lumen of fibers **201**.

Those skilled in the art will recognize that various modifications and variations can be made in the artificial gut of the present invention and in construction and operation of this artificial gut without departing from the scope or spirit of this invention. For example, one of ordinary skill in the art will appreciate that potential applications of the artificial gut include but are not limited to (a) study of the pathophysiology of the intestinal tract, (b) study of the absorption of nutrients and other agents, (c) testing of new enteral/parenteral nutrition formulas and studying their effect on artificial gut morphology and function, (d) an ex vivo system to feed human patients with short-gut syndrome, malabsorption of various etiology, and surgical patients requiring nutritional support, and (e) use of a device as an alternative to intravenous total parenteral nutrition.



What is claimed is:

**1.** An artificial gut for mimicking a mammalian gut, the artificial gut comprising:

a first hollow fiber having a first inner surface;

a layer of one or more of a plurality of biological components that are typical of biological components that line a mammalian gut, said layer lining at least a portion of the first inner surface of the first hollow fiber; and

a second hollow fiber adjacent the first hollow fiber, said second hollow fiber having a second inner surface, wherein the first and second hollow fibers are intertwined.

**2.** The artificial gut of claim **1**, further comprising a culture medium enriched with humoral components, wherein the first hollow fiber has an outer surface that is perfused with the culture medium.

**3.** The artificial gut of claim **1**, further comprising a feeding solution, wherein the layer of one or more of the plurality of biological components is perfused with the feeding solution.

**4.** The artificial gut of claim **1**, further comprising a perfusate selected from the group consisting of culture medium, blood, and plasma, and the second inner surface of the second hollow fiber is perfused with the perfusate.

**5.** The artificial gut of claim **1**, wherein the one or more of the plurality of biological components consists essentially of enterocytes.

**6.** The artificial gut of claim **1**, further comprising a housing for containing the first hollow fiber and the second hollow fiber, the first hollow fiber has an outer surface and the second hollow fiber has an outer surface, wherein the housing and outer surfaces of the first hollow fiber and the second hollow fiber define an extra-fiber space.

**7.** The artificial gut of claim **6**, further comprising:

the one or more of the plurality of biological components consisting essentially of enterocytes;

a feeding solution containing nutrients, wherein the enterocytes are perfused with the feeding solution; and

a perfusate selected from the group consisting of culture medium, blood, and plasma, and the second inner surface of the second hollow fiber is perfused with the perfusate,

whereby the enterocytes absorb the nutrients and pass them into the extra-fiber space, and the nutrients passed into the extra-fiber space are diffused into the second hollow fiber.

**8.** An artificial gut for mimicking a mammalian gut, the artificial gut comprising:

a first system of a plurality of hollow fibers, each hollow fiber of the first system has an inner surface and an outer surface;

a layer of one or more of a plurality of biological components that are typical of biological components that line a mammalian gut, said layer lining each inner surface of the hollow fibers of the first system of hollow fibers;

a second system of a plurality of hollow fibers, each hollow fiber of the second system has an inner surface and an outer surface; and

a housing for containing the first system of hollow-fibers and the second system of hollow fibers, wherein the housing and outer surfaces of the first system of hollow fibers and the second system of hollow fibers define an extra-fiber space, the housing includes,

a first set of perfusion ports, coupled with the first system of hollow fibers, for perfusing the lined inner surfaces of the plurality of hollow fibers of the first system with a first perfusate, and

a second set of perfusion ports, coupled with the second system of hollow fibers, for perfusing the inner surfaces of the plurality of hollow fibers of the second system with a second perfusate.

**9.** The artificial gut of claim **8** wherein the first system of a plurality of hollow fibers and the second system of a plurality of hollow fibers are intertwined.

**10.** The artificial gut of claim **8** wherein the first perfusate consists essentially of a feeding solution including nutrients.

**11.** The artificial gut of claim **10** wherein the one or more of the plurality of biological components consists essentially of enterocytes, wherein the enterocytes absorb, process, and pass the nutrients into the extra-fiber space.

**12.** The artificial gut of claim **11** wherein the plurality of hollow fibers of the second system have pores sized to a predetermined molecular weight cut-off at or below the level of the largest molecules absorbed in the mammalian gut during the normal process of digestion, and the nutrients passed into the extra-fiber space are diffused into the second system of a plurality of hollow fibers.

**13.** The artificial gut of claim **12** wherein the second perfusate is selected from the group consisting of culture medium, blood, and plasma.

**14.** The artificial gut of claim **8**, wherein the housing further includes a third set of perfusion ports, coupled with the extra-fiber space, for perfusing the outer surfaces of the plurality of hollow fibers of the first system with a third perfusate that consists essentially of a culture medium enriched with humoral components.

**15.** The artificial gut of claim **8** further comprising a pump for circulating the second perfusate through the second system of a plurality of hollow fibers via the second set of ports.

**16.** The artificial gut of claim **15** further comprising an oxygenator, coupled between the pump and the second system of a plurality of hollow fibers, for enriching the second perfusate with oxygen before it enters the second system of a plurality of hollow fibers.

**17.** The artificial gut of claim **8** further comprising a microporous filter for filtering the second perfusate after it exits the second system of a plurality of hollow fibers.

**18.** An artificial gut for mimicking a mammalian gut, the artificial gut comprising:

a first system of hollow, porous fibers, each hollow, porous fiber of the first system has an inner surface and an outer surface;

a confluent layer of enterocytes lining each inner surface of the hollow, porous fibers of the first system;

a second system of hollow, porous fibers intertwined with the first system of hollow, porous fibers, each hollow, porous fiber of the second system has an inner surface and an outer surface and pores sized to a predetermined molecular weight cut-off at or below the level of the largest molecules absorbed in the mammalian gut during the normal process of digestion;

a housing for containing the first system of hollow, porous fibers and the second system of hollow, porous fibers, wherein the housing and outer surfaces of the hollow, porous fibers of the first system and the hollow, porous fibers of the second system define an extra-fiber space, the housing includes,

a first set of perfusion ports, coupled with the first system of hollow, porous fibers, for perfusing the enterocyte-lined inner surfaces of the hollow, porous

7

fibers of the first system with feeding solution including nutrients,  
a second set of perfusion ports, coupled with the second system of hollow, porous fibers, for perfusing the inner surfaces of the plurality of hollow, porous fibers of the second system with culture medium, blood, or plasma, and  
a third set of perfusion ports, coupled with the extra-fiber space, for perfusing the outer surfaces of the hollow, porous fibers of the first system with a culture medium enriched with humoral components;  
a pump for circulating the culture medium, blood, or plasma through the second system of hollow, porous fibers;

8

an oxygenator for enriching the blood or plasma with oxygen before it enters the second system of hollow, porous fibers; and  
a microporous filter for filtering out enterocytes from the blood or plasma after the blood or plasma leaves the second system of hollow, porous fibers,  
wherein the enterocytes absorb the nutrients from the feeding solution, process the absorbed nutrients, and pass the processed nutrients into the extra-fiber space, and the nutrients in the extra-fiber space are diffused into the second system of hollow, porous fibers.

\* \* \* \* \*