



US006373965B1

(12) **United States Patent**
Liang

(10) **Patent No.:** **US 6,373,965 B1**
(45) **Date of Patent:** **Apr. 16, 2002**

(54) **APPARATUS AND METHODS FOR AUTHENTICATION USING PARTIALLY FLUORESCENT GRAPHIC IMAGES AND OCR CHARACTERS**

(75) Inventor: **Louis H. Liang**, Los Altos, CA (US)

(73) Assignee: **Angstrom Technologies, Inc.**, Erlanger, KY (US)

(*) Notice: Subject to any disclaimer, the term of this patent is extended or adjusted under 35 U.S.C. 154(b) by 0 days.

(21) Appl. No.: **09/428,348**

(22) Filed: **Oct. 27, 1999**

Related U.S. Application Data

(60) Continuation-in-part of application No. 09/241,555, filed on Feb. 1, 1999, which is a division of application No. 08/863,846, filed on May 27, 1997, now Pat. No. 5,867,586, which is a division of application No. 08/265,399, filed on Jun. 24, 1994, now Pat. No. 5,719,948.

(51) **Int. Cl.**⁷ **G06K 9/00**

(52) **U.S. Cl.** **382/112; 382/115; 382/181**

(58) **Field of Search** **382/112, 232, 382/115, 181, 187**

(56) **References Cited**

U.S. PATENT DOCUMENTS

3,573,472 A 4/1971 Madalo 380/23
4,131,879 A 12/1978 Ehrat 340/146.3

(List continued on next page.)

OTHER PUBLICATIONS

W. J. Fant et al., "Infrared Transparent Credit Card" IBM Technical Disclosure Bulletin, vol. 9 No. 7 (Dec. 1966) p. 870.

Primary Examiner—Jose L. Couso
Assistant Examiner—Anh Hong Do

(74) *Attorney, Agent, or Firm*—Theodore R. Touw

(57) **ABSTRACT**

An authentication system combines a source of ultraviolet light (and optionally a scanning mechanism) with apparatus for capturing and recognizing either graphic images or characters or both, where the graphic images and/or characters have been previously made with fluorescent substances that may be invisible under ordinary visible light, but are rendered detectable by the ultraviolet light. As in conventional optical character recognition (OCR), the characters may be conventional alphanumeric characters readable by human readers once they are made visible. The authentication system has a housing enclosing its optical path, a source of UV light, a detector for detecting graphic images or characters, conversion of the detector signal to digital form, a memory storing predetermined indicia, recognition logic, and indicating means. The system may also include a scanning mechanism and optical filters to select predetermined wavelengths of fluorescent light. The detector may be capable of detecting both fluorescent images and normal visible images, and the authentication system may incorporate switching mechanisms to allow multiplexed acquisition of fluorescent and normally visible images. The authentication system can operate in conjunction with a process for marking articles with indicia selected from a predetermined set of graphic images and characters readable by optical character recognition and/or by image comparison. That process can include printing fluorescent graphic images or characters in registration with (or with predetermined offset from) visible images or characters or indicia printed with substances fluorescent at different wavelengths. The recognition logic of the authentication system can include comparison of fluorescent and visible images or two different fluorescent images with each other. Pairs of indicia to be recognized and/or compared may be arranged to constitute a stereogram or other arrangement for first-order authentication by a human observer.

26 Claims, 9 Drawing Sheets

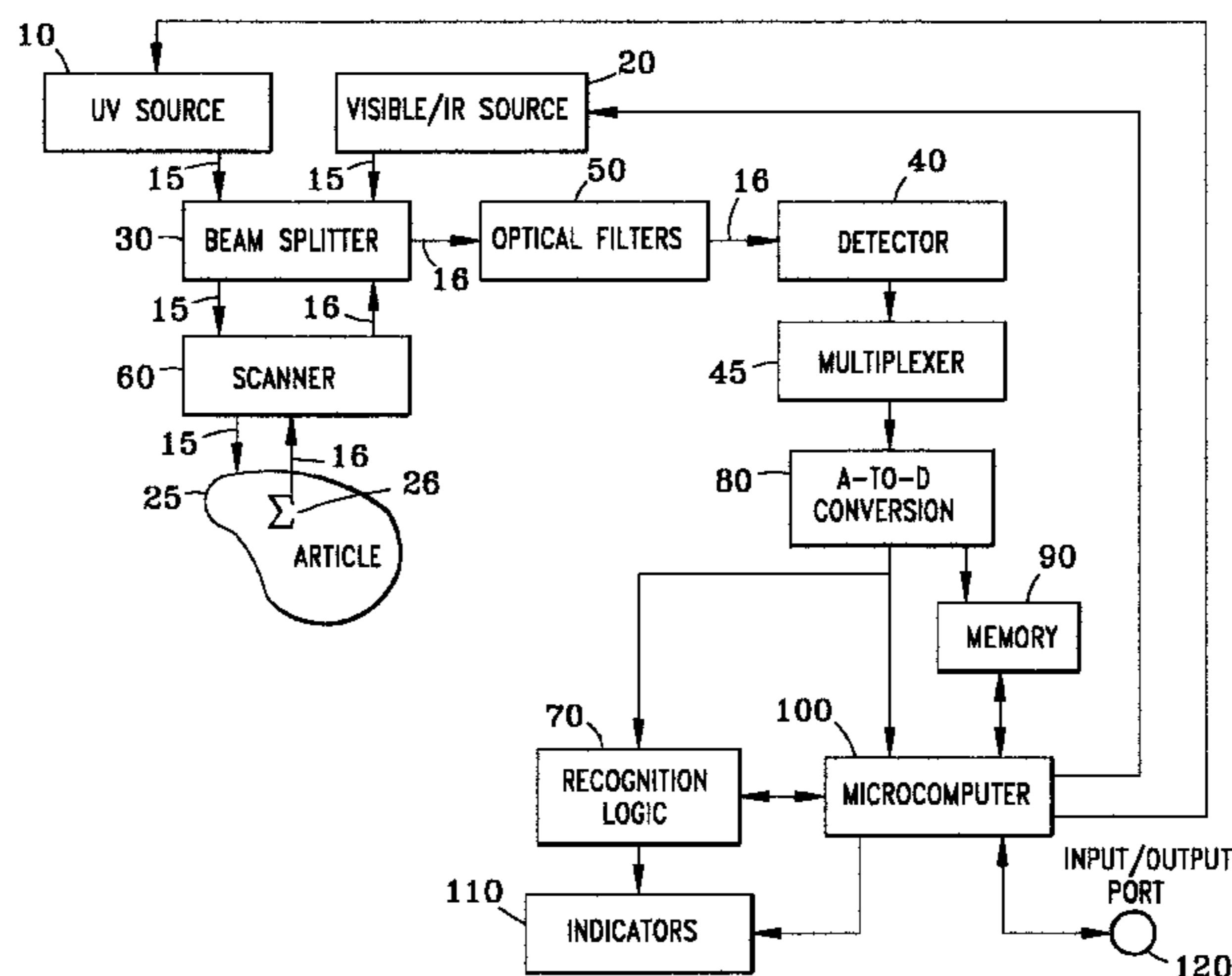

US 6,373,965 B1

Page 2

U.S. PATENT DOCUMENTS

4,146,792 A	3/1979	Stenzel et al.	250/365	5,719,948 A	2/1998	Liang	382/112
4,533,244 A	8/1985	Kaule et al.	356/71	5,745,604 A	4/1998	Rhoads	382/232
4,889,367 A	12/1989	Miller	283/88	5,748,763 A	5/1998	Rhoads	382/115
4,988,126 A	1/1991	Heckenkamp et al.	283/92	5,748,783 A	5/1998	Rhoads	382/232
5,160,171 A	11/1992	Gregory et al.	283/91	5,760,384 A	6/1998	Itoh et al.	235/468
5,418,855 A	5/1995	Liang et al.	380/23	5,764,770 A	6/1998	Schipper et al.	380/25
5,433,807 A	7/1995	Heckenkamp et al.	156/230	5,768,426 A	6/1998	Rhoads	382/232
5,514,860 A	5/1996	Berson	235/468	5,799,082 A	8/1998	Murphy et al.	380/7
5,544,045 A	8/1996	Garland et al.	364/419.03	5,809,160 A	9/1998	Powell et al.	382/100
5,548,106 A	8/1996	Liang et al.	235/454	5,822,436 A	10/1998	Rhoads	380/54
5,592,561 A	1/1997	Moore	382/103	5,832,119 A	11/1998	Rhoads	382/232
5,636,292 A	6/1997	Rhoads	382/232	5,841,886 A	11/1998	Rhoads	382/115
5,673,338 A	9/1997	Denenberg et al.	382/209	5,841,978 A	11/1998	Rhoads	395/200.47
5,710,834 A	1/1998	Rhoads	382/232	5,850,481 A	12/1998	Rhoads	382/232
5,714,291 A	2/1998	Marinello et al.	430/106	5,862,260 A	1/1999	Rhoads	382/232
5,719,939 A	2/1998	Tel	380/23	5,867,586 A	2/1999	Liang	382/112
				5,959,296 A	9/1999	Cyr et al.	250/271

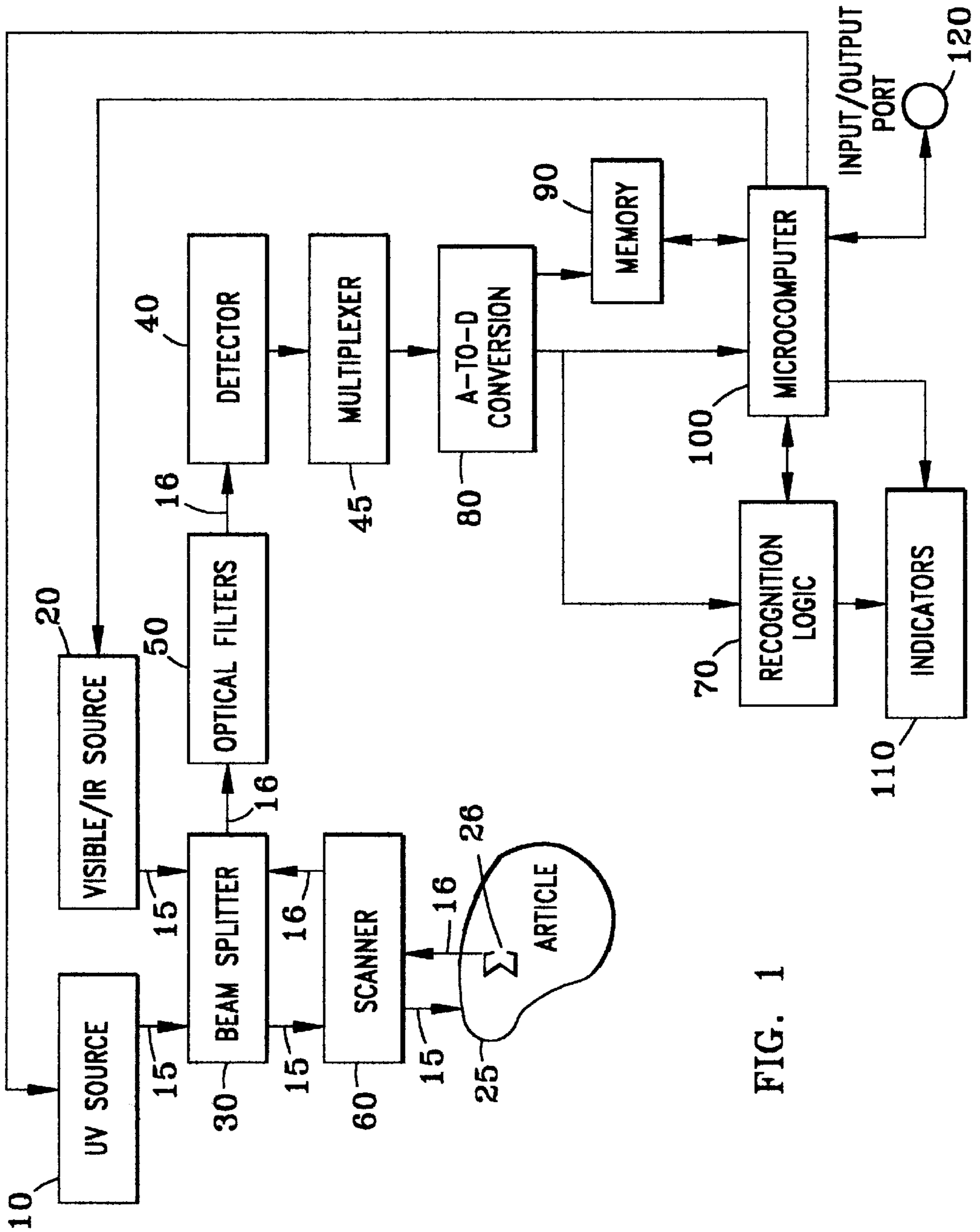

FIG. 1

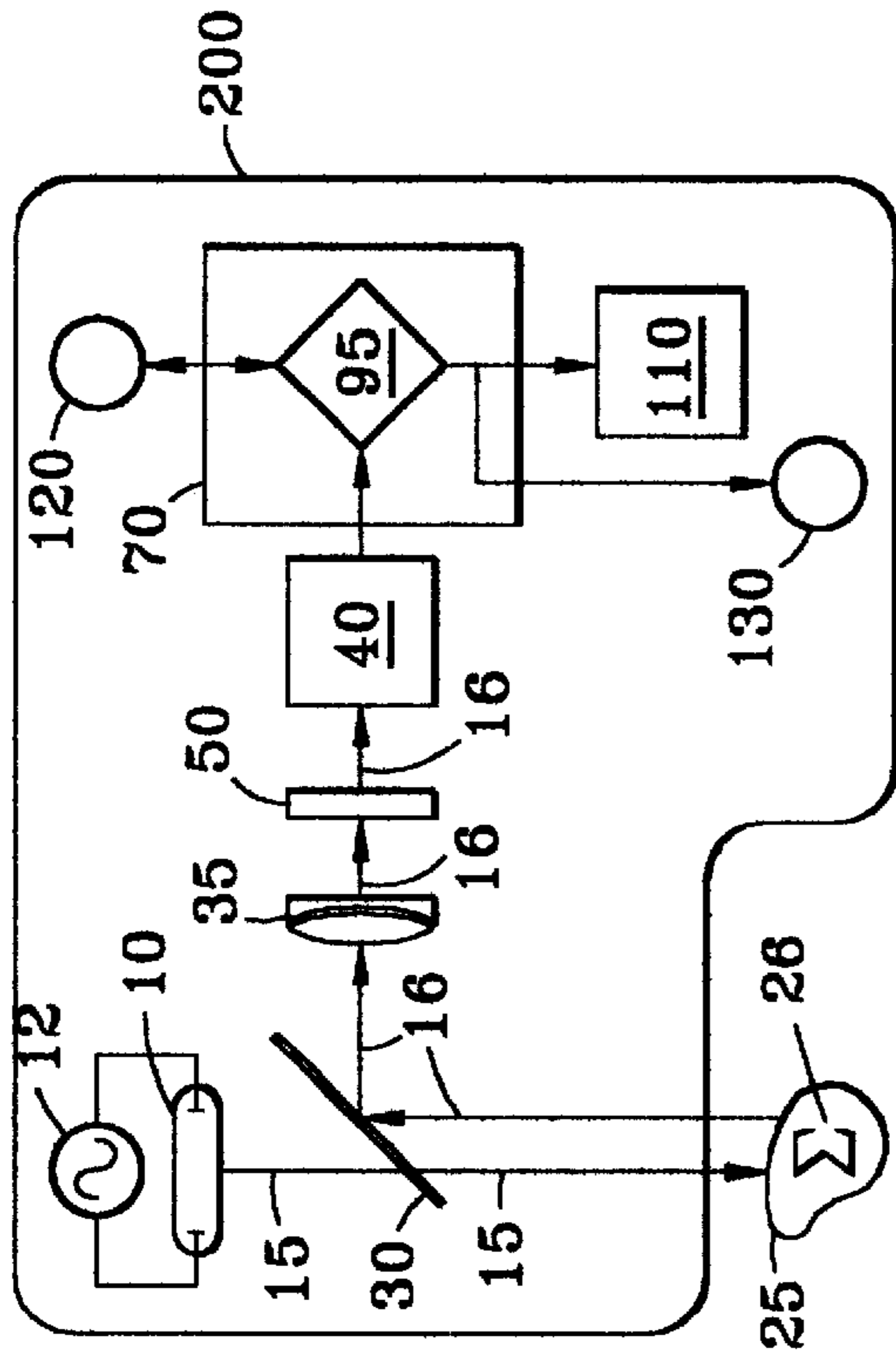

FIG. 2

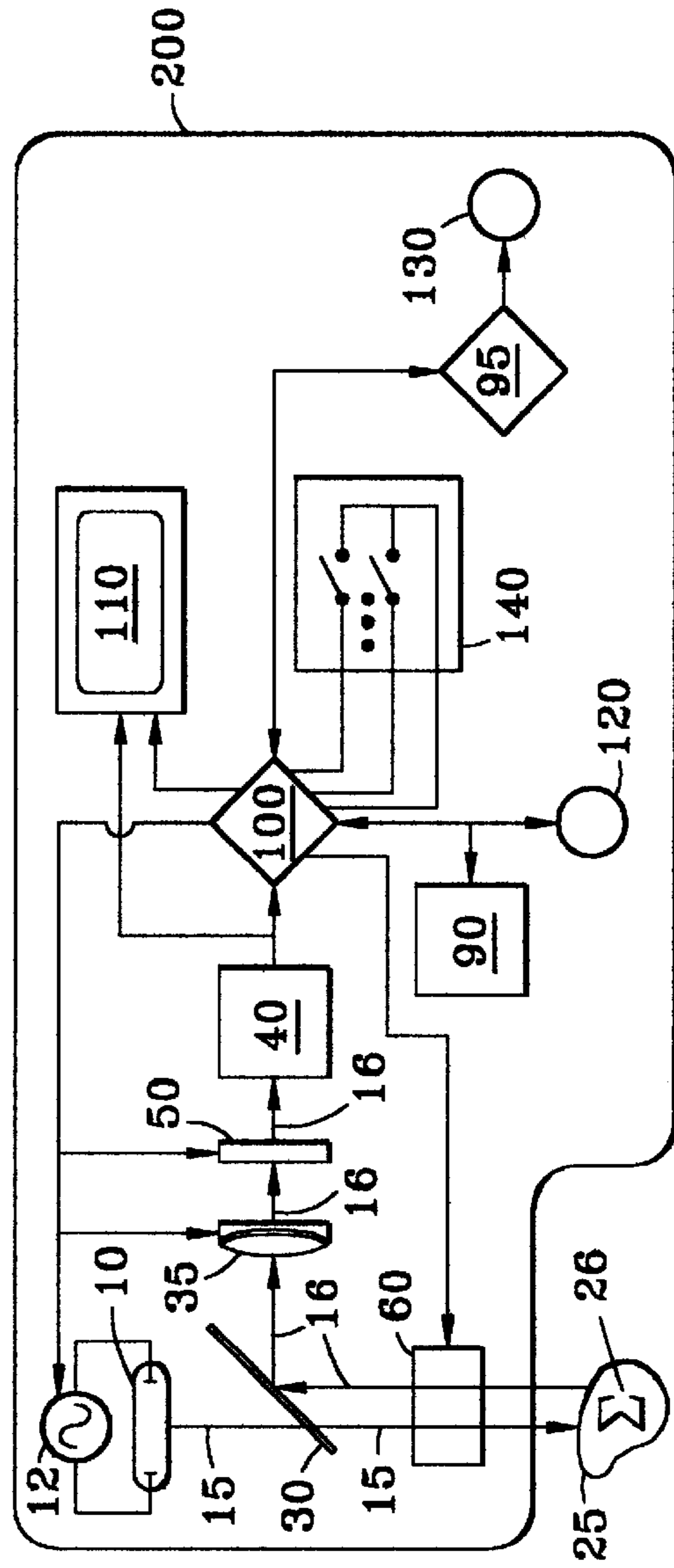

FIG. 3

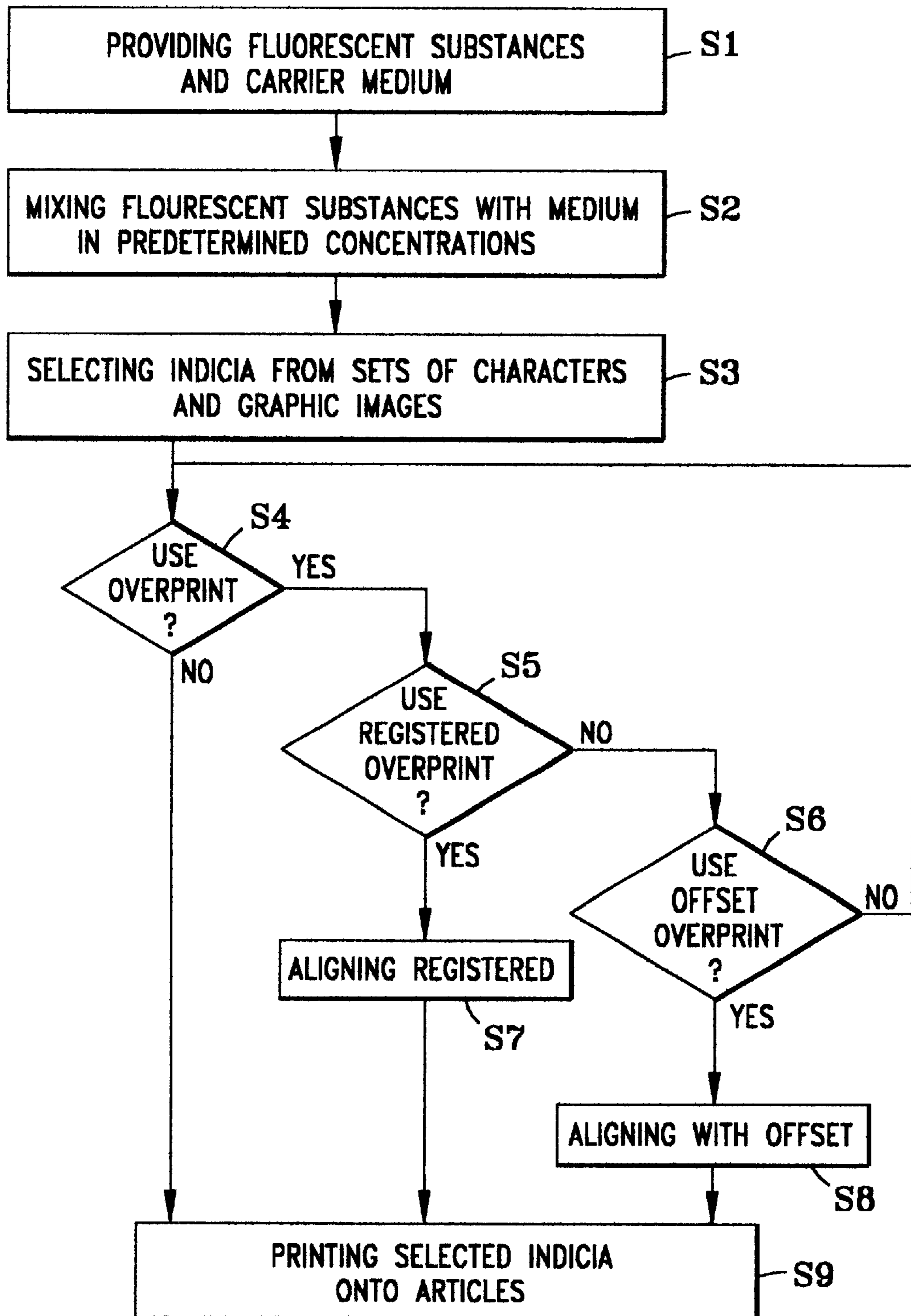

FIG. 4



FIG. 5b



FIG. 5a

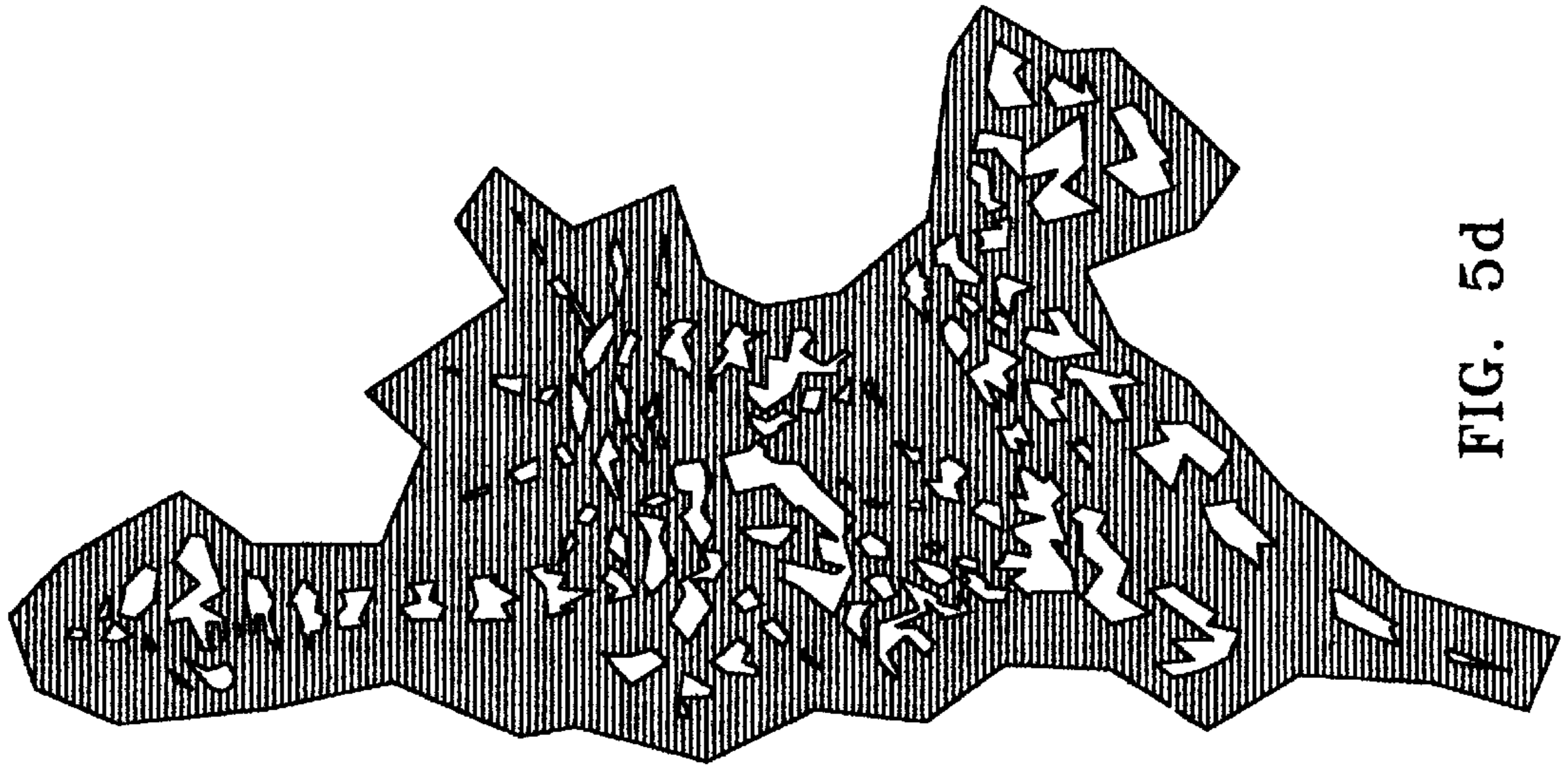

FIG. 5d

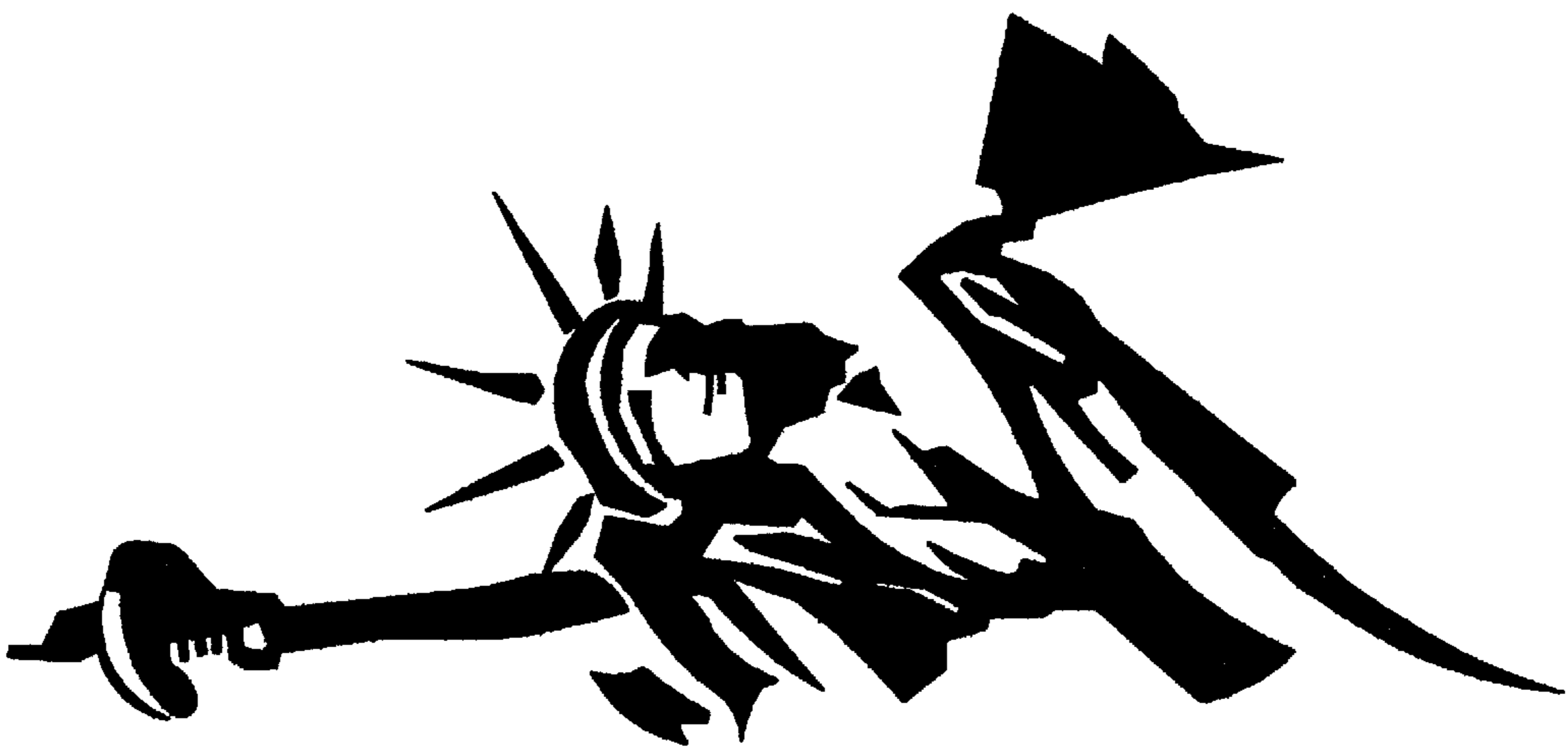
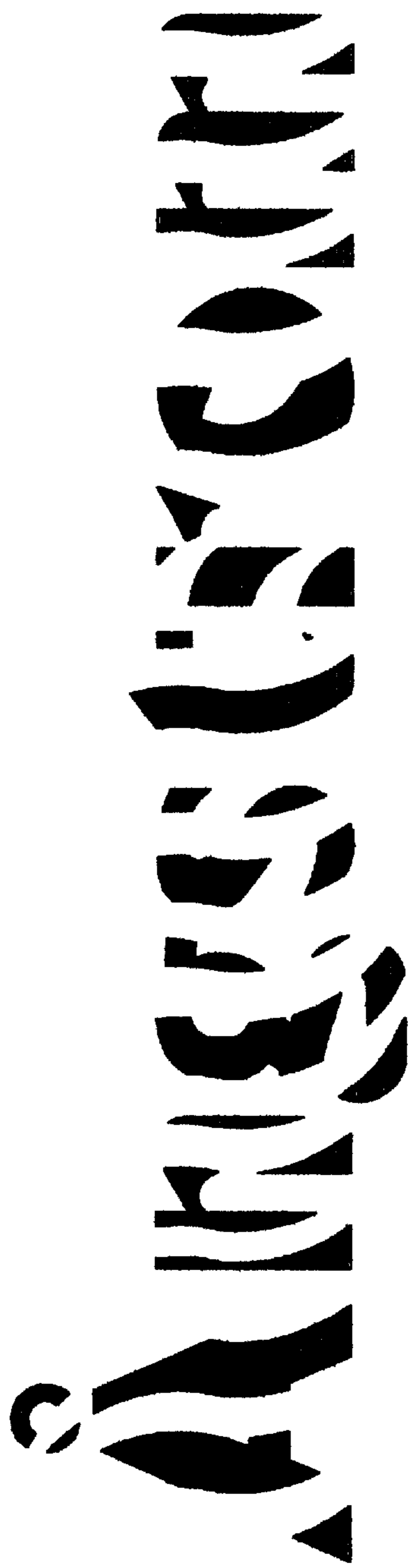

FIG. 5c



AUGUST

The image shows the word "AUGUST" in a highly stylized, decorative font. Each letter is filled with a complex, black-and-white pattern that resembles a woodcut or a traditional textile design. The letters are bold and have a slightly irregular, hand-crafted appearance.

FIG. 6a



AUGUST

The image shows the word "AUGUST" in a highly stylized, decorative font, similar to FIG. 6a. However, the decorative pattern within the letters is different, featuring a more geometric and less intricate design. The letters are bold and have a slightly irregular, hand-crafted appearance.

FIG. 6b

Ångström

FIG. 6C

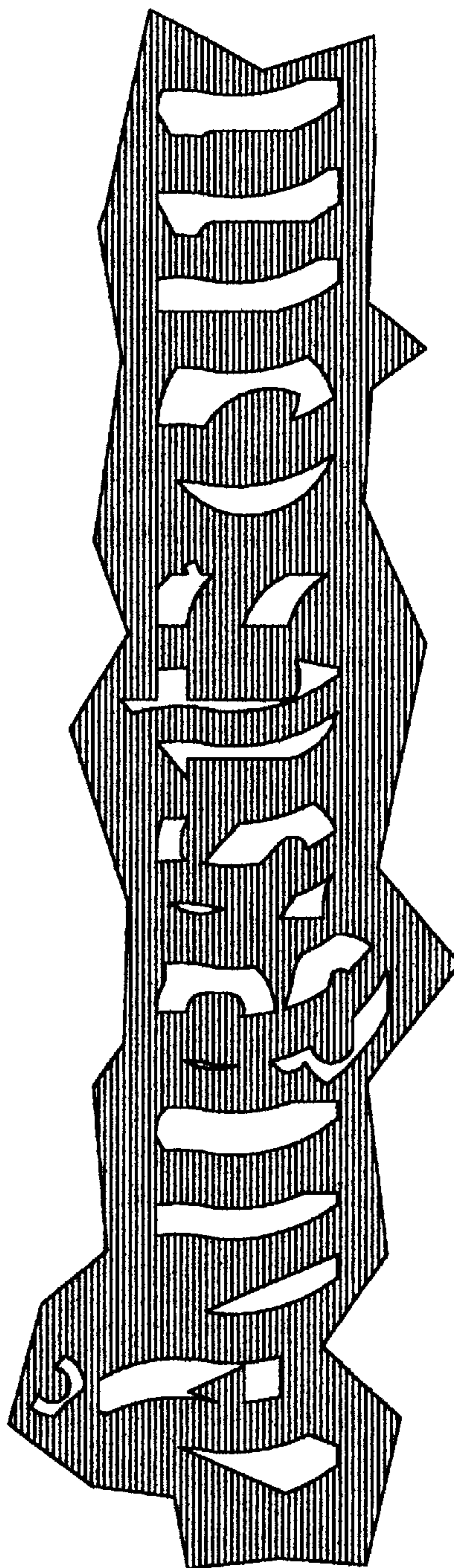

FIG. 6d

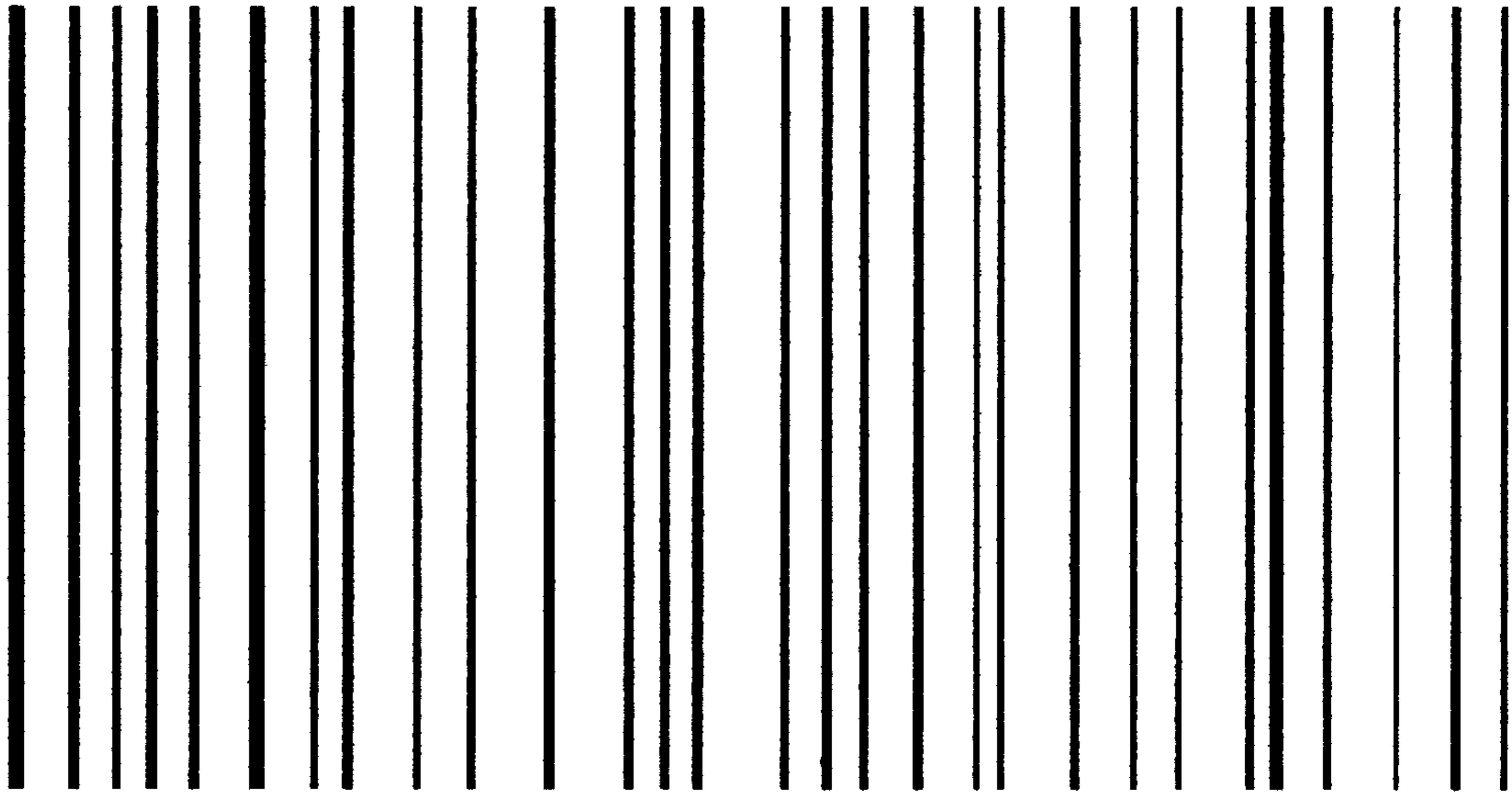

FIG. 7A

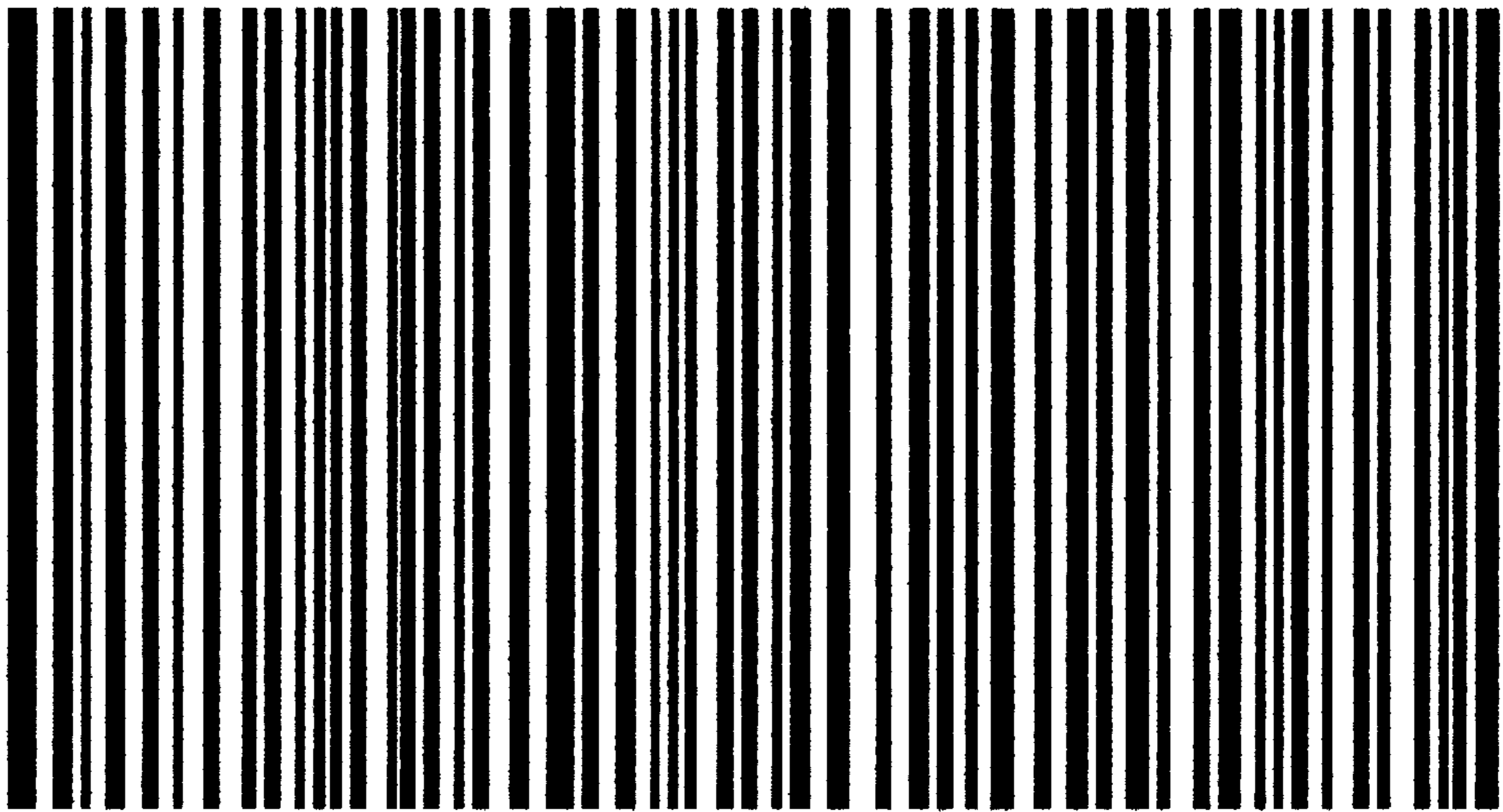

FIG. 7B

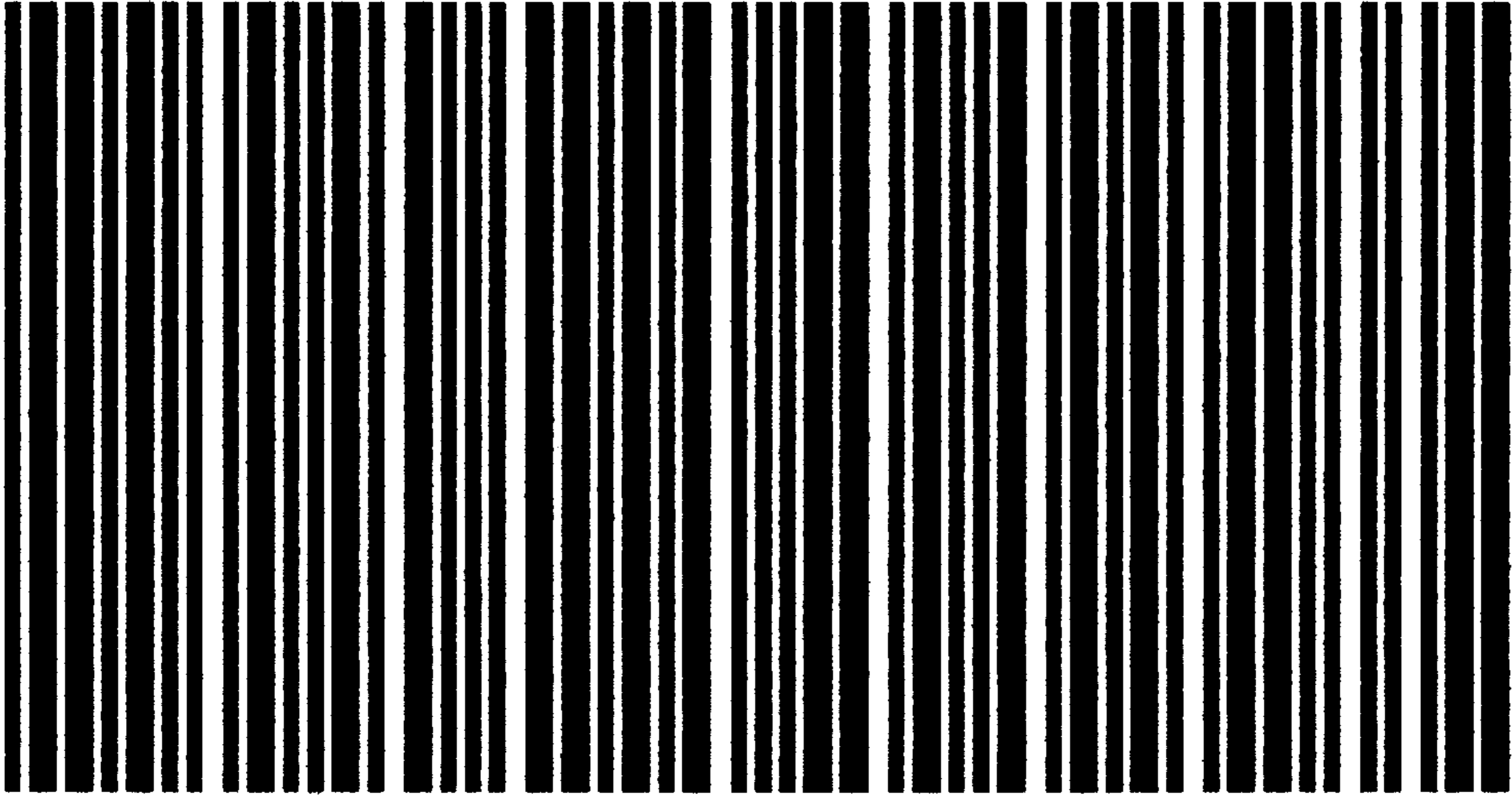

FIG. 7C

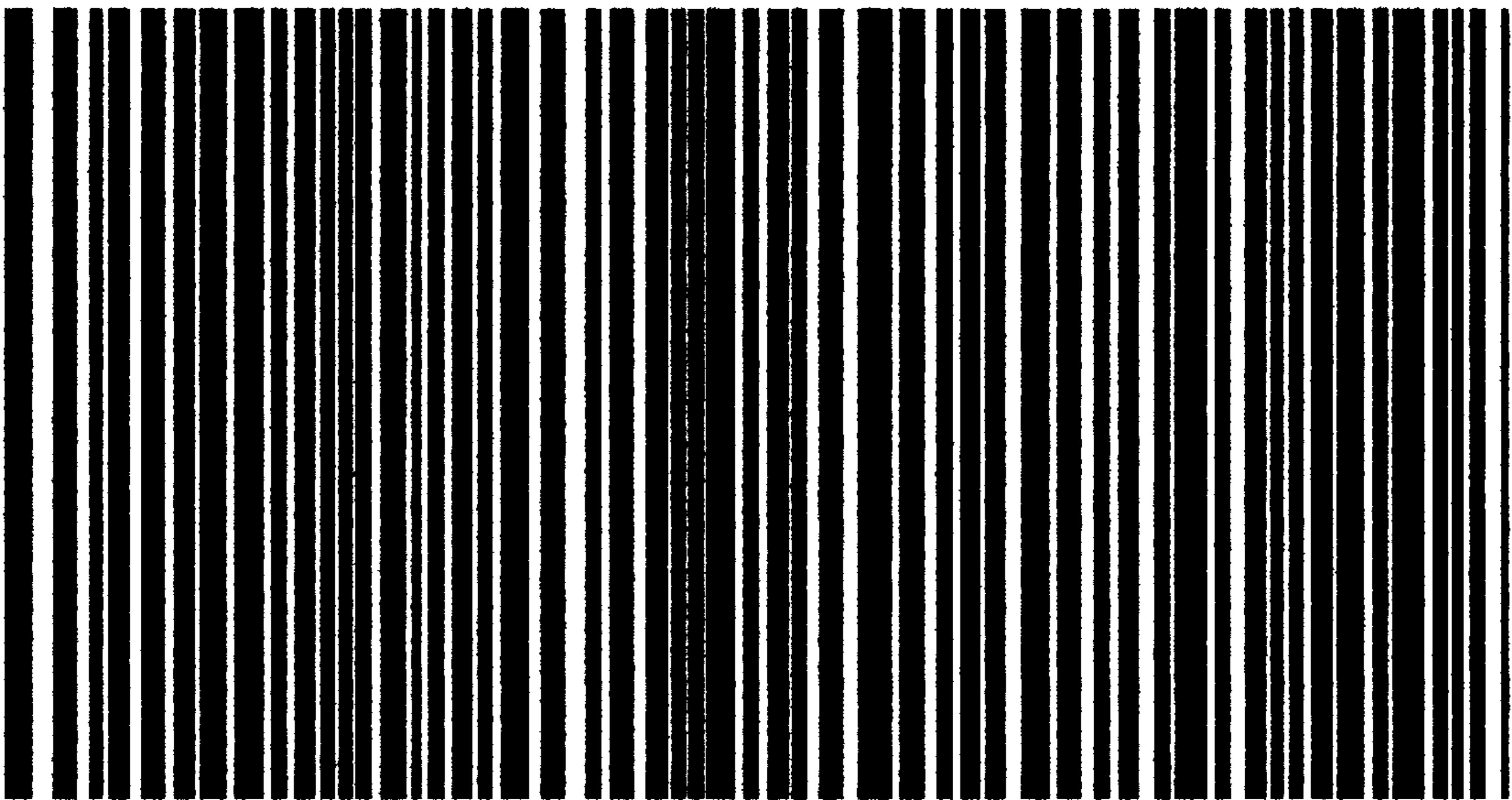

FIG. 7D

**APPARATUS AND METHODS FOR
AUTHENTICATION USING PARTIALLY
FLUORESCENT GRAPHIC IMAGES AND
OCR CHARACTERS**

**CROSS-REFERENCE TO RELATED
APPLICATIONS**

This invention is a continuation-in-part of commonly assigned application Ser. No. 09/241,555 by Liang filed Feb. 1, 1999, which was in turn a division of commonly assigned application Ser. No. 08/863,846 by Liang filed May 27, 1997, now U.S. Pat. No. 5,867,586, which was in turn a division of commonly assigned patent application Ser. No. 08/265,399 by Liang filed Jun. 24, 1994, now U.S. Pat. No. 5,719,948.

This invention is related to a commonly assigned co-pending patent application by Liang et al. entitled "Authentication System and Method," Ser. No. 08/127,250, filed Sep. 27, 1993; and to a commonly assigned co-pending patent application by Liang entitled "Apparatus and Method for Calibration of Fluorescence Detectors," Ser. No. 08/156,249, filed Nov. 22, 1993.

FIELD OF THE INVENTION

This invention relates generally to systems for authenticating articles, methods for authenticating articles, and processes for marking articles for later authentication. This invention relates particularly to mechanisms and methods for detecting indicia which may include graphic images and/or characters and for comparing the detected indicia with predetermined indicia to verify the articles' authenticity if the detected indicia are recognized. This invention relates more particularly to detection, discrimination, and recognition of fluorescent indicia rendered detectable by illumination of articles with ultraviolet light.

BACKGROUND OF THE INVENTION

Problems Solved by the Invention

The counterfeiting of articles of many kinds has become a serious problem worldwide, causing great loss of revenues to legitimate businesses and to individuals. Counterfeiting has produced articles that are very difficult to distinguish from the genuine articles, taking sales revenues from the producers of genuine articles and impacting legitimate business' reputations when the counterfeit articles have inferior quality and/or non-existent manufacturers' support. Similarly, problems and losses occur due to counterfeiting of articles used for financial transactions or identification, such as credit cards, drivers' licenses, passports, and immigration documents. Even when genuine articles have been marked with authentication markings such as watermarks, special papers, and holograms which are difficult to replicate, counterfeiters have managed to produce articles that appear genuine. The general availability of newer replication technology such as high-resolution image scanners, laser copiers and printers, and color-accurate color copiers and printers has enabled counterfeiters to produce more credible counterfeit articles. These technological developments of replication hardware continue to make rapid progress, as do the computer hardware and software that support them. Thus it is useful to have additional ways to mark articles for authentication with greater security. Greater security may be achieved by making authentication markings more difficult for counterfeiters to detect and interpret, by incorporating greater complexity into the markings, and by making rep-

lication by counterfeiters more difficult. Combining multiple kinds of marking indicia can further increase the complexity of detection, interpretation, and replication, thus providing even better security. Considering the security issue from another point of view, it is not desirable to use the same means that generated the visible appearance of an article to authenticate it, as the visible appearance is becoming easier to replicate. Invisible indicia that cannot be reproduced by common visible graphic copying and printing means can provide improved security, especially when combined with complex images, patterns, and/or characters.

Notations and Nomenclature

In this specification, the following terms or abbreviations are used with the meanings listed here:

CCD—charge coupled device

DSP—digital signal processor

excitation time—a characteristic time for a fluorescent emission to be excited after ultraviolet illumination of a fluorescent substance begins

extinction time—a characteristic time for a fluorescent emission to decay exponentially from its initial emission intensity I_0 to intensity I_0/e

IR—light in the infrared portion of the spectrum

OCR—optical character recognition

registration—the conventional definition of this term in the fields of graphic communication and printing, as defined, for example, in "Glossary of Graphic Communications" compiled by Pamela Groff and published by Graphic Arts Technical Foundation (Prentice-Hall, Inc., Upper Saddle River, N.J., 1998) at pages 245–246.

UV—light in the ultraviolet portion of the spectrum

visible/IR—light either entirely in the visible portion or entirely in the infrared portion, or partly in both visible and infrared portions of the spectrum

visible/UV—light either entirely in the visible portion or entirely in the ultraviolet portion, or partly in both visible and ultraviolet portions of the spectrum

DESCRIPTION OF THE RELATED ART

Many methods have been known to authenticate valuable articles. Some known methods include imprinting a white-light hologram or imprinting reflective and diffractive indicia which display distinctive images that are difficult to counterfeit. Other known methods include incorporation of distinctive fibers into the articles, such fibers being detectable by visual observation, microwave irradiation, or other means. U.S. Pat. No. 4,921,280 describes fibers made luminescent by a dyeing process employing rare-earth compounds, which fibers may be incorporated into articles requiring authentication.

It is known that documents may be authenticated by marking the documents with substances such as inks or dyes that appear invisible or relatively unnoticeable to the naked eye in ordinary visible illumination, but that fluoresce when illuminated with ultraviolet light, revealing marks that serve to identify the legitimate document. These methods depend on substances that are not easily or inexpensively identified by a counterfeiter, and not easily or inexpensively duplicated or mimicked by a counterfeiter. When using these methods, it is desirable to use substances such as dyes or inks that fluoresce in narrow spectral bands which are distinguishable by sufficiently narrow-band detectors, but not readily distinguishable by eye. In U.S. Pat. No. 4,146,792 by Stenzel

et al., these methods are extended to include dyes containing rare-earth elements whose fluorescence is influenced by the chemical environment of the fluorescing atoms in a non-fluorescing matrix, and the detection is refined to include detection of predetermined fine structure in the line spectrum of emitted light. Yet another class of authentication methods uses substances which fluoresce in the infrared portion of the electromagnetic spectrum when illuminated by light in the visible portion of the spectrum.

In U.S. Pat. No. 4,642,526 by Hopkins and assigned to the assignee of the present invention, a source of ultraviolet light is made self-modulating at a predetermined frequency. Detection of the secondary radiation, filtering of the detected signal, and demodulation of the filtered signal at the predetermined frequency allow the system of Hopkins' invention to detect the fluorescent marks despite interference from ambient light sources.

Marking products with indicia such as bar codes using fluorescent substances such as inks or dyes is also known in the prior art, both for the purposes described above and for providing identification on the products without detracting from the products' appearance as normally viewed in visible light. U.S. Pat. No. 4,983,817 by Dolash et al. describes methods and apparatus for reading bar codes printed with fluorescent substances, while compensating for variations in background reflectance over the area printed with the bar code. U.S. Pat. No. 5,064,221 by Mieke et al. shows the use of fluorescent substances added to ink ribbon used for printing original documents, in order to distinguish the originals from copies. In many of the known authentication methods using fluorescence, the fluorescent identifying substance may be incorporated into the article during the article's manufacture. In U.S. Pat. No. 4,451,521 by Kaule et al., for example, luminophores are incorporated into paper during its manufacture. Some of the fluorescent substances used in the prior art for authentication purposes contain heavy metals, which are not as safe or environmentally benign as substances not containing such heavy metals. While fluorescent substances have been used in many ways in the prior art to mark articles with indicia for interpretation by human observers, to our knowledge neither optical character recognition (OCR) systems nor image verification systems have been combined with fluorescent markings and UV light illumination to provide improved authentication methods.

The technology of automatic pattern recognition is described in a large body of literature including numerous patents, especially in the application area of optical character recognition (OCR). Many of the recent developments in OCR technology (especially in recognition logic software) are usable with the present invention albeit with some adaptation to the type of light source and to such contrast conditions as may differ from those encountered with conventional OCR scanners having conventional visible/IR light sources.

OBJECTS AND ADVANTAGES OF THE INVENTION

It is an object of this invention to provide an improved authentication system which can detect and recognize complex authenticating indicia such as graphic images and alphanumeric characters. It is another object of the invention to provide an authentication system which can be readily automated to provide authentication that does not depend on human subjective judgment. It is another object of the invention to combine the use of substances which fluoresce

under UV illumination, detectors capable of detecting fluorescent radiation, and image or character recognition techniques to enable the creation and authentication of articles with improved security. Another object of the invention is to enable the use of character or image indicia for authentication printed with substances that are safer and less likely to harm the environment than substances containing heavy metals. Another object of the invention is to enable the use of character or image indicia for authentication printed with substances that have sufficiently short extinction times to enable fast scanning. Another object is to enable capture of complex indicia without undue loss of resolution or smearing of details. Another object is to enable robust identification of articles of mail using mail bar codes such as "PostNET" codes printed with fluorescent substances. Another object of the invention is to enable the use of fluorescent indicia for authentication that are more complex than bar codes or simple arrays of dots and/or lines, and that allow a higher density of information per unit area than conventional bar codes. Another object is to provide an authentication system that makes counterfeiting and fraudulent labeling of articles including documents more difficult and expensive to accomplish. Another object is to provide a system that can mark articles for authentication without unduly compromising their aesthetic appearance. Another object is to provide authentication marks that are not easily removed. Another object is to provide flexible methods of authenticating articles that can be practiced in the field of use without requiring special printing press equipment. Another object is to provide an authentication system that can be re-programmed by a user to use various authentication criteria within its range of graphic image and character recognition capabilities.

SUMMARY OF THE INVENTION

An authentication system in accordance with this invention combines a source of ultraviolet light (and optionally a scanning mechanism) with apparatus for capturing and recognizing either graphic images or characters or both, where the graphic images and/or characters have been previously made with fluorescent substances that may be invisible under ordinary visible light, but are rendered detectable by the ultraviolet light. As in conventional optical character recognition (OCR), the characters may be conventional alphanumeric or other natural-language characters readable by human readers once they are made visible.

The authentication system has a housing enclosing its optical paths, a source of at least UV light, a detector for detecting graphic images or characters, conversion of the detector signal to digital form, a memory storing predetermined indicia, recognition logic, and indicators. The system may also include a scanning mechanism and optical filters to select predetermined wavelengths of fluorescent light. The detector may be capable of detecting both fluorescent images and normal visible images, and the authentication system may incorporate switching mechanisms to allow multiplexed acquisition of fluorescent and normally visible images produced by visible/IR or visible/UV illumination.

The authentication system can work in conjunction with processes performed in accordance with this invention, for marking articles with indicia selected from a predetermined set of graphic images and characters readable by optical character recognition and/or by image comparison. That process can include printing fluorescent graphic images or characters in registration (or in predetermined mis-registration) with substantially identically-formed images or characters previously printed with visible substances and/or

with fluorescent substances of different characteristic fluorescent wavelength. The recognition logic of the authentication system can include comparison of these two (fluorescent and visible/IR, fluorescent and visible/UV, or two different fluorescent) images with each other. The process can also include printing fluorescent graphic images or characters with a multiplicity of fluorescent substances having distinct fluorescent wavelengths and excitation or extinction times, and printing those in overlay with registration or with predetermined registration offset. The registration offset may be selected to produce a predetermined stereo image when properly viewed by a human observer, thus allowing "first order" authentication by visual inspection using suitable filters. Similar first order authentication may be provided by printing graphic image or character indicia which are both fluorescent and partially visible without UV illumination. Another overlay method uses two graphic images or character indicia, each incomplete in itself, with unconnected but complementary segments. When the two complementary segments are combined with appropriate registration, a complete recognizable graphic image, word, or natural language phrase is formed.

Other objects, uses, advantages and features of the invention will become apparent to those skilled in the art from the following descriptions of preferred embodiments.

BRIEF DESCRIPTION OF THE DRAWINGS

FIG. 1 is a functional block diagram of an embodiment of an authentication system in accordance with the invention.

FIG. 2 is a schematic diagram illustrating an embodiment of the authentication system.

FIG. 3 is a schematic diagram illustrating another embodiment of the authentication system.

FIG. 4 is a flow chart illustrating a process for marking articles for authentication.

FIGS. 5a-5d are related graphic images illustrating example indicia used in the authentication system for graphic image recognition.

FIGS. 6a-6d illustrate example indicia used in the authentication system for optical character recognition (OCR).

FIGS. 7a-7d illustrate example indicia used in the authentication system for barcode recognition.

DETAILED DESCRIPTION OF THE PREFERRED EMBODIMENTS

The authentication system of the present invention as considered from one point of view combines as major elements a UV light source **10** for illuminating articles to be authenticated and for excitation of fluorescent radiation, a detector **40** for detecting fluorescent radiation from indicia on the articles, and recognition logic **70** for recognizing indicia marked on the articles. Recognition logic **70** uses known methods of character recognition, such as template matching or feature extraction (topological feature analysis), to recognize characters or graphic images, which may include bar codes. The purposes of these elements and others and the relationships among them will become clear by reference to the drawings in conjunction with the following more detailed description.

FIG. 1 shows a functional block diagram of an embodiment of an authentication system in accordance with the invention. Microcomputer **100** controls the overall operation of the authentication system in FIG. 1. FIG. 1 is intended to illustrate an overall architecture or system organization of such an authentication system. Other embodiments may

vary in some details of their organization, as will be seen from the descriptions of other embodiments below. For example, in some embodiments, the functions of both recognition logic **70** and microcomputer **100** may be performed by a single digital signal processor **95** (not shown in FIG. 1, but shown performing various functions in FIGS. 2 and 3).

In FIG. 1 a UV source **10** generates ultraviolet light with which to illuminate articles to be tested for authenticity. UV source **10** may be a strobe lamp, and is preferably a high-intensity modulated lamp. In particular it may be a self-modulating lamp and associated circuit, as disclosed in U.S. Pat. No. 4,642,526 by Hopkins, the disclosure of which is hereby incorporated by reference. Light from UV source **10** passes first along an illumination portion **15** of optical path which extends to an article **25** to be authenticated. The light may pass through a beam splitter **30** and a scanner **60** before impinging on article **25** under test. The apparatus may also include an optional visible/IR source **20** whose purpose is described below. Beam splitter **30** passes light from either UV source **10** or both sources **10** and **20** along illumination portion **15** of optical path toward the articles, and passes light returned from article **25** along a return portion **16** of optical path toward detector **40**. If article **25** has been marked with fluorescent indicia **26**, at least some of the light returning along return portion **16** of optical path will be fluorescent light from indicia **26**. Beam splitter **30** may be a partially-reflective mirror or prism or a beam splitter of any type that can pass both UV light and the fluorescent light. If visible/IR source **20** is used, then beam splitter **30** must also pass visible/IR light. Optical filters **50** may be used in the return portion **16** of the optical path to select portions of the spectrum for detection. Filters **50** may be movable into and out of return portion **16** of optical path. For some applications it is desirable to insert other optical filters **50** (not shown) into illumination portions **15** of optical path between sources **10** and/or **20** and beam splitter **30**, to select portions of the UV and/or visible/IR spectra with which to illuminate article **25**. If illumination portions **15** and return portions **16** of the optical path are separated by other means, or allowed to intermix, beam splitter **30** may be omitted. For applications in which articles **25** to be authenticated are transported past the authentication system, an integral scanner **60** may not be needed and may be omitted. Otherwise integral scanner **60** scans the illuminating beam over the articles or over a selected portion of each article containing graphic image or character indicia. Scanner **60** may be a set of oscillating mirrors scanning in a two-dimensional raster for example. It will be understood by those skilled in the art that, for example, when article **25** is to be moved past the apparatus, the motion of article **25** may substitute for one direction of scan, and a detector **40** consisting of a linear array of sensors oriented perpendicular to the motion may obviate the need for a second direction of scan. If detector **40** is a single discrete photodiode, a full two-dimensional scan is needed to acquire graphic image or character data, or one of the directions of scan may be replaced with a linear motion of article **25**. Thus a wide variety of arrangements is possible with various kinds of detectors **40** and with various forms of relative motion between the authentication apparatus and article **25**.

In most applications, speed of authentication is desirable, and therefore fast detectors **40** and fast scanners **60** (if used) are desirable. This also has implications for selection of fluorescent materials with which to mark indicia **26** on articles **25**, to allow for fast scanning without undue loss of resolution or undue smearing of fine details of image or character indicia **26**. The selected fluorescent materials

preferably have short extinction time (preferably less than 10 microseconds). In embodiments having a modulated UV source **10**, the frequency of modulation is preferably selected to take into account the excitation time of fluorescence of indicia **26**. If UV source **10** is a strobe lamp type, the duration and frequency of strobe illumination are preferably selected to take into account the excitation time. Conventional means such as switches or potentiometers controlling time-constant circuits (not shown) or program instructions of microcomputer **100** are used for controlling light source modulation frequency.

Detector **40** may be a photodiode array, a CCD video camera or other detector capable of detecting fluorescent light from tested articles at the desired speed. Preferred detectors are those types that are commonly used with conventional OCR readers, preferably those that they can efficiently detect the fluorescent light. For example CCD detectors such as the ICX or ILX Series available from the Sony Corporation may be used. If detector **40** has an analog output signal, then analog-to-digital conversion circuit **80** is needed to convert that signal to digital form. It will be readily recognized by those skilled in the art that the digital form may be a binary-coded signal. Of course if detector **40** produces a digital output directly, then A-to-D conversion circuit **80** is not needed. In some embodiments of the authentication system, detector **40** may comprise a subsystem with two or more physical detector elements (not shown), each sensitive to a limited spectral range, and connected to A-to-D conversion circuit **80** (if needed) or to memory **90** through a multiplexer **45**. In this type of configuration, outputs of various detector elements are multiplexed for input to suitable separate memory addresses for comparison with each other and/or with predetermined graphic image or character data by recognition logic **70**.

A digital representation of the detected fluorescent signal data may be stored in memory **90** for comparison with predetermined image or character data previously stored in memory **90** or in a similar memory within microcomputer **100**. Microcomputer **100** may be a 68020 microcomputer, for example, available from Motorola, Inc. along with appropriate support circuitry. Microcomputer **100** operates according to program instructions stored in an internal memory or in memory **90** to control the authentication apparatus, including recognition logic **70**. While recognition logic **70** is shown as a separate entity in the functional block diagram of FIG. 1, it will be appreciated that it may be incorporated into microcomputer **100**, either as dedicated logic hardware or as instructions in the stored program of microcomputer **100**. Either recognition logic **70** or microcomputer **100** or both can activate indicators **110** to indicate the result of an authentication test. Microcomputer **100** has at least one input/output port **120** through which predetermined graphic image or character data may be loaded or changed, and microcomputer **100**'s program may be loaded and/or changed. Recognition logic **70**, which may be implemented by a program of microcomputer **100**, uses known methods for comparing characters or graphic images with predetermined characters or images.

Many methods for comparing a character or graphic image captured by detector **40** with predetermined characters or images are known, including methods such as template matching or feature extraction (topological feature analysis). The images recognized may include bar codes as well as human-readable natural language characters and simple or complex graphic images. A simple method of template matching, for example, is described in Dana H. Ballard et al. "Computer Vision" (Prentice-Hall, Inc., Engle-

wood Cliffs, N.J., 1982) Section 3.2.1 (p. 65 ff.). Other methods of verifying images are discussed in Azriel Rosenfeld et al. "Digital Picture Processing" (Academic Press, New York, N.Y., 1976) particularly in Chapter 10 Section 10.4 and in references cited there (pp. 404-450). More recently developed methods are described in the extensive patent and publication literature of optical character recognition and pattern recognition. See for example J. R. Ullman, "Advances in Character Recognition" (pp. 197-236) in K. S. Fu, Ed. "Applications of Pattern Recognition" (CRC Press, Inc., Boca Raton, Fla., 1982) and "Proceedings of 10th International Conference on Pattern Recognition" (IEEE Computer Society Press, Los Alamitos, Calif., 1990) Vol. 1 and 2, especially Vol. 1 pages 443-473 and 551-582, and other proceedings of that conference series.

It will be understood that microcomputer **100** may be programmed for its various modes of operation by hardware mode-selection switches (not shown), or by loading appropriate software instructions into its program memory through input/output port **120**. For example, microcomputer **100** may be programmed to compare two multiplexed images in real time, pixel by pixel, such as a fluorescent image and a visual/IR image, using the software equivalents of a sample and hold circuit and a comparator circuit. Alternatively, these functions can be provided in conventional circuit hardware. With appropriate timing, and with optical alignment of two detectors **40**, two multiplexed images may be compared in real time, pixel by pixel, without use of memory **90**. The two images may be a conventional image detectable with visible-light illumination and a fluorescent image detectable under UV illumination, or two distinct fluorescent images having different fluorescent wavelengths, both made detectable by UV illumination. Mode-selection switches, mentioned above, may be used to select an image-comparison mode to operate in this manner. The optical alignment of detectors **40** for image-comparison operation may include a predetermined optical axis offset between two or more detectors. In the simplest embodiment of such a system, the offset is zero, and two or more images must be printed in registration, i.e. each image printed accurately aligned with the other(s), within a predetermined tolerance. If they are registered within the required tolerance, the system produces a positive indication of authenticity, via indicators **110**.

Another mode of operation is an offset-image-comparison mode. This mode may be selected by mode-selection switches or under control of a stored program of microcomputer **100**. A predetermined offset may be switched on or off by a user. Yet another mode of operation selectable by switches or by stored-program control is a "missing-link" image mode. In this mode of operation, one image contains an incomplete image which is missing certain elements or segments of a complete image. That incomplete image may be a visible image or one made visible only under UV illumination. For a "missing link" mode of operation, at least one additional image must be printed which contains the missing segments, filling in a complete image. Only under UV illumination will the complete image be detected by detectors **40** and recognized by recognition logic **70**.

If the two images have opposite contrast (i.e. one has relatively bright indicia on a darker background and the other has dark indicia on a brighter background), then one image is reversed by recognition logic **70** before the two images are combined. The two images may then be combined by a registration operation and an addition operation. For binary images, the addition may be a logical non-exclusive OR operation. Both images may contain a com-

mon element of a convenient design such as a cross to be used for registration.

Conventional switches may be used in conventional arrangements to actuate movement of optical filters **50** into and out of illumination portion **15** and/or return portion **16** of the optical path. These filter movements may be controlled by microcomputer **100** through its stored program instructions, instead of or in addition to switches manually operated by a user.

FIG. **2** is a schematic diagram illustrating a first physical embodiment of the authentication system. The system has a housing **200**. Housing **200** holds and encloses other elements of the system, maintaining optical alignment, shielding the optical paths from stray light, and protecting the user from unnecessary exposure to UV light. Housing **200** should enclose at least the illumination portion optical path portion **15**, UV source **10** and visible/IR source **20**, splitter **30**, filters **50** if any, and detector **40**, and may enclose all other elements as well. For some applications it may be convenient to enclose only the illumination portion optical path **15**, source(s) **10** and/or **20**, splitter **30**, filters **50** if any, and detector **40** in housing **200**, and to house the remaining elements of the system separately, connected to the elements in housing **200** with a cable or with wireless transmitter and receiver means (not shown) such as radio, ultrasonic or infrared. Of course elements within housing **200** and subject to illumination by illumination portion optical path **15** or by any scattered UV light should not themselves be fluorescent in a spectral range to be detected.

In FIG. **2** UV source **10** is energized by energizing circuit **12**, which may incorporate components making UV source **10** a self-modulating lamp as discussed above with reference to FIG. **1**. Light propagating along illuminating optical path portion **15** from source **10** illuminates the article **25** to be authenticated, which may carry authenticating indicia **26** printed on it in accordance with methods of the invention. Light returning along return optical path portion **16** is separated from illuminating portion by beam splitter **30** or equivalent means. Beam splitter **30** may be a partially reflective mirror or a suitable prism transparent to UV light in the direction of illuminating portion optical path **15**. Return portion optical path **16** is focused by focusing element **35** so as to produce an image of article **25** at detector **40**. Optical filter **50** may be used to select portions of the optical spectrum to be detected.

Detector **40** is preferably a CCD array detector such as a CCD video camera. For some applications, however, detector **40** may be a simpler and less expensive linear detector array as discussed above with reference to FIG. **1**. It is important that detector **40** in combination with other elements of the invention produce sufficient graphic or character data with sufficient resolution and contrast for optical character recognition and/or image comparison by recognition logic **70**. In FIG. **2**, detector **40** is of a type producing a digital output. Recognition logic **70** may be implemented by use of a digital signal processor (DSP) **95**, as shown in FIG. **2**. In this embodiment digital signal processor **95** performs combined functions of microcomputer **100** and recognition logic **70** of FIG. **1**, and may also incorporate memory **90**. If detector **40** were of a type producing analog outputs, DSP **95** could also perform the function of analog-to-digital conversion **80** shown in FIG. **1**. DSP **95** may be a DSP56000, available from Motorola, Inc. for example, along with appropriate support circuitry.

Recognition logic **70** connects to an input/output port **120**, through which the program under which DSP **95** operates

may be loaded. Predetermined character and/or graphic image data may also be loaded through port **120**, and this or other information may be read out. The other information to be read out may include statistical information gathered by DSP **95** over a period of time, over a number of characters or images tested, or over a number of authenticity determinations made. Recognition logic **70** also connects to indicators **110** and electrical output port **130**. When recognition logic **70** has completed a character-recognition operation or image-comparison operation (or set of such operations) and reached an authentication result (positive or negative), the authentication result is displayed on indicators **110** and/or transmitted to electrical output port **130**. Output port **130** may be a relay output, a standard logic output such as TTL, a current loop output, or the like to control other apparatus outside the authentication system apparatus. Indicators **110** may consist of lightemitting diodes, a liquid-crystal display, a cathode-ray tube video display or the like to convey an authentication result to a human user of the apparatus. In the simple embodiment of FIG. **2**, no scanner **60** is used, and no separate memory **90** is used. This embodiment can be used, for example, in an "overlay method," described in detail below.

FIG. **3** is a schematic diagram illustrating a second physical embodiment of the authentication system. The embodiment of FIG. **3** combines many of the same elements as in the simpler embodiment of FIG. **2** along with additional elements to provide a more flexible authentication system. A housing **200**, UV light source **10**, energizing circuit **12**, beam splitter **30**, focusing optical element **35**, optical filter **50**, detector **40**, input/output port **120** and electrical output port **130**, all of these perform the same functions as the corresponding elements in FIG. **2**. In FIG. **3**, microcomputer **100** controls the overall operation of the authentication system. Control switches **140** allow selection of various operating modes by the user. Memory **90** stores predetermined character or graphic image data, and image data acquired by detector **40**, under control of microcomputer **100**. The function of recognition logic **70** is performed by the combination of microcomputer **100** and DSP **95**. Operating parameters of several elements are controlled by microcomputer **100**. A modulation frequency of UV source **10**, for example may be controlled by microcomputer **100** by varying the frequency of trigger pulses or by switching various capacitors into a resonant circuit including the lamp of UV source **10**. The axial position of focusing optical element **35** may be controlled by actuating a stepper motor with pulses from microcomputer **100**. The positions of filters **50** may be similarly controlled to move filters **50** into or out of an optical path. The operation of detector **40** may be controlled by microcomputer **100**, including synchronizing an image acquisition operation with the operation of UV source **10**. Scanner **60** scans article **25** for those applications that require scanning, and its frequencies and amplitudes of scanning may be controlled by microcomputer **100**. In the embodiment of FIG. **3**, indicator **110** may display a processed image and/or a raw, unprocessed image of article **25** or indicia **26**.

It will be understood that microcomputer **100** may be programmed for its various modes of operation by hardware control switches **140** selecting the various modes, or by loading appropriate software instructions into its program memory through input/output port **120**.

FIG. **4** is a flow chart illustrating a process for marking articles for authentication in accordance with the invention. First (S1), a suitable carrier medium and predetermined fluorescent substances are provided. The carrier medium

may be a non-fluorescent transparent solvent or liquid plastic. The fluorescent substances are preferably substances which fluoresce in the blue portion of the optical spectrum at about 465 nanometers wavelength, substances which fluoresce in the green portion of the optical spectrum at about 510 nanometers wavelength, substances which fluoresce in the yellow portion of the optical spectrum at about 530 nanometers wavelength, and mixtures of those substances, which may be easily distinguished using readily available optical filters. Fluorescent substances are preferred which fluoresce in the portions of the optical spectrum between 455 and 475 nanometers wavelength, between 500 and 520 nanometers wavelength, between 520 and 540 nanometers wavelength, and between 580 and 630 nanometers wavelength, and their mixtures (in the same indicia) or combinations (in different indicia). Suitable substances are Angstrom No. 5, Angstrom No. 4, and Angstrom No. 6, available from Angstrom Technologies, Inc., which fluoresce in the first three above-mentioned spectral ranges respectively, and pentacene ($C_{22}H_{14}$) which fluoresces in the fourth above-mentioned spectral range. Fluorescent substances to be used in the methods of this invention may include substances and chemical compositions as described in U.S. Pat. No. 4,642,526 by Hopkins, the disclosure of which is hereby incorporated by reference. It is especially preferred to provide fluorescent substances without heavy metals (i.e. having metals, if any, with atomic numbers less than or equal to 20). These are safer and less likely to harm the environment than substances containing heavy metals. It is also especially preferred to provide substances that have sufficiently short extinction times to enable fast scanning for capture of complex indicia without undue loss of resolution or smearing of details.

The fluorescent substances are mixed (step S2) with the carrier medium in predetermined concentrations. Preferred concentrations are less than 10% by weight, and even more preferred, less than 1% by weight.

In step S3, indicia are selected from predetermined sets of characters or graphic images suitable for recognition. The predetermined characters preferably include a font of characters standardized for optical character recognition. Examples of such standardized character sets are OCR-A, OCR-B, E-13B, OCR-A Eurobanking and OCR-B Eurobanking. For mail sorting or authentication, standardized postal bar code indicia such as the "PostNET" code are preferred. Preferred indicia for other authentication applications are more complex than bar codes or simple arrays of dots and/or lines. However, it should be noted that the methods of this invention are not limited to Roman alphabet fonts or fonts especially designed for OCR, but may be used with a wide variety of character indicia, including characters of foreign languages such as Cyrillic, Chinese, Japanese, Hebrew and Arabic language characters, and an even wider variety of arbitrarily designed graphic images.

At this point in the process, a series of decisions are made which determine whether indicia to be printed will be aligned with previously printed marks. The first decision (step S4) is whether an overlay method will be used. If not, the selected indicia are printed without alignment (step S9). If an overlay method is to be used, the decision made in step S5 determines if it is to be registered overlay. If so, the selected indicia are aligned in registration with previously printed indicia (step S7), and then printed (S9). If the method is to be an offset overlay (decided in step S6), then the selected indicia are aligned with a predetermined offset (S8), and then printed (S9). Many methods of alignment or registration of printed indicia are known in the art, including the methods used to register the various color levels in color offset printing.

The methods of the invention as illustrated by the method of FIG. 4 may be used on a variety of articles, including articles made of paper, synthetic paper, tamper-resistant paper, cardboard, fabric, plastic film, ceramic, metal and glass.

The invention will be further clarified by considering the following examples, which are intended to be purely exemplary of various ways to use the invention.

The authentication system is easy to use and flexible in its uses. In a first phase of using the invention, the articles to be authenticated are marked by a process in accordance with the flow diagram of FIG. 4. The images may be graphic representations of a company's logo, for example. Or the indicia may be a series of English alphanumeric characters coding some unique characteristics of the article being marked. In a second phase of using the authentication system, a determination is made whether particular articles have been so marked.

In one method of using the authentication system, the graphic images and/or characters to be recognized are stored in memory 90 using input/output port 120. Articles to be tested for authenticity are moved past the optical input of the authentication system if it is of a type not having an integral scanner 60. If the authentication system does have an integral scanner 60, relative motion of the system and the articles is not needed (nor is relative motion desirable). In either case, UV source 10 illuminates the articles, and detector 40 captures an instantaneous image. Recognition logic 70 will automatically indicate authentication only if the detected graphic image or characters match the stored image data to within predetermined criteria and their tolerances.

In another method of using the authentication system (here termed "overlay method"), there are again two phases. In the first phase, indicia selected from a predetermined set of images or characters recognizable by the authentication system are printed on articles with ordinary visible ink. These indicia may represent a serial number, for example. The same images or characters are printed on the same articles with fluorescent ink prepared as described above. Preferably the second printing is printed over the first (visible) printing in registration with the visible printing. Thus it would not be apparent that the article carried additional non-visible markings. Useful alternatives include printing indicia with ink fluorescent in one preselected wavelength over identical indicia fluorescent in a different preselected wavelength, or printing first fluorescent indicia over either visible or second fluorescent indicia with a predetermined registration offset—i.e. shifted by a predetermined distance and direction from the first printing. The latter may be called an "offset overlay method." In a further application of the offset overlay method, the overlay offset and the two overlaid images may be selected to produce a predetermined stereo three-dimensional image when viewed from normal near-point reading distance (25 cm.) by a human observer through suitable filters differing for the observer's two eyes. This application ("stereo offset overlay") allows a human observer to accomplish a "first-order" authentication—i.e. an authentication with less precision and certainty than that performed by methods using the apparatus of this invention. First-order authentication may be conveniently used at a point-of-sale, immigration or customs checkpoint, etc. for a rapid informal check on an article's authenticity. As there is some variation among observers with respect to inter-ocular spacing, and in their ability to easily assimilate variously spaced stereo pairs of images presented separately to their eyes, there is a range of

offsets that provides three-dimensional appearance, which will vary somewhat in apparent depth depending on the observer. The stereo pair of images may be of the type commonly called "random dot stereograms," in which no structure is evident to the human eye until the stereogram images are fused to produce a three-dimensional effect.

This completes the first phase of using the system in the overlay method. The second phase of the overlay method is using the authentication system to determine if the indicia are authentic. For this second phase, the authentication system is switched to "overlay detection" mode. In this mode the authentication system scans the article first with visible/IR light and (after conversion to digital form) stores the visible/IR image data. It then scans the same article with UV light and stores the (digitally converted) fluorescent image data. These two scanning, detection, conversion and storage sequences can be quasi-simultaneous operations by using the multiplexing option described above. The recognition logic compares the digital data stored from visible/IR and fluorescent image scans (performing a software registration if necessary), and indicates a positive authentication result if and only if the two images agree within the programmed tolerance. If the images have been intentionally printed with a predetermined offset (offset overlay method), then the recognition logic is programmed to test for the predetermined registration offset (to within a predetermined tolerance) as well as for correspondence of the indicia. This offset testing may be done, for example, by first utilizing known methods of registering similar images (such as maximizing a cross-correlation coefficient). Then the offset distance and direction required to achieve best registration is determined. The test is completed by comparing that offset with the predetermined offset. The same method may be used for automatic testing of stereo offset overlay images. Other stereo image interpretation methods may also be used (such as those discussed in W. Luo and H. Maitre at pages 60-64 in Vol. 1 of "Proceedings 10th International Conference on Pattern Recognition" cited above, and in other papers in those proceedings and those of other conferences in that series).

In a variation of the overlay methods described above (here termed "missing link overlay"), the two overlaid images may comprise a complementary pair in which detailed elements of one member of the pair complete a recognizable image by filling in detail elements missing from the other member of the pair. One member of the pair is again printed with visible ink or a first fluorescent ink, and the other member of the pair is printed in a fluorescent or a second fluorescent ink respectively. For example indicia in one member of the pair may comprise portions of characters of a complete English word or phrase, and the other indicia may comprise the remaining portions of those characters, such that either image alone is not readily recognizable by a human observer or by a conventional OCR system, but when the two indicia are combined by the system of this invention, the complete word or phrase may be recognized. A simple example of non-character missing-link images is a pair of images, each containing different portions of a complete recognizable object, such as a bicycle. Thus the missing link overlay method also allows first-order authentication by a human observer.

It will be noted that some of the methods of using the invention may require (as part of the automatic image acquisition process or recognition process), contrast reversal of an image or of one image of a pair, while not requiring contrast reversal of the other image of a pair. Thus for example, while indicia printed with visible ink may be

recognized by conventional OCR apparatus, other indicia printed with fluorescent ink may have bright indicia against a darker background, and thus may require contrast reversal before recognition by similar recognition logic. With digital representation of the detected indicia, any required contrast reversal is easily incorporated into the program of micro-computer 100 or DSP 95.

As mentioned above, the system can be used in a "missing-link" mode of operation in which the graphic image(s) and/or OCR-recognizable characters are formed by combining first portions visible under visible light illumination with second portions visible only under non-visible illumination, e.g. by virtue of fluorescence of the second portions. In this missing-link method, the entire graphic image or the entire OCR-readable text is not apparent to a human observer or recognizable by a human observer under ordinary ambient visible-light lighting conditions.

The operation of the authentication system in its "missing-link" mode of operation is now illustrated by the examples shown in FIGS. 5a-5d and FIGS. 6a-6d. FIGS. 5a-5d show examples of indicia used in the authentication system for graphic image recognition in the "missing-link" mode of operation. It will be seen that none of the indicia of FIGS. 5a, 5b, and 5d is individually recognizable by a human observer, while the combination in FIG. 5c is readily recognizable by a human observer as the Statue of Liberty. The indicia of FIG. 5a consist of selected fragments of the indicia of FIG. 5c. The fragments in FIG. 5a may together comprise any desired fraction of the image area of the indicia of FIG. 5c, for example, but these fragments are preferably selected to be approximately half of the image area of FIG. 5c. The fragments in FIG. 5a may be selected by a random or pseudo-random process so as to avoid being readily predictable by a counterfeiter. In use of the invention, the indicia of FIG. 5a are printed with ink visible under illumination with visible light. Thus, under illumination with visible light alone, only the unrecognizable indicia of FIG. 5a are seen by a human observer. Indicia corresponding to either FIG. 5b or FIG. 5d are printed with ink visible only under illumination with non-visible light, e.g. fluorescent ink. Some especially suitable fluorescent substances visible only under UV illumination, for example, are the Angstrom SC254, SC25, and SC138 fluorescent materials, commercially available from Angstrom Technologies, Inc. of Erlanger, Ky. Other suitable substances are described in U.S. Pat. No. 5,714,291 to Marinello et al., the entire disclosure of which is incorporated herein by reference. Conventional fluorescent inks visible only under UV may be used for some applications. The selection of indicia of FIG. 5b or FIG. 5d is determined by relative contrast considerations and/or by a tradeoff with complexity of the authentication system, as explained below. For understanding of the missing-link method, it is sufficient at this point to consider the indicia of FIG. 5b and their relationships with those of FIG. 5a. The indicia of FIG. 5b are printed with ink visible only under illumination with non-visible light, e.g. with fluorescent ink, and are printed in registration with the indicia of FIG. 5a, i.e., aligned with the indicia of FIG. 5a to within a predetermined precision. Like the indicia of FIG. 5a, the indicia of FIG. 5b consist of selected fragments of the indicia of FIG. 5c, but those fragments in the indicia of FIG. 5b are generally the fragments missing from the indicia of FIG. 5a. Thus, the indicia of FIG. 5b provide the missing link (missing from the visible indicia of FIG. 5a) needed to form the complete indicia of FIG. 5c.

As in FIG. 5a, the fragments in the indicia of FIG. 5b taken together may also comprise any desired fraction of the

image area of the indicia of FIG. 5c that is at least the complement of the fractional portion represented by FIG. 5a, but are also preferably selected to be approximately half of the image area of the indicia of FIG. 5c. It will be understood that the fragments in the indicia of FIG. 5b may not be selected by a random process entirely independently from the selection in FIG. 5a. However, there may be some overlap in the two portions if desired, and that overlap portion may be selected by a random or pseudo-random process so as to avoid being readily predictable by a counterfeiter.

FIG. 5d illustrates an alternative to FIG. 5b, taking into account the relative contrast of the inks used and the common background. In some situations it may be necessary to use an image like that of FIG. 5d instead of one like FIG. 5b, because in use, the indicia of FIG. 5a are printed with ink darker than the background, while the ink visible only under illumination with non-visible light, e.g. fluorescent ink, is brighter than the same common background. The indicia of FIG. 5d differ from the indicia of FIG. 5b essentially in having reversed contrast. Such reversed contrast printing is not necessary, however if human recognition of the completed image such as the indicia of FIG. 5c is not required, as the logic of the authentication system hardware or software can include a logical inversion of the contrast obtained with illumination with non-visible light. Such inversion adds some complexity and cost to the authentication system hardware or software, which complexity and cost may be avoided by the use of indicia such as the indicia shown in FIG. 5d.

The missing-link mode of operation has been described above in terms of combining first portions visible under visible light illumination with second portions visible only under non-visible illumination. The same principles are also applicable in situations that benefit from having both portions visible only under non-visible illumination. For example, referring again to FIGS. 5a-5d, FIG. 5a may be printed in ink visible (having a first fluorescent color) only under invisible ultraviolet (UV) illumination characterized by certain first wavelengths of ultraviolet light and FIG. 5b printed in ink visible only under invisible infrared (IR) illumination. The portions visible under UV may be inks containing the materials mentioned above, available from Angstrom Technologies, Inc. of Erlanger, Ky., for example. The portions visible only under IR illumination may be printed in inks such as SICPA Securink infrared ink 171075A, optionally used with ink 171055A, both commercially available from SICPA Management S.A. of Prilly, Switzerland (SICPA Securink of Springfield, Va. in the United States). Similar inks are available in wet- or dry-offset and screen-printing versions. Or, alternatively, FIG. 5b may be printed in ink visible with ink having a second fluorescent color under illumination by the invisible ultraviolet illumination of the same first wavelengths of ultraviolet light that reveal the indicia of FIG. 5a. Yet another combination uses two substances that require different wavelengths of UV light, e.g. one ink visible in long-wavelength UV and one ink visible in short-wavelength UV. Both wavelengths of UV illumination are then provided to complete the image. In each of these alternative methods, the complete indicia of FIG. 5c are visible only when the appropriate combination of invisible illuminations is provided. Thus, important variables available to be controlled for implementing the missing-link method of the present invention are the wavelengths of invisible illumination employed (combined either with each other or with visible illumination) and the responses of inks (e.g., their

fluorescence, reflectance, transparency, or contrast) in response to illumination with the various wavelengths. Other variables may also be controlled, such as the background color, fluorescence of the background, optical filtering of the illumination, or optical filtering in the optical path used for detecting the indicia. Thus, the missing-link method of the present invention may be practiced with any combination of multiple portions printed in registration with each other, of which one or more portions are printed with a substance visible only under non-visible illumination so that the complete combination of portions (fitting together to form a single complete image or OCR-recognizable text) is recognizable only when suitable illumination is applied. The one or more portions that are printed with a substance visible only under non-visible illumination may be thought of as the link(s) that are "missing" in the missing-link method since they are not detectable under ordinary visible illumination.

For simplicity and clarity of exposition, the following description returns to the combination previously described, viz., first indicia portions visible under visible light illumination combining with second indicia portions visible only under non-visible illumination.

It will be recognized that the missing-link mode of operation requires that the indicia printed in ink visible under ordinary visible-light illumination (e.g. the indicia of FIG. 5a) and the indicia printed in ink visible only under illumination by non-visible light (e.g. the indicia of FIG. 5b) must be properly registered with respect to each other on the article in order to form the indicia of FIG. 5c by their superposition. Here, of course, "registration" refers to alignment of the indicia so that corresponding points are coincident. Such registration requires positioning the respective images in their "x and y" locations on the article to within a predetermined tolerance. That tolerance will typically be the maximum error in lateral alignment of the indicia relative to each other. The registration of printed indicia and various methods for achieving proper registration are well known in the printing arts, especially in the field of conventional half-tone color printing where three or four separate color component indicia must often be printed in precise registration.

It should also be recognized that fluorescence, while sufficient in many instances for an image portion to be visible only under non-visible illumination, is not a necessary characteristic of a substance used to print such an image portion. Another characteristic useful in this regard is the contrast of a substance with a background. Thus, FIG. 5a may be printed with ordinary ink on a suitable background against which it is visible under ordinary visible illumination. FIG. 5b may be printed with a different ink on the same background, against which it is not visible under ordinary visible illumination because of insufficient contrast (e.g., due to relative reflectance, transparency, or color contrast). In accordance with the present invention, FIG. 5b may be printed to be visible under ultraviolet (UV) or infrared (IR) illumination because of the contrast of its ink with the background under either or both of those non-visible illuminations. FIG. 5a remains visible in this example, either because it is also visible under the non-visible illumination, or there is sufficient visible illumination present in the ambient environment, or applied by suitable apparatus. The same considerations regarding relative contrast apply in this situation, analogously to the discussion of FIG. 5d above. Again, even without fluorescence, the recognizable combination FIG. 5c becomes recognizable with suitable illumination that completes the "missing link."

FIGS. 6a-6d show examples of indicia used in the authentication system in the "missing-link" mode of operation for

optical character recognition (OCR). The indicia of FIGS. 6a-6d are analogous to the corresponding FIGS. 5a-5d, except that the completed indicia of FIG. 6c form OCR-recognizable text characters. In one sense, this may be thought of as a special case of the missing-link mode using graphic images, as the indicia of FIGS. 6a-6d may be considered graphic images, and the completed indicia of FIG. 6c may be considered a particular kind of graphic image that depict text. It will be seen that none of the indicia of FIGS. 6a, 6b, and 6d is individually recognizable by a human observer, while the completed combination in the indicia of FIG. 6c is readily recognizable by a human observer as the text "Ångstrom." The text "Ångstrom" revealed in the combination shown in the indicia of FIG. 6c is also OCR-recognizable.

The following description of FIGS. 6a-6d is thus entirely analogous to the description above of FIGS. 5a-5d. The indicia of FIG. 6a consist of selected fragments of the indicia of FIG. 6c. The fragments in FIG. 6a may together comprise any desired fraction of the total area of the indicia of FIG. 6c, for example, but these fragments are preferably selected to be approximately half of the indicia area of FIG. 6c. The fragments in FIG. 6a may be selected by a random or pseudo-random process so as to avoid being readily predictable by a counterfeiter. In use of the invention, the indicia of FIG. 6a are printed with ink visible under illumination with visible light. Thus, under illumination with visible light alone, only the unrecognizable indicia of FIG. 6a are seen by a human observer. Indicia corresponding to either FIG. 6b or FIG. 6d are printed with ink visible only under illumination with non-visible light, e.g. fluorescent ink. The selection of indicia of FIG. 6b or FIG. 6d is again determined by relative contrast considerations and/or by a tradeoff with complexity of the authentication system, as explained above. For understanding of the missing-link method, it is sufficient at this point to consider the indicia of FIG. 6b and their relationships with those of FIG. 6a. The indicia of FIG. 6b are printed with ink visible only under illumination with non-visible light, e.g. with fluorescent ink, and are printed in registration with the indicia of FIG. 6a, i.e. aligned with the indicia of FIG. 6a to within a predetermined precision. Like the indicia of FIG. 6a, the indicia of FIG. 6b consist of selected fragments of the indicia of FIG. 6c, but those fragments in the indicia of FIG. 6b are generally the fragments missing from the indicia of FIG. 6a. Thus, the indicia of FIG. 6b provide the missing link (missing from the visible indicia of FIG. 6a) needed to form the complete recognizable indicia of FIG. 6c.

As in FIG. 6a, the fragments in the indicia of FIG. 6b taken together may also comprise any desired fraction of the image area of the indicia of FIG. 6c that is at least the complement of the fractional portion represented by FIG. 6a, but the fragments are also preferably selected to be approximately half of the indicia area of the indicia of FIG. 6c. Again, as in the case of FIGS. 5a-5d, there may be some overlap in the two portions if desired, and that overlap portion may be selected by a random or pseudo-random process so as to avoid being readily predictable by a counterfeiter.

FIG. 6d illustrates an alternative to FIG. 6b, taking into account the relative contrast of the inks used and the common background. In some situations it may be necessary to use indicia like the indicia of FIG. 6d instead of indicia like those of FIG. 6b, because in use, the indicia of FIG. 6a are printed with ink darker than the background, while the ink visible only under illumination with non-visible light, e.g. fluorescent ink, is brighter than the same common

background. The indicia of FIG. 6d differ from the indicia of FIG. 6b essentially in having reversed contrast. Such reversed-contrast printing is not necessary, however if human recognition of the completed image such as the indicia of FIG. 6c is not required, as the logic of the authentication system hardware or software can include a logical inversion of the contrast obtained with illumination with non-visible light, as discussed above with respect to FIGS. 5a-5d.

FIGS. 7a-7d illustrate example indicia used in the authentication system for barcode recognition in accordance with the present invention. Generally, the descriptions above of the relationships among FIGS. 5a-5d and among FIGS. 6a-6d apply analogously to FIGS. 7a-7d. Thus, FIG. 7c is a complete and valid barcode that is recognizable by image comparison or by OCR. FIG. 7d is the negative of FIG. 7b, presented as an alternative to FIG. 7b, for taking into account the relative contrast of the inks used and the common background. However, FIGS. 7a-7d also illustrate a further useful feature of the invention. One way of describing this feature is by noting that the separation into two incomplete images has been made only along one dimension, perpendicular to the bars. In other words, each bar of FIGS. 7a and 7b is a selected portion of a selected bar of FIG. 7c, formed by dividing the selected barcode bars lengthwise. Each of FIGS. 7a, 7b, and 7d has the general appearance of a barcode, but the indicia of these three figures are not valid barcodes. Scanning of any of FIGS. 7a, 7b, or 7d with a conventional barcode scanner would fail to produce a valid scan (i.e., readout of a valid code). Only FIG. 7c, which consists of a combination of FIGS. 7a and 7b by registered superposition of the two, is a complete, valid barcode, which in fact, decodes as the word "Ångstrom."

The printing of image or character portions may be done by using a color printer such as a color laser printer or color inkjet printer. (Monochrome or "black-and-white" types of printers may be used with multiple passes for the various inks, with some added inconvenience.) The image or character portions that are to be visible under non-visible illumination are printed with toner (in the case of a color laser printer) or inkjet ink (in the case of an inkjet printer) containing suitable substances such as fluorescent substances described above. Such methods are described in the U.S. Pat No. 5,714,291 to Marinello et al., mentioned above and incorporated herein by reference.

It will be recognized that the novel "missing-link" method of the present invention may be applied to any of the standard barcode symbologies, including linear codes (e.g., UPC-A, UCC/EAN-14, or UCC/EAN-128) or two-dimensional symbologies (e.g., those known as PDF417, Data Matrix, MaxiCode, or QR Code), or to composite barcodes (e.g., RSS-14 Stacked or RSS-14 Limited), or to any other barcode symbologies that may be developed in the future. As is known in the art, various barcode symbologies, when valid, can be recognized by image comparison, by OCR methods, or by other techniques.

Of course, the completed characters in the indicia formed by the combination of incomplete indicia can spell messages, such as security-related messages that are more extensive than a single word. An example of such a security-related message is "A genuine article will show this message and an image of the Statue of Liberty." Thus, the missing-link mode of operation may include the use of either graphic images or OCR-recognizable text or some combination of graphic images and OCR-recognizable text. For some applications using a combination of graphic images and text, it is preferable that the text and graphic image be related to each

other. For example, the text may explicitly refer to a graphic image, as in the security message example above. In addition, a graphic image formed using the missing-link mode of operation may be used to point to the text, surround the text, or otherwise call attention to the text for the benefit of the user.

While the examples of images and OCR-recognizable characters shown in the drawings and described in the accompanying descriptions are binary (nominally “black and white,” encoded with two bits) for simplicity and clarity of the description, those skilled in the art will recognize that either the images or OCR characters and both the visible and fluorescent sub-portions of each may be gray-scale images encoded with more than two bits.

Either the visible sub-image or the fluorescent sub-image or the combination image may further contain steganographic or so-called “digital watermark” information encoded and inserted in accordance with any of several methods known in the art (e.g., methods as disclosed in U.S. Pat. Nos. 5,710,834; 5,745,569; 5,745,604; 5,748,763; 5,748,783; 5,768,426; 5,822,432; 5,822,436; 5,832,119; 5,841,886; 5,841,978; 5,850,481; 5,862,260; and 5,889,868, the entire disclosure of each of which is inserted herein by reference). Those skilled in the art will recognize that the steganographic or digital watermark information may similarly be encoded and inserted into the visible and/or fluorescent sub-portions and/or the recombined OCR characters such as those of FIGS. 6a–6d.

Other embodiments of the invention will be apparent to those skilled in the art from a consideration of this specification or from practice of the invention disclosed herein. For example, while FIGS. 1, 2 and 3 show a beam splitter 30 separating illuminating optical path portion 15 from return optical path portion 16, these portions may be separated instead by an opaque wall or septum which may be an integral part of housing 200, or one or both optical path portions may be confined to separate optical fibers. If it is required to bend illuminating optical path portion 15 and/or return optical path portion 16, that optical path may be bent by other conventional means such as mirrors, prisms, optical fibers, or light pipes. Various optical components shown in the drawings may be rearranged while still performing substantially the same functions. For example focusing optical element 35 may be a mirror or holographic optical element instead of the conventional lens illustrated in FIG. 2. Also, optical element 35 may be re-positioned to operate on both illuminating portion 15 and return portion 16 of the optical path.

While uses of the authentication system and methods have been described in terms of authentication, it will be clear that the same apparatus and methods may be useful for applications other than authentication, such as mail sorting, quality control of articles during their manufacture, or identification of articles during shipping, repair, or cleaning, etc. It is intended that the specification and examples be considered as exemplary only, with the true scope and spirit of the invention being defined by the following claims.

Having described my invention, I claim:

1. A method of authenticating articles, comprising the steps of:
 - a) selecting a set of indicia recognizable by automatic optical character recognition;
 - b) providing articles of which authentic instances are known to have been identified with said selected indicia such that each of said selected indicia comprises two portions in complementary pair relationship, neither of

said two portions by itself forming a complete recognizable character:

- (i) a first portion comprising first detail elements that emit fluorescent light in predetermined portions of the optical spectrum when illuminated by light outside of the visible spectrum, and
 - (ii) a second portion comprising second detail elements complementary to said first detail elements, said first and second portions being overlaid relative to each other so as to complete said selected indicia;
- c) illuminating said articles with said light outside of the visible spectrum while selecting said predetermined portions of the optical spectrum and while performing said automatic optical character recognition; and
 - d) providing an affirmative output if and only if said indicia are recognized, thereby confirming the authenticity of those instances of said articles so identified.
2. The method of claim 1, further comprising the step of:
 - e) before said article-providing step (b), identifying said articles by marking with said selected indicia such that said first detail elements of said first portion are made with fluorescent ink, while said second detail elements of said second portion of said selected indicia are made with a visible ink.
 3. The method of claim 1, wherein said light outside of the visible spectrum comprises ultraviolet light.
 4. The method of claim 1, wherein said light outside of the visible spectrum comprises infrared light.
 5. A method of authenticating articles, comprising the steps of:
 - a) selecting a set of graphic image indicia recognizable by automatic image matching;
 - b) providing articles of which authentic instances are known to have been identified with said selected graphic image indicia such that each of said selected graphic image indicia comprises two portions in complementary pair relationship, neither of said two portions by itself forming a complete recognizable image:
 - (i) a first portion comprising first detail elements that emit fluorescent light in predetermined portions of the optical spectrum when illuminated by light outside of the visible spectrum, and
 - (ii) a second portion comprising second detail elements complementary to said first detail elements, said first and second portions being overlaid relative to each other so as to complete said selected graphic image indicia;
 - c) illuminating said articles with said light outside of the visible spectrum while selecting said predetermined portions of the optical spectrum and while performing said automatic image matching; and
 - d) providing an affirmative output if and only if said graphic image indicia are recognized, thereby confirming the authenticity of those instances of said articles so identified.
 6. The method of claim 5, further comprising the step of:
 - e) before said article-providing step (b), identifying said articles by marking with said selected graphic image indicia such that said first detail elements of said first portion are made with fluorescent ink, while said second detail elements of said second portion of said selected graphic image indicia are made with a visible ink.

7. An authenticatable document for identification or for use in financial transactions, comprising:

- a) a substrate suitable for printing with fluorescent ink, and
- b) selected indicia,

selected portions of said selected indicia being printed on said document with fluorescent ink containing predetermined concentrations of one or more fluorescent substances, both said selected indicia and said fluorescent substances encoding predetermined characteristics of said authenticatable document, said selected indicia being selected from predetermined sets of:

- (i) characters readable by automatic optical character recognition only when said selected portions of said selected indicia are illuminated with ultraviolet light, and
- (ii) graphic images recognizable by automatic image comparison only when said selected portions of said selected indicia are illuminated with ultraviolet light,

said selected indicia being further characterized in that each of said selected indicia comprises two portions in complementary pair relationship, neither of said two portions by itself forming a complete recognizable character or image:

- (A) a first portion comprising first detail elements that emit fluorescent light in predetermined portions of the optical spectrum when illuminated with said ultraviolet light, and
- (B) a second portion comprising second detail elements complementary to said first detail elements, said first and second portions being overlaid relative to each other so as to complete said selected indicia.

8. An authenticatable document as in claim 7, wherein said substrate is a material selected from the list consisting of paper, cardboard, fabric, plastic, ceramic, metal, and glass.

9. An authenticatable document as in claim 8, wherein said paper is selected from the list consisting of rag paper, linen paper, mixed pulp and rag paper, recycled paper, vellum, synthetic paper, currency paper, security paper, and tamper-resistant paper.

10. An authenticatable document as in claim 7, wherein said substrate is a plastic card.

11. An authenticatable document as in claim 7, wherein said selected indicia are printed in registration with selected second indicia printed on said substrate.

12. An authenticatable document as in claim 11, wherein said selected indicia are printed in registration with selected second indicia, said second indicia being identical indicia printed on said substrate with ink visible under illumination within the visible spectrum.

13. An authenticatable document as in claim 7, wherein said selected indicia are printed in predetermined offset from registration with images or characters printed with visible substances.

14. An authenticatable document as in claim 7, wherein said ink visible only under illumination with light outside of the visible spectrum comprises predetermined concentrations of one or more fluorescent substances, and said selected indicia are printed in predetermined offset from registration with images or characters printed with fluorescent substances of different characteristic fluorescent wavelength from said selected indicia.

15. An authenticatable document as in claim 13, wherein said selected indicia and said images or characters previ-

ously printed each forms an incomplete image, and their combination forms a single image recognizable by said automatic image comparison.

16. An authenticatable document as in claim 15, wherein said selected indicia comprise barcodes.

17. An authenticatable document as in claim 16, wherein said selected portions of said selected indicia are formed by dividing individual bars of said barcodes lengthwise.

18. An authenticatable document as in claim 14, wherein said selected indicia and said images or characters previously printed with fluorescent substances of different characteristic fluorescent wavelength from said selected indicia each forms an incomplete image, and their combination forms a single image recognizable by said automatic image comparison.

19. An authenticatable document as in claim 18, wherein said selected indicia comprise barcodes.

20. An authenticatable document as in claim 19, wherein said selected portions of said selected indicia are formed by dividing individual bars of said barcodes lengthwise.

21. An authenticatable document as in claim 7, wherein said selected indicia include steganographically encoded information.

22. An authenticatable document as in claim 7, wherein said images or characters include steganographically encoded information.

23. An authenticatable document for identification or for use in financial transactions, comprising:

- a) a substrate suitable for printing with fluorescent ink, and

b) selected indicia, selected portions of said selected indicia being printed on said document with fluorescent ink containing predetermined concentrations of one or more fluorescent substances, both said selected indicia and said fluorescent substances encoding predetermined characteristics of said authenticatable document, said selected indicia being selected from predetermined sets of characters readable by automatic optical character recognition only when said selected portions of said selected indicia are illuminated with ultraviolet light

said selected indicia being further characterized in that each of said selected indicia comprises two portions in complementary pair relationship, neither of said two portions by itself forming a complete recognizable character:

- (A) a first portion comprising first detail elements that emit fluorescent light in predetermined portions of the optical spectrum when illuminated with said ultraviolet light, and
- (B) a second portion comprising second detail elements complementary to said first detail elements, said first and second portions being overlaid relative to each other so as to complete said selected indicia.

24. An authenticatable document as in claim 23, wherein said predetermined characteristics of said authenticatable document are encoded steganographically.

25. An authenticatable document for identification or for use in financial transactions, comprising:

- a) a substrate suitable for printing with fluorescent ink, and

b) selected indicia, selected portions of said selected indicia being printed on said document with fluorescent ink containing predetermined concentrations of one or more fluorescent substances, both said selected indicia and said fluorescent substances encoding predeter-

mined characteristics of said authenticatable document, said selected indicia being selected from predetermined sets of graphic images recognizable by automatic image comparison only when said selected portions of said selected indicia are illuminated with ultraviolet light, said selected indicia being further characterized in that each of said selected indicia comprises two portions in complementary pair relationship, neither of said two portions by itself forming a complete recognizable image:

(A) a first portion comprising first detail elements that emit fluorescent light in predetermined portions of the optical spectrum when illuminated with said ultraviolet light, and

(B) a second portion comprising second detail elements complementary to said first detail elements, said first and second portions being overlaid relative to each other so as to complete said selected indicia.

26. An authenticatable document for identification or for use in financial transactions, comprising:

- a) a substrate suitable for printing with ink visible only under illumination with light outside of the visible spectrum, and
- b) selected indicia, selected portions of said selected indicia being printed on said document with said ink

visible only under illumination with light outside of the visible spectrum, said selected indicia being further characterized in that each of said selected indicia comprises two portions in complementary pair relationship, neither of said two portions by itself forming a complete recognizable image:

(A) a first portion comprising first detail elements that emit fluorescent light in predetermined portions of the optical spectrum when illuminated with said light outside of the visible spectrum, and

(B) a second portion comprising second detail elements complementary to said first detail elements, said first and second portions being overlaid relative to each other so as to complete said selected indicia, and

both said selected indicia and said ink encoding predetermined characteristics of said authenticatable document,

said selected indicia being selected from predetermined sets of characters readable by automatic optical character recognition only when said selected portions of said selected indicia are illuminated with light outside of the visible spectrum.

* * * * *