



US006370834B1

(12) **United States Patent**  
**Nickell et al.**

(10) **Patent No.:** **US 6,370,834 B1**  
(45) **Date of Patent:** **Apr. 16, 2002**

(54) **INSECT CONTROL FOR BUILDINGS**

5,860,266 A \* 1/1999 Martinet et al. .... 52/741.3  
6,083,519 A \* 7/2000 Jeannin ..... 424/411  
6,156,328 A \* 12/2000 Alcott et al. .... 424/405

(75) Inventors: **Craig A. Nickell**, Sherman; **Cynthia B. Finley**, Dallas; **Norwin C. Derby**, West Tawakoni, all of TX (US)

\* cited by examiner

(73) Assignee: **Super Sack Mfg. Corp.**, Dallas, TX (US)

*Primary Examiner*—Carl D. Friedman

*Assistant Examiner*—Steve Varner

(\* ) Notice: Subject to any disclaimer, the term of this patent is extended or adjusted under 35 U.S.C. 154(b) by 0 days.

(74) *Attorney, Agent, or Firm*—Michael A. O’Neil

(57) **ABSTRACT**

(21) Appl. No.: **09/478,907**

The intrusion of insects into a home or similar building is controlled by utilizing insect controlling plastic materials in the construction of the building. The insect controlling plastic building materials are manufactured by first blending one or more plastic resins with one or more insect controlling chemical agents to form a blended plastic resin/insect controlling chemical agent material. The blended plastic resin/insect controlling chemical agent material is then utilized to manufacture plastic films, sheets, non-woven fabrics, woven fabrics, insulating foams, flooring materials, wall covering materials, and the like utilizing conventional manufacturing techniques.

(22) Filed: **Jan. 7, 2000**

(51) **Int. Cl.**<sup>7</sup> ..... **E04B 1/00**

(52) **U.S. Cl.** ..... **52/741.3**; 43/121; 424/411; 424/405

(58) **Field of Search** ..... 52/101, 741.3; 43/124, 132.1

(56) **References Cited**

**U.S. PATENT DOCUMENTS**

5,392,559 A \* 2/1995 Long ..... 43/121

**1 Claim, 5 Drawing Sheets**

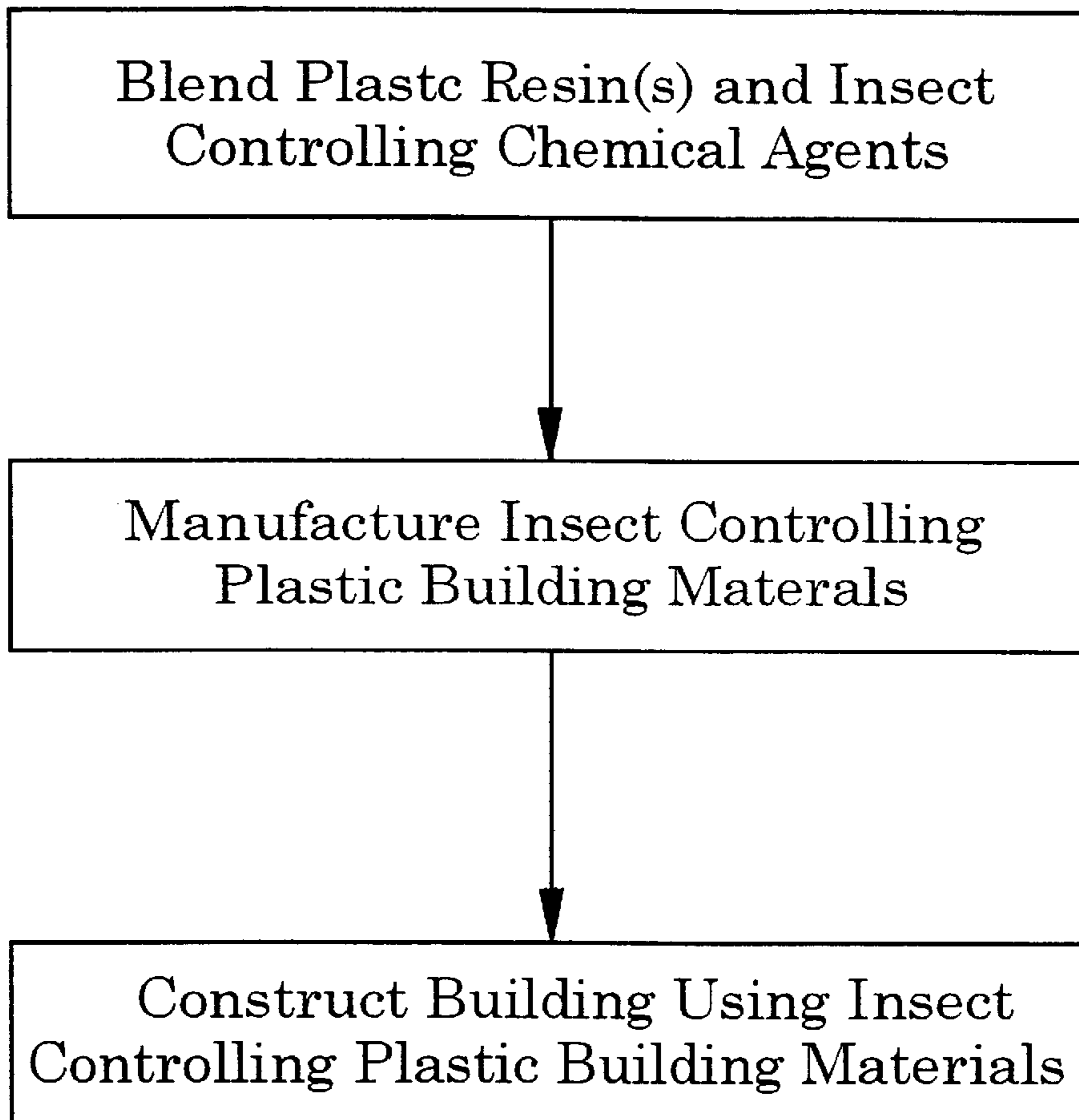

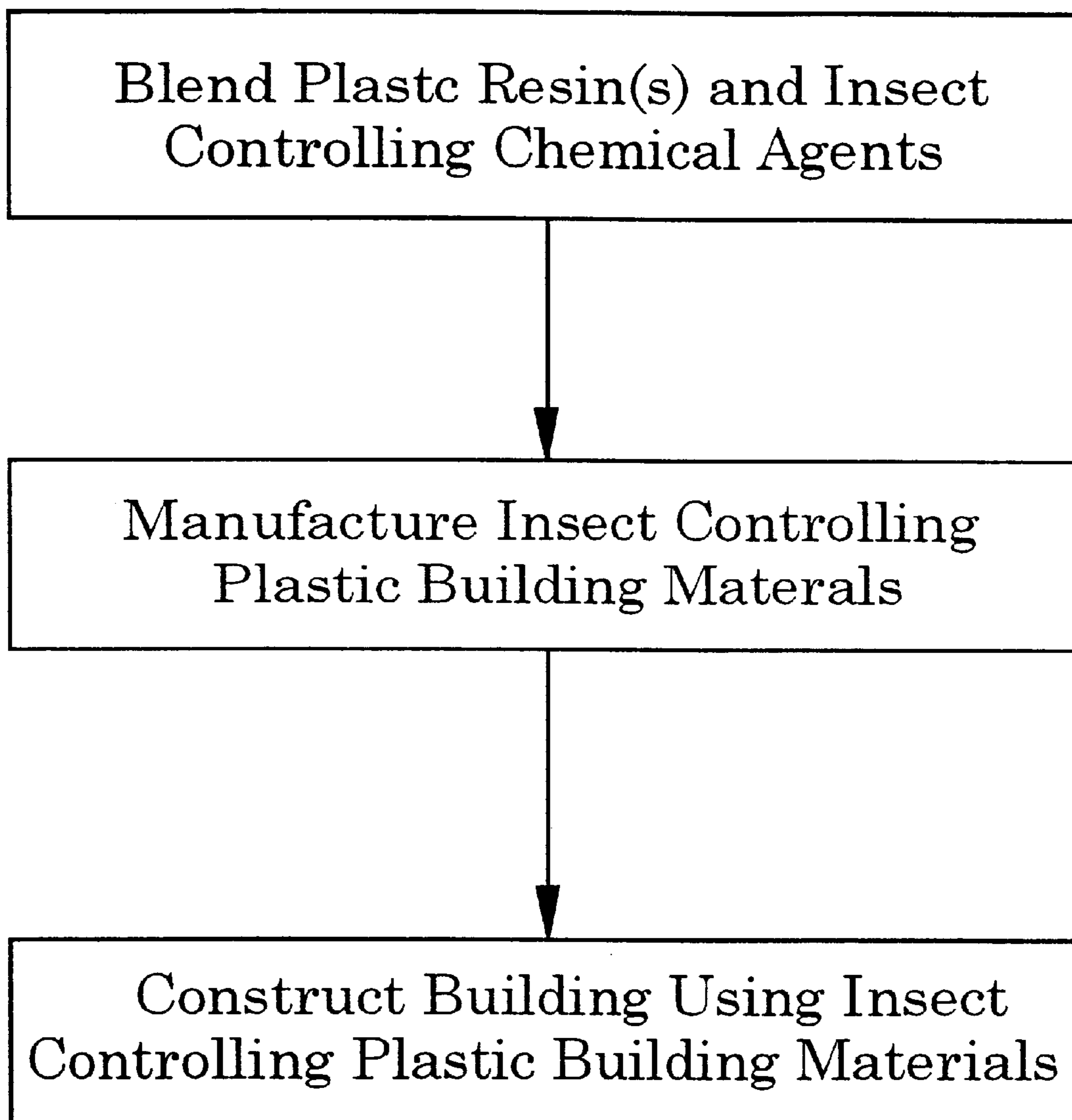

*Fig. 1*

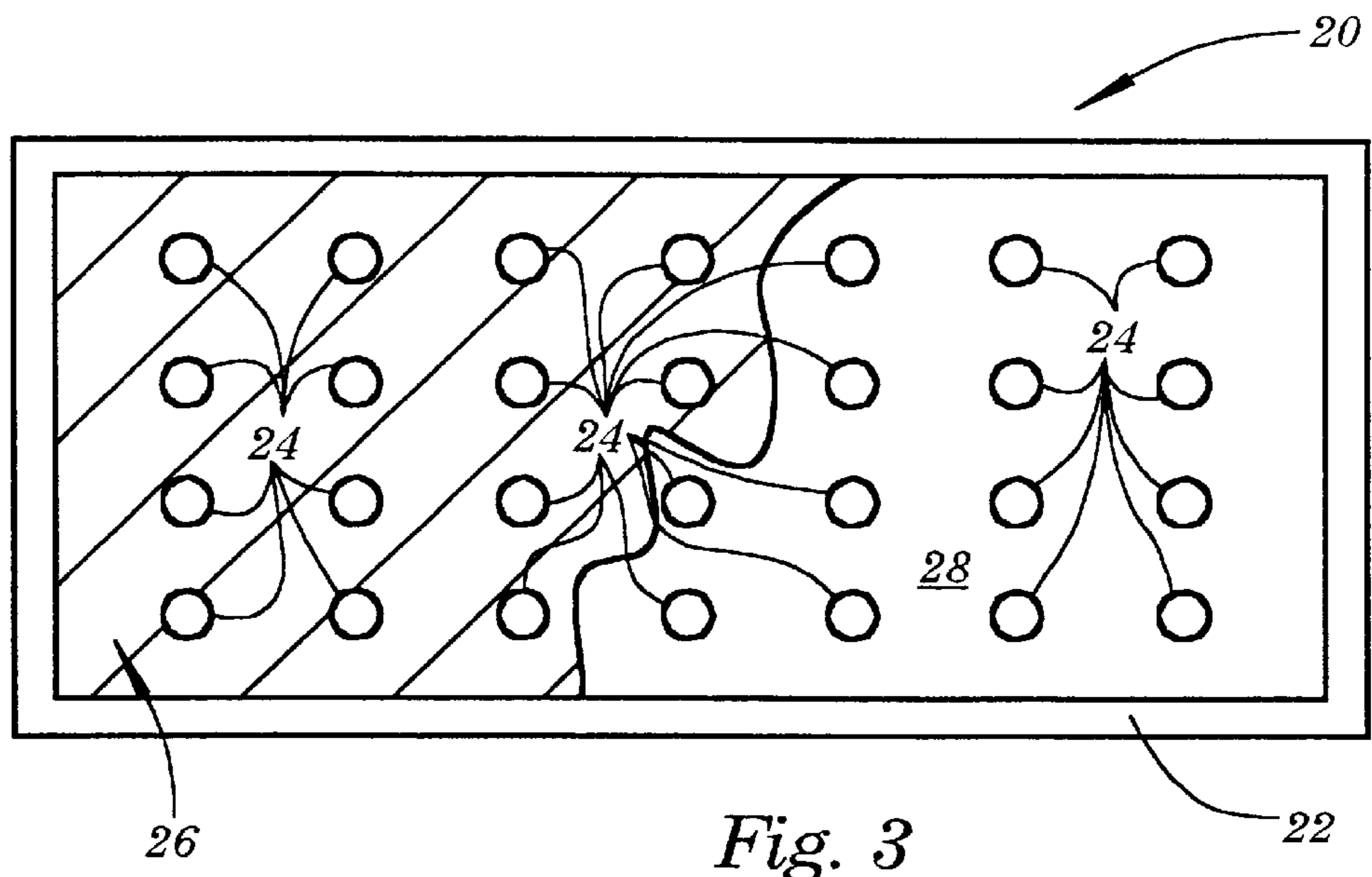
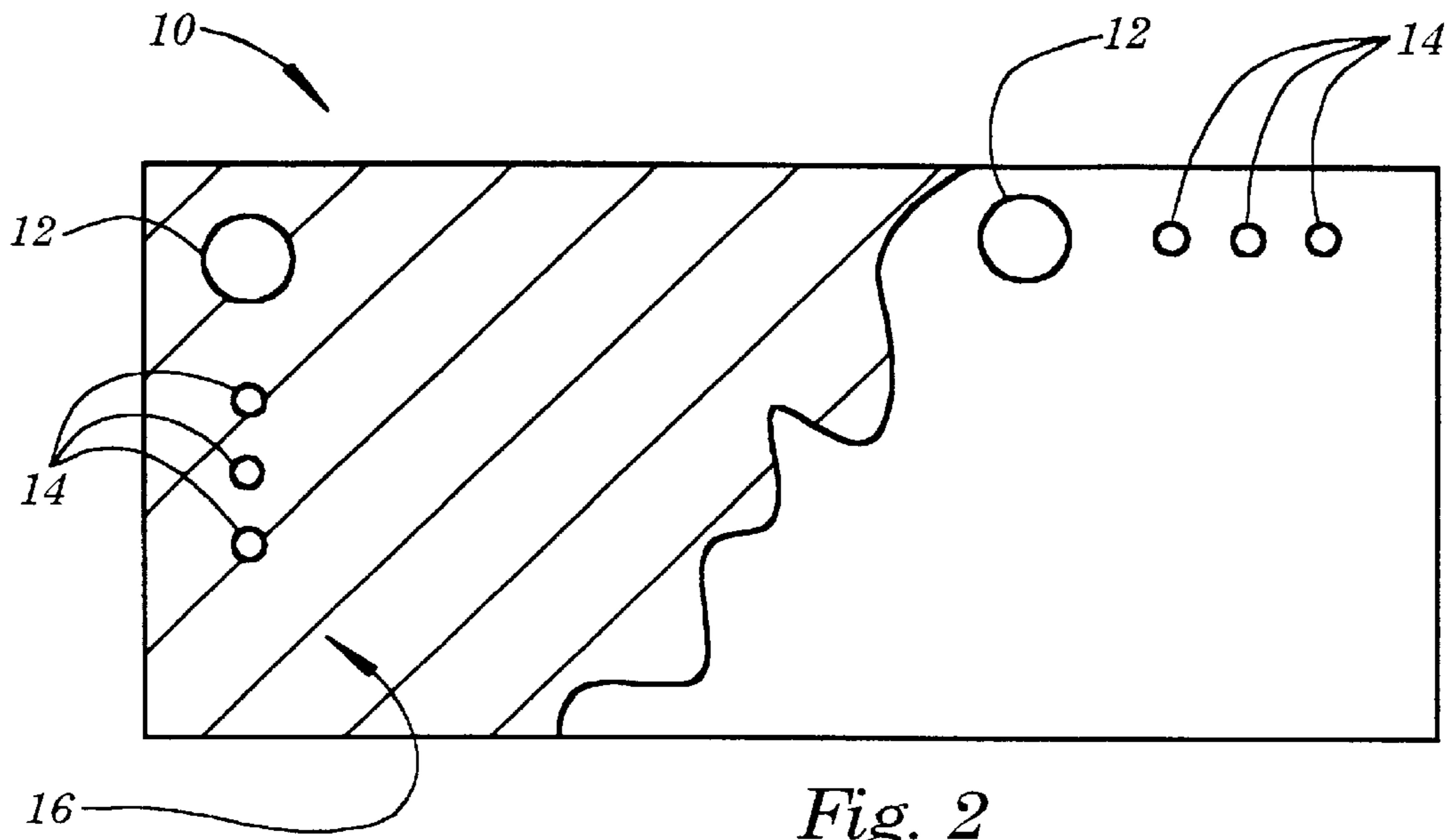

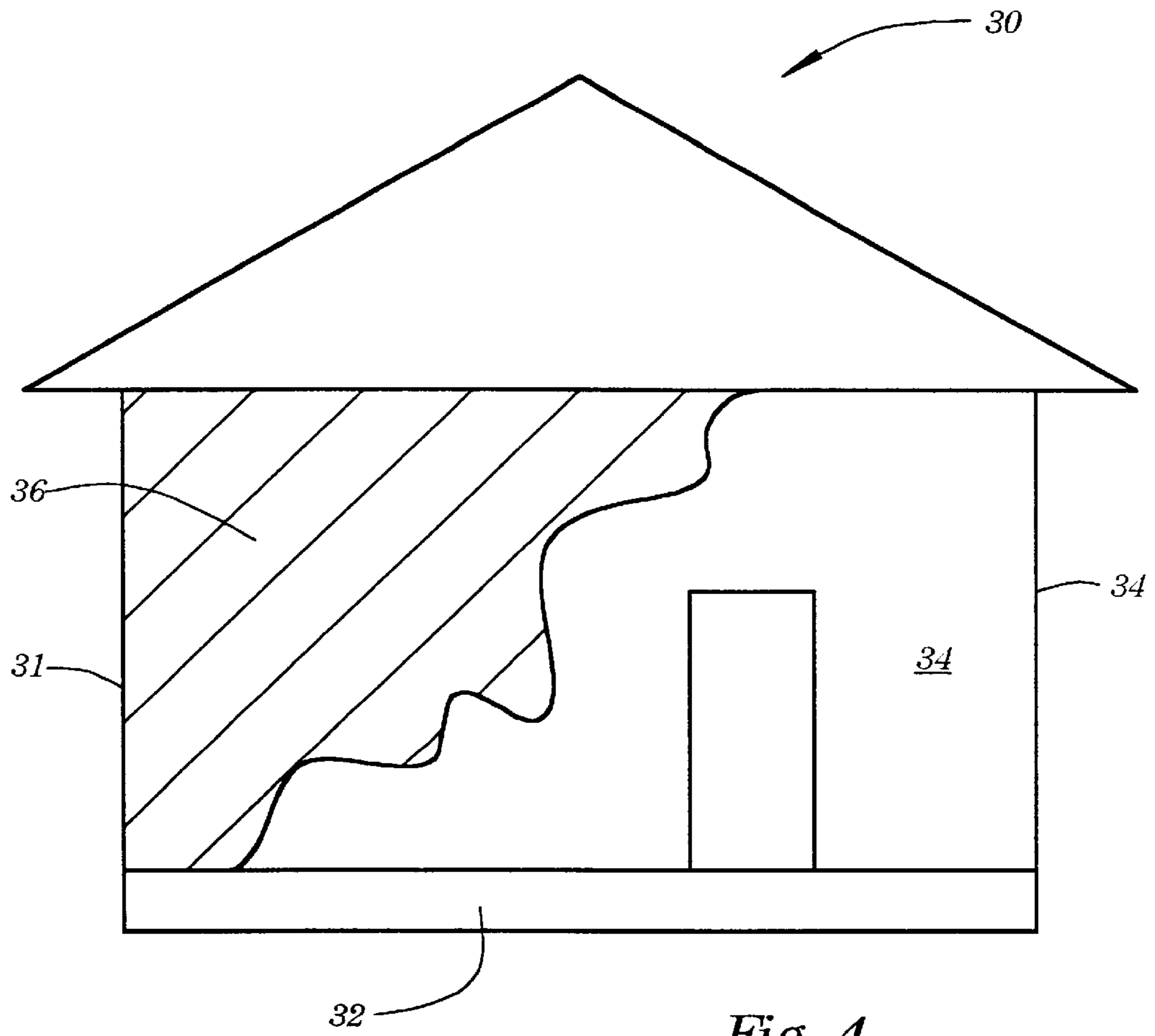
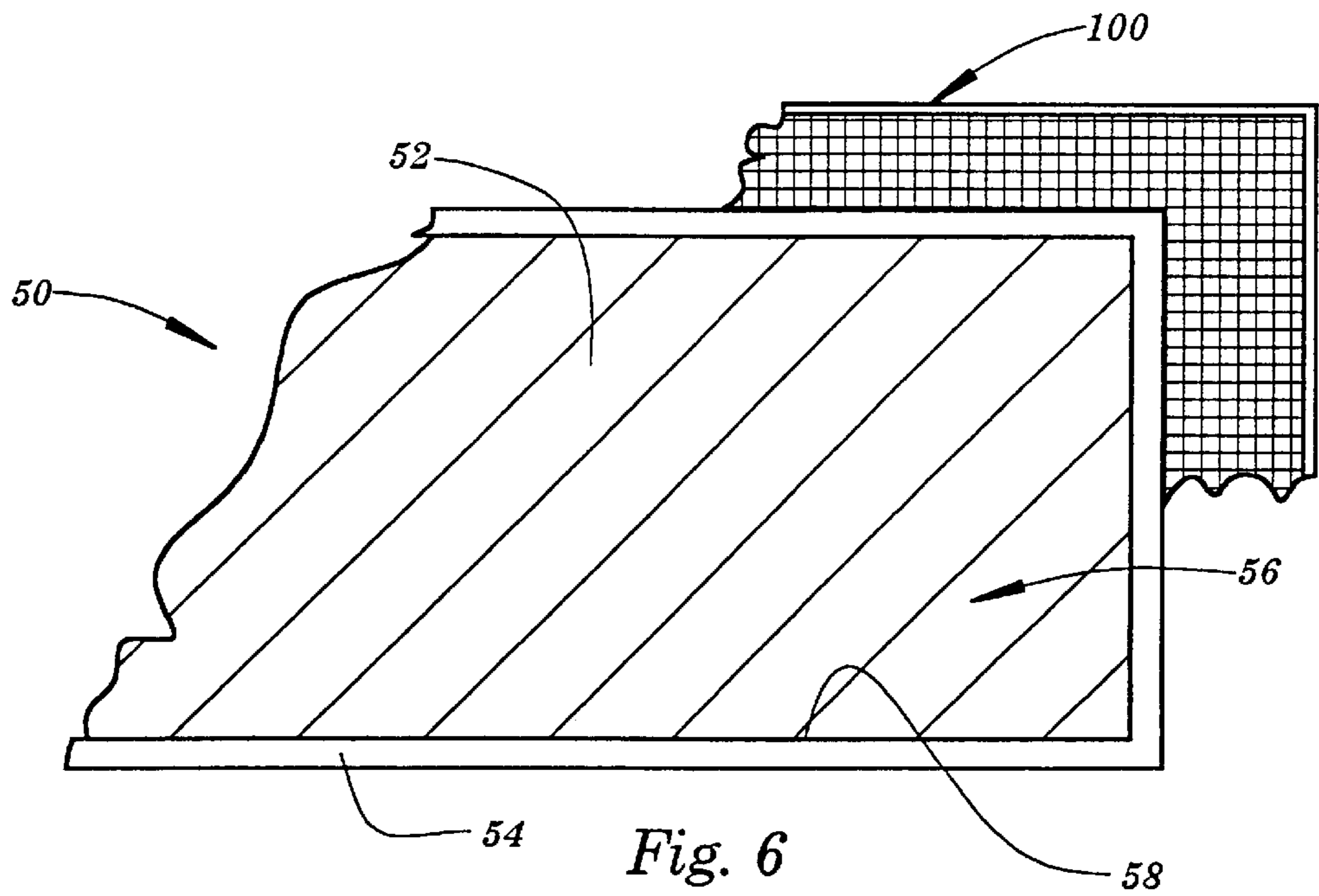
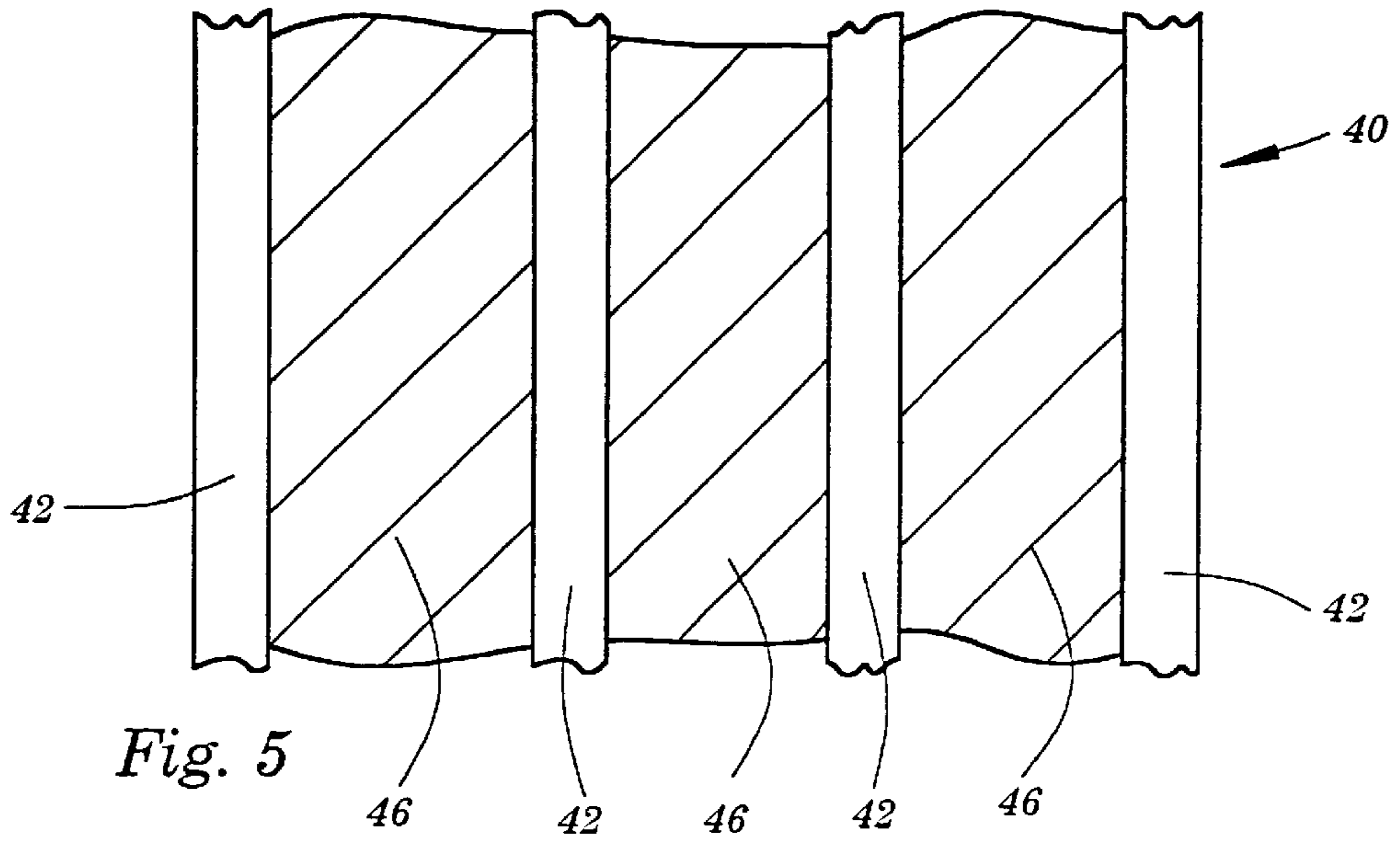

Fig. 4



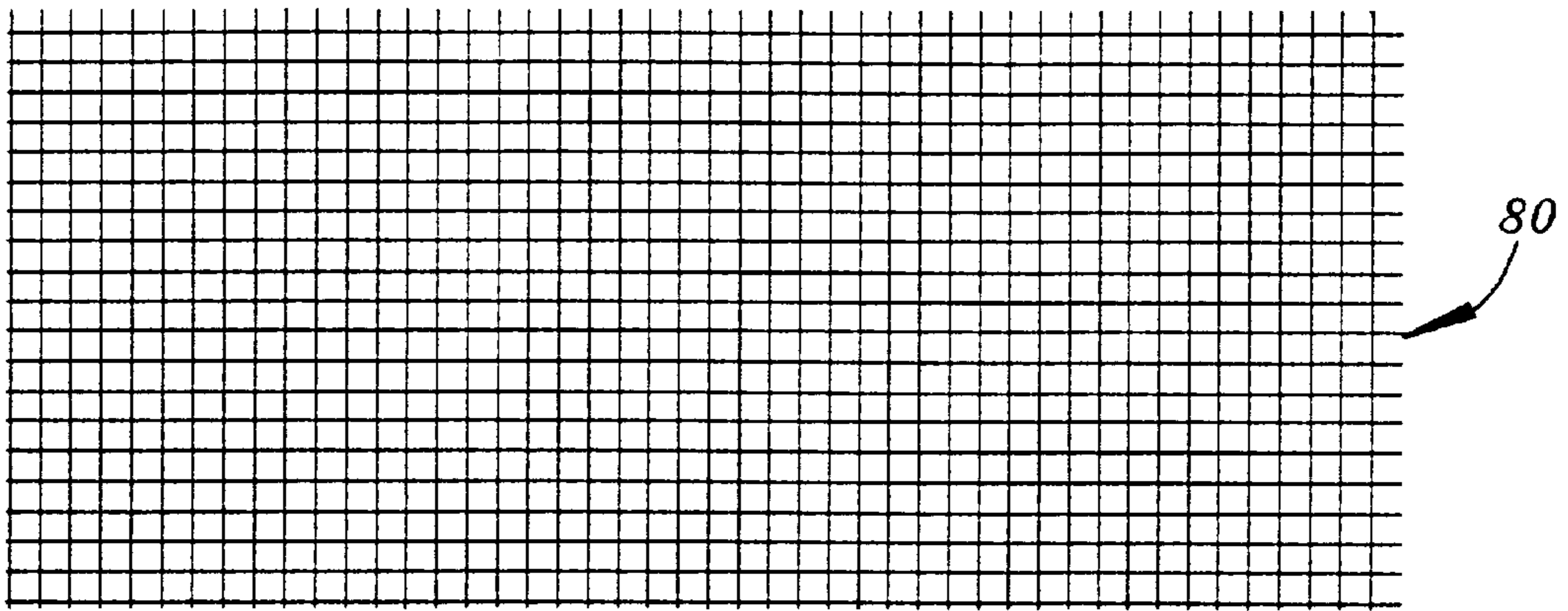
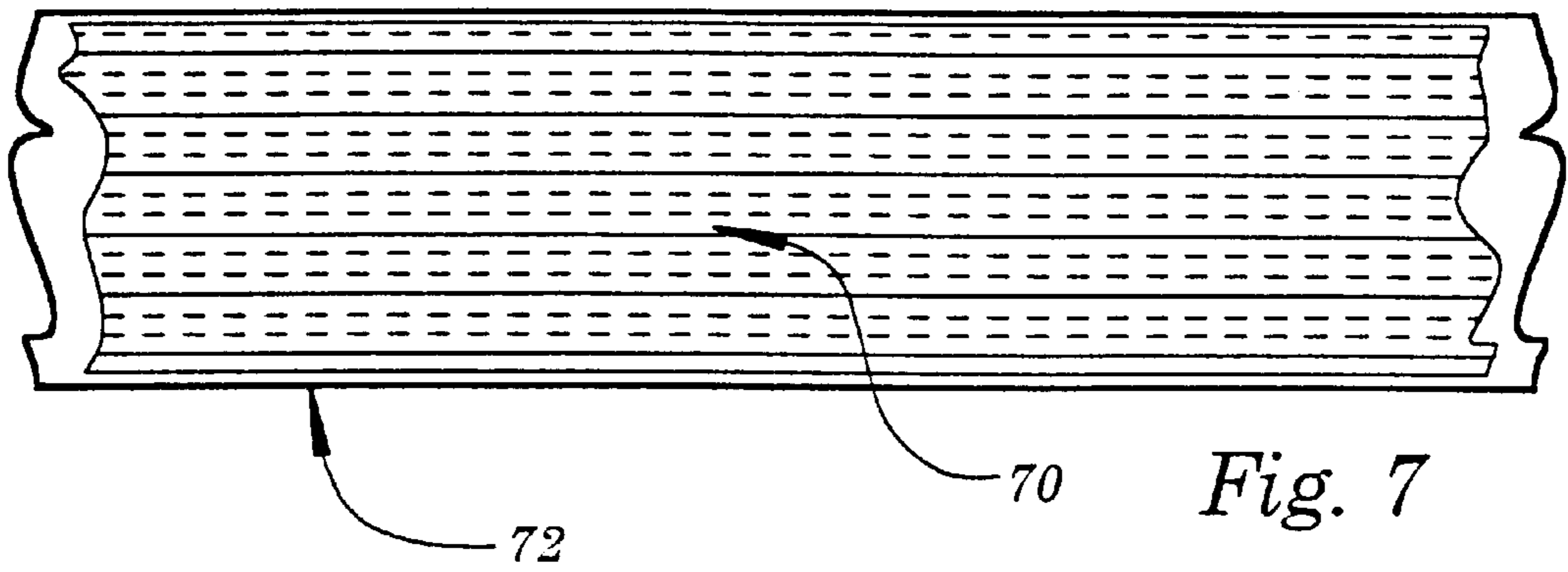
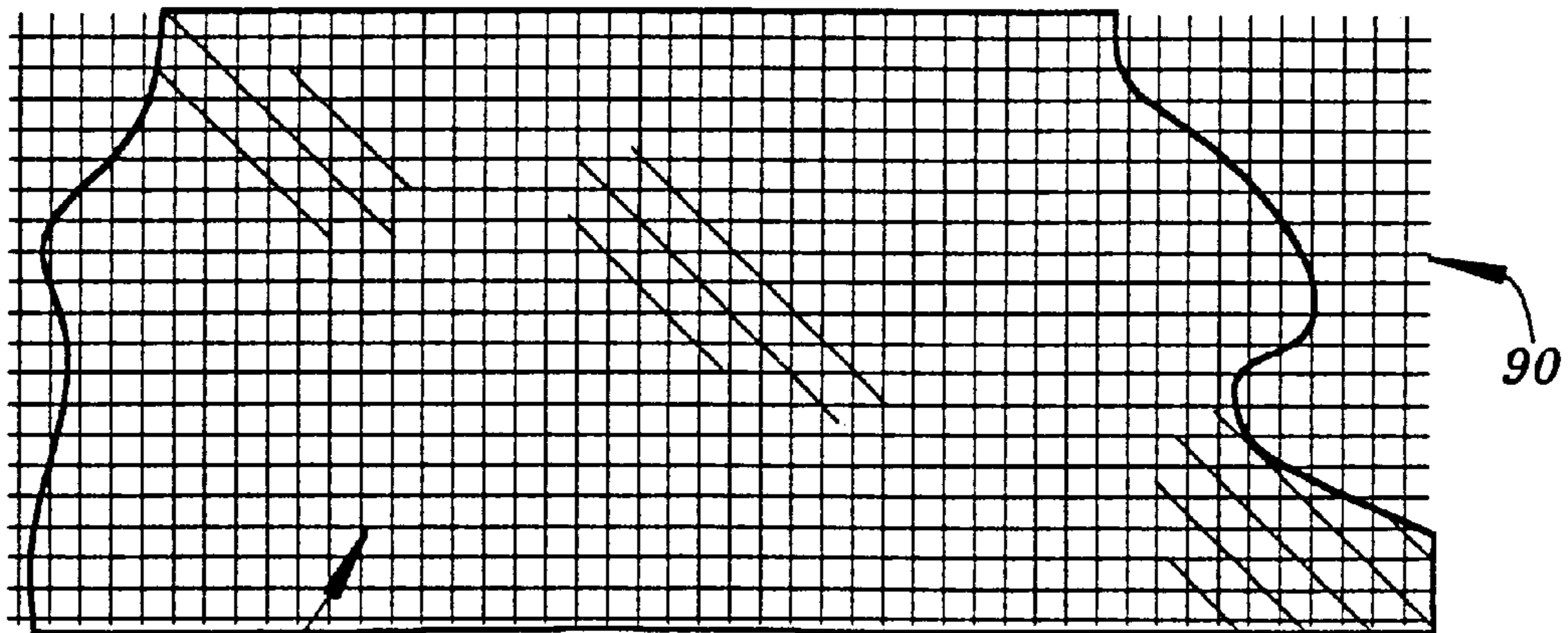

Fig. 8



92

Fig. 9

90

## INSECT CONTROL FOR BUILDINGS

## TECHNICAL FIELD

The present invention relates generally to the prevention of damage and other problems caused by the presence of various insects in and around buildings, and more particularly to plastic materials having one or more chemical agents contained therein which are adapted for applications in and around buildings to prevent insect-related problems.

## BACKGROUND AND SUMMARY OF THE INVENTION

As is well known, termites, carpenter ants, and other wood eating insects annually cause hundreds of millions of dollars in damage to homes and similar buildings. Fleas and ticks similarly cause injury to pets, working animals such as hunting dogs, livestock, and humans. Insects such as roaches and houseflies, while not causing direct damage, are considered to be disease carriers. For these and other reasons the total exclusion of insects from residences and similar buildings is considered to be highly desirable.

Heretofore insect control has generally been accomplished by spraying or otherwise applying insecticides and similar chemical agents in and around the building to be protected. Termites and similar insects are sometimes controlled by applying chemical agents beneath the surface of the soil surrounding free standing buildings such as homes, and the like. However, notwithstanding numerous advances in the art of insect control over the years, insects continue to cause substantial problems for owners and occupants of homes and similar buildings. Thus, the need exists for still further improvements in the art.

In accordance with the broader aspects of the present invention, one or more insect controlling chemical agents are incorporated into plastic film, plastic sheeting, non-woven fabrics formed from plastic materials, woven fabrics formed from plastic materials, and other plastic materials. The plastic materials having the insect controlling chemical agents contained therein are then used in the construction and maintenance of homes and similar buildings. For example, plastic material having insect controlling chemical agents contained therein can be utilized as a vapor barrier between the foundation of the building and the structure constructed thereon. Plastic material having insect controlling agents contained therein can also be used as a wrap surrounding the exterior walls of the building. Plastic material having insect controlling agents contained therein can also be used within the interior of the building for applications such as flooring materials, wall coverings, insulation materials, etc. Plastic material having insect controlling agents contained therein may also be deployed around the exterior of the building.

In accordance with more specific aspects of the invention, plastic materials such as polyethylene, polypropylene, polyurethane, polystyrene, etc. are doped with an insect controlling chemical agent such as Fipronil, the chemical formula for which is 5-amino-1-([2,6-dichloro-4-trifluoromethyl) phenyl)-4-[(1R, S) trifluoromethyl sulfinyl]-1H-pyrazole-3-carbonitrile and are thereby rendered insecticidal. Although the insect controlling chemical agent known as Fipronil is preferred, other insect controlling chemical agents may be used in the practice of the invention, if desired. The insect controlling chemical agent is preferably added to the resin which is utilized in the manufacture of plastic building materials prior to the manufacturing steps which are employed to convert the resin into the desired

plastic product. Subsequently, the plastic material having the insect controlling chemical agent contained therein is utilized in the construction and maintenance of homes and similar buildings. When properly employed, the insect controlling plastic materials of the present invention can be successful in totally excluding insects from homes and similar buildings.

## BRIEF DESCRIPTION OF THE DRAWINGS

A more complete understanding of the present invention may be had by reference to the following Detailed Description when taken in connection with the accompanying Drawings wherein:

FIG. 1 is flow chart illustrating the broader aspects of the invention;

FIG. 2 is a diagrammatic illustration of a first application of the invention;

FIG. 3 is a diagrammatic illustration of a second application of the invention;

FIG. 4 is a diagrammatic illustration of a third embodiment of the invention;

FIG. 5 is a diagrammatic illustration of a fourth embodiment of the invention;

FIG. 6 is a diagrammatic illustration of a fifth embodiment of the invention;

FIG. 7 is a diagrammatic illustration of a sixth embodiment of the invention;

FIG. 8 is a diagrammatic illustration of a seventh embodiment of the invention; and

FIG. 9 is a diagrammatic illustration of an eighth embodiment of the invention.

## DETAILED DESCRIPTION

Referring now to the Drawings, and particularly to FIG. 1 thereof, the practice of the present invention begins with the blending of one or more insect controlling chemical agents into one or more plastic resins. The chemical agent or agents are selected from the group of insect controlling chemical agents having an effective life extending over several decades. The amount of the chemical agent or agents to be blended with the plastic resin or resins is likewise selected to prolong the effective life of the combined material in controlling insects. The plastic resin or resins utilized in the practice of the invention are selected from those materials conventionally utilized in building construction, such as polyethylene, polypropylene, polyurethane, polystyrene, etc.

After the selected insect controlling chemical agent or agents and the selected plastic resin or resins have been blended, the blended material is utilized in the manufacture of insect controlling plastic building materials. Preferably, conventional manufacturing techniques are employed in the practice of the invention. For example, the blended plastic resin/insect controlling chemical agent material may be utilized in the manufacture of plastic films by extrusion or other well known film manufacturing techniques. The blended plastic resin/insect controlling chemical agent material may be utilized in the manufacture of non-woven fabrics utilizing well known techniques. Likewise, the blended plastic resin/insect controlling chemical agent material may be utilized in the manufacture of plastic foams utilized in conventional foam manufacturing techniques. The blended plastic resin/insect controlling chemical agent material may be utilized in the manufacture of flooring materials and/or

wall coverings also utilizing well known manufacturing techniques. The blended plastic resin/insect controlling chemical agent material may be used in the manufacture of woven fabrics also using well known manufacturing techniques.

The resulting insect controlling plastic building materials are ultimately utilized in the construction of homes and similar buildings in accordance with well established construction practices. For example, insect controlling plastic film manufactured in accordance with the present invention may be utilized as a moisture barrier between the foundation and the subfloor of a home or similar building or between the underlying earth and the subfloor of a home or similar building depending on the particular construction technique that is utilized. Plastic films and/or non-woven plastic fabrics constructed in accordance with the present invention may be utilized as a wrap surrounding the exterior walls of a home or similar building. Insect controlling plastic foam manufactured in accordance with the present invention may be utilized as insulation in the floors, walls, and/or ceilings of a home or similar building. Insect controlling flooring materials and/or wall coverings may be utilized within the interior of a home or similar building. Insect controlling materials, such as insect controlling woven fabrics may be deployed around the exterior of the building either during construction or as a part of maintenance.

FIGS. 2, 3, 4, 5, 6, 7, 8, and 9 illustrate particular applications of the present invention. Referring particularly to FIG. 2, there is shown a concrete slab 10 of the type commonly utilized in the construction of homes and similar buildings. The slab 10 has conventional large apertures 12 and small apertures 14 formed therein at diverse locations. The apertures 12 and 14 as well as other conventional apertures formed through the slab 10 are utilized to serve as drains from and as plumbing and electrical supplies to the building constructed on the slab 10.

A moisture barrier 16 is positioned over the top surface of the slab 10 prior to the construction of a building thereon. The moisture barrier 16 is manufactured in accordance with the present invention and as such comprises a plastic resin/insect controlling chemical agent blend which is utilized to manufacture the moisture barrier 16 in accordance with conventional moisture barrier manufacturing techniques. For example, the moisture barrier 16 may be manufactured utilizing conventional extrusion techniques. Other manufacturing techniques for manufacturing the moisture barrier 16 will readily suggest themselves to those skilled in the art.

After the moisture barrier 16 is installed on the slab 10 the remainder of the building comprising a home or other similar building is constructed thereon. As is well known, insects such as termites, carpenter ants, and other insects frequently enter a home or similar building through cracks or spaces which exist between the foundation slab and the building constructed thereon. In the practice of the present invention such problem is eliminated because insects entering the space between the slab 10 and building constructed thereon are killed by contact with the moisture barrier 16 having one or more insect controlling chemical agents therein.

Referring to FIG. 3, there is shown a pier and beam-type foundation 20 of the type commonly utilized in the construction of homes and similar buildings. The pier and beam foundation comprises a perimeter wall 22 and a plurality of piers 24 which are typically, but not necessarily exclusively located within the boundary defined by the perimeter wall. The foundation 20 is provided with a moisture barrier 26 constructed in accordance with the present invention which is located between the underlying earth 28 and the subfloor of the building to be constructed on the foundation 20.

The moisture barrier 26 preferably comprises a layer of plastic film having one or more insect controlling chemical

agents contained therein. The moisture barrier 26 is manufactured from a blend of one or more plastic resins and one or more insect controlling agents. The blended plastic resin/insect controlling chemical agent material is formed into a plastic sheet comprising the moisture barrier 26 utilizing conventional manufacturing techniques. For example, the moisture barrier 26 may be manufactured utilizing conventional extrusion techniques or other conventional techniques well known in the industry for manufacturing plastic films and sheets.

Referring to FIG. 4, there is shown a home or similar building 30 which has been constructed in accordance with conventional home building techniques. The building 30 includes a foundation 32 which may be provided with a moisture barrier of the type illustrated in FIG. 1 or FIG. 2 and described hereandabove in conjunction therewith. The building 30 further comprises a plurality of walls 34. The walls 34 are provided with a wrap 36 manufactured in accordance with the present invention.

The wrap 36 comprises plastic film or sheeting having one or more insect controlling chemical agents contained therein. Preferably, the wrap 36 is manufactured from a blend of one or more plastic resins and one or more insect controlling chemical agents. The blended plastic resins/insect controlling chemical agent material is formed into plastic sheeting utilized in techniques commonly employed in such manufacture.

For example, the plastic film or sheeting comprising the wrap 36 may be manufactured utilizing conventional extrusion techniques. The wrap 36 may also comprise a non-woven fabric having one or more insect controlling chemical agents contained therein, in which case the wrap 36 is manufactured utilizing techniques conventionally employed in the manufacture of plastic non-woven fabrics. More specifically, the wrap 36 may be of the type sold by Dupont under the trademark "TYVEK"® which is modified to include one or more insect controlling chemical agents. The wrap 36 may also comprise the non-woven material sold by Reemay under the mark "TYPAR" which is modified to include one or more insect controlling chemical agents.

As is well known, insects often enter a house or similar building through cracks and apertures formed in the walls thereof. When the wrap 36 of the present invention is employed, insects gaining access to the house or building 30 through the walls thereof immediately engage the wrap 36, whereupon such insects are killed. Thus, the wrap 36 is useful in preventing insects from entering the house or building 30.

Referring to FIG. 5, there is shown a construction 40 comprising the wall, ceiling, or floor of the type utilized in the construction of homes and similar buildings. The construction 40 includes a plurality of structural members 42 comprising wall studs, ceiling joists, floor joists, etc. Between the structural members 42 there is provided sections of plastic foam insulation 46 constructed in accordance with the present invention.

The plastic foam insulation is preferably manufactured utilizing a blend of one or more plastic resins and one or more insect controlling chemical agents. The blended plastic resin/insect controlling chemical agent material is manufactured into plastic foam utilizing conventional plastic foam manufacturing techniques. Other plastic insulation manufacturing techniques may be utilized in the practice of the present invention, if desired.

As is well known, insects often gain access to the interior of a home or similar building through the walls, ceiling, or floor thereof. When the present invention is employed, insects attempting to enter a home or similar building through the walls, ceiling, or floor thereof immediately



engage the plastic insulating material **46**, whereupon such insects are immediately killed.

Referring to FIG. **6**, there is shown a section **50** comprising part of the interior of a home or similar building. The construction **50** includes a plurality of walls **52** and a floor **54**, all of which are constructed in accordance with conventional building techniques. The walls **52** of the section **50** may be provided with a wall covering **56** manufactured in accordance with the present invention. Likewise, the floor **54** may be provided with a floor covering **58** manufactured in accordance with the present invention.

The wall covering **56** is preferably manufactured utilizing a blend of one or more plastic resins and one or more insect controlling chemical agents. The blended plastic resin/insect controlling chemical agent material is manufactured into wall covering utilizing conventional wall covering manufacturing techniques. Likewise, the blended plastic resin/insect controlling chemical agent material is manufactured into floor covering utilizing conventional floor covering manufacturing techniques.

Referring to FIG. **7**, there is shown a length of insulating material **70** of the type that is commonly manufactured from fiberglass, rock wool, and similar insulating materials. The length of insulating material **70** takes the form of a batt which is typically dimensioned for installation between the studs or joists of a building. As is well known, the batt comprising the length of insulating material **70** may be encased in a plastic film wrap **72** formed from polyethylene, polypropylene, and/or similar plastic materials. The use of the wrap **72** is particularly advantageous in the case of fiberglass insulation in that it protects against painful skin irritations on the part of insulation installing personnel.

In accordance with the present invention, the plastic film wrap **72** surrounding the length of insulating material **70** is manufactured utilizing a blend of one or more plastic resins and one or more insect controlling chemical agents. The blended plastic resin/insect controlling chemical agent material is manufactured into plastic film utilizing conventional plastic film manufacturing techniques. When installed in a building, the plastic wrap **72** prevents insects from entering the building through the space between the structural members comprising the building and the insulating material installed therebetween.

Referring to FIG. **8**, there is shown a section of woven plastic fabric **80** constructed in accordance with the present invention. The woven plastic fabric **80** is preferably manufactured utilizing a blend of one or more plastic resins and one or more insect controlling chemical agents. The blended plastic resin/insect controlling chemical agent material is manufactured into woven plastic fabric utilizing conventional woven plastic fabric manufacturing techniques. For example, the fabric may be manufactured by first forming the blended plastic resin/insect controlling chemical agent material into a length of plastic film. Next, the plastic film is slit to provide a multiplicity of plastic filaments. The plastic filaments are thereafter woven to form the insect controlling woven plastic fabric of the present invention. Other well known techniques for manufacturing woven plastic fabrics may also be utilized in the practice of the invention, if desired.

Having reference to FIG. **9**, there is shown a woven plastic fabric **90** having a layer of insect controlling plastic material formed thereon. In accordance with the embodiment of FIG. **9**, the woven plastic fabric **90** may be conventional in nature, and may be manufactured using any of the various well known techniques for fabricating woven plastic fabrics. The layer **92** is preferably manufacturing utilizing a blend of one or more plastic resins and one or

more insect controlling chemical agents. The blended plastic resin/insect controlling chemical agent material is manufactured into insect controlling plastic coating material utilizing conventional plastic coating material manufacturing techniques. The insect controlling plastic coating material is then applied to the fabric **90** using conventional techniques.

For example, the layer **92** may be formed on the fabric **90** by means of extrusion, coating, spraying, etc. Alternatively, the layer **92** may be separately formed then secured on the fabric **90** utilizing conventional heat sealing or adhesive bonding techniques optionally, the layer **92** may be provided with apertures to permit the flow of water therethrough.

Referring again to FIG. **6**, a length of woven plastic fabric **100** incorporating the present invention may be deployed around the exterior of the building either during the construction of the building or as a part of maintenance procedures. The length of woven plastic fabric **100** is preferably manufactured either as illustrated in FIG. **8** or as illustrated in FIG. **9**. Regardless of the technique utilized in its manufacture, the length of woven plastic fabric **100** comprises an insect controlling layer which may be deployed on top of or somewhat under the surface of the soil surrounding a building. Preferably, the length of insect controlling woven plastic fabric **100** is deployed in accordance with well known techniques conventionally utilized in the control of termites and other insects.

Those skilled in the art will appreciate and understand the fact that the present invention comprises a variety of building materials each manufactured from a blended plastic resin/insect controlling chemical agent material which is transformed into a variety of building materials utilizing conventional manufacturing techniques. Each of the building materials manufactured in accordance with the invention contains one or more insect controlling chemical agents. Thus, when building materials manufactured in accordance with the present invention are utilized in the construction of a house or similar building, such materials deny access to the house or building by termites, carpenter ants, fleas, ticks, roaches, houseflies, and other undesirable insects.

Although preferred embodiments of the invention have been illustrated in the accompanying Drawings and described in the foregoing Detailed Description, it will be understood that the invention is not limited to the embodiments disclosed, but is capable of numerous rearrangements, modifications, and substitutions of parts and elements without departing from the spirit of the invention.

What is claimed is:

1. A method of controlling the entry of insects into buildings of the type comprising interconnected walls defining the interior of the building including the steps of:

- providing a thermoplastic resin selected from the group including polyethylene, polypropylene, polyurethane, and polystyrene;
- providing a quantity of fipronil;
- blending the selected thermoplastic resin with the fipronil to provide an insect controlling feedstock;
- extruding the insect controlling feedstock into an insect controlling film;
- slitting the film into strands;
- weaving the strands into an insect controlling fabric;
- wrapping the insect controlling fabric around the walls of the building thereby preventing insects from entering the building.