



US006340004B1

(12) **United States Patent**  
**Patton**

(10) **Patent No.:** **US 6,340,004 B1**  
(45) **Date of Patent:** **Jan. 22, 2002**

(54) **INTERNAL COMBUSTION ENGINE WITH REGENERATOR AND HOT AIR IGNITION**

FOREIGN PATENT DOCUMENTS

(76) Inventor: **Richard Patton**, 112 Planters Row, Starkville, MS (US) 39759

DE	40 24 558 A	2/1992
FR	2 291 351 A	6/1979
JP	56-27031	* 3/1981
WO	WO 99/30017	6/1999

(\* ) Notice: Subject to any disclaimer, the term of this patent is extended or adjusted under 35 U.S.C. 154(b) by 0 days.

\* cited by examiner

(21) Appl. No.: **09/651,482**

*Primary Examiner*—Noah P. Kamen

(22) Filed: **Aug. 30, 2000**

(74) *Attorney, Agent, or Firm*—Roberts Abokhair & Mardula, LLC

**Related U.S. Application Data**

(57) **ABSTRACT**

(60) Provisional application No. 60/151,994, filed on Aug. 31, 1999.

An internal combustion engine and method is disclosed wherein separate compression and power cylinders are used and a regenerator or pair of regenerators is mounted between them to provide heat for hot-air ignition. The single regenerator embodiment operates as a two-stroke cycle engine and the embodiment with an alternating pair of regenerators operates as a four-stroke cycle engine. Valving is provided for uniflow design and the system allows variable fuel ratios. The resulting engine achieves brake efficiency and thermal efficiency greater than 50%.

(51) **Int. Cl.**<sup>7</sup> ..... **F02B 47/00**; F01B 29/04

(52) **U.S. Cl.** ..... **123/25 C**; 123/70 R; 123/543; 123/559.1; 60/712

(58) **Field of Search** ..... 123/68, 70 R, 123/69, 72, 543, 556, 559.1, 25 C; 60/712

(56) **References Cited**

**U.S. PATENT DOCUMENTS**

4,157,080 A 6/1979 Hill ..... 125/53 B

**24 Claims, 11 Drawing Sheets**

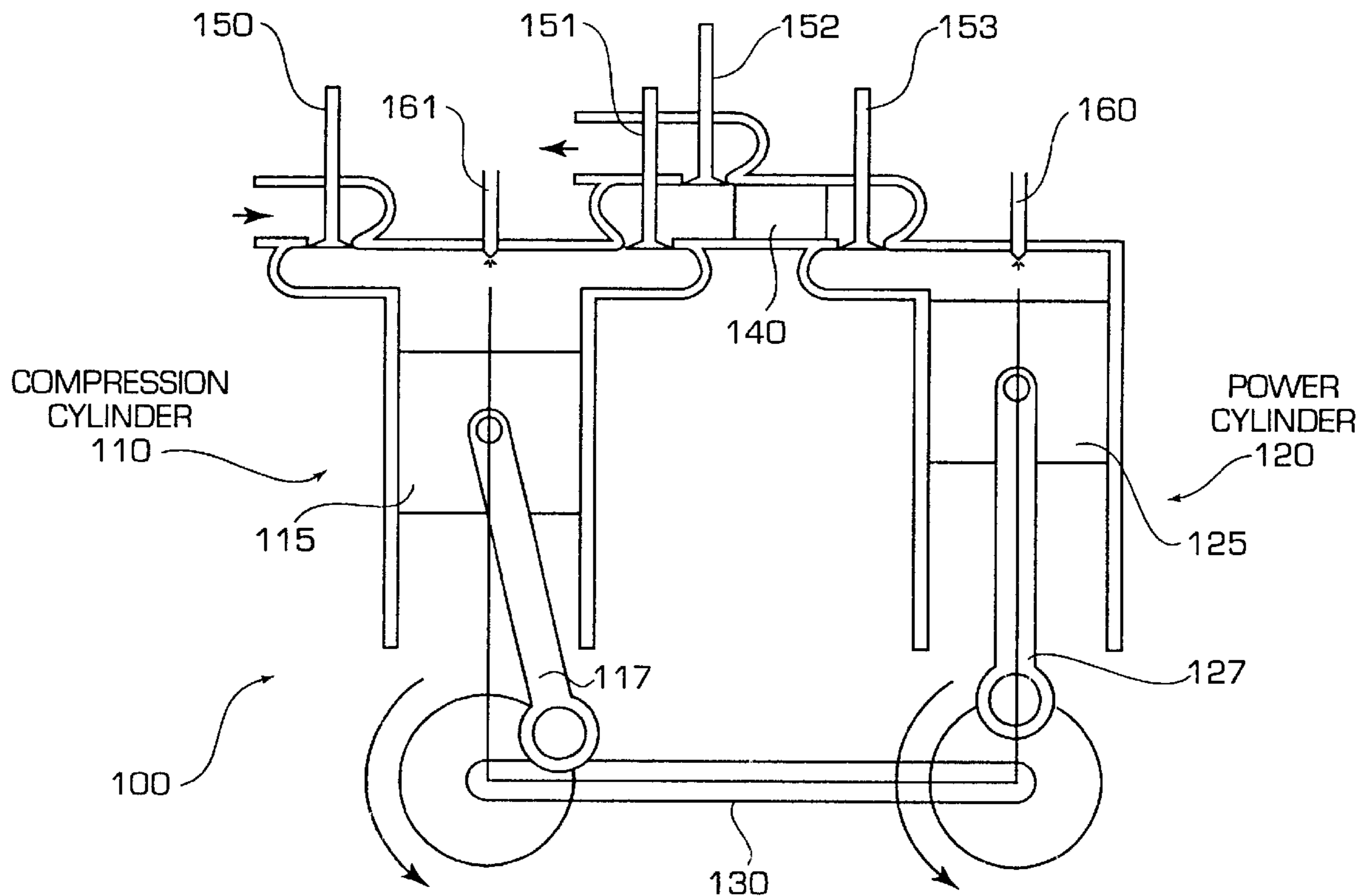

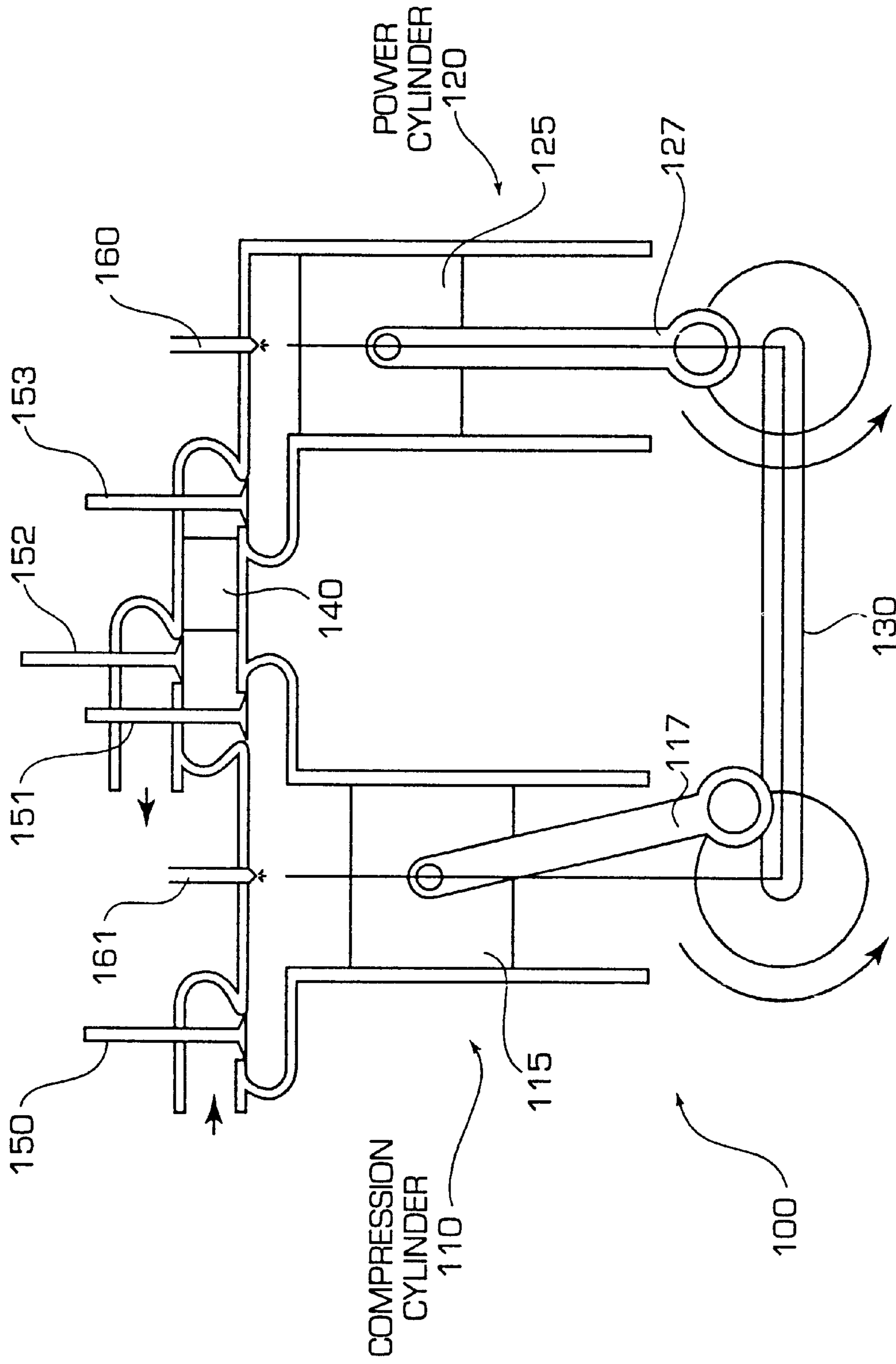

FIG. 1

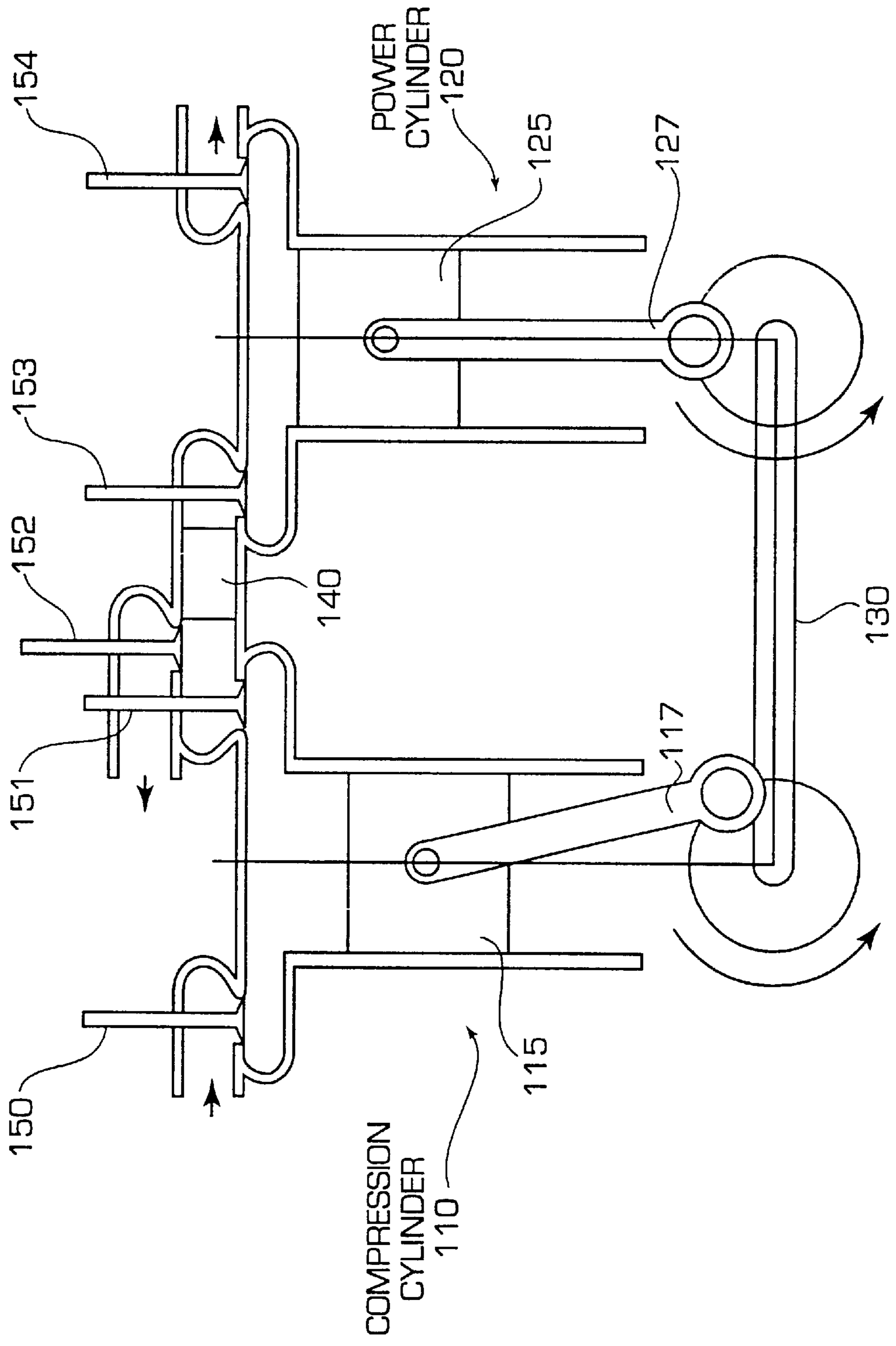
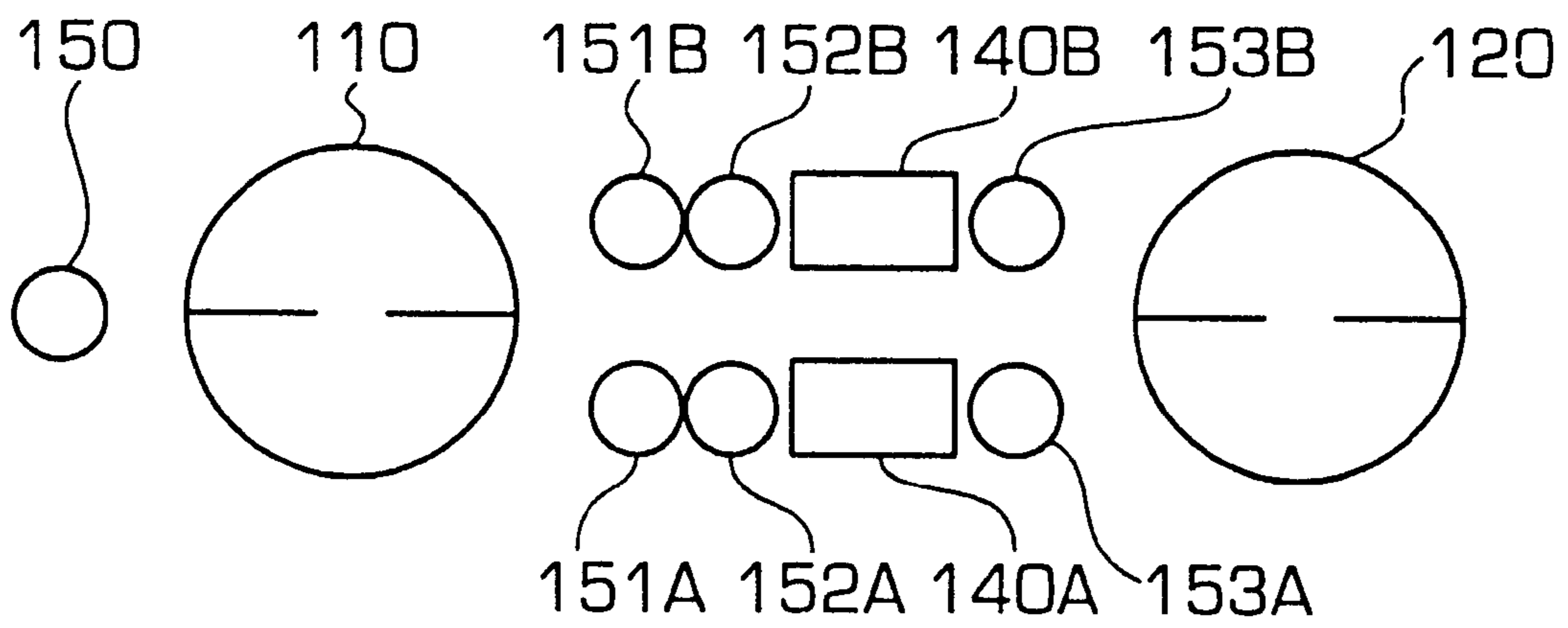

FIG. 2

FIG. 3A



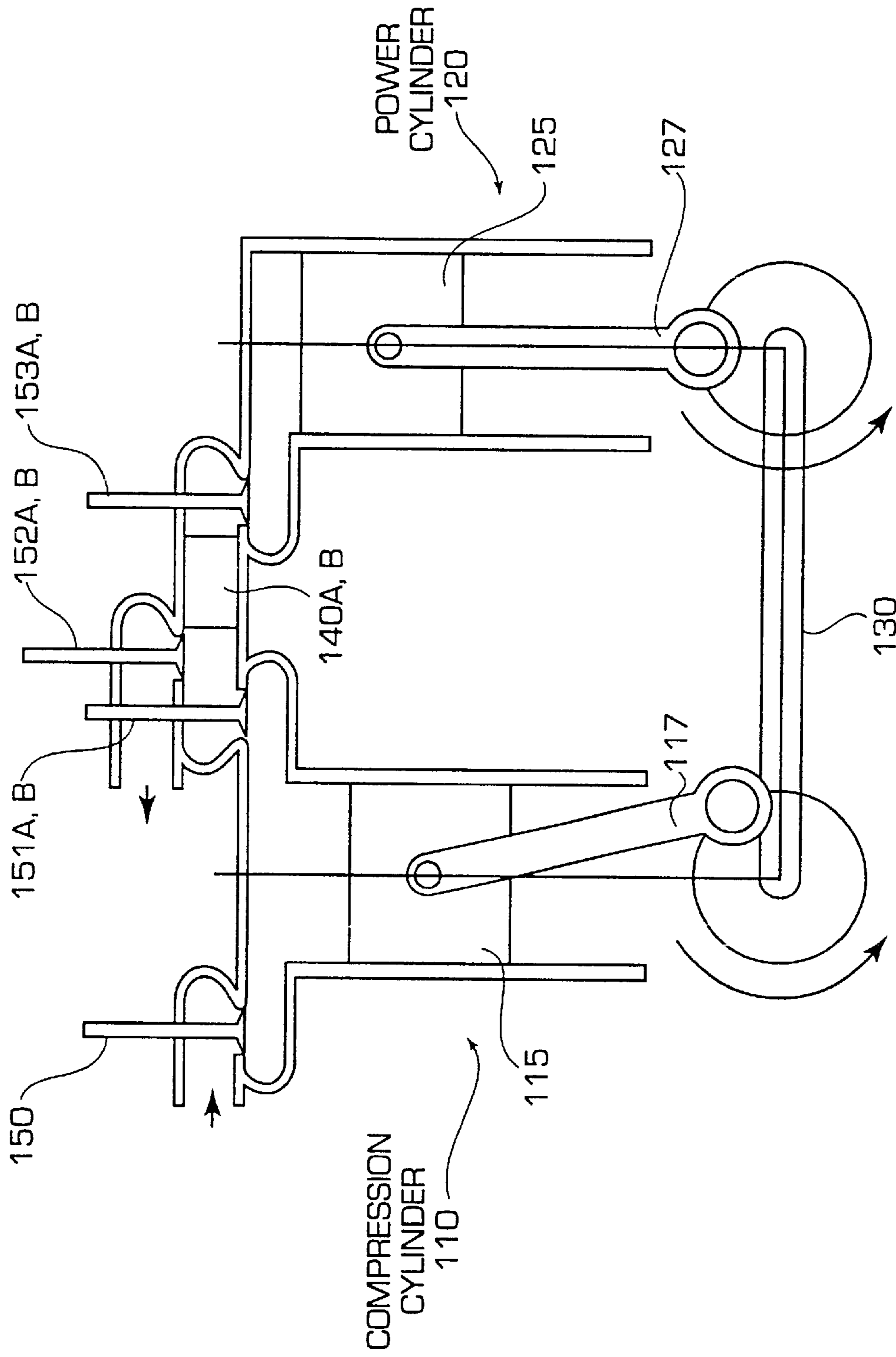

FIG. 3B

FIG. 4

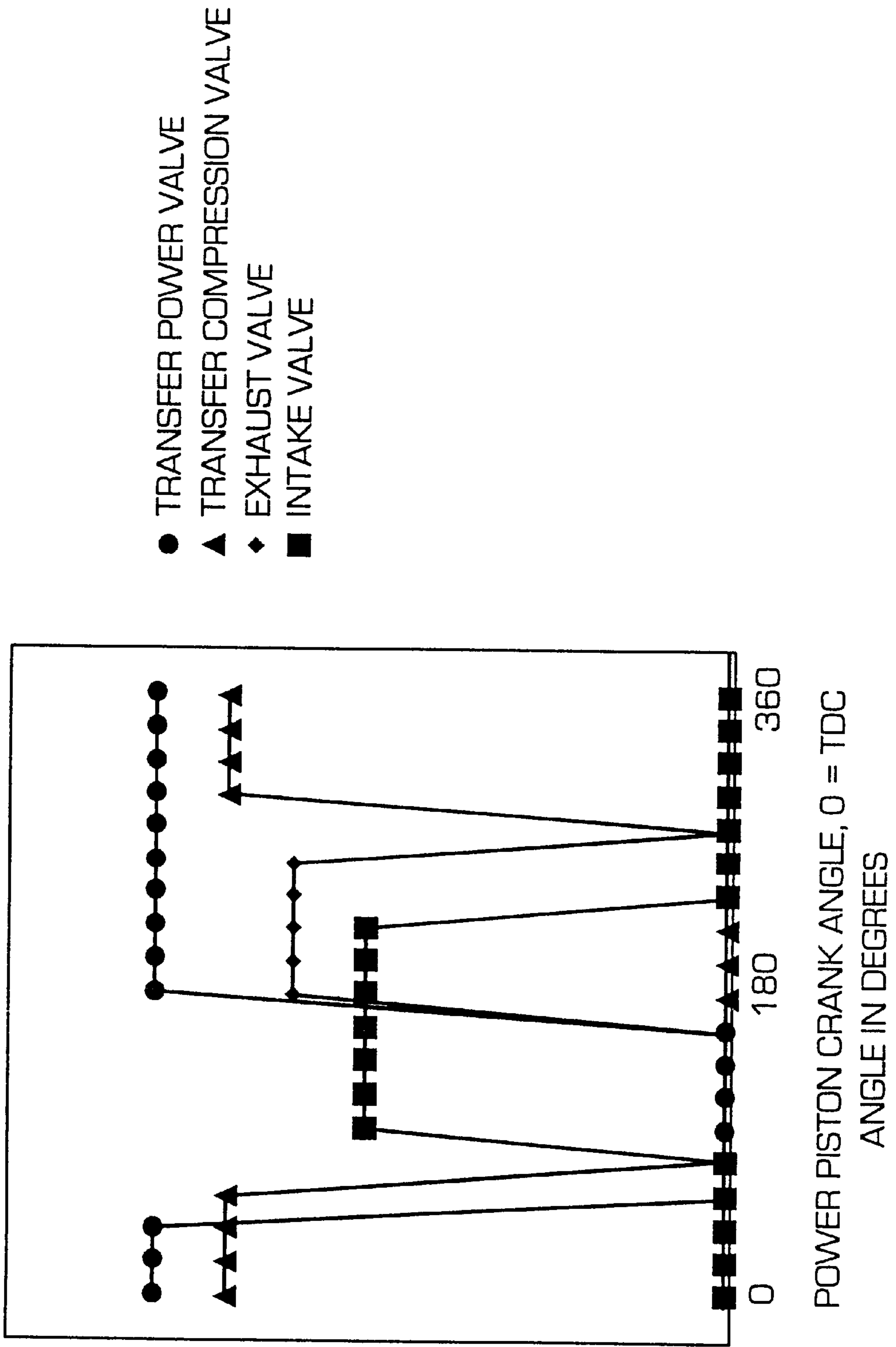

FIG. 5

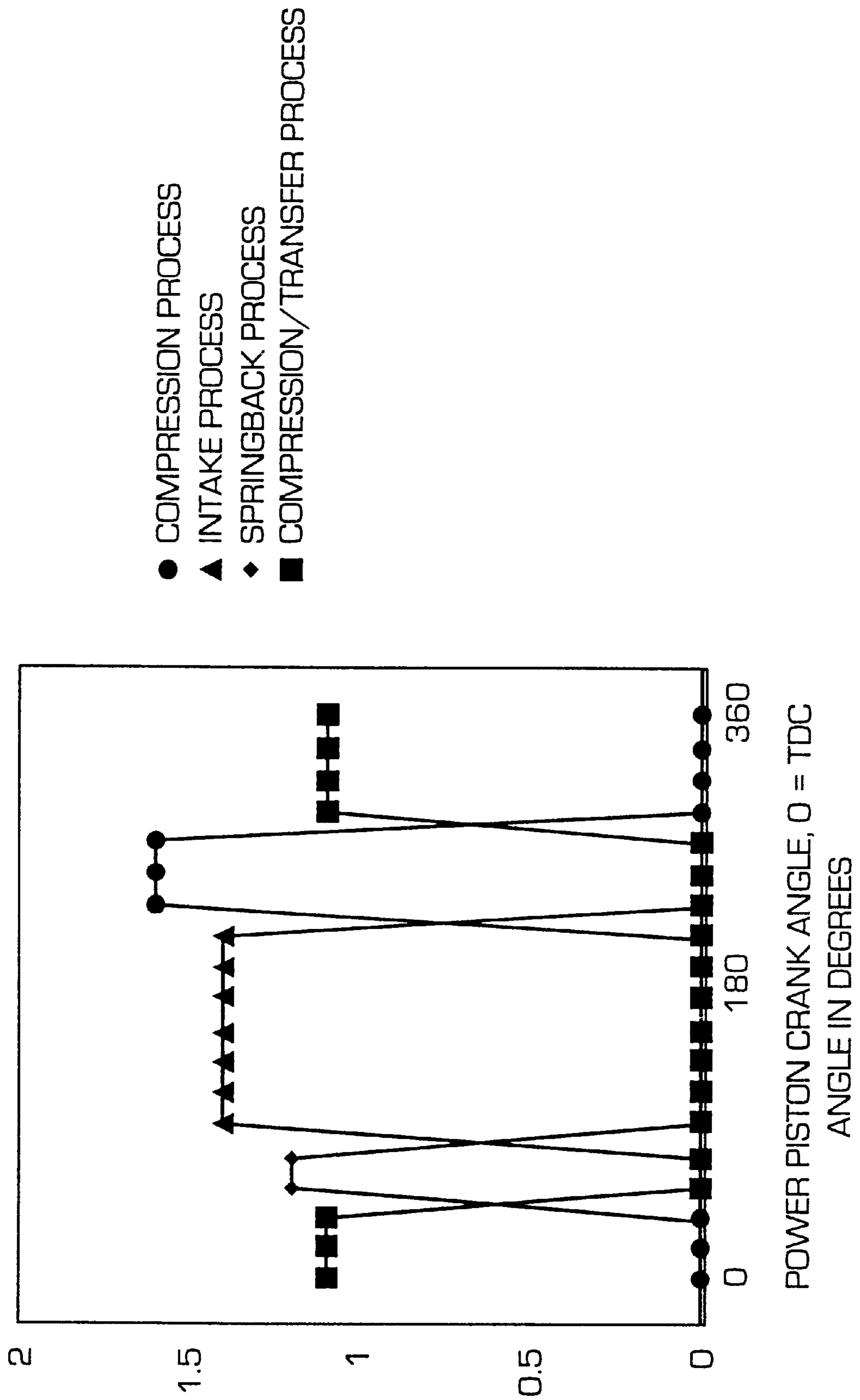
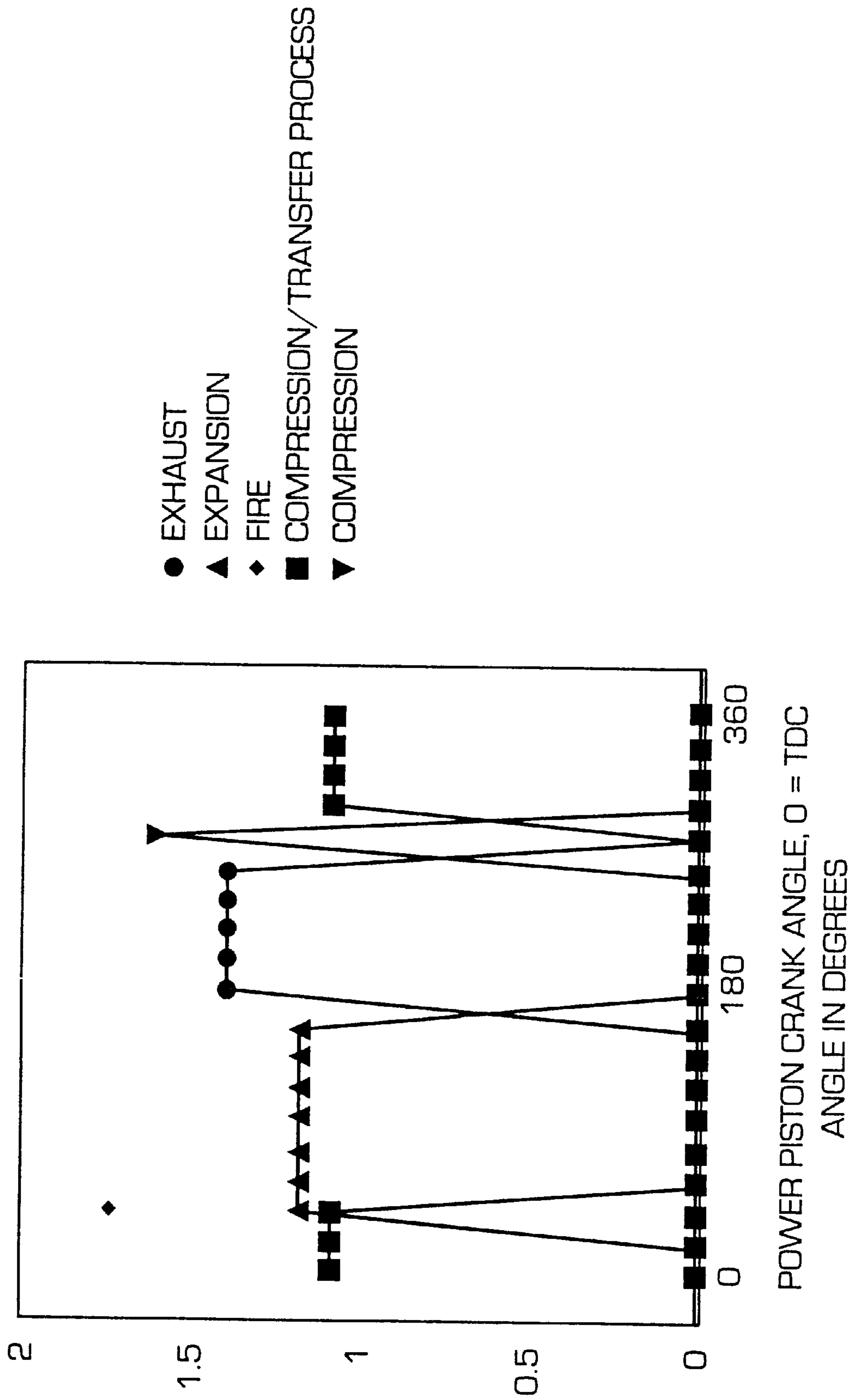



FIG. 6





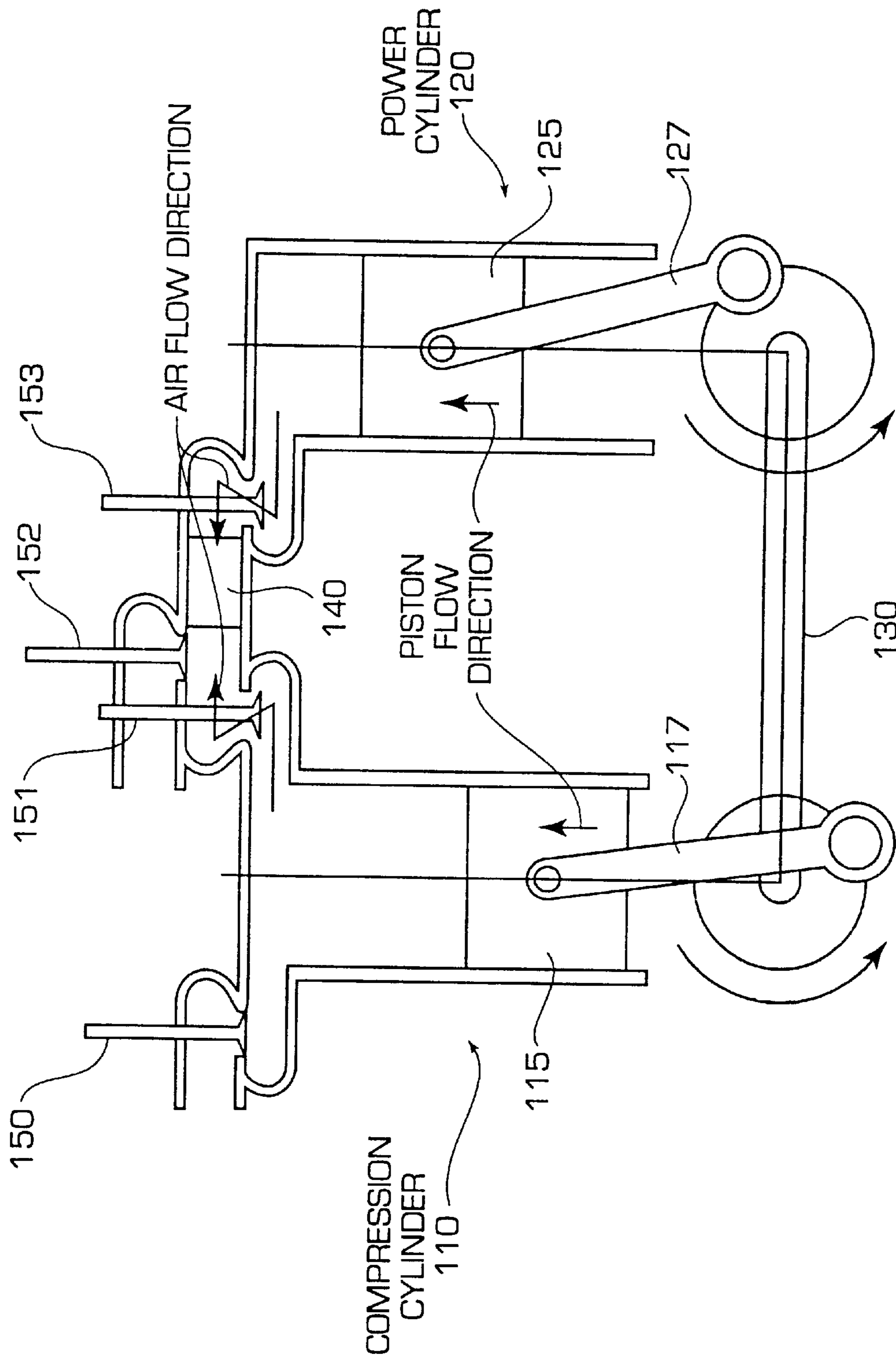

FIG. 7

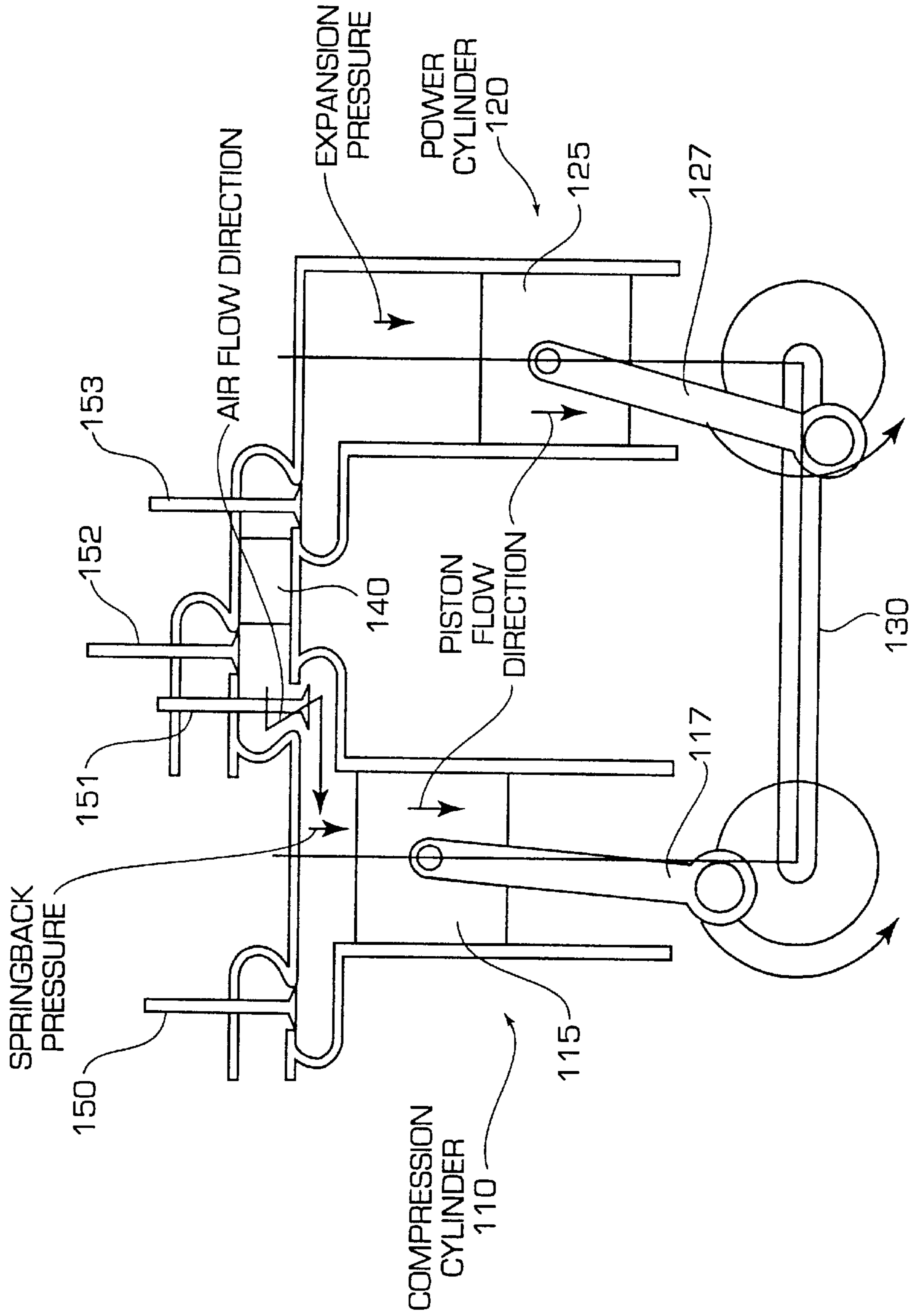

FIG. 8

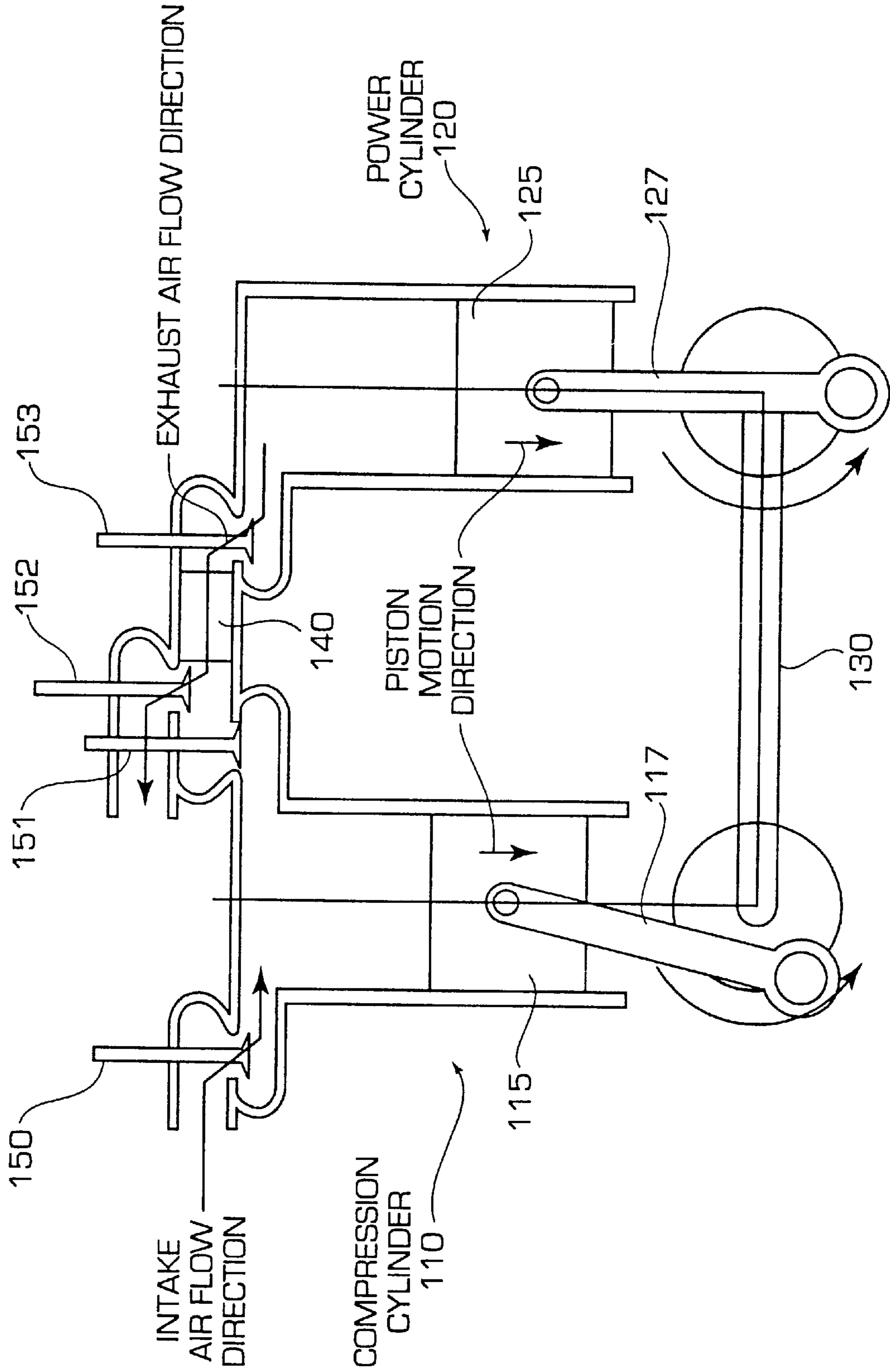

FIG. 9

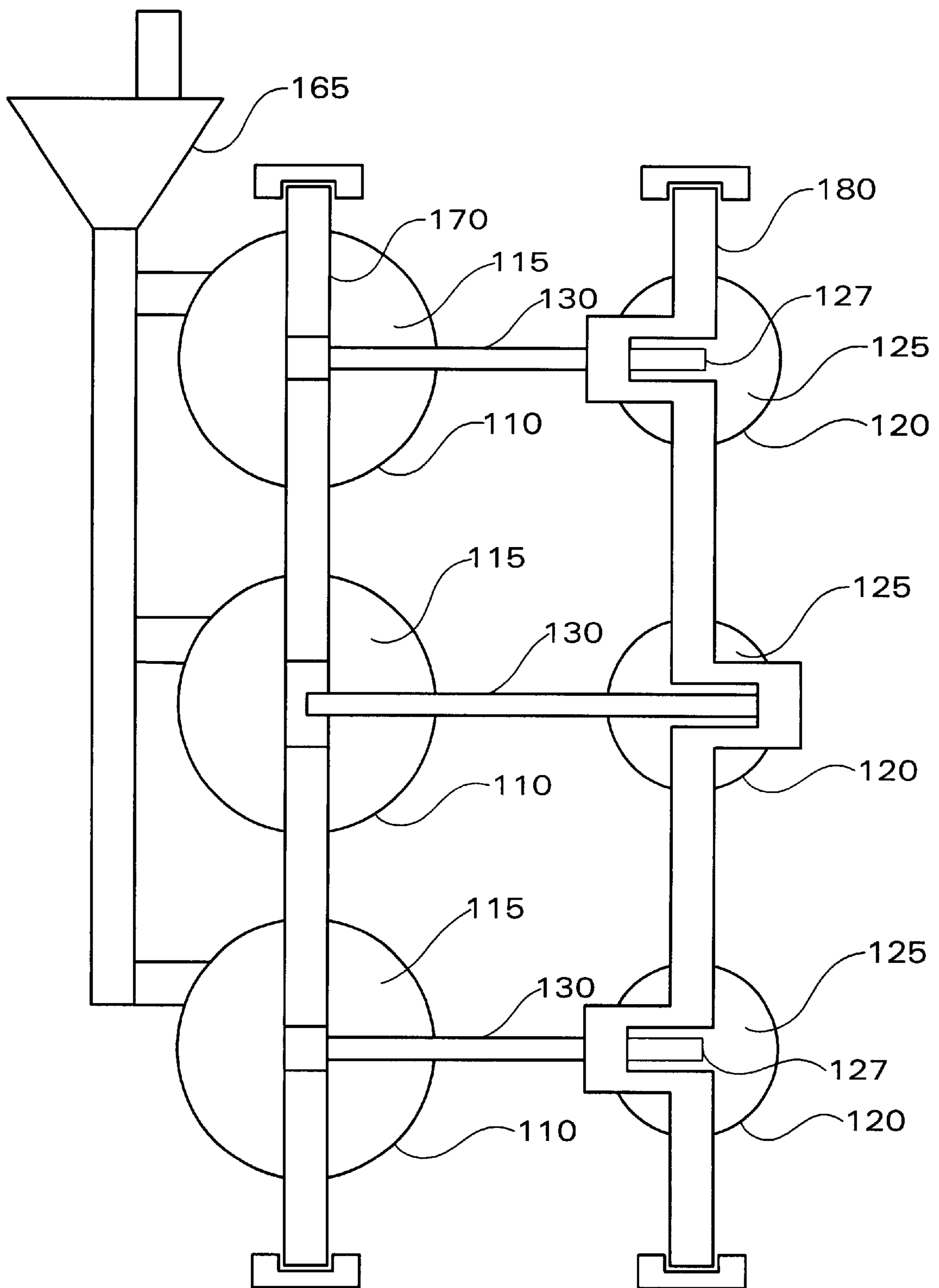

FIG. 10



## INTERNAL COMBUSTION ENGINE WITH REGENERATOR AND HOT AIR IGNITION

### RELATED APPLICATIONS

This application claims the benefit of Provisional Application No. 60/151,994, filed Aug. 31, 1999.

### FIELD OF THE INVENTION

This invention relates to the field of internal combustion engines, and in particular the improvement of their efficiency by using a regenerator. The engine of the present invention represents a combination of elements, which combined yield an engine with a brake efficiency of greater than 50%, which is competitive with fuel cells and other advanced movers.

### BACKGROUND OF THE INVENTION

The fuel economy of vehicles primarily depends on the efficiency of the mover that drives the vehicle. It is well recognized that the current generation of internal combustion (IC) engines lacks the efficiency needed to compete with fuel cells and other alternative vehicle movers. At least one study has recommended that auto manufacturers cease development of new IC engines, as they may be compared to steam engines—they are obsolete. The present invention is directed to an IC engine that is competitive with fuel cells in efficiency.

The following principles must be embodied in one engine in order for the engine to achieve maximum efficiency.

#### 1) Variable fuel ratio and flame temperature

For ideal Carnot cycle efficiency:

$$n=(T_h-T_l)/T_h$$

Where

$T_h$ =highest temperature

$T_l$ =lowest temperature (usually ambient temperature)

$n$ =thermal efficiency

shows that the higher the temperature,  $T_h$ , the higher the engine efficiency. This is not the case in real-world conditions. The basic cause of the breakdown in the Carnot cycle rule is due to the fact that the properties of air change as the temperature increases. In particular,  $C_v$ , the constant volume specific heat, and  $C_p$ , the constant pressure specific heat, increase as the temperature increases. The ratio  $k$ , on the other hand, decreases with increasing temperature. To heat 1 lb of air at constant volume by 100 degrees F. requires 20 BTU at 1000 degrees F., but 22.7 BTU at 3000 degrees F. The extra 2.7 BTU is essentially wasted. At the same time, each increment of  $T_h$  adds less and less to the overall efficiency. If  $T_l$  is 600 R, and  $T_h$  is 1800 R (1340 degrees F.),  $n=0.66666$ . At  $T_h=3600$  (3140 degrees F.),  $n=0.83333$ , and at  $T_h=5400$  R (4940 degrees F.),  $n=0.88888$ . In the first instance, going from 1800 R to 3600 R netted an increase in  $n$  of 0.16666, whereas going from 3600 R to 5400 R netted only an increase in  $n$  of 0.0555, or  $\frac{1}{3}$  of the first increase. At the same time, the specific heat of air is a monotonic function of temperature, so at some point the efficiency gains from higher temperatures are offset by losses due to higher specific heats. This point is reached at around 4000 R.

The most efficient diesels are large, low swirl DI (direct injection) turbocharged 2-strokes. These are low speed engines (<400 rpm) and typically have 100%–200% excess air.

The combustion temperature is proportional to the fuel ratio. A CI (compression ignition) engine will have a theo-

retical flame temperature of 3000–4000 R, as opposed to the SI (spark ignition) engine, which has a theoretical flame temperature of 5000 R. Note also that the reason the specific heat is increased is due to increased dissociation of the air molecules. This dissociation leads to increased exhaust pollution.

Ricardo increased the indicated efficiency of an SI engine by using hydrogen and reducing the fuel ratio to 0.5. The efficiency increased from 30% to 40%.

Hydrogen is the only fuel which can be used in this fashion. There are 2 basic types of ignition—spark and compression. This engine proposes to use hot air ignition (HAI), which allows variation in the fuel ratio similar to CI, but with the additional advantage that HAI does not require the engine do work to bring the air up to the temperature where it can be fired. All engines which claim to be efficient must use an ignition system which allows wide variations in the fuel ratio. An incidental advantage of this design is that because molecular dissociation is much less at lower temperatures, the resulting exhaust pollution (species such as nitrous oxide, ozone, etc) is also lessened.

#### 2) Uniflow Design

Uniflow design, although it is more critical to a Rankine cycle engine, such as the Stumpf Uniflow steam engine, is also of importance to an IC engine. Generally speaking, in a uniflow design, the motion of the working fluid into and out of the cylinder does not cause degradation of the cycle efficiency. The uniflow design minimizes unwanted heat transfer between engine surfaces and the working fluid. Only two-stroke cycle IC engines can claim some kind of uniflow design.

Consider the typical four-stroke cycle Diesel engine:

1) Intake—Air picks up heat from the intake valve and from the hot head, piston and cylinder. Generally speaking, the air heats up from 100–200 F.

2) Compression—The air continues picking up heat, in addition to the work done on it by the engine.

3) Power—Air is hot after firing, and begins to lose heat to the walls. Luminosity of the diesel combustion process accounts for much of the heat lost. The short cycle time of a high speed Diesel engine holds these heat losses by conduction to a minimum.

4) Exhaust—During the blowdown, heat is transferred to the exhaust valve, and hence to the cylinder head.

The engine of the present invention has separate cylinders for intake/compression and for power/exhaust. The intake/compression cylinder is cool, and in fact during the intake and compression process, efforts can be made to create a nearly isothermal compression process by adding water droplets to the intake air. Addition of water droplets is optional and is not essential to the design, which has had its efficiency calculations performed without taking water droplet addition into account.

Addition of water droplets, of course, is impossible with a Diesel engine. A variation on this is used in SI engines, where the heat of vaporization of the fuel keeps the temperature down during compression. This is one reason why methanol, which has a high heat of vaporization, is used in some high performance engines.

The power/exhaust cylinder is the 'hot' cylinder, with typical head and piston temperatures in the range of 1000–1100 F. This necessitates the use of 18/8 (SAE 300 series) stainless steels for the head and piston, and superalloys for the valves. Any other suitable high temperature material, such as ceramics, can also be used in the application. Combustion temperatures are in the neighborhood of 2000–3000 F. The high heat of the combustion chamber



prior to combustion reduces the heat transfer from the working fluid to the chamber during the power stroke. It also reduces the radiant heat transfer, however the larger reduction in radiant heat transfer comes from keeping the maximum temperature below 3000 F.

Thus, unwanted heat transfer is minimized in the engine of the present invention.

There are several dissociation reactions which become important absorbers of heat above 3000 F. The two most important are:



The production of CO, carbon monoxide, is particular undesirable, as it is a regulated pollutant. All of these reactions also reduce the engine efficiency.

### 3) Regenerator

In the use of a regenerator, the state of the art is not yet commercially feasible.

The principle of using a regenerator is not new. Siemens (1881) patented an engine design which was a forerunner of the engine of the present invention. It had a compressor, the air traveling from the compressor through the regenerator and into the combustion chamber. There are, however, some basic differences between the Siemens engine and the engine of the present invention:

1) Siemens proposed using the crankcase, rather than a separate cylinder, to compress the air. The engine appears to be a variation of Clerk's two-stroke cycle engine (1878). The engine features are:

- a) All of the compression occurs in the crankcase
- b) Max compression occurs at the wrong time on the stroke. It should occur at piston TDC, not BDC. This is remedied by use of a reservoir. This greatly increases the compression work.
- c) It is not clear that the Siemens engine can vary the fuel ratio. It is a spark ignition engine. Ignition is aided by adding oil to the regenerator as the fresh charge is passing through it.
- d) The Siemens engine had the regenerator as part of the top of the cylinder head. The regenerator is exposed to the hot flame, and some burning occurs in the regenerator.

In the engine of the present invention, the compressor takes in a charge of air, compresses it and then transfers the entire charge through the regenerator. The compressed charge includes the space taken up by the regenerator. At TDC of the power piston, (60 deg. bTDC of the compressor) the valve opens and the charge flows from the compressor to the power cylinder. Near TDC of the compressor, fuel is sprayed into the power cylinder. Dead air is minimized throughout the system in order to realize the benefits of the regenerator and minimize compressor work. During combustion, the regenerator is separated from the burning gases by a valve.

Hirsch (155,087?) has two cylinders, passages between them, and a regenerator. Air from explosion in the hot cylinder is forced from the hot cylinder to the cold cylinder, where jets of water are used to cool the air and form a vacuum. It appears to be a hot air engine, does not specify an ignition system, and contains a pressure reservoir.

Koenig (U.S. Pat. No. 1,111,841) is similar in design to the engine of the present invention. It has a power cylinder and a compression cylinder and a regenerator in between. It does not specify the method of firing the power piston, and

the valving is somewhat different. In particular, the inventor failed to specify a valve between the power piston and the regenerator. This results in the air charge being transferred from the compression cylinder into a regenerator at atmospheric pressure. As the compression cylinder is smaller than the engine cylinder, this will cause a loss of pressure during the transfer process.

Ferrera (U.S. Pat. No. 1,523,341) discloses an engine with 2 cylinders and a common combustion chamber. It differs substantially from engine of the present invention.

Metten (U.S. Pat. No. 1,579,332) discloses an engine with 2 cylinders and a combustion chamber between them.

Ferrenberg (see U.S. Pat. Nos. 5,632,255, 5,465,702, 4,928,658, and 4,790,284) has developed several patents drawn to a movable thermal regenerator. The engine of the present invention has a fixed regenerator.

Clarke (U.S. Pat. No. 5,540,191) proposed using cooling water in the compression stroke of an engine with a regenerator.

Thring (U.S. Pat. No. 5,499,605) proposed using a regenerator in a gasoline engine. That invention differs greatly from present hot-air ignition system.

Paul (U.S. Pat. Nos. 4,936,262 and 4,791,787) proposed to have a regenerator as a liner inside the cylinder.

Bruckner (U.S. Pat. No. 4,781,155) has some similarities to the engine of the present invention. In this patent, fresh air is admitted to both the power cylinder and the compression (supercharger) cylinder. This differs from the engine of the present invention, as fresh air is only admitted to the compression cylinder. In addition, there is no valving controlling the flow of air through the regenerator. The cylinders are out of phase, but the phasing varies.

Webber (U.S. Pat. No. 4,630,447) has a spark-ignition engine in which there are two cylinders out of phase with each other, with a regenerator in between. However, there is no valving controlling the movement of air in the regenerator as with the present invention.

Millman (U.S. Pat. No. 4,280,468) has a single cylinder engine in which a regenerator is placed between the intake and exhaust valves on the cylinder head. Very different from the engine of the present invention.

Stockton (U.S. Pat. No. 4,074,533) has a modified Sterling/Ericsson engine with intermittent internal combustion and a regenerator.

Cowans (U.S. Pat. No. 4,004,421) has a semi-closed loop external combustion engine.

Several U.S. patents were mentioned in the above patents. The most common for the closely allied patents were: U.S. Pat. Nos. 1,682,111, 1,751,385, 1,773,995, 1,904,816, 2,048,051, 2,058,705, 2,516,708, 2,897,801, 2,928,506, 3,842,808, 3,872,839, 4,026,114, 4,364,233, 5,050,570, 5,072,589, 5,085,179, 5,228,415

### 4) Low Friction & Compression Ratio

In a regenerative engine scheme, the compression ratio needs to be low. It turns out that having a low compression (and expansion) ratio has the following advantages:

1) low friction mean effective pressure (fmep). fmep consists of rubbing and accessory mep (ramep) and pumping mep (pmep). Because the engine of the present invention is not throttled, there is very little pmep. The pmep in the engine of the present invention will primarily come from transfer of the air from the compression to the power cylinder and is generally no more than 1-2 psi at 1800 rpm.

Ramep should be very low, as peak pressures are low and compression ratios are low.

2) Efficiency is high. This is due to the fact that the waste heat is recovered from the exhaust. It is more efficient



to have a low compression ratio and recover much waste heat than it is to have a high compression ratio and recover a small amount of waste heat. The low compression ratio engine acts much more like a Sterling engine and hence its maximum possible efficiency is greater.

Almost by definition, a high friction engine cannot be efficient. None of the engines with regenerators in the patents mentioned having a low compression ratio, except Webber (U.S. Pat. No. 4,630,447), which has a 4:1 compression ratio. Webber also calls his engine an "open cycle Sterling engine."

The current state of the art as commercially practiced does not produce engines that have adequate fuel economy. The state of the art as practiced in the patent literature does not adequately regulate the air flow through the regenerator. For example, in Webber's patent, hot gases can transfer unimpeded from the hot side to the cool side after firing. As these hot gases are expanding, the reduction in volume in this movement causes loss of power and efficiency. The regenerator picks up combustion heat, not exhaust heat.

#### BRIEF SUMMARY OF THE INVENTION

The internal combustion engine of the present invention combines the fuel-saving features of a variable fuel ratio, low flame temperature, low heat losses, and high volumetric efficiency by using separate compression and power cylinders connected by a regenerator with a uniflow design so as to enable hot air ignition.

It is therefore an object of the invention to provide an internal combustion engine having extremely high efficiency.

It is a further object of the invention to provide an internal combustion engine that produces very little pollution.

#### BRIEF DESCRIPTION OF THE DRAWINGS

FIG. 1 illustrates a four-valve engine of the present invention.

FIG. 2 illustrates a five-valve engine of the present invention.

FIGS. 3a–b illustrate a seven-valve engine of the present invention.

FIG. 4 illustrates a typical valve opening diagram of a four-valve engine of the present invention.

FIG. 5 illustrates a typical compression cylinder processes and valve opening diagram of a four-valve engine of the present invention.

FIG. 6 illustrates a typical power cylinder process and valve opening diagram of a four-valve engine of the present invention.

FIG. 7 illustrates a four-valve engine compression/transfer process of the present invention.

FIG. 8 illustrates a four-valve engine expansion and springback process of the present invention.

FIG. 9 illustrates a four-valve engine intake and exhaust process of the present invention.

FIG. 10 illustrates another embodiment of the present invention.

#### DETAILED DESCRIPTION OF THE INVENTION

The engine of the present invention has separate cylinders for intake/compression (compression) and for power/exhaust (power). The compression cylinder is cool, and in

fact during the intake and compression process, efforts can be made to create a nearly isothermal compression process by optionally adding water droplets to the intake air.

The power cylinder is the 'hot' cylinder, with typical head and piston temperatures in the range of 1000–1100 F. This necessitates the use of 18/8 (SAE 300 series) stainless steels for the head and piston, and superalloys for the valves. Combustion temperatures are in the neighborhood of 2000–3000 F. The high heat of the combustion chamber prior to combustion reduces the heat transfer from the working fluid to the chamber during the power stroke. It also reduces the radiant heat transfer, however the larger reduction in radiant heat transfer comes from keeping the maximum temperature below 3000 F.

The compression and power cylinders are connected by a regenerator and the compression and power pistons are driven 30–90 degrees out of phase. The valve arrangement of the compression cylinder, regenerator and power cylinder, consisting of between four and seven valves, operates to provide a uniflow design.

In operation, the compressor takes in a charge of air, compresses it and then transfers the entire charge through the regenerator. The compressed charge includes the space taken up by the regenerator. At TDC of the power piston, (60 deg. bTDC of the compressor) the valve opens and the charge flows from the compressor to the power cylinder. Near TDC of the compressor, fuel is sprayed into the power cylinder. Dead air is minimized throughout the system in order to realize the benefits of the regenerator and minimize compressor work. During combustion, the regenerator is separated from the burning gases by a valve.

During the power stroke, the regenerator connection needs to be cut. If it isn't, the regenerator will perform unwanted transfers of gases from one side to the other. To avoid power-robbing pressure mismatches, the regenerator connection should only be altered when one or the other of the pistons is at TDC (top dead center), and it should only be opened when it is desired to transfer cool side gases to the hot side.

During the compression stroke, it is possible to open both sides of the regenerator connection. This should be done only after exhaust blowdown is completed, and when the pressures in both cylinders are relatively low.

After the compression stroke, the regenerator connection is cut between the power cylinder and the regenerator. The firing of the air takes place nearly simultaneously; the pressure rise due to the combustion helps to close the valve.

After firing, there is compressed air in the regenerator and in the passages leading between the cylinders. This compressed air is re-admitted to the compression cylinder, where it does useful work on the downstroke. This feature tends to make the engine more buildable, as the need for very small passages is reduced. The size of the regenerator and the passages has a much smaller effect on engine efficiency with this feature. This will be referred to as the "springback process," because the compressed air springs back into the compression cylinder.

As illustrated in FIGS. 1–2, the internal combustion engine 100 has a (cold) compression cylinder 110, and a (hot) power cylinder 120. Both cylinders have pistons 115 and 125 connected by connecting rods 117 and 127 to a common crankshaft 130, with the power piston 125 leading the compression piston 115 by 30–90 degrees (60 degrees shown). The cylinders 110, 120 are connected by either one or two separate regenerators 140. When the engine 100 is constructed with only one regenerator, there are two vari-



ants: a four valve configuration, as shown in FIG. 1 and a five valve configuration, as shown in FIG. 2. In the five valve configuration, the power cylinder 120 is equipped with an additional exhaust valve 154, and not all of the hot working fluid passes through the regenerator 140 on its way to the exhaust. In the four valve configuration, all of the hot working fluid passes through the regenerator 140, but some of it is pushed back into the compression cylinder 110. The fuel is fired in the power cylinder 120. The valving 150–153/154 is so arranged that the compression piston 115 compresses gas in both the cylinder 110 and in the regenerator 140, and the power piston 125 is pushed by gases in the power cylinder 120. Compressed air begins passing through the regenerator 140 to the power cylinder 120 when the power piston 125 is at TDC. At the end of the fluid transfer (near compression cylinder TDC) the valve 153 between the power cylinder 120 and the regenerator 140 is closed and the fuel is fired in the power cylinder 120. In the meantime, compressed air from the regenerator 140 and the passage(s) between the cylinders is allowed to flow back into the compression cylinder 110, where it does useful work on the downstroke. The intake valve 150 opening is delayed until after this takes place.

At this point, the intake valve 150 is opened and the valve 151 between the regenerator 140 and the compression cylinder 110 is closed. At BDC (or shortly thereafter) of the compression piston 115, the intake valve 150 is closed. At or near BDC of the power piston 125, the exhaust valve 153 is opened on the regenerator 140, the connection valve 153 is opened between the regenerator 140 and the power cylinder 120, and the hot fluid passes through the regenerator 140 and exhausts. Engine 100 will be fired by fuel injection into the power cylinder 120 near the end of fluid transfer. Heat from the regenerator 140 will be sufficient to ignite the fuel. The exhaust valve 152 on the regenerator 140 is closed sometime after the blowdown.

There are two variants of the single regenerator design, as discussed above.

#### Four Valve

In the four valve design of FIG. 1, the valve 151 between the compression cylinder 110 and the regenerator 140 is opened, and the hot gases in the power cylinder 120 are pushed into the compression cylinder 110. This does not have a large effect on the efficiency, although it does tend to degrade it slightly.

The engine cycle can be broken down into a series of processes:

#### Power cylinder:

- Compression/transfer
- Ignition
- Expansion
- Exhaust
- Compression

#### Compression cylinder:

- Compression/transfer
- Springback
- Intake
- Compression

During the compression/transfer process of both cylinders, the intake and exhaust valves 150 and 152 are closed, but the transfer valves 151 and 153 between the cylinders are open, allowing gases to flow freely through the regenerator 140 from one cylinder to the other. Because the power cylinder 120 leads the compression cylinder 110, when the compression piston 115 approaches top dead center (TDC), the power piston 125 is on its downstroke, the gases are compressed and most of the gases are in the power cylinder 120.

During the ignition/expansion in the power cylinder 120 and springback in the compression cylinder 110, fuel is sprayed into the power cylinder 120. After an ignition delay, the mixture fires. The sharp pressure rise forces the transfer valve between the power cylinder 120 and the regenerator (which was almost closed anyway) closed, and the hot gases expand in the power cylinder 120, doing work. In the meantime, the transfer valve between the compression cylinder 110 and the regenerator has remained open, and the compressed gases in the regenerator and passages “spring-back” into the compression cylinder 110 and begin doing work on the compression piston.

During springback, the pressure in the compression cylinder 110 falls. As it nears atmospheric pressure, most of the work from the compressed gases in the regenerator and passages has been captured. At this time, the intake valve opens and the transfer valve between the compression cylinder 110 and the regenerator closes. The compression cylinder 110 begins the intake of fresh air for the next cycle.

About 20 degrees before bottom dead center (BDC) in the power cylinder 120, the exhaust valve is opened and the transfer valve between the power cylinder 120 and the regenerator is opened. The two valves do not need to open simultaneously. However the exhaust valve will usually open prior to the transfer valve. Gases begin exhausting out of the power cylinder 120, through the regenerator and into the atmosphere. The regenerator gains much of the heat of the exhaust, capturing it for the next cycle. The exhaust process goes through a violent blowdown, after which time the hot gases in the power cylinder 120 are at nearly atmospheric pressure. The exhaust process is normally begun before BDC so that the on the upstroke the hot gases are at near atmospheric pressure and so do not do much negative work. The exhaust process ends when the exhaust valve closes.

After the intake in the compression cylinder 110 ends (after BDC), the intake valve is closed and the gases in the compression cylinder 110 begin to be compressed. Similarly, after the exhaust process is completed, the exhaust valve is closed, also after BDC, the hot gases in the power cylinder 120 begin to be compressed. The transfer valve between the power cylinder 120 and the regenerator remains open. The timing of the compression is such that both cylinders have approximately equal pressures. The transfer valve from the compression cylinder 110 to the regenerator is opened, and the compression/transfer process is begun. Gas can again flow freely from one cylinder to the other. Because the pressures in both cylinders are nearly equal, very little work is lost by opening the compression transfer valve.

#### Five Valve

In this design, the transfer/compression process is altered.

A major objection to the four valve is the re-compression of hot exhaust gases, which robs the engine of work. A complete separation of the exhaust and compression processes is achieved in the 5-valve engine. During the exhaust cycle, the valve between the power cylinder 120 and the regenerator is closed, and the rest of the exhaust process takes place through the 5th valve, which is a 2nd exhaust valve on the power cylinder 120.

There is no compression process in the power cylinder 120. After the exhaust valve and valve between the regenerator and the power cylinder 120 are closed, the valve between the regenerator and the compression cylinder 110 is opened. Compression proceeds in the compression cylinder 110 until the power cylinder 120 piston reaches TDC, at which point the transfer valve between the power cylinder 120 and the regenerator is opened, the 2nd exhaust valve is



closed, and compressed air flows into the power cylinder **120**. Thus, in this design, the exhaust, compression and transfer processes are distinct.

The design has two major disadvantages. One disadvantage is that the hot gases from the 2nd exhaust valve bypass the regenerator, causing heat losses. The 2nd disadvantage is that the valving is significantly more complex. In particular, the valve from the regenerator to the power cylinder **120** is only open a short period of time, which makes designing the camshaft for this design much more difficult, as the cam accelerations are much higher.

Seven valve

Alternatively, the cylinders are connected by two separate regenerators, which operate out of phase from each other. Each regenerator has 3 valves: a valve leading from the regenerator to the power cylinder **120**, a valve leading from the regenerator to the compression cylinder **110**, and a cold side valve connecting the regenerator to the exhaust. The compression cylinder **110** also has an intake valve. To avoid valve overlap, fluid is transferred on alternate revolutions through different regenerators. While this is a significantly more complex valving system, it has the advantage that all of the hot exhaust passes through a regenerator. If the regenerators double as catalytic converters, this scheme will be much more favorable for pollution control, as all of the exhaust gas can be treated in the regenerators.

On the downside, the complex valving system tends to be very difficult to design. In particular, the camshaft design is very difficult; the valves do not stay open long enough to permit efficient cam design.

This problem is not shared by the four valve design, which is a true two-stroke cycle design. In this design, the valves stay open long enough to permit good cam design, and all of the exhaust flows through the regenerator, which can double as a catalytic converter. Thus the four valve design is a simpler, more buildable design, and although it compromises efficiency somewhat, it retains most of the features for a very efficient engine. Thus the four valve system is the preferred embodiment.

From a technical standpoint, the engine is a two-stroke engine, in which there is an outside compressor. Because the engine is integral with the compressor, which supplies compressed air to the cylinder, the engine can be considered to be a four-stroke engine in which the intake and compression strokes occur in the compression cylinder **110**, and the power and exhaust strokes occur in power cylinder **120**.

FIG. 4 shows the valving for the four valve, one regenerator engine. The valve timing is typical of these engines. The four valves are:

1. Intake valve—valve **150** from the intake manifold to the compression cylinder **110**
2. Transfer compression valve—valve **151** from the compression cylinder **110** to the regenerator **140**
3. Exhaust valve—valve **152** from the passage between the compression cylinder **110** and the regenerator **140** to the exhaust manifold.
4. Transfer power valve—valve **153** from the power cylinder **120** to the regenerator **140**.

FIG. 5 shows the compression cylinder **110** processes, and FIG. 6 shows the power cylinder **120** processes. The valves are closed when the valving diagram shows the valve at zero, and open when the valve is at a positive number. Similarly, the processes in FIGS. 5–6 are proceeding when the process is at a positive number. For clarity, valve

openings and processes are shown at different levels. The x-axis is meant to show the progression of the cycle, rather than exact opening and closing (or start and end) times.

At the start of the cycle (power piston TDC) the power piston **125** has reached the top of its stroke and is starting to descend. The compression piston **115** lags the power piston **125**, and so it is still on its upstroke. Both the transfer compression valve **151** and the transfer power valve **153** are open, so gases can flow freely from one cylinder to the other. Because the compression piston **115** is on its upstroke and the power piston **125** is on its downstroke, air is transferred from the compression cylinder **110**, is heated passing through the regenerator **140**, and goes into the power cylinder **120**. All other valves are closed. This is the transfer portion of the compression/transfer portion of the cycle.

FIG. 7 shows the four valve engine during this process. This is the transfer portion of the compression/transfer portion of the cycle. The transfer power valve **153** closes, and the engine fires. Fuel has been injected into the power cylinder **120** prior to this time, and after an ignition delay it burns very rapidly. The fuel injection at **160** is timed so this rapid burn occurs at the correct time (fire point) in the cycle. The power cylinder **120** begins its expansion process, and the compression cylinder **110** begins its springback process. The transfer power valve **153**, the intake valve **150** and the exhaust valve **152** are closed, and only the transfer compression valve **151** is open. FIG. 8 shows the four valve engine during this process.

The springback process ends, and so the transfer compression valve **151** closes while the intake valve **150** opens. This begins the intake process in the compression cylinder **110**. At a somewhat later time, the exhaust valve **152** opens, and simultaneously or slightly after that time, the transfer power valve **153** opens. This begins the exhaust process in the power cylinder **120**. FIG. 9 shows the four valve engine when both of these processes are underway.

The intake valve **150** closes, and this begins the compression process in the compression cylinder **110**. At a different time, usually later, the exhaust valve **152** closes. This begins the compression process in the power cylinder **120**. The two compression processes are different processes.

Finally, the transfer compression valve **151** opens. This begins the compression portion of the compression/transfer process, which completes the cycle.

Table 1 shows the valving for the one-regenerator engine variant having five valves, as shown in FIG. 2—an intake valve **150** and a transfer compression valve **151** (leading to the regenerator **140**) on the compression cylinder **110** head, an exhaust valve **152** on compression side of the regenerator **140**, a transfer power valve **153** (leading to the regenerator **140**) and an exhaust valve **154** on the power cylinder **120** head. The exhaust valve **154** leads to a 2nd exhaust manifold. The valving in 30° increments is as follows:

1. Start: air is beginning to be transferred from the compression cylinder **110** to the power cylinder **120**. As it is transferred, it passes through the regenerator **140**, which heats it up. To facilitate transfer, the compression piston **115** lags the power piston **125**. During transfer, the transfer compression valve **151** is open, the transfer power valve **153** open, and the other three valves are closed.
2. (30°) Transfer continues.
3. (60°) Transfer ends. The amount of crank angle for the transfer is equal to the lag of the compression piston



## 11

**115** to the power piston **125**. In this example, the lag was exactly  $60^\circ$ , but the exact amount of the lag can vary. This phase lag has an important effect, since it determines the compression ratio of the engine. At the end of transfer, the transfer compression valve **151** 5 remains open, starting the springback process, and the transfer power valve **153** closes. This shuts off flow from the regenerator **140** to the power cylinder **120**.

4. Combustion now takes place. Fuel is sprayed into the power cylinder **120**, which fires. The air has picked up enough heat from the regenerator to ignite the fuel ( $>900^\circ$  F.). In actual operation, the fuel would be sprayed slightly before this time, to allow time for the fuel to ignite. 10
5. ( $90^\circ$ ) The power cylinder **120** is on its expansion (power) process. The transfer compression valve **151** closes, and the intake valve **150** opens. The compression cylinder **110** begins its intake process. Water or vaporizable fuel can be added during the intake stroke via **161** to assist in providing the nearly isothermal compression later in the cycle. 15
6. ( $120^\circ$ ) Continuation of the expansion and intake processes. 20

## 12

12. ( $300^\circ$ ) Blowdown through the regenerator **140** ends. The exhaust valve **152** closes, the transfer power valve **153** closes and the exhaust valve **154** opens. This routes the exhaust to the second exhaust manifold. Whatever heat is left in the power cylinder gases is lost. {Note: Calculations have shown that over 80% of the heat goes through the regenerator, but 100% of the exhaust passes through a regenerator in the seven valve two-regenerator engine and in the four valve engine. If the regenerator contains a catalytic converter and particulate filter, having only a portion of the exhaust may have a negative effect on emissions.} The transfer compression valve **151** on the compression cylinder **110** is opened, so that the gases in both the compression cylinder **110** and in the regenerator **140** and its passages will be compressed for the next cycle.
13. ( $330^\circ$ ) Compression and exhaust processes continue.
14. ( $360^\circ$ ) Power piston **125** reaches top dead center. The exhaust valve **154** closes, ending the exhaust process. The transfer power valve **153** opens, which begins the next cycle of transferring a fresh charge to the power cylinder **120**.

TABLE 1

Valving and piston positions for the 5-valve engine (30 deg increments)							
crank pos.	compression			regenerator	power		
	piston	intake	transfer	exhaust	piston	transfer	exhaust
start	60bt	cl	op	cl	tdc	op	cl
30	30bt	cl	op	cl	30at	op	cl
60	tdc	cl	op	cl	60at	cl	cl
						Combustion	
90	30at	op	cl	cl	90at	cl	cl
120	60at	op	cl	cl	60bb	cl	cl
150	90at	op	cl	cl	30bb	cl	cl
180	60bb	op	cl	op	bdc	op	cl
						Blowdown	
210	30bb	op	cl	op	30ab	op	cl
240	bdc	cl	cl	op	60ab	op	cl
270	30ab	cl	cl	op	90ab	op	cl
300	60ab	cl	op	cl	60bt	cl	op
330	90ab	cl	op	cl	30bt	cl	op
360	60bt	cl	op	cl	tdc	op	cl

bt = before top dead center  
 at = after top dead center  
 bb = before bottom dead center  
 ab = after bottom dead center

7. ( $150^\circ$ ) Continuation of the expansion and intake processes.
8. ( $180^\circ$ ) Continuation of the intake process. The expansion process has ended and the regenerator exhaust valve **152** and the transfer power valve **153** open. This starts the blowdown process. Hot gases leave the power cylinder **120**, go through the regenerator **140** and through the exhaust valve **152** and out the exhaust manifold. In this process, the regenerator **140** picks up heat, which it imparts to the next charge of air. 55
9. ( $210^\circ$ ) Intake and blowdown processes continue.
10. ( $240^\circ$ ) Intake process ends, so intake valve **150** closes. Blowdown continues in the power cylinder **120**. 60
11. ( $270^\circ$ ) Compression process begins in the compression cylinder **110**. Blowdown continues. 65

Table 2 shows the valving for the engine with two regenerators. There is 1 intake valve **150**, and there are 2 sets of transfer compression valves **151a**, **151b**, exhaust valves **152a**, **152b** and transfer power valves **153a**, **153b**, accompanying the two regenerators **140a**, **140b** as shown in the top view of FIG. 3a. Thus, there are seven valves.—an intake valve and two transfer compression valves (one for each regenerator) on the compression head, a pair of exhaust valves on compression side of each regenerator, and two transfer power valves (one for each regenerator) on the power cylinder **120** head. The engine sequence in  $30^\circ$  increments is as follows:

1. Start: air is beginning to be transferred from the compression cylinder **110** to the power cylinder **120**. As it is transferred, it passes through the regenerator **140a**, which heats it up. To facilitate transfer, the compression piston **115** lags the power piston **125**. During transfer,



transfer compression valve **151a** on the compression head and transfer power valve **153a** on the power head are open; all other valves are closed.

2. (30°) Transfer continues.
3. (60°) Transfer ends. The amount of crank angle for the transfer is equal to the lag of the compression piston to the power piston. In this example, the lag was exactly 60°, but the exact amount of the lag can vary. This phase lag has an important effect, since it determines the compression ratio of the engine. At the end of transfer, the transfer power valve **153a** closes. This shuts off flow from the regenerator **140a** to the power cylinder **120**. The transfer compression valve **151a** remains open, starting the springback process.
4. (60°) Combustion. Fuel is sprayed by injector **160** into the power cylinder **120**, which fires. The air has picked up enough heat from the regenerator to ignite the fuel (>900° F.). In actual operation, the fuel would be sprayed slightly before this time, to allow time for the fuel to ignite.
5. (90°) The power cylinder **120** is on its expansion (power) process. The intake valve **151** opens, the transfer compression valve **151a** closes, and transfer compression valve **151b** opens. This starts the intake process.
6. (120°) Continuation of the expansion and intake process.
7. (150°) Continuation of the expansion and intake process.
8. (180°) Continuation of the intake process. The expansion process has ended and the exhaust valve **152a** and the transfer power valve **153a** open. This starts the exhaust process. Hot gases leave the power cylinder **120**, go through the regenerator **140a** and out the exhaust valve **152a**. In this process, the regenerator **140a** picks up heat.
9. (210°) Intake and exhaust processes continue.
10. (240°) Intake process ends, so intake valve **150** closes. Exhaust continues in the power cylinder **120**.
11. (270°) Compression process begins in the compression cylinder **110**. Exhaust through regenerator **140a** continues.
12. (300°) Compression and exhaust processes continue.
13. (330°) Compression and exhaust processes continue.
14. (360°) Power piston **125** reaches top dead center. The transfer power valve **153a** closes, ending the exhaust process through regenerator **140a**. The transfer power valve **153b** opens, which begins the next cycle of transferring a fresh charge to the power cylinder **120**.

This time, the charge moves through regenerator **140b**. The transfer compression valve **151b** is already open; all other valves are closed.

15. (390°) Transfer continues.
16. (420°) Transfer ends. At the end of transfer, the transfer power valve **153b** closes. This shuts off flow from the regenerator **140b** to the power cylinder **120**. The transfer compression valve **151b** remains open, starting the springback process.
17. (420°) Combustion. Fuel is sprayed into the power cylinder **120**, which fires. The air has picked up enough heat from the regenerator to ignite the fuel (>1000°F.). In actual operation, the fuel would be sprayed slightly before this time, to allow time for the fuel to ignite.
18. (450°) The power cylinder **120** is on its expansion (power) process, and the compression cylinder **110** is ending its springback process. The intake valve **150** opens, the transfer compression valve **151b** closes, and transfer compression valve **151a** opens. This starts the intake process.
19. (480°) Continuation of the expansion and intake processes.
20. (510°) Continuation of the expansion and intake processes.
21. (540°) Continuation of the intake process. The expansion process has ended and the exhaust valve **152b** and the transfer power valve **153b** open. This starts the exhaust process. Hot gases leave the power cylinder **120**, go through the regenerator **140b** and out the exhaust valve **152b**. In this process, the regenerator **140b** picks up heat.
22. (570°) Intake and exhaust processes continue.
23. (600°) Intake process ends, so intake valve **150** closes. Exhaust continues in the power cylinder **120**.
24. (630°) Compression process begins in the compression cylinder **110**. Exhaust through regenerator **140b** continues.
25. (660°) Compression and exhaust processes continue.
26. (690°) Compression and exhaust processes continue.
27. (720°) Power piston reaches top dead center. The transfer power valve **153b** closes, ending the exhaust process through regenerator **140b**. The transfer power valve **153a** opens, which begins the next cycle of transferring a fresh charge to the power cylinder **120**. This time, the charge moves through regenerator **140a**, which is where the cycle started. The transfer compression valve **151a** is already open; all other valves are closed. Cycle repeats.

TABLE 2

Valving and piston positions for the 7-valve engine (30 deg increments)									
crank	compression				regen1	regen2	power		
pos.	piston	intake	trn1	trn2	exh	exh	piston	trans1	trans2
start	60bt	cl	op	cl	cl	cl	tdc	op	cl
30	30bt	cl	op	cl	cl	cl	30at	op	cl
60	tdc	cl	op	cl	cl	cl	60at	cl	cl
								Combustion	
90	30at	op	cl	cl	cl	cl	90at	cl	cl
120	60at	op	cl	cl	cl	cl	60bb	cl	cl
150	90at	op	cl	cl	cl	cl	30bb	cl	cl
180	60bb	op	cl	cl	op	cl	bdc	op	cl



TABLE 2-continued

Valving and piston positions for the 7-valve engine (30 deg increments)									
crank	compression				regen1	regen2	power		
pos.	piston	intake	trn1	trn2	exh	exh	piston	trans1	trans2
									Blowdown
210	30bb	op	cl	cl	op	cl	30ab	op	cl
240	bdc	cl	cl	op	op	cl	60ab	op	cl
270	30ab	cl	cl	op	op	cl	90ab	op	cl
300	60ab	cl	cl	op	op	cl	60bt	op	cl
330	90ab	cl	cl	op	op	cl	30bt	op	cl
360	60bt	cl	cl	op	cl	cl	tdc	cl	op
390	30bt	cl	cl	op	cl	cl	30at	cl	op
420	tdc	cl	cl	op	cl	cl	60at	cl	cl
									Combustion
450	30at	op	cl	cl	cl	cl	90at	cl	cl
480	60at	op	cl	cl	cl	cl	60bb	cl	cl
510	90at	op	cl	cl	cl	cl	30bb	cl	cl
540	60bb	op	cl	cl	cl	op	bdc	cl	op
									Blowdown
570	30bb	op	cl	cl	cl	op	30ab	cl	op
600	bdc	cl	op	cl	cl	op	60ab	cl	op
630	30ab	cl	op	cl	cl	op	90ab	cl	op
660	60ab	cl	op	cl	cl	op	60bt	cl	op
690	90ab	cl	op	cl	cl	op	30bt	cl	op
720	60bt	cl	op	cl	cl	cl	tdc	op	cl

bt = before top dead center  
at = after top dead center  
bb = before bottom dead center  
ab = after bottom dead center

#### Fuel Addition

For any of the embodiments, fuel may be added at any one of the following places:

- During the intake stroke. The fuels added here would be gasoline or other spark-ignition fuels in place of water at **161**.
- During the transfer from the compression cylinder **110** to the power cylinder **120**. Because the air is hot after leaving the regenerator, the fuels added could be solid fuels such as charcoal which require gasification, or fuels which require reformation. Because the air is already compressed, these processes should proceed more rapidly, and the heat generated by these processes is not lost.
- In the power cylinder **120**. The fuel system described in section 3 was for Diesel fuel. There is the possibility of multi-fuel capability in this engine. Other fuels, such as gasoline or methane, may be added in the power cylinder **120**. The gases are very hot in the power cylinder **120**, which allows a multi-fuel capability.

Ignition is by two different processes. It can either be by spark ignition, if the fuel customarily is used in spark ignition engines (e.g. gasoline), or it can be by hot air if the fuel is customarily used in compression ignition engines (e.g. Diesel fuel). Note that in the 2nd case this is not a compression ignition engine; instead the air is sufficiently hot after leaving the regenerator to ignite the Diesel fuel. Thus, in this case it could be called a regenerator ignition engine.

In the case of spark ignition fuels, such as gasoline, ignition may be by spark ignition or by other means or by some combination thereof. This is particularly true if the air/fuel mixture is less than stoichiometric. Because the gases are so hot in the power cylinder **120** (over 1300 degrees F.), there is a possibility of either on very lean mixtures with gasoline. The flame speed increases with temperature, and there is less chance of flameout with the higher temperatures. Also, the temperature of the head and piston crown in the power cylinder **120** is above the self-ignition temperature of gasoline.

30

Heaters are placed in the regenerator, and glow plugs in the power cylinder **120**, to assist starting. Starting is dependent on heating regenerator **140** and the surfaces in the power cylinder **120** sufficiently so that the fuel ignites when diesel fuel is used. If fuel is being generated by a gasification process, then the regenerator **140** needs to be hot enough to generate the fuel. In the case of spark ignition fuels such as gasoline, the starting procedure will depend on the air/fuel ratio being used.

Because the objective of the regenerator is to capture as much heat as possible, it is believed that it would be better to not cool the valve in the exhaust cylinder. In order for the valve to live, this would require a less than stoichiometric mixture to be burned at all times in the power cylinder **120**. If a stoichiometric mixture is to be burned, the valve must be cooled. The cylinder will be cooled. The engine can either be air cooled or water cooled.

The major advantage of this engine is that its indicated thermal efficiency is projected to be over 50%, using realistic models of the engine processes and heat losses. The brake specific fuel consumption is projected to be 40% less than that of the best current diesels, and 50% less than that of the best current gasoline engines.

The various engines have different efficiencies. The four valve engine has a compression/transfer process which compresses hot exhaust gases, causing inefficiencies. Depending on the valve timing and other factors, here are the indicated efficiencies of the various engines:

4-valve	50-53%
5-valve	51-54%
7-valve	54-57%

Projected indicated mean effective pressure: approximately 127 psi.

The four valve is the least efficient of the three engines, but it is a much more buildable engine. The valving in the



five and seven valve engines is very complex. In addition, the five valve engine has the problem that not all of the exhaust gases pass through the regenerator, making it somewhat problematic for pollution control.

The seven valve embodiment has poor buildability due to its complex valving and higher cost cam design.

For these reasons, the four valve engine is generally considered as the preferred embodiment. This engine, because it will usually run a less than stoichiometric mixtures, has far fewer pollution problems than current engines. The presence of the hot regenerator allows for the use of catalysts to efficiently remove pollutants from the exhaust stream.

A great advantage of this engine over other engines is that if the catalyst is combined with the regenerator, the engine will not start unless the catalyst is hot. Thus, cold start pollution can be designed out of the engine.

A second advantage is that the regenerator can also be used as a filter. It can trap soot and other carbon particles. Because it is so hot, the regenerator will consume these particles, or the reverse flow will push them back into the power cylinder **120** to be burned.

Thus, the problem of soot in a diesel engine is reduced or eliminated. It is known that a filter can be put on a diesel engine to eliminate this pollution, but it must be cleaned, i.e. the particles burned off periodically. The filter in the regenerator will be so hot that it constantly cleans itself, and the heat from the particles is transferred into the power cylinder **120** on the next cycle.

The preceding efficiency calculations assume a regenerator consisting of 0.0044" diameter 18/8 stainless steel cylindrical wire perpendicular to the flow. Other regenerator options include, but are not limited to, steel wool (of the suitable grade and size) and mesh perpendicular to the flow. These systems have been developed for Sterling engines, and are quite efficient. A ceramic filter is preferably incorporated into the regenerator to eliminate particulate pollution, with the filter being hot enough to bum off soot. The filter was not included in the above calculations. Heat transfer between the wire and the hot gases was included, as well as the pressure drop cause by drag from the wires.

Nothing in this document is to be construed as being the only timing possible. This includes both the valve timing and the lag between compression piston and power piston. In use of the present engine, the events described should follow roughly the sequence laid out herein, but the actual optimal timing for any particular engine may differ substantially from those given in these examples.

Several simulations have been made concerning the relative size of the cylinders, especially for the four valve engine. It has generally been found that if the compression cylinder **110** is somewhat larger (approximately 30% larger bore, same stroke) than the power cylinder **120**, that the engine works best. The reasons for this are:

- a) The compression cylinder **110** pushes more air into the power cylinder **120**, increasing the pressure and the mp of the engine.
- b) The extra air also fills the regenerator and the passages. There is enough air to fill them and push air into the regenerator. The effect of the volume of the deadspace (regenerator, passages, and valve clearance) is minimized. Thus a realistic deadspace volume (i.e. a volume sufficient to allow relative easy manufacture of the engine) can be realized without sacrificing much power.
- c) During the compression/transfer process, hot gases are pushed from the power cylinder **120** to the compression

cylinder **110**. With a larger compression cylinder **110**, there is more room for these gases, thus the deleterious effects of this process are minimized.

It has been found through simulation, that it is better to ignite the mixture a few degrees before the transfer process is complete. This is for the following reasons:

- a) at this point, most of the mass of air has been transferred (90–95%);
- b) during the last few degrees, pressure is falling and temperature is dropping in the power cylinder **120**; (The compression piston has almost stopped, whereas the power piston is moving downward. The unfired gases in the power cylinder **120** are expanding and doing work on the power cylinder **120**.)
- c) thus, power is lost unless the cylinder is fired prior to the completion of the transfer process, i.e. before the compression piston reaches TDC;
- d) when the power cylinder **120** fires, the power transfer valve must close (It will be necessary to have a valve that automatically closes in response to the pressure wave from firing of the cylinder.); and
- e) as the compression piston completes its stroke, it either compresses even more gases into the regenerator and passages after firing, or the intake valve opens and gases escape up the intake manifold. Without the springback process, this would be very wasteful of energy. Thus, the springback process, by recapturing this energy, is integral to a high efficiency engine, as it allows optimal ignition timing.

FIG. **10** illustrates a schematic diagram of an embodiment of the invention wherein plural sets of pistons **115** and **125** are coupled to a common driveshaft **180**. This embodiment also includes a turbocharger or supercharger **165** compressing intake air to compression cylinders **110** that, in this example, have a bore about 30% larger than that of power cylinders **120**. Another shaft **170** can be used to help operate the compression pistons **115**. This is but one example of the many possible engine arrangements.

Although the invention has been described with respect to a few exemplary embodiments, numerous other modifications may be made without departing from the scope of the invention as defined by the claims. For instance, a turbocharger or supercharger may be used with this engine to increase the mean effective pressure and power output of the engine. Despite the fact that it would reduce efficiency, the engine of the present invention could be throttled. Additionally, it is obvious that an engine in accordance with the present invention can be produced with numerous pairs of cylinders attached to a common driveshaft and/or with advanced materials such as ceramics and composites and/or with advanced valving systems such as solenoid or direct actuated valves.

I claim:

1. An internal combustion engine, comprising:
  - a compression cylinder having an intake valve and at least one transfer compression valve;
  - a compression piston mounted for reciprocation inside said compression cylinder;
  - a power cylinder having at least one transfer power valve;
  - a power piston mounted for reciprocation inside said power cylinder;
  - a passage connected between each transfer compression valve and transfer power valve, said passage including a regenerator and a regenerator exhaust valve between said transfer compression valve and said regenerator.



2. The internal combustion engine of claim 1, wherein the engine comprises a single transfer compression valve, a single transfer power valve, a single passage, and a single regenerator.

3. The internal combustion engine of claim 2, wherein the engine further comprises a power exhaust valve in said power cylinder.

4. The internal combustion engine of claim 1, wherein the engine comprises a pair of transfer compression valves, a pair of transfer power valves, a pair of passages, and a pair of regenerators.

5. The internal combustion engine of claim 1, further comprising means for injecting water into said compression cylinder.

6. The internal combustion engine of claim 1, further comprising means for injecting fuel into said compression cylinder.

7. The internal combustion engine of claim 1, further comprising means for injecting fuel into said power cylinder.

8. The internal combustion engine of claim 1, further comprising means connecting said compression piston and said power piston to rotate between 30–90 degrees out of phase.

9. The internal combustion engine of claim 8, wherein said compression piston and said power piston rotate approximately 60 degrees out of phase.

10. The internal combustion engine of claim 1, wherein said compression cylinder has an approximately 30% larger bore and the same stroke as said power cylinder.

11. The internal combustion engine of claim 1, further comprising a turbocharger or supercharger for compressing intake air.

12. The internal combustion engine of claim 1, further comprising a driveshaft for connecting multiple pairs of pistons.

13. An internal combustion engine process with thermal efficiency greater than 50%, comprising:

drawing air through an intake valve into a compression cylinder;

closing said intake valve and compressing said air with a compression piston;

opening at least one transfer compression valve to pass compressed air through a regenerator and a transfer power valve to supply heated compressed air to a power cylinder;

combusting fuel in said heated compressed air to drive said power piston; and

opening said transfer power valve and to pass exhaust gas through said regenerator and a regenerator exhaust valve to reclaim exhaust gas heat.

14. The internal combustion engine process of claim 13, wherein said air is passed through a single transfer compression valve, a single transfer power valve, a single passage, and a single regenerator in a two-stroke cycle process.

15. The internal combustion engine process of claim 14, further comprising passing exhaust gasses through a power exhaust valve on said power cylinder.

16. The internal combustion engine process of claim 13, wherein said air is alternately passed through a pair of transfer compression valves, a pair of transfer power valves, a pair of passages, and a pair of regenerators in a four-stroke cycle process.

17. The internal combustion engine process of claim 13, wherein the compression of air in said compression cylinder is nearly isothermal by the addition of water or fuel to said air.

18. The internal combustion engine process of claim 13, wherein fuel is injected into said air in compression cylinder or said power cylinder and combustion is initiated by a method selected from the group consisting of hot air ignition, spark ignition, or a combination thereof.

19. The internal combustion engine process of claim 13, further comprising a springback process for said compression cylinder wherein said transfer compression valve remains open to allow compressed air in said regenerator and passage to move said compression piston until atmospheric pressure is reached, at which point said transfer compression valve closes and said intake valve opens.

20. The internal combustion engine process of claim 13, further comprising connecting said compression piston and said power piston to rotate between 30–90 degrees out of phase.

21. The internal combustion engine process of claim 20, wherein said compression piston and said power piston rotate approximately 60 degrees out of phase.

22. The internal combustion engine process of claim 13, wherein fuel is supplied by a method from the group consisting of spark-ignition fuel added during an intake stroke, fuels requiring gasification or reformation during transfer from compression to power cylinders, hot-air ignition fuel injection in the power cylinder, and combinations thereof.

23. The internal combustion engine process of claim 13, wherein power is boosted by use of a turbocharger or supercharger.

24. The internal combustion engine process of claim 13, wherein multiple pairs of pistons are attached to a common driveshaft.

\* \* \* \* \*