



US006333922B1

(12) **United States Patent**  
**Campanella**

(10) **Patent No.: US 6,333,922 B1**  
(45) **Date of Patent: Dec. 25, 2001**

(54) **SATELLITE PAYLOAD PROCESSING SYSTEM FOR SWITCHING UPLINK SIGNALS TO TIME DIVISION MULTIPLEXED DOWNLINK SIGNALS**

(75) Inventor: **S. Joseph Campanella**, Gaithersburg, MD (US)

(73) Assignee: **WorldSpace, Inc.**, Washington, DC (US)

(\* ) Notice: Subject to any disclaimer, the term of this patent is extended or adjusted under 35 U.S.C. 154(b) by 0 days.

(21) Appl. No.: **09/250,263**

(22) Filed: **Feb. 16, 1999**

**Related U.S. Application Data**

(63) Continuation of application No. 08/746,070, filed on Nov. 5, 1996, now abandoned.

(51) Int. Cl.<sup>7</sup> ..... **H04B 7/204; H04L 12/54**

(52) U.S. Cl. .... **370/319; 370/429; 370/474**

(58) Field of Search ..... 370/316, 319, 370/320, 321, 323, 324, 325, 326, 465, 466, 470, 471, 474, 476, 478, 337, 343, 344, 345, 347, 348, 349, 412, 428, 429

(56) **References Cited**

**U.S. PATENT DOCUMENTS**

4,199,660	*	4/1980	Dill et al. ....	370/307
4,381,562	*	4/1983	Acampora ....	370/323
4,410,980	*	10/1983	Takasaki et al. ....	370/505
4,425,639		1/1984	Acampora et al. ....	370/50
4,660,196		4/1987	Gray et al. ....	370/109
4,873,684	*	10/1989	Kobayashi et al. ....	370/506
4,901,310		2/1990	Ichiyoshi ....	370/75
4,905,226	*	2/1990	Kobayashi ....	370/378
4,928,272	*	5/1990	Ohue ....	370/307
4,931,802		6/1990	Assal et al. ....	342/356
5,128,929	*	7/1992	Kobayashi ....	370/378
5,274,627	*	12/1993	Santis ....	370/307

5,283,780		2/1994	Schuchman et al. ....	370/50
5,299,192	*	3/1994	Guo et al. ....	370/210
5,303,393		4/1994	Noreen et al. ....	455/3.2
5,347,548		9/1994	Messerges et al. ....	375/116
5,416,774		5/1995	Shigematsu et al. ....	370/69.1
5,455,823		10/1995	Noreen et al. ....	670/50
5,473,601		12/1995	Rosen et al. ....	370/50
5,550,812		8/1996	Philips ....	379/19
5,625,624	*	4/1997	Rosen et al. ....	370/307
5,689,245		11/1997	Noreen et al. ....	340/825.49

**OTHER PUBLICATIONS**

“Communications Satellites: Orbiting int the '90s”, Aug. 1990, *IEEE Spectrum*, pp. 49–52.

“WorldSpace: The First DAB Satellite Service for the World”, Fournie et al., Oct. 10, 1995, pp. 1–7.

“Digital Audio Broadcasting: High Grade Service Quality Through On-Board Processing Techniques”, Losquadro, G. (1995, John Wiley & Sons, Ltd.).

\* cited by examiner

*Primary Examiner*—Kwang B. Yao

(74) *Attorney, Agent, or Firm*—Roylance, Abrams, Berdo & Goodman

(57) **ABSTRACT**

An apparatus for switching symbols in parallel broadcast channels to time division multiplexed data streams comprises first and second ping-pong buffers. The first ping-pong buffer is configured to store a first plurality of the parallel broadcast channels therein. The second ping-pong buffer is operable to store a second plurality of the broadcast channels therein. The second plurality of broadcast channels arrive at the second ping-pong buffer prior to the arrival of the first plurality of broadcast channels at the first ping pong buffer. The apparatus also comprises a routing switch connected to the outputs of the first and second ping-pong buffers, and a first frame assembler connected to the routing switch. The routing switch controls the writing of the contents of the second ping-pong buffer to the first frame assembler.

**14 Claims, 12 Drawing Sheets**

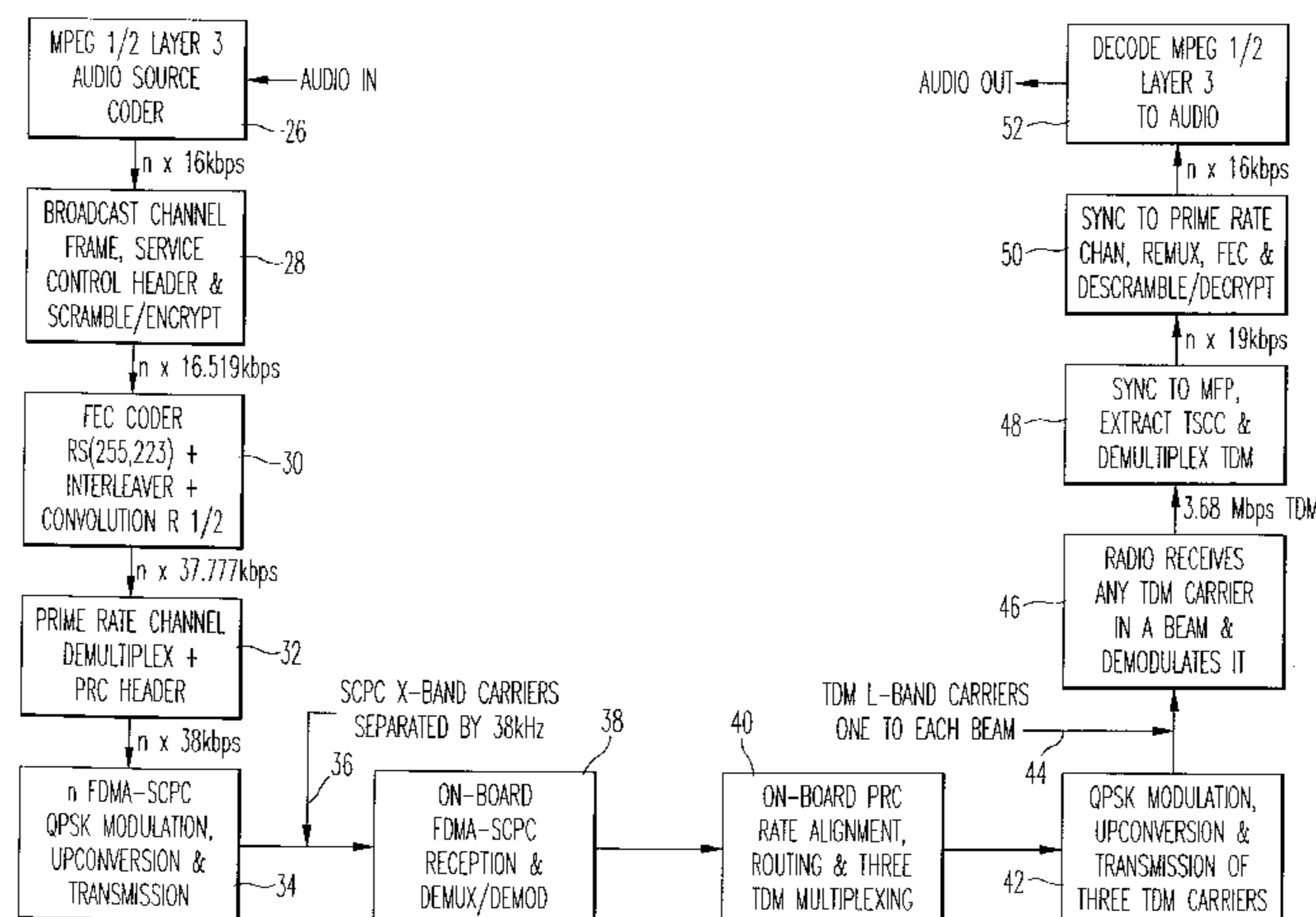

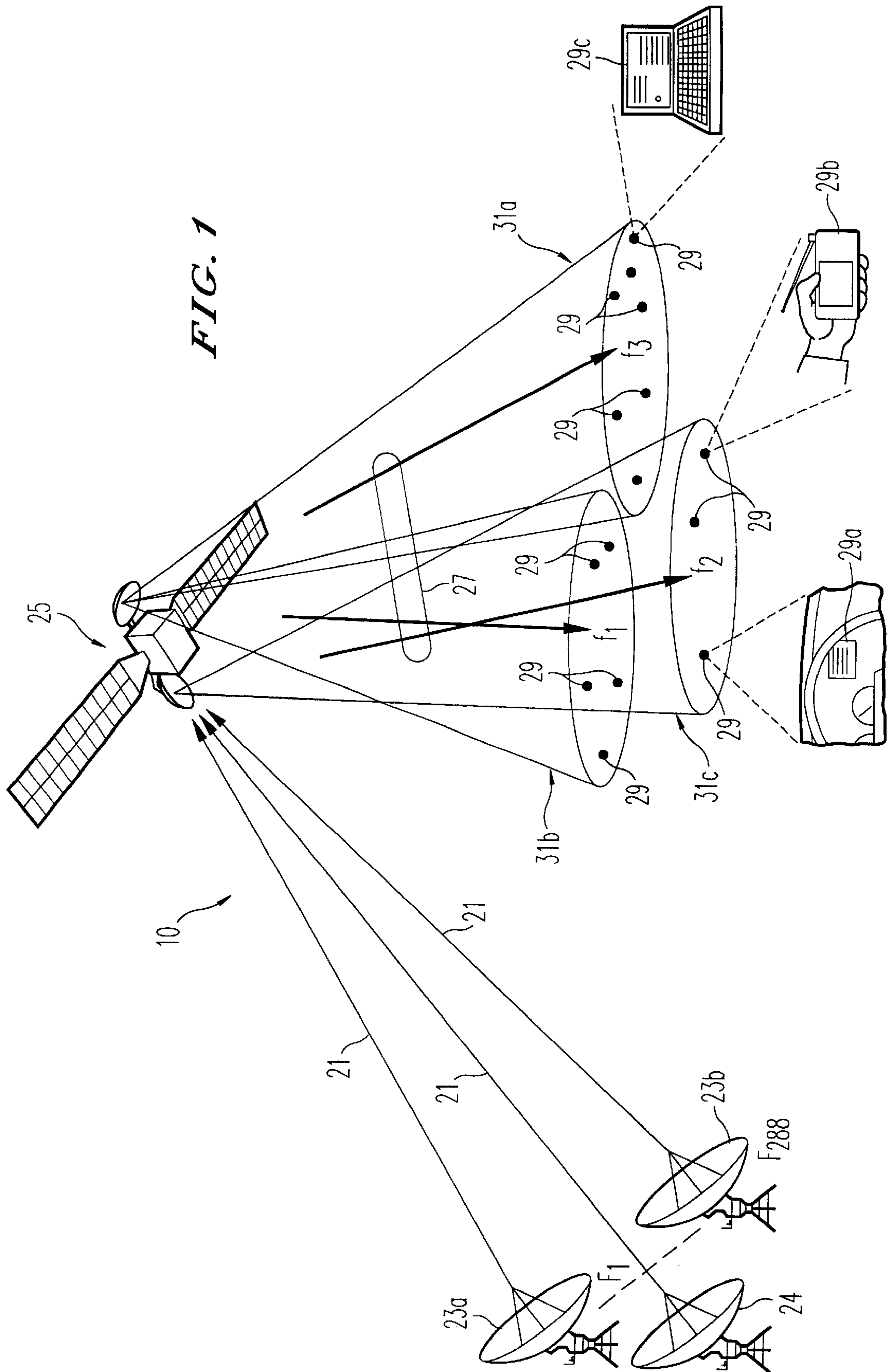

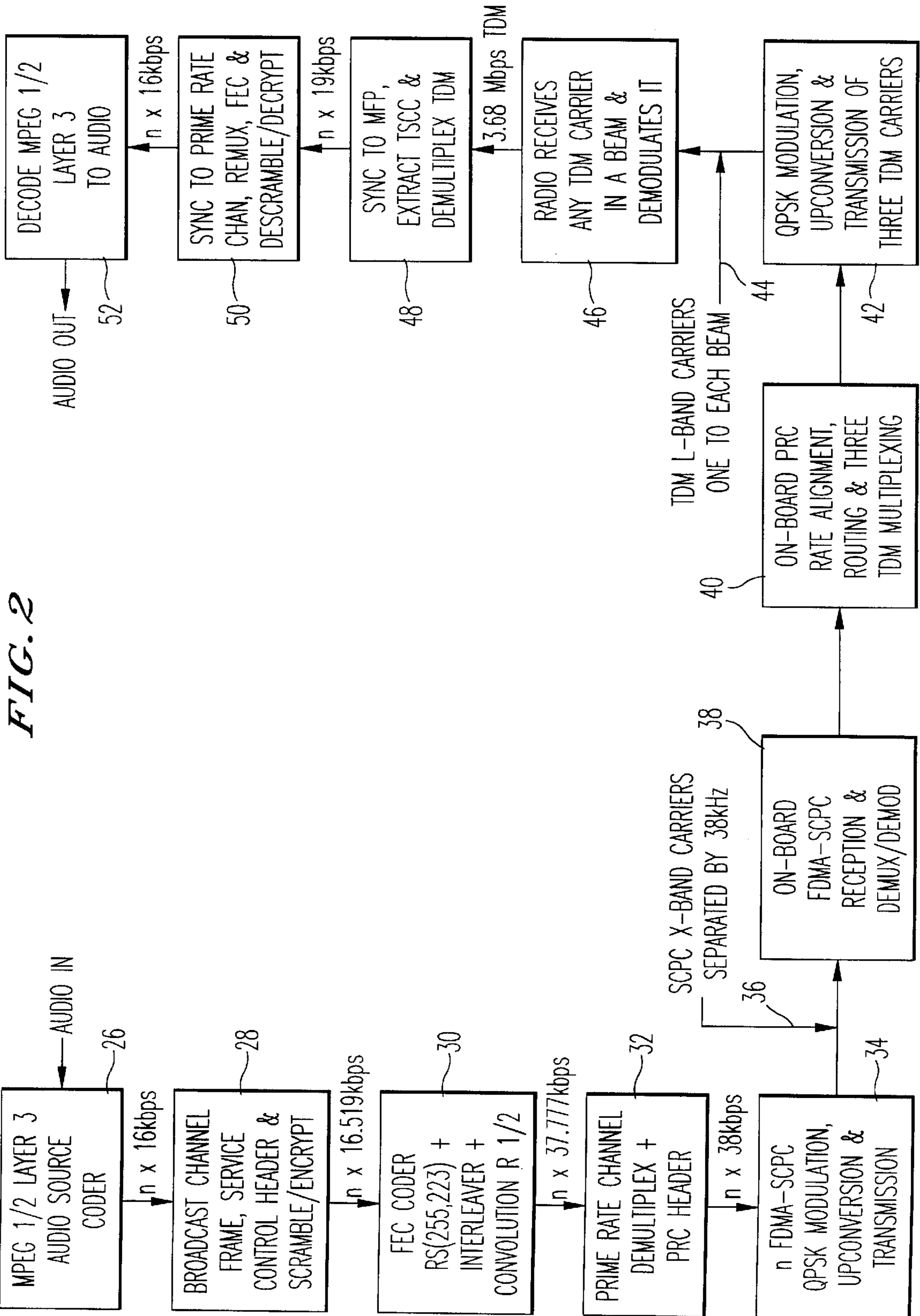

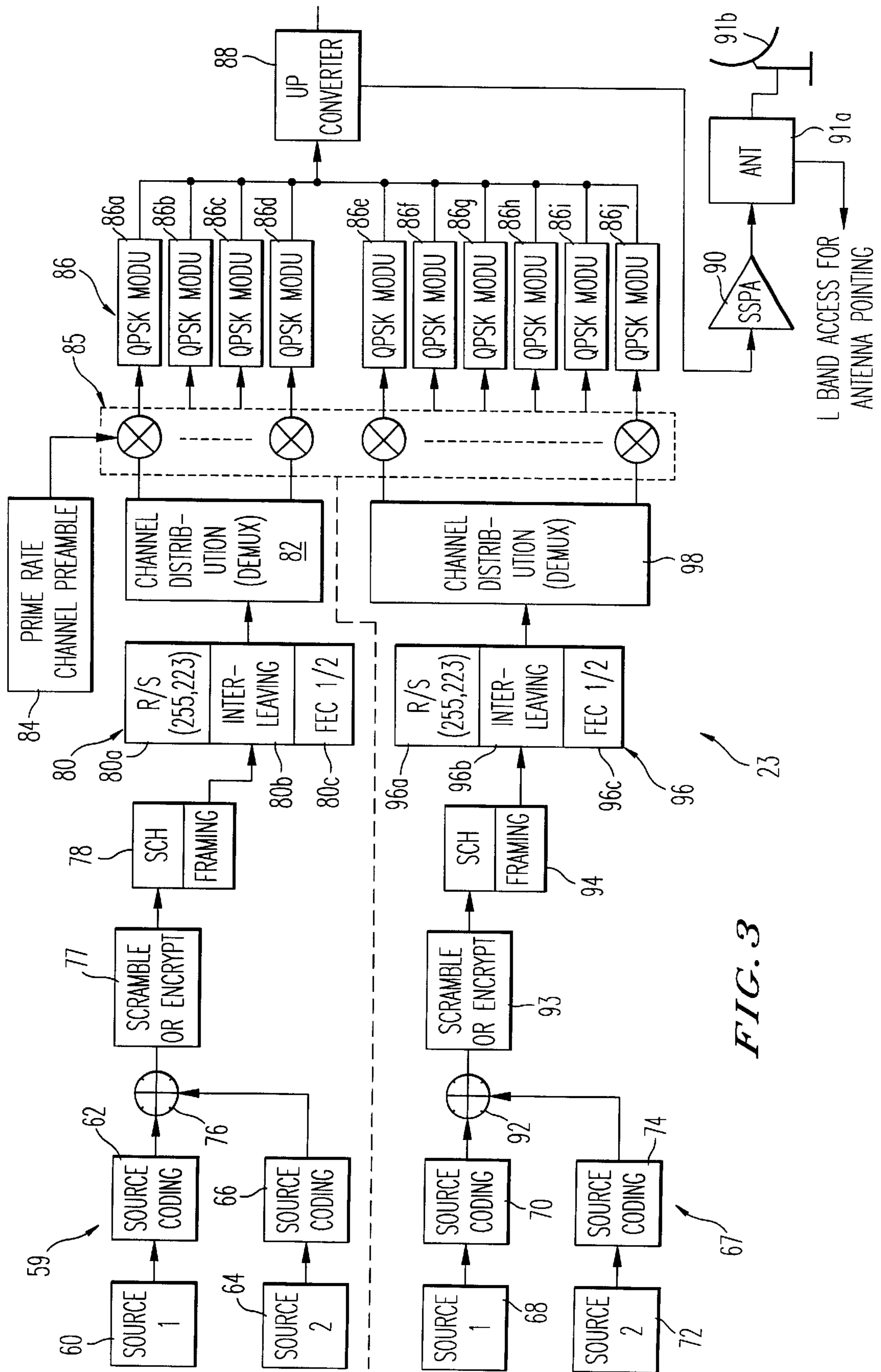

FIG. 3

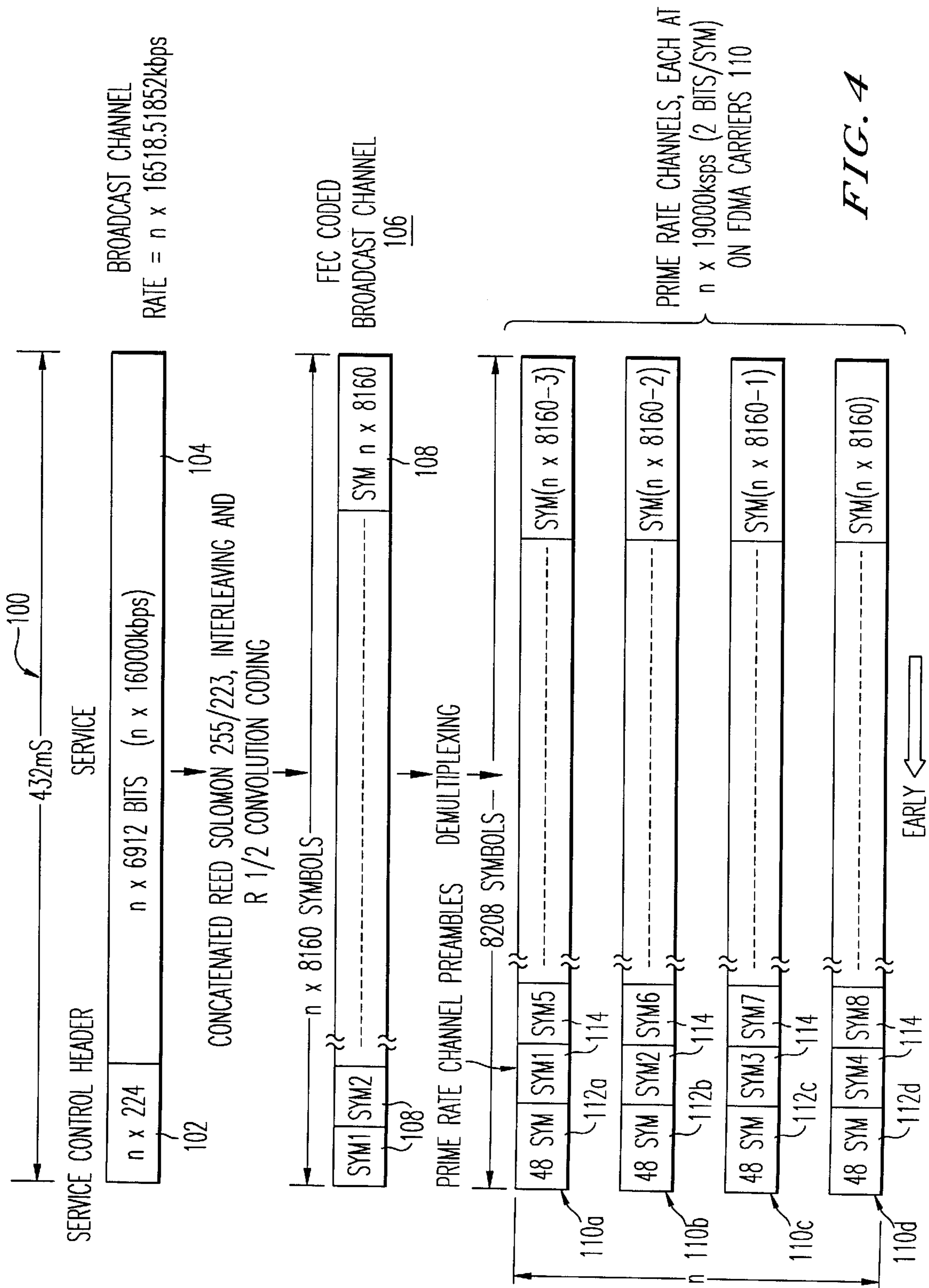

FIG. 4

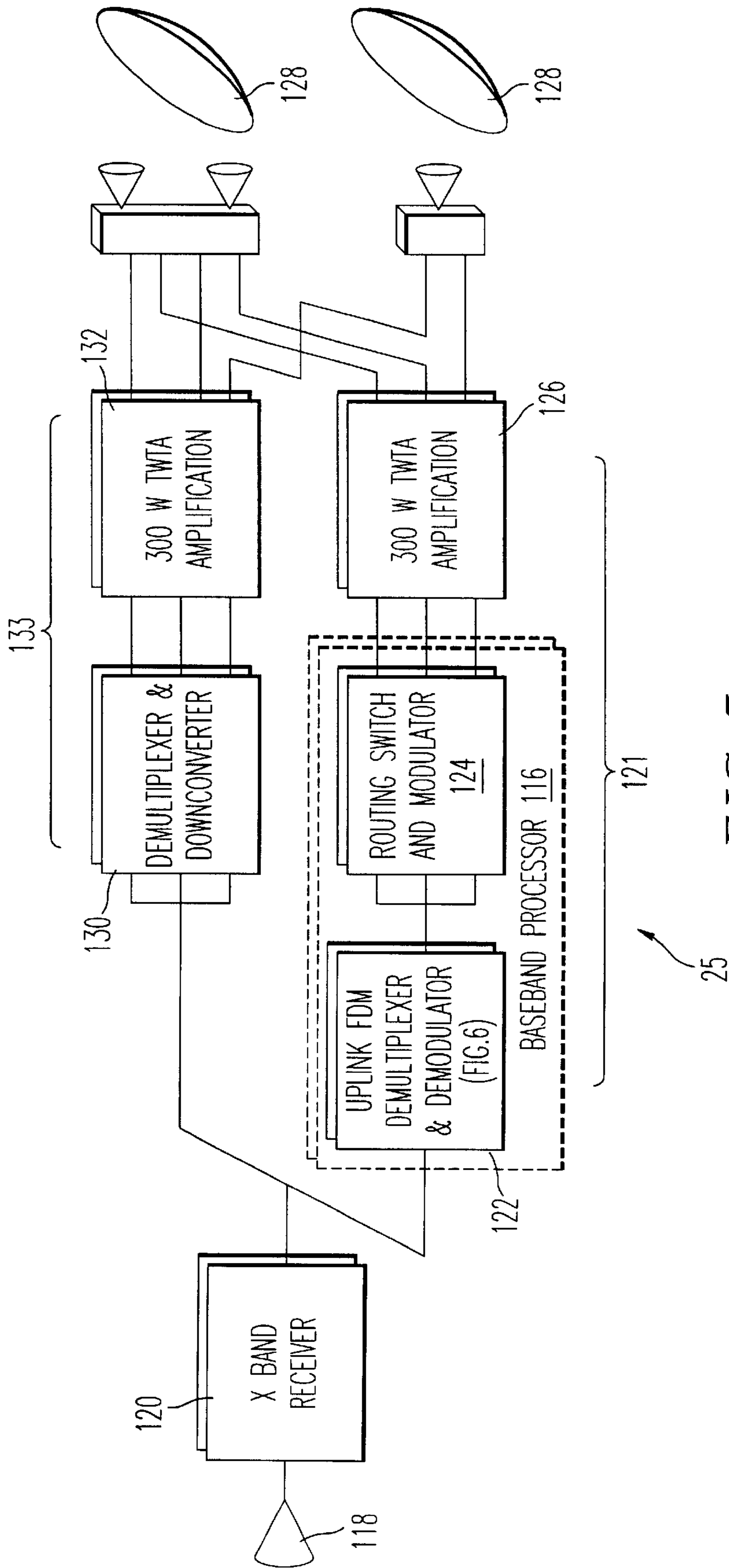

FIG. 5

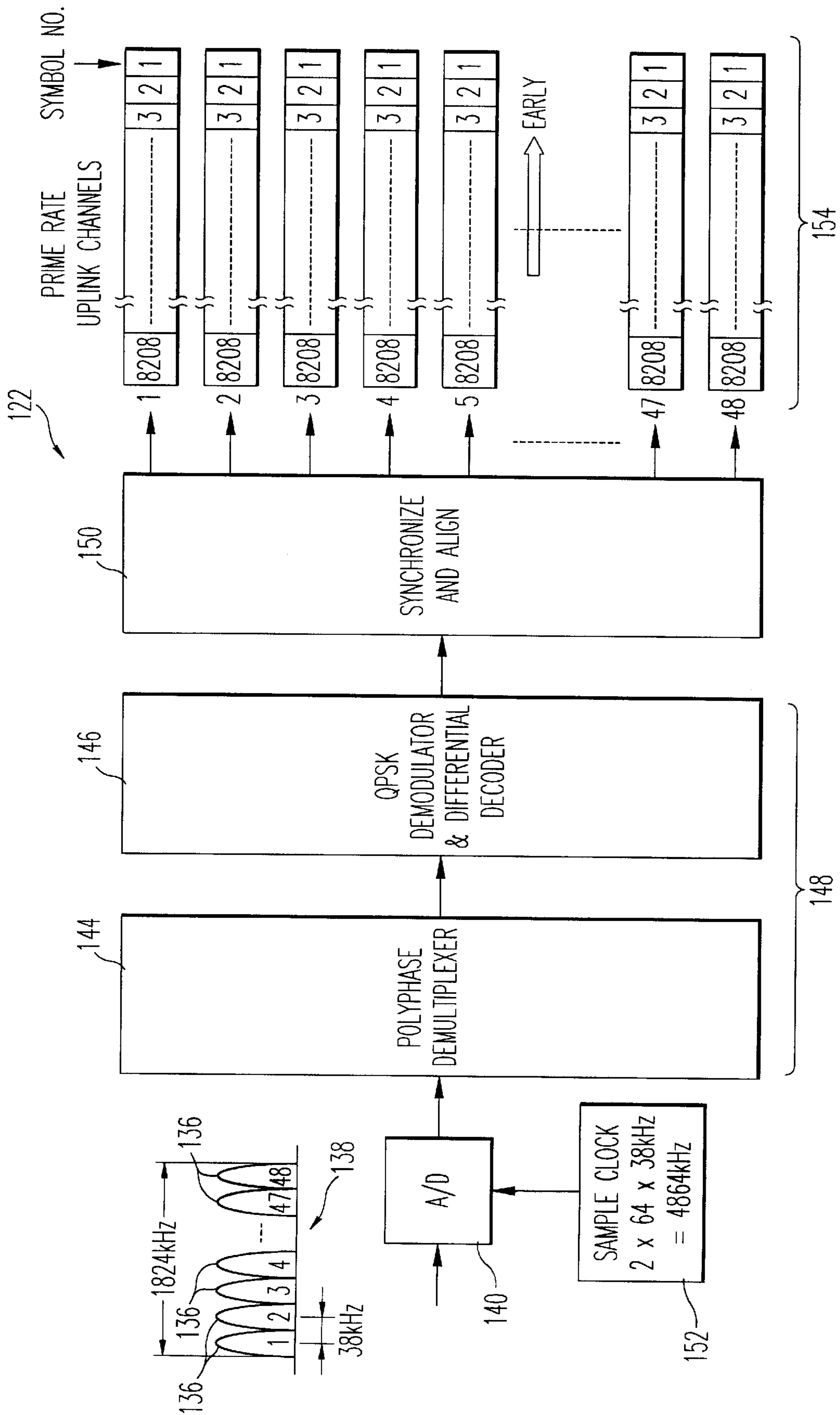

FIG. 6

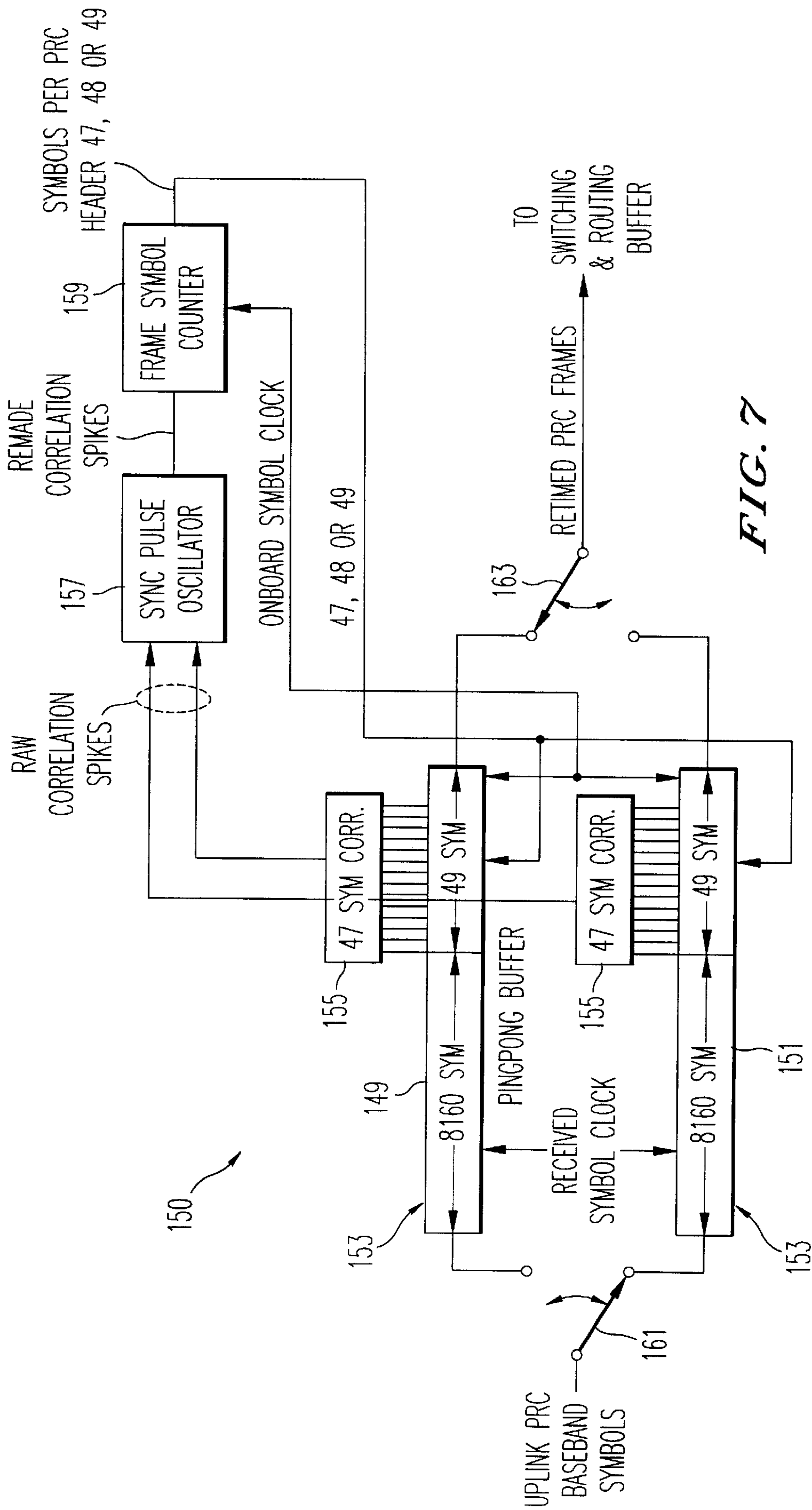

FIG. 7



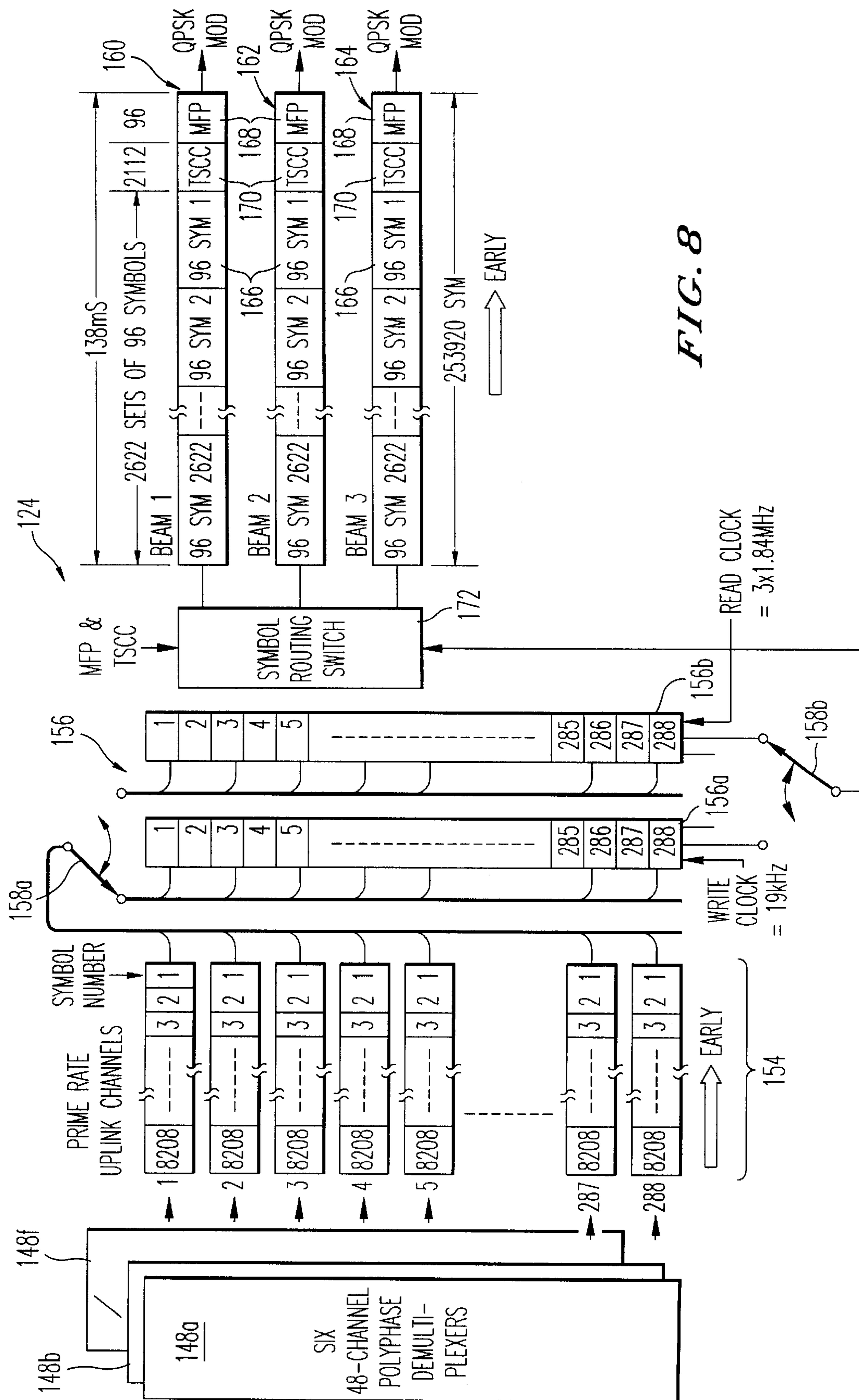

FIG. 8

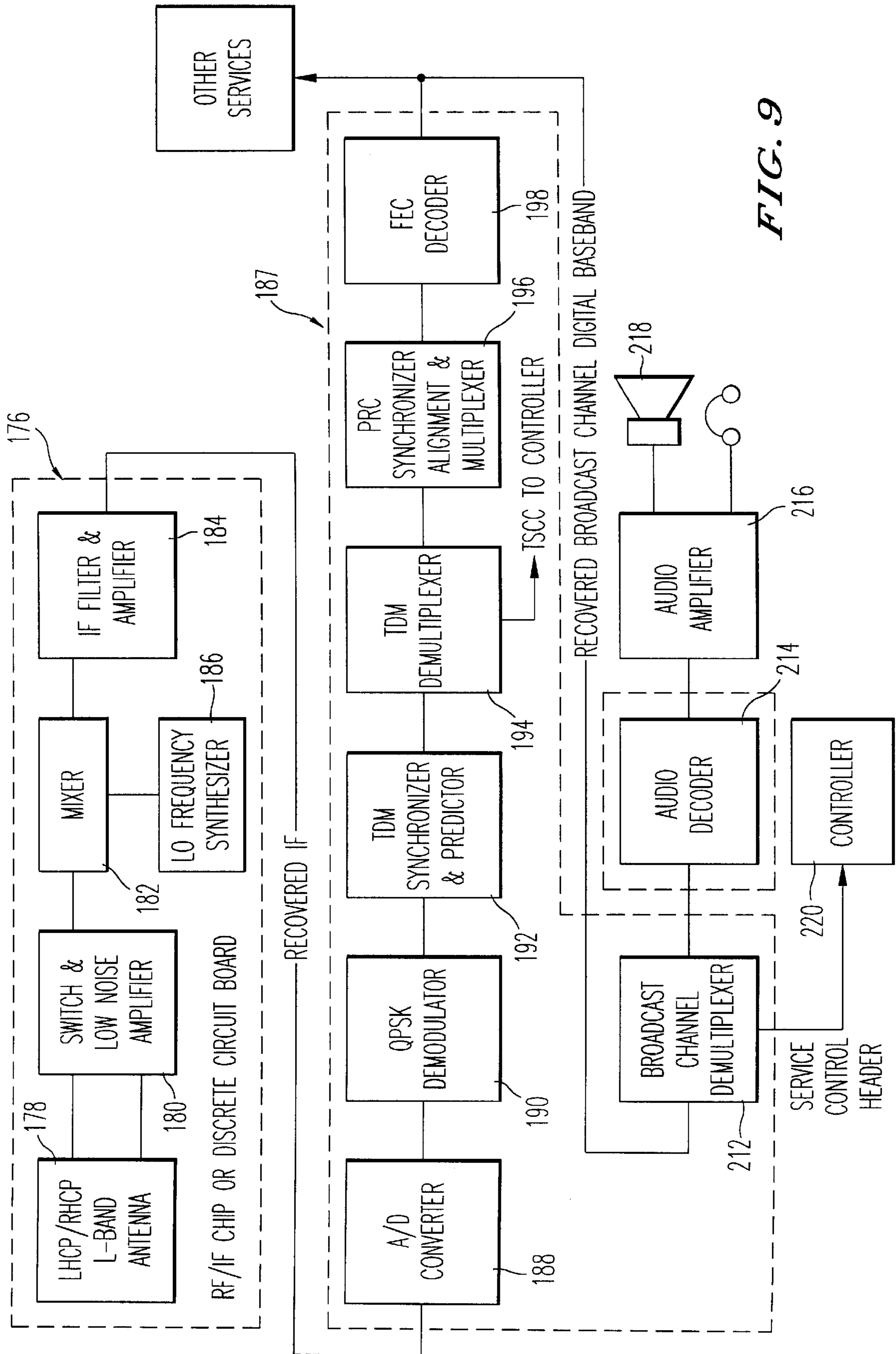

FIG. 9

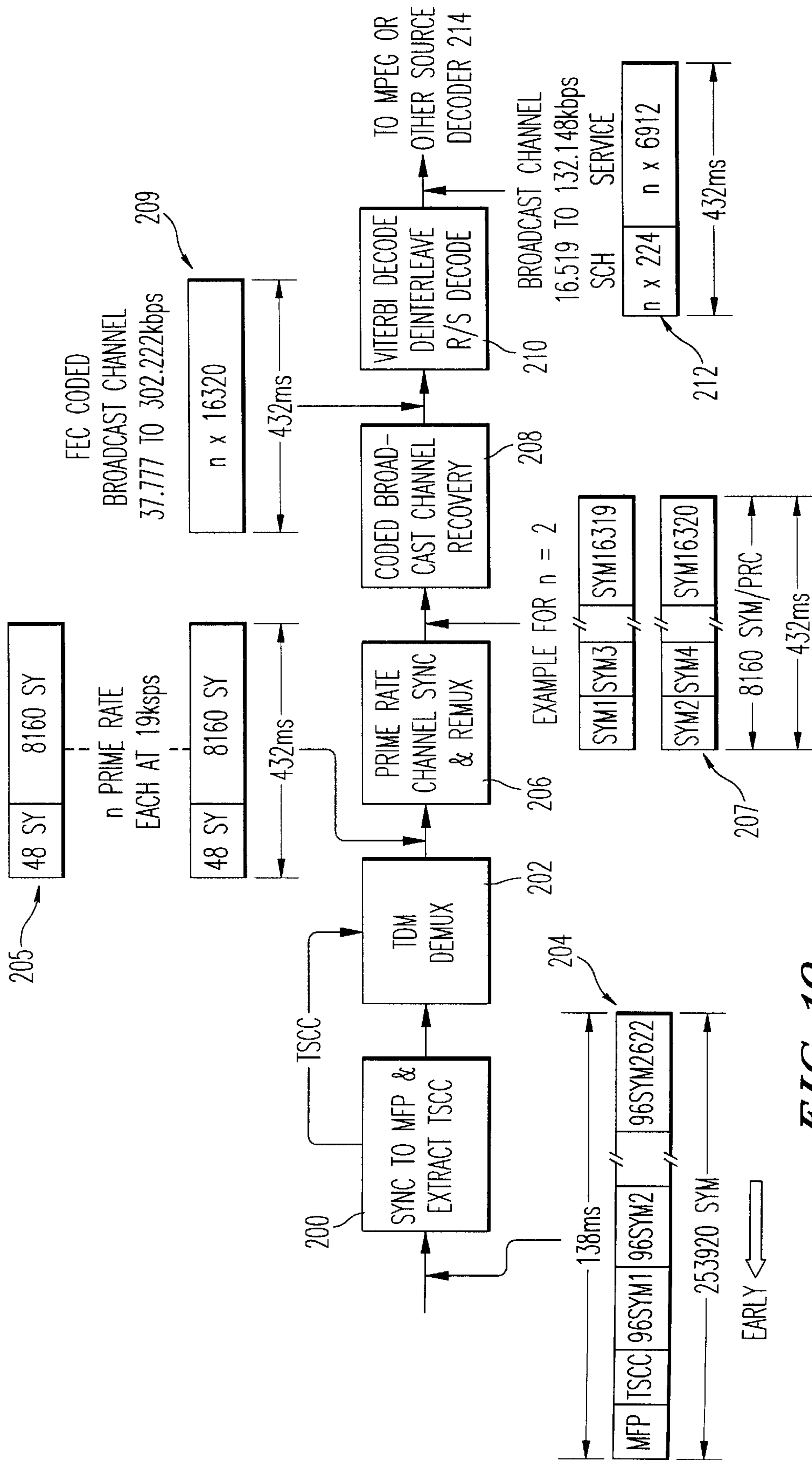

FIG. 10

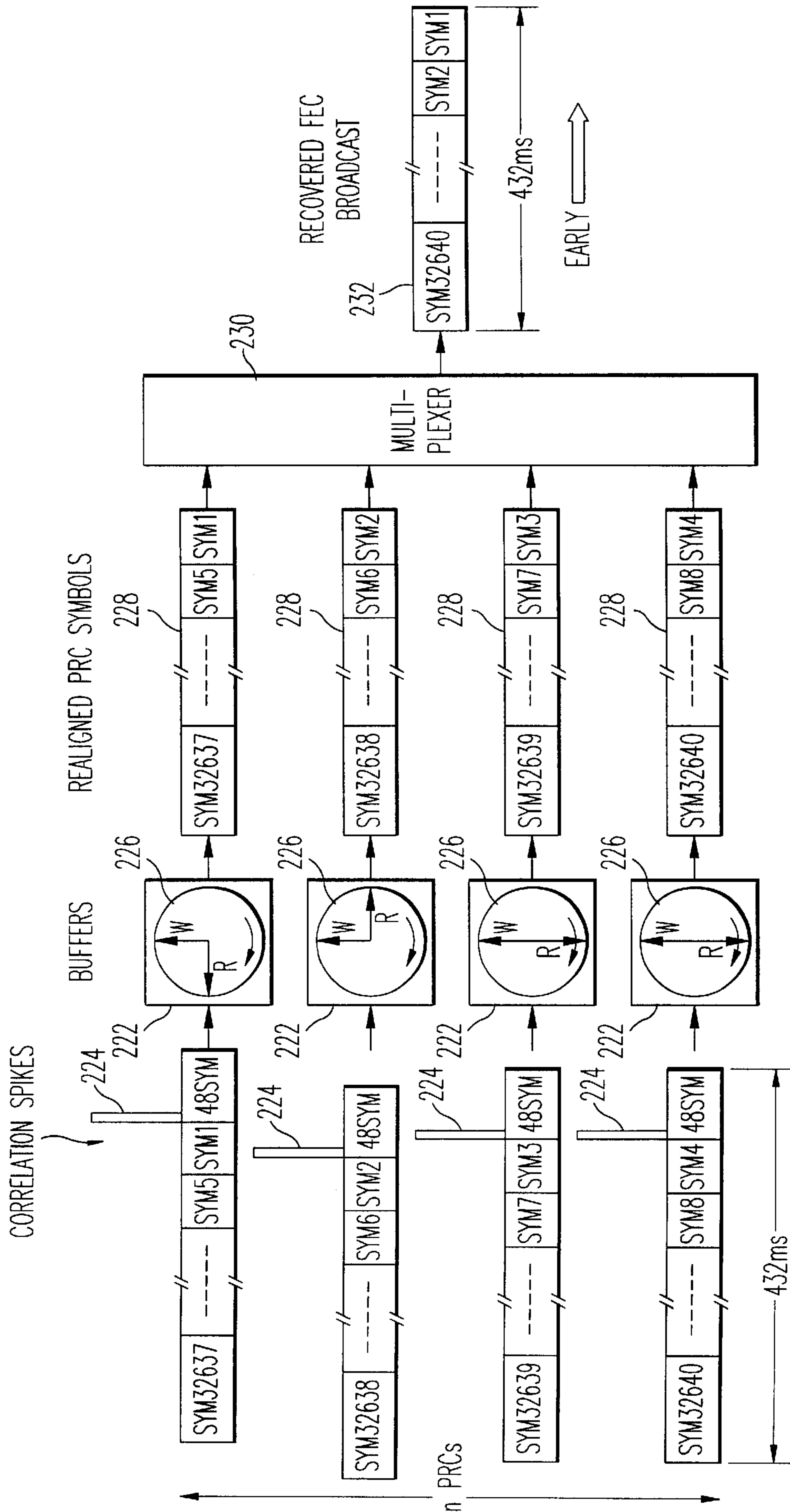

FIG. 11

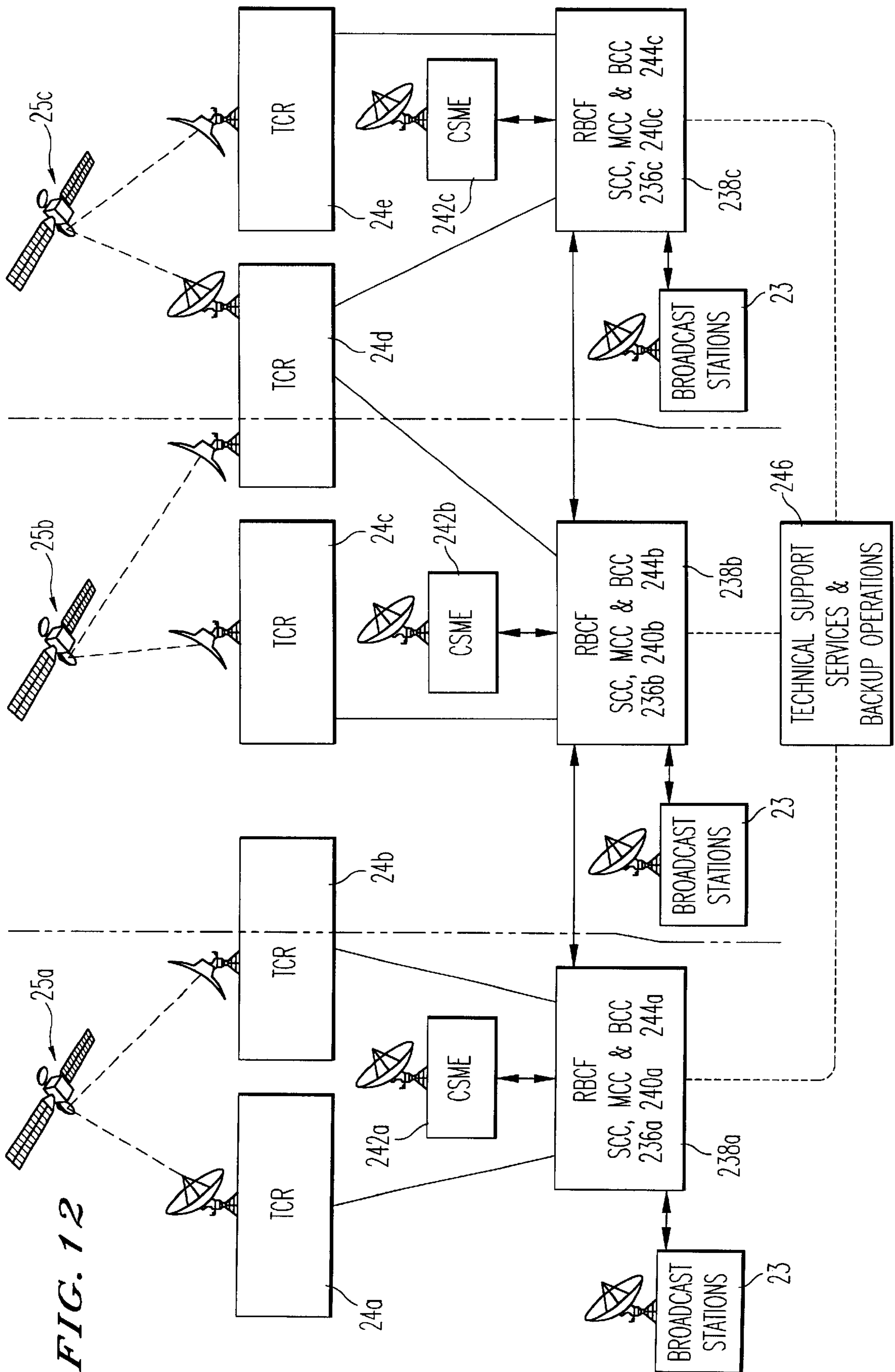

FIG. 12

**SATELLITE PAYLOAD PROCESSING  
SYSTEM FOR SWITCHING UPLINK  
SIGNALS TO TIME DIVISION  
MULTIPLEXED DOWNLINK SIGNALS**

This application is a continuation of U.S. application Ser. No. 08/746,070, filed Nov. 5, 1996 now abandoned.

**CROSS REFERENCE TO RELATED  
APPLICATIONS**

Related subject matter is disclosed and claimed in co-pending U.S. patent application Ser. No. 08/569,346, filed by S. Joseph Campanella on Dec. 8, 1995; in co-pending U.S. Patent Application of Robert L. Johnstone and S. Joseph Campanella, filed on Nov. 5, 1996 and entitled "System for Providing Location-Specific Data to a User" U.S. Pat. No. 5,898,680 ; in co-pending U.S. Patent Application of S. Joseph Campanella, filed on Nov. 5, 1996 and entitled "Direct Radio Broadcast Receiver Providing Frame Synchronization and Correlation for Time Division Multiplexed Transmission" U.S. Pat. No. 5,867,490 U.S. Patent Application of S. Joseph Campanella, filed on Nov. 5, 1996 and entitled "Direct Radio Broadcast Receiver for Time Division Multiplexed Transmissions" U.S. Pat. No. 5,870,390 U.S. Patent Application of S. Joseph Campanella, filed on Nov. 5, 1996 and entitled "System for Formatting Broadcast Data for Satellite Transmission and Radio Reception" U.S. Pat. No. 5,864,546 in co-pending U.S. Patent Application of S. Joseph Gampanella et al, filed on Nov. 5, 1996 and entitled "System for Managing Space Segment Usage Among Broadcast Service Providers" U.S. Pat. No. 6,115,366 U.S. Patent Application of S. Joseph Campanella, filed on Nov. 5, 1996 and entitled "Satellite Payload Processing System Using Polyphase Demultiplexing and Quadrature Phase Shift Keying Demodulation" Ser. No. 08/746,071; and in co-pending U.S. Patent Application of S. Joseph Campanella, filed on Nov. 5, 1996 and entitled "Satellite Payload Processing System Providing On-Board Rate Alignment" U.S. Pat. No. 6,108,319; all of said applications being expressly incorporated herein by reference.

**FIELD OF INVENTION**

This invention relates to satellite payload signal processing for switching symbols in parallel uplink channels to time division multiplexed downlink carriers.

**BACKGROUND OF THE INVENTION**

There presently exists a population of over 4 billion people that are generally dissatisfied and underserved by the poor sound quality of short-wave radio broadcasts, or the coverage limitations of amplitude modulation (AM) band and frequency modulation (FM) band terrestrial radio broadcast systems. This population is primarily located in Africa, Central and South America, and Asia. A need therefore exists for a satellite-based direct radio broadcast system to transmit signals such as audio, data and images to low-cost consumer receivers.

A number of satellite communications networks have been developed for commercial and military applications. These satellite communications systems, however, have not addressed the need to provide multiple, independent broadcast service providers with flexible and economical access to a space segment, nor consumers' need to receive high quality radio signals using low-cost consumer radio receiver units. A need therefore exists for providing service providers with direct access to a satellite and choices as to the amount

of space segment that's purchased and used. In addition, a need exists for a low-cost radio receiver unit capable of receiving time division multiplexed downlink bit stream.

**SUMMARY OF THE INVENTION**

In accordance with an aspect of the present invention, an apparatus for switching symbols in parallel broadcast channels to time division multiplexed data streams comprises first and second ping-pong buffers. The first ping-pong buffer is configured to store a first plurality of the parallel broadcast channels therein. The second ping-pong buffer is operable to store a second plurality of the broadcast channels therein. The second plurality of broadcast channels arrive at the second ping-pong buffer prior to the arrival of the first plurality of broadcast channels at the first ping-pong buffer. The apparatus also comprises a routing switch connected to the outputs of the first and second ping-pong buffers, and a first frame assembler connected to the routing switch. The routing switch controls the writing of the contents of the second ping-pong buffer to the first frame assembler.

In accordance with another aspect of the invention, the contents of ping-pong buffer can be switched to corresponding slots in two or more frame assemblers.

**A BRIEF DESCRIPTION OF THE DRAWINGS**

These and other features and advantages of the present invention will be more readily comprehended from the following detailed description when read in connection with the appended drawings, which form a part of this original disclosure, and wherein:

FIG. 1 is a schematic diagram of a satellite direct broadcast system constructed in accordance with an embodiment of the present invention;

FIG. 2 is a flow chart depicting the sequence of operations for end-to-end signal processing in the system depicted in FIG. 1 in accordance with an embodiment of the present invention;

FIG. 3 is a schematic block diagram of a broadcast earth station constructed in accordance with an embodiment of the present invention;

FIG. 4 is a schematic diagram illustrating broadcast segment multiplexing in accordance with an embodiment of the present invention;

FIG. 5 is a schematic block diagram of an on-board processing payload for a satellite in accordance with an embodiment of the present invention;

FIG. 6 is a schematic diagram illustrating on-board satellite demultiplexing and demodulation processing in accordance with an embodiment of the present invention;

FIG. 7 is a schematic diagram illustrating on-board satellite rate alignment processing in accordance with an embodiment of the present invention;

FIG. 8 is a schematic diagram illustrating on-board satellite switching and time division multiplexing operations in accordance with an embodiment of the present invention;

FIG. 9 is a schematic block diagram of a radio receiver for use in the system depicted in FIG. 1 and constructed in accordance with an embodiment of the present invention;

FIG. 10 is a schematic diagram illustrating receiver synchronization and demultiplexing operations in accordance with an embodiment of the present invention;

FIG. 11 is a schematic diagram illustrating synchronization and multiplexing operations for recovering coded broadcast channels at a receiver in accordance with an embodiment of the present invention; and

FIG. 12 is a schematic diagram of a system for managing satellite and broadcast stations in accordance with an embodiment of the present invention.

#### DETAILED DESCRIPTION OF THE PREFERRED EMBODIMENTS

##### Overview

In accordance with the present invention, a satellite-based radio broadcast system 10 is provided to broadcast programs via a satellite 25 from a number of different broadcast stations 23a and 23b (hereinafter referred to generally as 23), as shown in FIG. 1. Users are provided with radio receivers, indicated generally at 29, which are designed to receive one or more time division multiplexed (TDM) L-band carriers 27 downlinked from the satellite 25 that are modulated at 1.86 Megasymbols per second (Msym/s). The user radios 29 are designed to demodulate and demultiplex the TDM carrier to recover bits that constitute the digital information content or program transmitted on broadcast channels from the broadcast stations 23. In accordance with an embodiment of the invention, the broadcast stations 23 and the satellite 25 are configured to format uplink and downlink signals to allow for improved reception of broadcast programs using relatively low cost radio receivers. A radio receiver can be a mobile unit 29a mounted in a transportation vehicle, for example, a hand-held unit 28b or a processing terminal 29c with a display.

Although only one satellite 25 is shown in FIG. 1 for illustrative purposes, the system 10 preferably comprises three geostationary satellites 25a, 25b and 25c (FIG. 12) configured to use frequency bands of 1467 to 1492 Megahertz (MHz) which has been allocated for broadcasting satellite service (BSS) direct audio broadcast (DAB). The broadcast stations 23 preferably use feeder uplinks 21 in the X-band, that is from 7050 to 7075 Mhz. Each satellite 25 is preferably configured to operate three downlink spot beams indicated at 31a, 31b and 31c. Each beam covers approximately 14 million square kilometers within power distribution contours that are four decibels (dB) down from beam center and 28 million square kilometers within contours that are eight dB down. The beam center margin can be 14 dB based on a receiver gain-to-temperature ratio of -13 dB/K.

With continued reference to FIG. 1, the uplink signals 21 generated from the broadcast stations 23 are modulated in frequency division multiple access (FDMA) channels from the ground stations 23 which are preferably located within the terrestrial visibility of the satellite 25. Each broadcast station 23 preferably has the ability to uplink directly from its own facilities to one of the satellites and to place one or more 16 kilobit per second (kbps) prime rate increments on a single carrier. Use of FDMA channels for uplink allows for a significant amount of flexibility for sharing the space segment among multiple independent broadcast stations 23 and significantly reduces the power and hence the cost of the uplink earth stations 23. Prime rate increments (PRIs) of 16 kilobits per second (kbps) are preferably the most fundamental building block or rudimentary unit used in the system 10 for channel size and can be combined to achieve higher bit rates. For example, PRIs can be combined to create program channels with bit rates up to 128 kbps for near compact disc quality sound or multimedia broadcast programs comprising image data, for example.

Conversion between uplink FDMA channels and downlink multiple channel per carrier/time division multiplex (MCPC/TDM) channels is achieved on-board each satellite 25 at the baseband level. As will be described in further detail below, prime rate channels transmitted by a broadcast station 23 are demultiplexed at the satellite 25 into indi-

vidual 16 kbps baseband signals. The individual channels are then routed to one or more of the downlink beams 31a, 31b and 31c, each of which is a single TDM stream per carrier signal. This baseband processing provides a high level of channel control in terms of uplink frequency allocation and channel routing between uplink FDMA and downlink TDM signals.

The end-to-end signal processing that occurs in the system 10 is described with reference to FIG. 2. The system components responsible for the end-to-end signal processing is described in further detail below with reference to FIGS. 3-11. As shown in FIG. 2, audio signals from an audio source, for example, at a broadcast station 23, are preferably coded using MPEG 2.5 Layer 3 coding (block 26). The digital information assembled by a broadcast service provider at a broadcast station 23 is preferably formatted in 16 kbps increments or PRIs where n is the number of PRIs purchased by the service provider (i.e., n×16 kbps). The digital information is then formatted into a broadcast channel frame having a service control header (SCH) (block 28), described in further detail below. A periodic frame in the system 10 preferably has a period duration of 432 milliseconds (ms). Each frame is preferably assigned n×224 bits for the SCH such that the bit rate becomes approximately n×16.519 kbps. Each frame is next scrambled by addition of a pseudo random bit stream to the SCH. Information control of the scrambling pattern by a key permits encryption. The bits in a frame are subsequently coded for forward error correction (FEC) protection using preferably two concatenated coding methods such as the Reed Solomon method, followed by interleaving, and then convolution coding (e.g., trellis convolution coding described by Viterbi) (block 30). The coded bits in each frame corresponding to each PRI are subsequently subdivided or demultiplexed into n parallel prime rate channels (PRCs) (block 32). To implement recovery of each PRC, a PRC synchronization header is provided. Each of the n PRCs is next differentially encoded and then modulated using, for example, quadrature phase shift keying modulation onto an intermediate frequency (IF) carrier frequency (block 34). The n PRC IF carrier frequencies constituting the broadcast channel of a broadcast station 23 is converted to the X-band for transmission to the satellite 25, as indicated by the arrow 36.

The carriers from the broadcast stations 23 are single channel per carrier/frequency division multiple access (SCPC/FDMA) carriers. On-board each satellite 25, the SCPC/FDMA carriers are received, demultiplexed and demodulated to recover the PRC carriers (block 38). The PRC digital baseband channels recovered by the satellite 25 are subjected to a rate alignment function to compensate for clock rate differences between the on-board satellite clock and that of the PRC carriers received at the satellite (block 40). The demultiplexed and demodulated digital streams obtained from the PRCs are provided to TDM frame assemblers using routing and switching components. The PRC digital streams are routed from demultiplexing and demodulating equipment on-board the satellite 25 to the TDMA frame assemblers in accordance with a switching sequence unit on-board the satellite that is controlled from an earth station via a command link (e.g., a satellite control center 236 in FIG. 12 for each operating region). Three TDM carriers are created which correspond to each of the three satellite beams 31a, 31b and 31c (block 42). The three TDM carriers are up converted to L-band frequencies following QPSK modulation, as indicated by arrow 44. Radio receivers 29 are configured to receive any of the three TDM carriers and to demodulate the received carrier (block 46).

The radio receivers **29** are designed to synchronize a TDM bit stream using a master frame preamble provided during on-board satellite processing (block **48**). PRCs are demultiplexed from the TDM frame using a Time Slot Control Channel (TSCC), as well. The digital streams are then remultiplexed into the FEC-coded PRC format described above with reference to block **30** (block **50**). The FEC processing preferably includes decoding using a Viterbi trellis decoder, for example, deinterleaving, and then Reed Solomon decoding to recover the original broadcast channel comprising  $n \times 16$  kbps channel and the SCH. The  $n \times 16$  kbps segment of the broadcast channel is supplied to an MPEG 2.5 Layer 3 source decoder for conversion back to audio. In accordance with the present invention, the audio output is available via a very low cost broadcast radio receiver **27** due to the processing and TDM formatting described above in connection with the broadcast station(s) **23** and the satellite **25** (block **52**).

#### Unlink Multiplexing and Modulation

Signal processing to convert data streams from one or more broadcast stations **23** into parallel streams for transmission to a satellite **25** will now be described with reference to FIG. **3**. For illustrative purposes, four sources **60**, **64**, **68**, and **72** of program information are shown. Two sources **60** and **64**, or **68** and **72**, are coded and transmitted together as part of a single program or service. The coding of the program comprising combined audio sources **60** and **64** will be described. The signal processing of the program comprising digital information from sources **68** and **72** is identical.

As stated previously, broadcast stations **23** assemble information from one or more sources **60** and **64** for a particular program into broadcast channels characterized by increments of 16 kbps. These increments are referred to as prime rate increments or PRIs. Thus, the bit rate carried in a broadcast channel is  $n \times 16$  kbps where  $n$  is the number of PRIs used by that particular broadcast service provider. In addition, each 16 kbps PRI can be further divided into two 8 kbps segments which are routed or switched together through the system **10**. The segments provide a mechanism for carrying two different service items in the same PRI such as a data stream with low bit rate speech signals, or two low bit rate speech channels for two respective languages, and so on. The number of PRIs are preferably predetermined, that is, set in accordance with program code. The number  $n$ , however, is not a physical limitation of the system **10**. The value of  $n$  is generally set on the basis of business concerns such as the cost of a single broadcast channel and the willingness of the service providers to pay. In FIG. **3**,  $n$  for the first broadcast channel **59** for sources **60** and **64** is equal to 4. The value of  $n$  for the broadcast channel **67** for sources **68** and **72** is set to 6 in the illustrated embodiment.

As shown in FIG. **3**, more than one broadcast service provider can have access to a single broadcast station **23**. For example, a first service provider generates broadcast channel **59**, while a second service provider can generate broadcast channel **67**. The signal processing described herein and in accordance with the present invention allows data streams from several broadcast service providers to be broadcast to a satellite in parallel streams which reduces the cost of broadcasting for the service providers and maximizes use of the space segment. By maximizing efficiency of space segment usage, the broadcast stations **23** can be implemented less expensively using less power-consuming components. For example, the antenna at the broadcast station **23** can be very small aperture terminal (VSAT) antenna. The payload on the satellite requires less memory, less process-

ing capability and therefore fewer power sources which reduces payload weight.

A broadcast channel **59** or **67** is characterized by a frame **100** having a period duration of 432 ms, as shown in FIG. **4**. This period duration is selected to facilitate use of the MPEG source coder described below; however, the frame period in the system **10** can be set to a different predetermined value. If the period duration is 432 ms, then each 16 kbps PRI requires  $16,000 \times 0.432$  seconds = 6912 bits per frame. As shown in FIG. **4**, a broadcast channel therefore consists of a value  $n$  of these 16 kbps PRIs which are carried as a group in the frame **100**. As will be described below, these bits are scrambled to enhance demodulation at the radio receivers **29**. The scrambling operation also provides a mechanism for encrypting the service at the option of the service provider. Each frame **100** is assigned  $n \times 224$  bits which correspond to a service control header (SCH), resulting in a total of  $n \times 7136$  bits per frame and a bit rate of  $n \times (16,518 + 14 \times 27)$  bits per second. The purpose of the SCH is to send data to each of the radio receivers **29** tuned to receive the broadcast channel **59** or **67** in order to control reception modes for various multimedia services, to display data and images, to send key information for decryption, to address a specific receiver, among other features.

With continued reference to FIG. **3**, the sources **60** and **64** are coded using, for example, MPEG 2.5 Layer 3 coders **62** and **66**, respectively. The two sources are subsequently added via a combiner **76** and then processed using a processor at the broadcast station **23** to provide the coded signals in periodic frames of 432 ms, that is,  $n \times 7136$  bits per frame including the SCH, as indicated by processing module **78** in FIG. **3**. The blocks indicated at the broadcast station in FIG. **3** correspond to programmed modules performed by a processor and associated hardware such as digital memory and coder circuits. The bits in the frame **100** are subsequently coded for FEC protection using digital signal processing (DSP) software, application specific integrated circuits (ASICs) and custom large-scale integration (LSI) chips for the two concatenated coding methods. First, a Reed Solomon coder **80a** is provided to produce 255 bits for every 223 bits entering the coder. The bits in the frame **100** are then reordered according to a known interleaving scheme, as indicated by reference number **80b**. The interleaving coding provides further protection against bursts of error encountered in a transmission since this method spreads damaged bits over several channels. With continued reference to processing module **80**, a known convolution coding scheme of constraint length 7 is applied using a Viterbi coder **80c**. The Viterbi coder **83c** produces two output bits for every input bit, producing as a net result 16320 FEC-coded bits per frame for each increment of 6912 bits per frame applied in the broadcast channel **59**. Thus, each FEC-coded broadcast channel (e.g., channel **59** or **67**) comprises  $n \times 16320$  bits of information which have been coded, reordered and coded again such that the original broadcast 16 kbps PRIs are no longer identifiable. The FEC-coded bits, however, are organized in terms of the original 432 ms frame structure. The overall coding rate for error protection is  $(255/223) \times 2 = 2 + 64/223$ .

With continued reference to FIG. **3**, the  $n \times 16320$  bits of the FEC-coded broadcast channel frame is subsequently subdivided or demultiplexed using a channel distributor **82** into  $n$  parallel prime rate channels (PRCs), each carrying 16320 bits in terms of sets of 8160 two-bit symbols. This process is further illustrated in FIG. **4**. The broadcast channel **59** is shown which is characterized by a 432 ms frame **100** having an SCH **102**. The remaining portion **104** of the



frame consists of  $n$  16 kbps PRIs which corresponds to 6912 bits per frame for each of the  $n$  PRIs. The FEC-coded broadcast channel **106** is attained following concatenated Reed Solomon 255/223, interleaving and FEC 1/2 convolution coding described above in connection with module **80**. As stated previously, the FEC-coded broadcast channel frame **106** comprises  $n \times 16320$  bits which correspond to 8160 sets of two-bit symbols, with each symbol being designated by a reference numeral **108** for illustrated purposes. In accordance with the present invention, the symbols are assigned across the PRCs **110** in the manner shown in FIG. 4. Thus, the symbols will be spread on the basis of time and frequency which further reduces errors at the radio receiver caused by interference in transmission. The service provider for broadcast channel **59** has purchased four PRCs for illustrative purposes, whereas the service provider for broadcast channel **67** has purchased six PRCs for illustrative purposes. FIG. 4 illustrates the first broadcast channel **59** and the assignment of symbols **114** across the  $n=4$  PRCs **1101a**, **110b**, **110c** and **110d**, respectively. To implement recovery of each two-bit symbol **114** set at the receiver, a PRC synchronization header or preamble **112a**, **112b**, **112c** and **112d**, respectively, is placed in front of each PRC. The PRC synchronization header (hereinafter generally referred to using reference numeral **112**) contains 48 symbols. The PRC synchronization header **112** is placed in front of each group of 8160 symbols, thereby increasing the number of symbols per 432 ms frame to 8208 symbols. Accordingly, the symbol rate becomes  $8208/0.432$  which equals 19,000 kilosymbols per second (ksym/s) for each PRC **110**. The 48 symbol PRC preamble **112** is used essentially for synchronization of the radio receiver PRC clock to recover the symbols from the downlink satellite transmission **27**. At the on-board processor **116**, the PRC preamble is used to absorb timing differences between the symbol rates of arriving uplink signals and that used on-board to switch the signals and assemble the downlink TDM streams. This is done by adding, subtracting a "0" or neither to each 48 symbol PRC in the rate alignment process used on-board the satellite. Thus, the PRC preambles carried on the TDM downlink has 47, 48 or 49 symbols as determined by the rate alignment process. As shown in FIG. 4, symbols **114** are assigned to consecutive PRCs in a round-robin fashion such that symbol **1** is assigned to PRC **110a**, symbol **2** is assigned to PRC **110b**, symbol **3** is assigned to PRC **110c**, symbol **4** is assigned to PRC **110d**, symbol **5** is assigned to PRC **110e**, and so on. This PRC demultiplexing process is performed by a processor at the broadcast station **23** and is represented in FIG. 3 as the channel distribution (DEMUX) module **82**.

The PRC channel preambles are assigned to mark the beginning of the PRC frames **110a**, **110b**, **110c** and **110d** for broadcast channel **59** using the preamble module **84** and adder module **85**. The  $n$  PRCs are subsequently differentially encoded and then QPSK modulated onto an IF carrier frequency using a bank of QPSK modulators **86** as shown in FIG. 3. Four of the QPSK modulators **86a**, **86b**, **86c** and **86d** are used for respective PRCs **110a**, **110b**, **110c** and **110d** for broadcast channel **59**. Accordingly, there are four PRC IF carrier frequencies constituting the broadcast channel **59**. Each of the four carrier frequencies is up-converted to its assigned frequency location in the X-band using an up-converter **88** for transmission to the satellite **25**. The up-converted PRCs are subsequently transmitted through an amplifier **90** to the antenna (e.g., a VSAT) **92a** and **92b**.

In accordance with the present invention, the transmission method employed at a broadcast station **23** incorporates a multiplicity of  $n$  Single Channel Per Carrier, Frequency

Division Multiple Access (SCPC/FDMA) carriers into the uplink signal **21**. These SCPC/FDMA carriers are spaced on a grid of center frequencies which are preferably separated by 38,000 Hertz (Hz) from one another and are organized in groups of 48 contiguous center frequencies or carrier channels. Organization of these groups of 48 carrier channels is useful to prepare for demultiplexing and demodulation processing conducted on-board the satellite **25**. The various groups of 48 carrier channels are not necessarily contiguous to one another. The carriers associated with a particular broadcast channel (i.e., channel **59** or **67**) are not necessarily contiguous within a group of 48 carrier channels and need not be assigned in the same group of 48 carrier channels. The transmission method described in connection with FIGS. 3 and 4 therefore allows for flexibility in choosing frequency locations and optimizes the ability to fill the available frequency spectrum and to avoid interference with other users sharing the same radio frequency spectrum.

The system **10** is advantageous because it provides a common base of capacity incrementation for a multiplicity of broadcast companies or service providers whereby broadcast channels of various bit rates can be constructed with relative ease and transmitted to a receiver **29**. Typical broadcast channel increments or PRIs are preferably 16, 32, 48, 64, 80, 96, 112 and 128 kbps. The broadcast channels of various bit rates are interpreted with relative ease by the radio's receiver due to the processing described in connection with FIG. 4. The size and cost of a broadcast station can therefore be designed to fit the capacity requirements and financial resource limitations of a broadcast company. A broadcast company of meager financial means can install a small VSAT terminal requiring a relatively small amount of power to broadcast a 16 kbps service to its country that is sufficient to carry voice and music having quality far better than that of short-wave radio. On the other hand, a sophisticated broadcast company of substantial financial means can broadcast FM stereo quality with a slightly larger antenna and more power at 64 kbps and, with further increases in capacity, broadcast near compact disc (CD) stereo quality at 96 kbps and full CD stereo quality at 128 kbps.

The frame size, SCH size, preamble size and PRC length described in connection with FIG. 4 are used to realize a number of advantages; however, the broadcast station processing described in connection with FIGS. 3 and 4 is not limited to these values. The frame period of 432 ms is convenient when using an MPEG source coder (e.g., coder **62** or **66**). The 224 bits for each SCH **102** is selected to facilitate FEC coding. The 48 symbol PRC preamble **112** is selected to achieve 8208 symbols per PRC **110** to achieve 19,000 ksym/s for each PRC for a simplified implementation of multiplexing and demultiplexing on-board the satellite **25**, as described in future detail below. Defining symbols to comprise two-bits is convenient for QPSK modulation (i.e.,  $2^2=4$ ). To illustrate further, if phase shift key modulation at the broadcast station **23** uses eight phases as opposed to four phases, then a symbol defined as having three bits would be more convenient since each combination of three bits (i.e.,  $2^3$ ) can correspond to one of the eight phases.

Software can be provided at a broadcast station **23** or, if more than one broadcast station exists in the system **10**, a regional broadcast control facility (RBCF) **238** (FIG. 12) to assign space segment channel routing via a mission control center (MCC) **240**, a satellite control center (SCC) **236** and a broadcast control center (BCC) **244**. The software optimizes use of the uplink spectrum by assigning PRC carrier channels **110** wherever space is available in the 48 channel

groups. For example, a broadcast station may wish to broadcast a 64 kbps service on four PRC carriers. Due to current spectrum use, the four carriers may not be available in contiguous locations, but rather only in non-contiguous locations within a group of 48 carriers. Further, the RBCF **238** using its MCC and SCC may assign the PRCs to noncontiguous locations among different 48 channel groups. The MCC and SCC software at the RBCF **238** or a single broadcast station **23** can relocate PRC carriers of a particular broadcast service to other frequencies to avoid deliberate (i.e., jamming) or accidental interference on specific carrier locations. A current embodiment of the system has three RBCFs, one for each of the three regional satellites. Additional satellites can be controlled by one of these three facilities.

As will be described in further detail below in connection with on-board satellite processing in FIG. 6, an on-board digitally implemented polyphase processor is used for on-board signal regeneration and digital baseband recovery of the symbols **114** transmitted in the PRCs. The use of groups of 48 carriers spaced on center frequencies separated by 38,000 Hz facilitates processing by the polyphase processor. The software available at the broadcast station **23** or RBCF **238** can perform defragging, that is, defragmentation processing to optimize PRC **110** assignments to uplink carrier channels, that is, groups of 48 carrier channels. The principal behind defragmentation of uplink carrier frequency assignments is not unlike known software for reorganizing files on a computer hard drive which, over time, have been saved in such a piece-meal manner as to be inefficient for data storage. The BCC functions at the RBCF allows the RBCF to remotely monitor and control broadcast stations to assure their operation within assigned tolerances. Satellite Payload Processing

The baseband recovery on the satellite is important for accomplishing on-board switching and routing and assembly of TDM downlink carriers, each having 96 PRCs. The TDM carriers are amplified on-board the satellite **25** using single-carrier-per-traveling-wave-tube operation. The satellite **25** preferably comprises eight on-board baseband processors; however, only one processor **116** is shown. Preferably only six of the eight processors are used at a time, the remainder providing redundancy in event of failures and to command them to cease transmission if circumstances require such. A single processor **116** is described in connection with FIGS. 6 and 7. It is to be understood that identical components are preferably provided for each of the other seven processors **116**. With reference to FIG. 5, the coded PRC uplink carriers **21** are received at the satellite **25** by an X-band receiver **120**. The overall uplink capacity is preferably between 288 and 384 PRC uplink channels of 16 kbps each (i.e., 6×48 carriers if six processors **116** are used, or 8×48 carriers if all eight processors **116** are used). As will be described in further detail below, 96 PRCs are selected and multiplexed for transmission in each downlink beam **27** onto a carrier of approximately 2.5 MHz bandwidth.

Each uplink PRC channel can be routed to all, some or none of the downlink beams **27**. The order and placement of PRCs in a downlink beam is programmable and selectable from a telemetry, range and control (TRC) facility **24** (FIG. 1). Each polyphase demultiplexer and demodulator **122** receives the individual FDMA uplink signals in groups of 48 contiguous channels and generates a single analog signal on which the data of the 48 FDMA signals is time multiplexed, and performs a high speed demodulation of the serial data as described in further detail below in connection with FIG. 6. Six of these polyphase demultiplexer and demodulators **122**

operate in parallel to process 288 FDMA signals. A routing switch and modulator **124** selectively directs individual channels of the six serial data streams into all, some or none of the downlink signals **27** and further modulates and up-converts the three downlink TDM signals **27**. Three traveling wave tube amplifiers (TWTA) **126** individually amplify the three downlink signals, which are radiated to the earth by L-band transmit antennas **128**.

The satellite **25** also contains three transparent payloads, each comprising a demultiplexer and down-converter **130** and an amplifier group **132** configured in a conventional "bent pipe" signal path which converts the frequency of input signals for retransmission. Thus, each satellite **25** in the system **10** is preferably equipped with two types of communication payloads. The first type of on-board processing payload is described with reference to FIGS. 5, 6 and 7. The second type of communication payload is the transparent payload which converts uplink TDM carriers from frequency locations in the uplink X-band spectrum to frequency locations in the L-band downlink spectrum. The transmitted TDM stream for the transparent payload is assembled at a broadcast station **23**, sent to the satellite **25**, received and frequency converted to a downlink frequency location using module **130**, amplified by a TWTA in module **132** and transmitted to one of the beams. To a radio receiver **29**, the TDM signals appear identical whether they are from the on-board processing payload indicated at **121** or the transparent payload indicated at **133**. The carrier frequency locations of each type of payload **121** and **133** are spaced on separate grids of 920 kHz spacing which are interlaced between one another in a bisected manner so that the carrier locations of a mix of signals from both types of payloads **121** and **133** are on 460 kHz spacings.

The on-board demultiplexer and demodulator **122** will now be described in further detail with reference to FIG. 6. As shown in FIG. 6, SCPC/FDMA carriers, each of which is designated with reference numeral **136**, are assigned to groups of 48 channels. One group **138** is shown in FIG. 6 for illustrative purposes. The carriers **136** are spaced on a grid of center frequencies separated by 38 kHz. This spacing determines design parameters of the polyphase demultiplexers. For each satellite **25**, preferably 288 uplink PRC SCPC/FDMA carriers can be received from a number of broadcast stations **23**. Six polyphase demultiplexers and demodulators **122** are therefore preferably used. An on-board processor **116** accepts these PRC SCPC/FDMA uplink carriers **136** and converts them into three downlink TDM carriers, each carrying 96 of the PRCs in 96 time slots.

The 288 carriers are received by an uplink global beam antenna **118** and each group of 48 channels is frequency converted to an intermediate frequency (IF) which is then filtered to select a frequency band occupied by that particular group **138**. This processing takes places in the receiver **120**. The filtered signal is then supplied to an analog-to-digital (A/D) converter **140** before being supplied as an input to a polyphase demultiplexer **144**. The demultiplexer **144** separates the 48 SCPC/FDMA channels **138** into a time division multiplexed analog signal stream comprising QPSK modulated symbols that sequentially present the content of each of 48 SCPC/FDMA channels at the output of the demultiplexer **144**. This TDM analog signal stream is routed to a digitally implemented QPSK demodulator and differential decoder **146**. The QPSK demodulator and differential decoder **146** sequentially demodulates the QPSK modulated symbols into digital baseband bits. Demodulation processing requires symbol timing and carrier recovery. Since the modulation is QPSK, baseband symbols containing two-bits

each are recovered for each carrier symbol. The demultiplexer **144** and demodulator and decoder **146** will hereinafter be referred to as a demultiplexer/demodulator (D/D) **148**. The D/D is preferably accomplished using high speed digital technology using the known Polyphase technique to demultiplex the uplink carriers **21**. The QPSK demodulator is preferably a serially-shared, digitally-implemented demodulator for recovering the baseband two-bit symbols. The recovered symbols **114** from each PRC carrier **110** are subsequently differentially decoded to recover the original PRC symbols **108** applied at the input encoders, that is, the channel distributors **82** and **98** in FIG. **3**, at the broadcast station **23**. The satellite **25** payload preferably comprises six digitally implemented, 48 carrier D/Ds **148**. In addition, two spare D/Ds **148** are provided in the satellite payload to replace any failed processing units.

With continued reference to FIG. **6**, the processor **116** is programmed in accordance with a software module indicated at **150** to perform a synchronization and rate alignment function on the time division multiplexed symbol stream generated at the output of the QPSK demodulator and differential decoder **146**. The software and hardware components (e.g., digital memory buffers and oscillators) of the rate alignment module **150** in FIG. **6** are described in more detail with reference to FIG. **7**. The rate alignment module **150** compensates for clock rate differences between the on-board clock **152** and that of the symbols carried on the individual uplink PRC carriers **138** received at the satellite **25**. The clock rates differ because of different clock rates at different broadcast stations **23**, and different Doppler rates from different locations caused by motion of the satellite **25**. Clock rate differences attributed to the broadcast stations **23** can originate in clocks at a broadcast station itself or in remote clocks, the rates of which are transferred over terrestrial links between a broadcast studio and a broadcast station **23**.

The rate alignment module **150** adds or removes a "0" value symbol, or does neither operation in the PRC header portion **112** of each 432 ms recovered frame **100**. A "0" value symbol is a symbol that consists of a bit value 0 on both the I and Q channels of the QPSK-modulated symbol. The PRC header **112** comprises 48 symbols under normal operating conditions and consists of an initial symbol of "0" value, followed by 47 other symbols. When the symbol times of the uplink clock, which is recovered by the QPSK demodulator **146** along with the uplink carrier frequency, and those of the on-board clock **152** are synchronized, no change is made to the PRC preamble **112** for that particular PRC **110**. When the arriving uplink symbols have a timing that lags behind the on-board clock **152** by one symbol, a "0" symbol is added to the start of the PRC preamble **112** for the PRC currently being processed, yielding a length of 49 symbols. When the arriving uplink symbols have a timing that leads the on-board clock **152** by one symbol, a "0" symbol is deleted at the start of the PRC preamble **112** of the current PRC being processed, yielding a length of 47 symbols.

As stated previously, the input signal to the rate alignment module **150** comprises the stream of the recovered baseband two-bit symbols for each received uplink PRC at their individual original symbol rates. There are 288 such streams issued from the D/D **148** corresponding to each of the six active processors **116**. The action involving only one D/D **148** and one rate alignment module **150** is described, although it is to be understood that the other five active processors **116** on the satellite perform similar functions.

To rate align uplink PRC symbols to the on-board clock **152**, three steps are performed. First, the symbols are

grouped in terms of their original 8208 two-bit symbol PRC frames **110** in each buffer **149** and **151** of a ping-pong buffer **153**. This requires correlation of the PRC header **112** (which contains a 47 symbol unique word) with a local stored copy of the unique word in correlators indicated at **155** to locate the symbols in a buffer. Second, the number of on-board clock **152** ticks between correlation spikes is determined and used to adjust the length of the PRC header **112** to compensate for the rate difference. Third, the PRC frame, with its modified header, is clocked at the on-board rate into its appropriate location in a switching and routing memory device **156** (FIG. **8**).

PRC symbols enter the ping-pong buffer pair **153** at the left. The ping-pong action causes one buffer **149** or **151** to fill at the uplink clock rate, and the other buffer to simultaneously empty at the on-board clock rate. The roles reverse from one frame to the next and cause continuous flow between input and output of the buffer **149** and **151**. Newly arriving symbols are written to the buffer **149** or **151** to which they happen to be connected. Writing continues to fill the buffer **149** or **151** until the correlation spike occurs. Writing then stops, and the input and output switches **161** and **163** switch to the reverse state. This captures an uplink PRC frame so that its 48 header symbols reside in the 48 symbol slots with one slot left unfilled at the output end of the buffer and the 8160 data symbols fill the first 8160 slots. The contents of the subject buffer are immediately read to the output thereof at the on-board clock rate. The number of symbols read out are such that the PRC header contains 47, 48 or 49 symbols. A "0" value symbol is removed or added at the start of the PRC header to make this adjustment. The header length **112** is controlled by a signal coming from a frame symbol counter **159** which counts the number of on-board clock rate symbols that will fall in a PRC frame period to determine the header length. The ping-pong action alternates the roles of the buffers.

To perform the count, the frame correlation spikes coming from the buffer correlators **155**, as PRC frames fill the buffers **149** and **151**, are smoothed by a synch pulse oscillator (SPC) **157**. The smoothed sync pulses are used to count the number of symbol epochs per frame. The number will be 8207, 8208 or 8209 indicating whether the PRC header should be 47, 48 or 49 symbols long, respectively. This information causes the proper number of symbols to come from the frame buffers to maintain symbol flow synchronously with the on-board clock and independently of earth terminal origin.

For the rate differences anticipated over the system **10**, the run times between preamble **112** modifications are relatively long. For instance, clock rate differences of  $10^{-6}$  will elicit PRC preamble corrections on the average of one every 123 PRC frames. The resulting rate adjustments cause the symbol rates of the PRCs **110** to be precisely synchronized to the on-board clock **152**. This allows routing of the baseband bit symbols to the proper locations in a TDM frame. The synchronized PRCs are indicated generally at **154** in FIG. **6**. The on-board routing and switching of these PRCs **154** into TDM frames will now be described with reference to FIG. **8**.

FIG. **6** illustrates PRC processing by a single D/D **148**. Similar processing is performed by the other five active D/Ds on-board the satellite. The PRCs emanating from each of the six D/Ds **148**, having been synchronized and aligned, occur in a serial stream having a symbol rate of  $48 \times 19,000$  which equals 912,000 symbols per second for each D/D **148**. The serial stream from each D/D **148** can be demultiplexed into 48 parallel PRC streams having rates of 19,000 symbols

per second, as shown in FIG. 7. The aggregate of the PRC streams coming from all six D/Ds **148** on-board the satellite **25** is 288, with each D/D **148** carrying 19,000 sym/s streams. The symbols therefore have epochs or periods of 1/19,000 seconds which equals approximately 52.63 microseconds

As shown in FIG. 8, 288 symbols are present at the outputs of the six D/Ds **148a**, **148b**, **148c**, **148d**, **148e** and **148f** for every uplink PRC symbol epoch. Once each PRC symbol epoch, 288 symbol values are written into a switching and routing memory **156**. The contents of the buffer **156** are read into three downlink TDM frame assemblers **160**, **162** and **164**. Using a routing and switching component designated as **172**, the contents of each of the 288 memory locations are read in terms of 2622 sets of 96 symbols to each of the three TDM frames in assemblers **160**, **162** and **164** in an epoch of 136.8 ms which occurs once every TDM frame period or 138 ms. The scan rate or 136.8/2622 is therefore faster than the duration of a symbol. The routing switch and modulator **124** comprises a ping-pong memory configuration indicated generally at **156** and comprising buffers **156a** and **156b**, respectively. The 288 uplink PRCs indicated at **154** are supplied as input to the routing switch and modulator **124**. The symbols of each PRC occur at a rate of 19,000 symbols per second corrected to the on-board clock **152** timing. The PRC symbols are written in parallel at the 19,000 Hz clock rate into 288 positions in the ping-pong memory **156a** or **156b** serving as the input. At the same time, the memory serving as the output **156b** or **156a**, respectively, is reading the symbols stored in the previous frame into the three TDM frames at a read rate of 3×1.84 Mhz. This latter rate is sufficient to allow the simultaneous generation of the three TDM parallel streams, one directed to each of three beams. Routing of the symbols to their assigned beam is controlled by a symbol routing switch **172**. This switch can route a symbol to any one, two or three of the TDM streams. Each TDM stream occurs at a rate of 1.84 Msym/s. The output memory is clocked for an interval of 136.8 ms and pauses for 1.2 ms to allow insertion of the 96 symbol MFP and 2112 symbol TSCC. Note that for every symbol that is read into more than one TDM stream, there is an off-setting uplink FDM PRC channel that is not used and is skipped. The ping-pong memory buffers **156a** and **156b** exchange roles from frame to frame via the switch components **158a** and **158b**.

With continued reference to FIG. 8, sets of 96 symbols are transferred to 2622 corresponding slots in each TDM frame. The corresponding symbols (i.e., the *i*th symbols) for all 96 uplink PRCs are grouped together in the same TDM frame slot as illustrated by the slot **166** for symbol **1**. The contents of the 2622 slots of each TDM frame are scrambled by adding a pseudorandom bit pattern to the entire 136.8 ms epoch. In addition, a 1.2 ms epoch is appended at the start of each TDM frame to insert a master frame preamble (MFP) of 96 symbols and a TSCC of 2112 symbols, as indicated at **168** and **170**, respectively. The sum of the 2622 time slots, each carrying 96 symbols, and the symbols for the MFP and TSCC is 253,920 symbols per TDM frame, resulting in a downlink symbol rate of 1.84 Msym/s.

The routing of the PRC symbols between the outputs of the six D/Ds **148A**, **148B**, **148C**, **148D**, **148E** and **148F** and the inputs to the TDM frame assemblers **160**, **162** and **164** is controlled by an on-board switching sequence unit **172** which stores instructions sent to it over a command link from the SCC **238** (FIG. 12) from the ground. Each symbol originating from a selected uplink PRC symbol stream can be routed to a time slot in a TDM frame to be transmitted to

a desired destination beam **27**. The method of routing is independent of the relationships between the time of occurrence of symbols in various uplink PRCs and the occurrence of symbols in the downlink TDM streams. This reduces the complexity of the satellite **25** payload. Further, a symbol originating from a selected uplink PRC can be routed to two or three destination beams via the switch **158**.

#### Radio Receiver Operation

A radio receiver **29** for use in the system **10** will now be described with reference to FIG. 9. The radio receiver **29** comprises an radio frequency (RF) section **176** having an antenna **178** for L-band electromagnetic wave reception, and prefiltering to select the operating band of the receiver (e.g., 1452 to 1492 MHz). The RF section **176** further comprises a low noise amplifier **180** which is capable of amplifying the receive signal with minimum self-introduced noise and of withstanding interference signals that may come from another service sharing the operating band of the receiver **29**. A mixer **182** is provided to down-convert the received spectrum to an intermediate frequency (IF). A high performance IF filter **184** selects the desired TDM carrier bandwidth from the output of the mixer **182** and a local oscillator synthesizer **186**, which generates the mixing input frequencies needed to down-convert the desired signal to the center of the IF filter. The TDM carriers are located on center frequencies spaced on a grid having 460 kHz separations. The bandwidth of the IF filter **184** is approximately 2.5 MHz. The separation between carriers is preferably at least seven or eight spaces or approximately 3.3 MHz. The RF section **176** is designed to select the desired TDM carrier bandwidth with a minimum of internally-generated interference and distortion and to reject unwanted carriers that can occur in the operating band from 152 to 192 MHz. In most areas of the world, the levels of unwanted signals are nominal, and typically the ratios of unwanted signals to desired signals of 30 to 40 dB provides sufficient protection. In some areas, operations near high power transmitters (e.g., in the vicinity of terrestrial microwave transmitters for public switched telephone networks or other broadcast audio services) requires a front end design capable of better protection ratios. The desired TDM carrier bandwidth retrieved from the downlink signal using the RF section **176** is provided to an A/D converter **188** and then to a QPSK demodulator **190**. The QPSK demodulator **190** is designed to recover the TDM bit stream transmitted from satellite **25**, that is, via the on-board processor payload **121** or the on-board transparent payload **133**, on a selected carrier frequency.

The QPSK demodulator **190** is preferably implemented by first converting the IF signal from the RF section **176** into a digital representation using the A/D converter **188**, and then implementing the QPSK using a known digital processing method. Demodulation preferably uses symbol timing and carrier frequency recover and decision circuits which sample and decode the symbols of the QPSK modulated signal into the baseband TDM bit stream.

The A/D converter **188** and QPSK demodulator **190** are preferably provided on a channel recovery chip **187** for recovering the broadcast channel digital baseband signal from the IF signals recovered by the RF/IF circuit board **176**. The channel recovery circuit **187** comprises a TDM synchronizer and predictor module **192**, a TDM demultiplexer **194**, a PRC synchronizer alignment and multiplexer **196**, the operations of which will be described in further detail in connection with FIG. 10. The TDM bit stream at the output of the QPSK demodulator **190** is provided to a MFP synchronization correlator **200** in the TDM synchronizer and

predictor module **192**. The correlator **200** compares the bits of the received stream to a stored pattern. When no signal has previously been present at the receiver, the correlator **200** first enters a search mode in which it searches for the desired MFP correlation pattern without any time gating or aperture limitation applied to its output. When the correlator discovers a correlation event, it enters a mode wherein a gate opens at a time interval in which a next correlation event is anticipated. If a correlation event occurs again within the predicted time gate epoch, the time gating process is repeated. If correlation occurs for five consecutive time frames, for example, synchronization is declared to have been determined in accordance with the software. The synchronization threshold, however, can be changed. If correlation has not occurred for the minimum number of consecutive time frames to reach the synchronization threshold, the correlator continues to search for the correlation pattern.

Assuming that synchronization has occurred, the correlator enters a synchronization mode in which it adjusts its parameters to maximize probability of continued synchronization lock. If correlation is lost, the correlator enters a special predictor mode in which it continues to retain synchronization by prediction of the arrival of the next correlation event. For short signal dropouts (e.g., for as many as ten seconds), the correlator can maintain sufficiently accurate synchronization to achieve virtually instantaneous recovery when the signal returns. Such rapid recovery is advantageous because it is important for mobile reception conditions. If, after a specified period, correlation is not reestablished, the correlator **200** returns to the search mode. Upon synchronization to the MFP of the TDM frame, the TSCC can be recovered by the TDM demultiplexer **194** (block **202** in FIG. **10**). The TSCC contains information identifying the program providers carried in the TDM frame and in which locations of the 96 PRCs each program provider's channel can be found. Before any PRCs can be demultiplexed from the TDM frame, the portion of the TDM frame carrying the PRC symbols is preferably descrambled. This is done by adding the same scrambling pattern at the receiver **29** that was added to the PRC portion of the TDM frame bit stream on-board the satellite **25**. This scrambling pattern is synchronized by the TDM frame MFP.

The symbols of the PRCs are not grouped contiguously in the TDM frame, but are spread over the frame. There are 2622 sets of symbols contained in the PRC portion of the TDM frame. In each set, there is one symbol for each PRC in a position which is numbered in ascending order from 1 to 96. Thus, all symbols belonging to PRC **1** are in the first position of all 2622 sets. Symbols belonging to PRC **2** are in the second position of all 2622 sets, and so on, as shown in block **204**. This arrangement for numbering and locating the symbols of the PRCs in the TDM frame, in accordance with the present invention, minimizes the size of the memory for performing the switching and routing on-board the satellite and for demultiplexing in the receiver. As shown in FIG. **9**, the TSCC is recovered from the TDM demultiplexer **194** and provided to the controller **220** at the receiver **29** to recover the *n* PRCs for a particular broadcast channel. The symbols of the *n* PRCs associated with that broadcast channel are extracted from the unscrambled TDM frame time slot locations identified in the TSCC. This association is performed by a controller contained in the radio and is indicated generally. The controller **220** accepts a broadcast selection identified by the radio operator, combines this selection with the PRC information contained in the TSCC, and extracts and reorders the symbols of the PRCs from the TDM frame to restore the *n* PRCs.

With reference to blocks **196** and **206**, respective, in FIGS. **9** and **10**, the symbols of each of the *n* PRCs associated with a broadcast channel selected by the radio operator are remultiplexed into an FEC-coded broadcast channel (BC) format. Before the remultiplexing is accomplished, the *n* PRCs of a broadcast channel are realigned. Realignment is useful because reclocking of symbol timing encountered in multiplexing, demultiplexing and on-board rate alignment in passage over the end-to-end link in system **10** can introduce a shift of as many as four symbols in the relative alignment of the recovered PRC frames. Each of the *n* PRCs of a broadcast channel has a 48 symbol preamble, followed by 8160 coded PRC symbols. To recombine these *n* PRCs into the broadcast channel, synchronization is performed to the 47, 48 or 49 symbol header of each of the PRCs. The length of the header depends on the timing alignment performed on the uplink PRCs on the satellite **25**. Synchronization is accomplished using a preamble correlator operating on the 47 most recently received symbols of the PRC header for each of the *n* PRCs. The preamble correlator detects incidents of correlation and emits a single symbol duration correlation spike. Based on the relative time of occurrence of the correlation spikes for the *n* PRCs associated with the broadcast channel, and operating in conjunction with alignment buffers having a width of four symbols, the symbol content of the *n* PRCs can be precisely aligned and remultiplexed to recover the FEC-coded broadcast channel. Remultiplexing of the *n* PRCs to reform the FEC-coded broadcast channel preferably requires that the symbol spreading procedure used at the broadcast station **23** for demultiplexing the FEC-coded broadcast channel into the PRCs be performed in the reverse order, as indicated in block **208** of FIG. **10**.

FIG. **11** illustrates how a broadcast channel, comprising four PRCs, for example, is recovered at the receiver. At the left, four demodulated PRCs are shown arriving. Due to reclocking variations, and different time delays encountered from the broadcast station through the satellite to the radio, up to four symbols of relative offset can occur among the *n* PRCs constituting a broadcast channel. The first step in recovery is to realign the symbol content of these PRCs. This is done by a set of FIFO buffers each having a length equal to the range of variation. Each PRC has its own buffer **222**. Each PRC is first supplied to a PRC header correlator **226** that determines the instant of arrival. The arrival instants are shown by a correlation spike **224** for each of the four PRCs in the illustration. Writing (W) starts into each buffer **222** immediately following the instant of correlation and continues thereafter until the end of the frame. To align the symbols to the PRCs, reading (R) from all of the buffers **222** starts at the instant of the last correlation event. This causes the symbols of all PRCs to be synchronously read out in parallel at the buffer **222** outputs. The realigned symbols **228** are next multiplexed via a multiplexer **230** into a single serial stream that is the recovered coded broadcast channel **232**. Due to on-board clock **152** rate alignment, the length of the PRC header may be 47, 48 or 49 symbols long. This variation is eliminated in the correlator **226** by using only the last 47 symbols to arrive to detect the correlation event. These 47 symbols are specially selected to yield optimum correlation detection.

With reference to block **198** and **210** of FIGS. **9** and **10** respectively, the FEC-coded broadcast channel is subsequently provided to the FEC processing module **210**. Most of the errors encountered in transmission between the location of the coders and the decoders is corrected by FEC processing. FEC processing preferably employs a Viterbi

Trellis Decoder, followed by deinterleaving and then a Reed Solomon decoder. FEC processing recovers the original broadcast channel comprising  $n \times 16$  kbps channel increments and its  $n \times 224$  bit SCH (block 212).

The  $n \times 16$  kbps segment of the broadcast channel is provided to a decoder such as MPEG 2.5 Layer 3 source decoder 214 for conversion back to audio signals. Thus, receiver processing is available using a low cost radio for broadcast channel reception from satellites. Since the transmissions of the broadcast programs via satellites 25 is digital, a number of other services are supported by the system 10 which are also expressed in digital format. As stated previously, the SCH contained in the broadcast channels provides a control channel for a wide variety of future service options. Thus, chip sets can be produced to implement these service options by making the entire TDM bit stream and its raw demodulated format, the demultiplexed TSCC information bits, and the recovered error corrected broadcast channel available. Radio receivers 29 can also be provided with an identification code for uniquely addressing each radio. The code can be accessed by means of bits carried in a channel of the SCH of the broadcast channel. For mobile operation using the radio receiver 29 in accordance with the present invention, the radio is configured to predict and recover substantially instantaneously the locations of MFP correlation spikes to an accuracy of  $\frac{1}{4}$ th symbol for intervals of as many as ten seconds. A symbol timing local oscillator having a short time accuracy of better than one part per 100,000,000 is preferably installed in the radio receiver, particularly for a hand-held radio 29b.

#### System for Managing Satellite and Broadcast Stations

As stated previously, the system 10 can comprise one or a plurality of satellites 25. FIG. 12 depicts three satellites 25a, 25b and 25c for illustrative purposes. A system 10 having several satellites preferably comprises a plurality of TCR stations 24a, 24b, 24c, 24d and 24e located such that each satellite 25a, 25b and 25c is in line of sight of two TCR stations. The TCR stations referred to generally with reference numeral 24 are controlled by a regional broadcast control facility (RBCF) 238a, 238b or 238c. Each RBCF 238a, 238b and 238c comprises a satellite control center (SCC) 236a, 236b and 236c, a mission control center (MCC) 240a, 240b and 240c, and a broadcast control center (BCC) 244a, 244b and 244c, respectively. Each SCC controls the satellite bus and the communications payload and is where a space segment command and control computer and manpower resources are located. The facility is preferably manned 24 hours a day by a number of technicians trained in in-orbit satellite command and control. The SCCs 236a, 236b and 236c monitor the on-board components and essentially operate the corresponding satellite 25a, 25b and 25c. Each TCR station 24 is preferably connected directly to a corresponding SCC 236a, 236b or 236c by full-time, dual redundant PSTN circuits.

In each of the regions serviced by the satellites 25a, 25b and 25c, the corresponding RBCF 238a, 238b and 238c reserves broadcast channels for audio, data, video image services, assigns space segment channel routing via the mission control center (MCC) 240a, 240b, 240c, validates the delivery of the service, which is information required to bill a broadcast service provider, and bills the service provider.

Each MCC is configured to program the assignment of the space segment channels comprising uplink PRC frequency and downlink PRC TDM slot assignments. Each MCC performs both dynamic and static control. Dynamic control involves controlling time windows for assignments, that is,

assigning space segment usage on a monthly, weekly and daily basis. Static control involves space segment assignments that do not vary on a monthly, weekly and daily basis. A sales office, which has personnel for selling space segment capacity at the corresponding RBCF, provides the MCC with data indicating available capacity and instructions to seize capacity that has been sold. The MCC generates an overall plan for occupying the time and frequency space of the system 10. The plan is then converted into instructions for the on-board routing switch 172 and is sent to the SCC for transmission to the satellite. The plan can be updated and transmitted to the satellite preferably once every 12 hours. The MCC 240a, 240b and 240c also monitors the satellite TDM signals received by corresponding channel system monitor equipment (CSME) 242a, 242b and 242c. CSME stations verify that broadcast stations 23 are delivering broadcast channels within specifications.

Each BCC 244a, 244b and 244c monitors the broadcast earth stations 23 in its region for proper operation within selected frequency, power and antenna pointing tolerances. The BCCs can also connect with corresponding broadcast stations to command malfunctioning stations off-the-air. A central facility 246 is preferably provided for technical support services and back-up operations for each of the SCCs.

While certain advantageous embodiments have been chosen to illustrate the invention, it will be understood by those skilled in the art that various changes and modifications can be made therein without departing from the scope of the invention as defined in the appended claims.

What is claimed is:

1. Apparatus for switching symbols in parallel broadcast channels transmitted as respective frequency division multiple access carriers to time division multiplexed data streams comprising:

first and second ping-pong buffers, said first ping-pong buffer being configured to store a first plurality of said symbols in said parallel broadcast channels therein, said second ping-pong buffer being operable to store a second plurality of said symbols in said parallel broadcast channels therein, said second plurality of said symbols in said parallel broadcast channels having arrived at said second ping-pong buffer prior to the arrival of said first plurality of said symbols in said parallel broadcast channels at said first ping-pong buffer;

a routing switch connected to the outputs of said first and second ping-pong buffers; and

a first frame assembler connected to said routing switch, said routing switch being operable to control the writing of the contents of said second ping-pong buffer to said first frame assembler.

2. An apparatus as claimed in claim 1, further comprising a second frame assembler connected to said routing switch, said routing switch being operable to control the writing of the contents of said second ping-pong buffer to at least one of said first frame assembler and said second frame assembler.

3. An apparatus as claimed in claim 2, wherein said routing switch is operable control the writing of the contents of said second ping-pong buffer to both of said first frame assembler and said second frame assembler to generate two parallel time division multiplexed data streams.

4. An apparatus as claimed in claim 2, wherein said second frame assembler stores at least one framing bit to identify said symbols stored therein as a frame.

5. An apparatus as claimed in claim 4, wherein said frame comprises time slots and said second frame assembler stores

at least one bit representing a time slot control channel to indicate in which of said time slots said symbols corresponding to respective ones of said parallel broadcast channels are stored.

6. An apparatus as claimed in claim 1, wherein said second ping-pong buffer is operable to store a third plurality of said broadcast channels, said routing switch being operable to control the writing of the contents of said first ping-pong buffer to said first frame assembler.

7. An apparatus as claimed in claim 1, wherein said first ping-pong buffer is operable to switch as few as a single one of said first plurality of said symbols therein at one time.

8. An apparatus as claimed in claim 1, wherein said second ping-pong buffer is operable to switch as few as a single one of said second plurality of said symbols therein at one time.

9. An apparatus as claimed in claim 1, wherein said first frame assembler is operable to insert at least one framing bit in said second ping-pong buffer to identify said symbols stored in said second ping-pong buffer as a frame.

10. An apparatus as claimed in claim 9, wherein said frame comprises time slots and said first frame assembler is operable to insert at least one bit representing a time slot control channel in said second ping-pong buffer to indicate in which of said time slots said symbols corresponding to respective ones of said parallel broadcast channels are stored.

11. An apparatus as claimed in claim 1, wherein said apparatus is on-board a satellite and said routing switch is controllable via control signals generated by a ground station and transmitted to said satellite.

12. A method of switching symbols in parallel broadcast channels to time division multiplexed data streams comprising the steps of:

receiving said parallel broadcast channels transmitted via frequency division multiple access carriers;

storing a symbol from each of said parallel broadcast channels into a routing buffer;

receiving a control signal designating to which of a plurality of frame assembler buffers said symbols in said routing buffer are to be written, said time division multiplexed data streams comprising frames, the duration of a frame corresponding to a symbol epoch; and

writing the contents of said routing buffer to at least one of said plurality of frame assembler buffers once symbol epoch in accordance with said control signal.

13. A method as claimed in claim 12, wherein said storing step comprises the step of:

storing a first plurality of symbols from respective ones of said parallel broadcast channels in a first memory location of said routing buffer;

storing a second plurality of symbols from respective ones of said parallel broadcast channels in a second memory location of said routing buffer, said second plurality of symbols having arrived at said second memory location prior to the arrival of said first plurality of symbols at said first memory location.

14. A method as claimed in claim 13, wherein said writing step comprises the step of writing said second plurality of symbols to at least one of said plurality of frame assembler buffers while said first plurality of symbols are being stored in said first memory location of said routing buffer.

\* \* \* \* \*