



US006320180B1

(12) **United States Patent**
Estrera et al.

(10) **Patent No.:** **US 6,320,180 B1**
(45) **Date of Patent:** **Nov. 20, 2001**

(54) **METHOD AND SYSTEM FOR ENHANCED VISION EMPLOYING AN IMPROVED IMAGE INTENSIFIER AND GATED POWER SUPPLY**

5,776,538 * 7/1998 Pierle et al. 427/78
5,949,063 * 9/1999 Saldana et al. 250/214 VT
6,072,565 * 6/2000 Porter 356/5.04
6,157,021 * 12/2000 Fish 250/214 VT

(75) Inventors: **Joseph P. Estrera**, Dallas; **John W. Glesener**, Richardson; **Michael R. Saldaña**, New Braunfels, all of TX (US)

* cited by examiner

(73) Assignee: **Litton Systems, Inc.**, Woodland Hills, CA (US)

Primary Examiner—Stephone B. Allen

(74) Attorney, Agent, or Firm—Baker Botts L.L.P.

(*) Notice: Subject to any disclaimer, the term of this patent is extended or adjusted under 35 U.S.C. 154(b) by 0 days.

(57) **ABSTRACT**

The present invention comprises a method for detecting photons and generating a representation of an image. A photocathode receives photons from an image. A power supply to the photocathode is gated such that the photocathode is switched between an on state and an off state. The photocathode discharges electrons in response to the received photons while the photocathode is in the on state. A microchannel plate with an unfilmed input face and an output face receives the electrons from the photocathode and produces secondary emission electrons which are emitted from the output face. A screen receives the secondary electrons and displays a representation of the image.

(21) Appl. No.: **09/325,359**

(22) Filed: **Jun. 4, 1999**

(51) Int. Cl.⁷ **H01J 31/50**

(52) U.S. Cl. **250/214 VT; 427/78; 313/103 CM**

(58) Field of Search 250/214 VT, 207; 313/103 CM, 105 CM, 103 R, 105 R, 359.1, 360.1; 356/5.04, 5.01; 427/78, 77

(56) **References Cited**

U.S. PATENT DOCUMENTS

4,044,429 * 8/1977 Moore et al. 250/214 VT

20 Claims, 3 Drawing Sheets

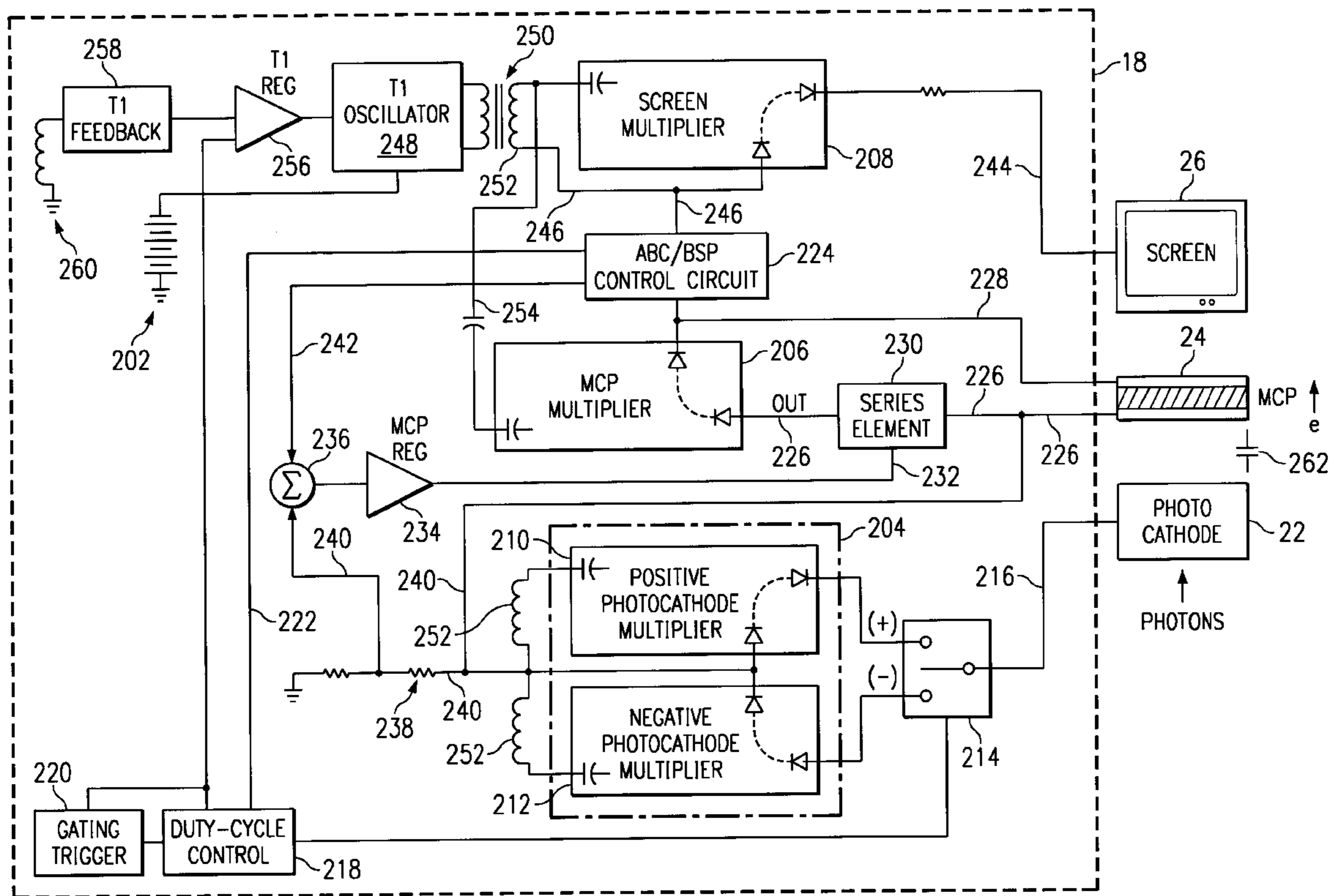

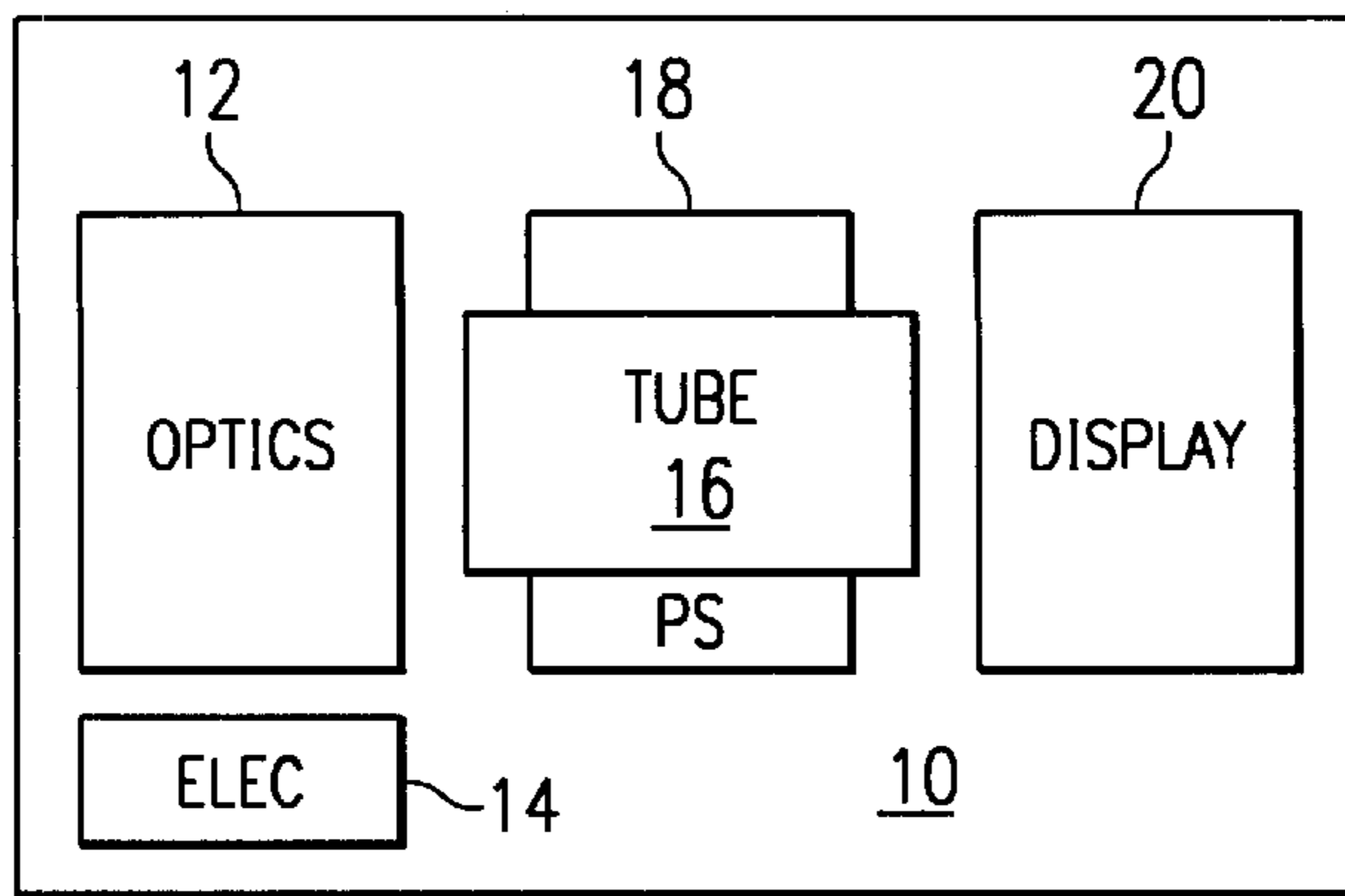

FIG. 1

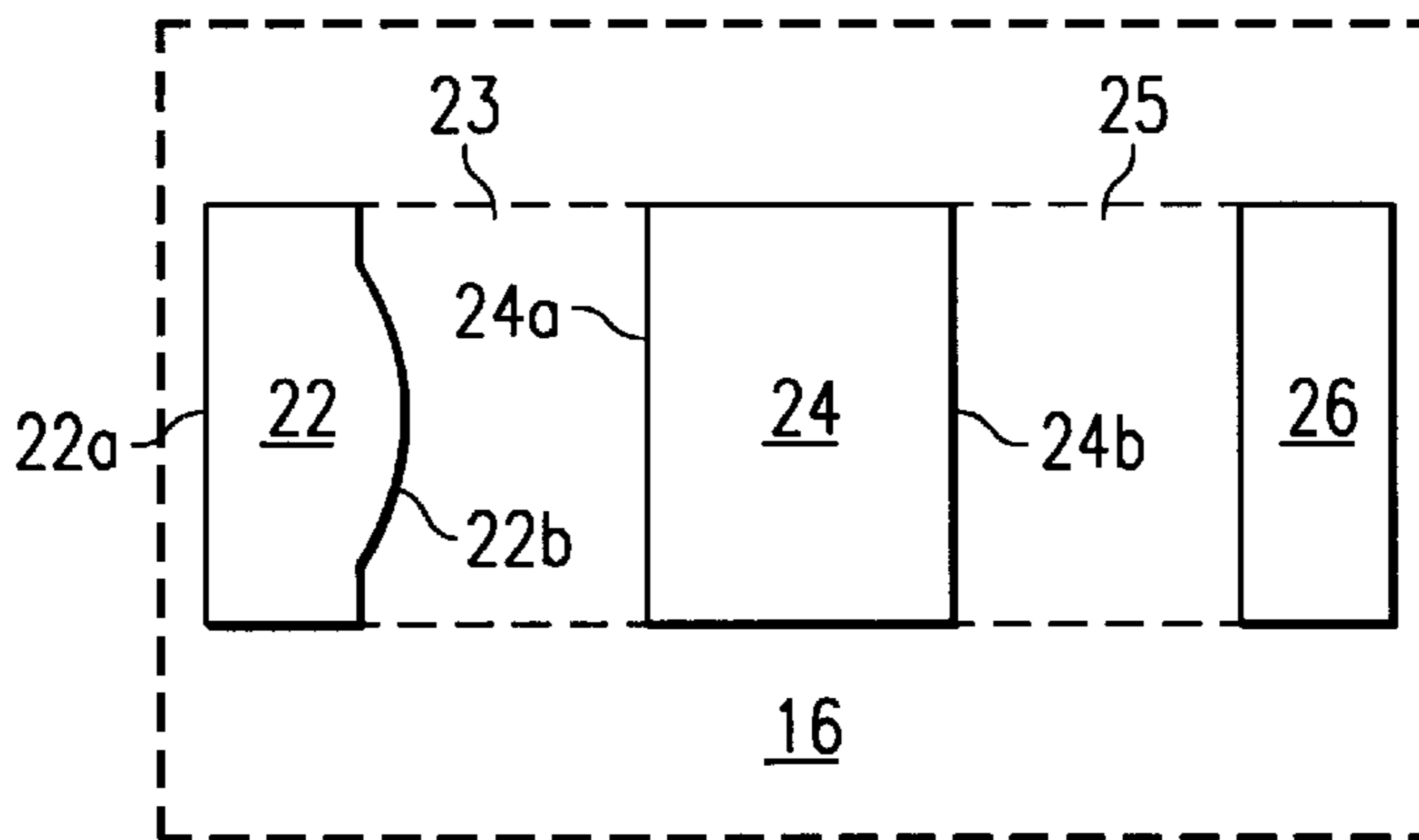

FIG. 2

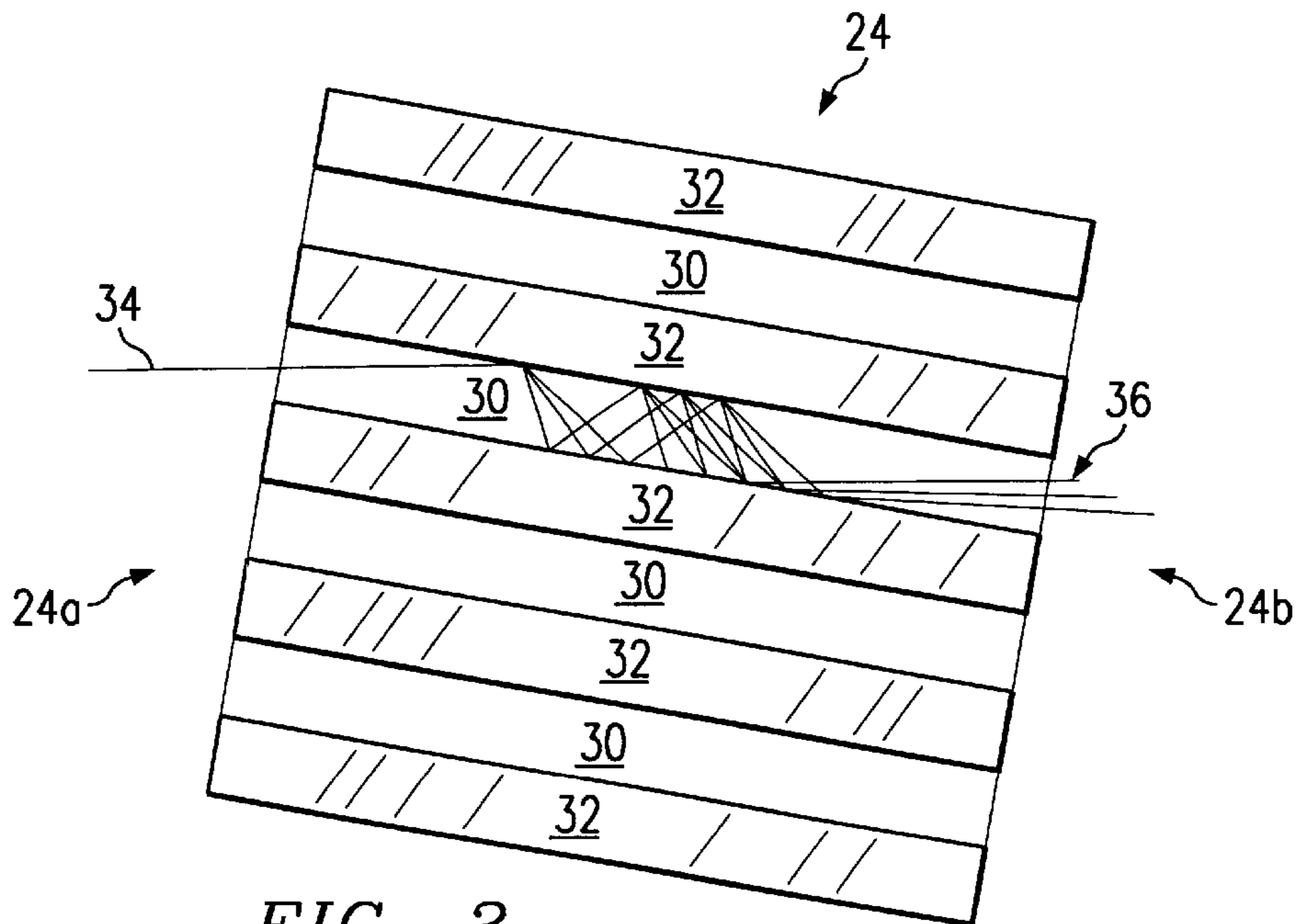

FIG. 3

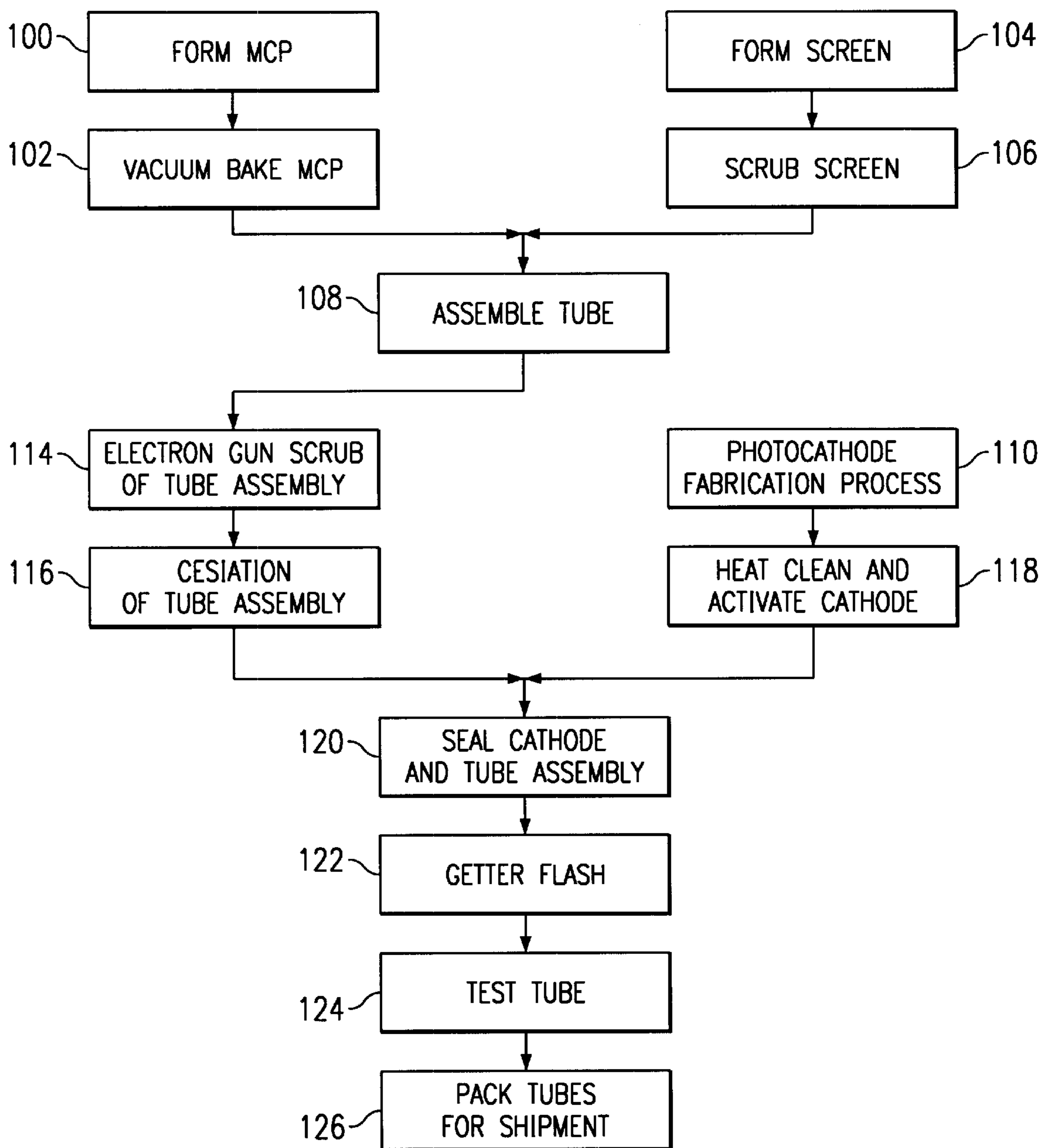

FIG. 4

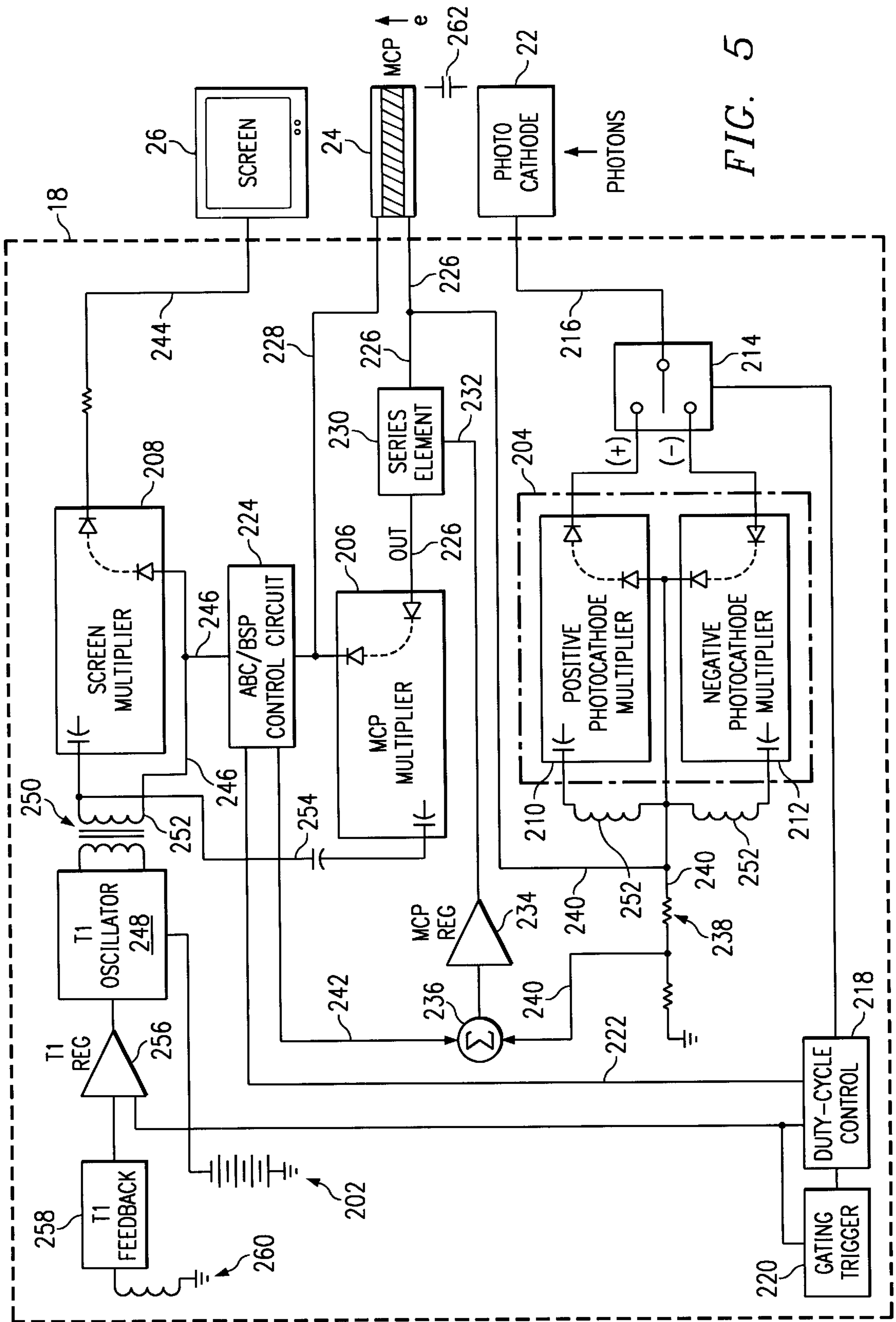

FIG. 5

**METHOD AND SYSTEM FOR ENHANCED
VISION EMPLOYING AN IMPROVED
IMAGE INTENSIFIER AND GATED POWER
SUPPLY**

RELATED APPLICATIONS

This application is related to copending U.S. application Ser. No. 09/326,253, entitled "METHOD AND SYSTEM FOR ENHANCED VISION EMPLOYING AN IMPROVED IMAGE INTENSIFIER" copending U.S. application Ser. No. 09/326,252, entitled "METHOD AND SYSTEM FOR ENHANCED VISION EMPLOYING AN IMPROVED IMAGE INTENSIFIER AND REDUCED HALO" and copending U.S. application Ser. No. 09/326,148, entitled "METHOD AND SYSTEM FOR ENHANCED VISION EMPLOYING AN IMPROVED IMAGE INTENSIFIER WITH GATED POWER SUPPLY AND REDUCED HALO" and copending U.S. application Ser. No. 09/326,054, entitled "METHOD AND SYSTEM FOR MANUFACTURING MICROCHANNEL PLATES".

TECHNICAL FIELD OF THE INVENTION

This invention relates generally to vision systems and more particularly to a method and system for enhanced vision employing an improved image intensifier and gated power supply.

BACKGROUND OF THE INVENTION

Image intensifier tubes are used in night vision devices to amplify light and allow a user to see images in very dark conditions. Night vision devices typically include a lens to focus light onto the light receiving end of an image intensifier tube and an eyepiece at the other end to view the enhanced imaged produced by the image intensifier tube.

Modern image intensifier tubes use photocathodes. Photocathodes emit electrons in response to photons impinging on the photocathodes. The electrons are produced in a pattern that replicates the original scene. The electrons from the photocathode are accelerated towards a microchannel plate. A microchannel plate is typically manufactured from lead glass and has a multitude of microchannels, each one operable to produce a cascade of secondary electrons in response to an incident electron.

Therefore, photons impinge on the photocathode producing electrons which are then accelerated to a microchannel plate where a cascade of secondary electrons are produced. These electrons impinge on a phosphorous screen, producing an image of the scene.

A drawback to this approach is that the electrostatic fields in the image intensifier are not only effective in accelerating electrons from the photocathode to the microchannel plate and from the microchannel plate to the screen, but also move any positive ions back to the photocathode at an accelerated velocity. Current image intensifiers have a high indigenous population of positive ions. These are primarily due to gas ions in the tube, including in the microchannel plate and the screen. These include both positive ions and chemically active neutral atoms. When these ions strike the photocathode, they can cause both physical and chemical damage. This leads to short operating lives for image intensifiers.

To overcome this problem, an ion barrier film can be placed on the input side of the microchannel plate. This ion barrier is able to block the ions from the photocathode. One drawback of the ion barrier is that it reduces the signal-to-

noise ratio of the image intensifier. This is due to the fact that the barrier prevents low energy electrons from reaching the microchannel plates.

Therefore, current image intensifiers require an ion barrier since current manufacturing techniques fail to remove enough gas molecules. But the presence of the ion barriers reduces the signal-to-noise ratio. What is needed is an unfilmed microchannel plate that has a sufficient number of gas ions removed such that an image intensifier manufactured with such a microchannel plate has a usable life.

Modern image intensifier tubes also provide automatic brightness control (ABC) and bright source protection (BSP). ABC maintains a relatively constant level of brightness in the image produced by the image intensifier tube despite fluctuating levels of brightness in the scene being viewed. BSP prevents the image intensifier tube from being damaged by high levels of current that may otherwise be generated in response to an extremely bright source.

Conventional image intensifier tubes provide ABC and BSP by adjusting the voltage level of the microchannel plate. Thus, for a brighter scene, the voltage to the microchannel plate is reduced. A drawback to this approach is that the image intensifier tube loses resolution as the voltage to the microchannel plate is reduced. What is needed is an image intensifier tube that provides ABC and BSP without a loss in resolution as the brightness increases.

SUMMARY OF THE INVENTION

In accordance with the present invention, the disadvantages and problems associated with previous image intensifiers have been substantially reduced or eliminated. In particular, the present invention provides a method and system for enhanced vision employing an improved image intensifier and gated power supply.

In one embodiment, a method is provided for detecting photons and generating a representation of an image. A photocathode receives photons from an image. A power supply to the photocathode is gated such that the photocathode is switched between an on state and an off state. The photocathode discharges electrons in response to the received photons while the photocathode is in the on state. A microchannel plate with an unfilmed input face and an output face receives the electrons from the photocathode and produces secondary emission electrons which are emitted from the output face. A screen receives the secondary electrons and displays a representation of the image.

Technical advantages of the present invention include providing an image enhancer with improved automatic brightness control and bright source protection. In particular, an image enhancer provides automatic brightness control and bright source protection without a significant loss in resolution as brightness increases.

Other technical advantages of the present invention will be readily apparent to those skilled in the art from the following figures, descriptions and claims.

BRIEF DESCRIPTION OF THE DRAWINGS

For a more complete understanding of the present invention, the objects and advantages thereof, reference is now made to the following descriptions taken in connection with the accompanying drawings in which:

FIG. 1 is a schematic design of an image intensifier in accordance with the teachings of the present invention

FIG. 2 illustrates an image intensifier tube in accordance with the teachings of the present invention;

FIG. 3 illustrates a microchannel plate in accordance with the teachings of the present invention;

FIG. 4 is a flowchart illustrating the formation of an enhanced image device utilizing an unfilmed microchannel plate; and

FIG. 5 is a schematic drawing illustrating a gated power supply for an image intensifier tube in accordance with one embodiment of the present invention.

DETAILED DESCRIPTION OF THE DRAWINGS

The preferred embodiment of the present invention and its advantages are best understood by referring to FIGS. 1 through 5 of the drawings, like numerals being used for like and corresponding parts of the various drawings.

FIG. 1 is a schematic design of an image intensifier 10 in accordance with the teachings of the present invention. Image intensifier 10 is operable to receive photons from an image and transform them into a viewable image. Image intensifier 10 is designed to operate and enhance viewing in varying light conditions including conditions where a scene is visible with natural vision and conditions where a scene is totally invisible with natural vision because the scene is illuminated only by star light or other infrared light sources. However, it will be understood that, although the image intensifier 10 may be used to enhance vision, the image intensifier 10 may also be used in other applications involving photon detection such as systems to inspect semiconductors.

Image intensifier 10 comprises optics 12 coupled to image intensifier tube 16. Power supply 18 is coupled to image intensifier tube 16. Image intensifier tube 16 also can include an image visualization means 20 for viewing the image produced by image intensifier 10.

Optics 12 are generally one or more lens elements used to form an objective optical assembly. Optics 12 are operable to focus light from a scene on to image intensifier tube 16.

Power supply 18 is operable to provide power to components of image intensifier tube 16. In a typical embodiment power supply 18 provides continuous DC power to image intensifier tube 16. The use of power supply 18 is further described in conjunction with FIG. 2.

Electronics 14 represents the other electronic necessary for image intensifier 10. These include electronics that are used to control among other things, power supply 16.

Image visualization means 20 is operable to provide a convenient display for images generated at image intensifier tube 16. Display 20 may be as simple as a lens or can be a cathode ray tube (CRT) display.

FIG. 2 illustrates an image intensifier tube 16 in accordance with the teachings of the present invention. Image intensifier tube 16 comprises a photocathode 22 having an input side 22a and an output side 22b. Coupled to photocathode 22 is a microchannel plate (MCP) 24 having an MCP input side 24a and an MCP output side 24b. A first electric field 23 is located between photocathode 22 and microchannel plate 24. Also included is a phosphorous screen 26 coupled to microchannel plate 24. Between phosphorous screen 26 and microchannel plate 24 is a second electric field 25.

In operation, photons from an image impinge on input side of photocathode 22a. Photocathode 22 converts photons into electrons, which are emitted from output side of photocathode 22b in a pattern representative of the original image. Typically, photocathode 22 is a circular disk like structure manufactured from semiconductor materials

mounted on a substrate as is well known in the art. One suitable arrangement is gallium arsenide (GaAs) mounted on glass, fiber optics or similarly transparent substrate.

The electrons emitted from photocathode 22 are accelerated in first electric field 23. First electric field 23 is generated by power supply 18. After accelerating in first electric field 23, the electrons impinge on the input side 24a of microchannel plate 24. Microchannel plate 24 typically comprises a thin glass wafer formed from many hollow fibers, each oriented slightly off axis with respect to incoming electrons. Microchannel plate 24 typically has a conductive electrode layer disposed on MCP input side 24a and MCP output side 24b. A differential voltage, supplied by power supply 18, is applied across the MCP input 24a and MCP output 24b. Electrons from photocathode 22 enter microchannel plate 24 where they produce secondary electrons, which are accelerated by the differential voltage. The accelerated secondary electrons leave microchannel plate 24 at MCP output 24b.

As discussed earlier, typical current microchannel plates contain an ion barrier on the input side in order to protect the photocathode from positive ions that travel from the MCP to the photocathode. These ions are typically gas ions trapped in the glass of the microchannel plate during processing. These ions are usually large and can cause physical and chemical damage to the photocathode if liberated from the microchannel plate and allowed to strike the photocathode. For conventional microchannel plates this problem leads to a very short image intensifier life (260 to 300 hours) when the ion barrier is not present. However, as discussed earlier, the ion barrier reduces the signal to noise ratio of image intensifier 10.

In the present invention, a microchannel plate without an ion barrier is provided for use in an image intensifier. In the present invention, even though the microchannel plate has no ion barrier, the life of the image intensifier is long (over 7,500 hours). Additionally, the signal to noise ratio is also very large (at least 27 to 1). This is achieved by providing a microchannel plate that is practically free from harmful ions.

After exiting microchannel plate 24 and accelerating in second electric field 25, secondary electrons impinge on phosphorous screen 26, where a pattern replicating the original image is formed. Other ways of displaying an image such as using a charged coupled device can also be used.

FIG. 3 illustrates a microchannel plate 24 in accordance with the teachings of the present invention. Illustrated is microchannel plate 24 comprising microchannel plate channels 30 and glass borders 32. As is illustrated in FIG. 3, incoming electrons 34 produce secondary emission electrons 36 by interactions in MCP 24.

In the present invention MCP input side 24a does not have an ion barrier film applied. The cladding glass used to manufacture microchannel plate 24 is made electrically conductive to produce secondary emission electrons and can be scrubbed to substantially reduce the amount of damaging ions. An example of suitable cladding glass is disclosed in U.S. Pat. No. 5,015,909, issued to Circon Corporation on May 14, 1991 and entitled "Glass composition and method for manufacturing a high performance microchannel plate". Other similar cladding glass material can also be used. As discussed earlier, each face (MCP input side 24a and MCP output side 24b) are made to act as electrodes. This is done by depositing a metallic coating such as Nichrome on the MCP input side 24a and MCP output side 24b. The channels are treated in such a way that incoming electrons produce

secondary emission electrons. This is typically done by forming a semi-conducting layer in channels **30**. The manufacture of a microchannel plate sufficiently low in ions such that it can be used unfilmed in an image intensifier is discussed in conjunction with FIG. 4.

FIG. 4 is a flowchart illustrating the formation of an enhanced image device utilizing an unfilmed microchannel plate. In Step **100**, a microchannel plate is formed. Microchannel plates are typically formed using a draw/multidraw technique in which many individual tubes are drawn (pulled) along a long axis several times to reduce the width of the tubes. The tubes are then sliced into individual microchannel plates.

In Step **102**, the microchannel plate is baked in a vacuum to drive off ions, such as gas ions, in the microchannel plate. In Step **104**, the phosphorus screen or CCD is prepared. In Step **106**, the screen is scrubbed to remove unwanted gas impurities such as carbon dioxide, carbon monoxide, hydrogen gas and other impurities. In Step **108**, the MCP and screen are placed together in a ceramic or metal input body to form a tube assembly.

In Step **110**, a photocathode is formed. The photocathode is typically formed from a semiconductor with GaAs or InGaAs layer on a transparent substrate.

In Step **114**, the tube assembly undergoes an electron beam scrub. The electron beam scrub uses a high-energy electron beam to drive out gas impurities that might later contribute to damaging ions. Typically a high intensity electron beam scrub is done over a long period of time.

One drawback to such an electron beam scrub of an unfilmed microchannel plate is that the intensity maybe such that the electrons leaving the MCP could burn a hole, or other wise damage, the phosphorous screen. To avoid this, the focus of the electron beam must be set to diffuse the high energy electrons before they reach the screen.

In Step **116**, the tube assembly goes through a cesiation process. Cesium is a good gas eliminator (also known as a gas getter) which is used to remove even more gas based impurities from the screen and microchannel plate.

In Step **118**, the photocathode undergoes a heat cleaning and a cesium activation step. In the heat cleaning step, the photocathode is heated in a vacuum to drive off any oxide layers. Next, a cesium activation step is performed. This is done to form a cesium and oxygen layer on top of the photocathode to protect the photocathode. This is done using a conventional process, which exposes the photocathode to cesium until an optimal amount of cesium is placed on the photocathode.

After Steps **116** and **118**, the MCP/screen elements are assembled together in step **120**. In Step **122**, a wire of Ti/Ta is used as a final gas getter to remove any last impurities. After this is completed, the tube is tested in Step **124**, after which the final tube assembly occurs in Step **126**.

FIG. 5 is a schematic drawing illustrating a gated power supply **18** for an image intensifier **10** in accordance with one embodiment of the present invention. The gated power supply **18** provides a relatively constant brightness for the image seen by a user of the image intensifier **10**. The power supply **18** comprises a power source **202** which is illustrated in FIG. 5 as a battery. It will be understood, however, that the power source **202** may comprise a regulated line power source or other suitable source of power.

The power supply **18** comprises three voltage multipliers **204**, **206** and **208**. These include a photocathode multiplier **204**, an MCP multiplier **206** and a screen multiplier **208**. The

photocathode multiplier **204** comprises a positive photocathode multiplier **210** and a negative photocathode multiplier **212**. The positive photocathode multiplier **210** provides a voltage level that is positive with respect to the input **24a** of the MCP **24**, and the negative photocathode multiplier **212** provides a voltage that is negative with respect to the input **24a** of the MCP **24**.

The photocathode **22** may be coupled to a tri-stable switching network **214** through a conductor **216**. The switching network **214** may couple the photocathode **22** to the positive photocathode multiplier **210** or to the negative photocathode multiplier **212**. In addition, the photocathode **22** may be in an open circuit position in which the conductor **216** terminates in an open circuit within the switching network **214**. As an alternative, the switching network **214** may be configured to switch between the positive photocathode multiplier **210** and the negative photocathode multiplier **212** without an open circuit position being available.

A duty cycle control **218** receives a square wave gating trigger signal from an oscillator **220** and a control signal through a conductor **222** from an ABC/BSP control circuit **224**. The duty cycle control **218** controls the position of the switch within the switching network **214**. Thus, the duty cycle control **218** determines whether the photocathode **22** is coupled to the positive photocathode multiplier **210**, the negative photocathode multiplier **212**, or the open circuit position.

Power is supplied to the MCP **24** from the MCP multiplier **206** through lines **226** and **228**. In one embodiment, line **226** includes a series element **230** that is coupled between the MCP multiplier **206** and the MCP **24**. In an alternative embodiment, however, line **226** does not include the series element **230**. The series element **230** may be a variable resistor, such as a high voltage MOSFET. The resistance of the series element **230** is controlled through a conductor **232** by a regulator circuit **234**. The regulator circuit **234** receives a feedback control signal from a summing junction **236**. The summing junction **236** receives an input from a level adjusting resistor **238** through a conductor **240** and an input from the ABC/BSP control circuit **224** through a conductor **242**. The conductor **240** also provides to the photocathode multiplier **204** a feedback signal of the voltage level at the input **24a** of the MCP **24**.

The screen multiplier **208** is coupled to the screen **26** through a conductor **244** and provides to the ABC/BSP control circuit **224** a feedback of the current level of the screen **26** through lines **246**. An oscillator **248** provides energy flow to the power supply **18** through a transformer **250**. The transformer **250** provides energy to the photocathode multiplier **204** and the screen multiplier **208** through output windings **252** and to the MCP multiplier **206** through a conductor **254**. The oscillator **248** receives a control feedback from a regulator **256** and a feedback circuit **258** that has an input from a feedback winding **260** of the transformer **250**.

In operation, the photocathode **22** functions as described above in connection with FIG. 2 when the switch in the switching network **214** couples the photocathode **22** to the negative photocathode multiplier **212**. In this configuration, the power supply **18** provides a constant negative voltage to the photocathode **22** through the negative photocathode multiplier **212**. In one embodiment, this voltage level is approximately -800 volts. However, when the switch in the switching network **214** couples the photocathode **22** to the positive photocathode multiplier **210**, the photocathode **22** is no longer responsive to photons and is essentially forced

into a non-functioning state. In this configuration, the power supply 18 provides a constant positive voltage to the photocathode 22 through the positive photocathode multiplier 210. In one embodiment, this voltage level is approximately +30 volts with reference to the input 24a of the MCP 24.

Therefore, the power supply 18 provides a gating function by turning the photocathode 22 on and off at specified intervals such that the current or voltage level of a particular component is kept within a specified range. The length of these specified intervals is controlled by the duty cycle control 218. In one embodiment, the duty cycle control 218 determines the interval based on the current level of the screen 26. Alternatively, the duty cycle control 218 determines the interval based on the current level at the output 24b of the MCP 24. It will be understood, however, that the length of the specified intervals may be based on current or voltage levels of other suitable components of the image intensifier tube 16.

For the embodiment in which the interval is based on the current level of the screen 26, the power supply 18 provides continuous power to the photocathode 22 through the negative photocathode multiplier 212 until the current level of the screen 26 reaches a peak value. At that point, the duty cycle control 218 begins to switch the switching network 214 at a specified interval in order to maintain the current level of the screen 26 below the peak value. The specified interval is the amount of time that the photocathode 22 is in an off state. For example, the duty cycle control 218 may place the photocathode 22 in an on state by coupling to the negative photocathode multiplier 212. The photocathode 22 is later placed in an off state by coupling to the positive photocathode multiplier 210. After the specified interval has passed, the photocathode 22 is again placed in an on state by coupling to the negative photocathode multiplier 212, and the cycle continues.

As the current level of the screen 26 attempts to rise farther above the peak value, the duty cycle control 218 lengthens the interval to maintain the current level of the screen 26. However, the interval may reach a maximum length after which the duty cycle control 218 may not continue to lengthen the interval. In one embodiment, the duty cycle control 218 provides an interval that allows the photocathode 22 to operate between about 10⁻⁴% and 100% of the time. Thus, the duty cycle control 218 may not lengthen the interval beyond the point at which the photocathode 22 is on for only about 10⁻⁴% of the time.

Once the interval has reached this maximum length, the power supply 18 may compensate for the rising current level of the screen 26 by decreasing the voltage level applied to the MCP 24. This may be accomplished by the MCP regulator 234 increasing the resistance of the series element 230. As described above, the MCP regulator 234 receives input from the level adjusting resistor 238 and the ABC/BSP control circuit 224, which is responsive to the current level of the screen 26 by way of lines 246.

When the duty cycle control 218 is gating the power to the photocathode 22 at a specified interval, the voltage provided at the photocathode 22 alternates between the negative voltage provided by the negative photocathode multiplier 212 and the positive photocathode multiplier 210. However, the voltage at the photocathode 22 decays slightly when the switch in the switching network 214 moves from the negative photocathode multiplier 212 to the positive photocathode multiplier 210. Thus, when the switch is in an open circuit position, the voltage at the photocathode 22 begins to decay. This decay is relatively small because of the capaci-

tance between the photocathode 22 and the MCP 24, illustrated in FIG. 5 as a virtual capacitor 262.

While the invention has been particularly shown and described by the foregoing detailed description, it will be understood by those skilled in the art that various other changes in form and detail may be made without departing from the spirit and scope of the invention.

What is claimed is:

1. A method for detecting photons and generating a representation of an image, comprising:

receiving photons from the image at a photocathode; gating a power supply to the photocathode such that the photocathode is switched between an on state and an off state;

discharging electrons from the photocathode in response to the received photons while the photocathode is in the on state;

accelerating electrons towards an unfilmed input face of a microchannel plate, the unfilmed input face free of an ion barrier film;

receiving electrons at the unfilmed input of the microchannel plate;

generating secondary emission electrons in the microchannel plate in response to the received electrons;

discharging the secondary emission electrons from an output face of the microchannel plate;

accelerating secondary emission electrons to a screen; and displaying a representation of the image at the screen.

2. The method of claim 1, further comprising discharging no electrons from the photocathode in response to received photons while the photocathode is in the off state.

3. The method of claim 1, wherein the photocathode and the microchannel plate are provided as part of an image intensifier tube.

4. The method of claim 3, wherein the image intensifier tube is used for night vision devices.

5. The method of claim 3, wherein the image intensifier tube has a lifetime of at least 7,500 hours.

6. A device for photon detection and image generation, comprising:

a photocathode operable to receive photons from an image;

a gated power supply operable to switch the photocathode between an on state and an off state, wherein the photocathode is operable to discharge electrons in response to the received photons while in the on state and operable to discharge no electrons in response to the received photons while in the off state;

a microchannel plate having an unfilmed input face and an output face, the unfilmed input face free of an ion barrier film, the microchannel plate receiving the electrons from the photocathode and producing secondary emission electrons in response, the secondary electrons emitting from the output face; and

a screen operable to receive the secondary emission electrons and display a representation of the image.

7. The device of claim 6, wherein the signal to noise ratio for the device is at least 27.

8. The device of claim 6, wherein the photocathode and the microchannel plate are provided as part of an image intensifier tube.

9. The device of claim 8, wherein the image intensifier tube is used for night vision devices.

10. The device of claim 8, wherein the lifetime of the image intensifier tube is more than 7,500 hours.

11. A device for photon detection and image generation, comprising:

a photocathode operable to receive photons from an image;

a gated power supply comprising:

a negative voltage source operable to generate a negative voltage,

a positive voltage source operable to generate a positive voltage, and

a switching network operable to alternatively couple the photocathode to the negative voltage source and the positive voltage source at a specified interval;

a microchannel plate having an unfilmed input face and an output face, the unfilmed input face free of an ion barrier film, the microchannel plate operable to receive the electrons from the photocathode and produce secondary emission electrons in response, the secondary electrons emitted from the output face; and

a screen operable to receive the secondary emission electrons and display a representation of the image.

12. The device of claim **11**, wherein the negative voltage source and the positive voltage source comprise voltage multipliers.

13. The device of claim **11**, wherein the switching network is further operable to place the photocathode in an open circuit position.

14. The device of claim **11**, the power supply further comprising a duty cycle control coupled to the switching

network, the duty cycle control operable to control the switching network.

15. The device of claim **14**, wherein the duty cycle control switches the photocathode from the negative voltage source to the positive voltage source at a specified interval.

16. The device of claim **15**, wherein the duty cycle control determines the specified interval based upon a current level of the phosphorous screen.

17. The device of claim **15**, wherein the duty cycle control determines the specified interval based upon a current level of the microchannel plate.

18. The device of claim **15**, the power supply further operable to reduce a voltage level applied by a microchannel plate voltage source to the microchannel plate in response to the specified interval reaching a maximum length.

19. The device of claim **18**, the power supply further comprising a variable impedance element coupled between the microchannel plate voltage source and the microchannel plate and wherein the power supply is operable to reduce the voltage level by increasing an impedance of the variable impedance element.

20. The device of claim **18**, wherein the power supply is operable to reduce the voltage level by reducing the voltage level based on a current level of the phosphorous screen.

* * * * *