



US006287334B1

(12) **United States Patent**  
**Moll et al.**

(10) **Patent No.:** **US 6,287,334 B1**  
(45) **Date of Patent:** **Sep. 11, 2001**

(54) **DEVICE FOR REGULATING THE FLOW OF BLOOD THROUGH THE BLOOD SYSTEM**

(75) Inventors: **Franciscus Laurens Moll**, Bosch en Duin; **Menno Kalmann**, Elsp-eet, both of (NL)

(73) Assignee: **VenPro Corporation**, Irvine, CA (US)

(\* ) Notice: Subject to any disclaimer, the term of this patent is extended or adjusted under 35 U.S.C. 154(b) by 0 days.

(21) Appl. No.: **08/992,350**

(22) Filed: **Dec. 17, 1997**

(30) **Foreign Application Priority Data**

Dec. 18, 1996 (NL) ..... 1004827

(51) **Int. Cl.**<sup>7</sup> ..... **A61F 2/06**

(52) **U.S. Cl.** ..... **623/1.24; 623/23.64; 623/23.68; 623/23.7; 128/898**

(58) **Field of Search** ..... 623/2, 1, 11, 66, 623/12, 900, 1.1, 1.11, 1.24, 1.26, 2.1, 23.64, 23.68, 23.7; 128/898; 251/358

(56) **References Cited**

**U.S. PATENT DOCUMENTS**

- 4,291,420 \* 9/1981 Reul ..... 623/2
- 4,787,901 \* 11/1988 Baykut ..... 623/2
- 5,141,491 8/1992 Bowald .
- 5,327,774 7/1994 Nguyen et al. .
- 5,332,402 \* 7/1994 Teitelbaum ..... 623/2
- 5,411,552 5/1995 Andersen et al. .

- 5,480,423 1/1996 Ravenscroft et al. .
- 5,713,953 \* 2/1998 Vallana et al. .... 623/2
- 5,735,859 4/1998 Fischell et al. .
- 5,741,326 4/1998 Solovay .
- 5,741,333 4/1998 Frid .
- 5,800,506 \* 9/1998 Perouse ..... 623/1
- 5,824,061 10/1998 Quijano et al. .

**FOREIGN PATENT DOCUMENTS**

- 1932817 1/1970 (DE) .
- 19532846 3/1997 (DE) .
- 0667133 8/1995 (EP) .
- 1477643 6/1977 (GB) .
- 9619159 6/1996 (WO) .

\* cited by examiner

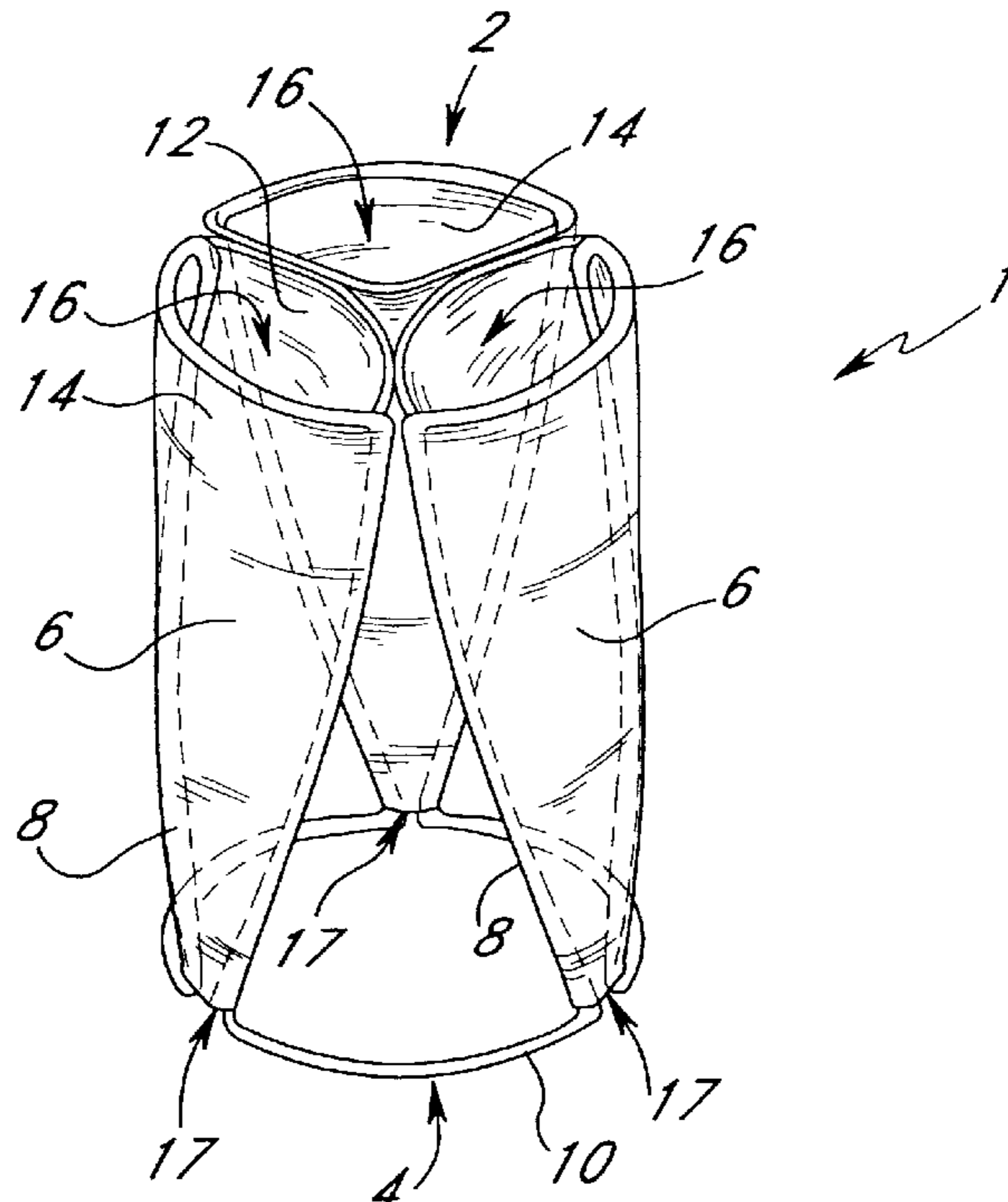
*Primary Examiner*—Dinh X. Nguyen

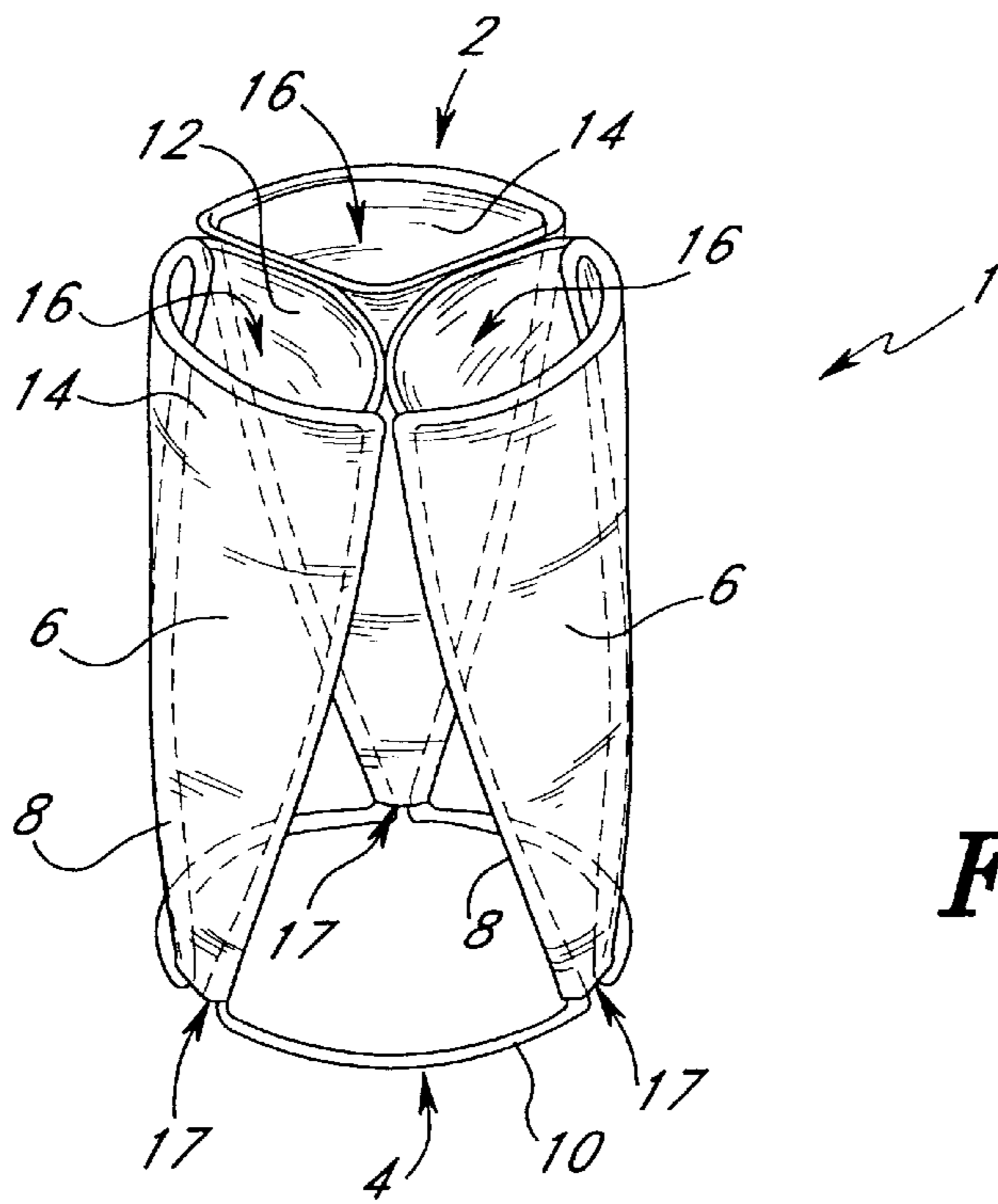
(74) *Attorney, Agent, or Firm*—Knobbe, Martens, Olson & Bear, LLP

(57) **ABSTRACT**

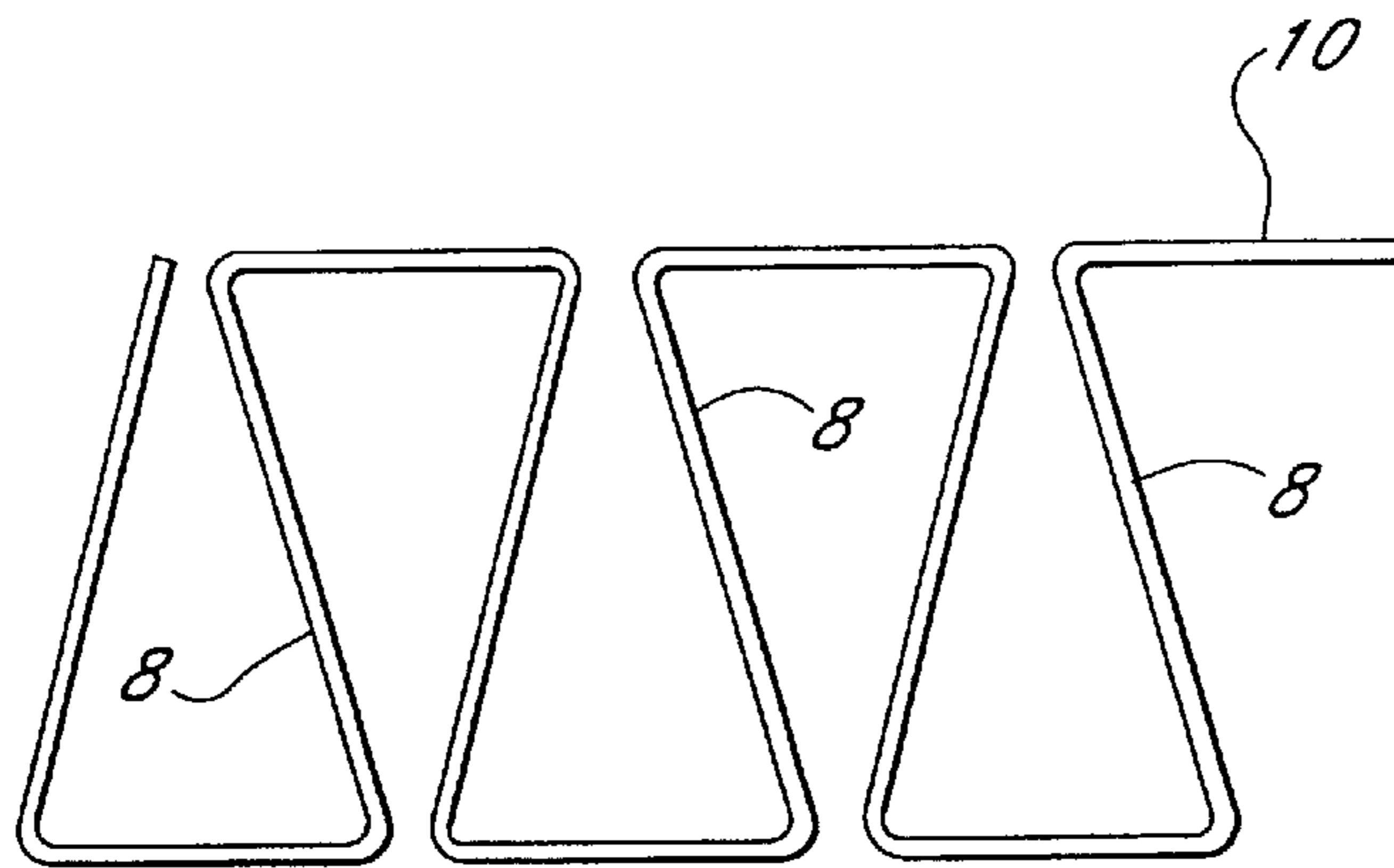
A valve prosthesis is disclosed which is implantable within a vein or other blood vessel of a patient using a minimally-invasive surgical procedure. The prosthesis includes a tubular wire frame which presses radially outward against the inner walls of the blood vessel following implantation to hold the prosthesis in position. Multiple flow-resistive pockets that open and close in response to changes in blood flow direction are attached to the frame to impede the flow of blood in the reverse direction. The prosthesis is implanted using an introducer catheter which holds the prosthesis in a radially-compressed state as the prosthesis is inserted into and positioned within the blood vessel.

**15 Claims, 3 Drawing Sheets**

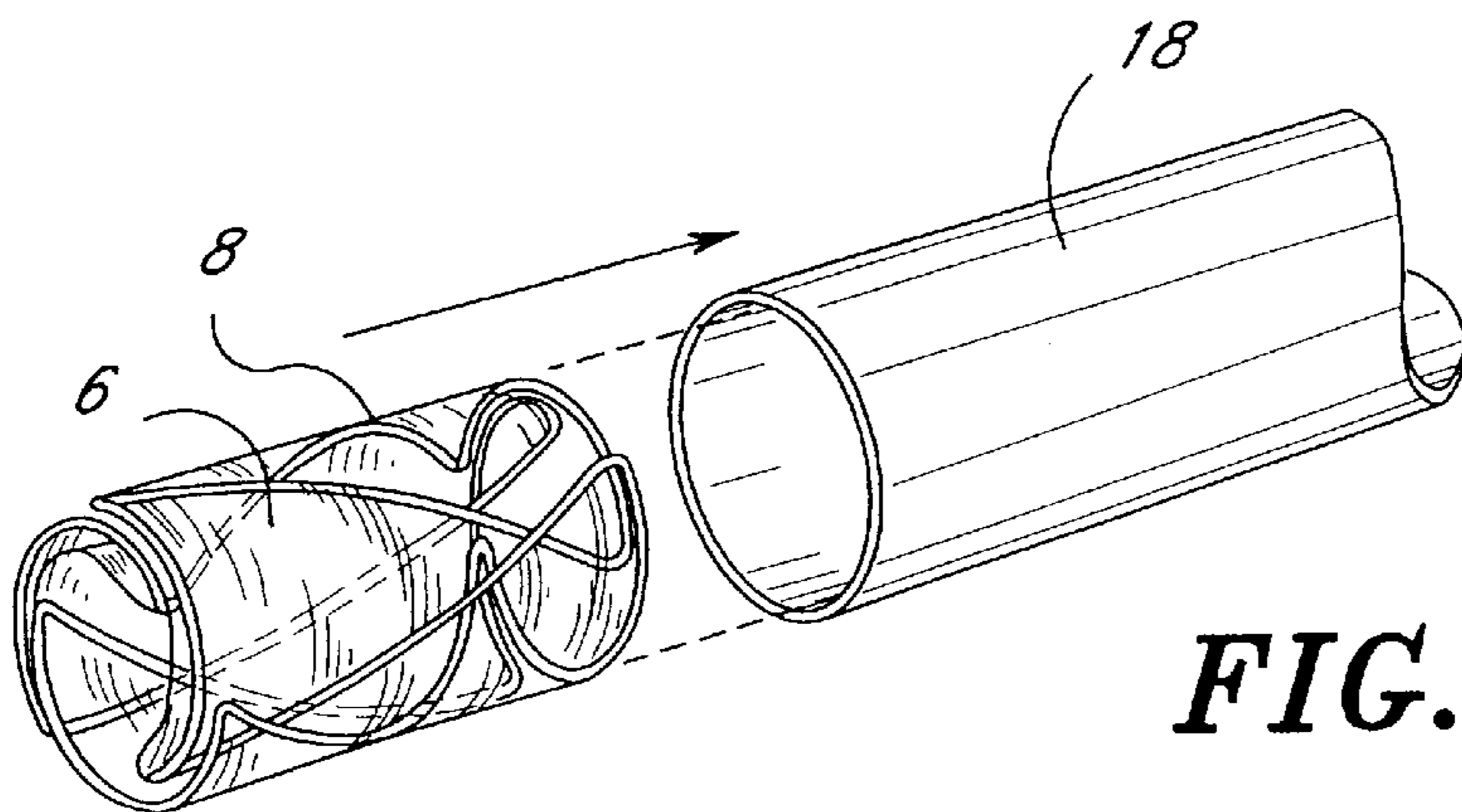




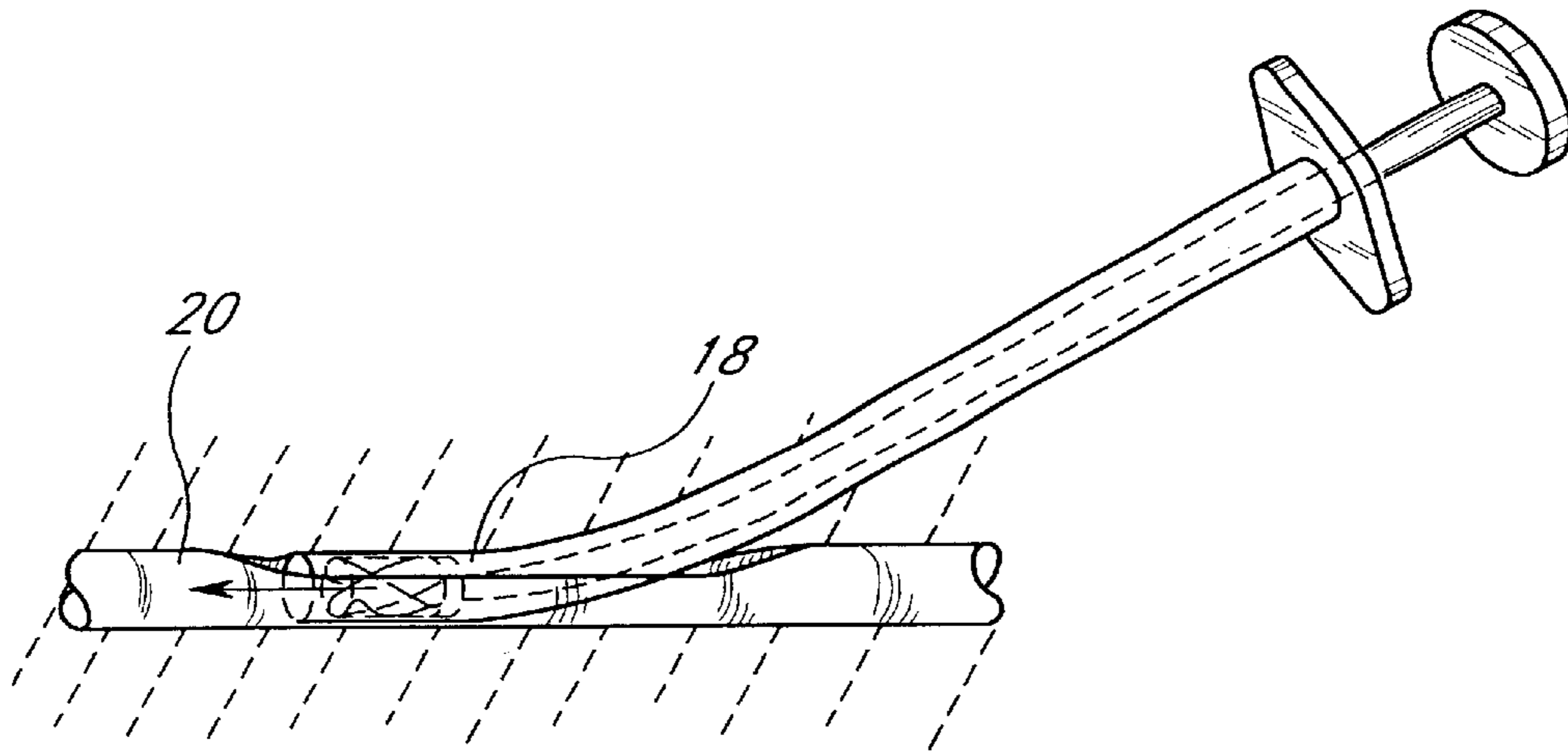
**FIG. 1**



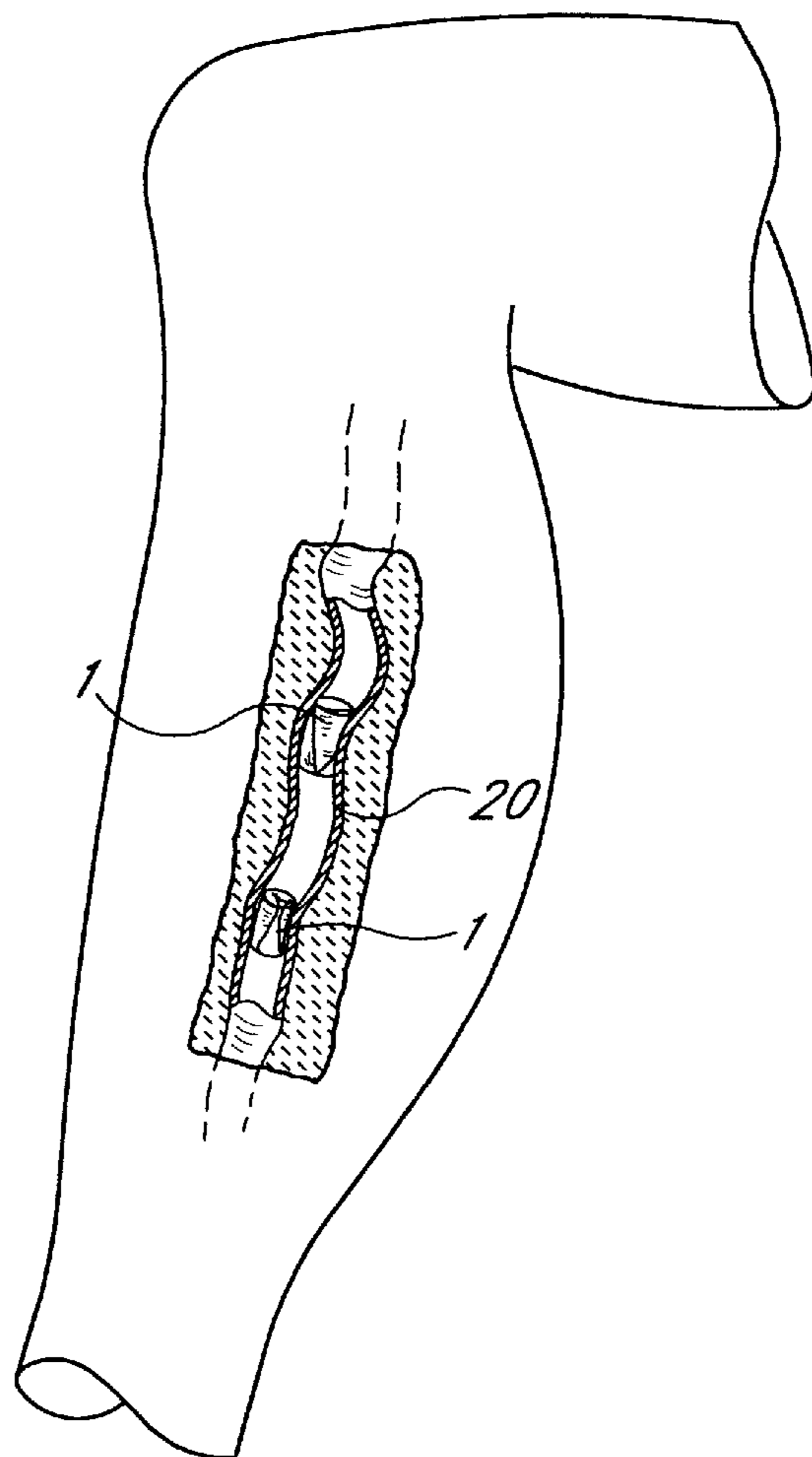
**FIG. 2**



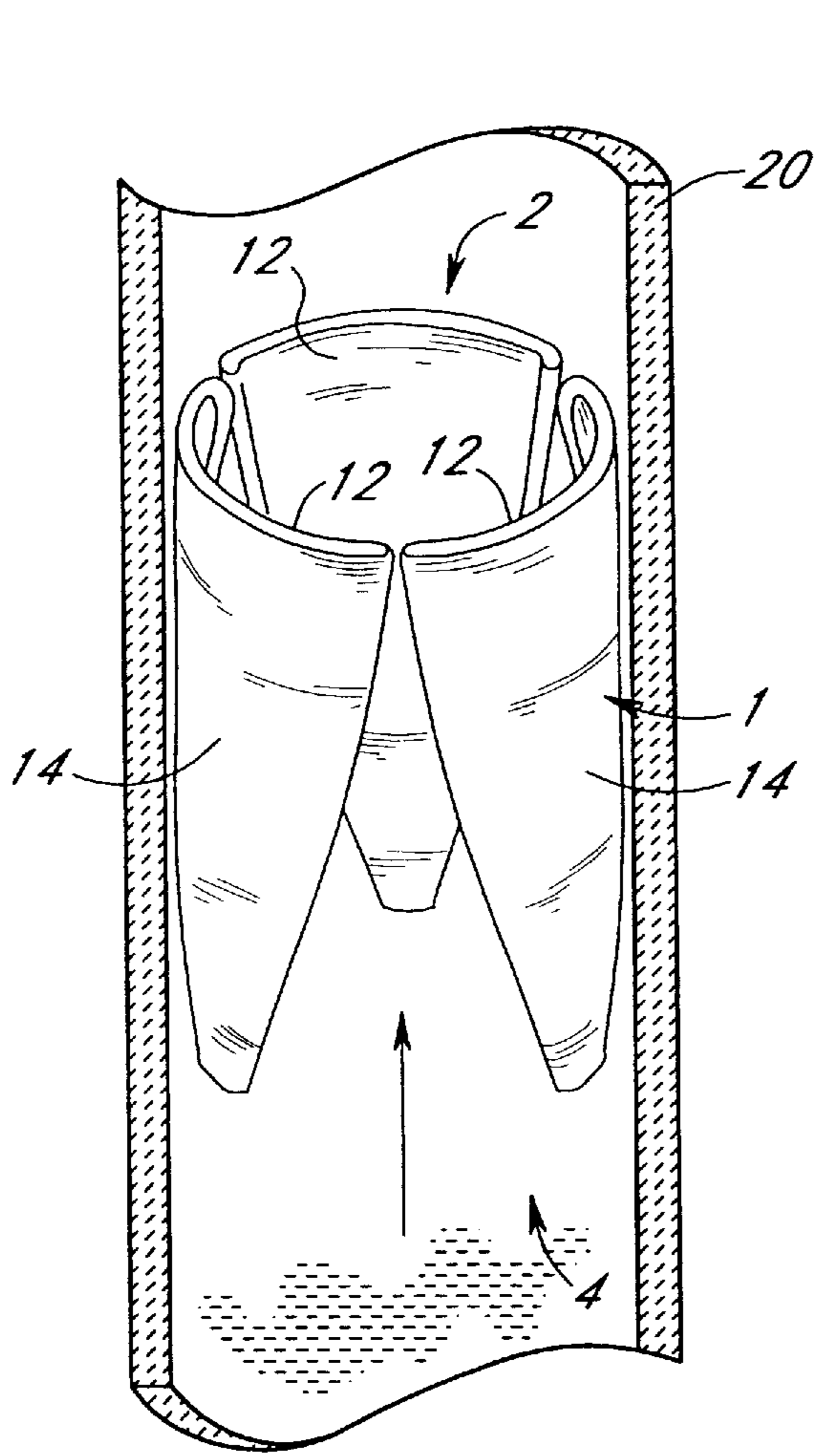
**FIG. 3**



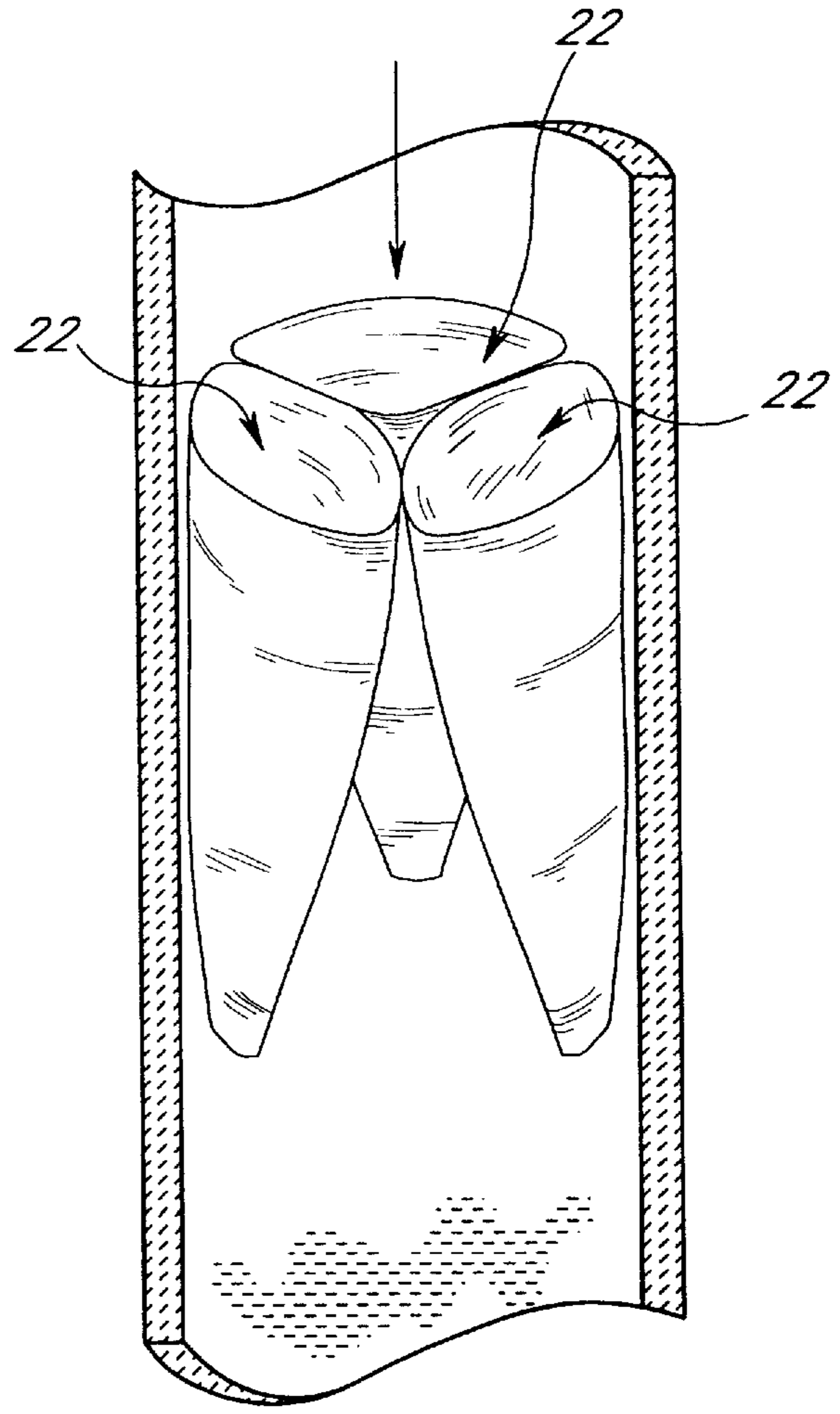
**FIG. 4**



**FIG. 7**



**FIG. 5**



**FIG. 6**

## DEVICE FOR REGULATING THE FLOW OF BLOOD THROUGH THE BLOOD SYSTEM

This application claims priority to Dutch Patent Application Number 1004827, filed Dec. 18, 1996.

The present invention relates to a device for regulating the flow of blood in blood vessels.

The blood system, and in particular the venal blood system of the legs and arms are provided with valves, at predetermined positions, which ensure that blood cannot flow back along the system in the direction from which it has just been pumped, to only be displaced in the direction of the heart.

In the arms and legs, there is a deep and a surface venal system.

Due to various causes, thrombosis can occur in especially the deep venal system. Following thinning of the blood, passage of the blood through the system is often again possible, but in this case the valves do not effectively close off the system and often leak. This causes an increased venal blood pressure in the direction of the ankles, which leads to many problems, such as varicose veins and the infamous "open leg". This type of complaint, is wide spread among people who spend a vast majority of their working hours in a standing position, for instance surgeons.

The surface venal system of the leg is weaker than the deep system, and has the tendency to spontaneously widen, whereby the valves no longer function effectively, leading to varicose veins, which, apart from being highly unattractive, are also very painful. Major surgery is often required to deal with these blood vessel valve problems.

For example varicose veins are presently surgically operated on, by either closing off the vein, which leads to a reduced blood flow capacity and extra pressure on surrounding blood vessels in order to ensure blood supply, or by completely removing the varicose veins, which leads to the same problem.

An object of the present invention is to obviate one or more of these problems.

According to a first aspect, the present invention provides a device for regulating the flow of blood in blood vessels, comprising one or more flow stoppage elements, each comprising:

- a flareable proximal end, flareable between a flared, flow stoppage configuration and a substantially flattened, flow permitting configuration, and
- a middle section extending from the proximal end to terminate in a distal end.

By introducing a synthetic device which acts as a valve, the blood flow is now able to be regulated in substantially the normal manner.

The device preferably further comprises:

- an opening associated with the proximal end, the middle section comprising one or more sidewalls extending from this proximal end opening to join together at the distal end, the sidewalls being displaceable, by the flow of blood through the device between the flared configuration, wherein the element encloses a temporary blood storage area, and the substantially flattened configuration wherein the one or more sidewalls lie substantially flat adjacent to each other.

When occupying the blood flow stoppage configuration, the flow stoppage element encloses a temporary blood storage area between its open proximal end and the closed distal end. In this way between heartbeats, which force the blood through the venal system, any blood flowing in the opposite direction to the blood stream opens the proximal

end of the stoppage element thereby forcing the sidewalls apart to enter the temporary blood storage area, instead of passing through the device to leak back into the blood vessel in the direction from where it has just been pumped. Since opening of the blood flow stoppage element effectively closes off the blood vessel, a very effective valve is provided.

The flow stoppage element is preferably mounted on a support having such a form as to pass within a blood vessel. This provides extra stability.

Further, the support frame comprises a resilient wire and is biased toward an unrolled configuration.

The stoppage element is preferably substantially conical in shape when occupying the blood flow stoppage configuration, the closed distal end being synonymous with the tip of the cone and the proximal end opening being synonymous with the flared base of the cone. This yields a highly effective valve working.

The support is preferably adjustable between an introducing form, wherein the device is suitable for introducing into a blood vessel, and an expanded form suitable for supporting the stoppage element within a blood vessel at the desired working location thereof, and most preferably has such a form as to have substantially the same length when occupying its introducing form as when occupying its expanded form. Accordingly the device can be effectively introduced to a pre-desired location within a blood vessel, whereafter it is expandable to take up its working form. Since the support has substantially the same length when in its introducing form as in its expanded form, the stoppage elements remain effectively supported, and any damage ensuing from alteration of the length of the support within the blood system is effectively obviated.

In order to yield a very effective valve working, the support preferably comprises substantially separate frame sections for each of the one or more fluid passage stoppage elements.

According to another aspect of the present invention, there is provided a support for a fluid stoppage element as referred to above.

According to yet a further aspect of the present invention there is provided a method for regulating the flow of blood in the blood stream comprising introducing the above device into a blood vessel, so that the distal end thereof is arranged downstream from the proximal end, wherein the proximal end opening is closed by the pressure of blood flowing through the device, as blood is pumped through the system by the heart, wherein blood flowing in the opposite direction to which it is pumped between beats, flows into the proximal end of the device, which is subsequently thereby opened to force the sidewalls of the device against the blood vessel walls, thereby closing off the passage of blood in the blood vessel, wherein blood is trapped in the temporary blood storage area enclosed by the sidewalls of the device before a subsequent volume of blood being pumped through the device claps said sidewalls shut, thereby expelling blood out of the temporary storage area and further through the system.

The introducer preferably comprises an elongated sliding member which is advanceable by a physician to forcibly displace the valve prosthesis from the hollow distal portion of said introducer into the blood vessel

The present invention will now be further clarified by way of the following specific description, which refers to FIGS. 1 to 7, wherein:

FIG. 1 is a perspective view of the device according to the present invention;

FIG. 2 is a side view of a support for a flow stoppage element according to the present invention,

FIG. 3 is a perspective view of the device from FIG. 1, when occupying its introducing form, as to be introducible into a blood vessel;

FIG. 4 is a perspective view showing the introduction of a device as shown in FIG. 1 into a blood vessel;

FIG. 5 is a perspective view as in FIG. 4, showing the device when occupying its blood flow through put position;

FIG. 6 shows the device from FIG. 1, with the support (not shown) in order to provide maximum clarity, when occupying its blood flow stoppage position within a blood vessel; and

FIG. 7 is a perspective view of two devices as shown in FIG. 1, when placed in a vein in the leg.

A device 1 (FIG. 1) according to the present invention has a proximal end 2 and a distal end 4.

Blood flow stoppage elements 6, having the form of flexible hollow cones, are each supported on a substantially triangular frame section 8 of a support 10, see also FIG. 2.

The valve elements 6 have an inner wall 12 and an outer wall 14 extending from a proximal end (2) opening 16 in the "flared" configuration to join together and terminate in the form of a pointed end section 17 at the distal end 4.

The support 10 is preferably made of a continuous length of memory metal, having, as shown in FIG. 1 and 2, three substantially separate frame sections 8 for supporting each valve element 6.

As shown in FIG. 3, the frame 10 can be rolled up so that frame sections 8 partially overlap one another.

In such a position the device 1 is easily introduced into a blood vessel.

On being placed at its desired position within the blood system, the device, once the memory metal has achieved a particular predetermined temperature, will expand in order to assume its working form as shown in FIG. 1, whereby since in its introducing form (FIG. 3), an area of overlap exists between the terminal frame sections 8, the device 1 remains substantially the same length in its working position (FIG. 1) as in its introducing position (FIG. 3).

In order to ensure biocompatibility, the support and blood stoppage elements are made of biocompatible material, whereby the blood stoppage elements are most preferably made of polytetrafluoroethylene (PTFE).

The device 1 is folded up into its introducing form, as shown in FIG. 3, whereafter once arranged in an introducing device 18, as shown in FIGS. 3 and 4, the device 1 is introducible into a blood vessel 20 as shown in FIG. 4.

On assuming its working configuration as shown in FIGS. 1, 5, 6 and 7, the blood is regulated in the blood vessel by the device as follows.

Blood is pumped through the blood vessel 20 (FIG. 5) and through the device 1 (FIG. 5) on the beat of the heart. This means that instead of flowing at a constant rate through the blood vessel, that blood flows through the blood system, in particular through veins, as a series of pulses. Between each pulse, the blood is not being actively forced through the system and can flow back from where it came.

When actively pumped through the system, blood is forced through the device 1 through the distal end 4 and out of the proximal end 2 (FIG. 5).

In this position (FIG. 5), the flow of the blood through the device 1, forces the inner walls 12 of the stoppage elements 6 against the outer walls 14 thereof in order to effect a blood flow through channel.

Between heartbeats, blood having just passed through the proximal opening 2 of the device 1, can flow back down the

blood vessel 20. On doing so, it forces the inner walls 12 away from the outer walls 14 of these elements 6 at the proximal end 2 of the device 1 to create the opening 16 leading into a temporary blood storage area 22. Since the inner walls 12 and the outer walls 14 are joined together at the distal end 4 of the device, the temporary blood storage area 22 is effected in each blood stoppage element 6 at this phase (FIG. 6).

During the next pulse of blood through the device 1 from the distal end 4, the inner walls 12 are forced against the outer walls 14 of the stoppage elements 6, thus forcing the blood temporarily stored therein out of the blood stoppage elements 6 and effecting the open channel to enable blood through flow.

What is claimed is:

1. An implantable venous valve prosthesis device for regulating the flow of blood in a blood vessel of a patient, the device comprising:

a support frame which is configured to be positioned within a vein, wherein the support frame is configured to press outward against inner walls of the vein to hold the prosthesis device in place following implantation; and

at least one collapsible flow restriction pocket attached to the support frame, the flow restriction pocket comprising an inner wall and an outer wall, the inner wall being displaceable by the flow of blood through the vein such that the collapsible flow restriction pocket assumes a collapsed configuration wherein the inner wall is forced against the outer wall when blood flows through the vein in a forward direction, and assumes an open configuration wherein the inner wall is forced away from the outer wall when blood flows through the vein in a reverse direction;

wherein the flow restriction pocket impedes the flow of blood in the reverse direction when the flow restriction pocket is in the open configuration.

2. The valve prosthesis device as in claim 1, wherein the collapsible flow restriction pocket is configured to open and close within a vein of a human in response to blood flow at venous-level pressures.

3. The valve prosthesis device as in claim 1, wherein the collapsible flow restriction pocket has a generally conical shape when the flow restriction pocket is in the open configuration.

4. The valve prosthesis device as in claim 1, wherein the collapsible flow restriction pocket assumes a substantially flat, arcuate configuration which conforms to an inner surface of the vein when the flow restriction pocket is in the collapsed configuration.

5. The valve prosthesis device as in claim 1, wherein the support frame has a generally tubular configuration and is adapted to be compressed radially to a diameter which is less than an inner diameter of the vein during an implantation procedure, and wherein the frame automatically expands radially when the prosthesis device is deployed within the vein.

6. The valve prosthesis device as in claim 5, wherein the support frame comprises a generally flat wire frame which is rolled upon itself to assume the generally tubular configuration.

7. The valve prosthesis device as in claim 6, wherein the support frame comprises a resilient wire and is biased toward an unrolled configuration.

8. The valve prosthesis device as in claim 6, wherein the wire frame comprises a memory metal, and is preprogrammed to assume an expanded configuration within the vein at a predetermined temperature.

5

9. The valve prosthesis device as in claim 5, in combination with an introducer for implanting the valve prosthesis device within the vein using a minimally-invasive implantation procedure, the introducer comprising a hollow distal portion which is configured to receive the valve prosthesis device in a compressed form, the tubular distal portion configured to be advanced into the vein through an opening in the vein to position the valve prosthesis device within the vein.

10. The valve prosthesis device as in claim 9, wherein the introducer comprises an elongated sliding member which is advanceable by a physician to forcibly displace the valve prosthesis device from the hollow distal portion into the vein.

11. The valve prosthesis device as in claim 1, wherein a plurality of the collapsible flow restriction pockets are attached to the support frame.

12. A venous valve prosthesis which is adapted to restore venous valvular function within the vein of a human, the prosthesis comprising:

a generally tubular support member configured to be inserted within a vein, wherein the support member comprises a wire frame which is rolled upon itself to form the generally tubular configuration; and

at least one flow stoppage member attached to the support member and defining a temporary blood storage area within the support member, the temporary blood storage area having inner and outer walls adapted to open

6

and close in response to changes in a direction of blood flow through the vein.

13. The venous valve prosthesis as in claim 12, wherein the wire frame comprises a memory metal.

14. A venous valve prosthesis system which is adapted to restore venous valvular function within the vein of a human, the prosthesis comprising:

a generally tubular support member configured to be inserted within a vein;

at least one flow stoppage member attached to the support member and defining a temporary blood storage area within the support member, the temporary blood storage area having inner and outer walls adapted to open and close in response to changes in a direction of blood flow through the vein; and

an introducer for implanting the prosthesis within the vein using a minimally-invasive implantation procedure, the introducer comprising a hollow distal portion which is configured to receive the valve prosthesis in the radially-compressed state, the tubular distal portion configured to be advanced through an opening in the vein to position the prosthesis within the vein.

15. The venous valve prosthesis system as in claim 14, wherein the introducer comprises an elongated sliding member which is advanceable by a physician to forcibly displace the prosthesis from the hollow distal portion into the vein.

\* \* \* \* \*