



US006274020B1

(12) **United States Patent**
Schmidt et al.

(10) **Patent No.:** **US 6,274,020 B1**
(45) **Date of Patent:** **Aug. 14, 2001**

(54) **ELECTRODIALYSIS MEMBRANE AND GASKET STACK SYSTEM**

5,948,230 9/1999 McRae 204/524
5,972,191 10/1999 Mani 204/631

(76) Inventors: **Ernst Schmidt**, 5220 Arbor Way, Las Vegas, NV (US) 89107; **Michael E. Williams**, Rte. 5, Box 756, Albany, KY (US) 42605; **Brian M. Schmidt**, 5209 Clouds Rest Ave., Las Vegas, NV (US) 89108; **James Schmidt**, 9505 Cliff View Way, Las Vegas, NV (US) 89117; **Erich Schmidt**, 7115 Newland St., Arvada, CO (US) 80003

FOREIGN PATENT DOCUMENTS

60068009 4/1985 (JP) .

* cited by examiner

Primary Examiner—Kathryn Gorgos
Assistant Examiner—Thomas H Parsons
(74) *Attorney, Agent, or Firm*—Pitts & Brittan, P.C.

(*) Notice: Subject to any disclaimer, the term of this patent is extended or adjusted under 35 U.S.C. 154(b) by 0 days.

(21) Appl. No.: **09/561,049**

(22) Filed: **Apr. 28, 2000**

(51) **Int. Cl.**⁷ **B01D 61/46**

(52) **U.S. Cl.** **204/636; 204/638; 204/639**

(58) **Field of Search** 204/633, 636, 204/638, 639

(56) **References Cited**

U.S. PATENT DOCUMENTS

3,223,612 * 12/1965 Chen et al. 204/301
3,235,481 * 2/1966 Zwart 204/301
3,405,047 * 10/1968 Chen 204/280

(57) **ABSTRACT**

An apparatus and system of operation of an electro dialysis membrane and gasket stack for separation of components in liquid mixtures is disclosed. The system of operation for purification and deionizing liquids includes an operation of pretreatment by filtration for removal of inorganic contaminants, includes an operation of adsorption for removing organic contaminants by activated carbon adsorption, and includes an operation of deionizing for removing ions from the effluent liquids. The deionizing operation includes an apparatus having an electro dialysis stack of a plurality of ion exchange membranes and separating gaskets for selectively removing contaminant ions. The combination of treatment operations and the deionizing operation provides a continuous operating system with minimized down-time and improved efficiencies over prior methods for purification of liquid mixtures.

17 Claims, 6 Drawing Sheets

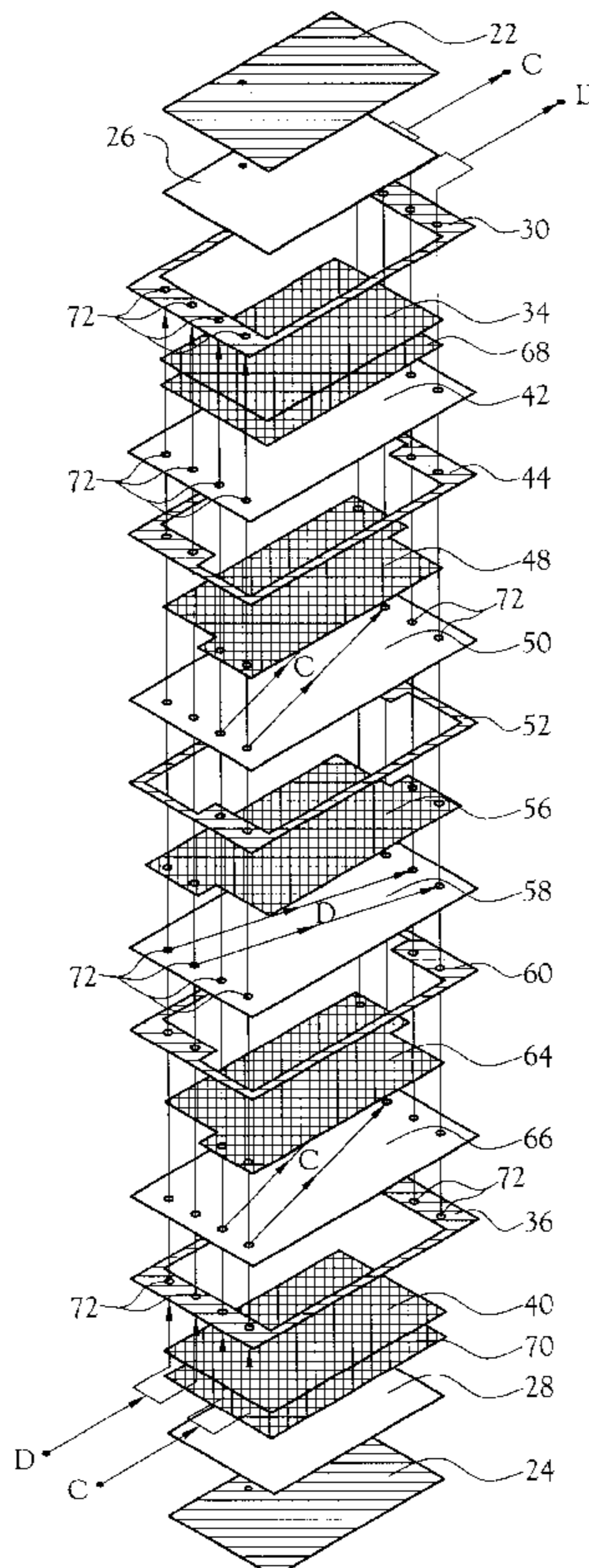

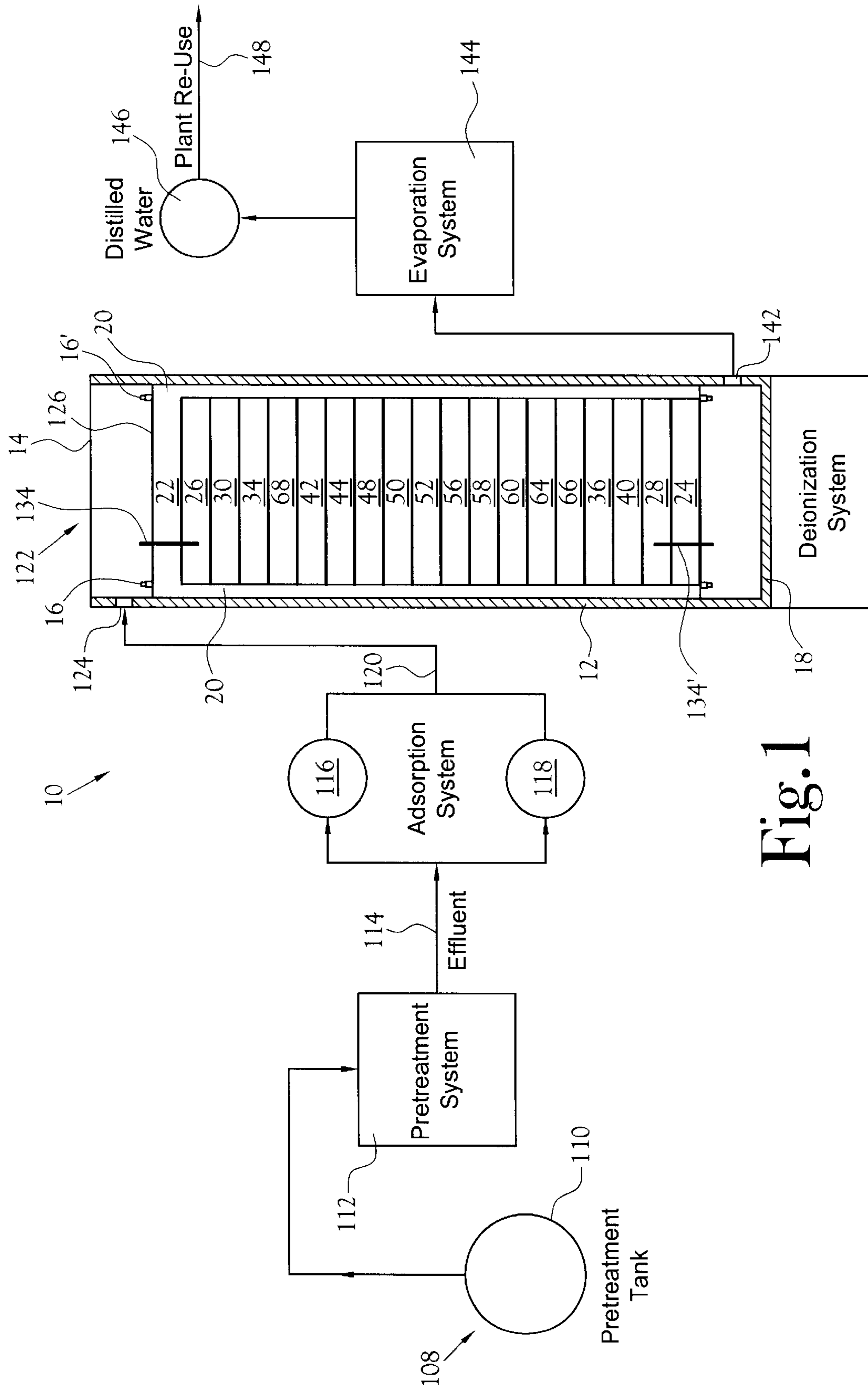

Fig. 1

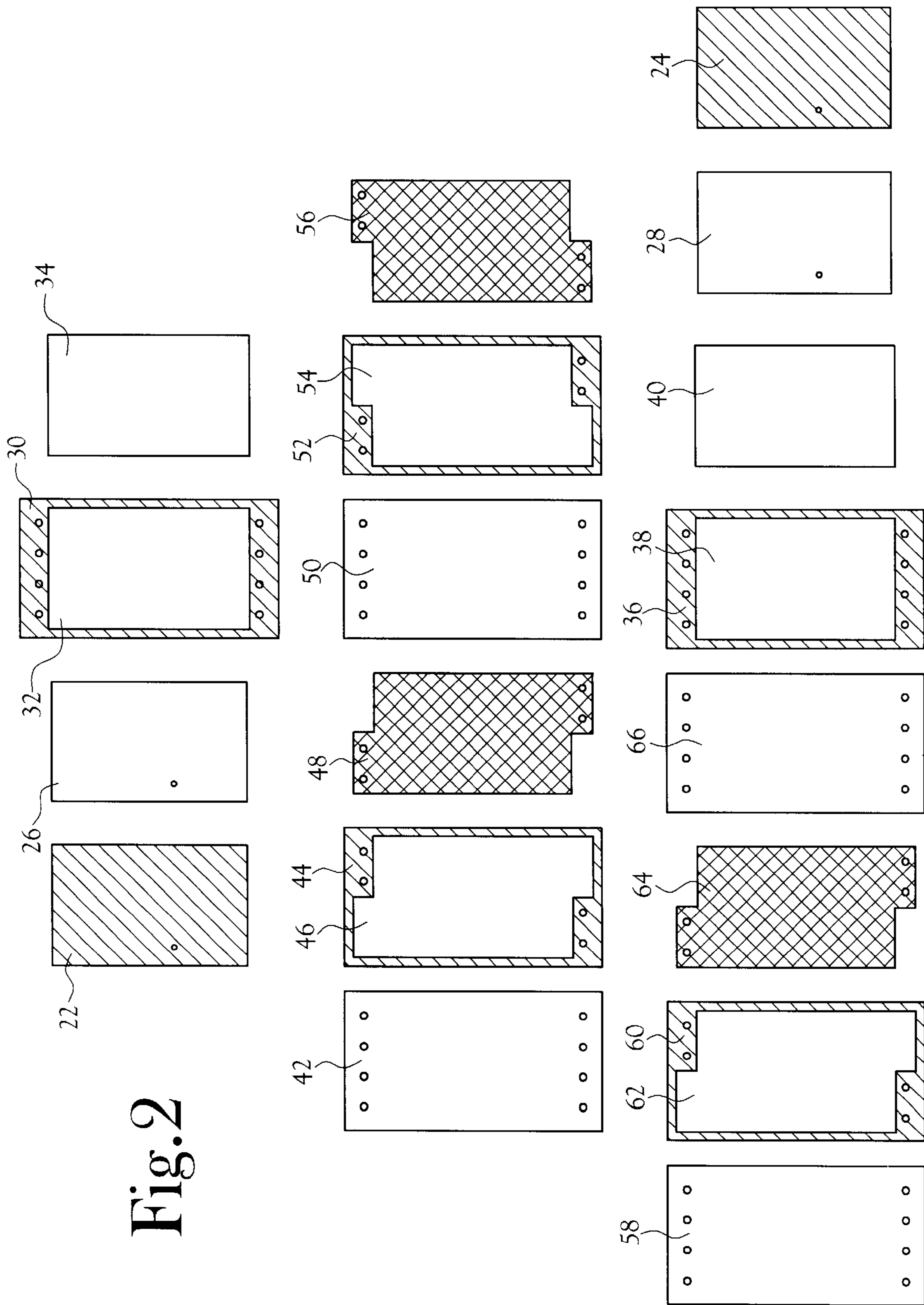

Fig. 2

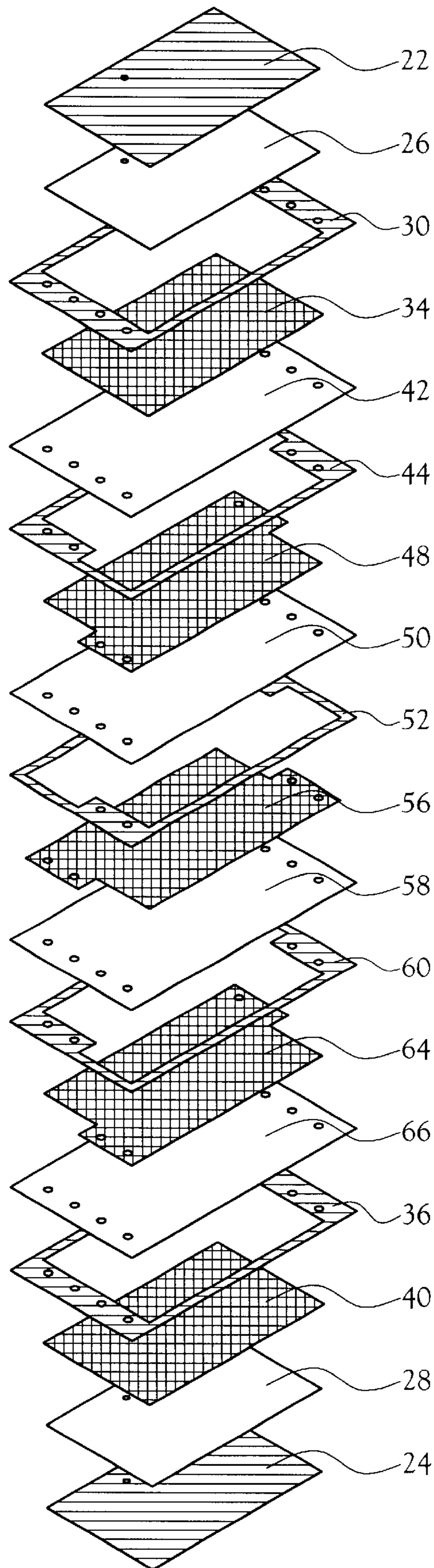

Fig. 3

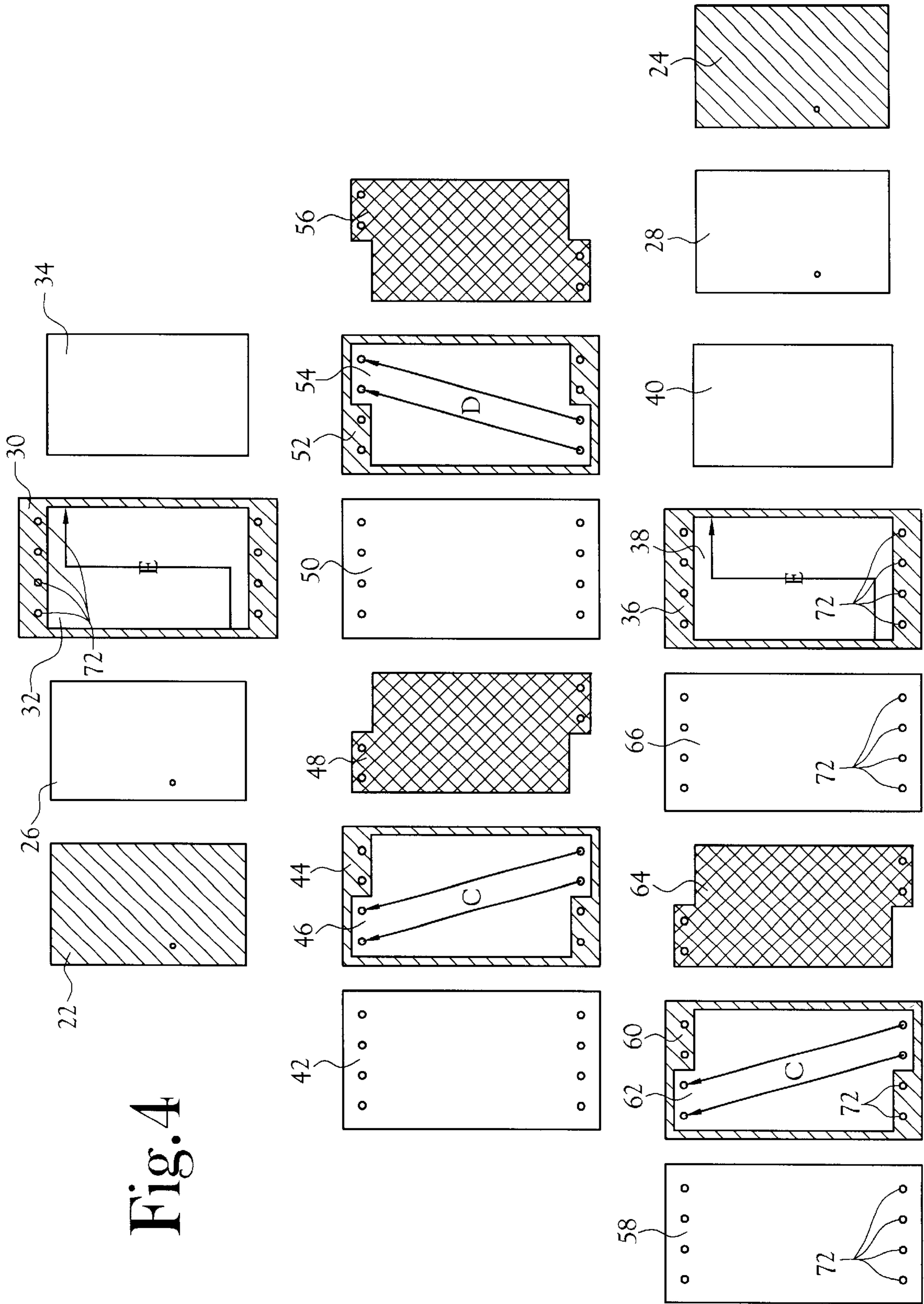

Fig. 4

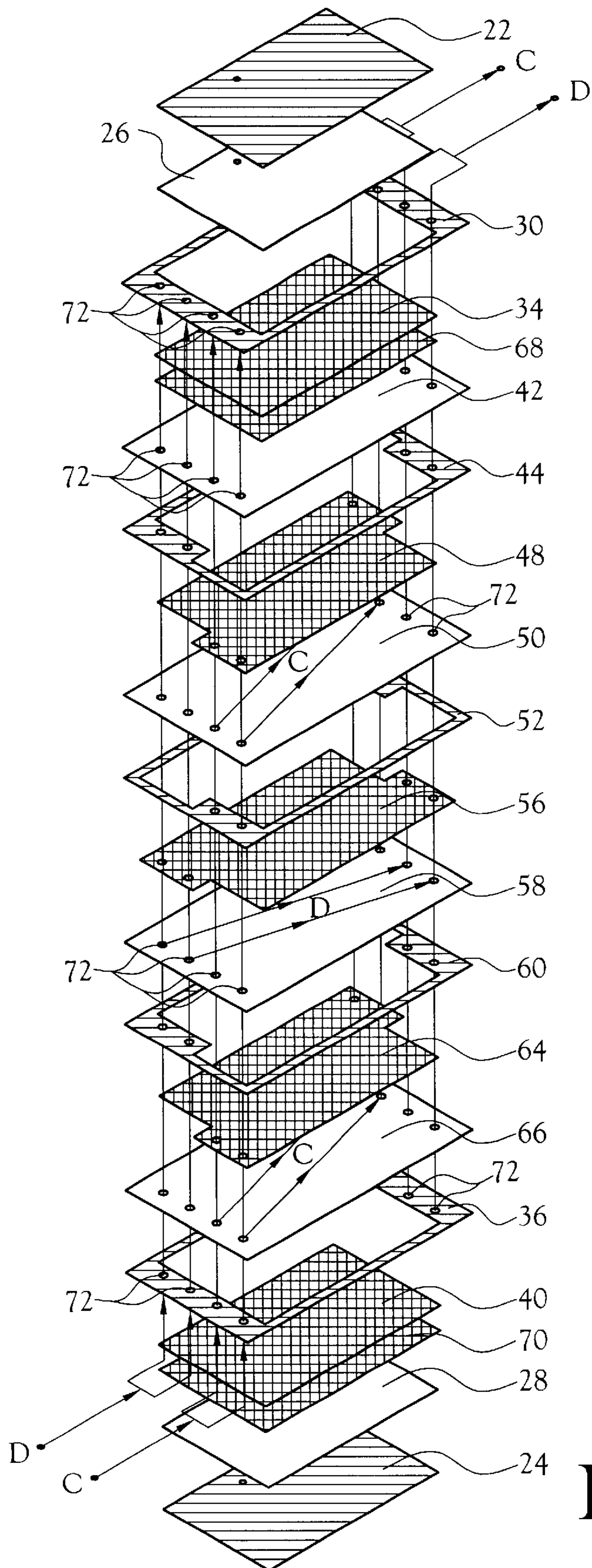

Fig.5

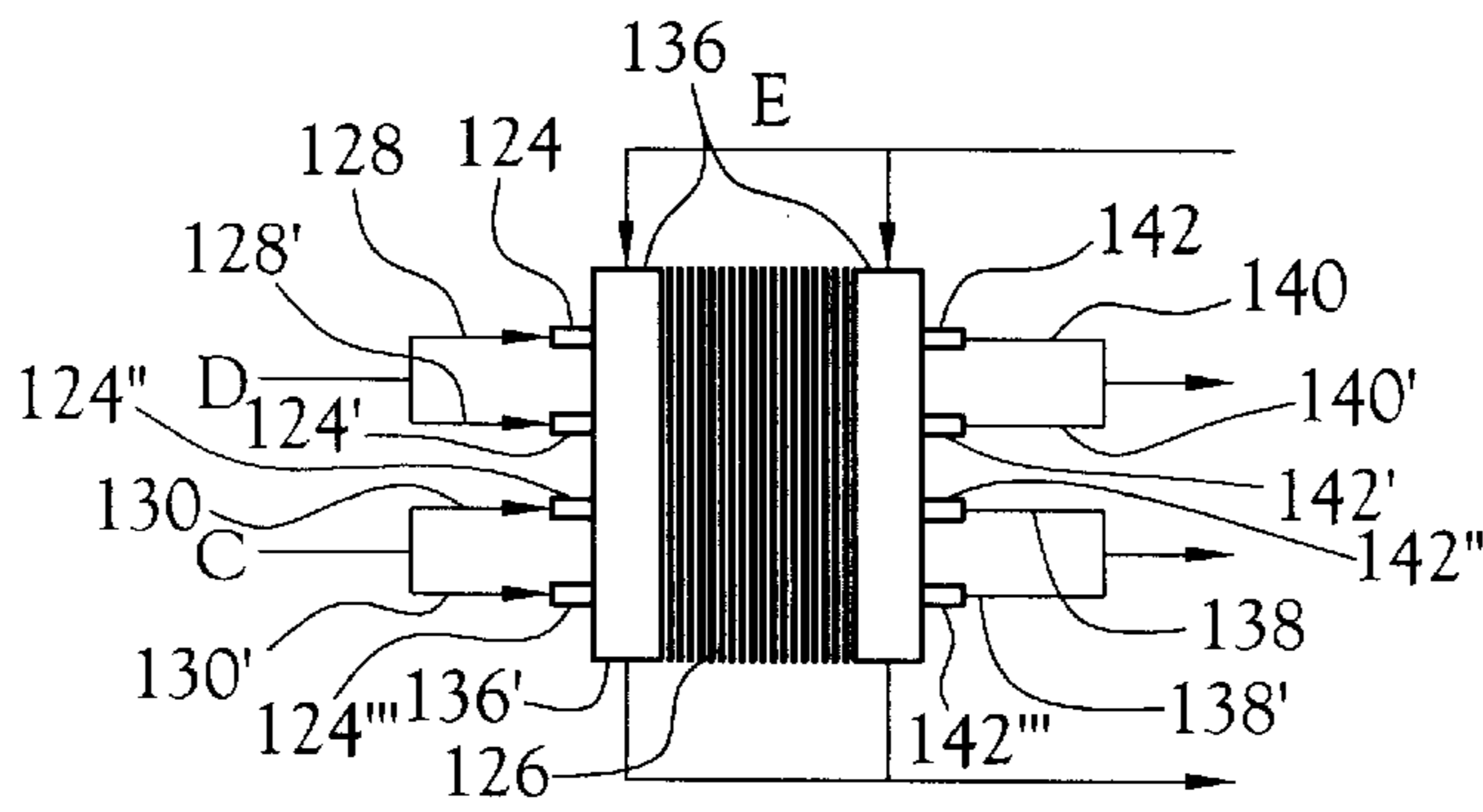

Fig. 6

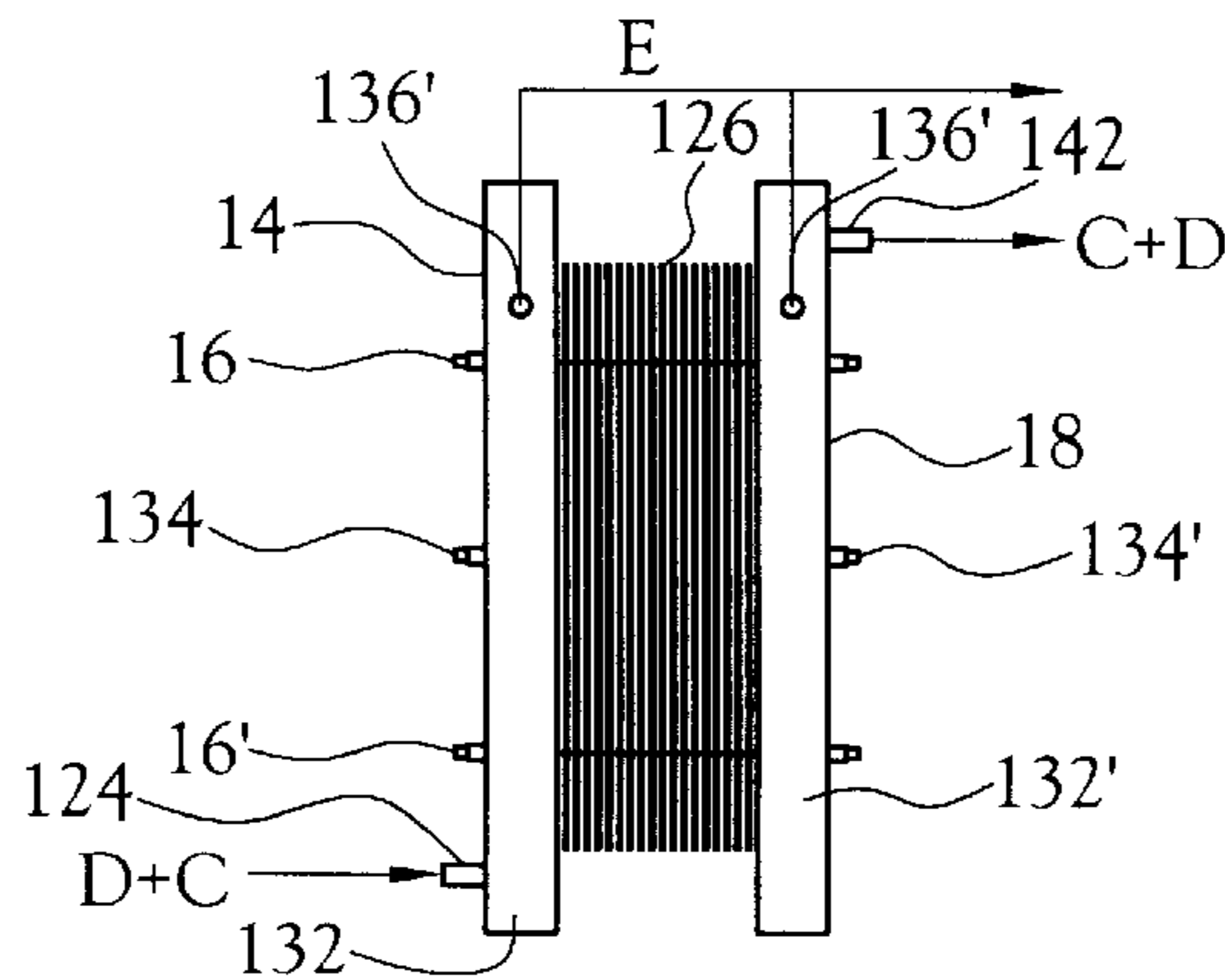

Fig. 7

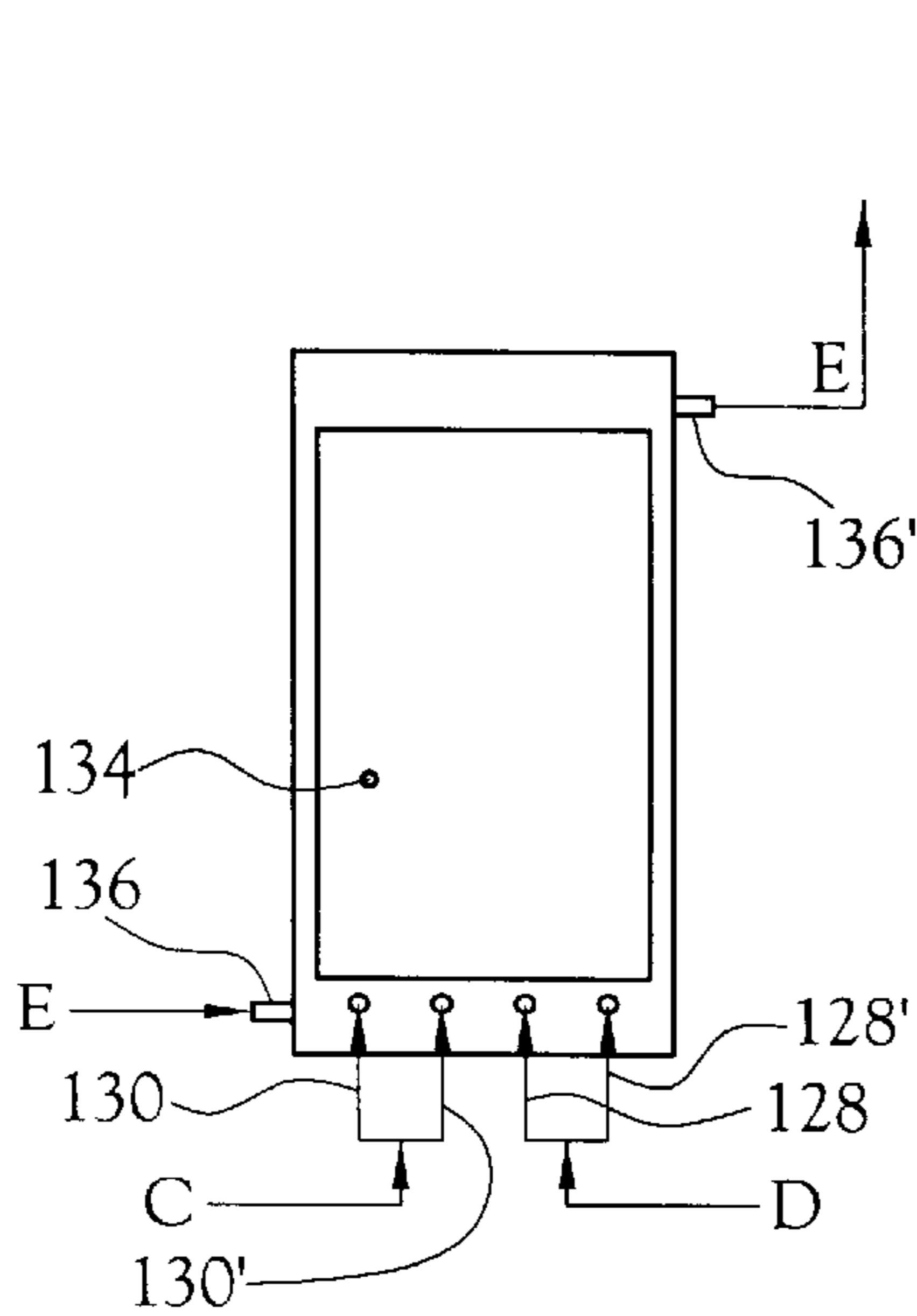

Fig. 8

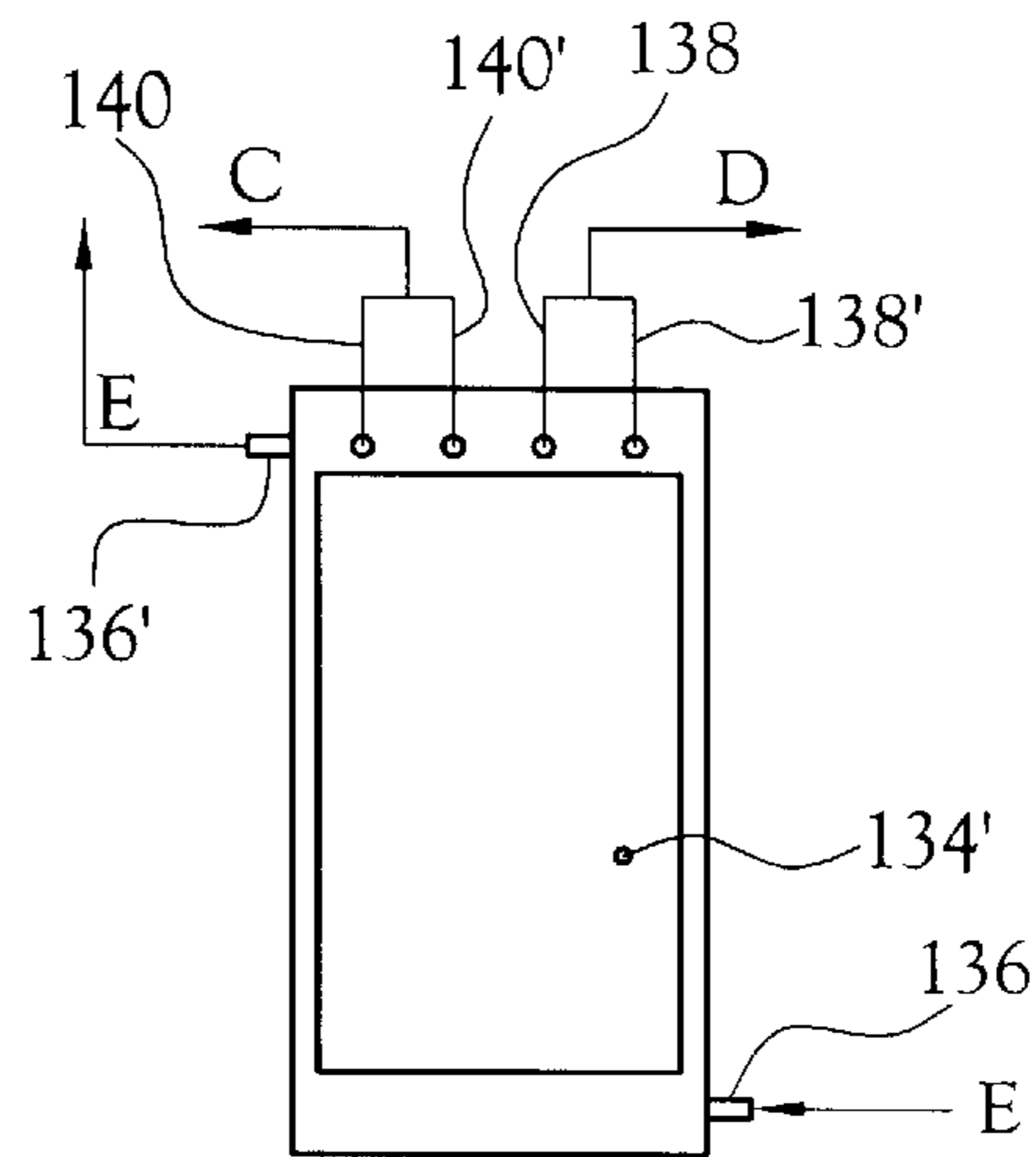

Fig. 9

ELECTRODIALYSIS MEMBRANE AND GASKET STACK SYSTEM

CROSS-REFERENCE TO RELATED APPLICATIONS

Not Applicable.

STATEMENT REGARDING FEDERALLY SPONSORED RESEARCH OR DEVELOPMENT

Not Applicable.

BACKGROUND OF INVENTION

1. Field of Invention

The invention relates to an apparatus and a system of operation of a plurality of ion-exchange membranes. More specifically, the invention relates to an apparatus and system of operation of a plurality of electro dialysis membranes and gaskets stacked for separation of components from liquids passing through the membranes.

2. Description of the Related Art

Prior methods of treatment for separating polar components in liquid mixtures having contaminants have been utilized to purify water, to desalinate water, and to purify ethylene glycol or other mixtures of chemicals. One method utilizes ion exchange resins for separation of polar components on granular ion exchange resins, which require chemical regeneration of the resins and/or disposal of the resins. Another treatment method for separating polar components in liquid mixtures include micro-porous membranes which selectively allow smaller polar compounds to pass through the membrane, while denying passage of larger sized polar compounds. Another treatment method includes ion exchange membranes having anion and cation exchange membranes assembled in an alternating configuration in a unit of membranes.

Prior purifying and recycling devices include a plurality of ion exchange bipolar membranes separating solution compartments, and gasket separators secured together in face-to-face contact in a configuration of a multi-layered, stacked plate. The gasket separators between the membranes provide sealing at the edges of the stacked plate of membranes, and enable a fluid to flow into and out of the stacked plate and through the individual solution compartments between the stacked plate of membranes. The ion exchange bipolar membranes can contain an anode and a cathode electrode at the respective ends of the stack of membranes in order to provide an electrical input for maintaining a differential voltage between the anode end and the cathode end. When a direct current is passed through the multi-layered stacked plate, the ions contained in the solution to be purified will migrate in a direction in relation to the current depending on the charge of each ion in the solution. The cations move toward the cathode or negative electrode, while the anions move toward the anode or positive electrode. By controlling the electrical input, and therefore the differential voltages, an operator induces the movement of the cations and anions in different directions across the stack of membranes, thereby operating the purifying and recycling system to remove contaminants from ethylene glycol, water, and/or other liquid solutions.

At least three types and sizes of stacks of electro dialysis membrane units are utilized in prior purifying and recycling devices, including an electro dialysis concentration cell having a cation membrane, a dilution or feed compartment, an anion membrane, and a concentrate or product compartment

which forms a unit utilized for desalinating of brine solutions. A second type of electro dialysis membrane unit includes a two-compartment cation cell having a bipolar membrane, a feed compartment, a cation membrane, and a base or product compartment. A third type of electro dialysis membrane unit includes a two-compartment anion cell having a bipolar membrane, a product compartment, an anion membrane, and a feed compartment. Additional types of electro dialysis membranes can include any combination of layers of the above three types to form a plurality of cation and anion membranes, interspersed with compartments and gaskets separating the compartments. Electro dialysis designs for flow through the stacks of electro dialysis membranes include sheet flow and tortuous flow. Sheet flow stacks induce liquid flow across the length or width of the active membrane surface area, and generally are utilized for low linear velocity conditions in the range of 5 to 10 cm/sec. Tortuous flow stacks induce liquids to take a long flow path around gaskets, and are utilized for higher linear flow velocity conditions in the range of 30 to 50 cm/sec.

Utilization of the electro dialysis designs as described above in stacks of membranes for purifying and recycling of ethylene glycol solutions, or for purifying water and desalinating water require a plurality of multiple membranes having complicated configurations. There is a need for a simplified design of a series of electro dialysis membranes in stacked configurations for improved removal efficiencies of contaminants in a purification and deionizing system.

Therefore, it is an object of the present invention to provide an improved membrane cell stack for purification of liquid mixtures.

It is another object of the present invention to provide a method of operation for an electro dialysis treatment system providing increased efficiency for ion-removal of liquid mixtures.

It is another object of the present invention to provide a membrane and gasket cell stack system having reduced assembly time.

It is another object of the present invention to provide a system having a plurality of membranes and interchangeable gaskets for improved efficiency for removal of contaminants by electro dialysis deionizing of liquid mixtures.

It is another object of the present invention to provide an improved system having a plurality of membranes and interchangeable gaskets for improved efficiency for deionizing liquid mixtures by an electro dialysis apparatus.

BRIEF SUMMARY OF INVENTION

An apparatus and system of operation is disclosed for the separation of polar components, inorganic contaminants, and organic contaminants within liquid mixtures. The apparatus and system of operation for purification and deionizing liquid mixtures includes an operation of pretreatment by utilizing filtration for removal of inorganic contaminants and organic contaminants utilizing oil/water separation methods and settling methods for removal of suspended solids. The system of operation includes an operation of adsorption treatment for the filtrate effluent of the pretreatment operation. The adsorption operation includes removing organic contaminants by utilizing activated carbon adsorption methods.

The system of operation further includes an operation of deionizing for treating of the effluent liquids from the adsorption operation. The deionizing operation includes a system utilizing an apparatus having an electro dialysis cell stack including a plurality of disparate layers being stacked

together, the electro dialysis cell stack having a first end and a second end, with the plurality of disparate layers stacked contiguous between the first end and second end. A support frame supports the cell stack and encloses a perimeter of the plurality of disparate layers, with the layers being disposed in a repetitive sequence of layers between the first outer end and second outer end of the support frame. The plurality of disparate layers of materials are disposed contiguous, having a first outer layer at the first end, and a second outer layer at the second end, with the plurality of disparate layers inter-disposed therebetween. The plurality of disparate layers include at least two electro dialysis membranes, the first of the electro dialysis gaskets being positioned as the first outer layer at the first end, opposite the second of the electro dialysis gaskets being positioned as the second outer layer at the second end.

A cathode electrode plate is positioned proximate to the first end and interior of the first electro dialysis gasket. An anode electrode plate is positioned proximate to the second end and interior of the second electro dialysis gasket at the second end. A voltage generating means is connected to the cell stack for application of an electrical voltage differential between the cathode electrode plate and the anode electrode plate

The plurality of disparate layers are disposed between the cathode and anode electrode plates and include a series of layers of differing permeability, the layers selected from a group comprising a first electro dialysis membrane gasket, a first turbulence promoter, an anion membrane, a second electro dialysis membrane gasket, a second turbulence promoter, a cation membrane, a third electro dialysis membrane gasket, and a third turbulence promoter, whereby the plurality of disparate layers can be repeated in series as required. A connecting means provides connection of the plurality of disparate layers within the support frame, the connecting means including removably attachable connectors to allow the plurality of disparate layers to be replaced, and/or additional series of layers of differing permeability to be added to the electro dialysis cell stack.

The electro dialysis cell stack can further include the series of layers being repeated as required for removal of polar components and/or additional contaminants, with additional turbulence promoters being added to increase the dispersion of the liquid mixtures therethrough to increase the efficiency of removal of contaminants upon application of electrical voltage differential between the cathode electrode plate and the anode electrode plate.

The electro dialysis cell stack of disparate layers and enclosing frame of the deionizing operation provides continuous purifying of ethylene glycol and glycol/water mixtures, provides for continuous desalinating of water, and/or provides for continuous deionizing of water to generate ultra-pure water or other purified liquid mixtures.

The deionizing operation can be followed by an evaporation system for removal of excess water from the purified ethylene glycol or other liquid mixtures, with the purified liquids and/or deionized liquids being available for recycle and reuse. The combination of treatment operations and the deionizing operation provides a continuous operating system with minimized down-time and improved efficiencies over prior methods for purification and deionizing liquid mixtures.

BRIEF DESCRIPTION OF THE DRAWINGS

The above-mentioned objects and advantages of the present invention are readily apparent from the description

of the invention contained herein, and by reference to the claims, read together with the drawings, in which:

FIG. 1 is a flow diagram illustrating the operations of the present invention for purification and deionizing liquid mixtures utilizing an electro dialysis operation;

FIG. 2 is a process schematic of one embodiment of a plurality of disparate layers of an electro dialysis cell stack of ion exchange membranes of the deionizing operation of FIG. 1;

FIG. 3 is a perspective view of a plurality of disparate layers of the electro dialysis cell stack of FIG. 2;

FIG. 4 is a process schematic of FIG. 2 of a plurality of disparate layers illustrating the flow of liquid mixtures through and across the disparate layers;

FIG. 5 is a perspective view of FIG. 3 of a plurality of disparate layers illustrating the flow of liquid mixtures through the stacked disparate layers;

FIG. 6 is a top view of an assembled plurality of disparate layers of the electro dialysis cell stack of FIG. 2;

FIG. 7 is a side view of the assembled electro dialysis cell stack of FIG. 6;

FIG. 8 is a front view of the assembled electro dialysis cell stack of FIG. 7; and

FIG. 9 is a rear view of the assembled electro dialysis cell stack of FIG. 8.

DETAILED DESCRIPTION OF THE INVENTION

In accordance with the present invention, there is disclosed an apparatus and system of operation for the separation of polar components, inorganic contaminants, and organic contaminants within liquid mixtures for purification and deionizing liquid mixtures. FIG. 1 illustrates the plurality of operations **10** for adequate operation of one embodiment of the deionizing system **122** of the present invention of the apparatus and system of operation, including an operation of pretreatment for a volume of contaminated liquids **108** by utilizing filtration for removal of inorganic contaminants and organic contaminants removal utilizing oil/water separation of suspended solids in a plurality of storage tanks **110**. The pretreatment operation **112** utilizes an oil/water separator **112** and storage containers known to those skilled in the art.

The system of operation includes an operation of adsorption **116, 118** for treating of the effluent liquids **114** from the pretreatment operation. The adsorption operation includes removing organic contaminants by utilizing activated carbon adsorption compounds known to those skilled in the art.

The system of operation further includes an operation of deionizing **122** for treating of the effluent liquids **120** from the adsorption operation. The deionizing operation includes an apparatus including an electro dialysis membrane cell stack **12** having a plurality of ion exchange membranes and separating gaskets for selectively removing contaminant ions from the effluent liquids. The membrane cell stack **12** includes a first end **14**, a central stack of a plurality of disparate layers being stacked on top of each layer (see FIG. 1), or being stacked side-by-side (see FIG. 6), and a second end **18** opposed from the first end **14** and enclosing the plurality of disparate layers.

A support frame **20** utilizing connecting members such as a pair of connector bolts **16, 16'** through the perimeter of the central stack provides a partially enclosing frame for the plurality of disparate layers that are disposed contiguous within the support frame **20**. The support frame **20** includes

a first end proximate the first end **14** of the central stack, and a second end proximate the second end **18** of the central stack.

The plurality of disparate layers of materials are disposed contiguous, having a first outer layer at the first end **14**, and a second outer layer at the second end **18**, with the plurality of disparate layers interdisposed therebetween (see FIG. 2 and 3). The plurality of disparate layers include at least two electro dialysis gaskets composed of ethylene propylene diene monomer (EPDM), the first EPDM gasket **22** being positioned as the first outer layer proximate the first end **14**, with a second EPDM gasket **24** being positioned as the second outer layer proximate the second end **18**.

The first electro dialysis EPDM gasket **22** and the second electro dialysis EPDM gasket **24** are each about 0.031 inches thick, and have the following dimensions. Each gasket **22**, **24** includes an exterior width of about 1'5³/₈" , and an exterior length of about 2'3⁷/₈" , with a ³/₄" diameter off-center hole through an area about 2¹¹/₁₆" distance inward to the center of the off-center hole from a first side of the gaskets **22**, **24**, and the center of the off-center hole about 1'5⁷/₁₆" along the length from the top edge of the gaskets **22**, **24**.

A cathode electrode plate **26** is positioned proximate the first end **14** of the plurality of disparate layers. The cathode electrode plate **26** can be composed of a stainless steel plate and is positioned within the first electro dialysis gasket **22**. An anode electrode plate **28** is positioned proximate the second end **18**, can be composed of a titanium and platinum alloy, and is positioned inwardly within the second electro dialysis gasket **24**. The cathode electrode plate **26** and the anode electrode plate **28** are about 0.030 inches thick, and have the following dimensions. The plates **26**, **28** have an exterior width of about 1'5³/₈" , and an exterior length of about 2'3⁷/₈" , with an off-center ³/₈" threaded rod through an area of about 2¹¹/₁₆" distance inward to the center of the off-center rod from a first side of the plates **26**, **28**, and the center of the off-center rod about 1'5⁷/₁₆" along the length from the top edge of the plates **26**, **28**. Connector rods **16**, **16'** of about four inches in length are utilized to connect the plates **26**, **28** and a plurality of layers between together. A voltage generating means (not shown) is connectable to the cathode electrode plate **26** and separately to the anode electrode plate **28** of the membrane cell stack **12** for application of an electrical voltage differential between the cathode electrode plate **26** and the anode electrode plate **28**. The voltage generating means can include a voltage generator and an electrode **134** inserted to contact the cathode electrode plate **26**, and a separate electrode **134'** inserted to contact the anode electrode plate **28**. The application of an electrical voltage differential provides for improved removal of polar contaminants from concentrated liquids directed across the cation membranes **50**, **66** (discussed below) that are located between the cathode electrode plate **26** and the anode electrode plate **28**.

The third layer positioned inwardly from the first end **14** is an outer electro dialysis EPDM gasket **30** positioned next to the cathode electrode plate **26**, with another outer electro dialysis EPDM gasket **36** positioned next to the anode electrode plate **28** near the second end **18**. The outer electro dialysis EPDM gaskets **30**, **36** are about 0.062 inches thick (**70** Duro), and have the following dimensions. The EPDM gaskets **30**, **36** include an exterior width of about 1'8" , and an exterior length of about 3'1" , with about four spaced apart end holes of about 1" diameter through an area in the upper portion of each gasket **30**, **36**, with each end hole center being about 2³/₄" down from the upper edge of the gaskets **30**, **36**. The interiors **32**, **38** of the respective

gasket gaskets **30**, **36** are open to allow for optional placement of a layer of an appropriately sized turbulence promoter **34**, **40** against the gaskets **30**, **36**. Each interior **32**, **38** includes inside dimensions of a width of about 1'5¹/₂" , and a length of about 2'4³/₄" . Each turbulence promoter **34**, **40** is sized with a width of about 1'5³/₈" , and a length of about 2'4³/₈" . The turbulence promoters **34**, **40**, if utilized in the membrane cell stack **12**, are composed of a polypropylene fabric of about 0.030 inches thick. The turbulence promoters **34**, **40** can be combined with additional back-to-back stacked turbulence promoters **68**, **70** (see FIG. 5) to create additional turbulence in liquids moving through and past the respective gasket gaskets **30**, **36**.

The fourth layer inwards from the first end **14** (without counting the plurality of turbulence promoters **34**, **68**, **40**, **70** that may be added), includes an anion membrane **42**. The anion membrane **42** is the first of approximately six layers of a series of layers that can be repeated as often as desired by the operators of the electro dialysis system **10** for improved efficiency and flow of liquids through the membrane cell stack **12**. The anion membrane **42** is about 0.031 inches thick, and includes the dimensions of about 1'8" wide and about 3'1" long with four spaced apart end holes of about 1" diameter through an area in the upper portion of the anion membrane **42** with each end hole center being about 2³/₄" down from the upper edge of the anion membrane **42**.

Additional membranes, EPDM gaskets, and plate layers of the series of layers can include a fifth layer (without counting the plurality of turbulence promoters **34**, **68**, **40**, **70** that may be added), composed of an electro dialysis EPDM gasket **44** having an offset interior opening **46**. The EPDM gasket **44** is about 0.031 inches thick (**60** Duro), and the dimensions of an exterior width of about 1'8" , and an interior opening width of about 1'5¹/₂" . The interior opening **46** includes an upper interior corner opening offset from the upper exterior side of the first or right side of about 8³/₄" , and is offset downwards of about 3" from the upper exterior side of gasket **44**. A similar sized offset in the interior opening **46** is within the opposed lower interior corner and includes an offset from the exterior side of the second or left side of about 8³/₄" , and is offset upward about 3" from the lower exterior side of gasket **44** (see FIGS. 2-5).

A sixth layer (without counting the plurality of turbulence promoters **34**, **68**, **40**, **70** that may be added) is composed of a turbulence promoter **48** having an offset shape having an appropriate size for insertion into the interior opening **46** of EPDM gasket **44**. The outer dimensions of promoter **48** includes a width of about 1'5³/₈" , and a length of about 2'10³/₈" , with offset extensions sized appropriately to be insertable into the interior opening **46** of EPDM gasket **44**.

A seventh layer (without counting the plurality of turbulence promoters **34**, **68**, **40**, **70** that may be added) is composed of a cation membrane **50** having a generally rectangular size of a width of about 1'8" , and a length of about 3'1" . The cation membrane **50** includes four spaced apart end holes of about 1" diameter through an area in the upper portion of the cation membrane **50** with each end hole center being about 2³/₄" down from the upper edge of the cation membrane **50**, and four spaced apart end holes of about 1" diameter through an area in the lower portion of the cation membrane **50** with each end hole center being about 2³/₄" up from the lower edge of the membrane **50**.

An eighth layer (without counting the plurality of turbulence promoters **34**, **68**, **40**, **70** that may be added) is composed of another electro dialysis EPDM gasket **52** having an offset interior opening **54**. The EPDM gasket **52**

includes generally the dimensions of EPDM gasket **44**, with the interior offset dimensions of the upper and lower opposed corners of opening **54** being a mirror image of interior opening **46**.

A ninth layer (without counting the plurality of turbulence promoters **34**, **68**, **40**, **70** that may be added) is composed of another turbulence promoter **56** having an offset shape for insertion into the interior opening **54** of EPDM gasket **52**.

The plurality of disparate layers, fourth through ninth layers, can be repeated after EPDM gasket **52** and/or turbulence promoter **56**, as required to improve efficiency of removal of polar components. A repeat set of disparate layers, can include anion membrane **42**, EPDM gasket **44** having opening **46**, and turbulence promoter **48** being sized for insertion into opening **46**. Cation membrane **50** is followed by EPDM gasket **52** having opening **54**, and turbulence promoter **56** being sized for insertion into opening **54**.

Following one or more sets of disparate layers **42-52**, another anion membrane **58** is positioned, the anion membrane **58** having the dimensions of anion membrane **42** described above. The anion membrane **58** is followed by EPDM gasket **60** having opening **62** sized and shaped comparable to EPDM gasket **44** and opening **46**. Turbulence promoter **64** is sized and shaped to fit closely against EPDM gasket **60**, with a cation membrane **66** following in series. Cation membrane **66** is sized and shaped comparable to cation membrane **50**.

The second end layers include the layers discussed above of second electro dialysis EPDM gasket **36**, having opening **38** therethrough, followed by turbulence promoter **40**, or additional stacked turbulence promoters, followed by the outer second end layers of anode electrode plate **28**, and the second electro dialysis EPDM gasket **24**. Concentrate C liquid streams and dilute D liquid streams are directed through the cell stack **12** by passage through a plurality of end holes **72** in each of the following layers: **30**, **42**, **44**, **48**, **50**, **52**, **56**, **58**, **60**, **64**, **66**, and **36**. Concentrate C liquid streams and dilute D liquid streams can be directed into the cell stack **12** at the first end **14**, as shown in FIG. **1**, for passage through the plurality of end holes **72**, and exiting at the second end **18**, or alternatively can be directed into the end proximate the anode plate **28**, as shown in FIG. **5**, for passage through the plurality of end holes **72**, and exiting at the end proximate cathode plate **26**.

A connecting means such as a support frame **20** known to those skilled in the art is connected by connection rods **16**, **16'** through the outer edges of the layers including EPDM gasket **30**, the EPDM gasket **36**, for containment of the membrane cell stack **12** positioned within the support frame **20**.

A method of operation is disclosed including a system for electro dialysis treatment of contaminated liquid mixtures including the operations of feeding a volume of contaminated liquids **108**, into a pretreating system **112** for filtration of inorganic contaminants and organic contaminants with the pretreatment operation including a pretreatment settling tank **110**. The pretreatment system **112** can incorporate an oil-water separator known to those skilled in the art, for generating a filtrate effluent **114** that is processed by an adsorbing operation **116**, **118** for adsorbing organic contaminants from the filtrate effluent utilizing activated carbon adsorption **116**, and/or polishing with carbon particles in a polishing step **118**, with the adsorbing operation **116**, **118** generating a liquid fraction **120** for transfer to electro dialysis deionizing operation **122**.

A preferred embodiment for the method of the deionizing operation **122** is illustrated in FIGS. **4-9**. The electro dialysis membrane cell stack **126** includes a plurality of disparate layers enclosed within a support frame **20** supported by end plates **132**, **132'**. The end plates **132**, **132'** can be composed of generally rigid PVC materials. Connector members such as a pair of connector bolts **16**, **16'** of about $\frac{7}{8}$ inch threaded diameter and having lengths of about four inches long fasten the cell stack **126** together.

Multiple input streams are introduced through end plate **132**, into input valves **124**, **124'**, **124''**, **124'''**, with multiple output streams released from end plate **132'**, from output or exit valves **142**, **142'**, **142''**, **142'''** (see FIGS. **6-9**). The liquid streams requiring deionizing are directed through the cell stack **126** by passage through a plurality of end holes **72** in each of the following respective layers: **30**, **42**, **44**, **48**, **50**, **52**, **56**, **58**, **60**, **64**, **66**, and **36**.

The cell stack **126** (see FIGS. **4-7**) can accept multiple input streams such as dilute D input streams **128**, **128'**, and concentrate C input streams **130**, **130'**. The concentrate C input streams **130**, **130'** are directed through the plurality of end holes **72** of the respective layers of cell stack **126**, and the streams **130**, **130'** travel between cation membranes **50**, **66** and anion membranes **42**, **58** due to the influence of turbulence promoters **48** and **64**, and EPDM gaskets **44**, **52**, **36** and **60**, to follow a tortuous flow for exit as concentrate C exit streams **140**, **140'** from the cell stack **126** at exit valves **142**, **142'**.

The dilute D input streams **128**, **128'** are directed through the cell stack **126** through the plurality of end holes **72** forming an outer passage at each opposed end of a plurality of the layers of the cell stack to follow a tortuous flowpath at about the middle portions of the cell stack **126**, due to the influence of turbulence promoter **56** and EPDM gaskets **52** and **60**. The dilute D streams pass through the outer passage holes of stacked membranes and gaskets for exit of the dilute D exit streams **138**, **138'** from the cell stack **126** at exit valves **142''** and **142'''** (see FIGS. **4** and **5**).

Electrode **134** is inserted through front end plate **132**, and extends through EPDM gasket **22**, for contact with, and maintenance of an electrical charge on cathode plate **26**. Electrode **134'** is inserted through rear end plate **132'**, and extends through EPDM gasket **24**, for contact with, and maintenance of an electrical charge on anode plate **28**. The electrodes are about $\frac{3}{8}$ inch diameter threaded rods.

As shown in FIGS. **4**, **6-9**, an electrolyte E stream is injected in one side into at least one intake valve **136** of front end plate **132**, for flow across the cathode plate **26** near the first end **14**, and flow across the anode plate **28** near the second end **18**, for exit from at least one exit valve **136'** in the back end plate **132'** of the cell stack **126** without mixing with the dilute D streams or the concentrate C streams. The electrolyte E stream can be composed of a salt solution that provides a conducting solution to each cathode plate **26** and anode plate **28** of the cell stack **126** for improved performance of each electrically charged plate **26**, **28**.

The electro dialysis deionizing operation **122** selectively removes contaminant ions from the liquid fraction during the continuous passage of the liquid fraction through the cell stack **126**. The electro dialysis cell stack of the deionizing operation provides continuous purifying for ethylene glycol or for glycol/water mixtures, for continuous desalinating of water, and/or for continuous deionizing of water to generate ultra-pure water or other purified liquid mixtures.

The deionizing operation can be followed by an evaporation system **144** for removal of excess water from the

purified ethylene glycol or other liquid mixtures, with the purified liquids and/or deionized liquids being available for combining with distilled water in a dilution process 146, for recycle and reuse of the purified and deionized liquid effluent 148.

The combination of treatment operations and the deionization operation provides a continuous operating system with minimized down-time and improved efficiencies over prior methods for purification and deionizing of liquid mixtures.

Analytical results demonstrate the efficiency of the deionizing operation utilizing the electro dialysis stack having a plurality of ion exchange membranes and separating gaskets as illustrated in FIGS. 2 and 3. The analytical results were obtained by testing of the electro dialysis membrane stack design utilizing four cells in parallel, versus a baseline design of cells without the improved electro dialysis membrane cell stack 126 design. The percent reduction in processing time is based on average overall deionizing time, and based on average conductivity change per time per unit of four cells. The results can be summarized that four cells with the improved membranes instead of four cells having prior art membrane stack designs, plus operating in parallel the improved electro dialysis membrane cell stack 12 design provides about 42% to about 44% decrease in processing time for a 5,000 gallon batch of liquids compared to prior membrane stack designs. The average processing time for a 5,000 gallon batch of liquids is estimated to be about 20.5 hours per batch, reduced from an average of about 36.9 hours per batch for prior art membrane stack designs.

The benefits of the apparatus and system of operation disclosed is a reduction in overall processing times for the separation of polar components within liquid mixtures for purification and deionization of liquid mixtures, an ease of assembly for reduction in assembly times, and a simplified assembly with a lesser amount of parts.

One skilled in the art will recognize the associated mechanical components which support the system are illustrated in the Figures for clarity only and other embodiments could be utilized without interfering with the objects and advantages of the present invention.

While a preferred embodiment is shown and described, it will be understood that it is not intended to limit the disclosure, but rather it is intended to cover all modifications and alternative apparatus configurations and systems of operation falling within the spirit and the scope of the invention as defined in the appended claims.

What is claimed is:

1. A membrane cell stack for purification of liquid mixtures having contaminants dispersed therein, and for deionization of liquid mixtures by passage through the membrane cell stack, the liquid mixtures including concentrate liquids and/or dilute liquids, said membrane cell stack comprising:

an electro dialysis cell stack including a plurality of disparate layers being stacked together, said electro dialysis cell stack having a first end and a second end, said plurality of disparate layers being disposed contiguous and having a first outer layer at said first end, and a second outer layer at said second end;

a support frame having a first outer end proximate said first end of said cell stack, and having a second outer end proximate said second end, with said plurality of disparate layers interdisposed therebetween said first outer end and said second outer end;

at least two electro dialysis gaskets including a first electro dialysis gasket being positioned at said first outer

end, and a second electro dialysis gasket being positioned at said second outer end;

a cathode electrode plate being positioned proximate and interior of said first electro dialysis gasket being positioned at said first outer end;

at least one anode electrode plate being positioned proximate and interior of said second electro dialysis gasket being positioned at said second outer layer;

at least two membrane gaskets including a first membrane gasket being positioned proximate and interior of said cathode electrode plate, and a second membrane gasket being positioned proximate and interior of said anode electrode plate, said first membrane gasket and said second membrane gasket having a central opening therethrough and having a plurality of holes through each opposed end for passage of liquid mixtures therethrough;

said plurality of disparate layers including:

an anion membrane having a plurality of holes through each opposed end for passage of liquid mixtures therethrough;

at least one electro dialysis membrane gasket having a central opening therethrough and having a plurality of holes through each opposed end for passage of liquid mixtures therethrough;

at least one turbulence promoter layer being sized to fit proximate said opening within said at least one electro dialysis membrane gasket and having a plurality of holes through each opposed end for passage of liquid mixtures therethrough; and

a cation membrane having a plurality of holes through each opposed end for passage of liquid mixtures therethrough;

whereby said plurality of disparate layers being repeated in series, the liquid mixtures being passed through said plurality of holes in respective disparate layers of said electro dialysis cell stack; and

connecting means for connection of said plurality of disparate layers within said support frame;

whereby said electro dialysis cell stack including said plurality of disparate layers being repeated as required for purification and deionization of the liquid mixtures being passed therethrough.

2. The membrane cell stack of claim 1, wherein said electro dialysis cell stack further comprises a voltage generating means for application of an electrical voltage differential between said cathode electrode plate and said at least one anode electrode plate, said voltage generating means including a voltage generator, said electro dialysis cell stack having a first electrode in contact with said cathode electrode plate, and a second electrode in contact with said at least one anode electrode plate.

3. The membrane cell stack of claim 1, wherein said plurality of disparate layers being stacked adjacent and having a plurality of shapes being sized for being positioned within said support frame, said plurality of disparate layers further includes a plurality of turbulence promoter plates and a plurality of electro dialysis membrane gaskets being positioned between said anion membrane and said cation membrane for direction of the waste liquids from the plurality of holes through each opposed end of each disparate layer to the plurality of holes through each adjacent disparate layer for passage of liquid mixtures therethrough said electro dialysis cell stack.

4. The membrane cell stack of claim 1, wherein said first electro dialysis gasket and said second electro dialysis gasket

being composed of ethylene propylene diene monomer of about 0.031 inch thickness.

5. The membrane cell stack of claim 1, wherein said first membrane gasket and said second membrane gasket being composed of ethylene propylene diene monomer of about 0.062 inch thickness.

6. The membrane cell stack of claim 1, wherein said at least one turbulence promoter being composed of polypropylene fabric of about 0.030 inch thickness.

7. The membrane cell stack of claim 1, wherein said at least one electro dialysis membrane gasket having an opening therethrough being composed of ethylene propylene diene monomer of about 0.031 inch thickness.

8. The membrane cell stack of claim 1, wherein said first end of said electro dialysis cell stack comprising a first input valve and a second input valve through said first end for receipt of concentrate liquids in said first input valve, and for receipt of dilute liquids in said second input valve, whereby said concentrate liquids and said dilute liquids being passed through said plurality of disparate layers of said electro dialysis cell stack.

9. The membrane cell stack of claim 8, wherein said second end of said electro dialysis cell stack comprising a first output valve and a second output valve through said second end for passage of concentrate liquids out of said second output valve, and for passage of dilute liquids out of said first output valve, whereby said concentrate liquids and said dilute liquids having passed through said plurality of disparate layers of said electro dialysis cell stack.

10. The membrane cell stack of claim 9, wherein said support frame having a first outer end and having a second outer end, further comprises:

at least one intake valve in said first outer end;

an electrolyte liquid being input into said at least one intake valve, said electrolyte liquid being in contact across said cathode electrode plate;

said electrolyte liquid being in contact across said anode electrode plate; and

at least one exit valve in said second outer end for removal of said electrolyte liquid from said cell stack;

whereby said electrolyte liquid does not contact said concentrate liquids or said dilute liquids within said cell stack.

11. A membrane cell stack for purification of liquid mixtures having contaminants dispersed therein in concentrate liquids and/or in dilute liquids, and for deionization of liquid mixtures by passage through said membrane cell stack comprising:

an electro dialysis cell stack including a plurality of disparate layers being stacked together, said electro dialysis cell stack having a first end and a second end, said plurality of disparate layers being disposed contiguous and having a first outer layer at said first end, and a second outer layer at said second end;

a support frame having a first outer end proximate said first end of said cell stack, and having a second outer end proximate said second end, with said plurality of disparate layers interdisposed therebetween said first outer end and said second outer end;

at least two electro dialysis gaskets including a first electro dialysis gasket being positioned at said first outer end, and a second electro dialysis gasket being positioned at said second outer end;

a cathode electrode plate being positioned proximate and interior of said first electro dialysis gasket being positioned at said first outer end;

at least one anode electrode plate being positioned proximate and interior of said second electro dialysis gasket being positioned at said second outer layer;

at least two membrane gaskets including a first membrane gasket being positioned proximate and interior of said cathode electrode plate, and a second membrane gasket being positioned proximate and interior of said anode electrode plate, said first membrane gasket and said second membrane gasket having a central opening therethrough and having a plurality of holes through each opposed end for passage of liquid mixtures therethrough;

said plurality of disparate layers including:

an anion membrane having a plurality of holes through each opposed end for passage of liquid mixtures therethrough;

a first electro dialysis membrane gasket having a central opening therethrough and having a plurality of holes through each opposed end for passage of liquid mixtures therethrough;

a first turbulence promoter layer being sized to fit proximate said opening within said first electro dialysis membrane gasket;

a cation membrane having a plurality of holes through each opposed end for passage of liquid mixtures therethrough;

a second electro dialysis membrane gasket having an opening therethrough and having a plurality of holes through each opposed end for passage of liquid mixtures therethrough; and

a second turbulence promoter layer being sized to fit proximate said opening within said second electro dialysis membrane gasket;

whereby said plurality of disparate layers being repeated in series, the liquid mixtures being passed through said electro dialysis cell stack;

connecting means for connection of said plurality of disparate layers within said support frame; and

a voltage being supplied by a voltage supply means, said voltage being applied as a voltage differential between said cathode electrode plate and said anode electrode plate;

whereby said electro dialysis cell stack including said plurality of disparate layers being repeated as required for purification and deionization of the liquid mixtures being passed therethrough.

12. The membrane cell stack of claim 11, wherein said electro dialysis cell stack further comprises a first electrode in contact with said cathode electrode plate, and a second electrode in contact with said at least one anode electrode plate for application of said voltage differential between said cathode electrode plate and said at least one anode electrode plate.

13. The membrane cell stack of claim 12, wherein said plurality of disparate layers being substantially parallel and being sized and shaped for being positioned within said support frame, said plurality of disparate layers further includes a plurality of turbulence promoter plates being positioned between said anion membrane and proximate said anode electrode plate.

14. The membrane cell stack of claim 13, wherein said first electro dialysis gasket and said second electro dialysis gasket being composed of ethylene propylene diene monomer of about 0.031 inch thickness.

13

15. The membrane cell stack of claim **14**, wherein said first membrane gasket and said second membrane gasket being composed of ethylene propylene diene monomer of about 0.062 inch thickness.

16. The membrane cell stack of claim **15**, wherein said turbulence promoter being composed of polypropylene fabric of about 0.030 inch thickness.

14

17. The membrane cell stack of claim **16**, wherein said first electro dialysis membrane gasket and second electro dialysis membrane gasket being composed of ethylene propylene diene monomer of about 0.031 inch thickness.

* * * * *