



US006250935B1

(12) **United States Patent**
Mochizuki et al.

(10) **Patent No.:** US 6,250,935 B1
(45) **Date of Patent:** Jun. 26, 2001

(54) **ELECTRICAL CONNECTOR**

FOREIGN PATENT DOCUMENTS

(75) Inventors: Shoichi Mochizuki, Yamanasi;
Yasuhiro Ono, Kanagawa, both of (JP)

WO 98/09354 * 3/1998 (WO).

* cited by examiner

(73) Assignee: Kel Corporation, Tokyo (JP)

(*) Notice: Subject to any disclaimer, the term of this patent is extended or adjusted under 35 U.S.C. 154(b) by 0 days.

Primary Examiner—Michael L. Gellner
Assistant Examiner—Kyung S. Lee
(74) Attorney, Agent, or Firm—Robert W. J. Usher

(21) Appl. No.: 09/299,343

(22) Filed: Apr. 26, 1999

(30) **Foreign Application Priority Data**

May 6, 1998 (JP) 10-123328

(51) Int. Cl.⁷ H01R 12/00; H05K 1/00

(52) U.S. Cl. 439/74; 439/108; 439/608

(58) Field of Search 439/74, 607, 608,
439/108, 660

(56) **References Cited**

U.S. PATENT DOCUMENTS

5,813,871 * 9/1998 Grabbe et al. 439/108
5,915,976 * 6/1999 McHugh 439/74

(57) **ABSTRACT**

A plug connector 10 includes a central grounding plate 13, which is provided between two lateral rows of signal plug contacts 12a. In these rows, grounding plug contacts 12b are positioned to partition the signal plug contacts 12a and to establish electrical contact with the central grounding plate 13. A receptacle connector 30 includes a pair of lateral grounding plates 33, which are positioned outside two lateral rows of signal receptacle contacts 32a. Grounding receptacle contacts 32b are provided at locations which correspond with the locations of the grounding plug contacts 12b and are in electrical connection to the lateral grounding plates 33. This electrical connector assembly has a relatively small number of parts yet prevents crosstalk and reflection of signals effectively.

5 Claims, 4 Drawing Sheets

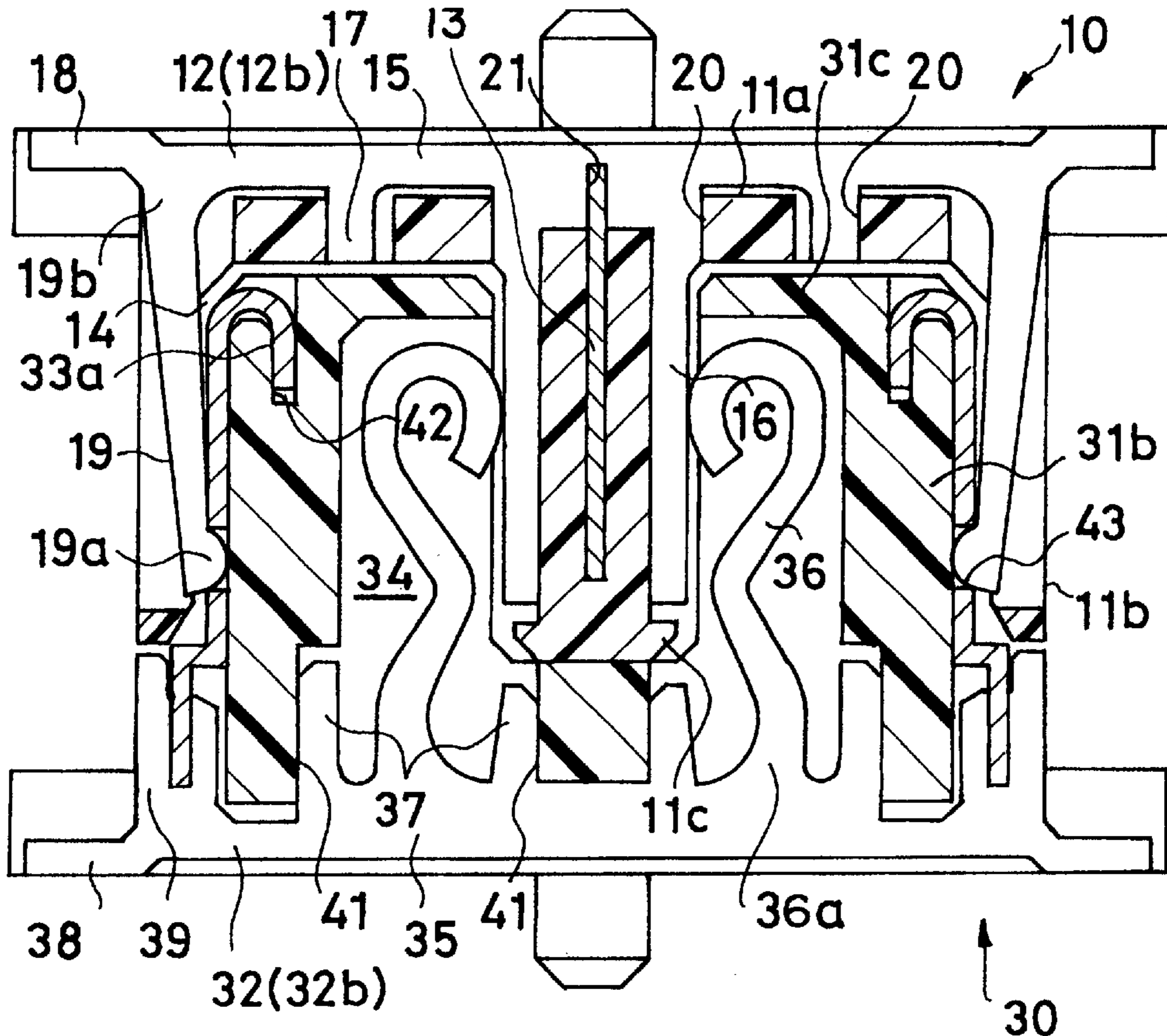

Fig. 1

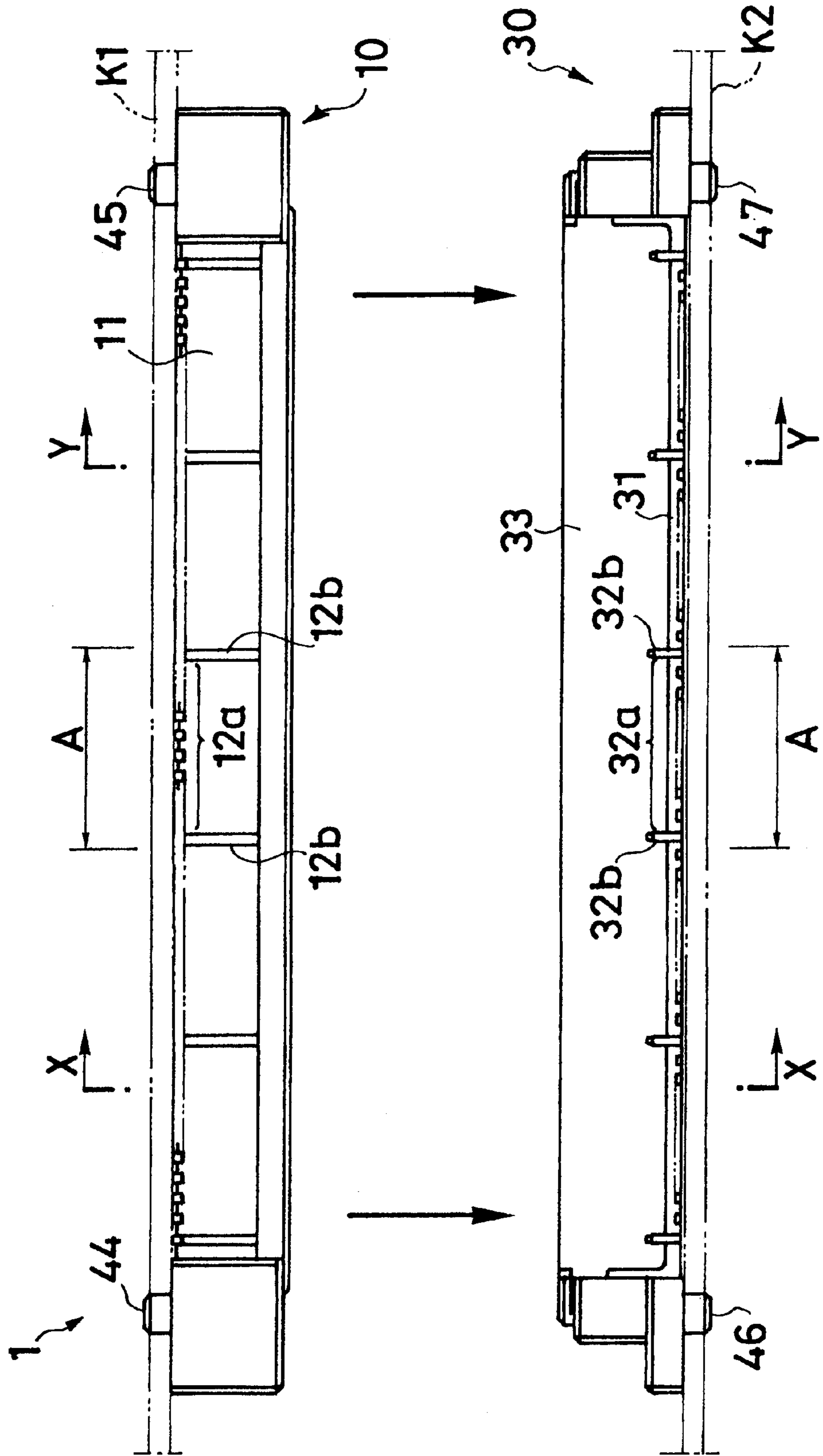

Fig. 2

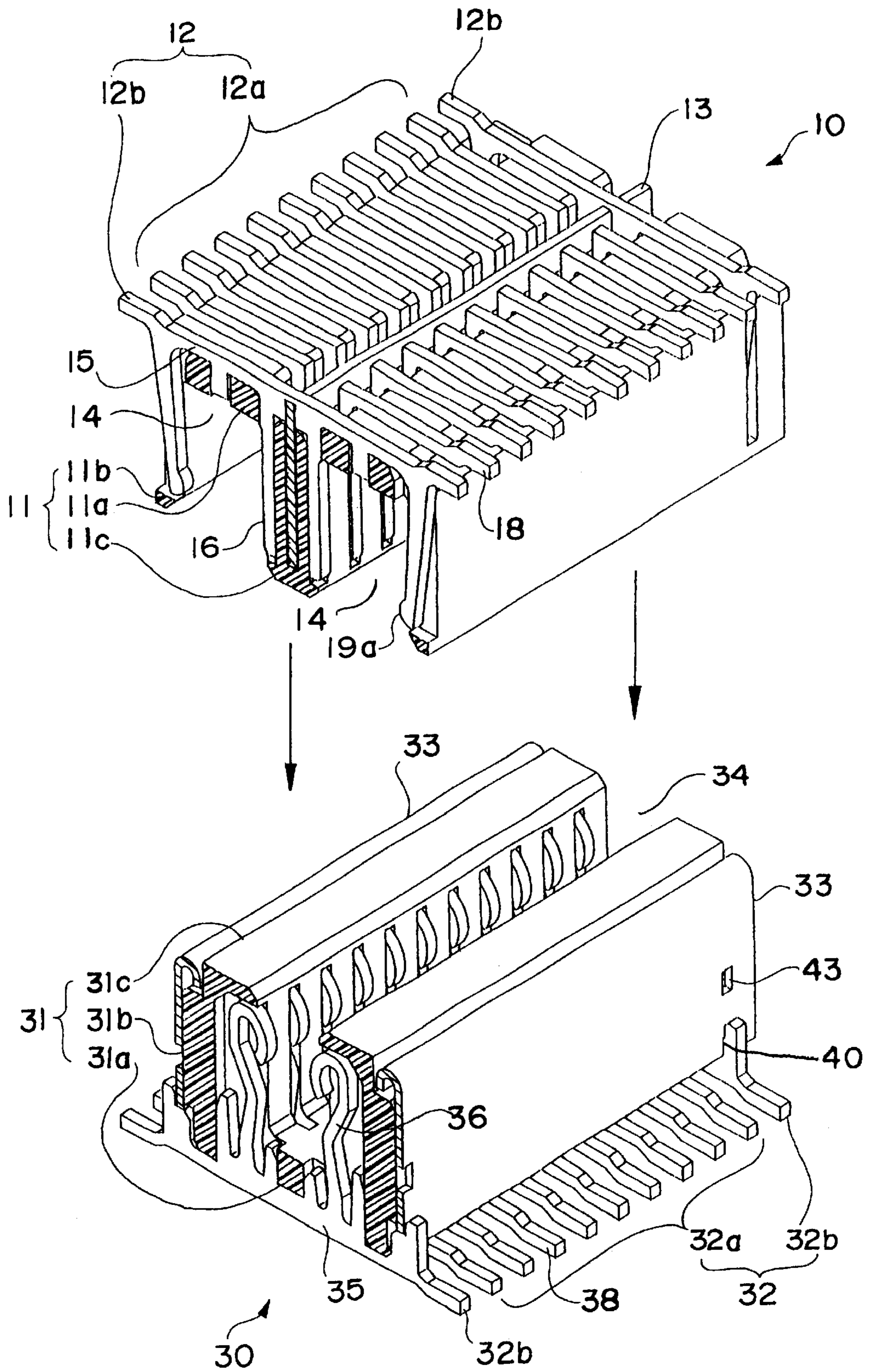
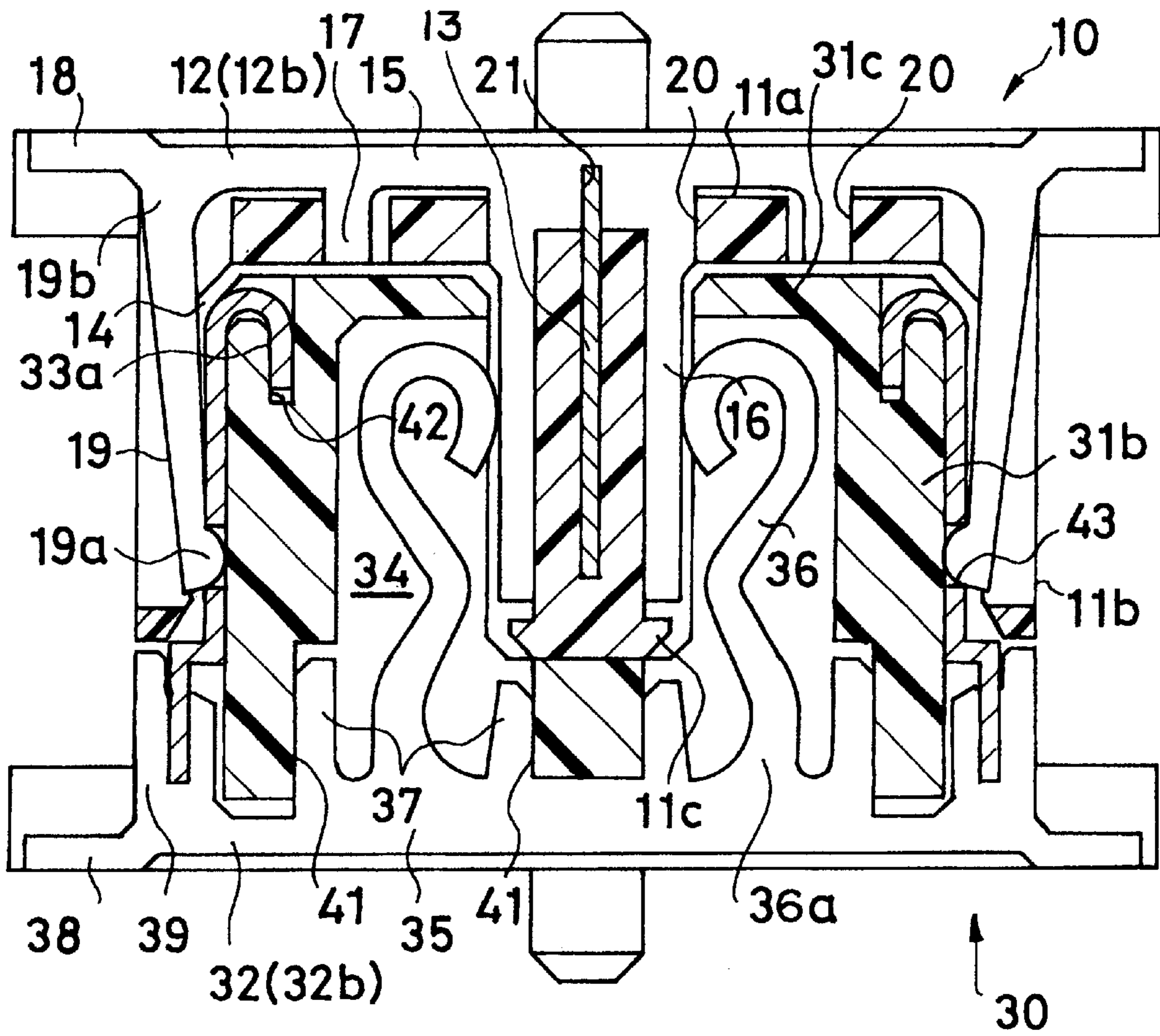

Fig. 4



ELECTRICAL CONNECTOR**FIELD OF THE INVENTION**

The present invention generally relates to an electrical connector assembly for signal transmission which has two intermatable, plug and receptacle connector halves, and more particularly to an electrical connector for high-speed signal transmission which has a plurality of electrical contacts aligned in rows with a relatively small pitch.

BACKGROUND OF THE INVENTION

An electrical connector assembly which is designed with intermatable connector halves for high-speed signal transmission is well known in the art. In this type of electrical connector, a plug connector half is designed with a plurality of plug contacts which are aligned on a convex feature provided in a housing while a receptacle connector half is designed with a plurality of receptacle contacts which are aligned on a concave feature provided in another housing. These plug and receptacle connectors are electrically connected to enable signal transmission when their respective housings are mated by inserting the convex portion of the plug connector into the concave portion of the receptacle connector and thereby the interconnecting corresponding pairs of plug and receptacle contacts. In this type of high-speed signal transmission connector, these electrical contacts are usually positioned with a relatively small pitch in the respective housings, so signal leak (i.e., crosstalk) between adjacent contacts is likely to happen. In addition, if there is a mismatch of impedance, then signal reflection is likely to occur. To prevent such problems, various methods are proposed.

One method is to provide a grounding plate in parallel with the rows of plug contacts which are aligned on opposite sides of the convex portion of the plug connector or in parallel with the rows of receptacle contacts which are aligned in the housing of the receptacle connector and to connect this grounding plate to a grounding pathway provided on a printed circuit board by using a special part.

However, in this method, the special part is designed especially for this grounding connection, so the provision of this special part increases the number of parts necessary for the production of the electrical connector, which is disadvantageous in reducing production cost. Beside this disadvantage, the existence of this special part, which is used solely for the electrical grounding of the electrical connector, creates an unwanted impedance characteristic. Moreover, a relatively long electrical pathway is required for connecting this special grounding part, which is provided in the electrical connector, to a grounding pathway which is provided on the printed circuit board. This long electrical pathway is a hindrance to any attempt which can be effected to improve the impedance characteristic of the electrical connector.

SUMMARY OF THE INVENTION

It is an object of the present invention to provide an electrical connector which has an improved impedance characteristic without increasing the number of parts used.

The scope of the present invention includes not only an independent plug connector and an independent receptacle connector but also a set of a plug connector and a receptacle connector which are intermatable.

A plug connector according to the present invention comprises a plug housing, a plurality of signal plug contacts

and a first grounding plate (e.g., the central grounding plate **13** of the embodiment described in the following section of this document). The plug housing includes a plug cavity, which opens in the direction for engagement with an intermatable receptacle connector. The signal plug contacts are aligned in lateral pairs, i.e., in two rows, in the plug cavity, these rows extending in the back-and-forth direction of the plug connector (an arbitrary direction which is defined in the following section for the purpose of description only). The first grounding plate extends between the lateral two rows of signal plug contacts also in the back-and-forth direction. In addition, the plug connector further includes a plurality of grounding plug contacts, which are provided substantially orthogonally to the first grounding plate, for partitioning the rows of signal plug contacts. The grounding plug contacts are in contact and electrical connection with the first grounding plate.

Preferably, the plug housing comprises lateral side walls, a base wall and a protrusion. The lateral side walls and the base wall define the plug cavity, and the protrusion protrudes from the base wall into the plug cavity, extending in the back-and-forth direction. Furthermore, each of the signal plug contacts and grounding plug contacts comprises a plug base portion (e.g., the base portion **15** of the following embodiment), which extends laterally, and a plug contact portion (e.g., the contact portion **16** of the following embodiment) which extends from the plug base portion to the opening of the plug cavity. The signal plug contacts and grounding plug contacts are mounted in the plug housing with the plug contact portions extending along the lateral side faces of the protrusion and the plug base portions extending along the base wall laterally outward. Moreover, the first grounding plate is positioned inside the protrusion of the plug housing, extending in the back-and-forth direction, and the portions of the first grounding plate which are exposed from the protrusion of the plug housing are set in contact with the central portions of the grounding plug contacts. Furthermore, plug lead portions (e.g., the lead portions **18** of the following embodiment) are provided as extensions to the plug base portions of the signal plug contacts and grounding plug contacts, and the plug lead portions are exposed to outside from the base wall. These lead portions are used for surface mounting the plug connector onto a circuit provided on a printed circuit board which is designed for the plug connector.

With this construction, the possibility of crosstalk which may be observable between the lateral pairs of signal plug contacts is very small, so the signal transmission characteristic of the connector is kept in good condition. In this construction, a plurality of grounding plug contacts are provided to partition the signal plug contacts into groups, so a plurality of electrically grounding pathways can be also provided in the circuit of the printed circuit board, to establish a plurality of grounding connections to the first grounding plate in substantially short distance. Thereby, the possibility of crosstalk is further reduced, and improvement can be made in the impedance characteristic or high-frequency characteristics of the connector.

In addition, because the grounding plug contacts are provided as parts of the electrical contacts which are placed in the plug housing, there is no need of providing separate parts such as special contacts used in the prior art, for the connection of the grounding plate to the grounding pathways, which are provided on the printed circuit board. Therefore, the electrical connector according to the present invention requires a relatively small number of parts, so it can avoid unfavorable impedance characteristic, which may be otherwise generated by adding such separate parts.

Furthermore, a receptacle connector according to the present invention comprises a receptacle housing, a plurality of signal receptacle contacts and a lateral pair of second grounding plates (e.g., the lateral grounding plates **33** of the following embodiment). The receptacle housing includes a receptacle cavity, which is open in the direction for engagement with the plug connector. The signal receptacle contacts are aligned in lateral pairs, i.e., in two rows, in the receptacle cavity, and these rows extend in the back-and-forth direction. The second grounding plates extend also in the back-and-forth direction but outside the lateral two rows of signal receptacle contacts. In addition, the receptacle connector further comprises a plurality of grounding receptacle contacts, which partition the rows of signal receptacle contacts into groups. The grounding receptacle contacts are positioned in the receptacle housing substantially orthogonally to the second grounding plates, at the locations which correspond with those of the grounding plug contacts in the plug connector, and the grounding receptacle contacts are in contact and electrical connection with the second grounding plates.

Preferably, the receptacle housing comprises lateral side walls and a base wall, which define the receptacle cavity. Furthermore, each of the signal receptacle contacts and grounding receptacle contacts comprises a receptacle base portion (e.g., the base portion **35** of the following embodiment), which extends laterally, and a receptacle contact portion (e.g., the contact portion **36** of the following embodiment), which extends from the receptacle base portion to the opening of the receptacle cavity. The signal receptacle contacts and the grounding receptacle contacts are mounted in the receptacle housing with the receptacle contact portions extending along inside faces of the lateral side walls and the receptacle base portions extending along the base wall laterally outward. In addition, the second grounding plates are provided outside the lateral side walls of the receptacle housing, each grounding plate on one lateral side wall. Moreover, receptacle lead portions (e.g., the lead portions **38** of the following embodiment) which are extensions of the receptacle base portions of the signal receptacle contacts and grounding receptacle contacts are exposed to outside from the base wall. These lead portions are surface mounted onto a circuit which is provided on a printed circuit board for the receptacle connector. In this construction, each of the grounding receptacle contacts may be formed in lateral symmetry in a one-piece body rather than separate, right and left halves. In this way, electrical noise coming from the outside environment is blocked as effectively as crosstalk is eliminated as described above.

Further scope of applicability of the present invention will become apparent from the detailed description given hereinafter. However, it should be understood that the detailed description and specific examples, while indicating preferred embodiments of the invention, are given by way of illustration only, since various changes and modifications within the spirit and scope of the invention will become apparent to those skilled in the art from this detailed description.

BRIEF DESCRIPTION OF THE DRAWINGS

The present invention will become more fully understood from the detailed description given herein below and the accompanying drawings which are given by way of illustration only and thus are not limitative of the present invention and wherein:

FIG. 1 shows a side view of an electrical connector assembly according to the present invention;

FIG. 2 shows a perspective, enlarged view of the section of the electrical connector assembly, which section is indicated by dimension line "A" in FIG. 1;

FIG. 3 shows a sectional view of a signal transmission portion of the electrical connector assembly in engagement; and

FIG. 4 shows a sectional view of a grounding portion of the electrical connector assembly in engagement.

DESCRIPTION OF THE PREFERRED EMBODIMENTS

As shown in FIG. 1 and FIG. 2 (FIG. 2 is a perspective view of the section A in FIG. 1), an electrical connector assembly **1** according to the present invention comprises a plug connector **10** and a receptacle connector **30**. These connector halves **10** and **30** are mated to each other to bring the electrical contacts **12** of the plug connector **10** and the electrical contacts **32** of the receptacle connector **30** into electrical contact for signal transmission. For the sake of convenience in description, the lateral direction of FIG. 1 is defined as "back-and-forth direction", the top-and-bottom direction thereof is defined as "up and down direction", and the direction perpendicular to the drawing thereof is defined as "lateral direction".

As shown in FIG. 2, the plug connector **10** has a plug housing **11** which is formed of an insulative material. This housing includes a horizontal base wall **11a**, lateral side walls **11b**, which extend downward from the lateral ends of the base wall **11a**, and a central protrusion **11c**, which protrudes downward from the center of the base wall **11a**. The plug connector **10** further comprises a plurality of plug contacts **12**, which are formed of an electrically conductive plate material and are aligned and retained in the plug housing **11**, and a central grounding plate **13**, which is made of an electrically conductive material and is positioned inside the central protrusion **11c**, extending in the back-and-forth direction.

As shown in FIG. 2, on the opposite sides of the central protrusion **11c** of the plug housing **11**, two lateral rows of plug contacts **12** are provided, each row extending in the back-and-forth direction. There are two types of plug contacts **12**: one for signal transmission and the other for electrical grounding. Each of the plug contacts **12a** for signal transmission has a "L" shape, and two signal plug contacts **12a** in a pair face each other on the opposite sides of the central grounding plate **13** in the plug housing **11**. Each of the plug contacts **12b** for grounding has a shape comparable to that in which a pair of signal plug contacts **12a** are combined into a one piece at the center top of the electrical connector, and each grounding plug contact **12b** is placed in a position which is comparable to that of a pair of signal plug contacts **12a**.

In the plug housing **11**, the lateral pairs of signal plug contacts **12a** are positioned in succession in the back-and-forth direction, and the grounding plug contacts **12b** are positioned to section these pairs of signal plug contacts **12a** into groups (nine pairs are sectioned into a group in this embodiment).

The receptacle connector **30** has a receptacle housing **31** which is formed of an insulative material. This housing includes a horizontal base wall **31a** and lateral side walls **31b**, which extend upward from the lateral ends of the base wall **31a**. The receptacle connector **30**, which is open upward, further comprises a plurality of plug contacts **32**, which are formed of an electrically conductive plate material and are aligned and retained in the receptacle housing **31**,

and two lateral grounding plates **33**, which are made of an electrically conductive material and are positioned laterally outside the receptacle housing **31**.

As shown in FIG. 2, inside the receptacle housing **31**, two lateral rows of receptacle contacts **32** are provided, each row extending in the back-and-forth direction. There are two types of receptacle contacts **32**: one for signal transmission and the other for electrical grounding. Each of the receptacle contacts **32a** for signal transmission generally has a “L” shape with its top end being curled inward. Each of the receptacle contacts **32b** for grounding has a shape comparable to that in which a pair of signal receptacle contacts **32a** are combined into a one piece at the center bottom of the electrical connector. The grounding receptacle contacts **32b** are positioned in a comparable way as the signal receptacle contacts **32a**.

In the receptacle housing **31**, the lateral pairs of signal receptacle contacts **32a** are positioned in succession in the back-and-forth direction, and the grounding receptacle contacts **32b** are positioned to section these pairs of signal receptacle contacts **32a** into groups (nine pairs are sectioned into a group in this embodiment).

As shown in FIG. 1 and FIG. 2, the signal plug contacts **12a** and the signal receptacle contacts **32a** are positioned appropriately such that the respective pairs of contacts come into electrical contact when the respective connector halves are mated to each other. Also, the grounding plug contacts **12b** and the grounding receptacle contacts **32b** are positioned appropriately such that the respective pairs come into electrical contact when the respective connector halves are mated to each other. Therefore, in the condition where the plug connector **10** and the receptacle connector **30** are in engagement, the signal plug contacts **12a** are in electrical connection with the corresponding signal receptacle contacts **32a** (the portions of the electrical connector assembly where the signal contacts are in electrical connection are referred to as “signal connection portions”), and the grounding plug contacts **12b** are in electrical connection with the grounding receptacle contacts **32b** (the portions of the electrical connector assembly where the grounding contacts are in electrical connection are referred to as “grounding connection portions”).

The plug connector **10** and the receptacle connector **30** are shown in engagement in FIG. 3 and FIG. 4. FIG. 3 is a cross-sectional view taken along line X—X in FIG. 1 (i.e., a view of a signal connection portion) while FIG. 4 is a cross-sectional view taken along line Y—Y in FIG. 1 (i.e., a view of a grounding connection portion). As both the connector halves **10** and **30** are laterally symmetrical, only one sides of the symmetrical portions are marked with numerals.

As shown in FIGS. 2, 3 and 4, the plug housing **11** of the plug connector **10** comprises the base wall **11a**, which is horizontally positioned, the lateral side walls **11b**, which extend downward from the lateral ends of the base wall **11a**, and the central protrusion **11c**, which protrudes downward from the center of the base wall **11a**. In this configuration, on the lower face of the base wall **11a**, plug cavities **14** are defined by the lateral side walls **11b** and the central protrusion **11c**, the cavities being open downward.

As shown in FIG. 3, the signal plug contact **12a** includes a base portion **15**, which extends horizontally near the upper part of the plug connector **10**, a contact portion **16**, which extends downward from the inside end of the base portion **15**, a protruding portion **17**, which extends downward at the middle part of the base portion **15**, and a lead portion **18**,

which is provided at the outside end of the base portion **15**. On the other hand, the grounding plug contacts **12b** includes the features of a pair of signal plug contacts **12a** in a shape which is comparable to that of the signal plug contacts **12a** combined into a one piece at the top of the electrical connector as shown in FIG. 4. Furthermore, the grounding plug contact **12b** includes a pair of arm portions **19** which extend downward near the lateral outside ends, and each of the arm portions **19** further includes a raised portion **19a**, which protrudes inward at the lower end thereof. In this configuration, the arm portions **19** are laterally resilient around the supporting portions **19b** of the arm portions **19**.

In the base wall **11a** and the central protrusion **11c** of the plug housing **11**, fitting slots **20** are provided for attaching the signal plug contacts **12a** and the grounding plug contacts **12b** (slots are also provided in the lateral side walls **11b** where the grounding plug contacts are positioned). During the assembly of the electrical connector, the contact portions **16** and the protruding portions **17** of the respective plug contacts are staked into these fitting slots **20**. As a result, a pair of signal plug contacts **12a** are placed at each of the signal connection portions as shown in FIG. 3 while a grounding plug contacts **12b** is placed at each of the grounding connection portions as shown in FIG. 4. In this condition, the contact portions **16** of the signal plug contacts **12a** and grounding plug contacts **12b** are positioned such that one lateral sides of the contact portions **16** are exposed into the plug cavities **14** while the lead portions **18** of the respective contacts are exposed from the upper face of the plug housing **11**. Thus, these plug contacts are aligned in the back-and-forth direction as shown in FIG. 2.

As shown in FIGS. 3 and 4, the central grounding plate **13** is press fit into the central protrusion **11c** of the plug housing **11** in the back-and-forth direction. This grounding plate **13** is insulated from the lateral signal plug contacts **12a** at the signal connection portions by the central protrusion **11c** of the housing while being in contact with the grounding plug contacts **12b** at the grounding connection portions, with the upper end of the central grounding plate **13** being fit into engaging slots **21** which are provided in the grounding plug contacts **12b**. Therefore, the central grounding plate **13** is electrically connected only to the grounding plug contacts **12b**.

The lead portions **18** of the signal plug contacts **12a** and grounding plug contacts **12b**, which portions are exposed from the upper surface of the base wall **11a** of the plug housing **11**, are mounted on a surface of a printed circuit board **K1** which is provided for the plug connector as shown in FIG. 1. A pair of positioning pins **44** and **45** are provided on the upper face of the plug housing **11** each at the opposite end in the back-and-forth direction, and these positioning pins are inserted into the positioning holes which are provided on the printed circuit board **K1** for accurate positioning of the plug connector onto the printed circuit board. After this positioning, the signal plug contacts **12a** and the grounding plug contacts **12b** are surface mounted on the printed circuit board by soldering each respective contact to a corresponding electrical pathway of a circuit pattern for signal transmission or for electrical grounding, respectively.

The receptacle housing **31** of the receptacle connector **30** comprises the base wall **31a**, which is horizontally positioned (the portion illustrated with hatching in FIGS. 3 and 4 is only a central portion of the base wall **31a**), and the lateral side walls **31b**, which extend upward from the lateral ends of the base wall **31a**. The upper end portions **31c** of the lateral side walls **31b** extend horizontally inward, so the receptacle cavity **34** is defined by the lateral side walls **31b** and the upper end portions **31c**.

As shown in FIG. 3, the signal receptacle contacts **32a** includes a base portion **35**, which extends horizontally, a contact portion **36**, which extends upward from the inside end of the base portion **35** and curls inward at its upper end, an anchoring portion **37**, which extends upward from the base portion **35** on the opposite sides of the contact portion **36**, and a lead portion **38**, which is provided at the outside end of the base portion **35**. Furthermore, the contact portion **36** is laterally resilient around a supporting portion **36a** which is the part near the base portion.

On the other hand, the grounding receptacle contact **32b** includes the features of a pair of signal receptacle contacts **32a** in a shape which is comparable to that of the signal receptacle contacts **32a** combined into a one piece at the bottom of the electrical connector as shown in FIG. 4. Furthermore, the grounding receptacle contact **32b** includes a pair of bifurcated holders **39**, which extend upward at the lateral outside ends thereof.

In the base wall **31a** of the receptacle housing **31**, fitting slots **41** are provided in the up and down direction for attaching the signal receptacle contacts **32a** and the grounding receptacle contacts **32b**. During the assembly of the electrical connector, the anchoring portions **37** of the respective receptacle contacts are staked into these fitting slots **41**. As a result, a pair of signal receptacle contacts **32a** are placed at each of the signal connection portions as shown in FIG. 3 while a grounding receptacle contact **32b** is placed at each of the grounding connection portions as shown in FIG. 4. In this condition, the contact portions **36** of the signal receptacle contacts **32a** and grounding receptacle contacts **32b** are positioned in the receptacle cavity **34** with a central space between the lateral respective pairs of contact portions **36**. While both connector halves **10** and **30** are not mated, this space remains a little narrower than the lateral width of the central protrusion **11c** of the plug housing **11**. The lead portions **38** of the signal receptacle contacts **32a** and grounding receptacle contacts **32b** are exposed from the lower face of the base wall **31a** of the housing. Thus, the lead portions **38** of the respective receptacle contacts are aligned in the back-and-forth direction as shown in FIG. 2.

As shown in FIGS. 2, 3 and 4, the lateral grounding plates **33** are attached on the lateral side walls **31b** of the receptacle housing **31**. Each lateral grounding plate **33** extends in the back-and-forth direction and has a bent portion **33a**, which is formed by folding the upper end of the grounding plate inwardly. This bent portion **33a** is press fit into a groove **42** which is provided at the upper end of each lateral side wall **31b** of the housing, and thereby the lateral grounding plates **33** are mounted on the receptacle housing. In this condition, these lateral grounding plates **33** are insulated from the signal receptacle contacts **32a** at the signal connection portions by the lateral side walls **31b** of the housing while being in contact with the grounding receptacle contacts **32b** at the grounding connection portions, with the lateral grounding plates **33** being fit into the grooves **40** of the holders **39** of the grounding receptacle contacts **32b** (refer to FIG. 2). It should be noted that the lateral grounding plates **33** are electrically connected only to the grounding receptacle contacts **32b**. Moreover, dents (or holes) **43** are provided on the outer faces of the lateral grounding plates **33** at the locations where the grounding receptacle contacts **32b** are positioned in the back-and-forth direction.

The lead portions **38** of the signal receptacle contacts **32a** and grounding receptacle contacts **32b**, which portions are exposed from the lower surface of the base wall **31a** of the receptacle housing **31**, are mounted on a surface of a printed circuit board **K2** which is provided for the receptacle con-

connector as shown in FIG. 1. A pair of positioning pins **46** and **47** are provided on the lower face of the receptacle housing **31**, each at the opposite end in the back-and-forth direction, and these positioning pins are inserted into the positioning holes which are provided on the printed circuit board **K2** for accurate positioning of the receptacle connector to the printed circuit board. After this positioning, the signal receptacle contacts **32a** and the grounding receptacle contacts **32b** are surface mounted on the printed circuit board by soldering each respective contact to a corresponding electrical pathway of a circuit for signal transmission or for electrical grounding, respectively.

The plug connector **10** and the receptacle connector **30** constructed as described above are engaged by inserting and fitting the protruding portions of the receptacle connector **30**, which are covered laterally with the grounding plates **33**, into the plug cavities **14** of the plug connector **10**, and thereby inserting and fitting the central protrusion **11c** of the plug connector **10** into the space between the upper end portions **31c** and then into the receptacle cavity **34** of the receptacle connector **30**. While both the connector halves **10** and **30** are being brought into engagement, the contact portions **16** of the plug contacts, which are placed laterally on the opposite sides of the central protrusion **11c**, meet, open and bend the contact portions **36** of the receptacle contacts, which are standing in the receptacle cavity **34**, laterally outward around the supporting portions **36a** of the contact portions **36**, which experience elastic deformation. As a result, the contact portions **36** of the receptacle contacts **32** are retained in contact and electrical connection with the contact portions **16** of the plug contacts **12** with a sufficient contact pressure.

In addition, while the plug connector **10** and the receptacle connector **30** are being mated to each other, the arm portions **19** of the grounding plug contacts **12b** are opened laterally by the insertion of the bent portions **33a** of the lateral grounding plates **33** of the receptacle connector. When both the connector halves **10** and **30** are brought into complete engagement, the raised portions **19a** of the arm portions **19** enter the dents **43** of the lateral grounding plates **33**. As a result, both the connector halves **10** and **30** are firmly engaged and retained to each other. A click sound is generated at the insertion of the raised portions **19a** into the dents **43**, so the correct engagement of the connector halves **10** and **30** can be audibly confirmed.

The electrical connector assembly **1**, which is used for signal transmission in this engaged condition, has an advantage in the prevention of crosstalk in the connector assembly. More specifically, the possibility of crosstalk which may be observable between the lateral pairs of signal plug contacts **12a** is very small because of the provision of a strip line, i.e., the central grounding plate **13**, which is positioned between the lateral pairs of signal plug contacts **12a** and positioned between the lateral grounding plates **33**, which are electrically grounded through the grounding plug contacts **12b** and grounding receptacle contacts **32b** to the electrically grounding pathways provided on the plug connector printed circuit board **K1** and the receptacle connector printed circuit board **K2**. Therefore, the signal transmission characteristic of the electrical connector assembly **1** is superior to conventional electrical connectors. Moreover, electrical noise coming from the outside environment to the electrical connector assembly **1** is absorbed into the lateral grounding plates **33** of the receptacle connector **30**, which are electrically grounded through the grounding receptacle contacts **32b** to the electrically grounding pathway provided on the receptacle connector printed circuit board **K2**. Therefore, the electrical connector assembly **1** is also immune to outside noise.

As described above, the grounding plug contacts **12b** and the grounding receptacle contacts **32b** are provided as parts of the electrical contacts which are placed in the plug housing **11** and the receptacle housing **31**, respectively. There is no need of providing such special contacts as used in the prior art, for the connection of the central grounding plate **13** and lateral grounding plates **33** to the grounding pathways provided on the printed circuit boards. Therefore, the electrical connector assembly according to the present invention requires a relatively small number of parts, so it can avoid unfavorable impedance characteristic.

In addition, as described above, the electrical connector assembly according to the present invention comprises a plurality of grounding plug contacts **12b** and grounding receptacle contacts **32b**, which are provided to partition the signal plug contacts **12a** and the signal receptacle contacts **32a** into groups, respectively. With this construction, the electrical connector assembly enables a plurality of electrically grounding pathways to be provided in the circuits of the respective printed circuit boards, for connection to the central grounding plate **13** and lateral grounding plates **33**. Therefore, the grounding lines of the central grounding plate **13** and lateral grounding plates **33** can be relatively short, so improvement can be made in impedance matching, thereby further reducing the possibility of crosstalk.

Furthermore, as another embodiment according to the present invention, each of the grounding receptacle contacts **32b** can be designed also in two separate symmetrical parts in a similar way as the signal receptacle contacts **32a**.

The invention being thus described, it will be obvious that the same may be varied in many ways. Such variations are not to be regarded as a departure from the spirit and scope of the invention, and all such modifications as would be obvious to one skilled in the art are intended to be included within the scope of the following claims.

RELATED APPLICATIONS

This application claims the priority of Japanese Patent Application No. PH10-123328 filed on May 6, 1998, which is incorporated herein by reference.

What is claimed is:

1. A plug connector comprising:

- a plug housing including a plug cavity, which is open in a direction for engagement with a receptacle connector;
- a plurality of signal plug contacts being aligned in lateral pairs, i.e., in two rows, in said plug cavity, said rows extending in a back-and-forth direction;
- a first grounding plate, which extends between said lateral two rows of signal plug contacts in said back-and-forth direction; and
- a plurality of grounding plug contacts for partitioning said rows of signal plug contacts, said grounding plug contacts being positioned to extend laterally to said first grounding plate and in contact and electrical connection with said first grounding plate; wherein:
 - said plug housing comprises lateral side walls, a base wall and a protrusion, said lateral side walls and said base wall defining said plug cavity, said protrusion protruding from said base wall into said plug cavity and extending in said back-and-forth direction along a lateral center of said plug housing;
 - each of said signal plug contacts and said grounding plug contacts comprises a plug base portion, which extends laterally, and a plug contact portion, which extends from said plug base portion to the opening of said plug cavity;

said signal plug contacts and said grounding plug contacts are mounted in said plug housing with said plug contact portions extending along lateral side faces of said protrusion and said plug base portions extending along said base wall laterally outward; said first grounding plate is provided inside said protrusion of said plug housing, extending in said back-and-forth direction;

portions of said first grounding plate which are exposed from said protrusion are in contact with central portions of said grounding plug contacts; and

plug lead portions which are extensions of said plug base portions of said signal plug contacts and said grounding plug contacts are exposed to outside from said base wall, said plug lead portions being for surface mounting said plug connector onto circuits provided on a plug-side printed circuit board.

2. A receptacle connector comprising:

a receptacle housing including a receptacle cavity, which is open in a direction for engagement with a plug connector;

a plurality of signal receptacle contacts being aligned in lateral pairs, i.e., in two rows, in said receptacle cavity, said rows extending in a back-and-forth direction;

a lateral pair of second grounding plates, which extend in said back-and-forth direction outside said lateral two rows of signal receptacle contacts; and

a plurality of grounding receptacle contacts for partitioning said rows of signal receptacle contacts, said grounding receptacle contacts being positioned to extend laterally to said second grounding plates and in contact and electrical connection with said second grounding plates, wherein:

said receptacle housing comprises lateral side walls and a base wall, which define said receptacle cavity;

each of said signal receptacle contacts and said grounding receptacle contacts comprises a receptacle base portion, which extends laterally, and a receptacle contact portion, which extends from said receptacle base portion to the opening of said receptacle cavity; said signal receptacle contacts and said grounding receptacle contacts are mounted in said receptacle housing with said receptacle contact portions extending along inside faces of said lateral side walls and said receptacle base portions extending along said base wall laterally outward;

said second grounding plates are positioned outside said lateral side walls of said receptacle housing, each grounding plate on one lateral side wall; and receptacle lead portions which are extensions of said receptacle base portions of said signal receptacle contacts and said grounding receptacle contacts are exposed to outside from said base wall, said receptacle lead portions being for surface mounting said receptacle connector onto circuits provided on a receptacle-side printed circuit board.

3. The connector set forth in claim **2** wherein each of said grounding receptacle contacts is formed in lateral symmetry in a one-piece body.

4. An electrical connector comprising a plug connector and a receptacle connector, both of which are mated with each other for signal transmission, wherein:

said plug connector comprises:

a plug housing including a plug cavity, which is open in a direction for engagement with a receptacle connector;

11

a plurality of signal plug contacts being aligned in lateral pairs, i.e., in two rows, in said plug cavity, said rows extending in a back-and-forth direction;

a first grounding plate, which extends between said lateral two rows of signal plug contacts in said back-and-forth direction; and

a plurality of grounding plug contacts for partitioning said rows of signal plug contacts, said grounding plug contacts being positioned to extend laterally to said first grounding plate and in contact and electrical connection with said first grounding plate; and

said receptacle connector comprises:

a receptacle housing including a receptacle cavity, which is open in a direction for engagement with said plug connector;

a plurality of signal receptacle contacts being aligned in lateral pairs, i.e., in two rows, in said receptacle cavity, said rows extending in back-and-forth direction;

a lateral pair of second grounding plates, which extend in said back-and-forth direction outside said lateral two rows of signal receptacle contacts; and

a plurality of grounding receptacle contacts for partitioning said rows of signal receptacle contacts, said grounding receptacle contacts being positioned substantially orthogonally to said second grounding plates and in contact and electrical connection with said second grounding plates; and

12

when said plug connector and said receptacle connector are mated with each other, said signal plug contacts come into contact with said signal receptacle contacts, respectively, and said grouping plug contacts come into contact with said grounding receptacle contacts, respectively, wherein:

each of said grounding plug contacts includes a plug base portion, plug contact portions and arm portions, said arm portions extending in parallel with and in a same direction as said plug contact portions from lateral outside ends of said plug base portion; and

when said plug connector and said receptacle connector are mated with each other, said arm portions come into contact with said second grounding plates.

5. The electrical connector set forth in claim 4 wherein:

said arm portions include raised portions, which protrude laterally inward from ends of said arm portions; and

when said plug connector and said receptacle connector are brought into engagement with each other, said raised portions come into and engage with dents which are provided on said second grounding plates and generate a clicking sound.

* * * * *