



US006217190B1

(12) **United States Patent**
Altman et al.

(10) **Patent No.:** **US 6,217,190 B1**
(45) **Date of Patent:** ***Apr. 17, 2001**

(54) **LIGHTING ASSEMBLY FOR MULTIPLE
FLUORESCENT LAMPS**

5,392,039 2/1995 Thurston .
5,720,546 2/1998 Correll, Jr. et al. 362/221
5,907,218 * 5/1999 Altman et al. 315/56
6,079,851 * 6/2000 Altman et al. 362/260

(75) Inventors: **Barry Eddington Altman**,
Mechanicsburg, PA (US); **John Francis
Turner**, Clemmons, NC (US);
Kimberly Ann Ketelsleger,
Mechanicsburg, PA (US)

OTHER PUBLICATIONS

Schreier, R., and Snelgrove, M., "Bandpass Sigma-Delta Modulation," *Electronic Letters*, vol. 25, No. 23 (Nov. 9, 1989): 1560-1561.

(73) Assignee: **The Whitaker Corporation**,
Wilmington, DE (US)

Raghavan et al.; "A Bandpass $\Sigma\Delta$ Modulator with 92dB SNR and Center Frequency Continuously Programmable from 0 to 70MHz," *IEEE International Solid-State Circuits Conference*, (1997): 214-215.

(*) Notice: Subject to any disclaimer, the term of this patent is extended or adjusted under 35 U.S.C. 154(b) by 0 days.

Shoaei, Omid and Snelgrove, W. Martin, "Multifeedback Design for LC Bandpass Delta-Sigma Modulators," *IEEE International Symposium on Circuits and Systems (ISCAS)*, vol. 1 (1995): 171-174.

This patent is subject to a terminal disclaimer.

* cited by examiner

(21) Appl. No.: **09/158,191**

Primary Examiner—Sandra O'Shea
Assistant Examiner—Anabel M. Ton

(22) Filed: **Sep. 21, 1998**

(57) **ABSTRACT**

Related U.S. Application Data

(60) Provisional application No. 60/060,661, filed on Oct. 2, 1997.

A fluorescent lighting assembly (2) includes a ballast lampholder subassembly (4) located at one end of a troffer (80) and at least one lampholder connector (50) located at the opposite end. The ballast lampholder subassembly (4) includes ballast circuitry connected to fluorescent lamp terminals (17) all positioned within a ballast lampholder housing (6). A molded ballast lampholder cover (8) encloses three sides of the ballast lampholder subassembly and a stamped metal plate forms the ballast lampholder base (10), with the ballast circuitry located on a circuit board (27) positioned on the interior surface of the base. Integrally molded lampholders (15) extend from channels (14) on the cover (8) and are positioned between larger enclosure sections (12) which provide space for larger ballast components. Fluorescent lamp terminals (17) are inserted from the interior of the cover into cavities (16) in lampholders (15), and lead wires connect the terminals to the printed circuit board. Lampholder connectors (50) including integrally molded lampholders (51) are located at the opposite end of the fluorescent lighting assembly (2).

(51) **Int. Cl.**⁷ **F21K 27/00**

(52) **U.S. Cl.** **362/221; 362/222; 362/265; 362/217; 362/260**

(58) **Field of Search** **362/221, 222, 362/265, 217, 260**

(56) **References Cited**

U.S. PATENT DOCUMENTS

3,996,493	*	12/1976	Davenport et al.	315/58
4,857,928		8/1989	Gailus et al. .	
5,003,232		3/1991	Venderbosch	315/312
5,013,253		5/1991	Aiello et al.	439/235
5,138,528	*	8/1992	Altman	362/400
5,140,324		8/1992	Przybysz et al. .	
5,198,815		3/1993	Przybysz et al. .	
5,327,130		7/1994	Kang et al. .	
5,341,136		8/1994	Przybysz et al. .	
5,345,406		9/1994	Williams .	
5,349,508	*	9/1994	Karraf	362/217

20 Claims, 9 Drawing Sheets

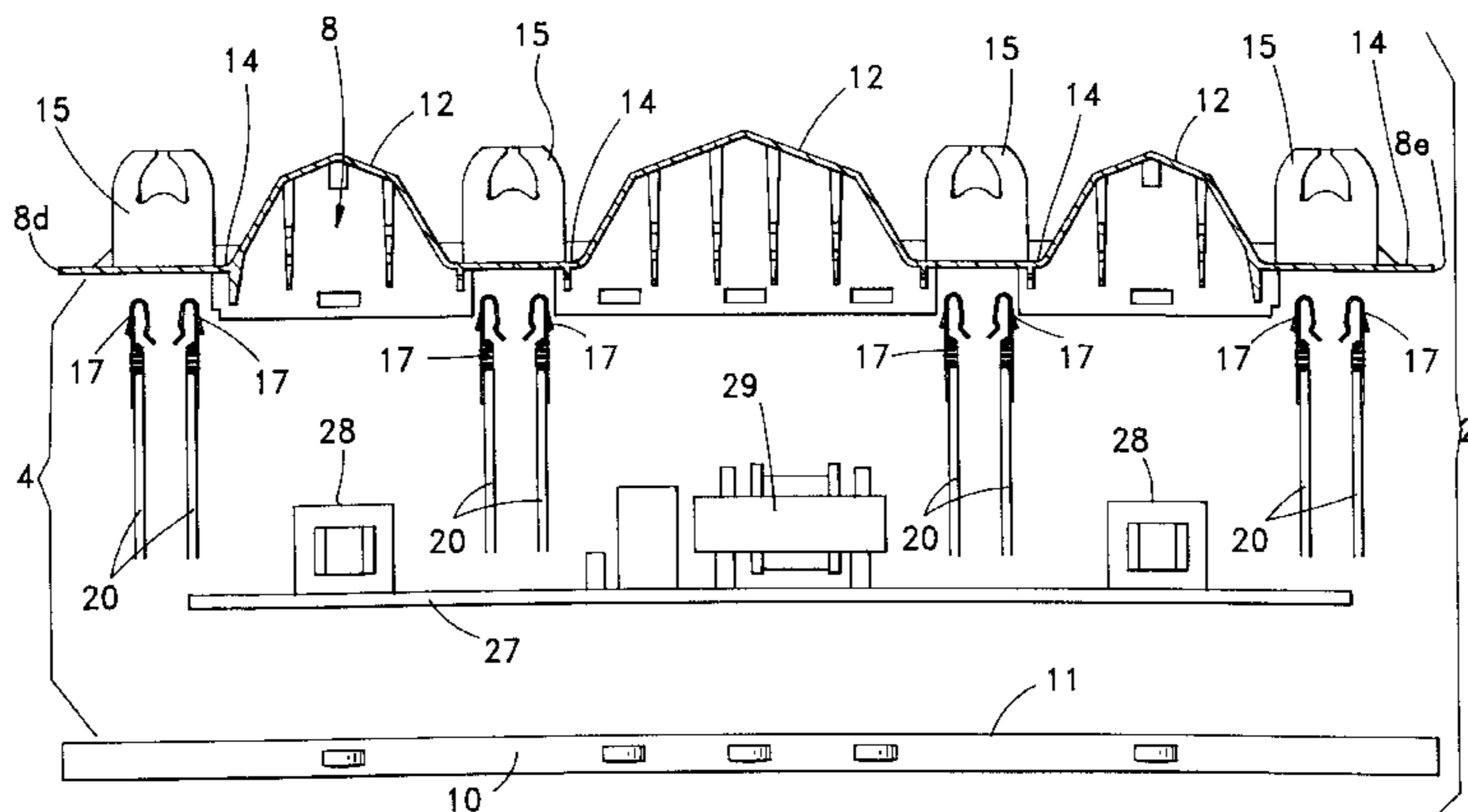

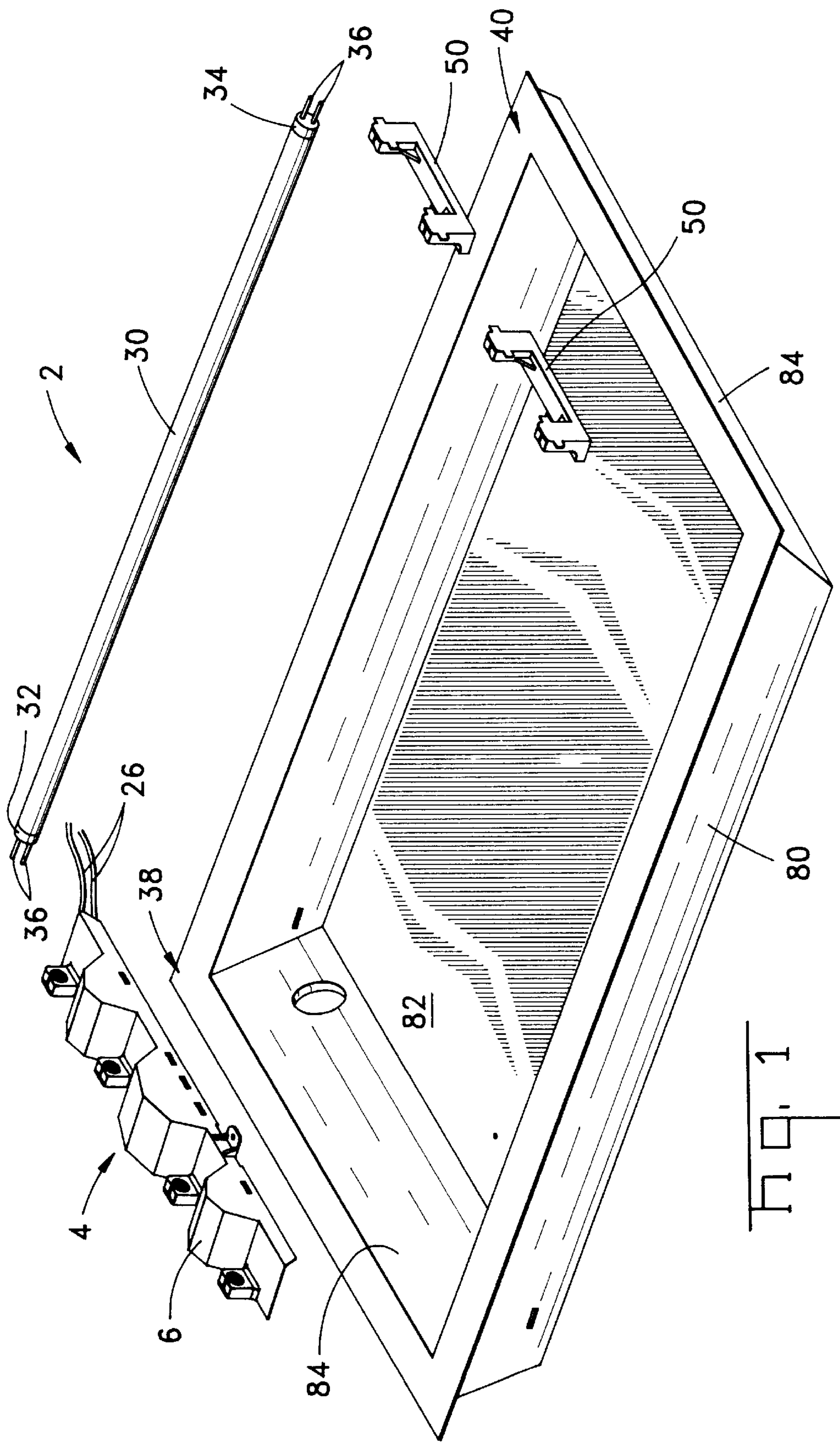

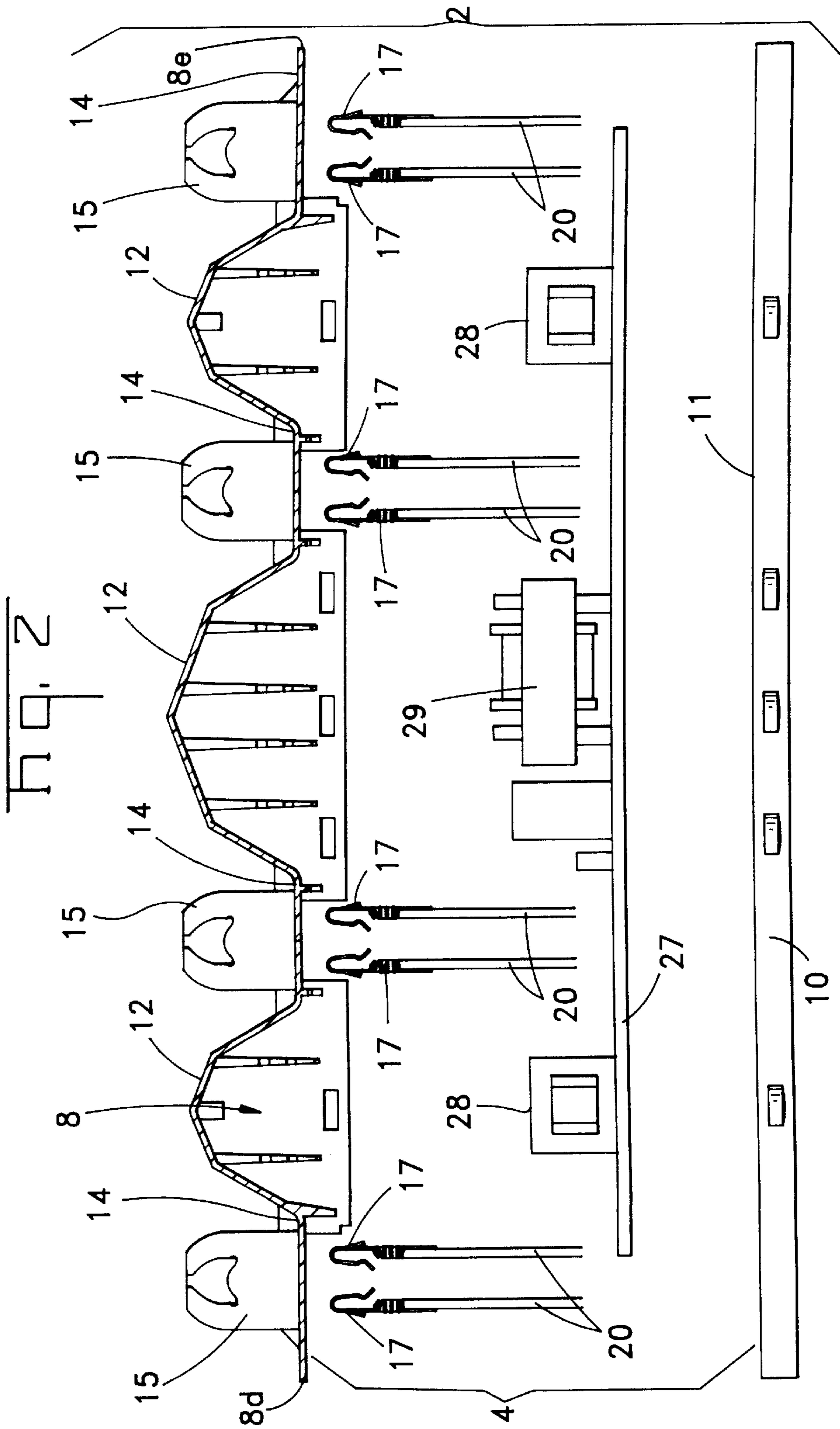

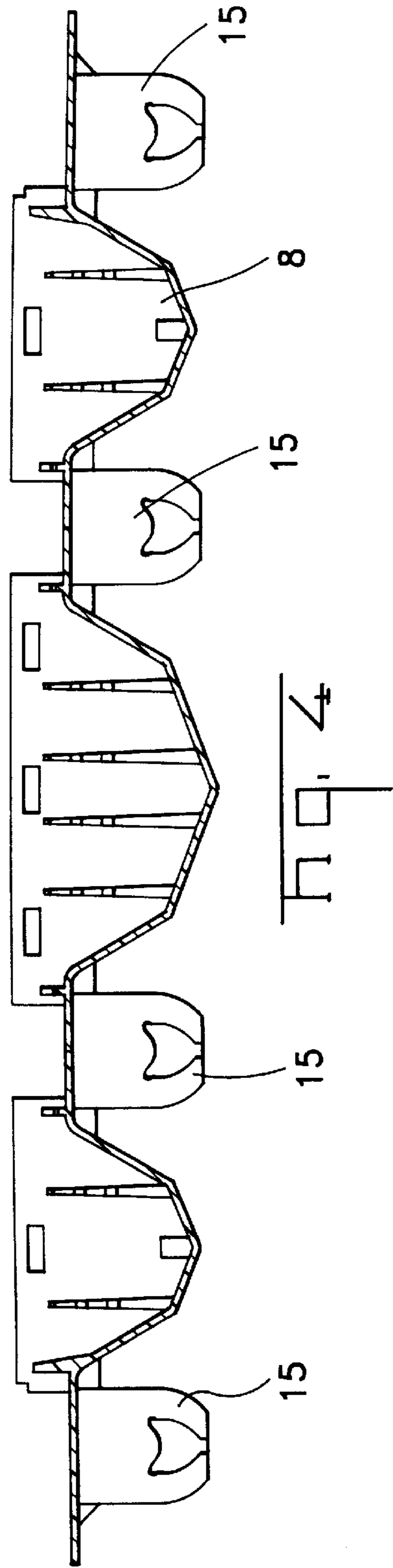
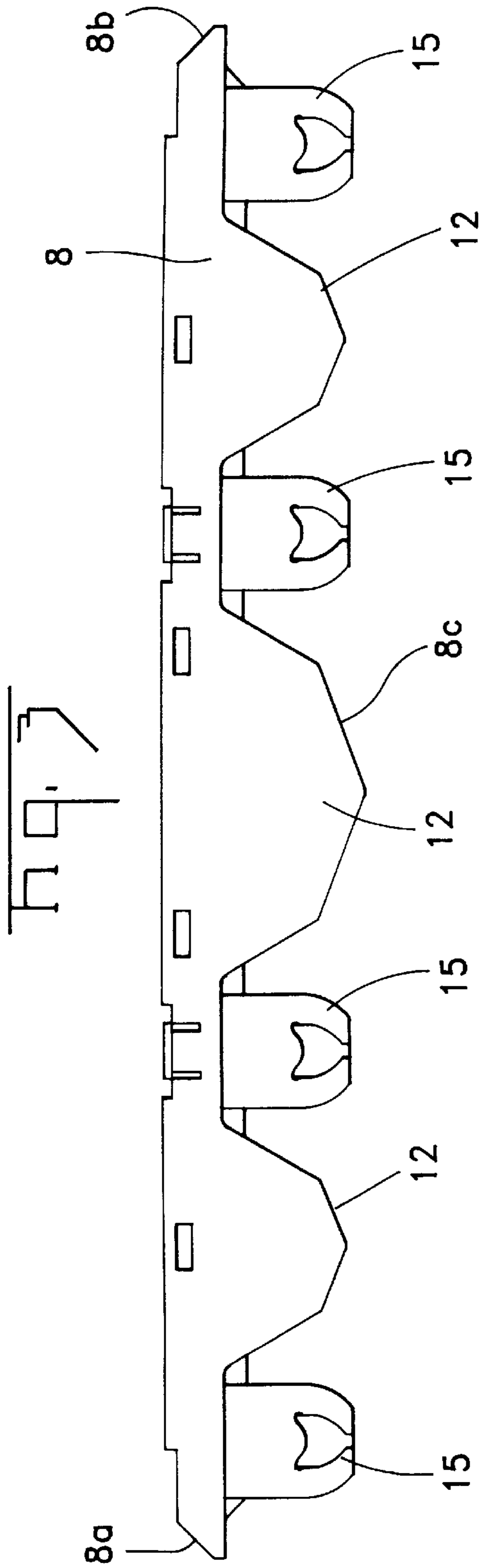

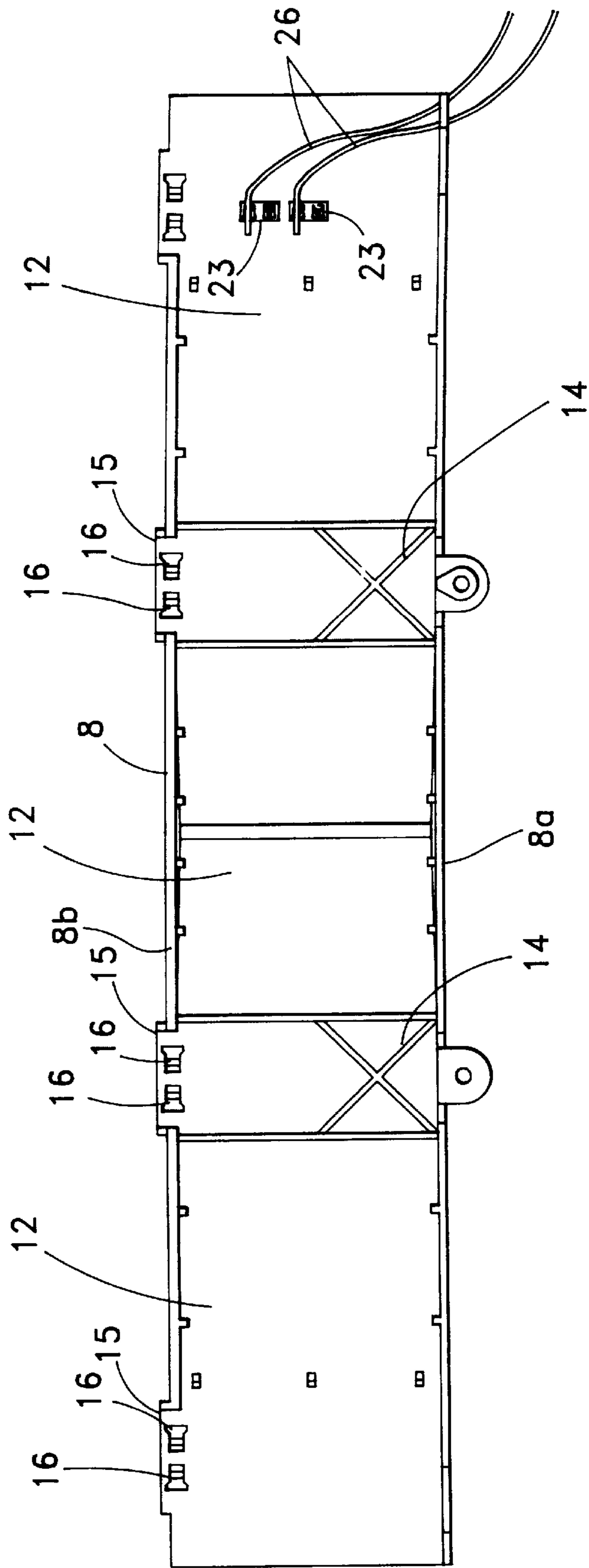

Fig. 5

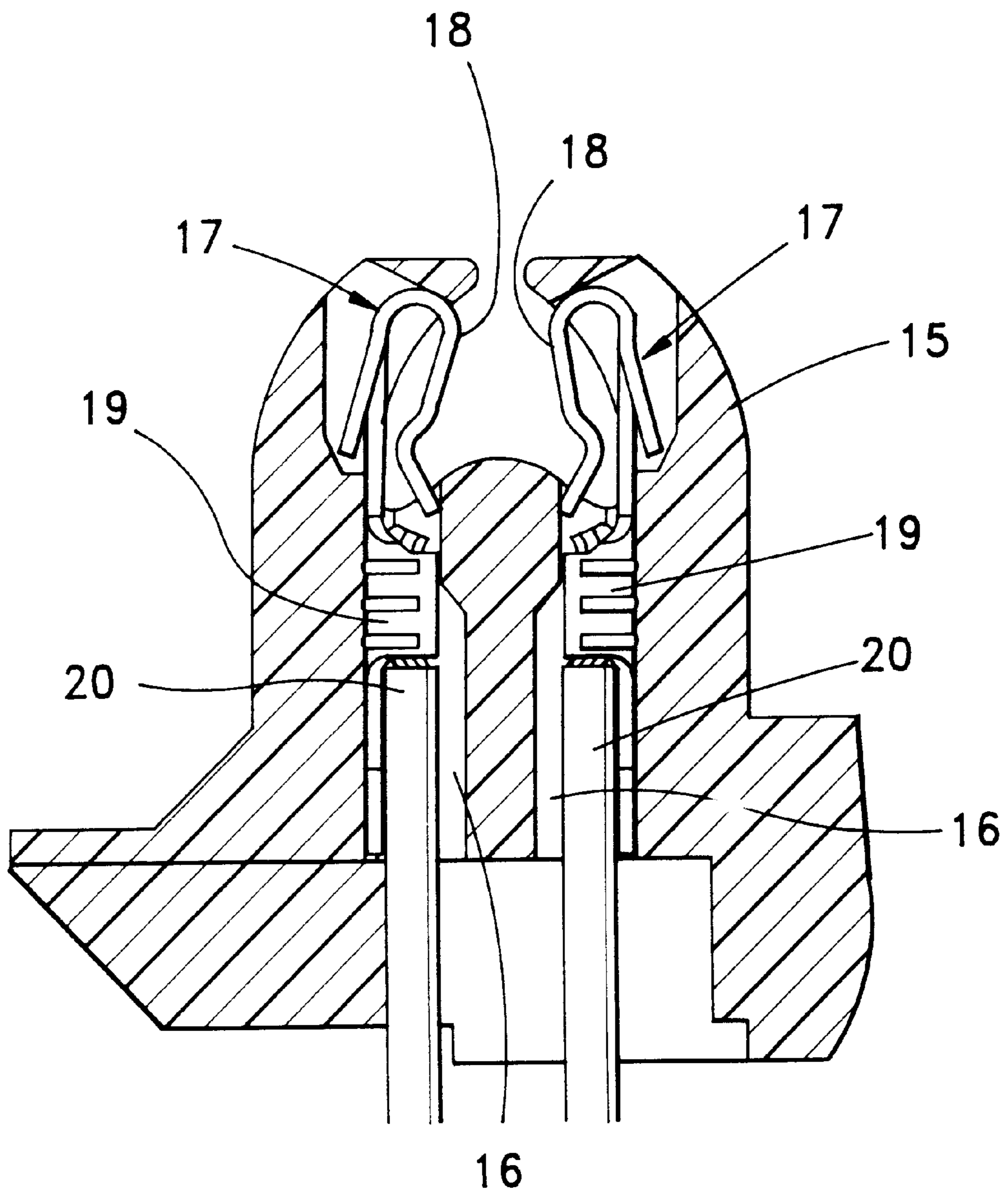
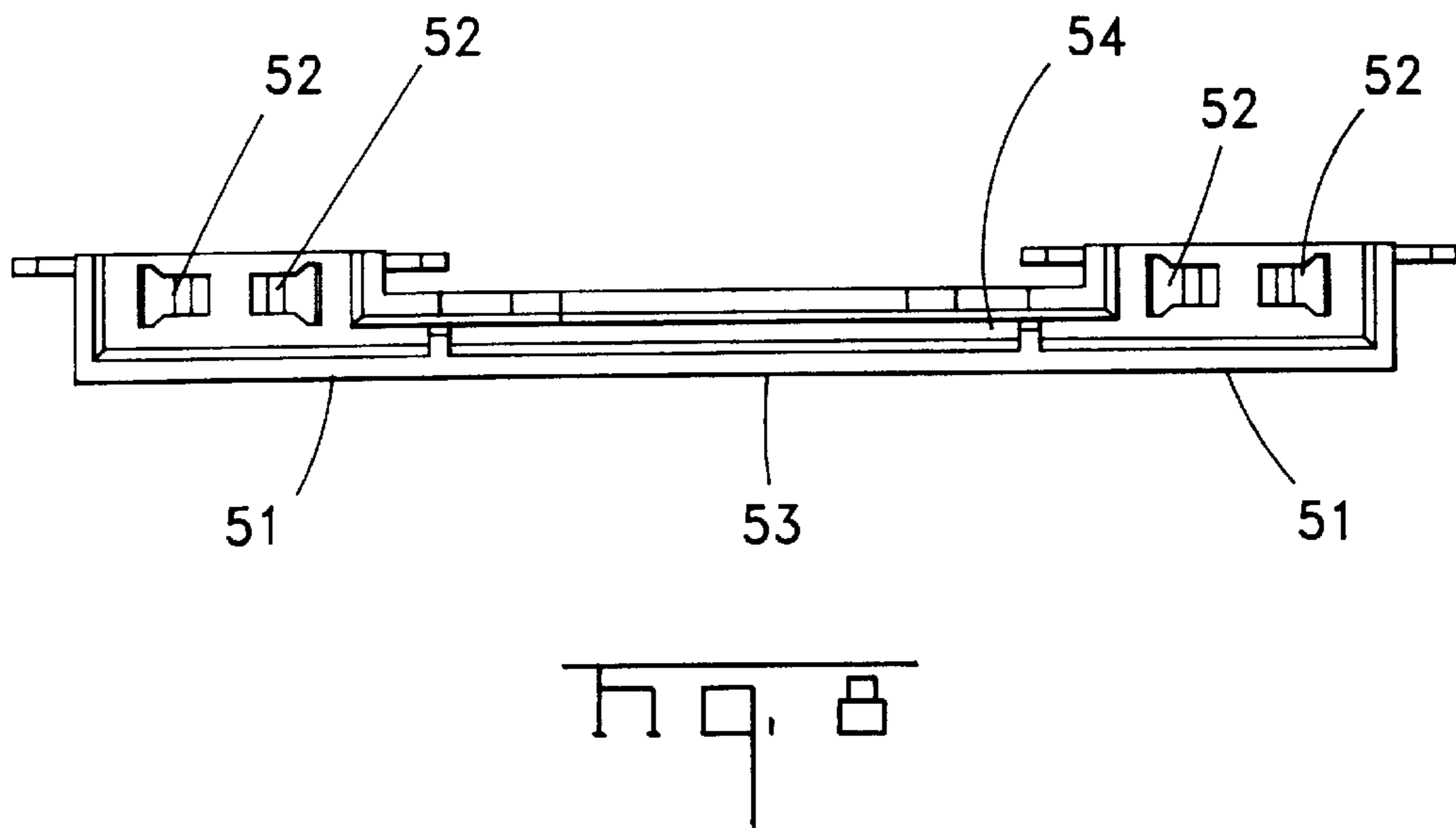
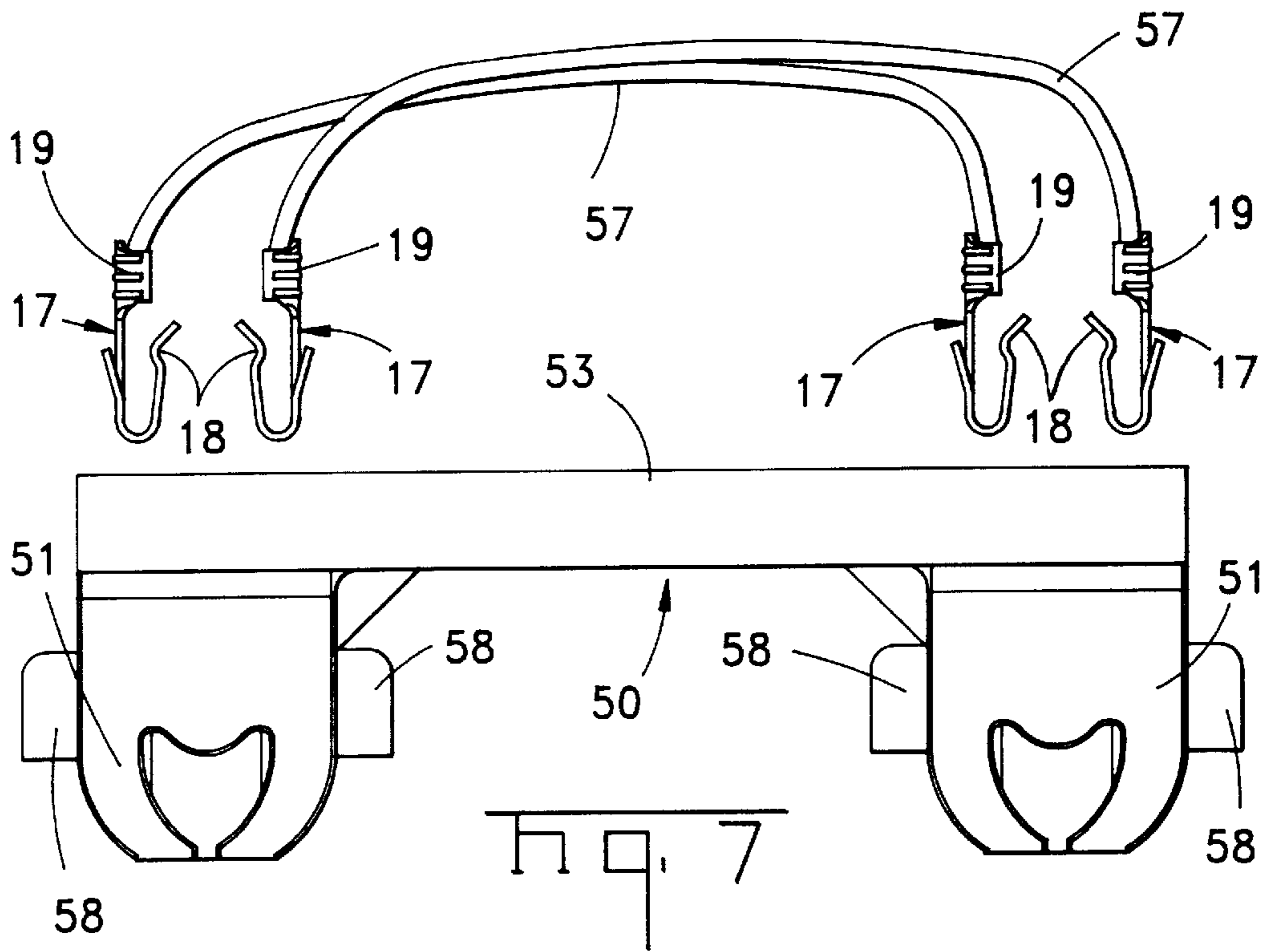
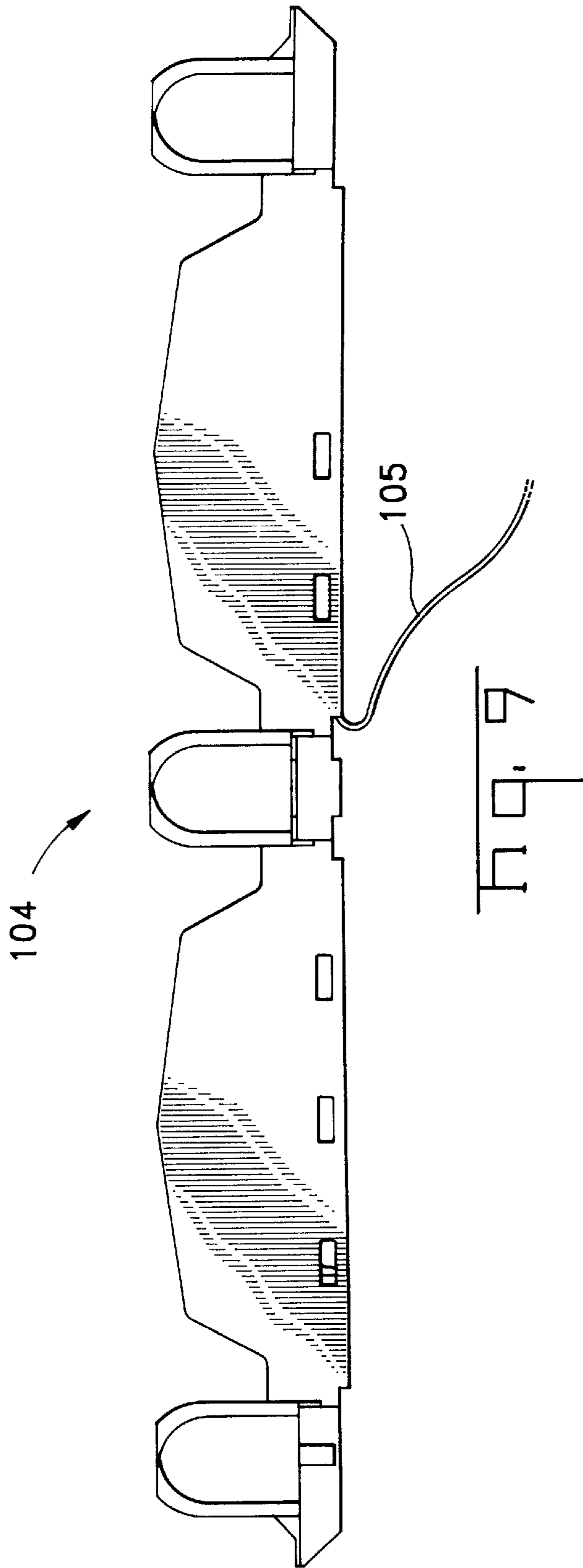

Fig. 6





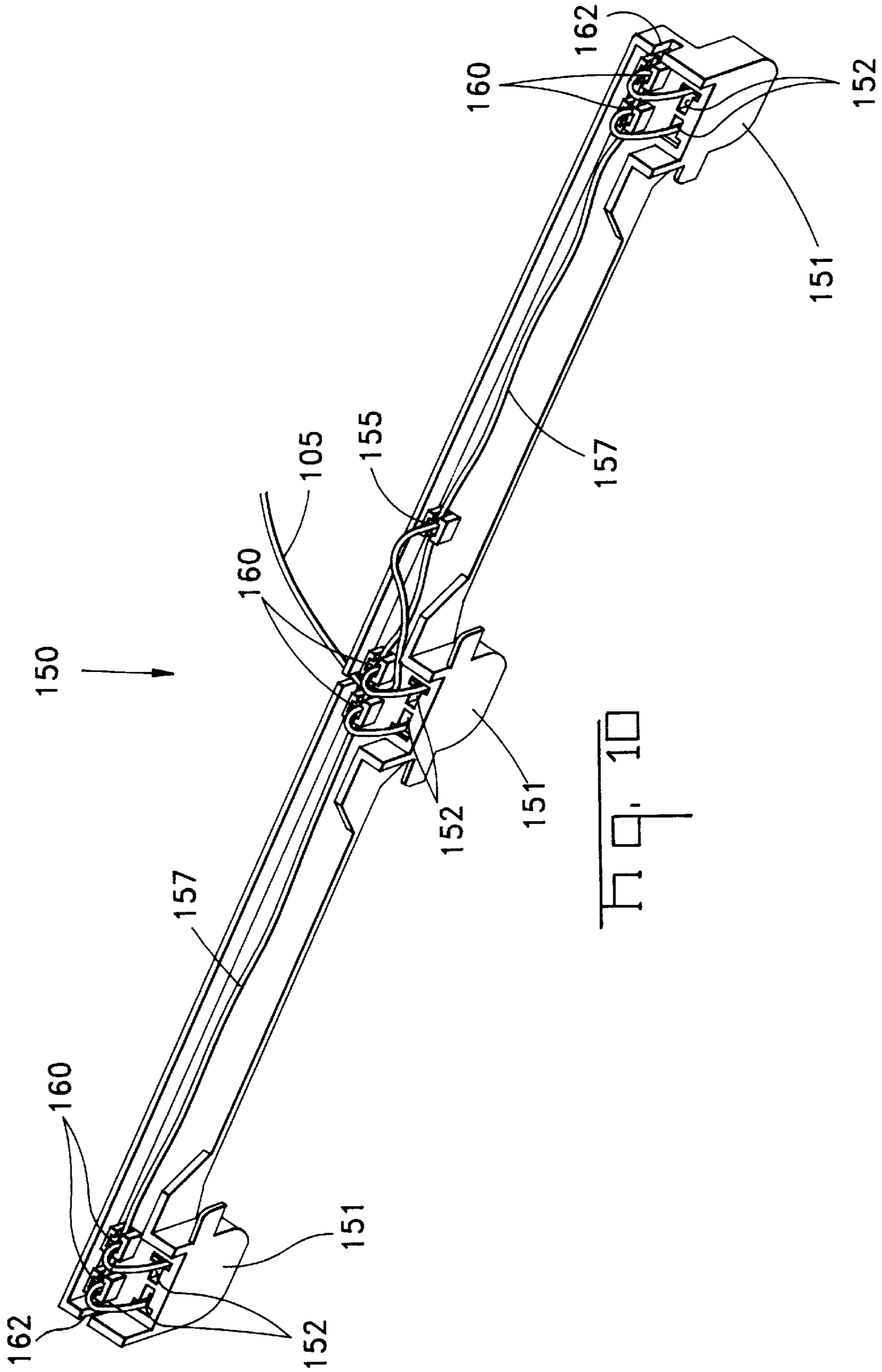

Fig. 10

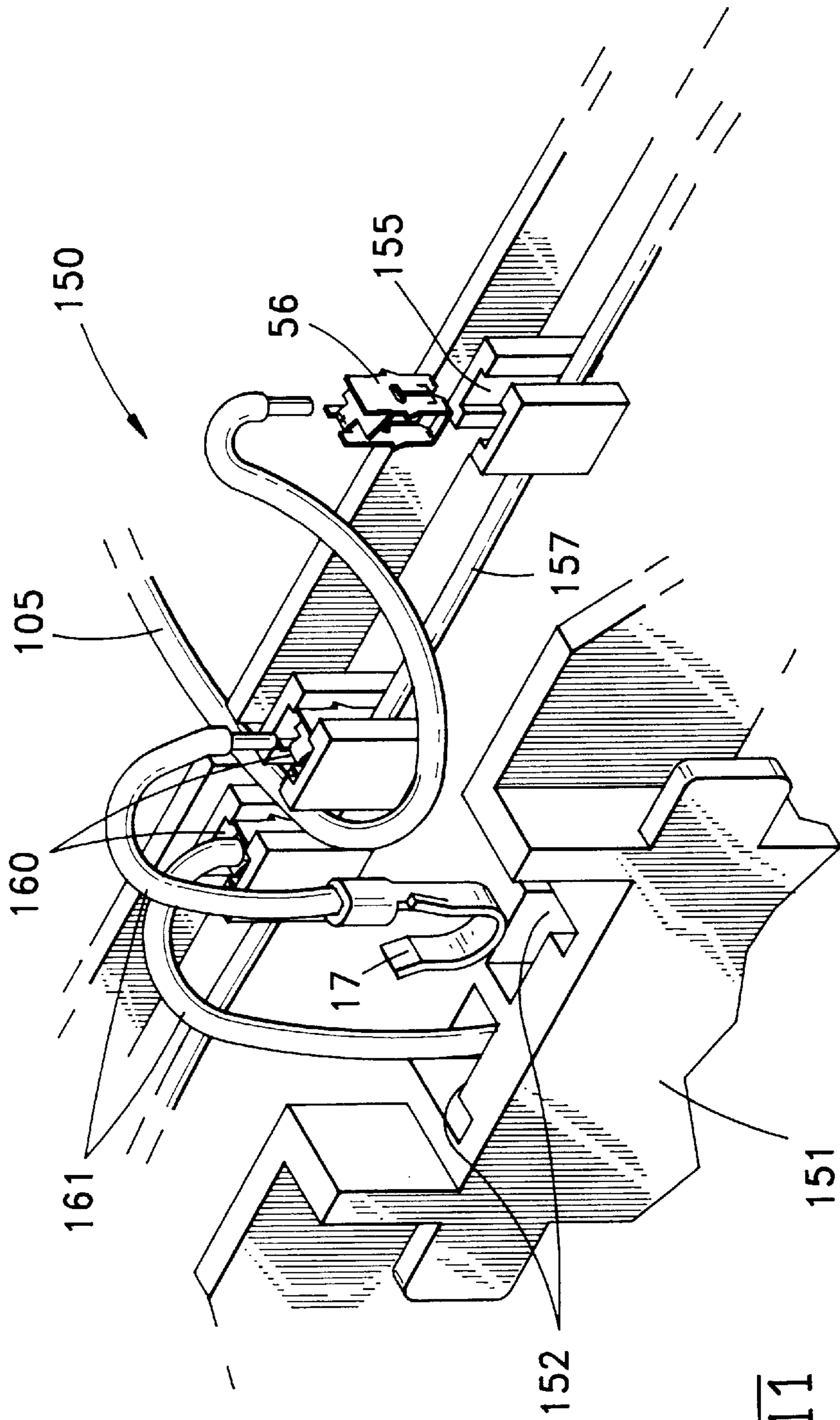

Fig. 11

LIGHTING ASSEMBLY FOR MULTIPLE FLUORESCENT LAMPS

CROSS-REFERENCE TO RELATED APPLICATIONS

This application is being filed concurrently with U.S. patent application Ser. No. 09/158,195, now U.S. Pat. No. 6,048,220, issued Apr. 11, 2000 both of which claim the benefit of U.S. Provisional Application No. 60/060,661, filed Oct. 2, 1997, and have the same assignee.

BACKGROUND OF THE INVENTION

1. Field of the Invention

This invention is related to lighting assemblies and is more particularly related to fluorescent lighting assemblies using electronic ballasts. More particularly, this invention is related to a fluorescent subassembly or lampholder including ballast components and integral fluorescent sockets.

2. Description of the Prior Art

Conventional ballasts used in overhead troffers or luminaires include lamps, ballasts and socket subassemblies or lampholders. The ballast or ballasts are mounted at the center of the troffer and attached to the top of the troffer. Wires extend from the ballast or ballasts to sockets located at opposite ends of the troffer. For a four lamp assembly, wires must be connected to sockets at both ends of the four lamps. When a defective ballast is replaced, often on a trial and error basis, these wires must be disconnected and reconnected. Installation and maintenance of conventional lighting assemblies is therefor time consuming and the manufacturing cost of the lighting assembly is increased.

One approach to simplifying and therefore reducing the cost of ballast installation is disclosed in U.S. Pat. No. 5,720,546 assigned to The Whitaker Corporation. This patent discloses an integral ballast that can be mounted at one end of a lighting assembly. A neutral wire is connected to the opposite end of the lighting assembly and this wiring must be completed during assembly of the lighting fixture. U.S. patent application Ser. No. 08/967,534 discloses a lighting assembly in which a ballast subassembly, including a ballast circuit similar to the MULTILITE MUL120 ballast circuit, can be mounted on a single end of a troffer with commoning contacts located at the opposite end. The ballast components are mounted on a printed circuit board positioned in a metal housing with conventional fluorescent sockets mounted on the exterior of the housing and connected to the printed circuit board.

U.S. Pat. No. 5,013,253 discloses another approach to simplifying the construction of fluorescent lighting fixtures. This patent discloses a method of wiring an otherwise conventional fluorescent lampholder in which wire leads are positioned in an insulating housing to connect terminals in integrally molded lamp sockets with an external connector block. Conventional external ballasts can then be wired to lamp sockets using this external connector block.

SUMMARY OF THE INVENTION

The principal objective of the instant invention is to simplify the assembly of fluorescent ballasts and of fluorescent lighting assemblies. By simplifying the manufacture of these assemblies they can be made more cost effective. The instant invention achieves these manufacturing improvements not only by changes to the assembly procedure, but by changes to the components themselves, which permit changes to the manufacturing procedure.

According to the invention, a fluorescent lighting assembly includes a ballast lampholder subassembly and at least one lampholder connector. The ballast lampholder and the at least one lampholder connector are located at respective opposite ends of the fluorescent lighting assembly with fluorescent lamps or tubes extending between. In a preferred embodiment, the ballast lampholder subassembly and the lampholder connector are mounted on a fluorescent lighting troffer. Each of the housings for both the ballast lampholder subassembly and the lampholder connector include a molded housing part. In a preferred embodiment, a plurality of lampholders comprise integrally molded extensions of this molded housing part, such as the cover for the ballast lampholder subassemblies. The lampholders include terminal cavities into which fluorescent lamp terminals can be inserted. Wires are crimped to these terminals before insertion into the terminal cavities, and these wires are then used either to attach the terminals to the ballast circuitry on the interior of the housing or to other terminals.

BRIEF DESCRIPTION OF THE DRAWINGS

The invention will now be described by way of example with reference to the accompanying drawings wherein:

FIG. 1 is an exploded view showing the basic components of a fluorescent lighting assembly that can be used with fluorescent lights in a fluorescent ceiling unit;

FIG. 2 is an exploded view showing the components of a ballast lampholder subassembly;

FIG. 3 is a side view of the housing of the ballast lampholder subassembly;

FIG. 4 is a section view of the housing shown in FIG. 3;

FIG. 5 is a bottom view showing the interior of the housing shown in FIG. 3;

FIG. 6 is a view showing an individual lampholder of the type which can be used on the ballast lampholder subassembly or on the lampholder connector subassembly;

FIG. 7 is a view of the components of a lampholder connector subassembly;

FIG. 8 is a bottom view of a lampholder connector subassembly;

FIG. 9 is a view of a three lamp ballast lampholder subassembly used in another embodiment of the invention;

FIG. 10 is a view of a three lamp lampholder connector used with the ballast lampholder subassembly shown in FIG. 9 to form a three lamp fluorescent lighting assembly; and

FIG. 11 is a view showing the manner in which fluorescent lamp terminals are attached to a bus wire in the embodiment of FIGS. 9 and 10.

DETAILED DESCRIPTION OF A PREFERRED EMBODIMENT

The fluorescent lighting assembly 2 as shown in FIG. 1 is intended to mount four conventional fluorescent lamps in a ceiling. This lighting assembly includes a ballast lampholder subassembly 4 located on a first end 38 of the lighting assembly, fluorescent lamps 30 extending between the first end 38 and the second end 40 of the lighting assembly 2, lampholder connectors 50 located at the second end 40 and a troffer 80 in which the other components are mounted. The preferred embodiment of this lighting assembly is of the type that could be mounted in a suspended ceiling in an office building. The lighting assembly 2 and the troffer 80 are shown in an inverted position in FIG. 1 so that the surface of the troffer, facing downward when installed, is

visible. This lighting assembly **2** can employ conventional fluorescent lamps **30**. In the preferred embodiment the lighting assembly **2** and the ballast lampholder subassembly **4** are of the type that would be used with instant start T-8 fluorescent lamps. The ballast subassembly **4** is an electronic ballast of the type that can energize two eight foot fluorescent lamps or four lamps that are each four feet in length as in this embodiment.

The components of the ballast lampholder subassembly **4** are shown in the exploded view of FIG. **2**. Ballast lampholder subassembly **4** is an integral unit or hub comprising a ballast housing **6** (FIG. **1**) that includes a housing cover **8** attached to a housing base **10** that encloses the electronic ballast circuitry and components on the interior of the housing **6**. The housing cover **8** is molded from a thermoplastic and the housing base **10** can be fabricated from sheet metal or plastic. In the preferred embodiment, the housing base **10** is a stamped metal plate that serves as a grounding member when connected to the metal troffer **80** (FIG. **1**).

The housing cover **8** is attached to the housing base **10** to form the housing **6** enclosing the fluorescent ballast. With reference also to FIG. **3**, the housing cover **8** has opposite sides **8a**, **8b** and top **8c** which enclose three sides of the housing **6**. The cover **8** extends between ends **8d** and **8e** (FIG. **2**) that would be adjacent to the opposite interior surfaces of a lighting assembly **2**. The housing base **10** encloses the fourth side of the housing **6**.

As shown in FIGS. **2** and **3**, ballast lampholder housing cover **8** includes three protruding housing areas **12** that provide room for the larger components in the power supply circuit and the ballast circuit of the electronic ballast. Four channels **14** are located on the top of the ballast subassembly **4** and extend between and on either side of the protruding housing areas or enclosures **12**. Channels **14** provide space for mounting fluorescent lamps **30** in fluorescent lampholders **15** that have a conventional mounting configuration. A fluorescent lamp lampholder **15** is located in each channel **14** to engage pins on the first base of a fluorescent lamp **30**. These lampholders **15** are integrally molded as part of the housing cover **8**.

With reference also to FIGS. **5** and **6**, each of the lampholders **15** has a pair of terminal cavities **16** in which fluorescent lamp terminals **17** are positioned. The lampholders **15** have a conventional lamp mounting configuration and are intended to receive one end of a bi-pin fluorescent lamp **30**. The terminal cavities **16** open onto an interior surface of the housing cover **8** so that the terminals can be inserted into the integrally molded lampholders **15**. The fluorescent lamp terminals **17** each include a terminal spring **18** and a crimp barrel **19** that attaches the terminal **17** to the stripped end of an insulated lead wire **20**. Terminal springs **18** of opposed terminals **17** face the center of the lampholder **15** and are deflected outwardly when a bi-pin lamp **30** is rolled into the lampholder **15**. In the preferred embodiment terminals **17** comprise stamped and formed terminals manufactured by AMP Incorporated as Part Number 640483.

As shown in FIG. **5**, the housing cover **8** also includes splicing terminal mounting pockets **23** molded on the interior of the cover **8**. A conventional insulation displacing splicing terminal can be inserted into each pocket **23** to splice wires spanning the pocket **23**. External power lead wires **26** can be spliced to wires extending from a printed circuit board **27**, shown in FIG. **2**, containing ballast circuitry and ballast components. The wires **26** are suitable for supplying external electrical power to the ballast subassembly. The splicing terminal in each pocket **23** comprises a

conventional terminal manufactured by AMP Incorporated as part number 62833-1 and the pocket **23** is configured to receive this terminal. The splicing terminal includes parallel insulation displacement slots each having parallel beams which engage the wires **26** to not only establish an electrical connection, but also to establish a redundant termination to the wire to provide an effective mechanical strain relief without additional components. Other leads (not shown) can be attached to a poke-in section of each splicing terminal and these leads are attached to other components in the ballast subassembly. In addition to other components of an electronic ballast, the printed circuit board **27** includes larger components such as output inductors **28** and a choke **29** as shown in FIG. **2**. These larger components are positioned on the printed circuit board **27** so that they can be mounted in the larger enclosure sections **12** between the lampholders **15**. As shown in FIG. **1**, the ballast lampholder subassembly **4** is mounted on only one end of the lighting assembly **2** and the troffer **80**.

Fluorescent lamps **30** are conventional tubular fluorescent lamps with a first bi-pin base **32** at one end and a second bi-pin base **34** at the opposite end. Two pins **36** at each end are conventional. Fluorescent lamps **30** are instant start lamps with a conventional instant start electrode (not shown) connected to the pins **36** at the ends of the glass envelope forming the lamp **30**. In the preferred embodiment the fluorescent lamps **30** are used with a suitable instant start electronic ballast circuit and power supply circuit such as that used in the MULTILITE MUL120 manufactured and sold by Electrofab, Ltd. The components of this ballast circuitry are included on printed circuit board **27**. The pins **36** fit within the lampholders **15** which are part of the ballast subassembly **4**. The lamps **30** can be rolled into position in the lampholders in a conventional manner. Since the preferred embodiment of this invention employs instant start fluorescent lamps, it should be understood that instant start fluorescent lamps having a single pin on each base could also be employed with suitable lampholders. This invention could also be employed with preheat fluorescent lamps and a suitable preheat electronic ballast.

In this invention, only the first base **32** of each fluorescent lamp **30** is connected directly to the electronic ballast in ballast lampholder subassembly **4**. The opposite second base **34** and the pins **36** therein are connected to lampholders in a lampholder connector **50**. The preferred embodiment of this invention is intended to be used with multiple fluorescent lamps **30**, and in the four lamp version of this invention, the fluorescent lamps are paired so that for each pair of fluorescent lamps, the respective first base **32** is attached to the ballast and the respective second bases **34** of the two lamps in each pair are electrically commoned in the lampholder connector **50**. In the preferred embodiment of FIGS. **1-8**, the pins **36** in the second base **34** of one lamp in each pair of lamps are connected to the corresponding pins **36** in the other lamp of that pair of lamps. For this invention, only the first bases **32** at the first end **38** of the lighting assembly will be energized to start the lamps. No current will flow through the pins **36** in the second bases **34** of the fluorescent lamp pairs until an arc is established between the opposite ends of each lamp **30**. By using an electronic ballast, such as the MULTILITE MUL120 manufactured and sold by Electrofab, Ltd., that is capable of operating fluorescent lamps of twice the length of the lamps **30**, it then becomes possible to common the second bases **34** through one of the lampholder connectors **50**. The electronic ballast used in ballast subassembly **4** is also capable of operating two separate pairs of fluorescent lamps, so the preferred embodiment employs two pairs or four lamps **30**.

With reference to FIGS. 9 and 10, ballast lampholder subassembly 104 and lampholder connector 150 are three lamp versions of the lampholder subassembly 4 and lampholder connector 50, respectively. The ballast lampholder subassemblies 4, 104 and the lampholder connectors 50, 150 are fabricated and assembled so that the cost of the fluorescent lighting subassembly can be significantly reduced. By molding the lampholder cover 8 and the corresponding cover for the three lamp version 104 with integrally molded lampholders 15, the cover can be used to simplify assembly. This is best appreciated by referring to FIG. 2. The fluorescent lamp terminals 17 can be crimped to wires 20 and inserted into the lampholders 15 with the wires extending downward from the cover 8. Opposite ends of these wires 20 can then be attached to the printed circuit board 27 either by soldering or by inserting terminals crimped to the wire ends onto pins soldered to the printed circuit board. For example, a receptacle, such as AMP Incorporated part number 61291, can be crimped to the end of each wire 20, and it can be mated to a pin, such as AMP Incorporated part number 61137, previously soldered to the printed circuit board 27. This approach simplifies hand wiring of the fluorescent lamp terminals to the ballast circuitry on the printed circuit board. Next, the printed circuit board can be positioned on the interior surface of the housing base 10. If the housing base 10 comprises a stamped metal plate, the ballast circuit can be grounded to this base, which can in turn be attached by screws or other fasteners to the metal troffer 80 (FIG. 1) when the ballast lampholder subassembly 4 is placed in service. Power wires 26 are attached to the ballast circuitry by using a splicing terminal in a pocket 23 in the manner which was discussed previously with reference to FIG. 5. After the internal components have been assembled in this manner, the housing base 10 can be snapped to the housing cover 8 to complete the assembly of the ballast lampholder subassembly 4.

The integral ballast lampholder subassembly 4 and the lampholder 50 can be mounted on troffer 80 as shown in FIG. 1. Troffer 80 is generally conventional in construction having a top wall 82, two end walls 84 at the first and second ends of the lighting assembly and two side walls. Since the ballast lampholder subassembly 4 is mounted at an end of the troffer 80, the four fluorescent lamps 30 can be mounted in the troffer on substantially equally spaced centerlines without the need for additional space between the two center fluorescent lamps to accommodate a conventional ballast.

With reference to FIGS. 1, 7 and 8, the lampholder connector subassemblies 50 which are located at the opposite end of the troffer 80 include a molded housing with connector lampholders 51 molded to the housing in much the same manner as for the ballast lampholder subassembly 4. Fluorescent lamp terminals 17 as previously described are inserted into the lampholders 51. However, the terminals in the lampholder connector subassembly need not be connected to the ballast. These fluorescent lamp terminals 17 merely connect corresponding pins of multiple fluorescent lamps 30. Therefore these fluorescent lamp terminals 17 can be joined by wires 57 extending between two terminals in different connector lampholders 51. Each wire 57 joins two corresponding terminals 17 in two lampholders 51. In the embodiment shown, two connector lampholders 51 are located at opposite ends of a connector base 53. Terminal cavities 52 in each connector lampholder 51 open onto an open lower surface or trough 54 of the connector housing. The wire leads 57 extending between two spaced-apart lampholders 51 are disposed in this trough 54 on the underside of the lampholder base 53. The wire leads 57 are

held in the trough 54 by molded-in raised nubs that keep the wire leads tucked into the troughs 54 for wire management and to prevent the wire leads 57 from dangling out of the troughs 54. The same basic approach shown for the two-lamp lampholder connector 50 can be used for a four-lamp lampholder. For both the two-lamp and four-lamp versions the same terminal subassembly comprising two fluorescent lamp terminals 17 connected by a wire lead 57 could be used, because the length of the wire lead 57 would be the same.

Lampholder connectors 50 also include mounting tabs 58 extending from opposite sides of the lampholders 51. These tabs 58 can be inserted into slots (not shown) on the end walls 84 of the troffer 80 to mount the lampholder connectors 50 with connector lampholders 51 in alignment with the lampholders 15 on the ballast lampholder subassembly 4 at the opposite end of the lighting fixture assembly 2. The two dual position lampholder connectors 50 shown in FIGS. 1 and 7 do not need to be connected to the ballast circuitry in the ballast lampholder subassembly 4 because the electronic ballast circuit used in this embodiment can be used to initiate and power two four foot lamps 30. One of the dual lampholder connectors 50 connects the opposite ends of two side-by-side fluorescent lamps 30.

A second embodiment of this invention is shown in FIGS. 9 and 10. This embodiment uses a three-lamp ballast lampholder subassembly 104 and a three-lamp lampholder connector 150. The three-lamp ballast lampholder subassembly 104 includes a ballast circuit for use in a three-lamp lighting fixture, but in most other respects is constructed in the same manner as the four-lamp version. The principal difference is that the three-lamp ballast lampholder subassembly 104 includes a wire 105 that connects the three-lamp ballast lampholder subassembly 104 to the three-lamp lampholder connector 150 located at the opposite end of the fluorescent lamps in a three-lamp lighting fixture. This wire 105 is connected to the ballast lampholder subassembly 104 in substantially the same manner as to the lampholder connector 150, and attachment of this wire will be discussed with reference to the lampholder connector 150. The three-lamp lighting fixture thus can operate in much the same manner as that described in U.S. Pat. No. 5,720,546 which is incorporated herein by reference.

As shown in FIG. 10, lampholder connector 150 includes three lampholders 151 with two terminal cavities 152 in each lampholder 151. The same terminals 17 are used in this three-lamp lampholder connector 150. The lampholder connector 150 also includes two pockets 160 located adjacent to the terminal cavities 152 in each lampholder. In addition to the six pockets 160, a seventh pocket 155 is located adjacent to the central lampholder. Each of these molded pockets is configured to receive a splicing terminal 56, shown in FIG. 11, which in a preferred embodiment comprises a conventional terminal manufactured by AMP Incorporated as part number 62833-1. As shown in FIG. 10, a single bus wire 157 extends between opposite ends of the three-lamp lampholder 150, and this single bus wire 157 extends through all of the pockets 155 and 160. Each pocket includes slots on either side so that the bus wire 157 can be laced through the slots so as to span the corresponding pockets 155 and 160. After the bus wire 157 has been inserted into each of the pockets, a splicing terminal 56 is inserted into each pocket. Each splicing terminal 56 includes two insulation displacement slots defined by opposed metal edges which engage the bus wire 157 to form a gas tight permanent electrical connection to the bus wire 157 in a conventional manner. In addition to the insulation displacement slots, each splicing terminal 56

also includes a poke-in terminal portion which can engage the stripped end of a wire when the stripped end is inserted into the poke-in terminal portion. Alternatively, a spade terminal may be attached to the stripped end of the wire and inserted into the poke-in terminal portion.

The poke-in terminal portion of each splicing terminal **56** is accessible through the open end of its corresponding pocket **160**. As shown in FIG. **11**, fluorescent lamp terminals **17** located in the cavities **152** are each connected to the common bus wire **157** by a respective lead wire **161**. The stripped end of each lead wire **161** is inserted into the poke-in terminal portion of a corresponding splicing terminal **56** located in a pocket **160** adjacent to a corresponding lampholder cavity **152**. All of the fluorescent lamp terminals **17** in the three-lamp lampholder connector **150** are thus electrically connected to the single bus wire **157**. Therefore, all of the fluorescent lamp terminals **17** in the three-lamp lampholder connector **150** are electrically connected to each other.

The splicing terminal **56** in the seventh pocket **155**, which is also connected to the single bus wire **157**, is used to connect all of the fluorescent lamp terminals **17** in the three lampholders **151** to the ballast subassembly **104** located at the opposite end of the troffer in a three-lamp lighting assembly. A stripped end of wire **105** is inserted into the poke-in terminal portion of the splicing terminal **56** in the pocket **155**, and in this manner the wire **105**, extending the length of the lighting assembly, is connected to the bus wire **157** in the three-lamp lampholder connector **150**. The opposite end of the wire **105** can be connected to the ballast in the ballast subassembly **104** by using a similar splicing terminal **56**, not shown.

Each three-lamp lampholder connector **150** also includes slots **162** on opposite ends. These slots permit the bus wire **157** to extend beyond the ends of the lampholder connector **150**. These slots **162** are aligned with the bus wire **157** and facilitate efficient assembly of the three-lamp lampholder connector **150**. A series of three-lamp lampholder connector housings can be positioned end to end with slots **162** in alignment. A continuous wire can then be laced through troughs on the bottoms of the housings with the continuous wire extending through the slots **162**. A portion of the wire extending between each pair of adjacent housings can be cut, thereby severing the wire connection between the adjacent housings. In this way, separate lampholder connectors can be wired in an efficient manner.

The three-lamp version of this lighting assembly shown in FIGS. **9-11** differs from the two or four-lamp version because all of the fluorescent lamp terminals **17** in the three-lamp version of the lampholder connector **150** are electrically connected. Therefore, two terminals **17** connected to two pins in the same fluorescent lamp are electrically commoned in the three lamp version. For the two-lamp lampholder connector **50** of FIGS. **7** and **8**, the terminals **17** which are connected to the same lamp are not electrically commoned. Instead, each fluorescent lamp terminal **17** in one lampholder **51** of the lampholder connector **50** is connected to corresponding terminals **17** having the same relative position in the other lampholder **51**. In other words, terminals on the right side of each lampholder are electrically connected together and terminals on the left side of each lampholder are electrically connected together, but right-side terminals are not electrically connected to left-side terminals. It should be understood, however, that all of the terminals **17** for the two-lamp version **50** could be connected to a single bus in the same manner as for the three-lamp lampholder connector **150** because the ballast need not be

connected directly to an individual pin on lamps connected to the lampholder connectors.

The use of integrally molded lampholders **51** simplifies the assembly of the lampholder connectors **50** which are assembled in much the same manner as the lampholder connectors **150**. Terminals **17** previously connected to wires can be inserted into lampholder terminal cavities on the lower surface **53** in the same manner as for the ballast lampholder cover **8**. The use of splicing terminals with the three-lamp lampholder connector **150** has been previously discussed.

Although the use of integrally molded lampholders greatly simplifies assembly of both the ballast lampholder subassemblies and the lampholder connectors, it should be understood that some, though not all, of this improvement can be achieved by attaching separately molded lampholders to a molded cover or to the lampholder connector base. Although this variation adds an assembly step, it still uses the same basic approach to achieve the other advantages of this invention. This is but one of the minor changes that can be resorted to without departing from the scope of the invention defined by the following claims.

We claim:

1. A lighting assembly for use in mounting a plurality of fluorescent lamps comprising:

a ballast lampholder subassembly located at a first end of the lighting assembly, including a ballast lampholder housing with ballast circuitry mounted within the ballast lampholder housing connected to terminals in lampholders extending from the housing;

at least one lampholder connector mounted on a second end of the lighting assembly, the lampholder connector including spaced-apart lampholders extending from a lampholder connector base with lampholder terminals in at least two of the lampholders being connected by lead wires extending through the lampholder connector base;

wherein the lampholders of the ballast lampholder subassembly and the lampholder connector comprise integrally molded extensions of the ballast lampholder housing and the lampholder connector base, respectively.

2. The lighting assembly of claim **1** wherein the ballast lampholder housing comprises a molded cover attached to a ballast lampholder base, and the lampholders of the ballast lampholder housing comprise molded extensions of the molded cover.

3. The lighting assembly of claim **2** wherein the lampholders of the ballast lampholder housing include terminal cavities which open to an interior of the housing so that the terminals can be inserted into the lampholders through the openings.

4. The lighting assembly of claim **2** wherein the ballast lampholder base comprises a metal plate attached to the ballast lampholder housing cover.

5. The lighting assembly of claim **4** wherein the ballast circuitry is mounted on a circuit board positioned on the ballast lampholder base.

6. The lighting assembly of claim **5** further comprising lead wires electrically connecting the terminals to the circuit board.

7. The lighting assembly of claim **2** wherein the molded cover includes protruding sections separated by channels, and the lampholders are located in the channels.

8. The lighting assembly of claim **1** wherein the lampholders of the lampholder connector include terminal cavi-

ties which are open to a lower surface of the lampholder connector base, the terminals are disposed in the cavities, and the terminals are connected by lead wires which extend along the lower surface of the lampholder connector base.

9. The lighting assembly of claim 1 wherein the ballast lampholder subassembly and the lampholder connector are mounted at opposite ends of a fluorescent lighting troffer.

10. The lighting assembly of claim 9 wherein the ballast lampholder subassembly and the lampholder connector are separate with each attached only to the fluorescent lighting troffer and to fluorescent lamps extending therebetween.

11. A ballast lampholder subassembly for use in a fluorescent lighting fixture comprising:

a molded ballast lampholder cover with lampholders extending from the ballast lampholder cover, each of the lampholders including a pair of terminal cavities opening to an interior surface of the ballast lampholder cover;

fluorescent lamp terminals insertable into the terminal cavities after first ends of wire leads have been terminated to the fluorescent lamp terminals;

a circuit board with ballast circuitry and ballast components mounted on the circuit board, second ends of the wire leads being attached to the circuit board; and

a ballast lampholder base attached to the ballast lampholder cover to form a ballast lampholder housing, the circuit board and the wire leads which connect the fluorescent lamp terminals to the ballast circuitry and to the ballast components being positioned within the ballast lampholder housing.

12. The ballast lampholder subassembly of claim 11 wherein the lampholders comprise molded extensions of the molded ballast lampholder cover.

13. The ballast lampholder subassembly of claim 12 wherein the molded ballast lampholder cover encloses three sides of the ballast lampholder housing and the ballast lampholder base encloses a fourth side of the ballast lampholder housing.

14. The ballast lampholder subassembly of claim 13 wherein the ballast lampholder base comprises a metal plate.

15. The ballast lampholder subassembly of claim 14 wherein the ballast lampholder cover is snapped to the metal plate.

16. The ballast lampholder subassembly of claim 14 wherein the circuit board is mounted on an interior surface of the ballast lampholder base.

17. The ballast lampholder subassembly of claim 13 wherein the molded ballast lampholder cover includes multiple enclosure sections separated by channels having a smaller volume than the enclosure sections, the molded lampholders extending from the channels with the enclosure sections providing space for housing ballast components.

18. The ballast lampholder subassembly of claim 17 wherein the lampholders are equally spaced-apart between opposite ends of the ballast lampholder housing.

19. The ballast lampholder subassembly of claim 17 wherein the ballast lampholder cover includes a mounting pocket for supporting a splicing terminal for connecting power leads to the printed circuit board.

20. A method of assembling a ballast subassembly for use in a lighting fixture comprising the steps of:

terminating insulated wire leads to terminals;

inserting the terminals into lampholders molded as part of a ballast lampholder housing cover with the insulated wire leads extending from the terminals;

connecting opposite ends of the wire leads to a circuit board containing ballast circuitry and ballast components;

positioning the circuit board between a ballast lampholder housing base and the ballast lampholder housing cover; and

attaching the ballast lampholder housing base to the ballast lampholder housing cover to form a ballast lampholder housing which encloses the circuit board and the wire leads.

* * * * *