



US006213881B1

(12) **United States Patent**  
**Sasa et al.**

(10) **Patent No.:** **US 6,213,881 B1**  
(45) **Date of Patent:** **Apr. 10, 2001**

(54) **DAMPER DEVICE**

(75) Inventors: **Hirozumi Sasa; Kenji Takahashi**, both of Tokyo (JP)

(73) Assignee: **Tok Bearing Co., Ltd.**, Tokyo (JP)

(\*) Notice: Subject to any disclaimer, the term of this patent is extended or adjusted under 35 U.S.C. 154(b) by 0 days.

(21) Appl. No.: **09/212,516**

(22) Filed: **Dec. 16, 1998**

(30) **Foreign Application Priority Data**

Dec. 16, 1997 (JP) ..... 9-363506

(51) **Int. Cl.**<sup>7</sup> ..... **F16D 57/02**; F16F 9/14

(52) **U.S. Cl.** ..... **464/24**; 188/296; 188/308; 16/50

(58) **Field of Search** ..... 464/1, 2, 25, 24, 464/180, 164, 28; 16/54, 50; 188/296, 290, 293, 294, 306, 307, 308

(56) **References Cited**

**U.S. PATENT DOCUMENTS**

4,653,141 \* 3/1987 Converse ..... 188/306

4,825,503 \* 5/1989 Shiramasa et al. .... 16/52  
5,664,286 \* 9/1997 Sorimachi ..... 16/54  
5,720,370 \* 2/1998 Takahashi ..... 188/306  
5,988,329 \* 11/1999 Evans, Jr. et al. .... 188/296

**FOREIGN PATENT DOCUMENTS**

07229531 8/1995 (JP) .  
07293624 11/1995 (JP) .

\* cited by examiner

*Primary Examiner*—Terry Lee Melius  
*Assistant Examiner*—Kenneth Thompson

(57) **ABSTRACT**

A damper device includes a casing, a rotor partly housed in the casing, a viscous fluid filled in the casing around the rotor, and a torque generator for generating a torque during a rotating stroke of the rotor. The torque generator includes a fluid torque adjuster for producing a relatively large torque in at least a terminal range of the rotating strokes in normal and reverse directions of the rotor.

**13 Claims, 12 Drawing Sheets**

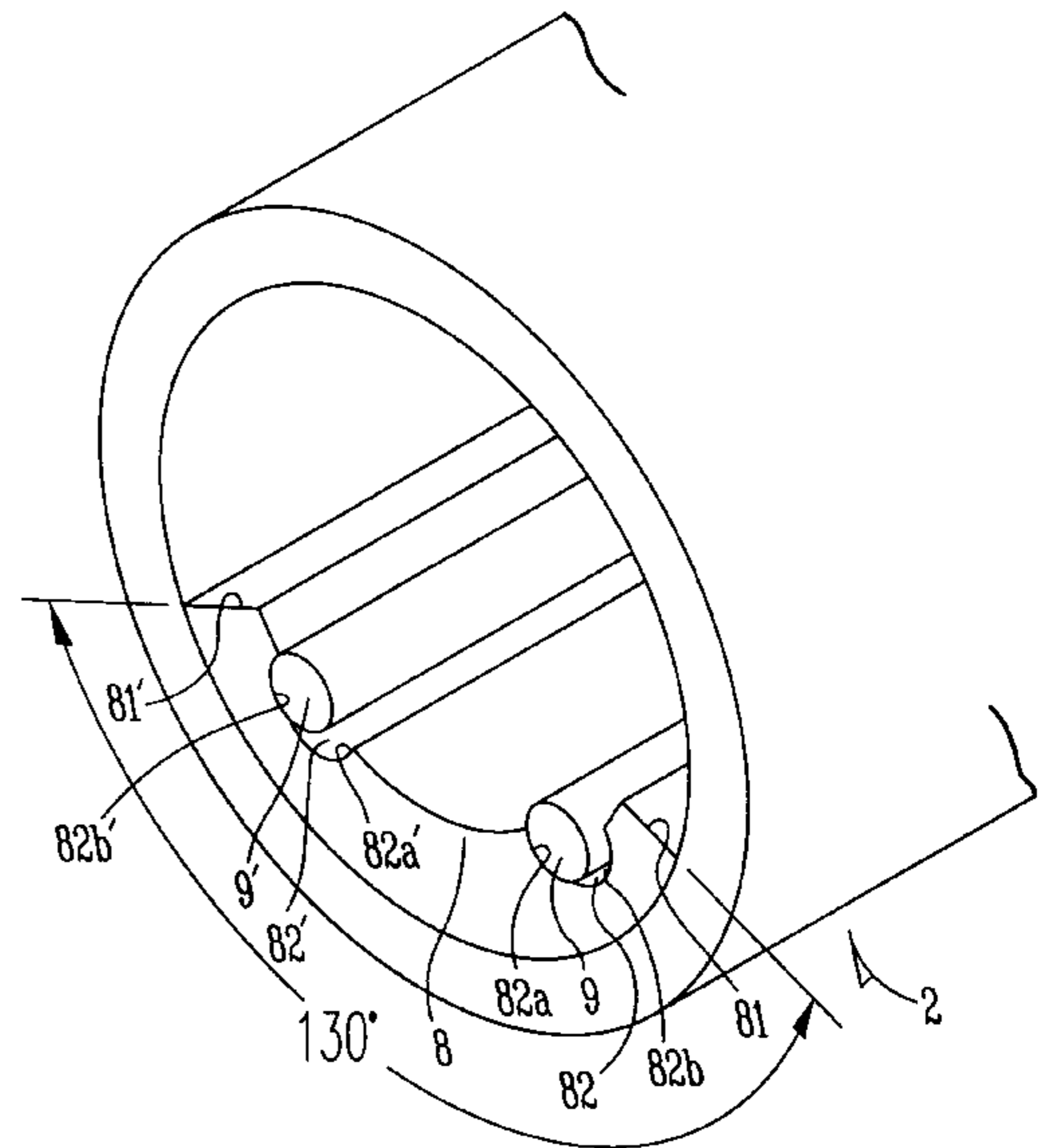
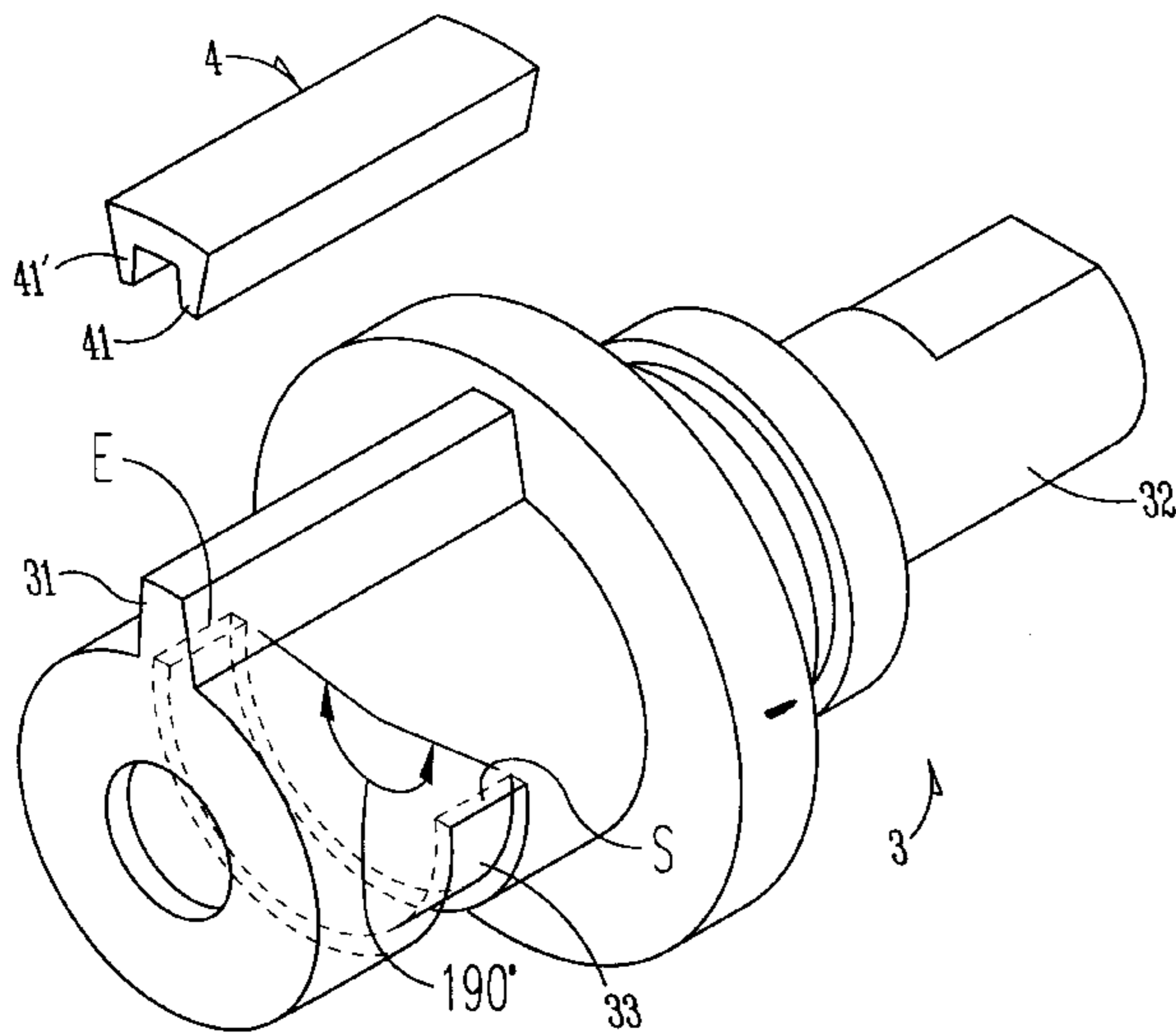

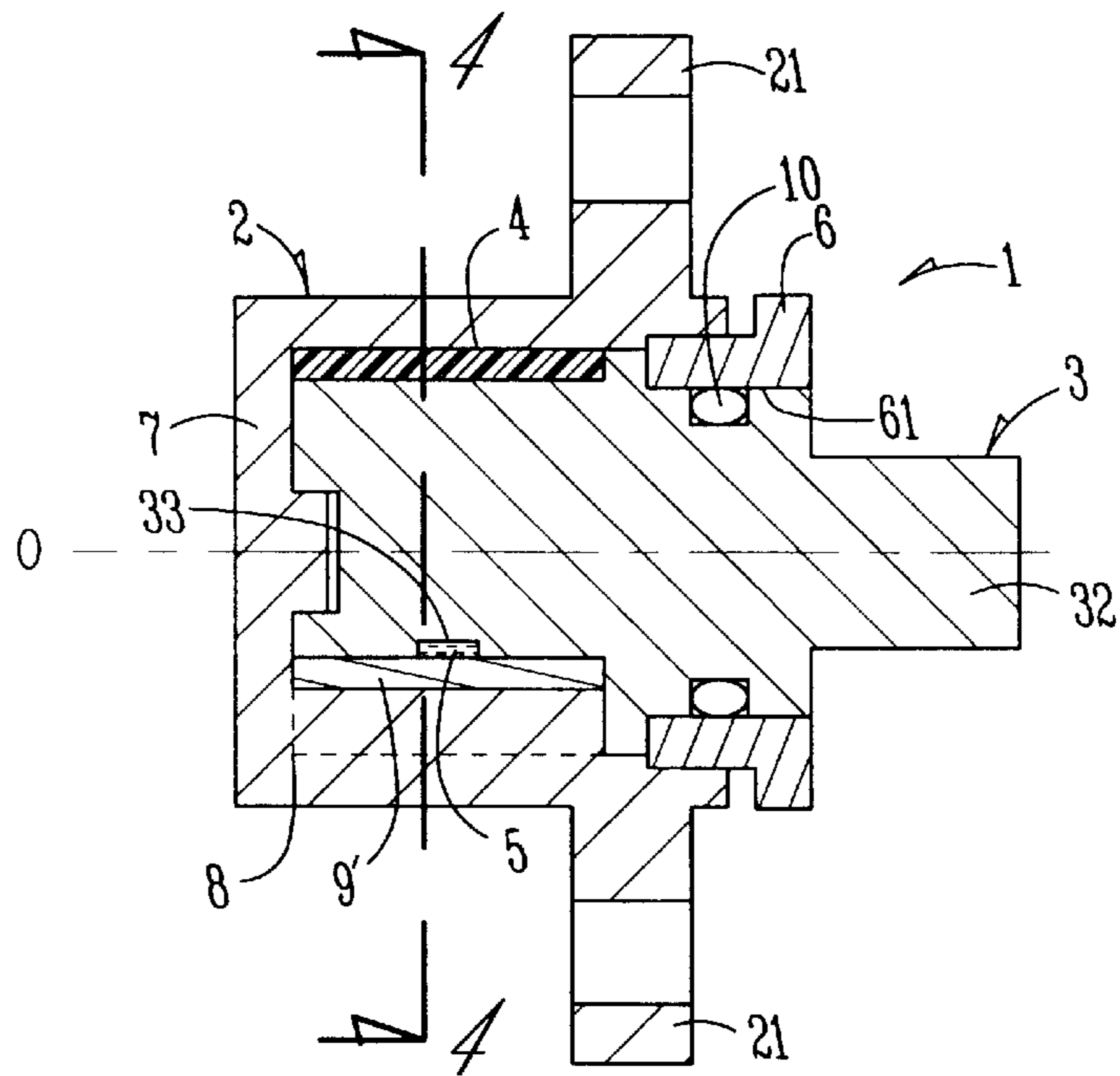

Fig. 1

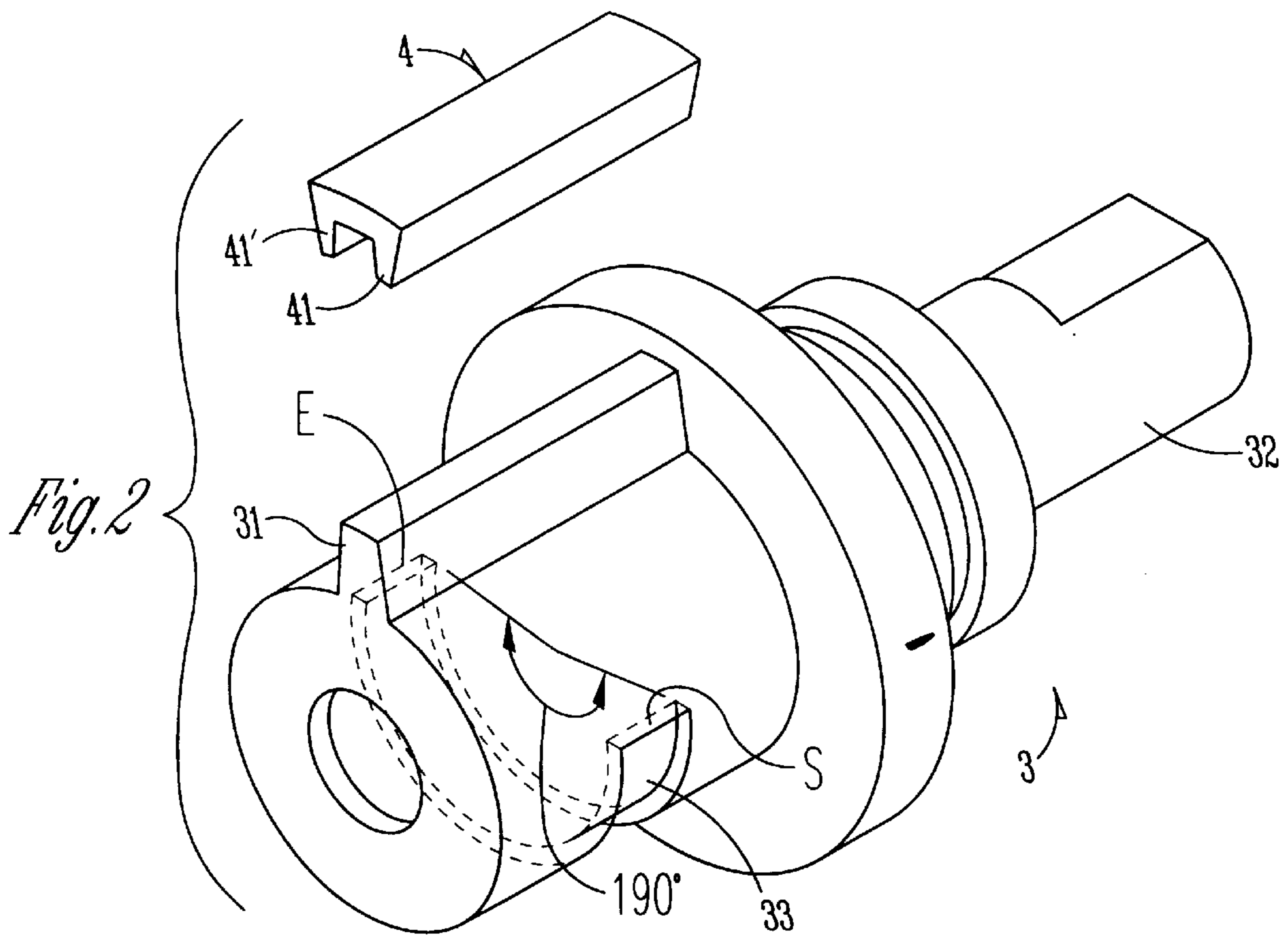
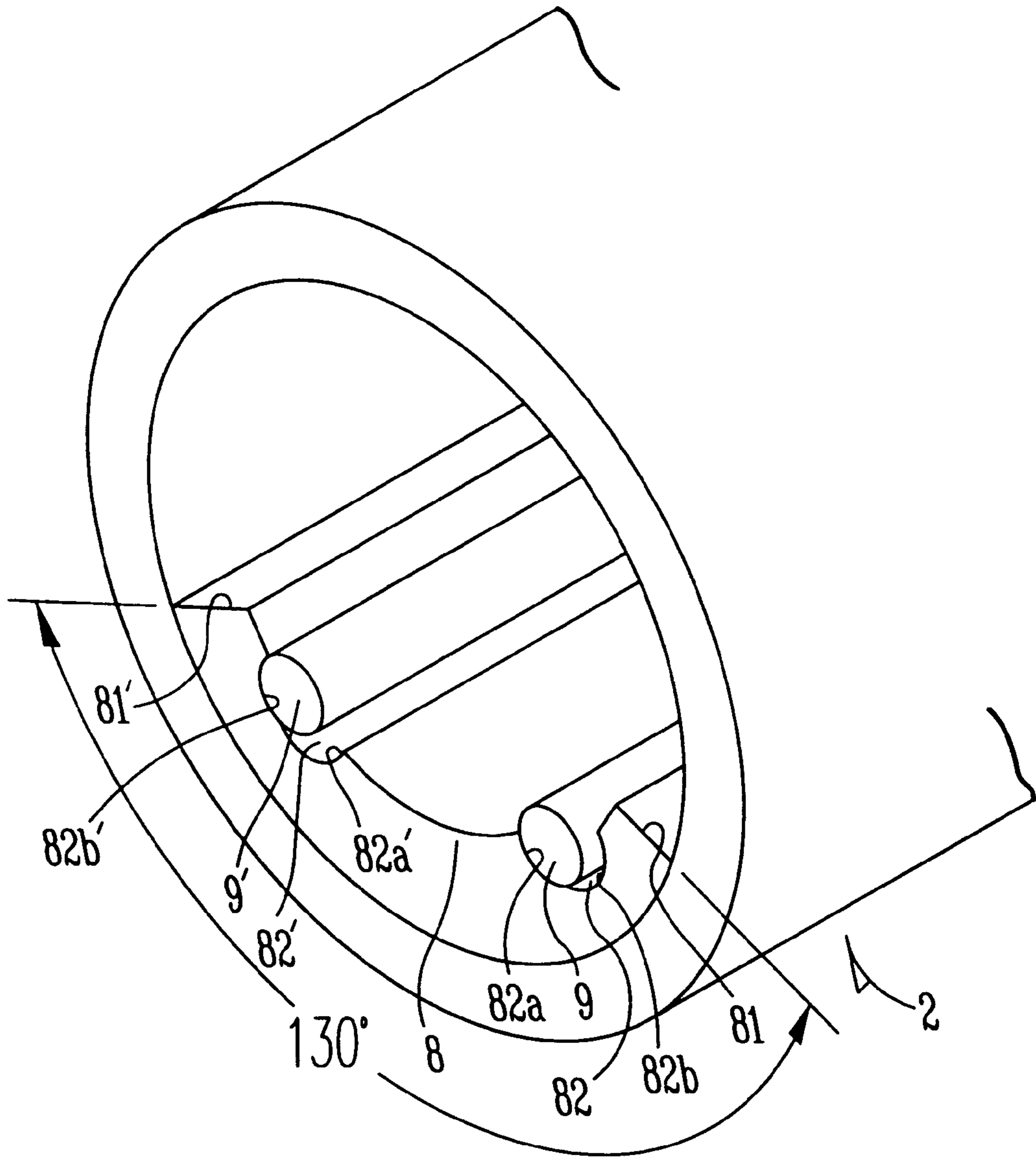
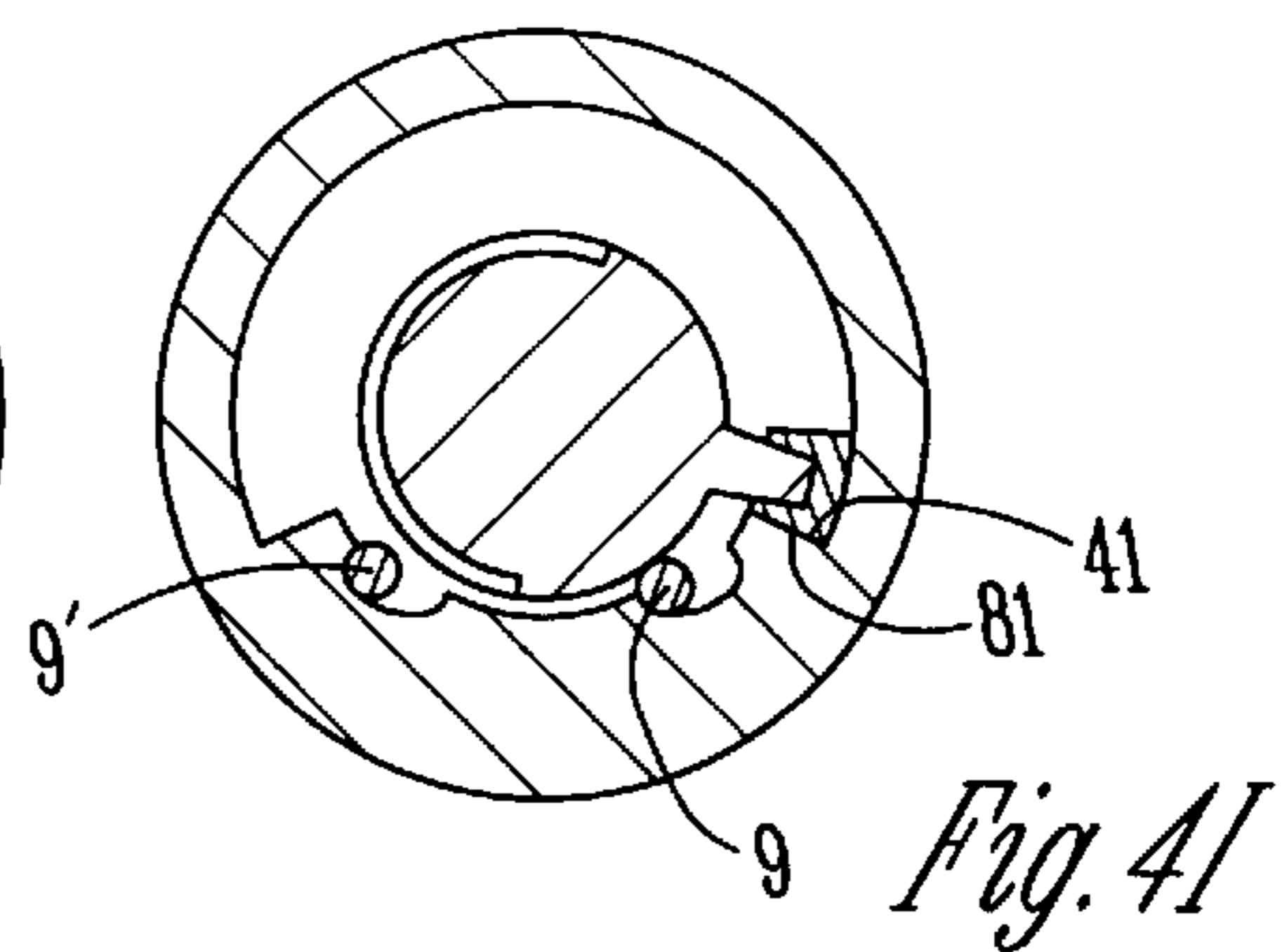
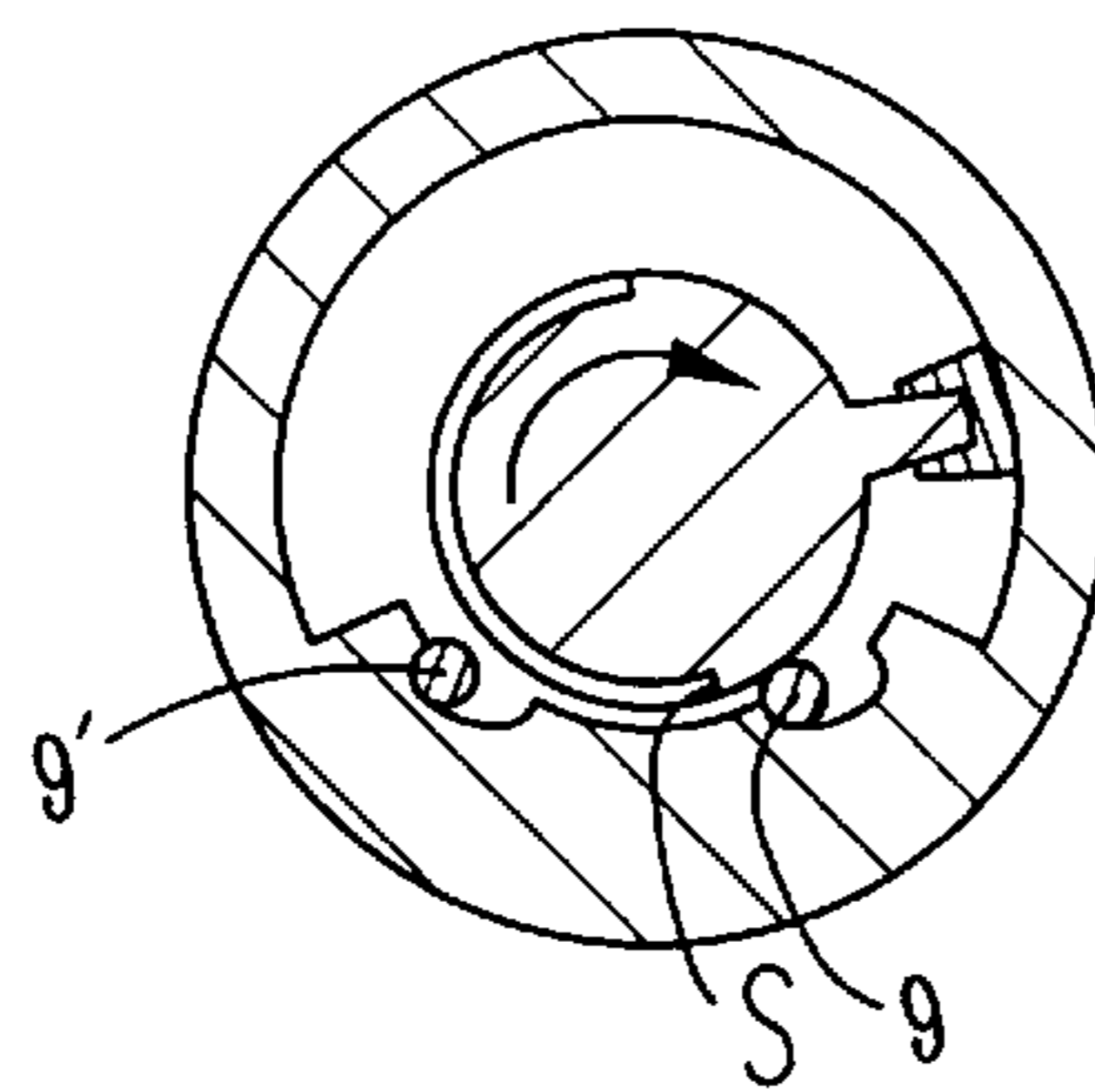
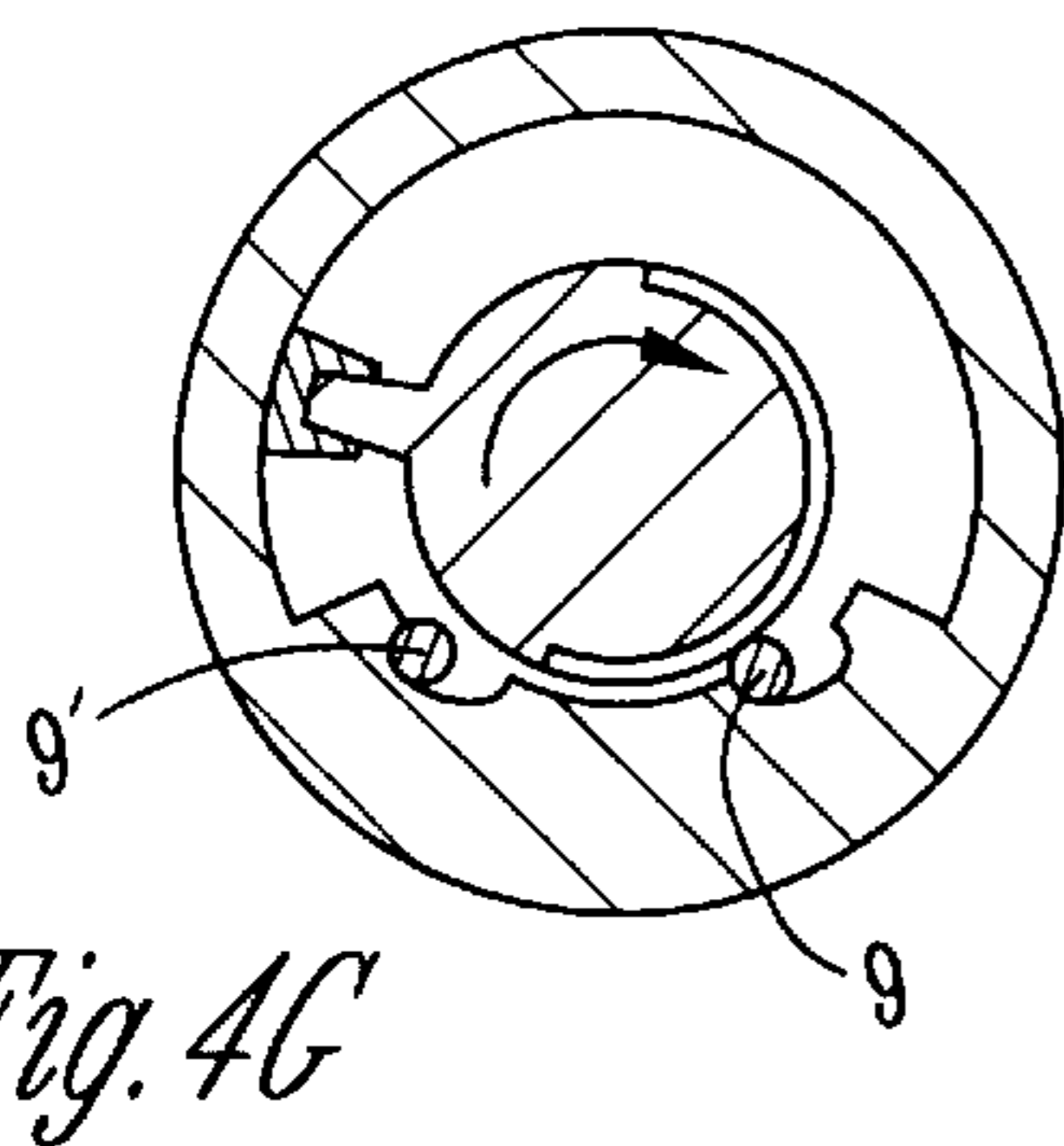
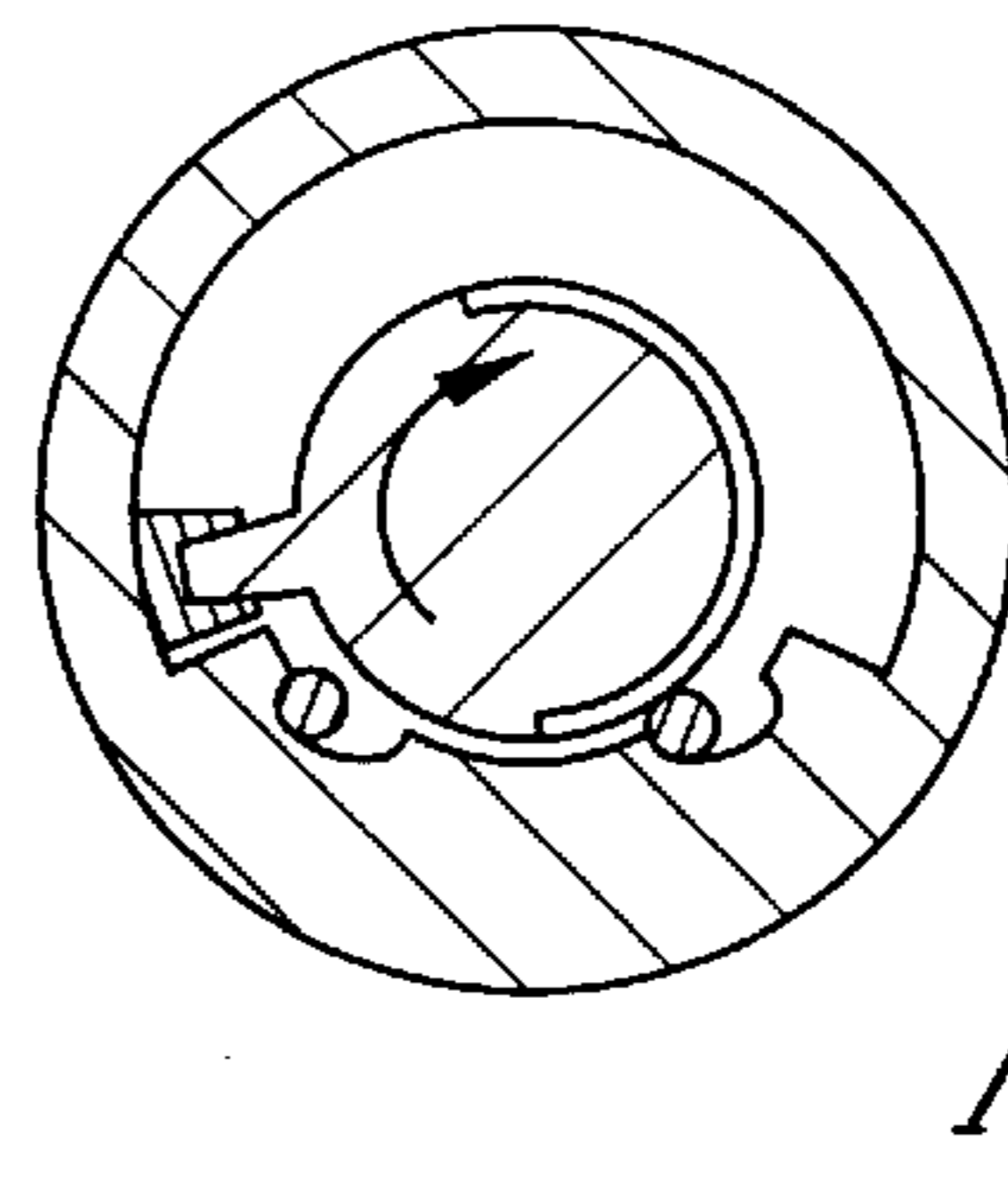
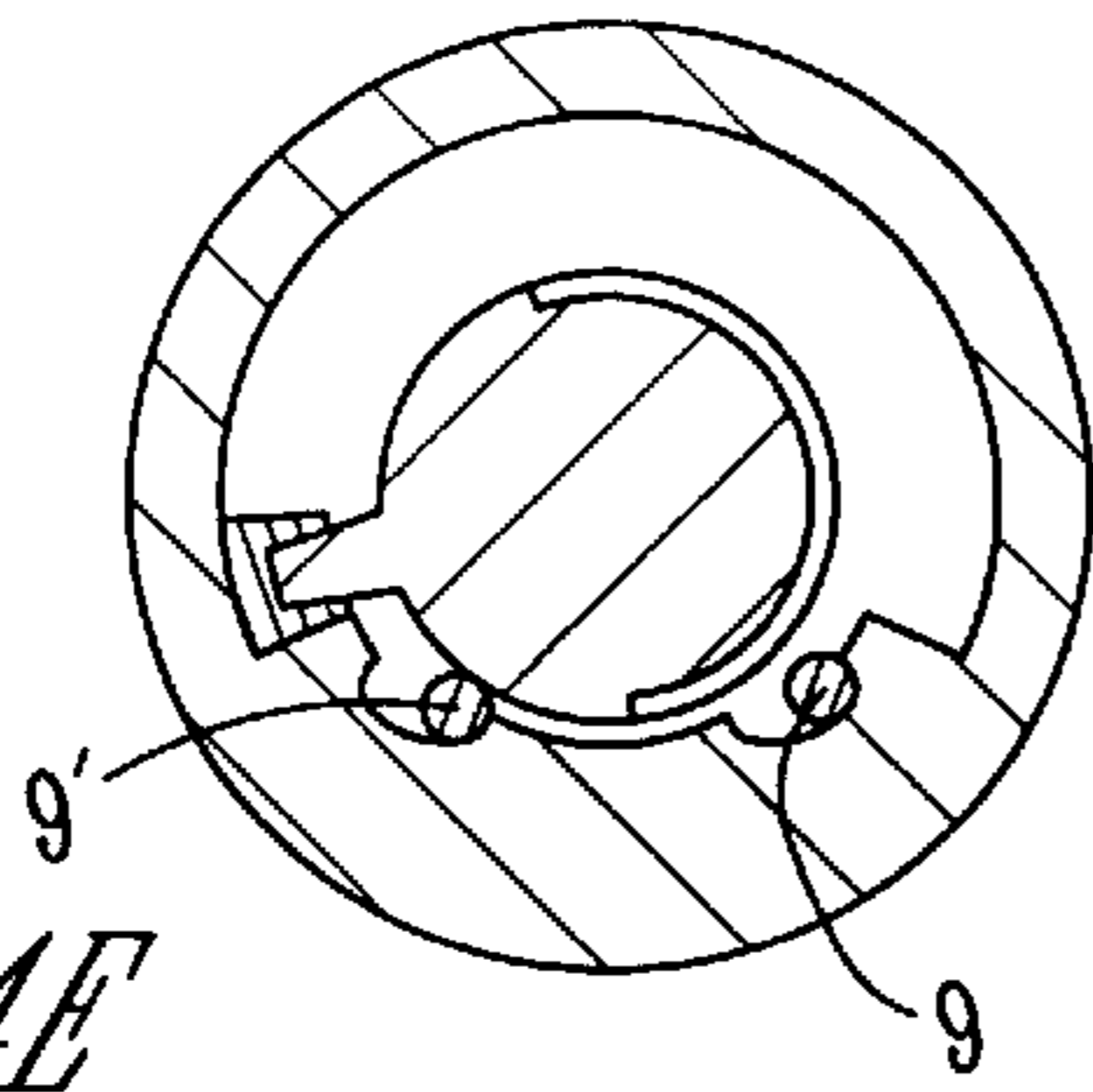
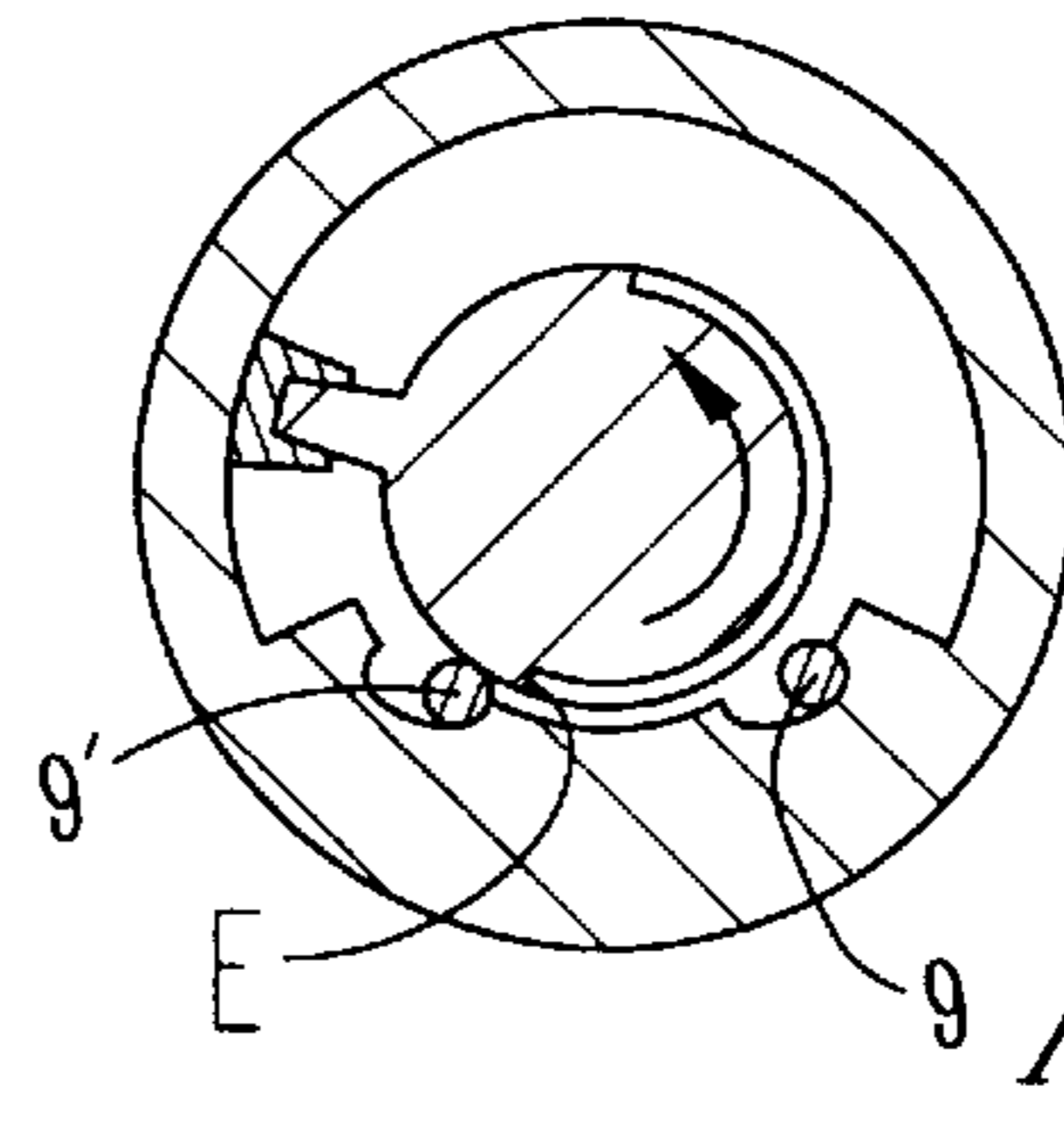
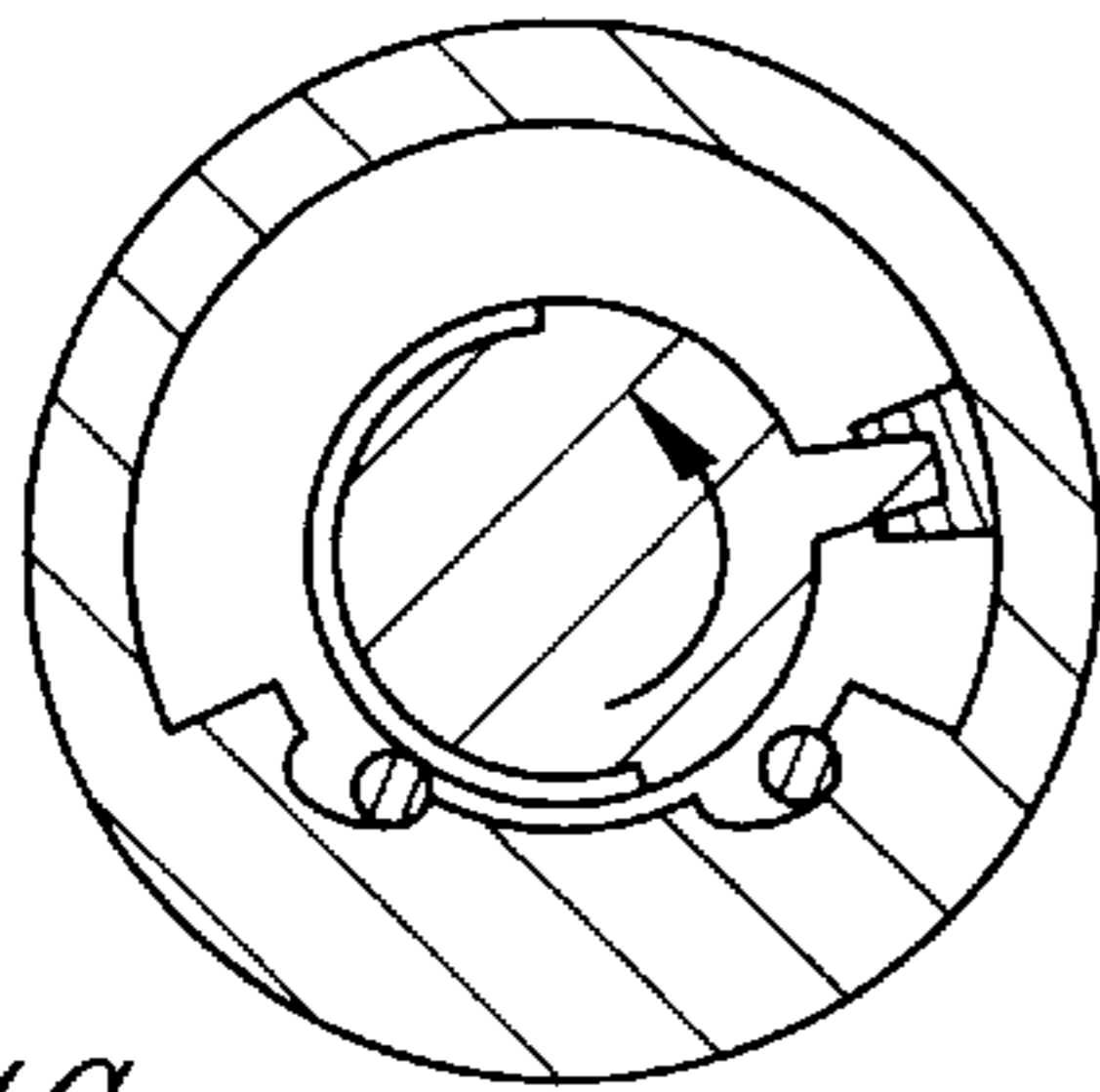
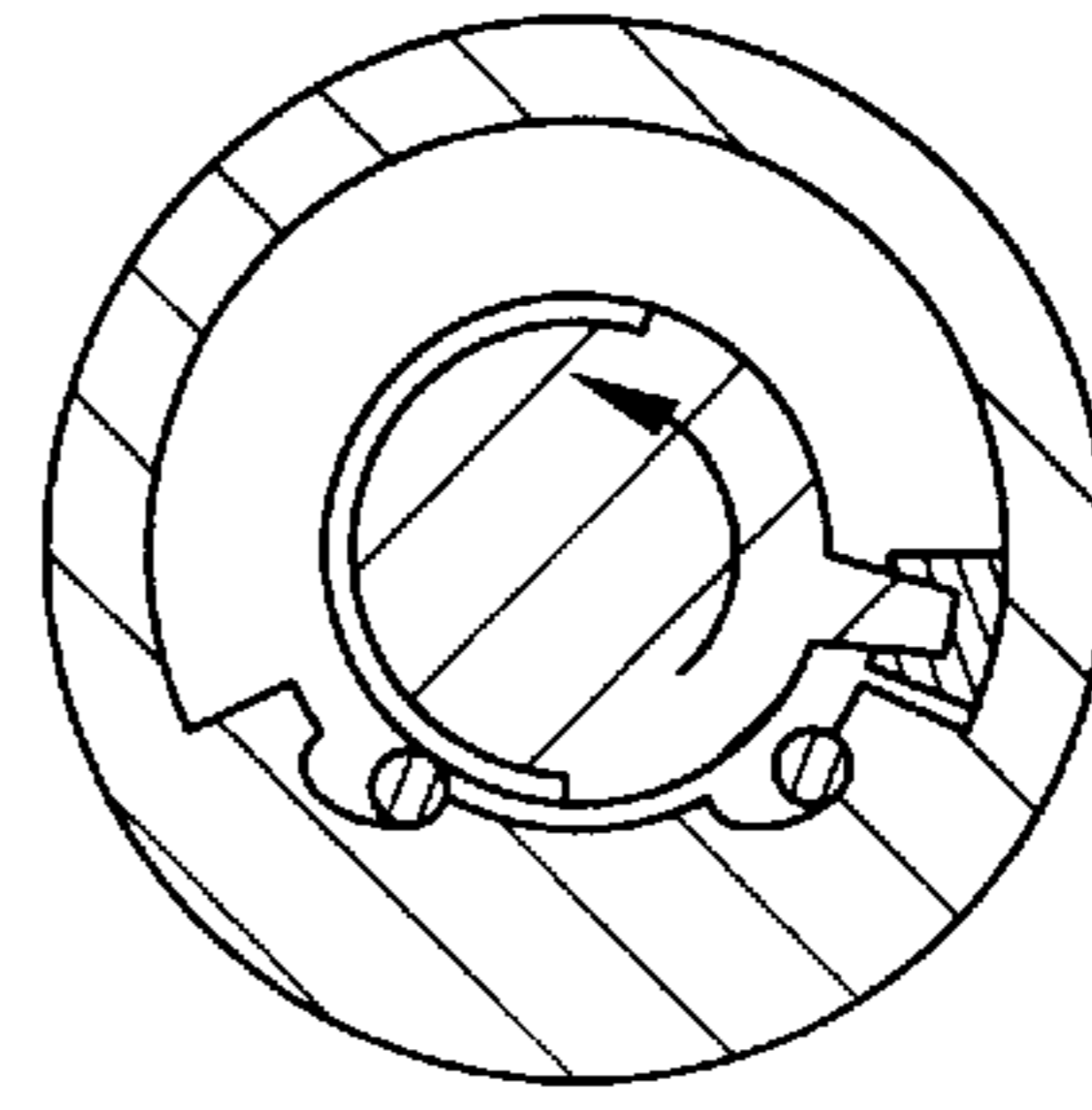
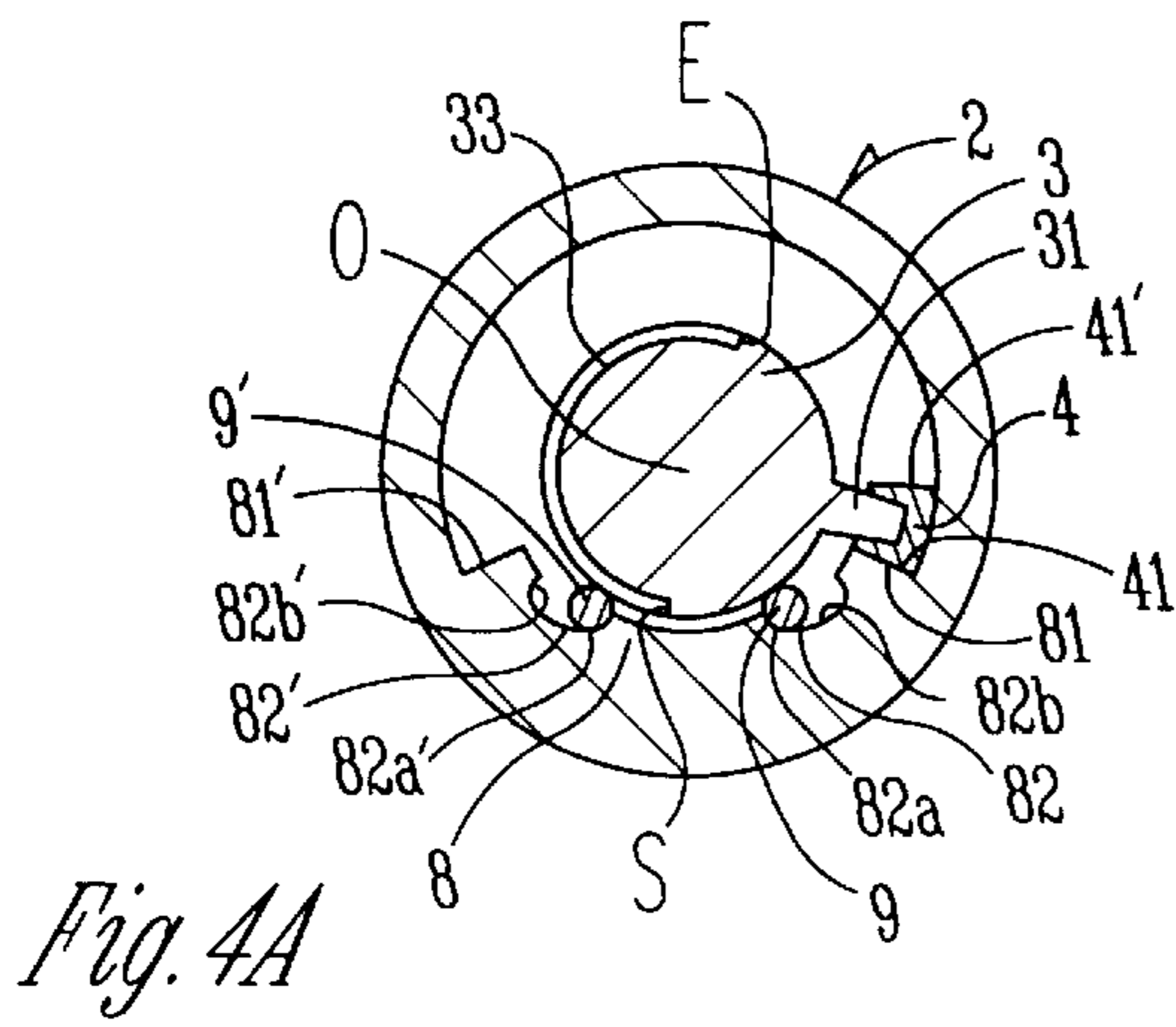

Fig. 2



*Fig. 3*



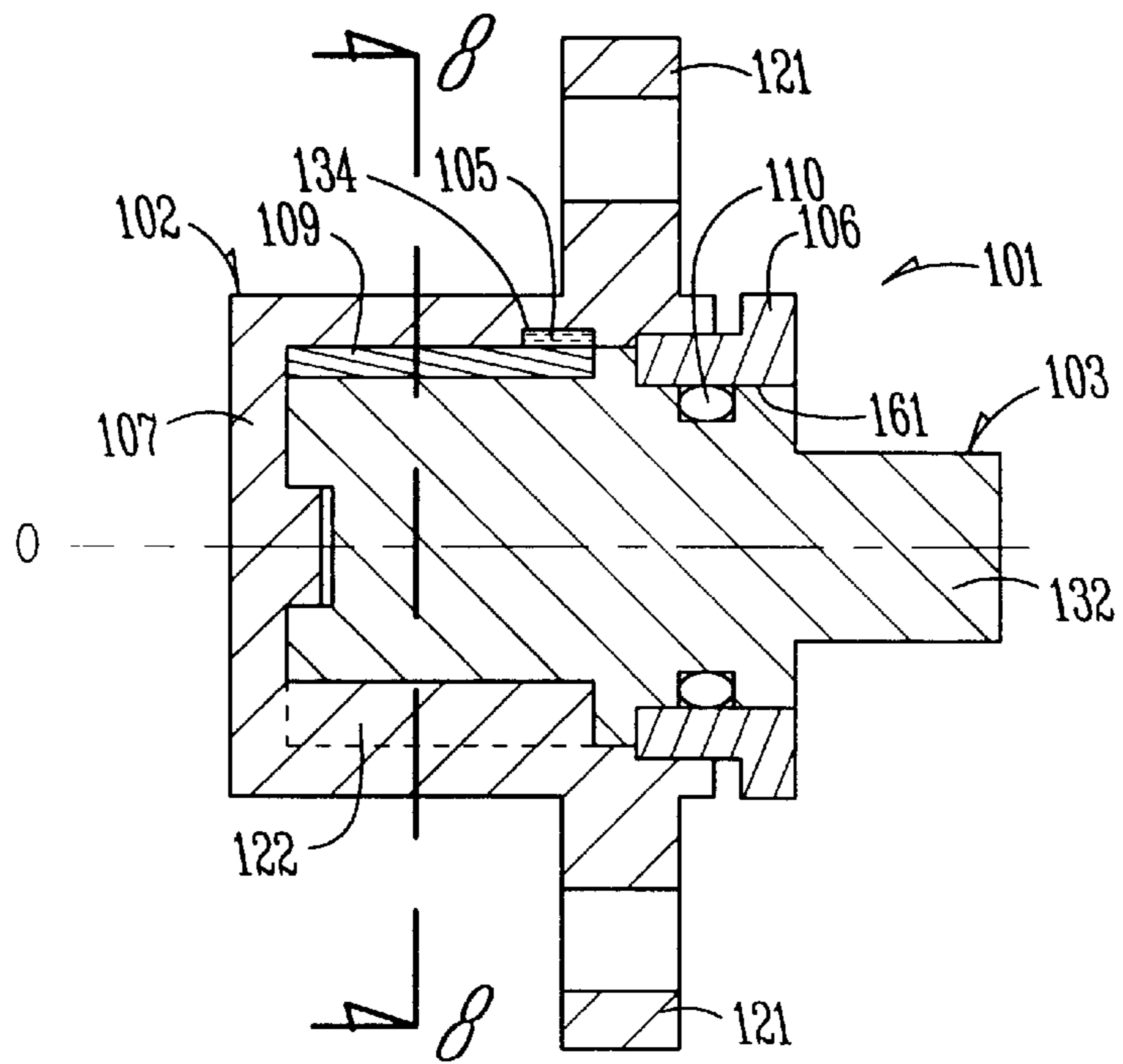

Fig. 5

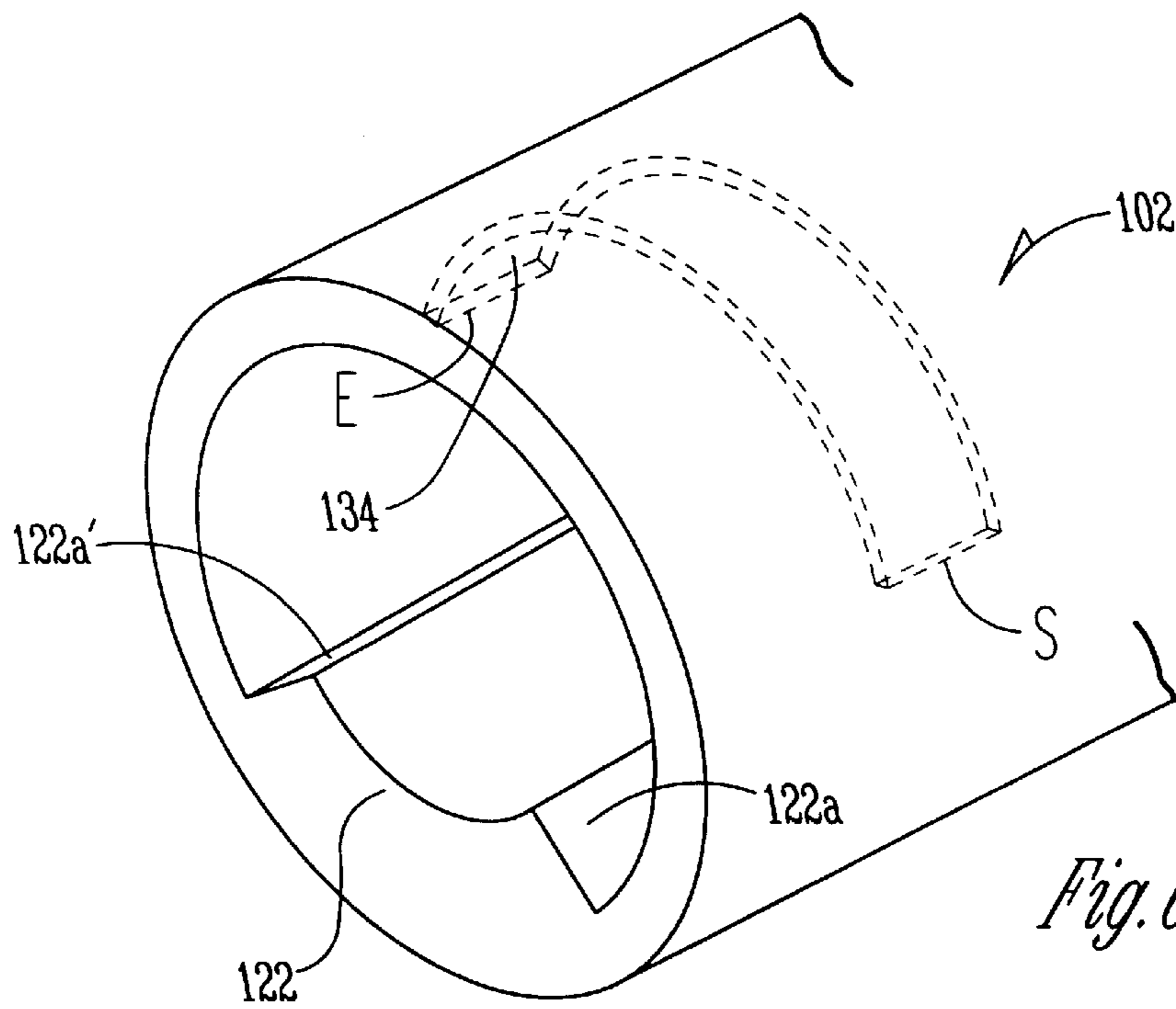
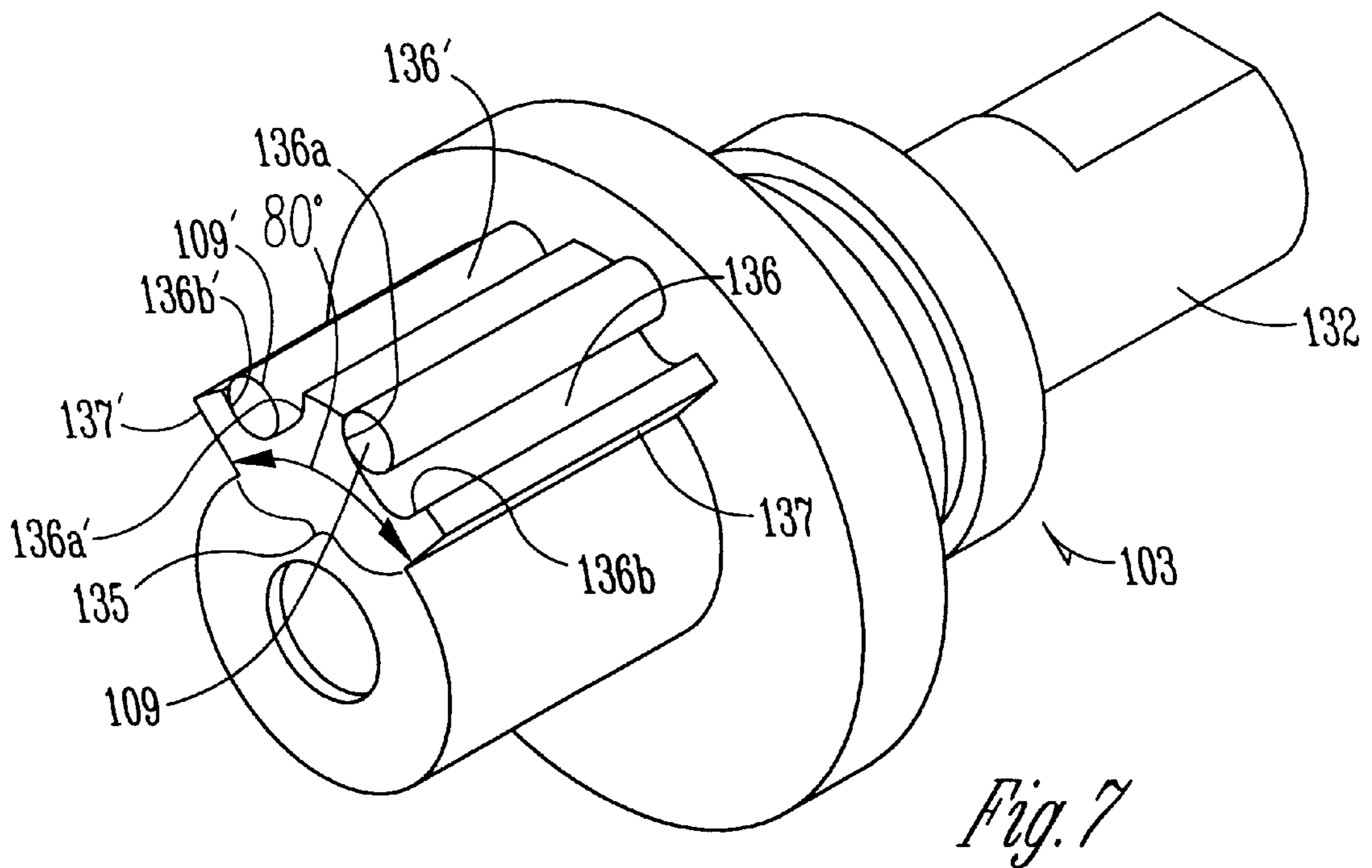

Fig. 6



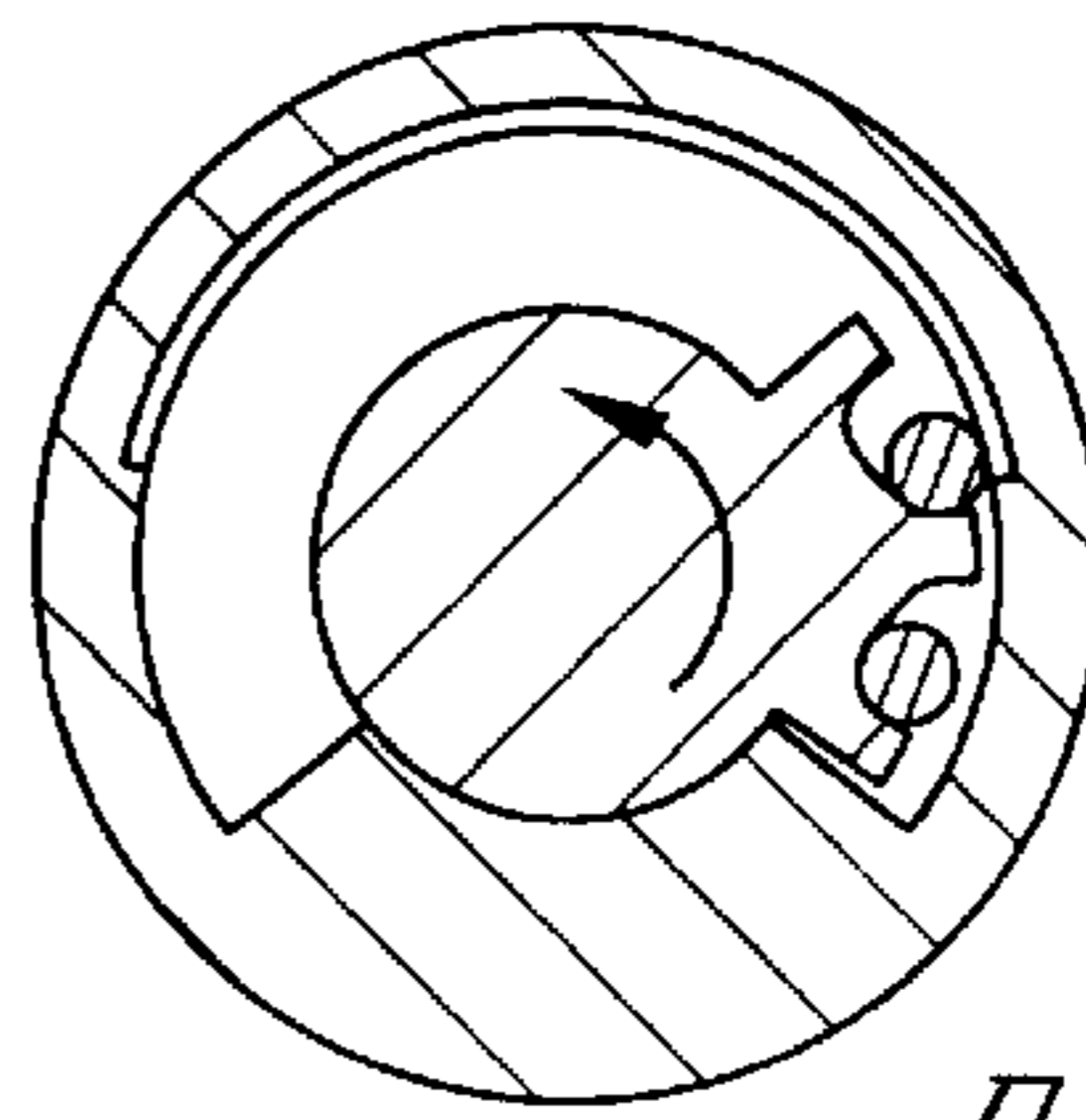
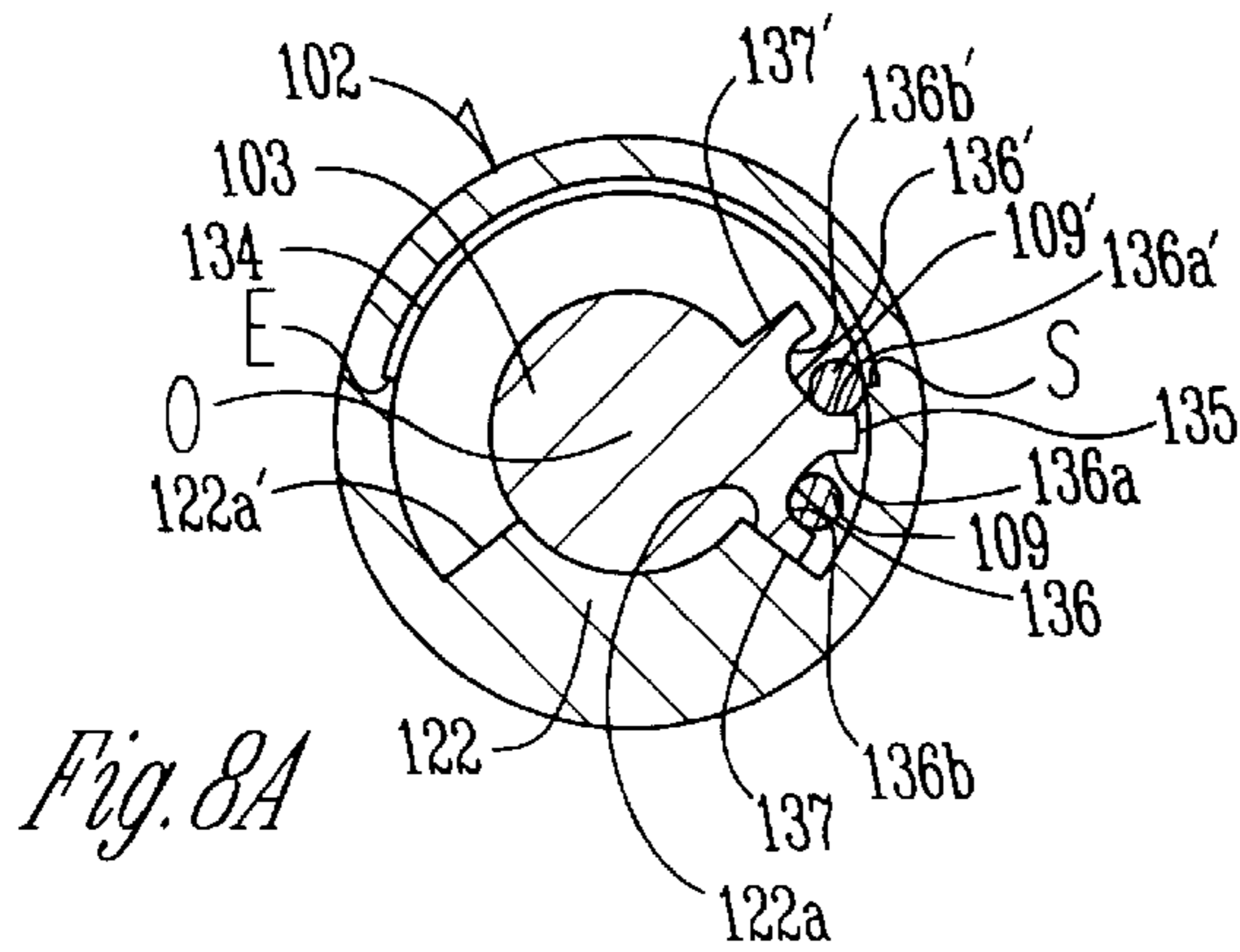

Fig. 8A

Fig. 8B

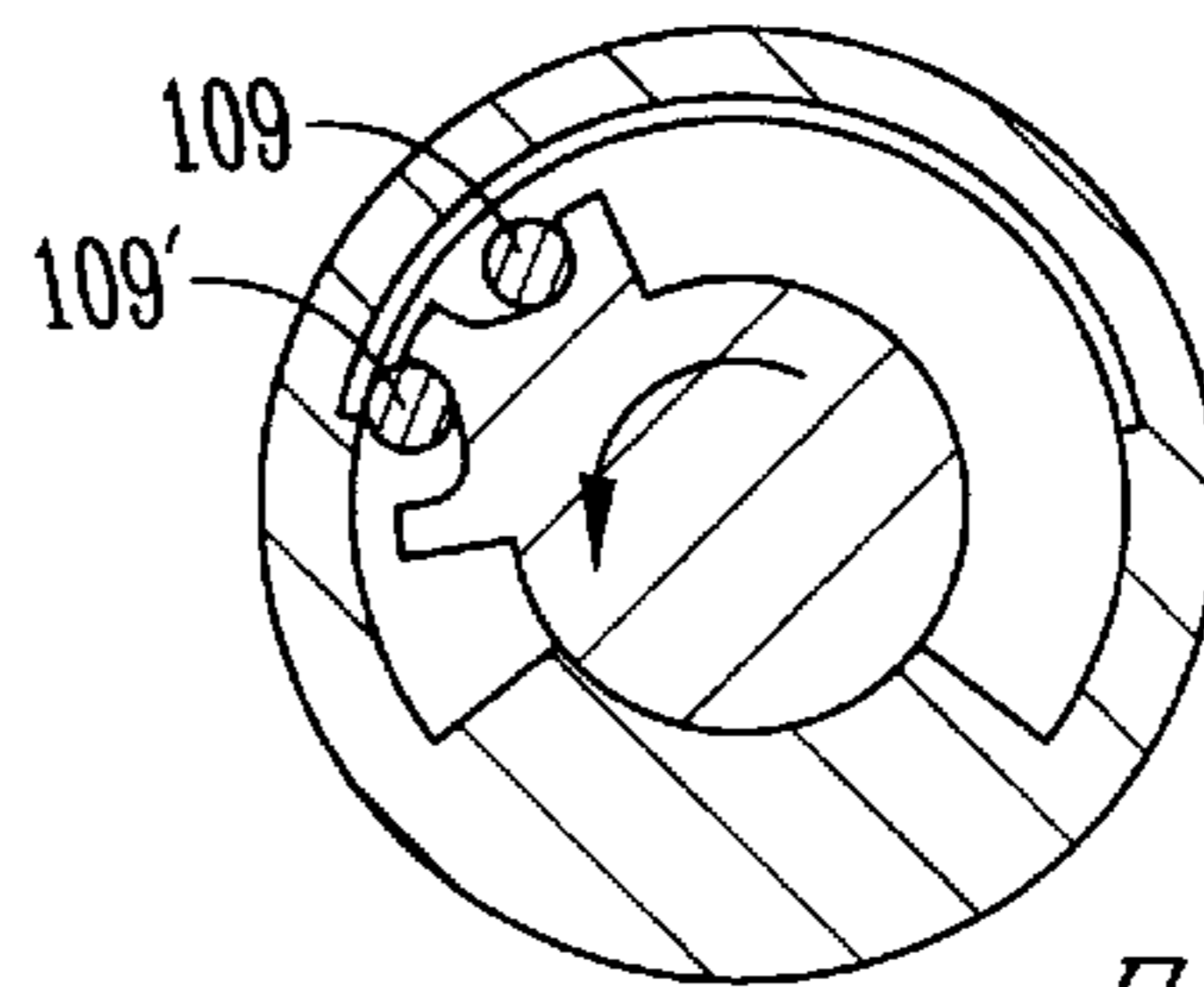
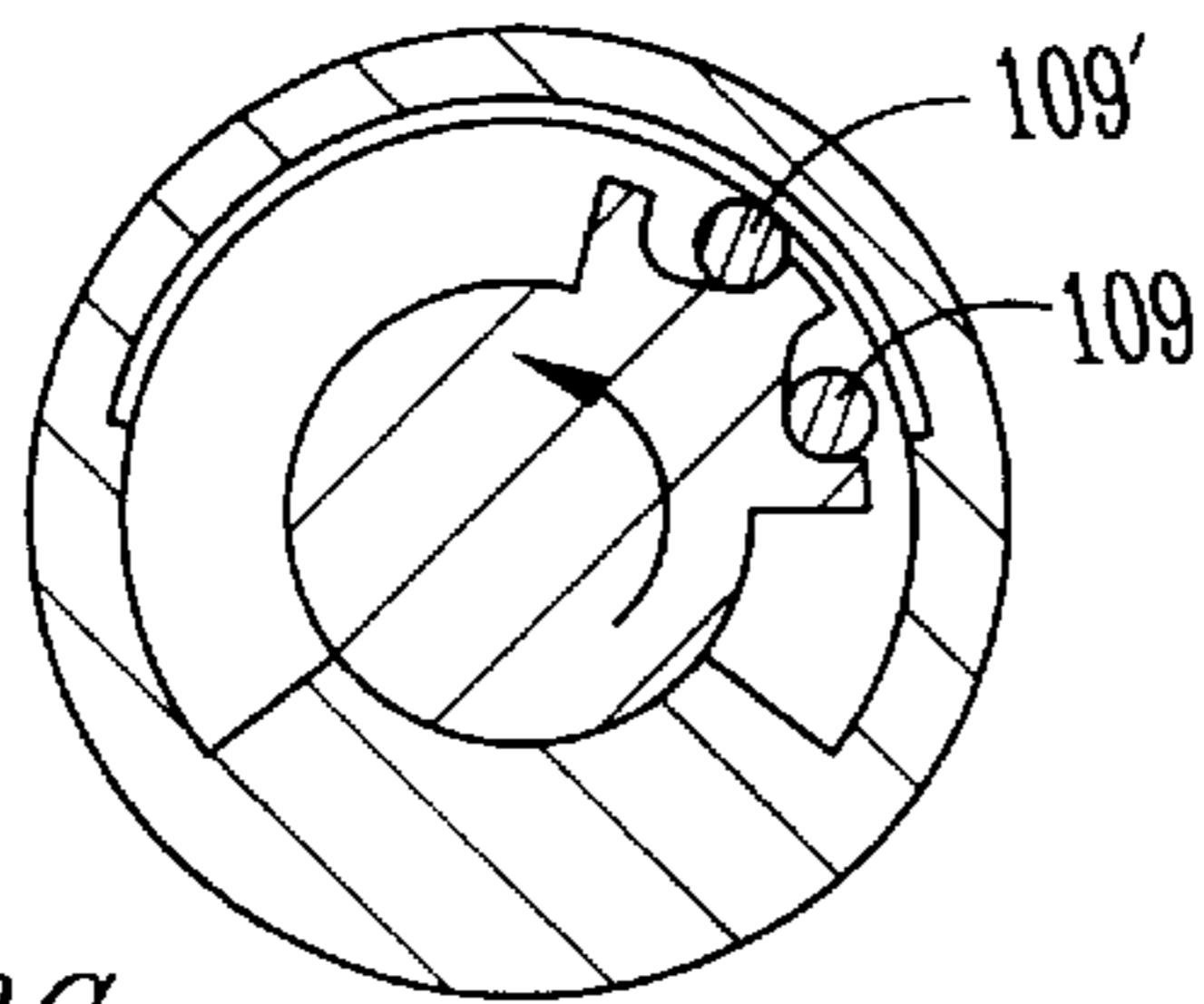

Fig. 8C

Fig. 8D

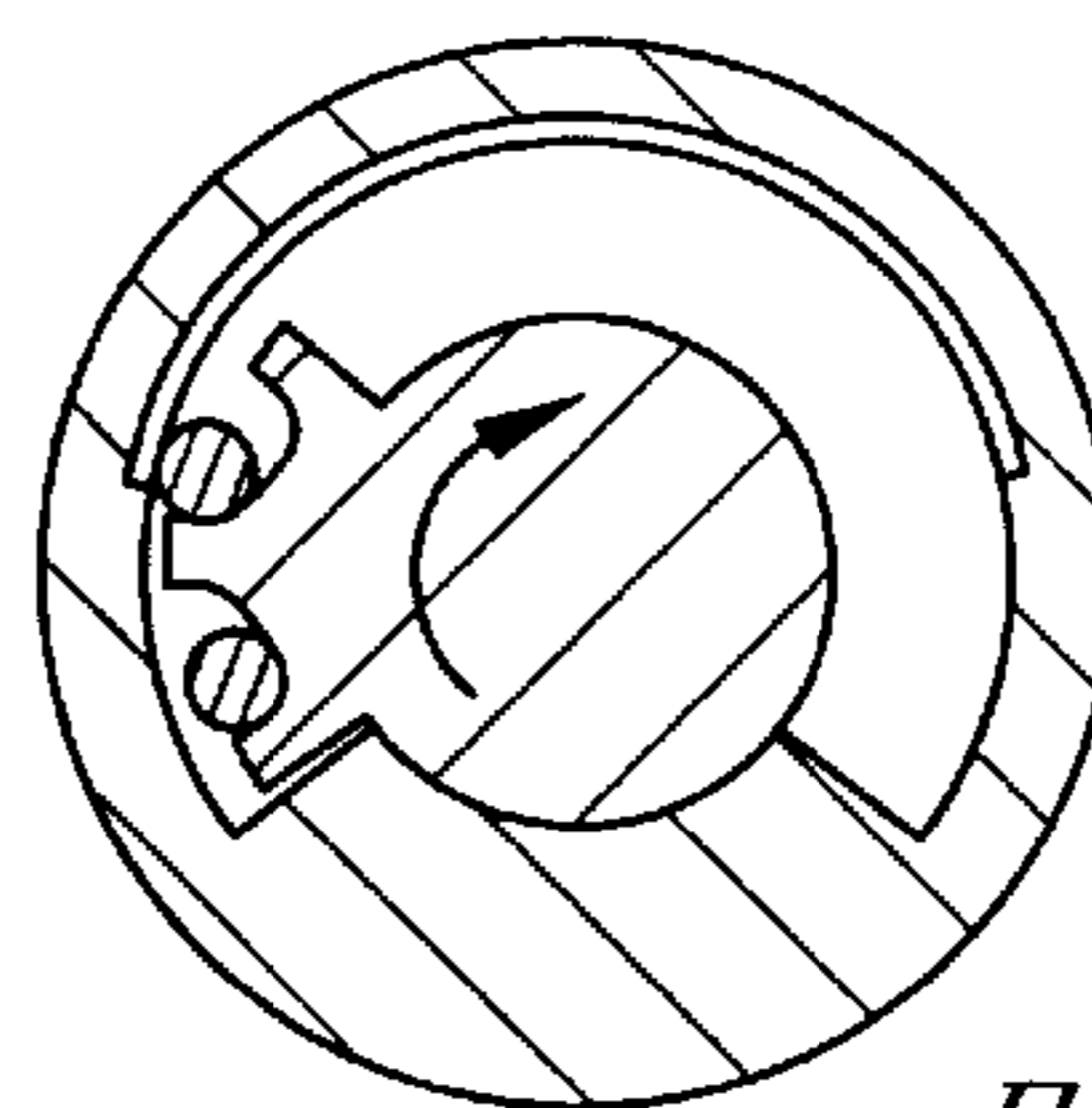
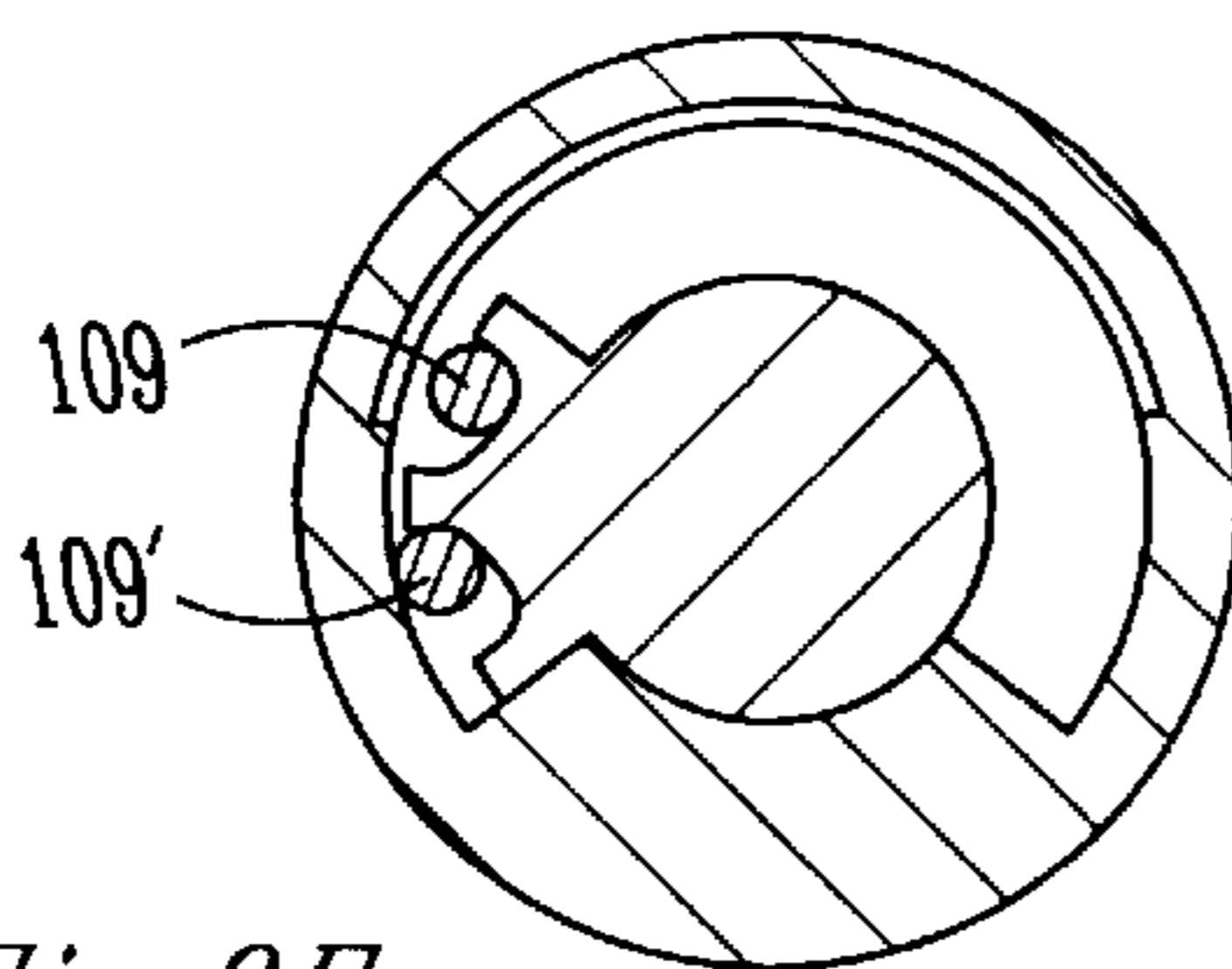

Fig. 8E

Fig. 8F

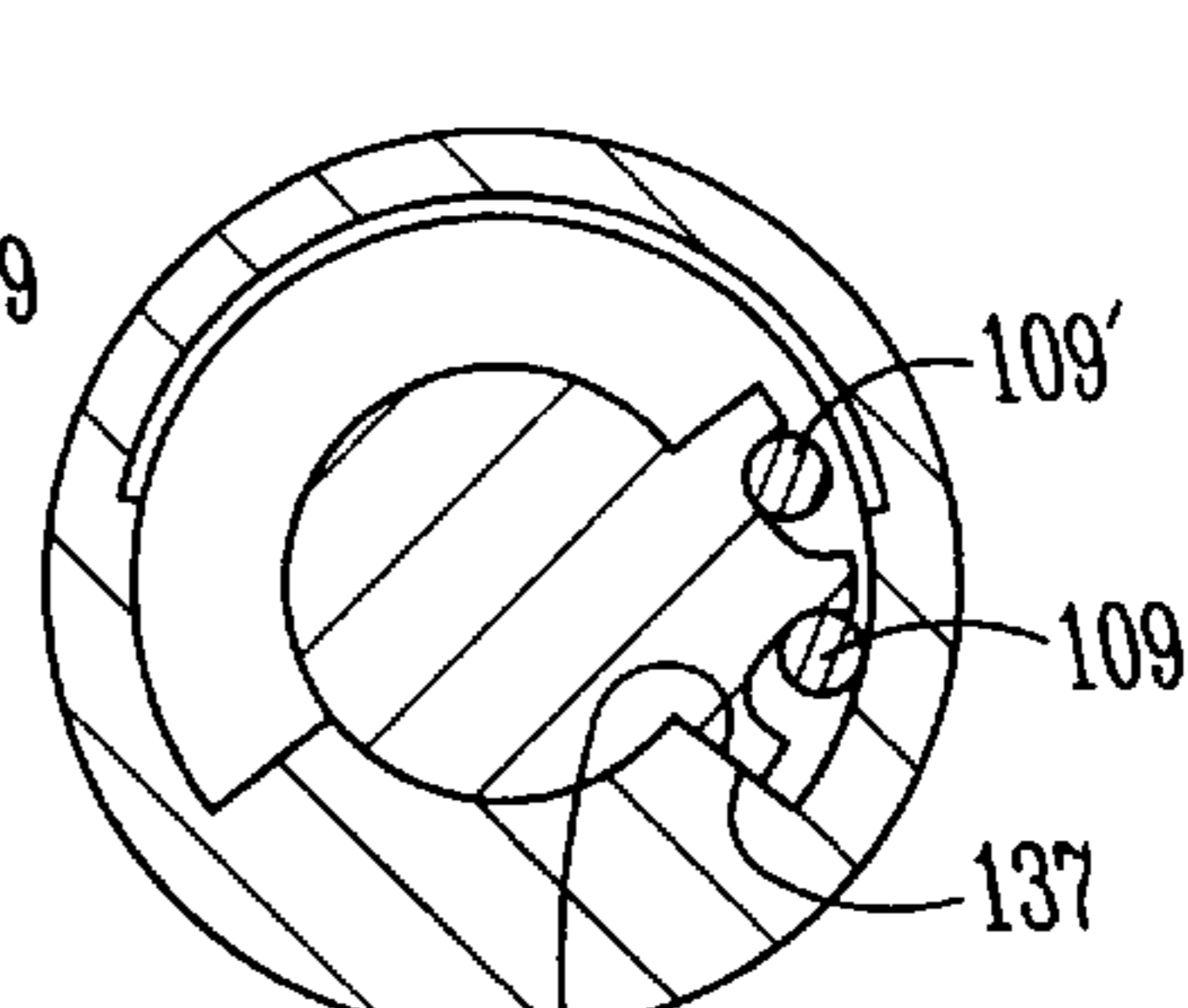
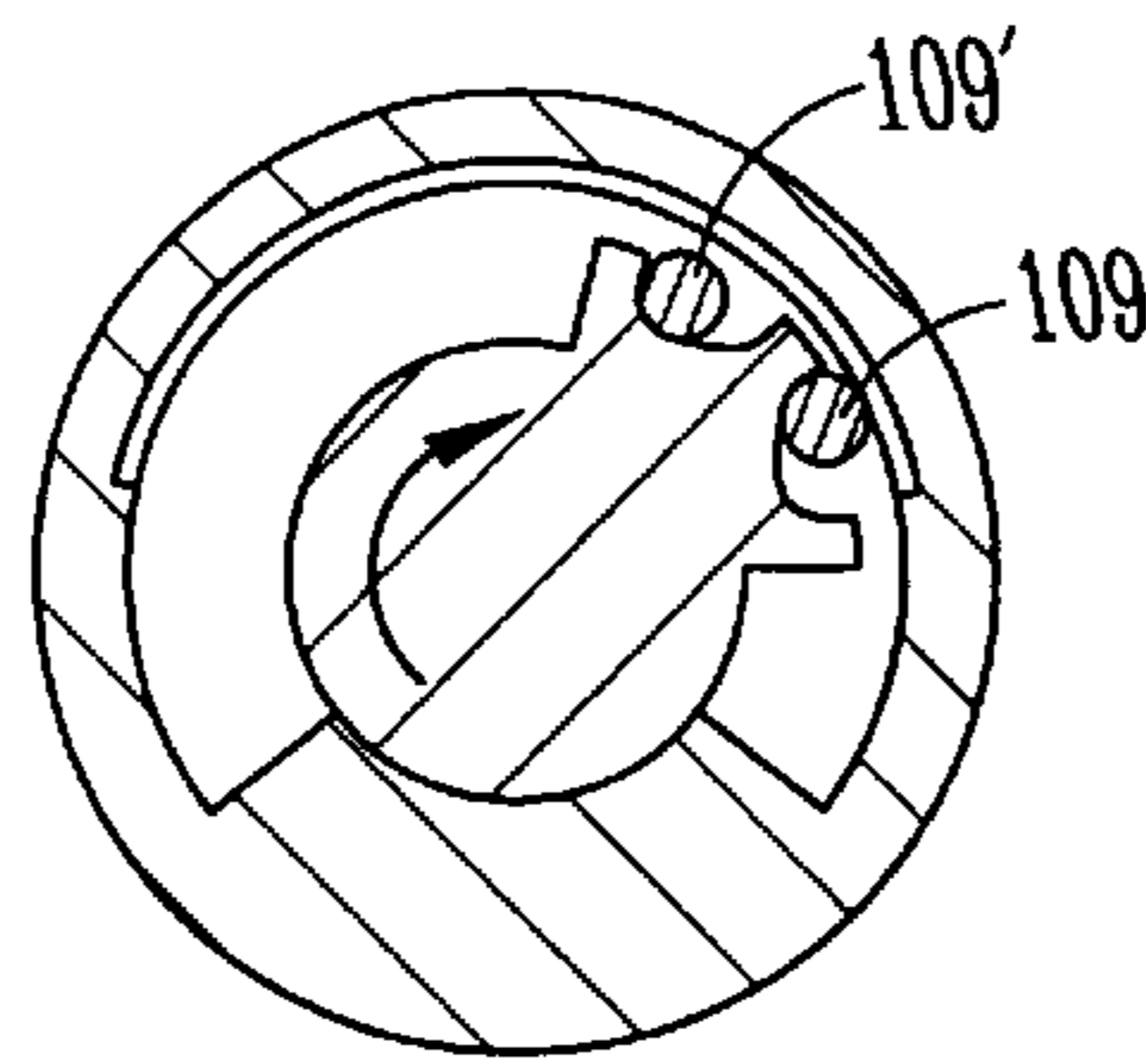
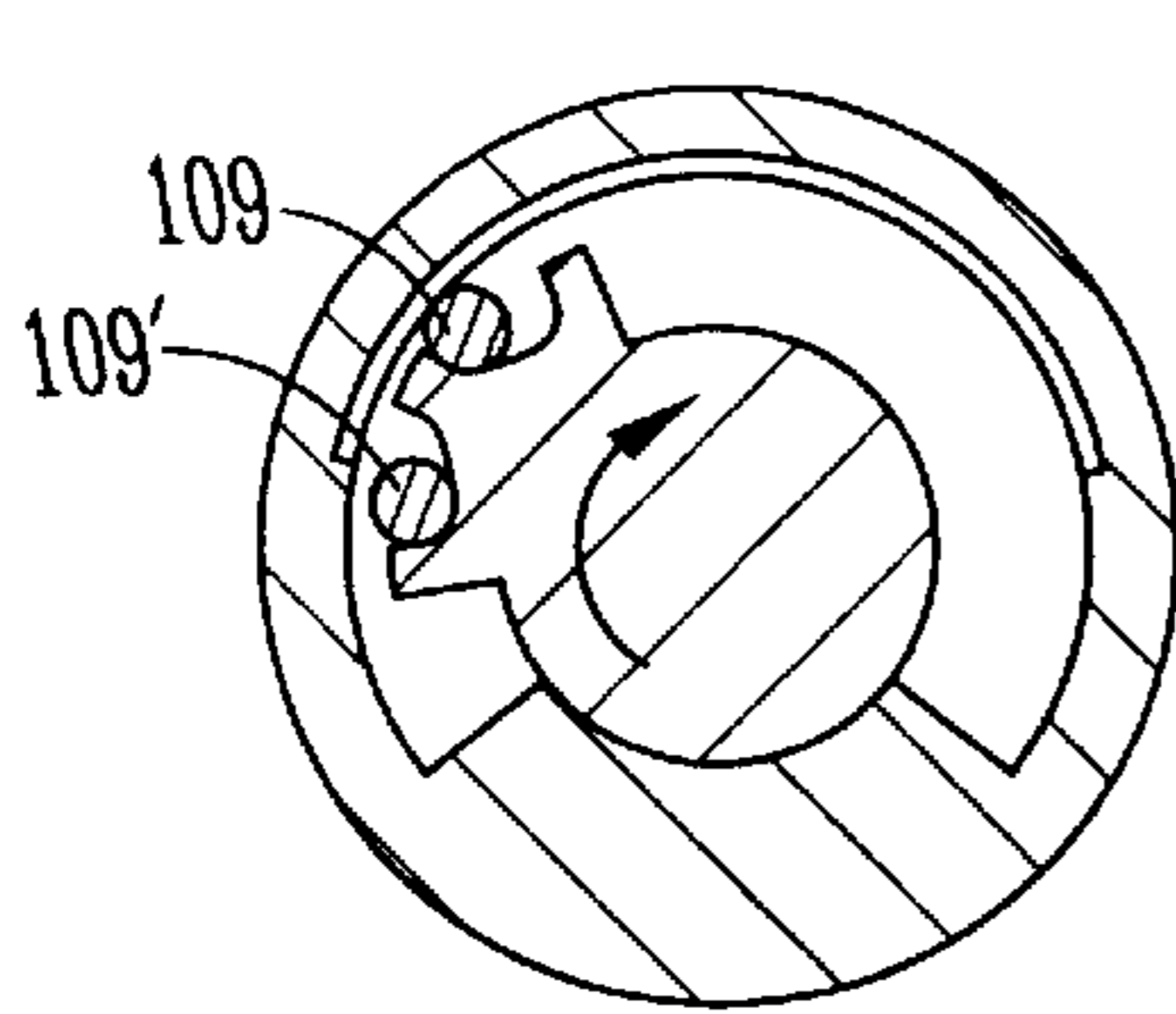

Fig. 8G

Fig. 8H

Fig. 8I

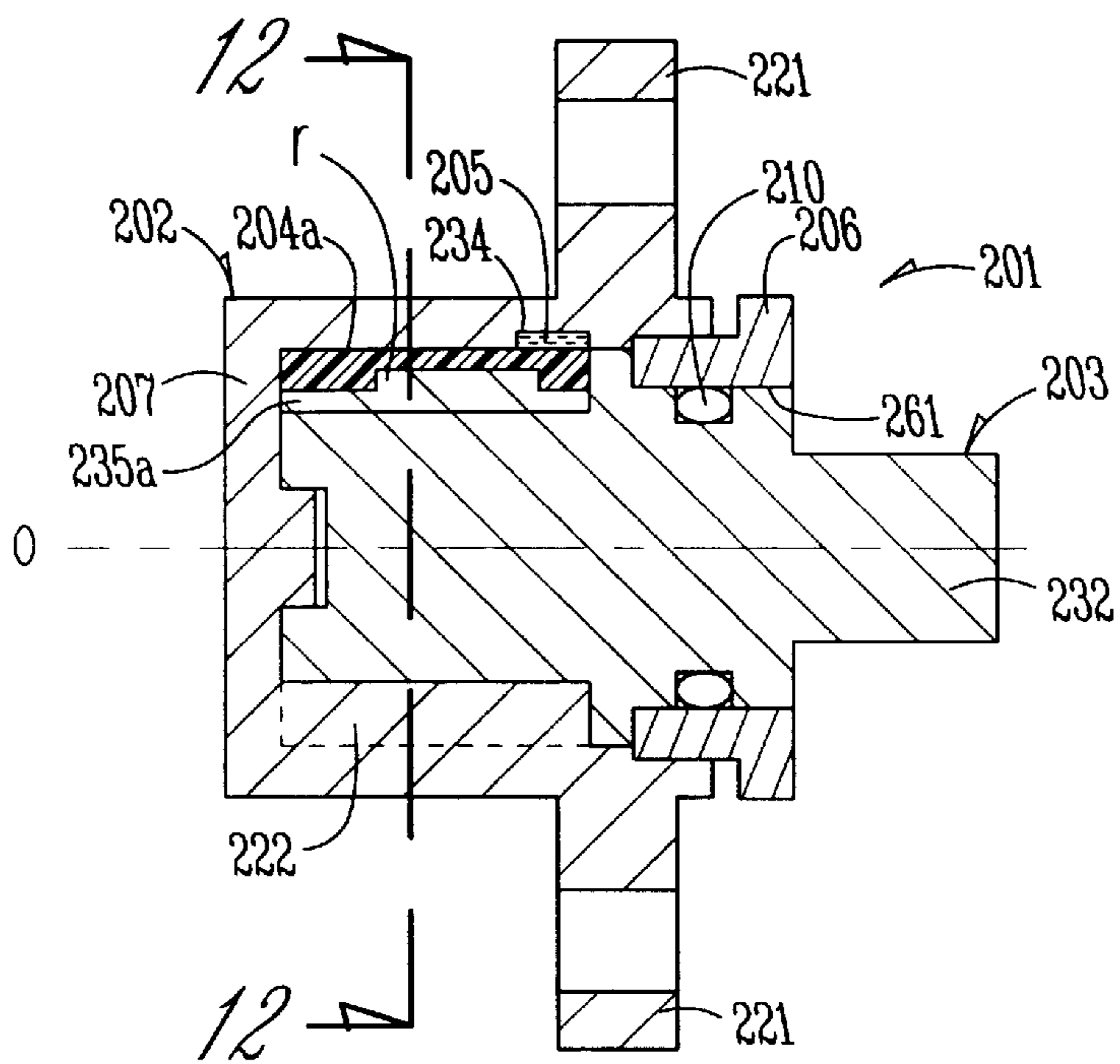

Fig. 9

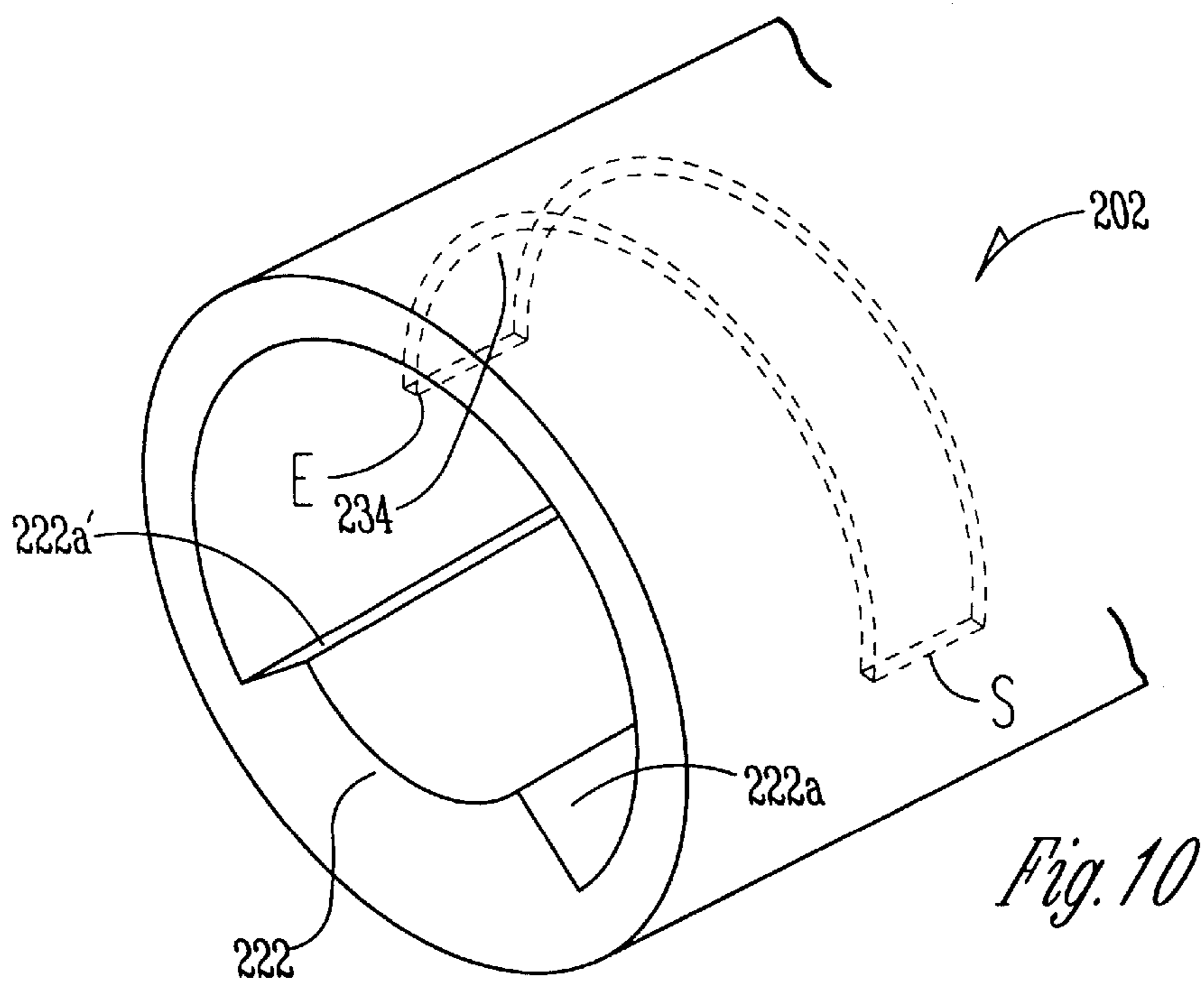
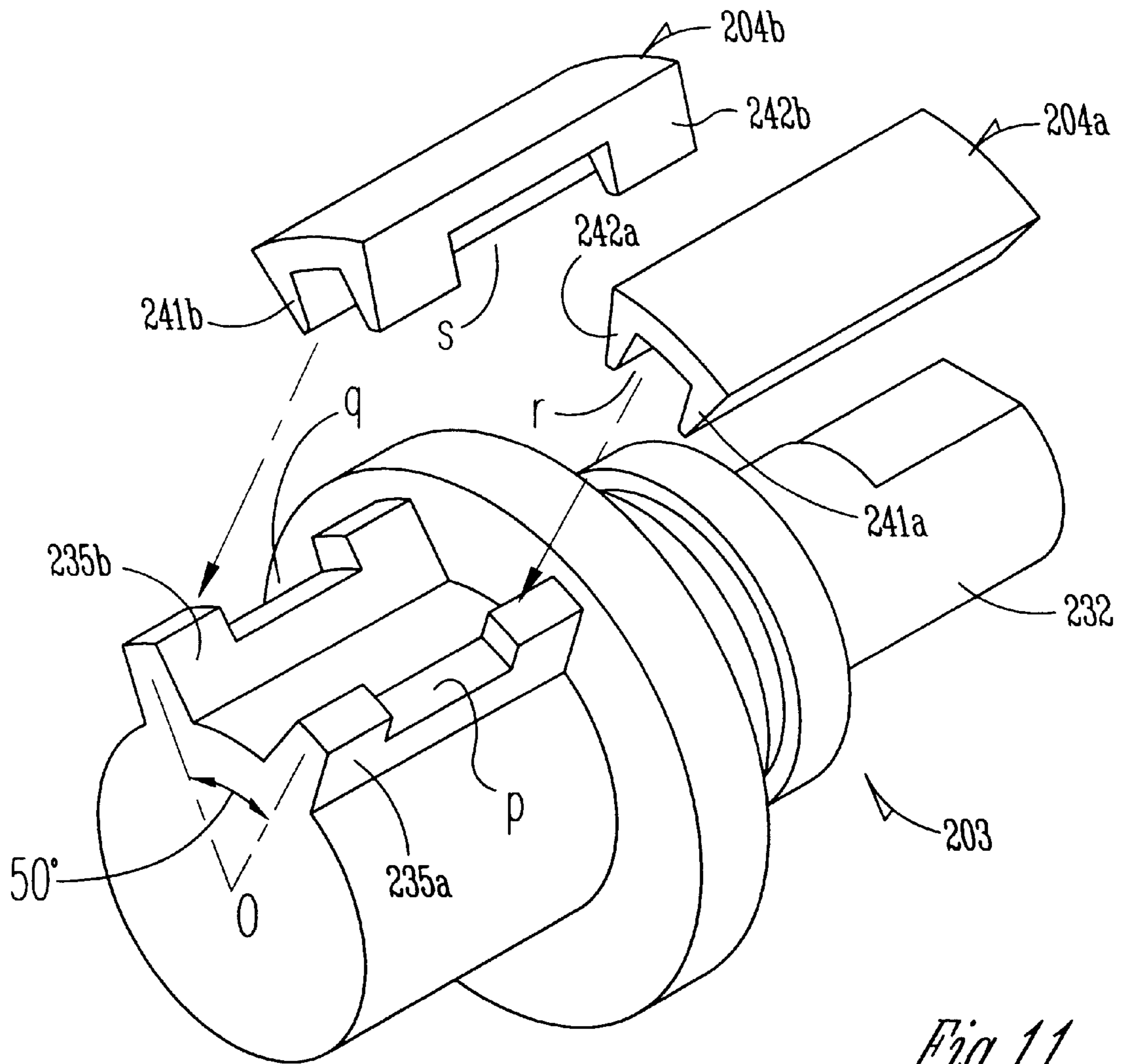

Fig. 10





*Fig. 11*

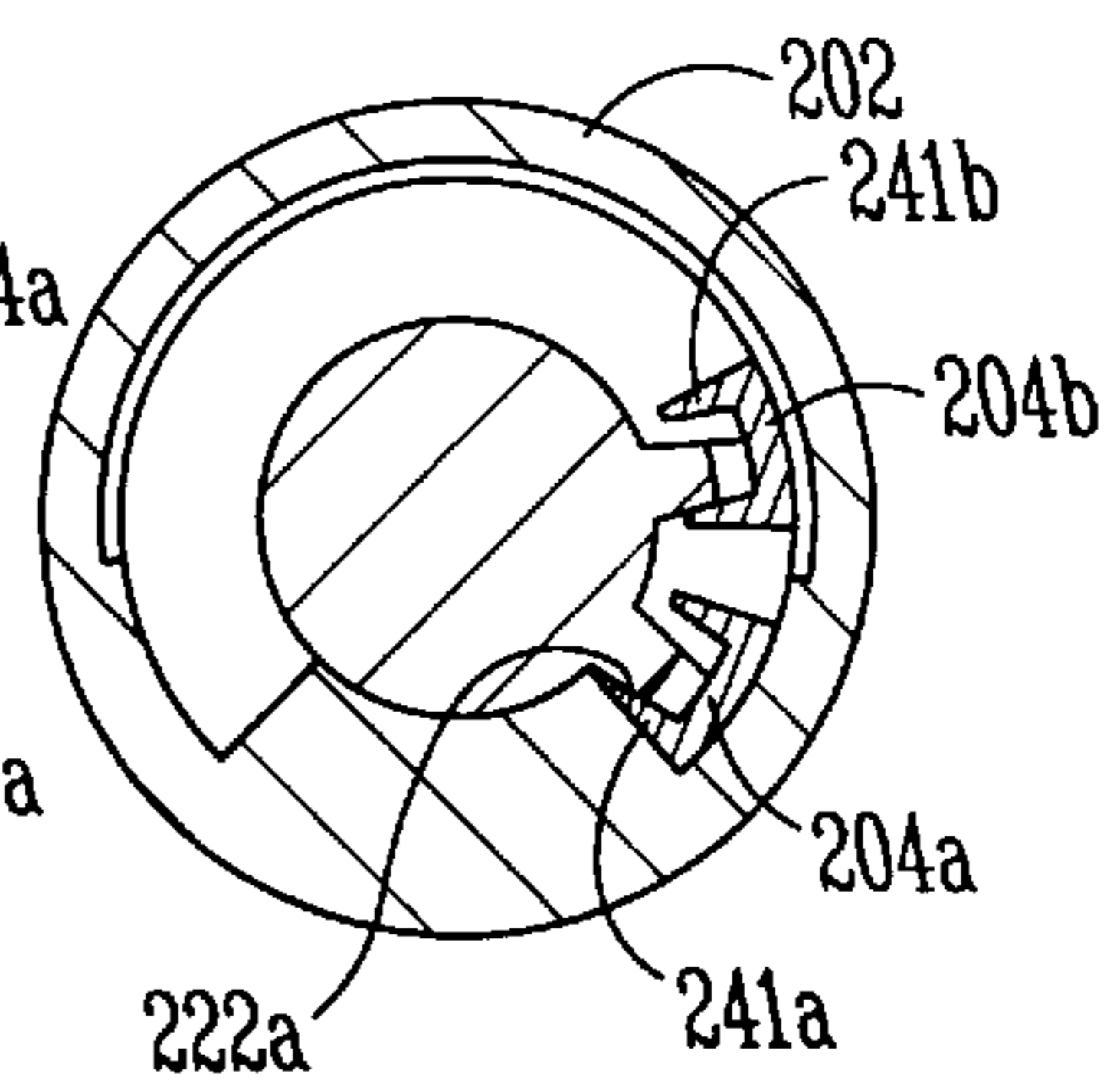
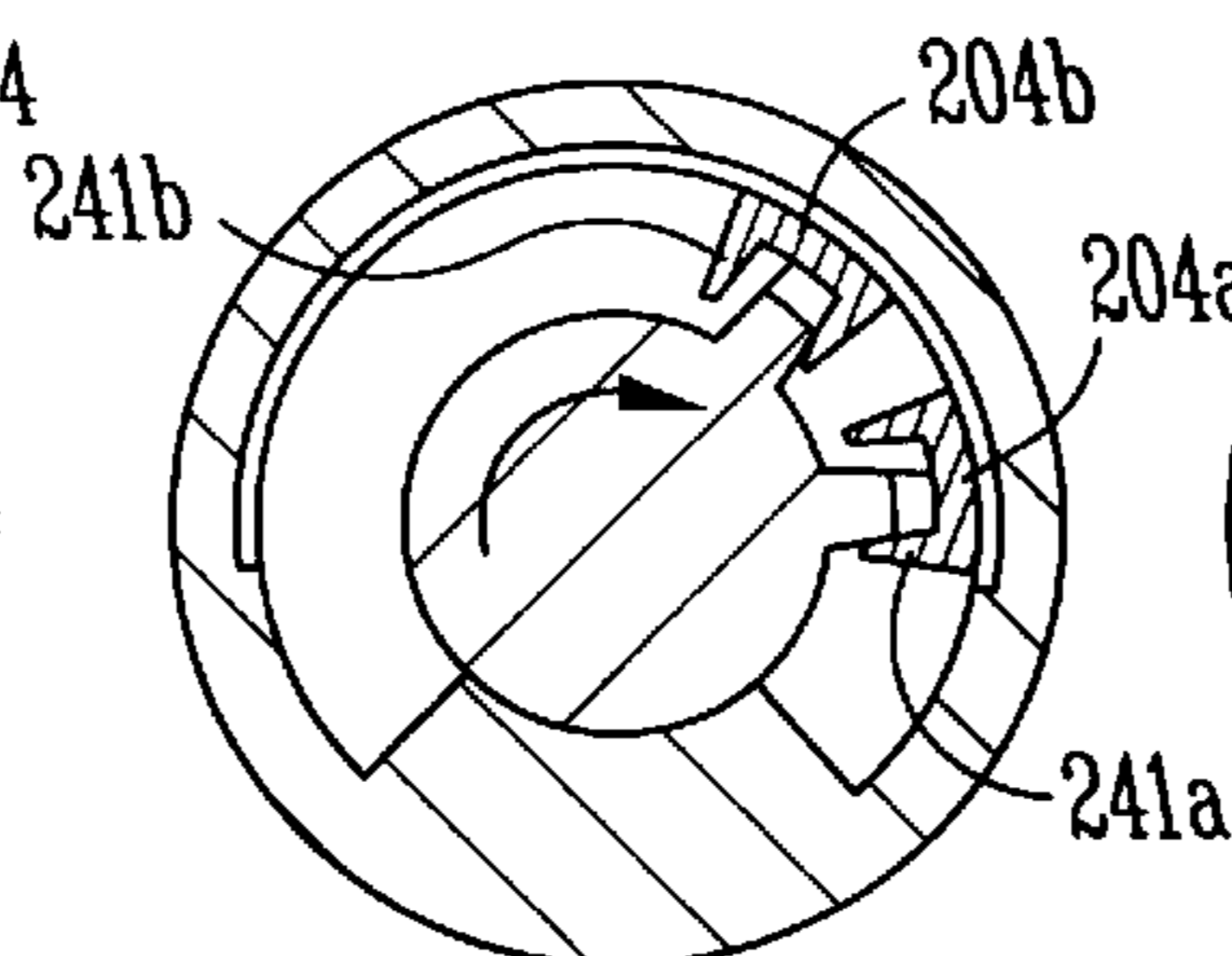
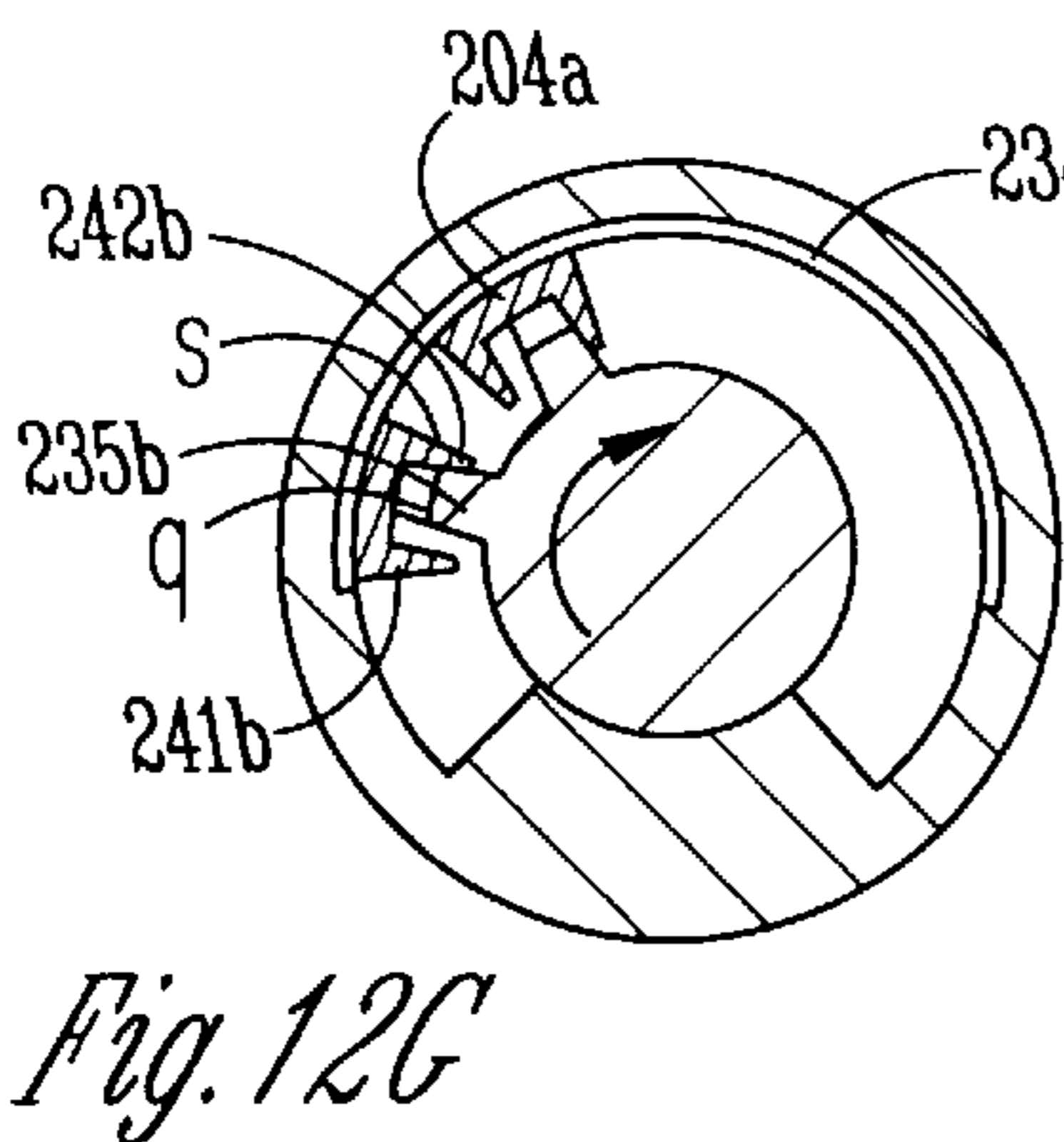
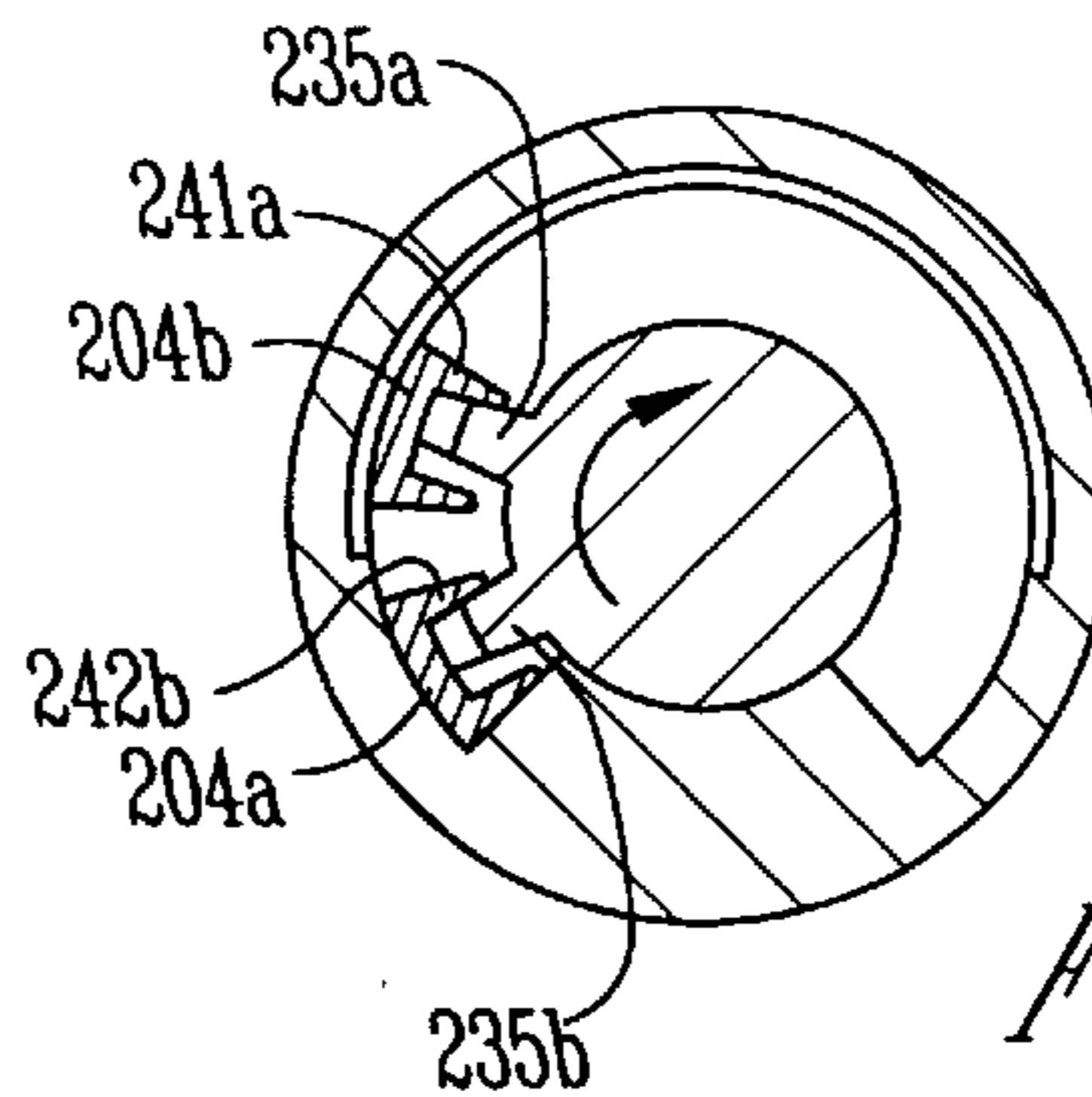
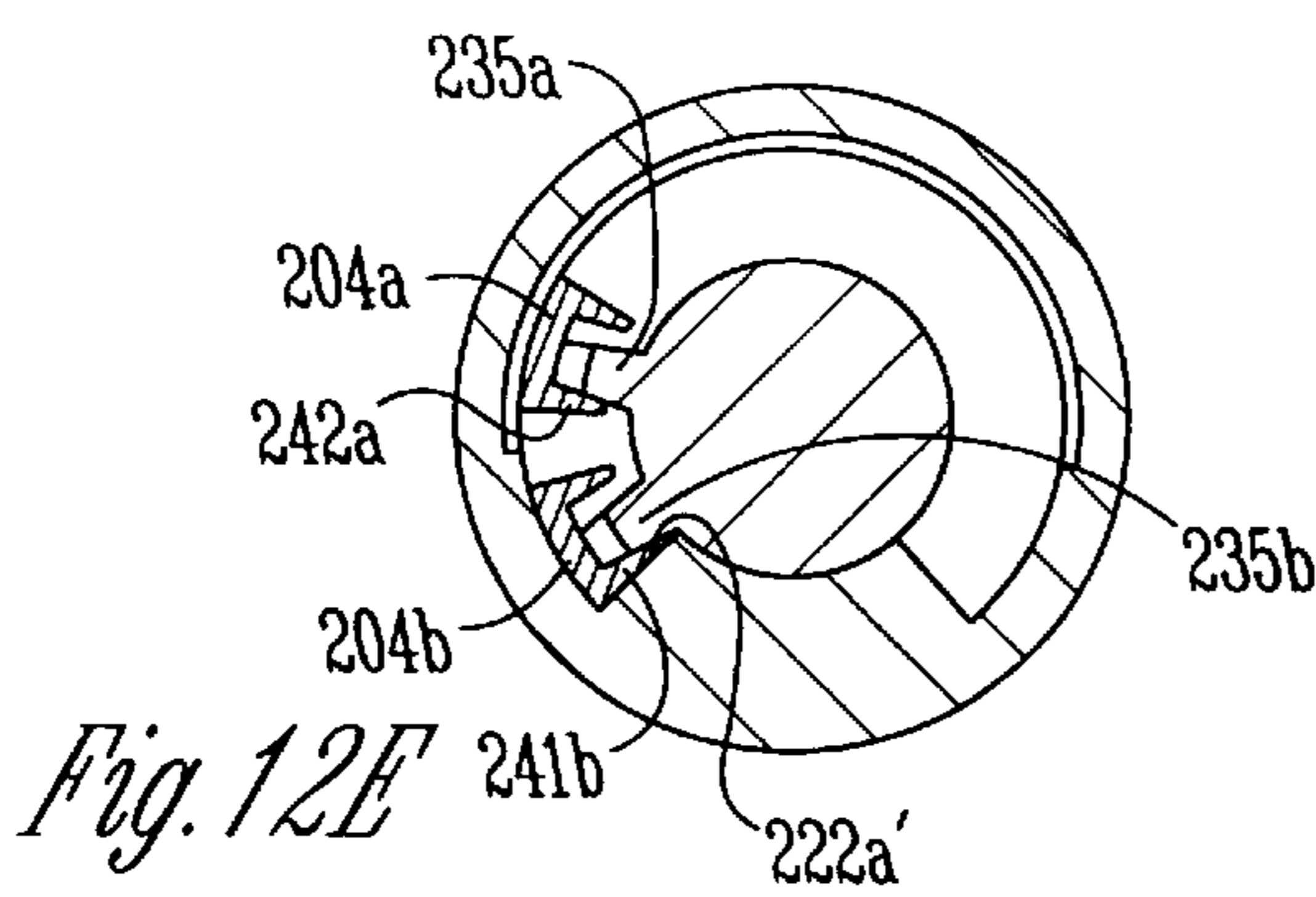
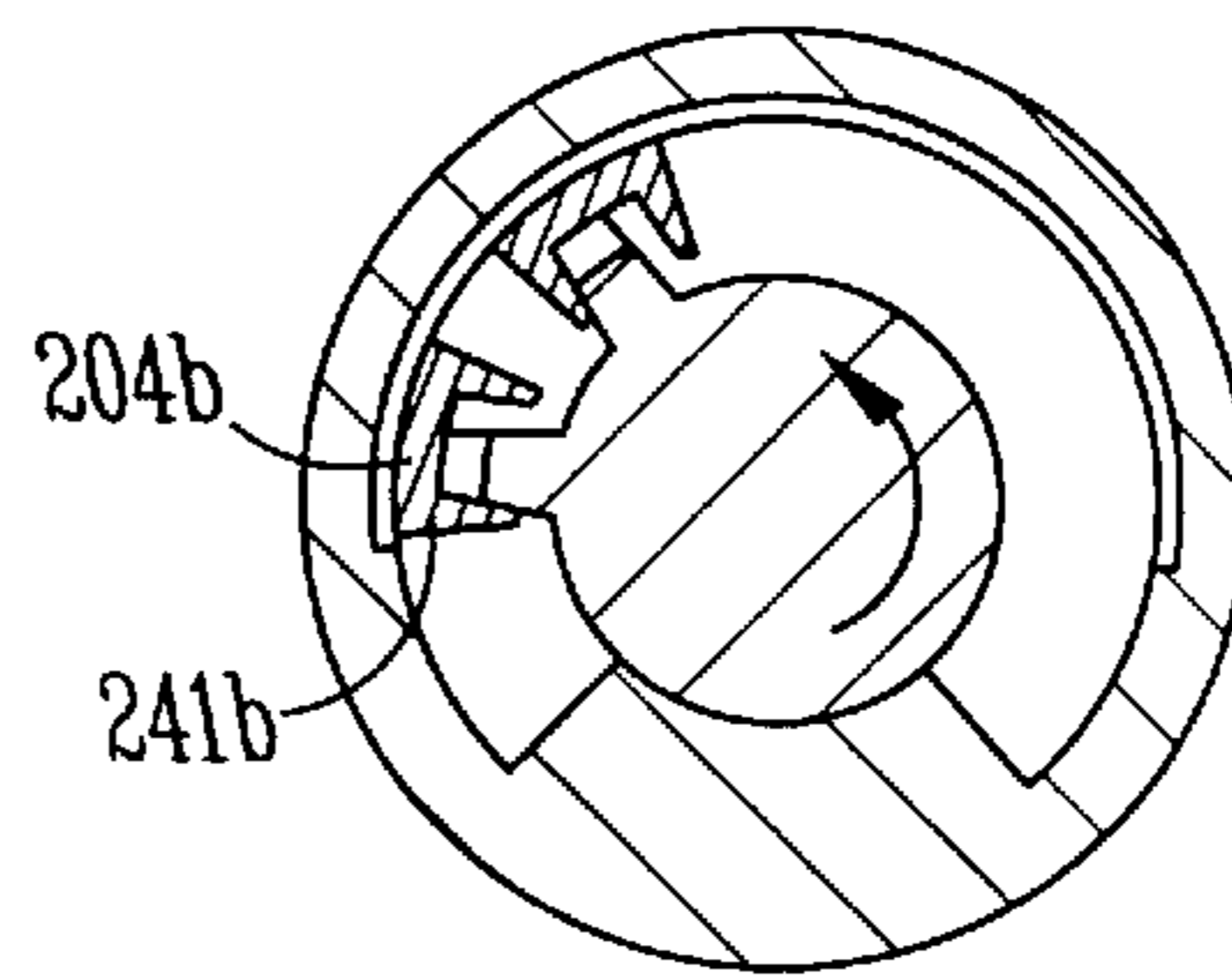
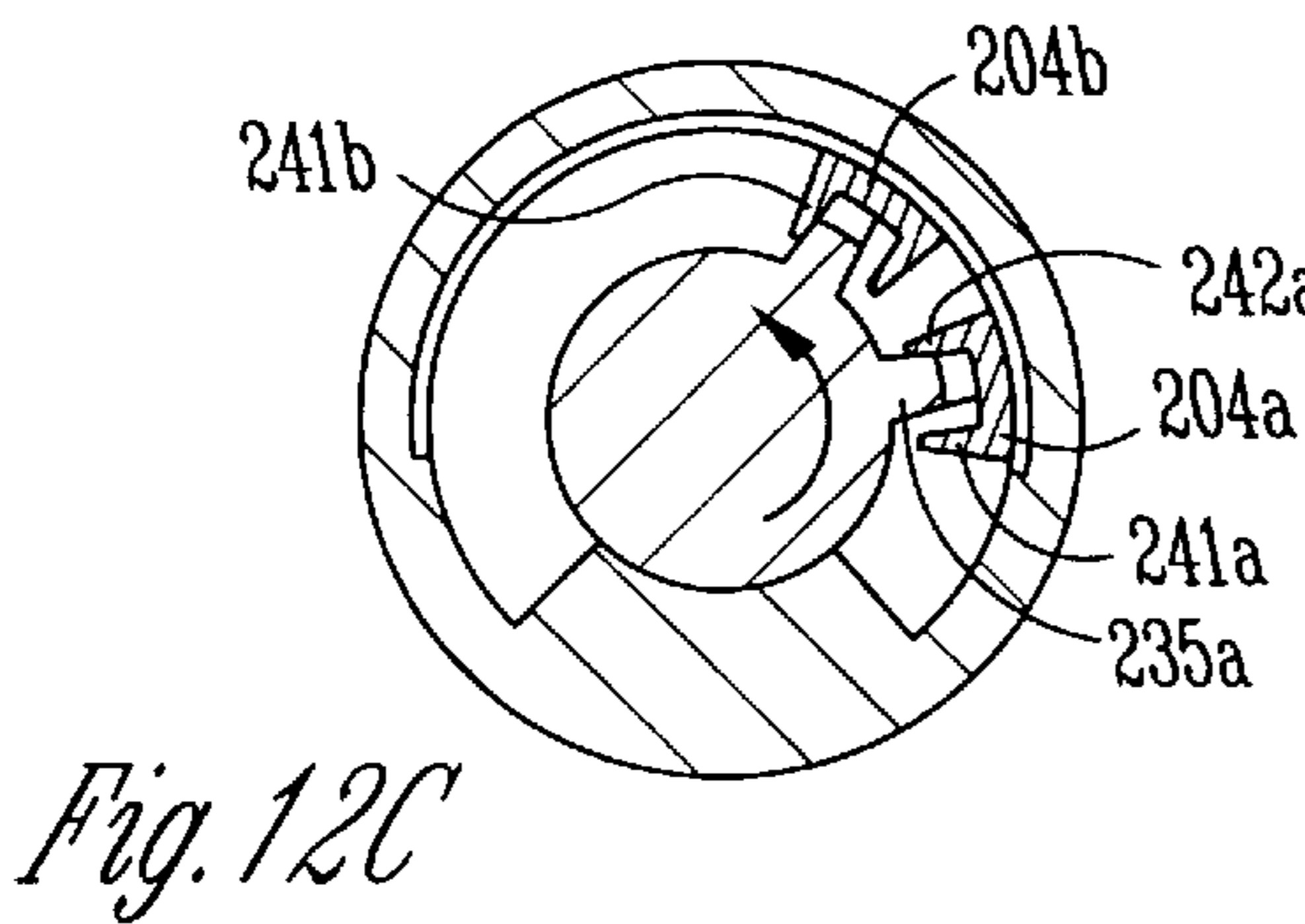
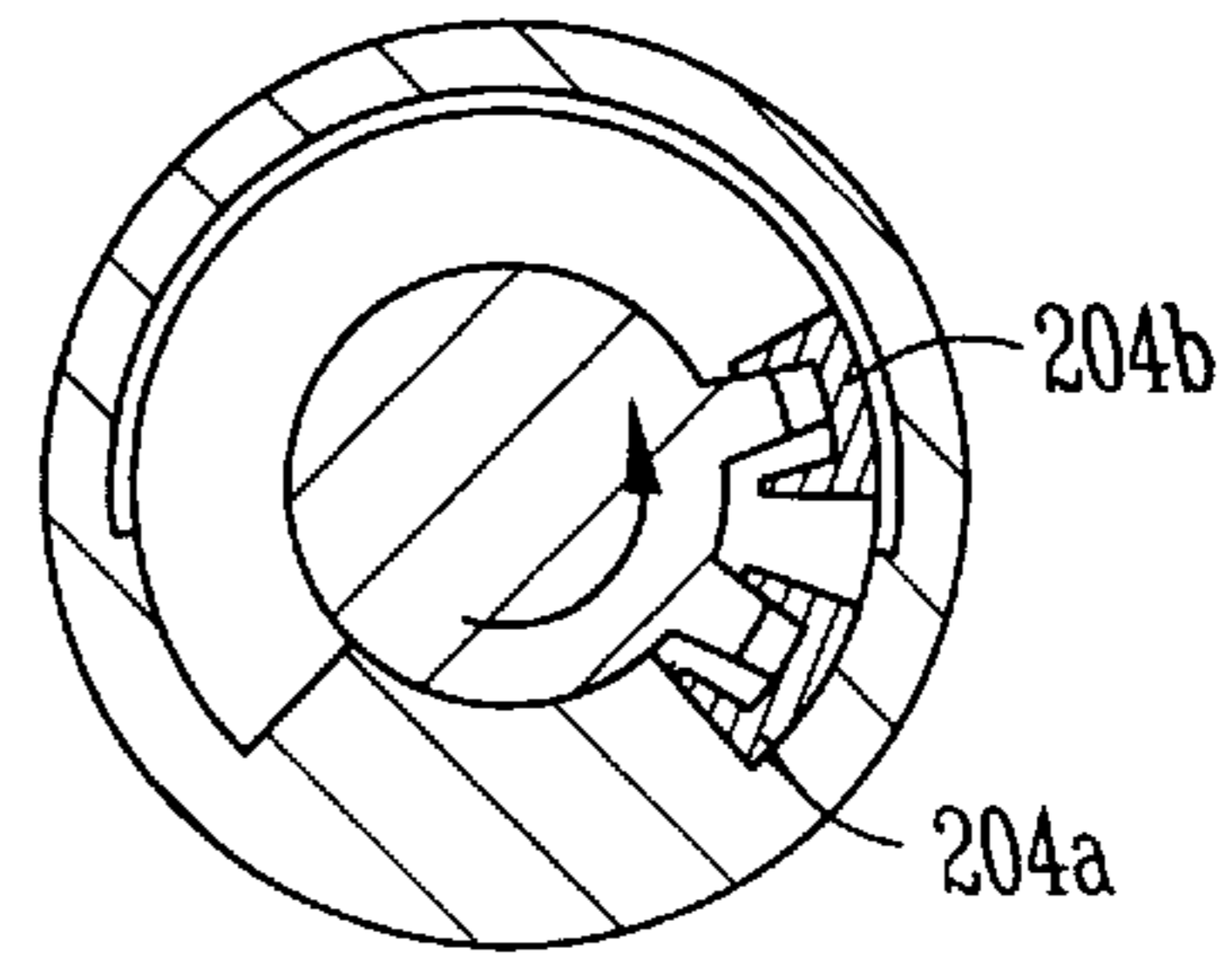
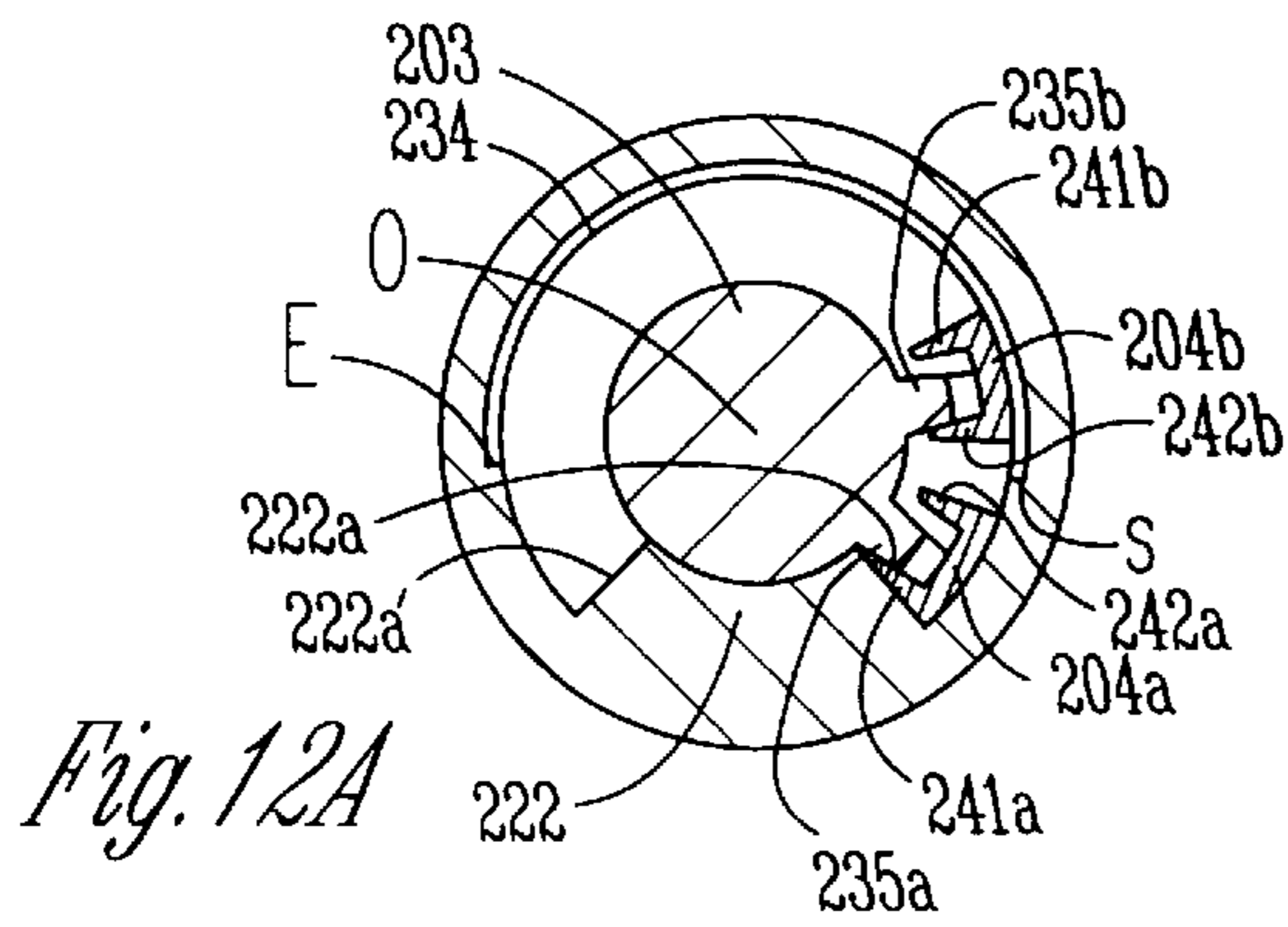
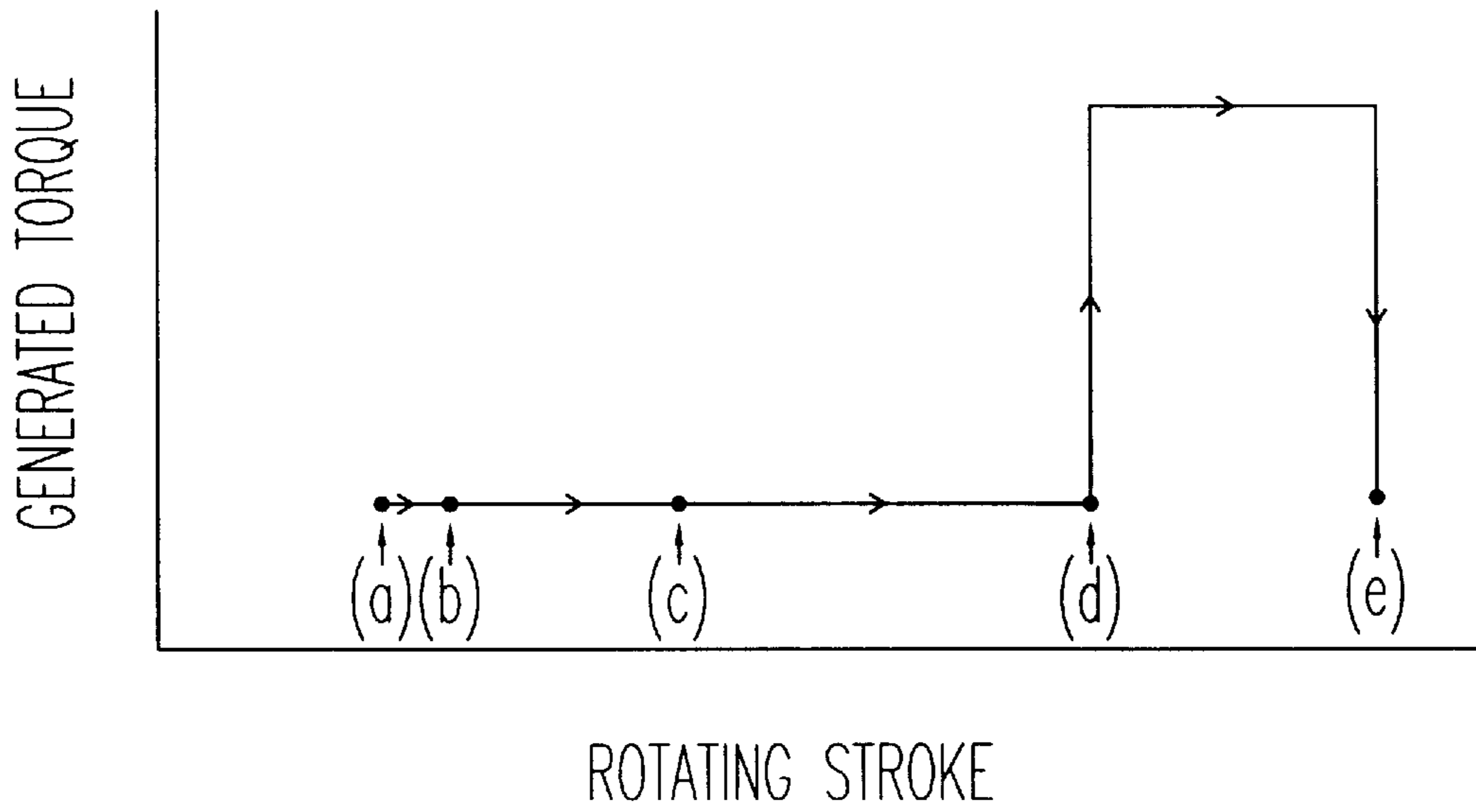
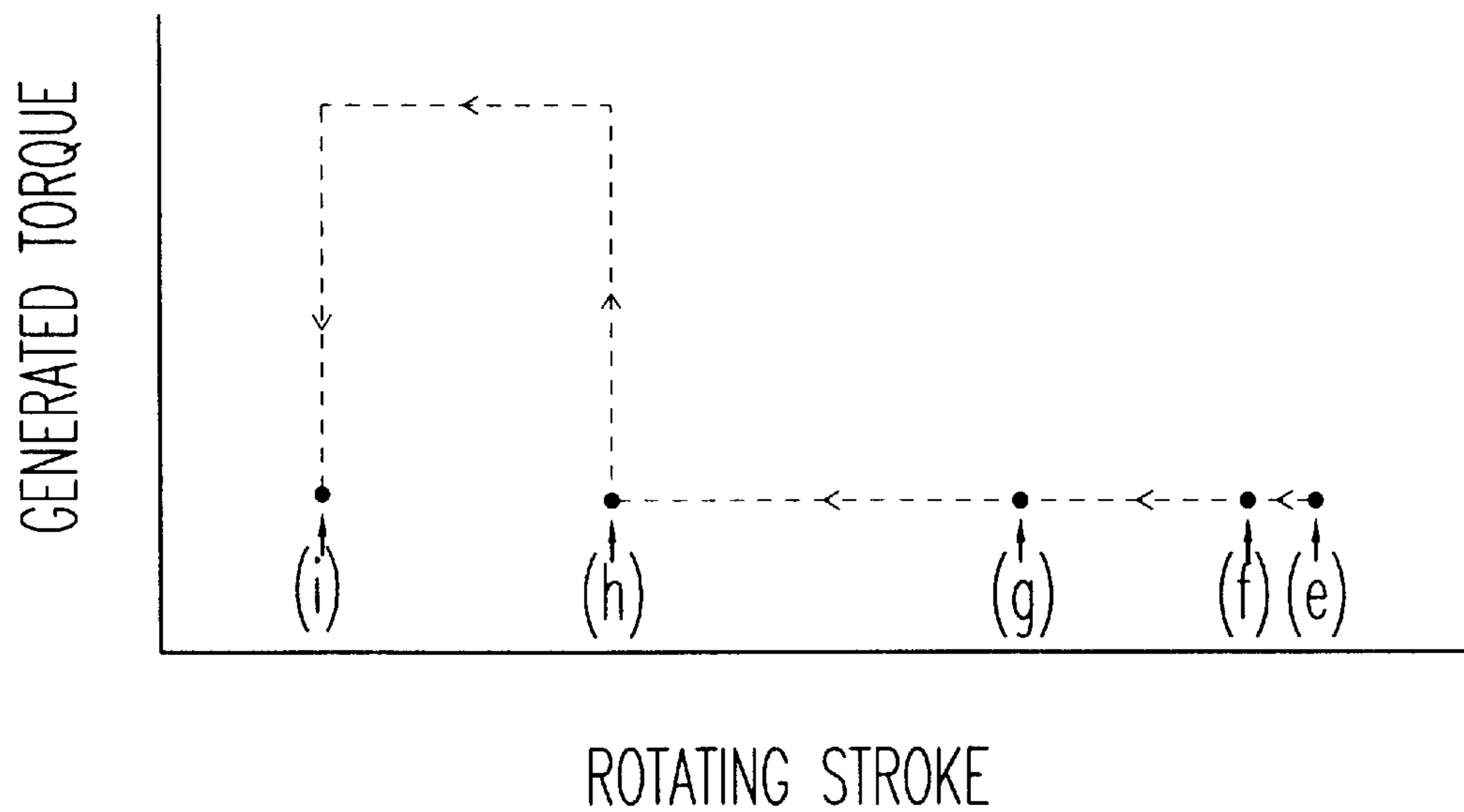

Fig. 12H

Fig. 12I



*Fig. 13*



*Fig. 14*

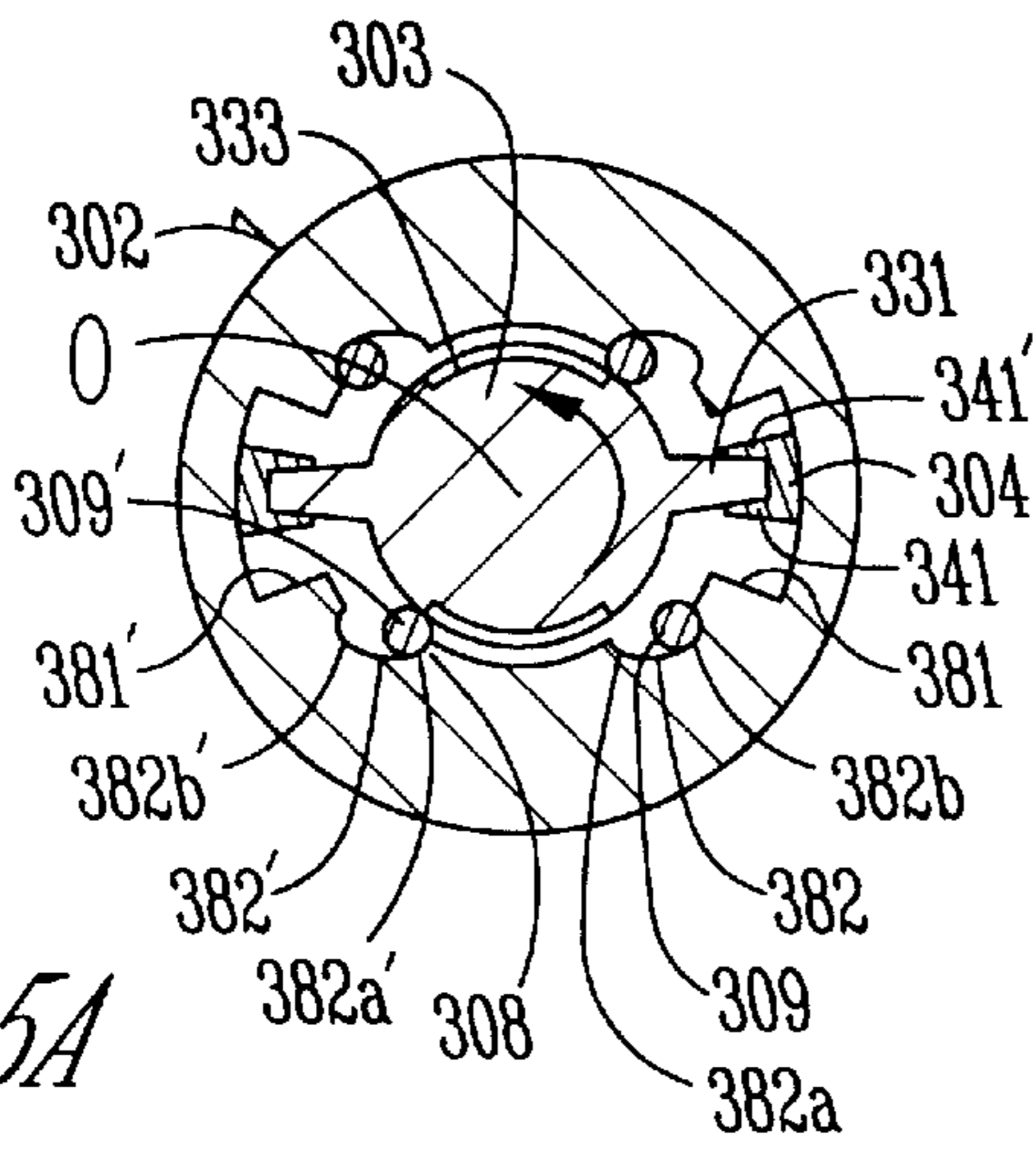

Fig. 15A

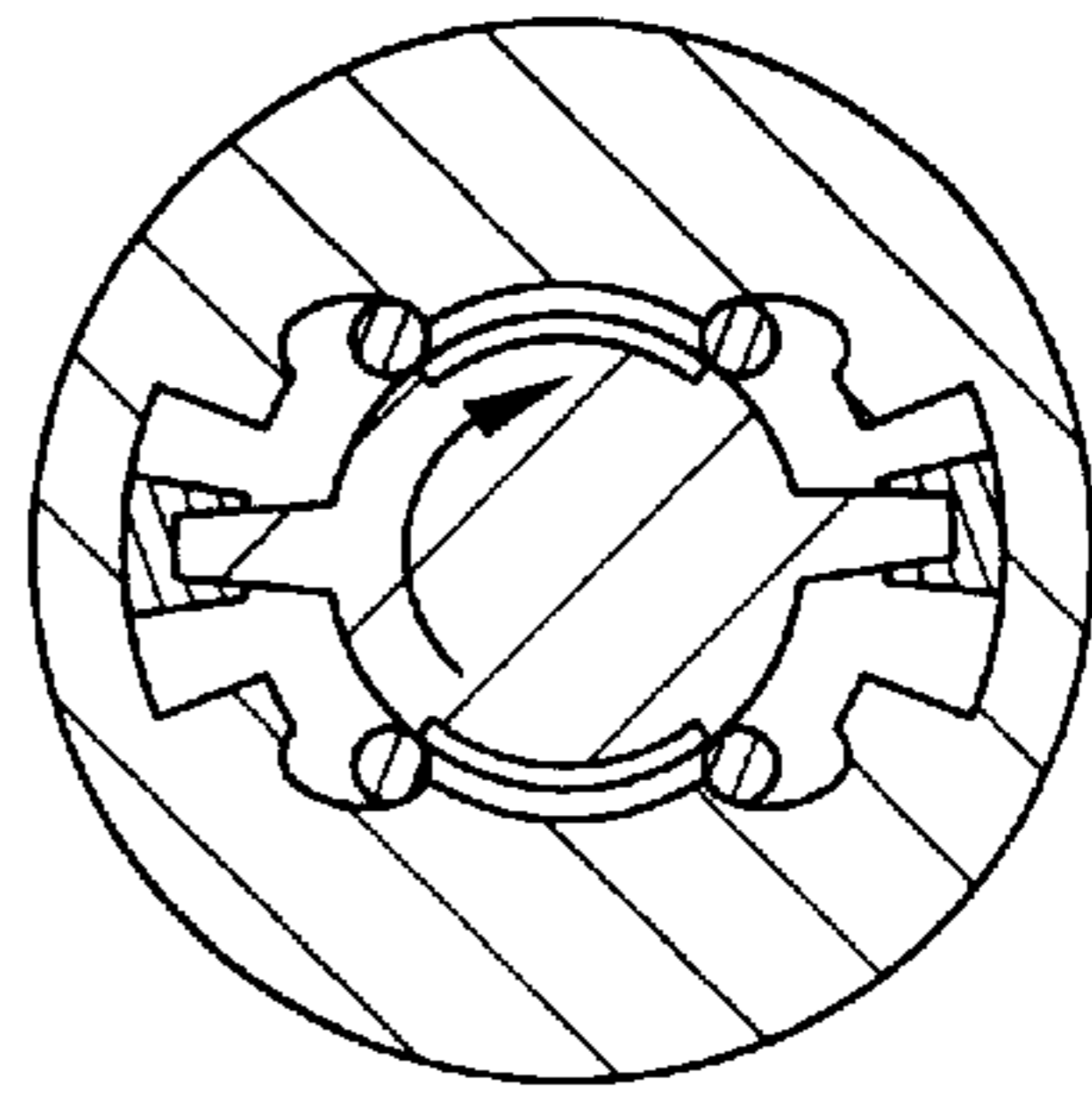

Fig. 15B

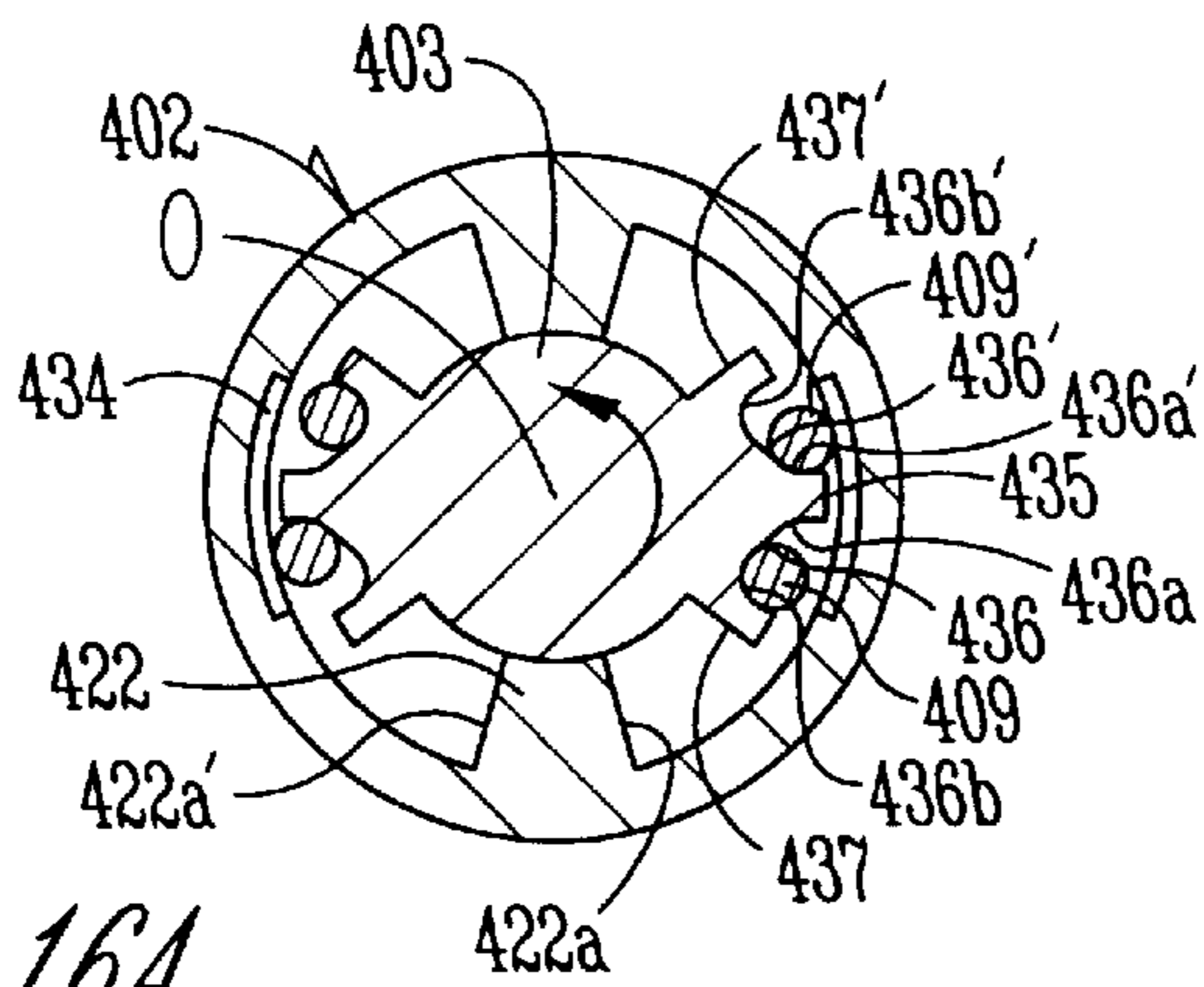

Fig. 16A

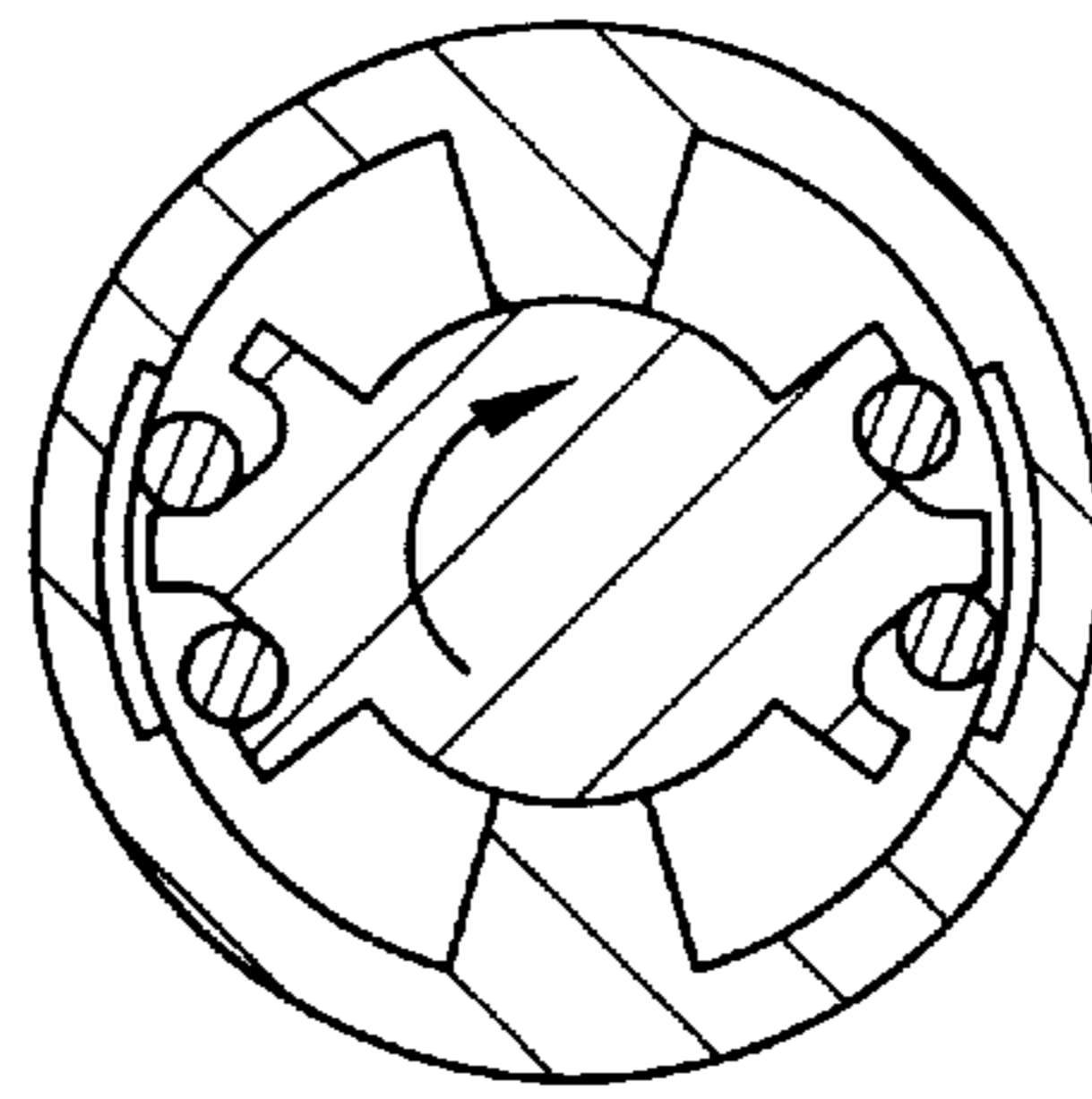

Fig. 16B

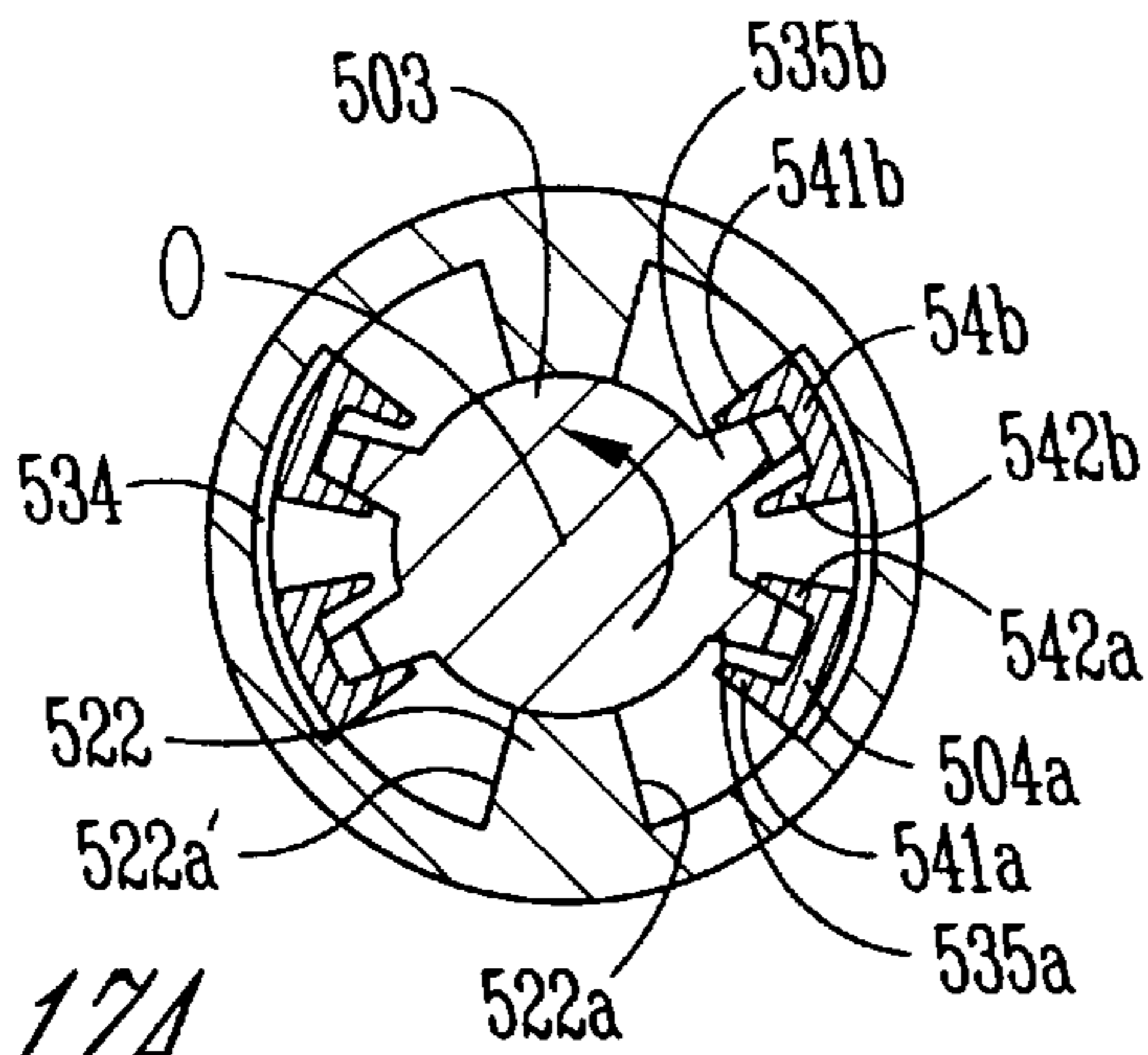

Fig. 17A

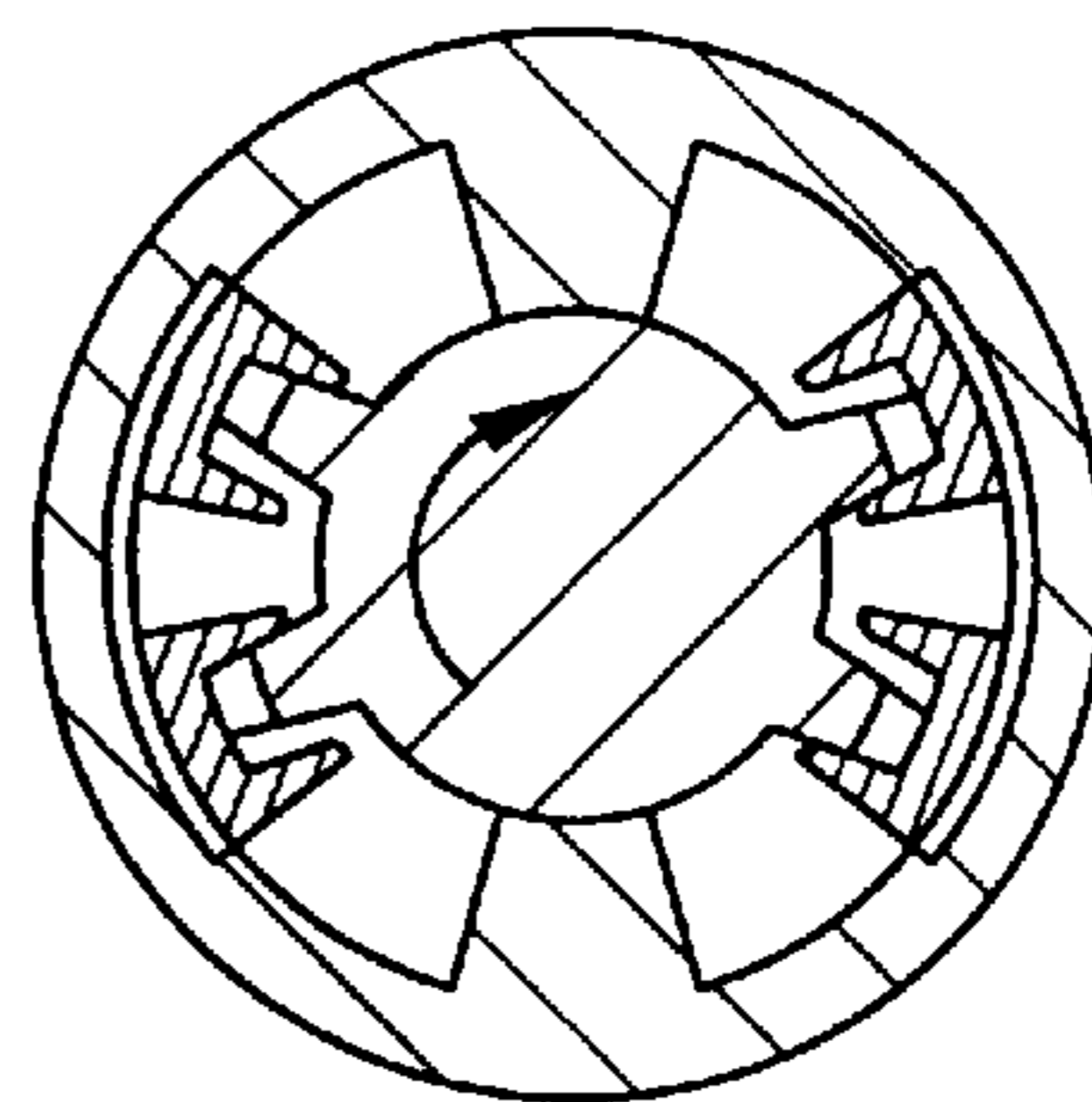

Fig. 17B

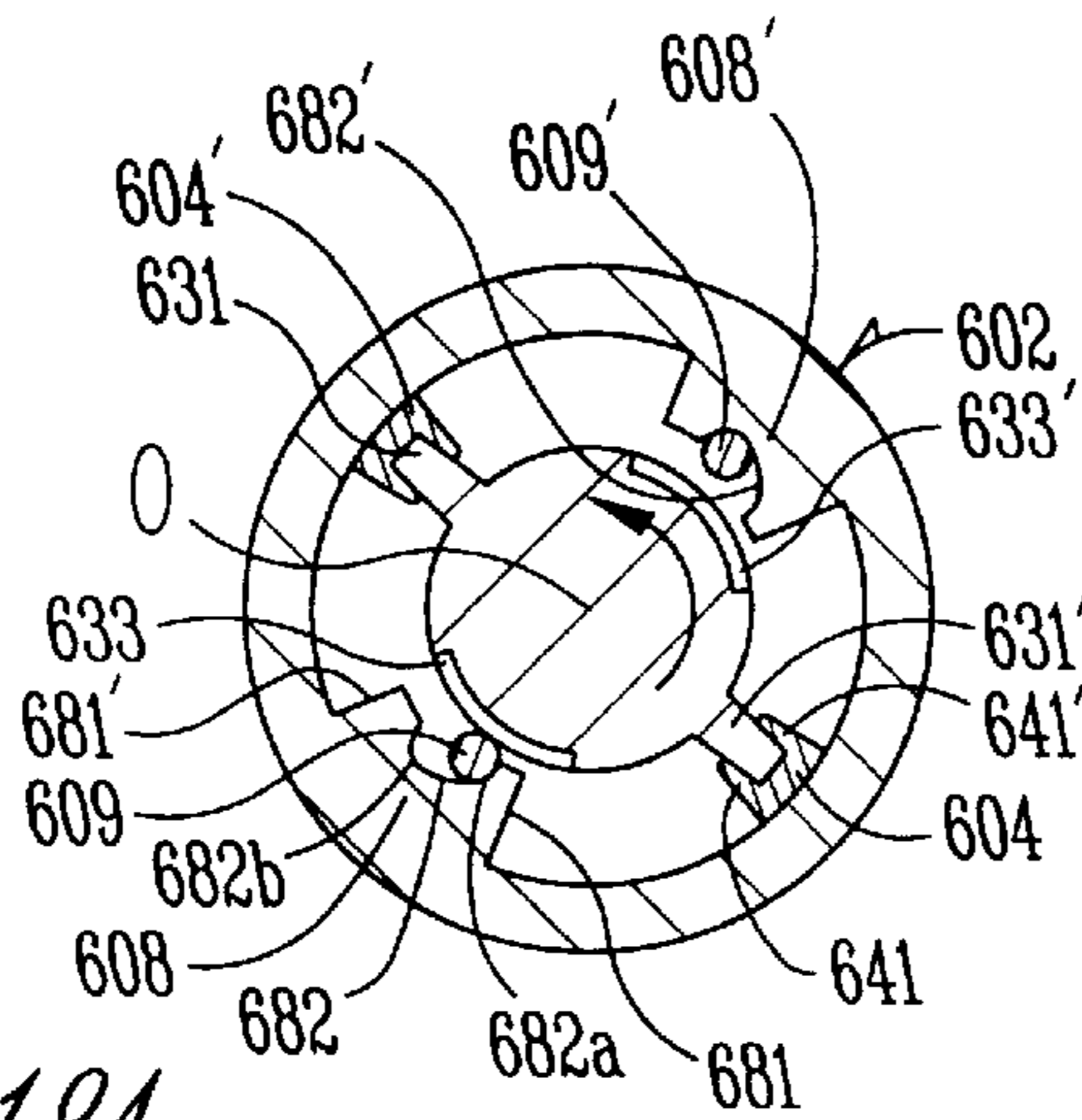

Fig. 18A

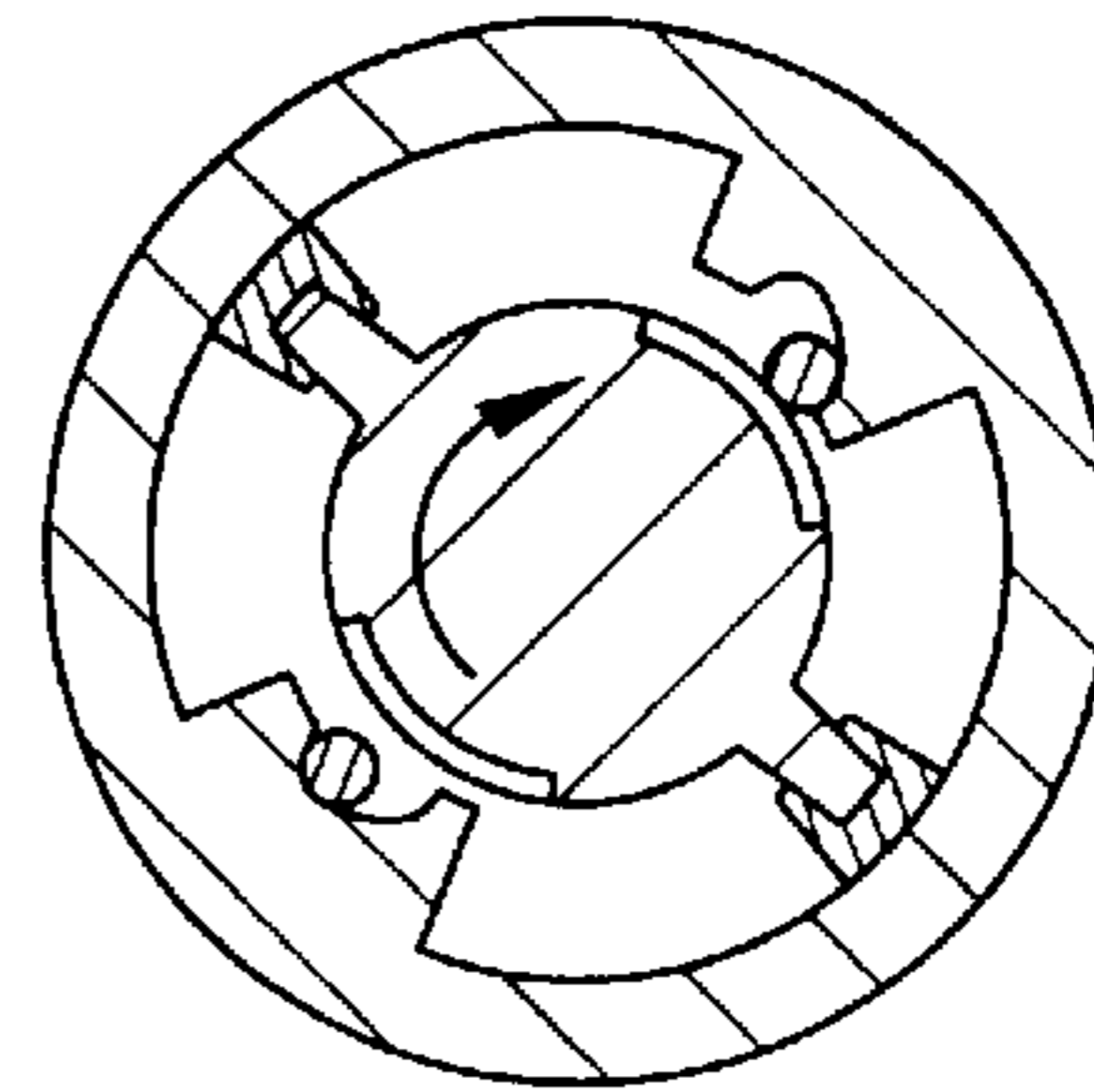

Fig. 18B

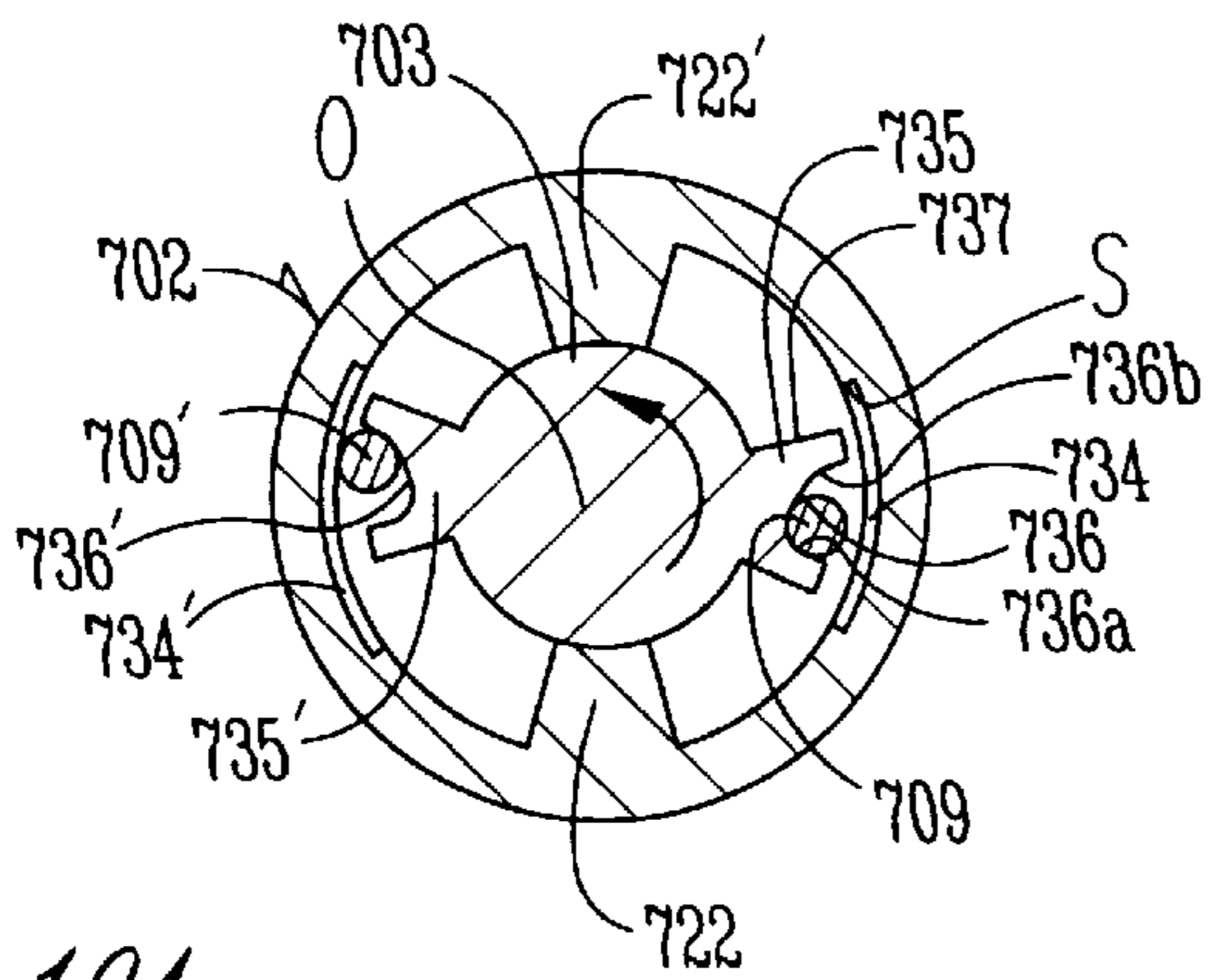

Fig. 19A

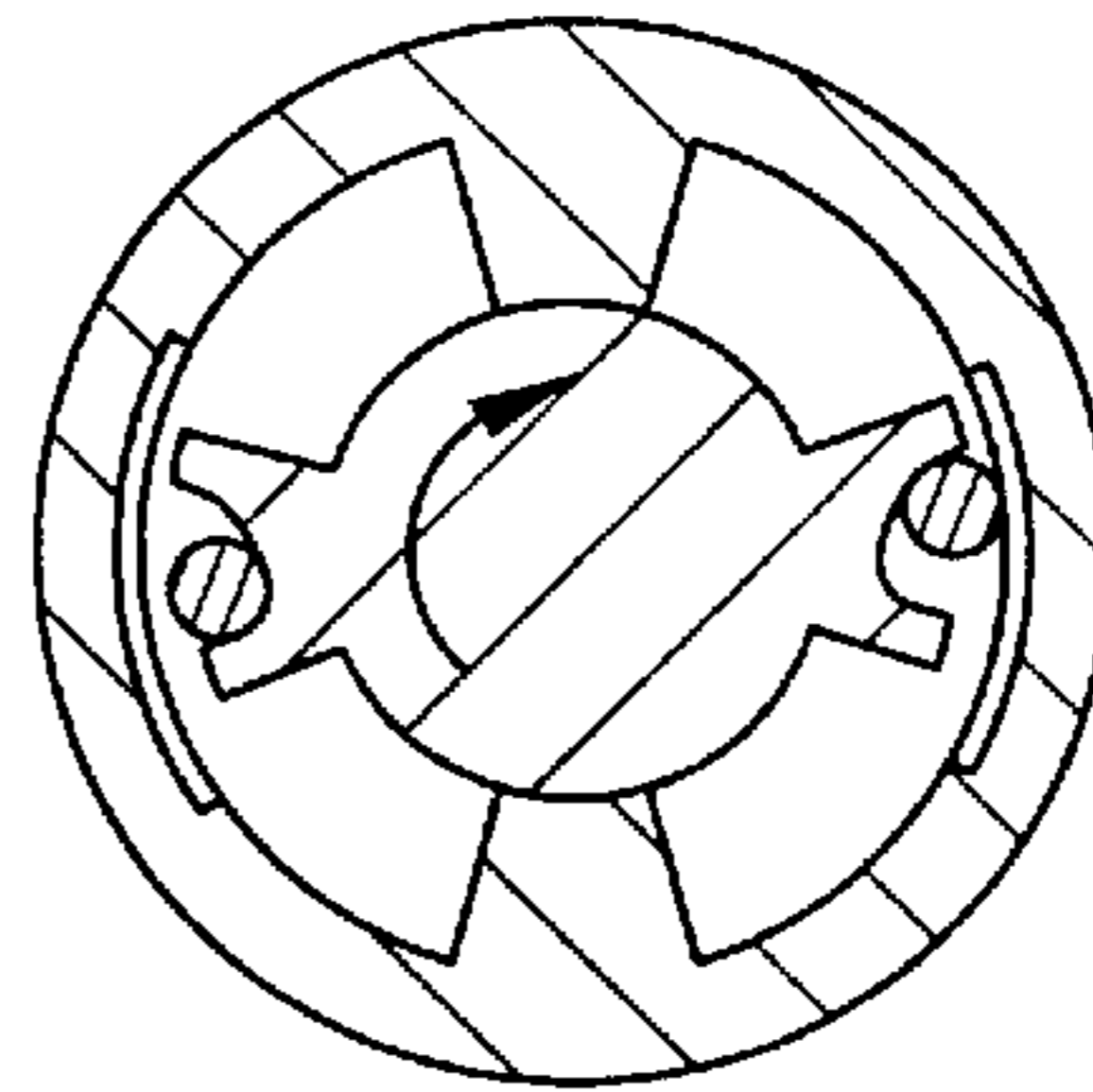

Fig. 19B

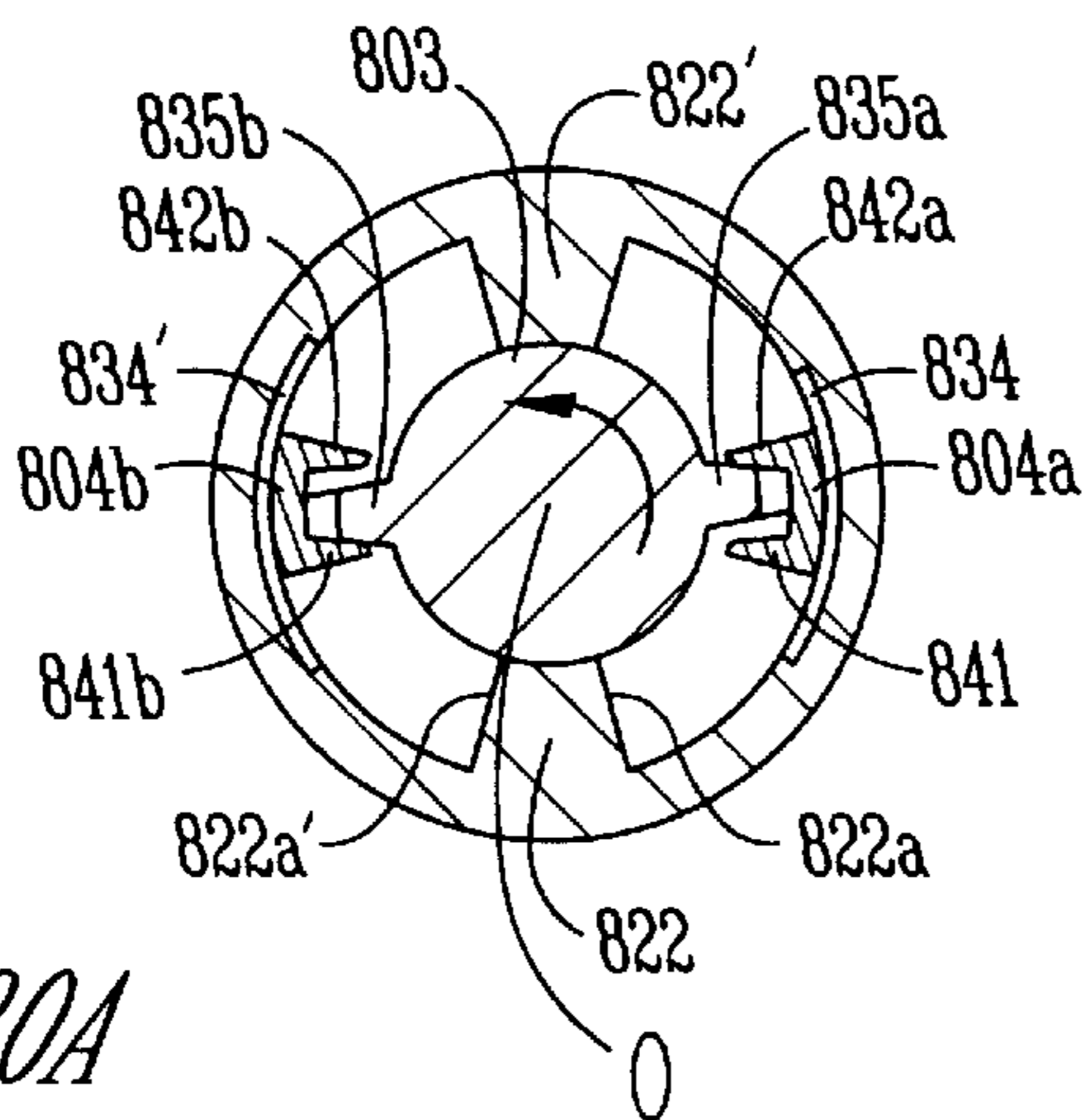

Fig. 20A

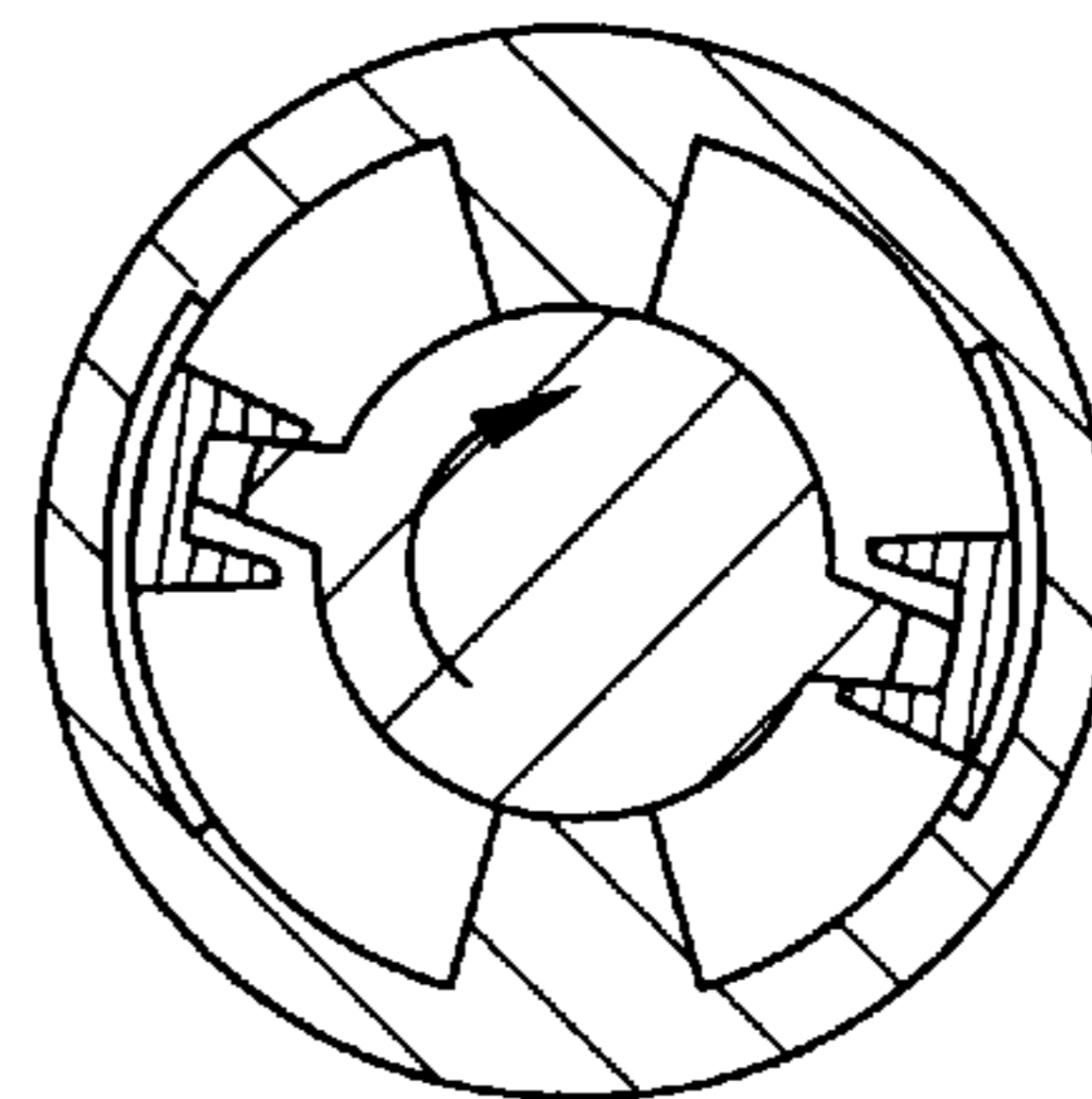

Fig. 20B

**DAMPER DEVICE****BACKGROUND OF THE INVENTION****1. Field of the Invention**

The present invention relates to a damper device for use on the door of a container to apply damping forces to the angular movement of the door in terminal ranges of opening and closing movements of the door, or for use on an electrically powered tool such as an electrically powered saw or plane to reduce shocks in terminal ranges of reciprocating movements thereof.

**2. Description of the Related Art**

Heretofore, some containers are equipped with a damper device mounted on the door for preventing the door from banging against the door frame when the door is closed. Since the damper device operates only when the door is closed, however, the damper device is not active when the door is quickly opened. When the door is quickly opened, therefore, the door tends to hit a stop, producing undesirable noise or causing damage to itself or the stop. For producing a damping action in a terminal range of the opening movement of the door, the door needs to incorporate another separate damper device separately from the existing damper device which operates only when the door is closed.

There has not been known any example in which the above damper device is applied to a reciprocally movable electrically powered tool. Heretofore, it has been customary for the user of a reciprocally movable electrically powered tool to empirically control forces produced by the tool in terminal regions of its reciprocating actions to avoid unwanted impacts or damage to the tool. However, controlling forces produced by the tool in terminal regions of its reciprocating actions needs a skilled experience on the part of the user, and is physically fatiguing to the user.

Installing two damper devices on one door is highly costly. In addition, it is a complex task to install two damper devices on one door and also to perform maintenance on the two damper devices mounted on the door. There has been a demand for a single damper device which is capable of producing a damping force in both terminal ranges of opening and closing movements of a door on which the damper device is installed.

**SUMMARY OF THE INVENTION**

It is therefore an object of the present invention to provide a damper device which is capable of generating a damping force in both terminal ranges of opening and closing movements or reciprocating movements of an apparatus on which the damper device is installed.

To achieve the above object, there is provided a damper device comprising a cylindrical casing, a rotor partly housed in the casing, a viscous fluid filled in the cylindrical casing around the rotor, and torque generating means for generating a torque during a rotating stroke of the rotor, the torque generating means including fluid torque adjusting means for producing a relatively large torque in a terminal range of each of the rotating strokes in normal and reverse directions of the rotor and a relatively small torque in other range of each of the rotating strokes. Therefore, if the damper device is installed on a door, then the damper device can produce a damping force in terminal periods of opening and closing movements of the door, thereby preventing the door from banging against a stopper or a door frame when the door is fully closed or opened. Furthermore, since the damper device generates a relatively small torque in the rotating

strokes in the normal and reverse directions, it is possible not to apply a damping force in a period other than the terminal periods of opening and closing movements of the door. As a result, the door can be opened and closed with a small force.

The torque generating means may have a first ridge extending axially on an outer surface of the rotor and having a radially outer surface held in sliding contact with an inner surface of the casing, and the fluid torque adjusting means may comprise a first land extending axially on the inner surface of the casing, a pair of first axial grooves defined axially in a radially inner end of the first land and spaced circumferentially from each other, a pair of first needle valves loosely fitted in the first axial grooves, respectively, for movement in the width direction of the first axial grooves, and a first circumferential groove defined circumferentially on the outer surface of the rotor, the first circumferential groove being positioned out of facing relation to at least one of the first needle valves in the terminal range of each of the rotating strokes. When the at least one of the needle valves is held against the outer surface of the rotor in the terminal range, the one of the first needle valves and the first ridge jointly divide an interior space of the casing into two chambers, for effectively preventing the viscous fluid from moving between the chambers to produce the relatively large torque. The fluid torque adjusting means of the above structure can easily be incorporated in the damper device, and can reliably generate a relatively large torque in the terminal range of each of the rotating strokes.

Alternatively, the torque generating means may have a second land extending axially on an inner surface of the casing and having a radially inner surface held in sliding contact with an outer surface of the rotor, and the fluid torque adjusting means may comprise a third land extending axially on the outer surface of the rotor, a pair of second axial grooves defined axially on a radially outer end of the third land on the rotor and spaced circumferentially from each other, a pair of second needle valves loosely fitted in the second axial grooves, respectively, for movement in the width direction of the second axial grooves, and a second circumferential groove defined circumferentially in the inner surface of the casing, the second cylindrical groove being positioned out of facing relation to at least one of the second needle valves in the terminal range of each of the rotating strokes. When the at least one of the second needle valves is held against the inner surface of the casing in the terminal range, the one of the second needle valves and the second land of the casing jointly divide an interior space of the casing into two chambers for effectively preventing the viscous fluid from moving between the chambers to produce the relatively large torque. The fluid torque adjusting means of the above structure can easily be incorporated in the damper device, and can reliably generate a relatively large torque in the terminal range of each of the rotating strokes.

Further alternatively, the torque generating means may have a fourth land extending axially on an inner surface of the casing and having a radially inner surface held in sliding contact with a outer surface of the rotor, and the fluid torque adjusting means may comprise a pair of second ridges extending axially on the outer surface of the rotor, a pair of valve bodies loosely mounted on the second ridges, respectively, and a third circumferential groove defined circumferentially in the inner surface of the casing, the third cylindrical groove being positioned out of facing relation to at least one of the needle valves in the terminal range of each of the rotating strokes. When the at least one of the valve bodies is held against the inner surface of the casing in the

terminal range, the one of the valve bodies and the second ridges jointly divide an interior space of the casing into two chambers for effectively preventing the viscous fluid from moving between the chambers to produce the relatively large torque. The fluid torque adjusting means of the above structure can easily be incorporated in the damper device, and can reliably generate a relatively large torque in the terminal range of each of the rotating strokes.

The above and other objects, features, and advantages of the present invention will become apparent from the following description when taken in conjunction with the accompanying drawings which illustrate preferred embodiments of the present invention by way of example.

#### BRIEF DESCRIPTION OF THE DRAWINGS

FIG. 1 is a cross-sectional view of a damper device according to a first embodiment of the present invention;

FIG. 2 is an enlarged exploded perspective view of a rotor of the damper device shown in FIG. 1;

FIG. 3 is an enlarged fragmentary perspective view of a cylindrical casing of the damper device shown in FIG. 1;

FIGS. 4A through 4I are cross-sectional view taking along line IV—IV of FIG. 1, showing the manner in which a fluid torque adjuster operates;

FIG. 5 is a cross-sectional view of a damper device according to a second embodiment of the present invention;

FIG. 6 is an enlarged fragmentary perspective view of a cylindrical casing of the damper device shown in FIG. 5;

FIG. 7 is an enlarged perspective view of a rotor of the damper device shown in FIG. 5;

FIGS. 8A through 8I are cross-sectional view taking along line VIII—VIII of FIG. 5, showing the manner in which a fluid torque adjuster operates;

FIG. 9 is a cross-sectional view of a damper device according to a third embodiment of the present invention;

FIG. 10 is an enlarged fragmentary perspective view of a cylindrical casing of the damper device shown in FIG. 9;

FIG. 11 is an enlarged exploded perspective view of a rotor of the damper device shown in FIG. 9;

FIGS. 12A through 12I are cross-sectional view taking along line XII—XII of FIG. 9, showing the manner in which a fluid torque adjuster operates;

FIG. 13 is a graph showing how a torque is generated when the rotor rotates in a normal direction;

FIG. 14 is a graph showing how a torque is generated when the rotor rotates in a reverse direction;

FIGS. 15A and 15B are cross-sectional views of a damper device according to a modification of the first embodiment;

FIGS. 16A and 16B are cross-sectional views of a damper device according to a modification of the second embodiment;

FIGS. 17A and 17B are cross-sectional views of a damper device according to a modification of the third embodiment;

FIGS. 18A and 18B are cross-sectional views of a damper device according to another modification of the first embodiment;

FIGS. 19A and 19B are cross-sectional views of a damper device according to another modification of the second embodiment; and

FIGS. 20A and 20B are cross-sectional views of a damper device according to another modification of the third embodiment.

#### DETAILED DESCRIPTION OF THE PREFERRED EMBODIMENTS

Like or corresponding parts are denoted by like or corresponding reference characters throughout views.

FIG. 1 through FIGS. 4A—4I show a damper device according to a first embodiment of the present invention.

As shown in FIG. 1, the damper device, generally denoted by the reference numeral 1, comprises a cylindrical casing 2, a rotor 3 having a portion rotatably mounted in the 2, and a viscous fluid 5 such as silicone oil filled in the casing 2 around the rotor 3. The casing 2 has a closed end 7 and an opposite open end fitted with an annular cap 6 having an opening 61 through which an axial protrusion 32 of the rotor 3 projects out of the casing 2. A sealing member 10 such as an O-ring is mounted between the rotor 3 and the cap 6 for preventing the viscous fluid 5 from leaking out of the casing 2 along the outer surface of the rotor 3. The casing 2 includes flanges 21 projecting radially outwardly from the open end thereof.

As shown in FIG. 2, the rotor 3 has an axial ridge 31 projecting radially outwardly from an outer surface thereof and fitted between circumferentially spaced radial walls 41, 41' of a spacer 4 which is of a substantially U-shaped cross section. The spacer 4 is placed on the radially outer end of the ridge 31 with substantially no play in circumferential and radial directions between the spacer 4 and the ridge 31. Substantially no play between the spacer 4 and the ridge 31 means that the spacer 4 is snugly mounted on the ridge 31 so that the spacer 4 will not wobble on the ridge 31, but the spacer 4 and the ridge 31 are not required to be dimensionally accurate as with precision parts.

When the rotor 3 rotates, the spacer 4 rotates in unison with the ridge 31 with a very small clearance present between the outer circumferential surface of the spacer 4 and the inner surface of the casing 2.

The spacer 4 may be integrally formed with the ridge 31 of the rotor 3.

As shown in FIG. 2, the rotor 3 has a first groove 33 defined in the outer surface thereof at an axially intermediate position, the first groove 33 having a constant width and depth and extending from a starting end S to a terminal end E. The starting end S is spaced circumferentially a given distance from the ridge 31. The groove 33 extends circumferentially from the starting end S away from the ridge 31 to the terminal end E at a position that is diametrically opposite to the starting end S and which is spaced a given distance from the ridge 31. The groove 33 angularly extends about 190° around the central axis O (FIG. 1) of the rotor 3. The width and depth of the groove 33 may be varied circumferentially and/or axially to obtain a desired torque from the damper device 1.

As shown in FIG. 3, the cylindrical casing 2 has an axial land 8 projecting radially inwardly from the inner surface thereof and angularly extends about 130° around the central axis O (FIG. 1) of the casing 2 which is aligned with the central axis O of the rotor 3. When the rotor 3 rotates, the spacer 4 also rotates until it abuts against one of circumferentially opposite ends 81, 81' of the land 8, whereupon the rotor 3 is stopped against rotation.

It is more preferable to stop the rotation of the rotor 3 with stoppers positioned outside of the damper device 1 before the spacer 4 abuts against one of circumferentially opposite ends 81, 81' because use of such stoppers is effective in increasing the durability of the spacer 4 and the land 8.

The land 8 has a pair of axial grooves 82, 82', and needle valves 9, 9' having smaller diameters than the widths of the axial grooves 82, 82' are loosely fitted in the axial grooves 82, 82', respectively. The groove 82 has a depth progressively greater circumferentially toward the end 81, and the groove 82' has a depth progressively greater circumferen-

tially toward the end **81'**. The needle valves **9, 9'** are movable between shallowest groove portions **82a, 82a'** of the grooves **82, 82'** and deepest groove portions **82b, 82b'** of the grooves **82, 82'**.

As shown in FIGS. **4B** through **4E**, when the rotor **3** rotates counterclockwise with respect to the casing **2**, the needle valve **9** is positioned in the deepest groove portion **82b**, and the needle valve **9'** is positioned in the shallowest groove portion **82a'**. As shown in FIGS. **4F** through **4I**, when the rotor **3** rotates clockwise with respect to the casing **2**, the needle valve **9** is positioned in the shallowest groove portion **82a**, and the needle valve **9'** is positioned in the deepest groove portion **82b'**.

While the needle valve **9** or **9'** is being positioned in the shallowest groove portion **82a** or **82a'**, when the needle valve **9** or **9'** face the groove **33** in the rotor **3**, a clearance which is as deep as the groove **33** is present between the needle valve **9** or **9'** and the rotor **3**, and when the needle valve **9** or **9'** does not face the groove **33**, the needle valve **9** or **9'** contact the outer surface of the rotor **3**.

While the needle valve **9** or **9'** is being positioned in the deepest groove portion **82b** or **82b'**, when the needle valve **9** or **9'** face the groove **33** in the rotor **3**, a clearance which is deeper than the groove **33** is present between the needle valve **9** or **9'** and the rotor **3**.

The damper device **1** is installed on a container or the like as follows: The flanges **21** of the casing **2** are fastened to a container body such as a frame for the door of the container. The door is pivotally supported on the container body by a hollow shaft or the like. The protrusion **32** of the rotor **3** is fitted in the hollow shaft and lockingly secured to the hollow shaft, so that the rotor **3** is coupled to the door by the hollow shaft.

Conversely, the flanges **21** may be fastened to the door of the container, and protrusion **32** of the rotor **3** may be fitted in a hollow shaft mounted on a container body such as a frame for the door of the container, and lockingly secured to the hollow shaft, so that the rotor **3** is coupled to the door by the hollow shaft.

According to the first embodiment as described above, a fluid torque adjuster comprises the needle valves **9, 9'** disposed axially on the inner surface of the casing **2**, and the first groove **33** defined circumferentially in the outer surface of the rotor **3**.

Operation of the fluid torque adjuster according to the first embodiment will be described below with reference to FIGS. **4A** through **4I**. First, an action of the fluid torque adjuster when the door of the container is closed from a fully open, still position will be described below.

When the door of the container with the damper device **1** mounted thereon is fully open, the parts of the damper device **1** are in the position shown in FIG. **4A**. The wall **41** of the spacer **4** mounted on the ridge **31** is held against the end **81** of the land **8**. Since the viscous fluid does not flow at this stage, the needle valves **9, 9'** are in a free state in the respective grooves **82, 82'**.

When the rotor **3** slightly rotates counterclockwise from the position shown in FIG. **4A**, the needle valve **9** moves counterclockwise into the deepest groove portion **82b** and the needle valve **9'** moves counterclockwise into the shallowest groove portion **82a'** as shown in FIG. **4B**.

As the rotor **3** rotates from the position shown in FIG. **4B** to the position shown in FIG. **4C**, the needle valve **9** is positioned in the deepest groove portion **82b** though it does not face the groove **33**. Therefore, a passage for the viscous

fluid **5** is provided between opposite sides of the needle valve **9**. Inasmuch as the needle valve **9'** faces the groove **33**, a passage for the viscous fluid **5** is also provided between opposite sides of the needle valve **9'**. Since passages for the viscous fluid **5** are thus provided between opposite sides of the needle valves **9, 9'**, the fluid torque adjuster generates a relatively small torque.

When the rotor **3** rotates from the position shown in FIG. **4C** to the position shown in FIG. **4D**, the needle valve **9'** positioned in the shallowest groove **82a'** passes the terminal end **E** of the groove **33** and contact the surface of the rotor **3**. Therefore, as the passages for the viscous fluid **5** between opposite sides of the needle valve **9'** is interrupted, the fluid torque adjuster generates a relatively large torque.

When the rotor **3** further rotates counterclockwise from the position shown in FIG. **4D**, the other wall **41'** of the spacer **4** abuts against the other end **81'** of the land **8** as shown in FIG. **4E**, whereupon the rotor **3** is stopped against rotation. While the rotor **3** is rotating from the position shown in FIG. **4D** to the position shown in FIG. **4E**, the needle valve **9'** does not face the groove **33** and is positioned in the shallowest groove portion **82a'**, and hence is in contact with the outer surface of the rotor **3**. Since no passage for the viscous fluid **5** is provided between opposite sides of the needle valve **9'**, the fluid torque adjuster generates a relatively large torque.

Consequently, when the door of the container is closed from the fully open position, the fluid torque adjuster generates a relatively large torque in a terminal range of the rotating stroke of the rotor **3**, and generates a relatively low torque from a starting range of the rotating stroke of the rotor **3** prior to the terminal range of the rotating stroke thereof.

Now, an action of the fluid torque adjuster when the door of the container is opened from a fully closed position will be described below.

When the door of the container with the damper device **1** mounted thereon is fully closed, the parts of the damper device **1** are in the position shown in FIG. **4E**.

When the rotor **3** slightly rotates clockwise from the position shown in FIG. **4E**, the needle valve **9** moves clockwise from the deepest groove portion **82b** into the shallowest groove portion **82a** and the needle valve **9'** moves clockwise from the shallowest groove portion **82a'** into the deepest groove portion **82b'** as shown in FIG. **4F**.

As the rotor **3** rotates from the position shown in FIG. **4F** to the position shown in FIG. **4G**, the needle valve **9'** is still positioned in the deepest groove portion **82b'** while not facing the groove **33**, and the needle valve **9** faces the groove **33**. Therefore, the passages for the viscous fluid **5** are thus kept between opposite sides of the needle valves **9, 9'**, and the fluid torque adjuster generates a relatively small torque.

When the rotor **3** rotates from the position shown in FIG. **4G** to the position shown in FIG. **4H**, the needle valve **9** positioned in the shallowest groove **82a** passes the starting end **S** of the groove **33** and contact the circumferential surface of the rotor **3**, while the needle valve **9'** faces the groove **33**. Therefore, as the passages for the viscous fluid **5** between opposite sides of the needle valves **9** is thus interrupted, the fluid torque adjuster generates a relatively large torque.

As the rotor **3** further rotates from the position shown in FIG. **4H**, when the wall **41** of the spacer **4** abuts against the end **81** of the land **8** as shown in FIG. **4I**, whereupon the rotor **3** is stopped against rotation.

As the rotor **3** rotates from the position shown in FIG. **4H** up to the position shown in FIG. **4I**, the needle valve **9'** is



positioned in the deepest groove portion **82b'** while facing the groove **33**. Therefore, the clearance is still kept between the needle valve **9'** and the rotor **3**. However, the needle valve **9** is no longer facing the groove **33** and contacts the outer surface of the rotor **3**. Since no passage for the viscous fluid **5** is produced between opposite sides of the needle valve **9**, the fluid torque adjuster generates a relatively large torque.

Consequently, when the door of the container is opened from the fully closed position, the fluid torque adjuster generates a relatively large torque in a terminal range of the rotating stroke of the rotor **3**, and generates a relatively low torque from a starting range prior to the terminal range of the rotating stroke thereof, as when the door of the container is closed from the fully open position.

A damper device according to a second embodiment of the present invention will be described below with reference to FIGS. **5** through **8A–8I**.

As shown in FIG. **5**, the damper device, generally denoted by the reference numeral **101**, comprises a cylindrical casing **102**, a rotor **103** having a portion rotatably mounted in the casing **102**, and a viscous fluid **105** filled in the casing **102** around the rotor **103**. An axial protrusion **132** of the rotor **103** projects out of an opening **161** in an annular cap **106** in the open end of the casing **102**. A sealing member **110** prevents the viscous fluid **105** from leaking out of the casing **102**.

As shown in FIG. **6**, the casing **102** has a first land **122** projecting radially inwardly from an inner surface thereof. When the rotor **103** rotates, the outer surface of the rotor **103** slides against a radially inner surface of the land **122**. When a second land **135** (described later on) of the rotor **103** abuts against one of circumferentially opposite ends **122a**, **122a'** of the land **122**, the rotor **103** is stopped against rotation.

As shown in FIG. **6**, the casing **102** has a second groove **134** defined in the inner surface thereof, the second groove **134** having a constant width and depth and extending from a starting end **S** to a terminal end **E**. The second groove **134** extends diametrically opposite to the land **122**. Specifically, the distance between the starting end **S** and the end **122a** is equal to the distance between the terminal end **E** and the other end **122a'**. Alternatively, the distance between the starting end **S** and the end **122a** may be different from the distance between the terminal end **E** and the other end **122a'**. The groove **134** angularly extends about  $140^\circ$  around the central axis **O** (FIG. **5**) of the casing **102**. The width and depth of the groove **134** may be varied circumferentially and/or axially to obtain a desired torque from the damper device **101**.

As shown in FIG. **7**, the rotor **103** has a second land **135** extending axially on the outer surface thereof. The land **135** has a pair of axial grooves **136**, **136'** defined in an outer surface thereof, and also has a pair of circumferentially opposite ends **137**, **137'**. The land **135** angularly extends about  $80^\circ$  around the central axis **O** (FIG. **5**) of the rotor **103**. Needle valves **109**, **109'** having smaller diameters than the widths of the axial grooves **136**, **136'** are loosely fitted in the axial grooves **136**, **136'**, respectively. The groove **136** has a depth progressively greater circumferentially toward the end **137**, and the groove **136'** has a depth progressively greater circumferentially toward the end **137'**. The needle valves **109**, **109'** are movable between shallowest groove portions **136a**, **136a'** and deepest groove portions **136b**, **136b'** of the grooves **136**, **136'**.

As shown in FIGS. **8B** through **8E**, when the rotor **103** rotates counterclockwise with respect to the casing **102**, the

needle valve **109** is positioned in the deepest groove portion **136b**, and the needle valve **109'** is positioned in the shallowest groove portion **136a'**. As shown in FIGS. **8F** through **8I**, when the rotor **103** rotates clockwise with respect to the casing **102**, the needle valve **109** is positioned in the shallowest groove portion **136a**, and the needle valve **109'** is positioned in the deepest groove portion **136b'**.

While the needle valve **109** or **109'** is being positioned in the shallowest groove portion **136a** or **136a'**, when the needle valve **109** or **109'** face the groove **134** in the casing **102**, a clearance which is as deep as the groove **134** is created between the needle valve **109** or **109'** and the casing **102**, and when the needle valve **109** or **109'** does not face the groove **134**, the needle valves **109** or **109'** contact the inner surface of the casing **102**.

While the needle valve **109** or **109'** is being positioned in the deepest groove portion **136b** or **136b'**, when the needle valve **109** or **109'** faces the groove **134** in the casing **102**, a clearance which is deeper than the groove **134** is created between the needle valve **109** or **109'** and the casing **102**.

According to the second embodiment as described above, a fluid torque adjuster comprises the grooves **136**, **136'** defined axially in the land **135** on the outer surface of the rotor **103**, and the second groove **134** defined circumferentially in the inner surface of the casing **102**.

The damper device **101** according to the second embodiment is connected to the door of a container or the like as with the damper device according to the first embodiment.

Operation of the fluid torque adjuster according to the second embodiment will be described below with reference to FIGS. **8A** through **8I**. First, an action of the fluid torque adjuster when the door of the container is closed from a fully open position will be described below.

When the door of the container with the damper device **101** mounted thereon is fully open, the parts of the damper device **101** are in the position shown in FIG. **8A**. The end **137** of the land **135** is held against the end **122a** of the land **122**. Since the viscous fluid does not flow at this stage, the needle valves **109**, **109'** are in a free state in the respective grooves **136**, **136'**.

When the rotor **103** slightly rotates counterclockwise from the position shown in FIG. **8A** to the position shown in FIG. **8B**, the needle valve **109** moves clockwise into the deepest groove portion **136b** and the needle valve **109'** moves clockwise into the shallowest groove portion **136a'**.

As the rotor **103** rotates from the position shown in FIG. **8B** to the position shown in FIG. **8C**, the needle valve **109** is positioned in the deepest groove portion **136b** though it does not face the groove **134**. Therefore, a passage for the viscous fluid **105** is provided between opposite sides of the needle valve **109**. Inasmuch as the needle valve **109'** faces the groove **134** a passage for the viscous fluid **105** is also provided between opposite sides of the needle valve **109'**, and as a result, the fluid torque adjuster generates a relatively small torque.

When the rotor **103** rotates from the position shown in FIG. **8C** to the position shown in FIG. **8D**, the needle valve **109'** positioned in the shallowest groove **136a'** comes to the terminal end **E** of the groove **134** and contacts the inner surface of the casing **102** while the needle valve **109** faces the groove **134**. Therefore, since the passages for the viscous fluid **105** between opposite sides of the needle valve **109'** is thus interrupted, the fluid torque adjuster generates a relatively large torque.

When the rotor **103** further rotates counterclockwise from the position shown in FIG. **8D**, the other end **137'** of the land

**135** abuts against the other end **122a'** of the land **122** as shown in FIG. **8E**, whereupon the rotor **103** is stop against rotation. While the rotor **103** is rotating from the position shown in FIG. **8D** to the position shown in FIG. **8E**, the needle valve **109'** does no longer face the groove **134** and is positioned in the shallowest groove portion **136a'**, and hence is in contact with the inner surface of the casing **102**. Since no passage for the viscous fluid **105** is provided between opposite sides of the needle valve **109'**, the fluid torque adjuster generates a relatively large torque.

Consequently, when the door of the container is closed from the fully open position, the fluid torque adjuster generates a relatively large torque in a terminal range of the rotating stroke of the rotor **103**, and generates a relatively low torque from a starting range of the rotating stroke of the rotor **103** prior to the terminal range of the rotating stroke thereof.

Now, an action of the fluid torque adjuster when the door of the container is opened from a fully closed position will be described below.

When the door of the container with the damper device **101** mounted thereon is fully closed, the parts of the dapper device **101** are in the position shown in FIG. **8E**.

When the rotor **103** slightly rotates clockwise from the position shown in FIG. **8E**, the needle valve **109** moves counterclockwise from the deepest groove portion **136b** into the shallowest groove portion **136a** and the needle valve **109'** moves counterclockwise from the shallowest groove portion **136a'** into the deepest groove portion **136b'** as shown in FIG. **8F**.

As the rotor **103** rotates from the position shown in FIG. **8F** to the position shown in FIG. **8G**, the needle valve **109'** is still positioned in the deepest groove portion **136b'** while not facing the groove **134**, and the needle valve **109** faces the groove **134**. Therefore, the passages for the viscous fluid **105** are thus kept between opposite sides of the needle valves **109, 109'**, the fluid torque adjuster generates a relatively small torque.

When the rotor **103** rotates from the position shown in FIG. **8G** to the position shown in FIG. **8H**, the needle valve **109** positioned in the shallowest groove **136a** comes to the starting end **S** of the groove **134** and contacts the inner surface of the casing **102** while the needle valve **109'** faces the groove **134**. Therefore, as the passages for the viscous fluid **105** between opposite sides of the needle valve **109** is thus interrupted, the fluid torque adjuster generates a relatively large torque.

As the rotor **103** further rotates from the position shown in FIG. **8H**, when the end **137** of the land **135** abuts against the end **122a** of the land **122** as shown in FIG. **8I**, whereupon the rotor **103** is stopped against rotation. In the position shown in FIG. **8I**, the needle valves **109, 109'** are in the initial free state as shown in FIG. **8A**.

As the rotor **103** rotates from the position shown in FIG. **8H** up to the position shown in FIG. **8I**, the needle valve **109'** is positioned in the deepest groove portion **136b'** while facing the groove **134**. Therefore, the clearance is still kept between the needle valve **109'** and the casing **102**. However, the needle valve **109** positioned in the shallowest groove portion **136a** is no longer facing the groove **134** and contacts the inner surface of the casing **102**. Since no passage for the viscous fluid **105** is provided between opposite sides of the needle valve **109**, the fluid torque adjuster continues to generate a relatively large torque.

Consequently, according to the second embodiment, as with the first embodiment, when the door of the container is

opened from the fully closed position, the fluid torque adjuster generates a relatively large torque in a terminal range of the rotating stroke of the rotor **103**, and generates a relatively low torque from a starting range prior to the terminal range of the rotating stroke thereof, as when the door of the container is closed from the fully open position.

A damper device according to a third embodiment of the present invention will be described below with reference to FIG. **9** through **12A–12I**.

As shown in FIG. **9**, the dapper device, generally denoted by the reference numeral **201**, comprises a cylindrical casing **202**, a rotor **203** having a portion rotatably mounted in the casing **202**, and a viscous fluid **205** filled in the casing **202** around the rotor **203**. An axial protrusion **232** of the rotor **203** projects out of an opening **261** in an annular cap **206** in the open end of the casing **202**. A sealing member **210** prevents the viscous fluid **205** from leaking out of the casing **202**.

As shown in FIG. **10**, the casing **202** has a land **222** projecting radially inwardly from an inner surface thereof. When the rotor **203** rotates, the outer surface of the rotor **203** slides against a radially inner surface of the land **222**. When the rotor **203** rotates clockwise in FIGS. **12F–12H**, an end **241a** of a valve body **204a** abuts against an end **222a** of the land **222**, whereupon the rotor **203** is stopped against rotation. When the rotor **203** rotates counterclockwise in FIGS. **12B–12D**, an end **241b** of a valve body **204b** abuts against an opposite end **222a'** of the land **222**, whereupon the rotor **203** is stopped against rotation.

As shown in FIG. **10**, the casing **202** has a third groove **234** defined in the inner surface thereof, the third groove **234** having a constant width and depth and extending from a starting end **S** to a terminal end **E**. The third groove **234** extends diametrically opposite to the land **222**. Specifically, the distance between the starting end **S** and the end **222a** is equal to the distance between the terminal end **E** and the other end **222a'**. Alternatively, the distance between the starting end **S** and the end **222a** may be different from the distance between the terminal end **E** and the other end **222a'**. The groove **234** angularly extends about  $190^\circ$  around the central axis **O** of the casing **202**. The width and depth of the groove **234** may be varied circumferentially and/or axially to obtain a desired torque from the damper device **201**.

As shown in FIG. **11**, the rotor **203** has a pair of circumferentially spaced axial ridges **235a, 235b** projecting radially outwardly from an outer surface thereof and having respective recesses **p, q** defined axially centrally in radially outer ends thereof. The ridges **235a, 235b** extend respectively along planes angularly spaced about  $50^\circ$  from each other about the central axis **O** of the rotor **203**.

Valve bodies **204a, 204b**, each of a substantially U-shaped cross section, are loosely fitted over the respective ridges **235a, 235b** for rotation with the ridges **235a, 235b** upon rotation of the rotor **203**. The valve body **204a** has a pair of circumferentially spaced radial walls **241a, 242a**, and the valve body **204b** has a pair of circumferentially spaced radial walls **241b, 242b**. The circumferential distance between the walls **241a, 242a** and the circumferential distance between the walls **241b, 242b** are greater than the circumferential widths of the ridges **235a, 235b**. Therefore, the ridges **235a, 235b** can move between the walls **241a, 242a** and between the walls **241b, 242b**.

The walls **242a, 242b** which are positioned adjacent to each other have respective recesses **r, s** defined axially centrally therein. The walls **241a, 241b** have no such recesses.

As shown in FIGS. 12B through 12E, when the rotor 203 rotates counterclockwise with respect to the casing 202, the ridge 235a rotates with its forward face held against the wall 242a of the valve body 204a, and the ridge 235b rotates with its forward face held against the wall 241b of the valve body 204b. As shown in FIGS. 12F through 12I, when the rotor 203 rotates clockwise with respect to the casing 202, the ridge 235a rotates with its forward face held against the wall 241a of the valve body 204a, and the ridge 235b rotates with its forward face held against the wall 242b of the valve body 204b.

According to the third embodiment, a fluid torque adjuster comprises the valve bodies 204a, 204b loosely fitted over the respective ridges 235a, 235b, and the third groove 234 defined circumferentially in the inner surface of the casing 202. The valve bodies 204a, 204b include the radial walls 242a, 242b, respectively, each having a recess and the radial walls 241a, 241b, respectively, each having no recess.

The damper device 201 according to the third embodiment is connected to the door of a container or the like as with the damper devices according to the first and second embodiments.

Operation of the fluid torque adjuster according to the third embodiment will be described below with reference to FIGS. 12A through 12I. First, an action of the fluid torque adjuster when the door of the container is closed from a fully open position will be described below.

When the door of the container with the damper device 201 mounted thereon is fully open, the parts of the damper device 201 are in the position shown in FIG. 12A. The wall 241a of the valve body 204a has an inner surface held against the lower surface, as shown in FIG. 12A, of the ridge 235a, and an outer surface held against the end 222a of the land 222. The radially outer surface of the valve body 204a is held against the inner surface of the casing 202. The wall 242b of the valve body 204b has an inner surface held against the lower surface, as shown in FIG. 12A, of the ridge 235b. The radially outer surface of the valve body 204b faces the groove 234. A clearance which is as deep as the groove 234 is present between the radially outer surface of the valve body 204b and the inner surface of the casing 202.

When the rotor 203 slightly rotates counterclockwise from the position shown in FIG. 12A to the position shown in FIG. 12B, the valve bodies 204a, 204b do not rotate until the inner surface of the wall 242a of the valve body 204a is brought into contact with the upper surface, as shown in FIG. 12B, of the ridge 235a, and the inner surface of the wall 241b of the valve body 204b is brought into contact with the upper surface, as shown in FIG. 12B, of the ridge 235b.

In the position shown in FIG. 12B, as with the position shown in FIG. 12A, the radially outer surface of the valve body 204a is held against the inner surface of the casing 202, and the radially outer surface of the valve body 204b in its entirety faces the groove 234 while the wall 242b having the recess r being held against the forward face of the ridge 235a. Therefore, a passage for the viscous fluid is provided between the radially outer surface of the valve body 204b and the inner surface of the casing 202, and through the recesses r, p of the wall 242a and the ridge 235a, respectively.

As the rotor 203 rotates from the position shown in FIG. 12B to the position shown in FIG. 12C, a passage for the viscous fluid 205 extends from the groove 234 which faces the valve body 204b, through the recess r in the wall 242a and through the recess p in the ridge 235a, to a space between the inner surface of the wall 241a and one side

surface of the ridge 235a. As a result, the fluid torque adjuster produces a relatively small torque.

When the rotor 203 rotates from the position shown in FIG. 12C to the position shown in FIG. 12D, the wall 241b of the valve body 204b comes to the terminal end E of the groove 234 and a front end of the radially outer surface of the valve body 204b contacts the inner surface of the casing 202 which has no groove. As a result, a fluid communication through the groove 234 is interrupted at the terminal end E of the groove 234. Since no recess is defined in the wall 241b of the valve body 204b, no fluid communication is established between the wall 241a of the valve body 204a and the wall 241b of the valve body 204b. Therefore, the fluid torque adjuster now produces a relatively large torque.

When the rotor 203 further rotates from the position shown in FIG. 12D, the outer surface of the wall 241b of the valve body 204b abuts against the other end 222a' of the land 222, as shown in FIG. 12E, whereupon the rotor 203 is stopped against rotation. During the rotation of the rotor 203 from the position shown in FIG. 12D to the position shown in FIG. 12E, as the radially outer surface of the valve body 204b is held against the inner surface of the casing 202, the fluid torque adjuster continues to produce a relatively large torque.

Consequently, according to the third embodiment, as with the first embodiment, when the door of the container is closed from the fully open position, the fluid torque adjuster generates a relatively large torque in a terminal range of the rotating stroke of the rotor 203, and generates a relatively low torque from a starting range of the rotating stroke of the rotor 203 prior to the terminal range of the rotating stroke thereof.

Now, an action of the fluid torque adjuster when the door of the container is opened from a fully closed position will be described below.

When the door of the container with the damper device 201 mounted thereon is fully closed, the parts of the damper device 201 are in the position shown in FIG. 12E. The wall 241b of the valve body 204b has an inner surface held against the lower surface, as shown in FIG. 12E, of the ridge 235b, and an outer surface held against the end 222a' of the land 222. The radially outer surface of the valve body 204b is held against the inner surface of the casing 202. The wall 242a of the valve body 204a has an inner surface held against the lower surface, as shown in FIG. 12E, of the ridge 235a. The radially outer surface of the valve body 204a faces the groove 234.

When the rotor 203 slightly rotates clockwise from the position shown in FIG. 12E to the position shown in FIG. 12F, the valve bodies 204a, 204b do not rotate until the inner surface of the wall 242b of the valve body 204b is brought into contact with the upper surface, as shown in FIG. 12F, of the ridge 235b, and the inner surface of the wall 241a of the valve body 204a is brought into contact with the upper surface, as shown in FIG. 12F, of the ridge 235a.

In the position shown in FIG. 12F, as with the position shown in FIG. 12E, the radially outer surface of the valve body 204b is held against the inner surface of the casing 202, and the radially outer surface of the valve body 204a faces the groove 234. Therefore, a clearance which is as deep as the groove 234 is provided between the radially outer surface of the valve body 204a and the inner surface of the casing 202.

As the rotor 203 rotates from the position shown in FIG. 12F to the position shown in FIG. 12G, a passage for the viscous fluid 205 extends from the groove 234 which faces

the valve body **204a**, through the recess *s* in the wall **242b** and through the recess *q* in the ridge **235b**, to a space between the inner surface of the wall **241b** and one side surface of the ridge **235b**. As a result, the fluid torque adjuster produces a relatively small torque.

When the rotor **203** rotates from the position shown in FIG. 12G to the position shown in FIG. 12H, the wall **241a** of the valve body **204a** reaches the starting end *S* of the groove **234**, and a front end of the radially outer surface of the valve body **204a** contacts the inner surface of the casing **202** which has no groove. As a result, a fluid communication through the groove **234** is interrupted at the starting end *S* of the groove **234**. Since no recess is defined in the wall **241a** of the valve body **204a**, no fluid communication is established between the wall **241a** of the valve body **204a** and the wall **241b** of the valve body **204b**. Therefore, the fluid torque adjuster now produces a relatively large torque.

When the rotor **203** further rotates from the position shown in FIG. 12H, the outer surface of the wall **241a** of the valve body **204a** abuts against the end **222a** of the land **222**, as shown in FIG. 12I, whereupon the rotor **203** is stopped against rotation. During the rotation of the rotor **203** from the position shown in FIG. 12H to the position shown in FIG. 12I, as the radially outer surface of the valve body **204a** is held against the inner surface of the casing **202**, the fluid torque adjuster continues to produce a relatively large torque.

Consequently, according to the third embodiment, as with the first and second embodiments, when the door of the container is closed from the fully open position, the fluid torque adjuster generates a relatively large torque in a terminal range of the rotating stroke of the rotor **203**, and generates a relatively low torque from a starting range of the rotating stroke of the rotor **203** prior to the terminal range of the rotating stroke thereof.

FIGS. 13 and 14 show how a torque is generated in the rotating strokes of the rotor **3** (**103**, **203**), in normal and reverse directions. FIG. 13 shows a generated torque when the rotor **3** (**103**, **203**) rotates in a counterclockwise stroke in FIGS. 4A–4E, 8A–8E, and 12A–12E, and FIG. 14 shows a generated torque when the rotor **3** (**103**, **203**) rotates in a clockwise stroke in FIGS. 4E–4I, 8E–8I, and 12E–12I. It can be seen from FIGS. 13 and 14 that a higher torque is generated in the terminal range of each of the counterclockwise and clockwise strokes of the rotor **3** (**103**, **203**).

Various modifications of the first through third embodiments will be described below.

FIGS. 15A and 15B show a modification of the first embodiment. As shown in FIGS. 15A and 15B, two spacers **304** are mounted respectively on diametrically opposite ridges **331** on the rotor **303**, and two diametrically opposite pairs of needle valves **309**, **309'** are disposed axially on the inner surface of the cylindrical casing **302**. Two first grooves **333** are defined in diametrically opposite relation in the outer surface of the rotor **303**. Therefore, the various parts are provided in two sets.

FIGS. 16A and 16B show a modification of the second embodiment. As shown in FIGS. 16A and 16B, two diametrically opposite axial lands **422** project radially inwardly from the inner surface of the cylindrical casing **402**, and two diametrically opposite pairs of needle valves **409**, **409'** are loosely fitted in respective grooves defined in lands **435** of the rotor **403**. Two grooves **434** are defined in diametrically opposite relation in the inner surface of the casing **402**. Therefore, the various parts are provided in two sets.

FIGS. 17A and 17B show a modification of the third embodiment. As shown in FIGS. 17A and 17B, two dia-

metrically opposite axial lands **522** project radially inwardly from the inner surface of the cylindrical casing **502**, and two diametrically opposite pairs of valve bodies **404a**, **404b** are circumferentially loosely fitted over respective ridges **435a**, **435b** of the rotor **403**. Two grooves **434** are defined in diametrically opposite relation in the inner surface of the casing **402**. Therefore, the various parts are provided in two sets.

FIGS. 15A, 16A, and 17A show the positions of the parts when the rotors **303**, **403**, **503** rotate counterclockwise, and FIGS. 15B, 16B, and 17B show the positions of the parts when the rotors **303**, **403**, **503** rotate clockwise.

Fluid torque adjusters according to these modifications operate in the same manner as with the fluid torque adjusters where the parts are provided in one set. The parts of the modified fluid torque adjusters may be dimensioned and positioned differently from those illustrated. While the parts are provided in two sets according to the modifications shown in FIGS. 15A, 15B, 16A, 16B, and 17A, 17B, the parts may be provided in three or more sets.

Other modifications of the first through third embodiments will be described below.

FIGS. 18A and 18B show another modification of the first embodiment. As shown in FIGS. 18A and 18B, a pair of diametrically opposite axial lands **608**, **608'** is disposed on the inner surface of the cylindrical casing **602**, and radially movable needle valves **609**, **609'** are loosely fitted in respective grooves **682**, **682'** defined axially in the lands **608**, **608'**. A pair of diametrically opposite ridges **631**, **631'** is disposed on the outer surface of the rotor **603**, and spacers **604**, **604'** are mounted on the respective ridges **631**, **631'**. Two grooves **633**, **633'** are defined in diametrically opposite relation in the outer surface of the rotor **603**. In the modification shown in FIGS. 18A and 18B, the various parts are provided in two sets. However, the grooves **682**, **682'** and the needle valves **609**, **609'** loosely fitted therein are provided one in each set.

FIGS. 19A and 19B show another modification of the second embodiment. As shown in FIGS. 19A and 19B, a pair of diametrically opposite first axial lands **722**, **722'** is disposed on the inner surface of the cylindrical casing **702**, and a pair of diametrically opposite second axial lands **735**, **735'** is disposed on the outer surface of the rotor **703**. Radially movable needle valves **709**, **709'** are loosely fitted in respective grooves **736**, **736'** defined axially in the second lands **735**, **735'**. Two grooves **734**, **734'** are defined in diametrically opposite relation in the inner surface of the casing **702**. In the modification shown in FIGS. 19A and 19B, the various parts are provided in two sets. However, the grooves **736**, **736'** and the needle valves **709**, **709'** loosely fitted therein are provided one in each set.

FIGS. 20A and 20B show another modification of the third embodiment. As shown in FIGS. 20A and 20B, a pair of diametrically opposite first axial lands **822**, **822'** is disposed on the inner surface of the cylindrical casing **802**, and a pair of diametrically opposite axial ridges **835a**, **835b** is disposed on the outer surface of the rotor **803**. Valve bodies **804**, **804'** are loosely mounted on the respective ridges **835a**, **835b**, and two grooves **834**, **834'** are defined in diametrically opposite relation in the inner surface of the casing **802**. In the modification shown in FIGS. 20A and 20B, the various parts are provided in two sets. However, the ridges **835a**, **835b** and the valve bodies **804a**, **804b** mounted thereon are provided one in each set.

FIGS. 18A, 19A, and 20A show the positions of the parts when the rotors **603**, **703**, **803** rotate counterclockwise, and FIGS. 18B, 19B, and 20B show the positions of the parts when the rotors **603**, **703**, **803** rotate clockwise.

## 15

Fluid torque adjusters according to these modifications operate in the same manner as with the fluid torque adjusters where the parts are provided in one set. The parts of the modified fluid torque adjusters may be dimensioned and positioned differently from those illustrated. While the parts are provided in two sets according to the modifications shown in FIGS. 18A, 18B, 19A, 19B, and 20A, 20B, the parts may be provided in three or more sets.

The damper device according to the present invention has been described as being applied to the door of a container for damping the door in terminal ranges of opening and closing movements of the door. However, the damper device may be used in other applications. For example, the damper device may be used in combination with reciprocally movable devices for applying damping forces to back-and-forth movements thereof in terminal ranges.

One of the other applications is as an electrically powered saw. Specifically, when the electrically powered saw is pushed to cut a piece of wood, the damper device applies damping forces to the saw in a terminal range of its stroke before the saw hits a rear stop, and when the electrically powered saw is pulled, the damper device also applies damping forces to the saw in a terminal range of its stroke before the saw hits a front stop.

In each of the above embodiments and modifications, the casing is fixed in position and the rotor is rotatable. However, the rotor may be fixed in position and the casing may be rotatable.

Although certain preferred embodiments of the present invention have been shown and described in detail, it should be understood that various changes and modifications may be made therein without departing from the scope of the appended claims.

What is claimed is:

1. A damper device comprising:

a cylindrical casing;

a rotor partly housed in said casing;

a viscous fluid filled in the said casing around said rotor; and

torque generating means for generating a torque during a rotating stroke of said rotor;

wherein said torque generating means includes fluid torque adjusting means for producing a relatively large torque in at least a terminal range of each rotating strokes in normal and reverse directions of said rotor and relatively small torque in other range of each of the rotating strokes and

said fluid torque adjusting means includes a circumferential groove defined circumferentially on one of an outer surface of said rotor and an inner surface of said casing, a land or ridge formed on the other of the outer surface of said rotor and the inner surface of said casing and valves disposed on said land or ridge and closing a space formed between an outer surface of said valve and the outer surface of said rotor or the inner surface of said casing on which said circumferential groove is circumferentially defined during each of rotating strokes of said rotor.

2. A damper device according to claim 1, wherein said torque generating means has a first ridge extending axially on an outer surface of said rotor and having a radially outer surface held in sliding contact with an inner surface of said casing, and wherein said fluid torque adjusting means comprises a first land extending axially on said inner surface of said casing, a pair of first axial grooves defined axially in a

## 16

radially inner end of said first land and spaced circumferentially from each other, a pair of first needle valves loosely fitted in said first axial grooves, respectively, for movement in the width direction of said first axial grooves, and a first circumferential groove defined circumferentially on said outer surface of said rotor, said first circumferential groove being positioned out of facing relation to at least one of said first needle valves in said terminal range of each of said rotating strokes, whereby when said at least one of the first needle valves is held against said outer surface of said rotor in said terminal range, said one of the first needle valves and said first ridge jointly divide an interior space of said casing into two chambers for effectively preventing the viscous fluid from moving between said chambers to produce the relatively large torque.

3. A damper device according to claim 2, wherein said first axial grooves each having a depth which varies from one end to an opposite end in the width direction of the first axial groove such that a shallowest portion is positioned at said one end of one of said first axial grooves and at said opposite end of the other of said first axial grooves.

4. A damper device according to claim 2, wherein said torque generating means and said fluid torque adjusting means are arranged in two sets.

5. A damper device according to claim 2, wherein said first ridge and said first circumferential groove on the outer surface of said rotor and said first land on the inner surface of said casing are provided in pairs, said pair of first ridges being arranged in a diametrically opposite relation to each other, said pair of first circumferential grooves being arranged in a diametrically opposite relation to each other and each between said first ridges, said pair of first lands being arranged in a diametrically opposite relation to each other, said pair of first axial grooves respectively receiving said pair of first needle valves therein being provided one on each of said pair of first lands.

6. A damper device according to claim 1, wherein said torque generating means has a second land extending axially on an inner surface of said casing and having a radially inner surface held in sliding contact with an outer surface of said rotor, and wherein said fluid torque adjusting means comprises a third land extending axially on said outer surface of said rotor, a pair of second axial grooves defined axially on a radially outer end of said third land on the rotor and spaced circumferentially from each other, a pair of second needle valves loosely fitted in said second axial grooves, respectively, for movement in the width direction of said second axial grooves, and a second circumferential groove defined circumferentially in said inner surface of said casing, said second circumferential groove being positioned out of facing relation to at least one of said second needle valves in said terminal range of each of said rotating strokes, whereby when said at least one of the second needle valves is held against said inner surface of said casing in said terminal range, said one of the second needle valves and said second land of the casing jointly divide an interior space of said casing into two chambers for effectively preventing the viscous fluid from moving between said chambers to produce the relatively large torque.

7. A damper device according to claim 6, wherein said second axial grooves each having a depth which varies from one end to an opposite end in the width direction of the second axial groove such that a shallowest portion is positioned at one end of one of said second axial grooves and at the opposite end of the other of said second axial grooves.

8. A damper device according to claim 6, wherein said torque generating means and said fluid torque adjusting means are arranged in two sets.

17

9. A damper device according to claim 6, wherein said second land and said second circumferential groove on the inner surface of said rotor and said third land on the outer surface of said casing are provided in pairs, said pair of second land being arranged in a diametrically opposite relation to each other, said pair of second circumferential grooves being arranged in a diametrically opposite relation to each other and each between said second land, said pair of third lands being arranged in a diametrically opposite relation to each other such that each of said third lands is positioned between said second lands, said pair of second axial grooves respectively receiving said pair of second needle valves therein being provided one on each of said pair of third lands.

10. A damper device according to claim 1, wherein said torque generating means has a fourth land extending axially on an inner surface of said casing and having a radially inner surface held in sliding contact with a outer surface of said rotor, and wherein said fluid torque adjusting means comprises a pair of second ridges extending axially on said outer surface of said rotor, a pair of valve bodies loosely mounted on said second ridges, respectively, and a third circumferential groove defined circumferentially in said inner surface of said casing, said third circumferential groove being positioned out of facing relation to at least one of said valve bodies in said terminal range of each of said rotating strokes, whereby when said at least one of the valve bodies is held

18

against said inner surface of said casing in said terminal range, said one of the valve bodies and said second ridges jointly divide an interior space of said casing into two chambers for effectively preventing the viscous fluid from moving between said chambers to produce the relatively large torque.

11. A damper device according to claim 10, wherein one of said valve bodies having an orifice which opens when said rotor rotates in one direction and the other of said valve bodies having an orifice which opens when said rotor rotates in a direction opposite to said one direction.

12. A damper device according to claim 10, wherein said torque generating means and said fluid torque adjusting means are arranged in two sets.

13. A damper device according to claim 10, wherein said fourth land and said third circumferential groove on the inner surface of said casing are provided in pairs, said pair of fourth lands being arranged in a diametrically opposite relation to each other, said pair of third circumferential grooves being arranged in a diametrically opposite relation to each other and each between said fourth lands, and said pair of second ridges being arranged in a diametrically opposite relation to each other such that each of said second ridges is positioned between said fourth lands.

\* \* \* \* \*