



US006198452B1

(12) **United States Patent**
Beheler et al.

(10) **Patent No.:** **US 6,198,452 B1**
(45) **Date of Patent:** **Mar. 6, 2001**

(54) **ANTENNA CONFIGURATION**
(75) Inventors: **Carl M. Beheler**, Richardson; **William H. Grona**, Dallas, both of TX (US)
(73) Assignee: **Rockwell Collins, Inc.**, Cedar Rapids, IA (US)
(*) Notice: Subject to any disclaimer, the term of this patent is extended or adjusted under 35 U.S.C. 154(b) by 0 days.

4,598,297 * 7/1986 Hawkins 343/882
4,994,816 * 2/1991 Kondo 343/762
5,419,521 * 5/1995 Matthews 248/278
5,945,961 * 8/1999 Price et al. 343/757

* cited by examiner

Primary Examiner—Tho Phan

(74) *Attorney, Agent, or Firm*—Nathan O. Jensen; Kyle Epele; J. P. O'Shaughnessy

(21) Appl. No.: **09/307,313**
(22) Filed: **May 7, 1999**
(51) **Int. Cl.**⁷ **H01Q 3/00**
(52) **U.S. Cl.** **343/757; 343/765; 343/839; 343/882**
(58) **Field of Search** 343/754, 755, 343/757, 758, 761, 781 P, 836, 837, 839, 840, 765, 880, 882; 342/372, 380

(57) **ABSTRACT**

A positioner (or gimbal assembly) for a compact antenna assembly is disclosed. The positioner provides accurate pointing of the antenna assembly (typically a narrow beam radio frequency (RF) radiating assembly) mounted on a rapidly moving platform. The positioner is comprised of a first, second, and third axis assemblies which support the antenna assembly and allow rotation of the antenna assembly about first, second, and third axis. The axis assemblies are arranged so the first, second and third axis are non-orthogonal and intersect at the approximate geometric center of the antenna assembly allowing continuous and independent rotation of the antenna assembly about each axis within a confined volume.

(56) **References Cited**

U.S. PATENT DOCUMENTS

4,251,819 * 2/1981 Vickland 343/882
4,516,128 * 5/1985 Watanabe et al. 343/761

20 Claims, 3 Drawing Sheets

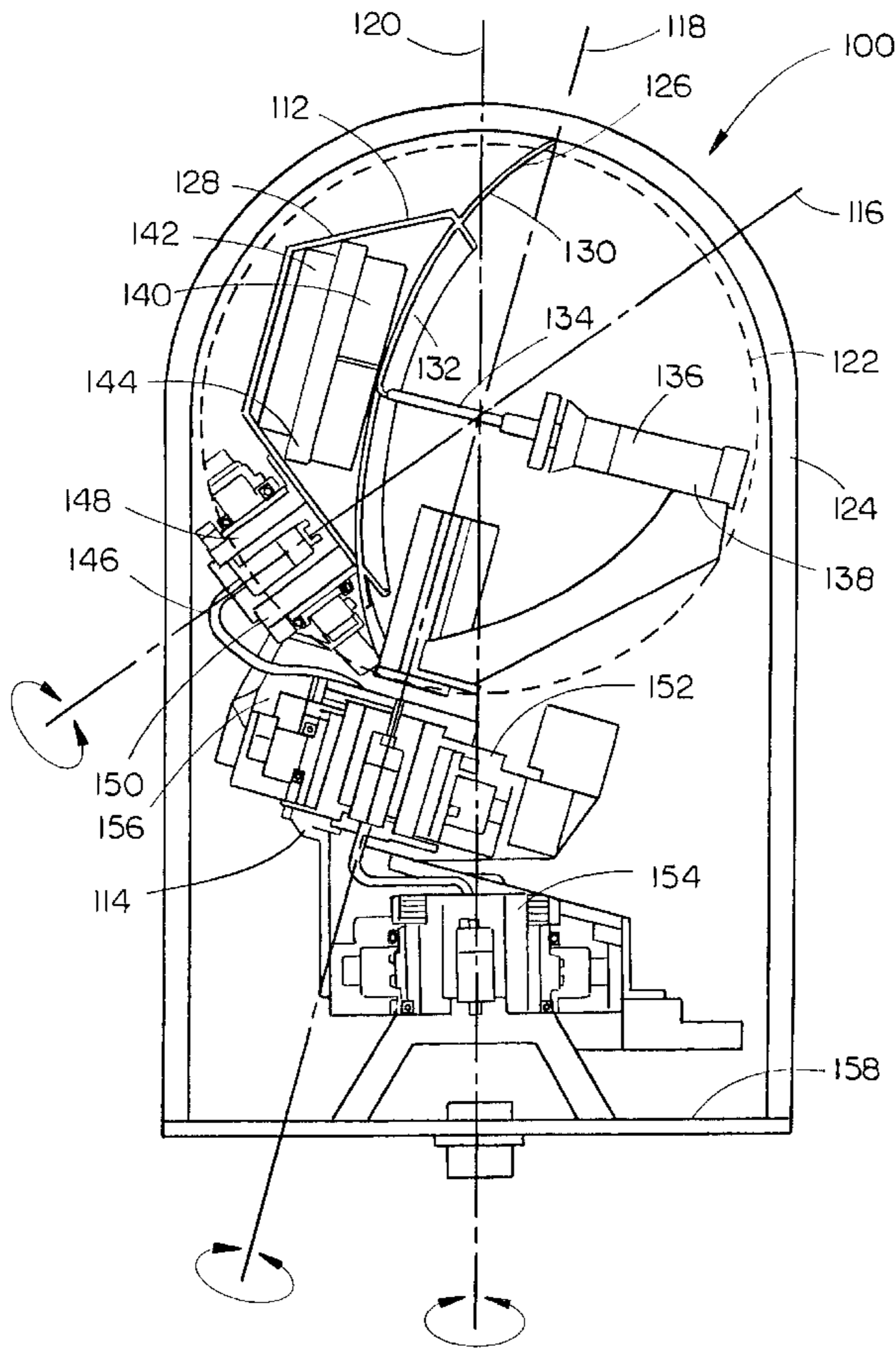

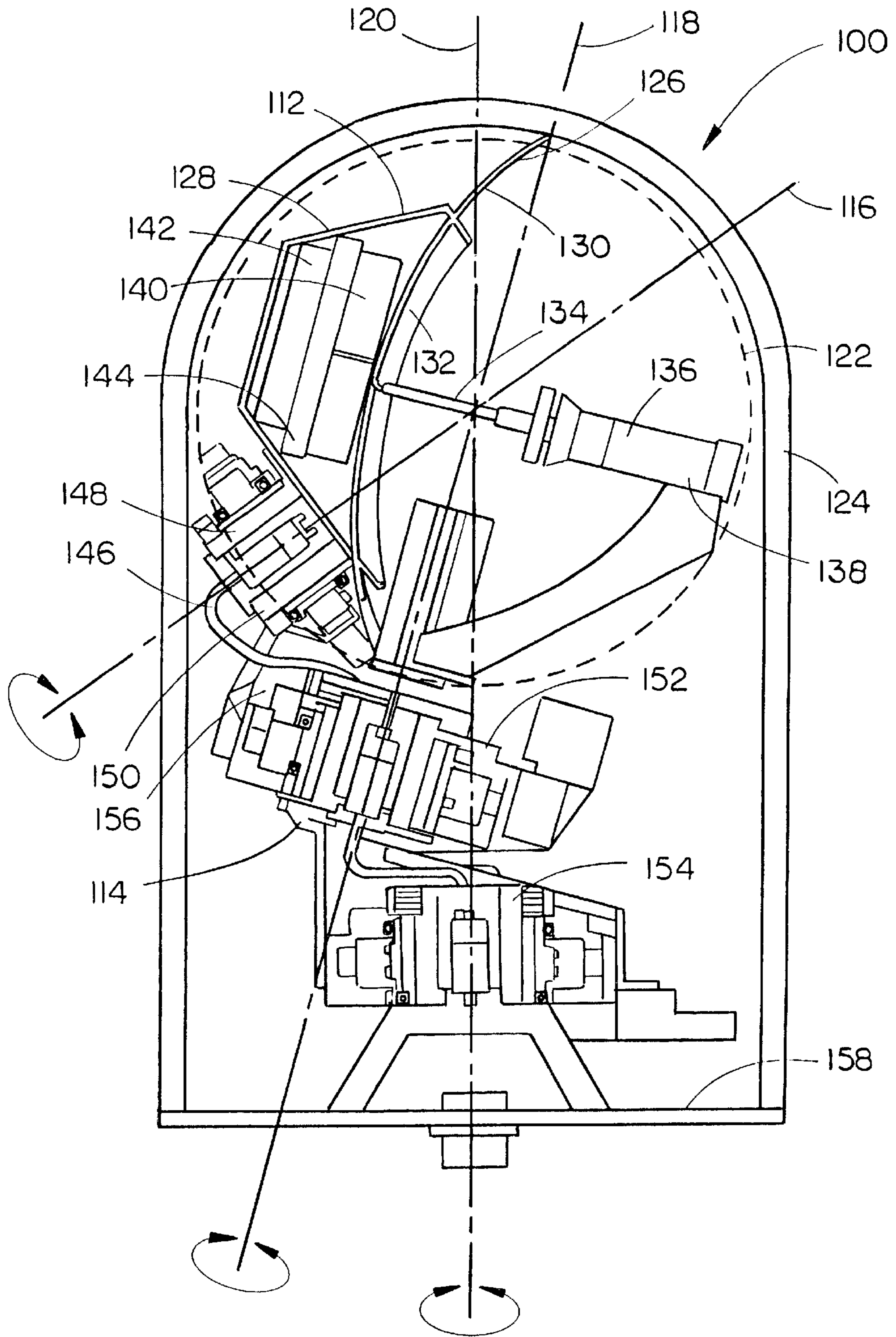

FIG. 1

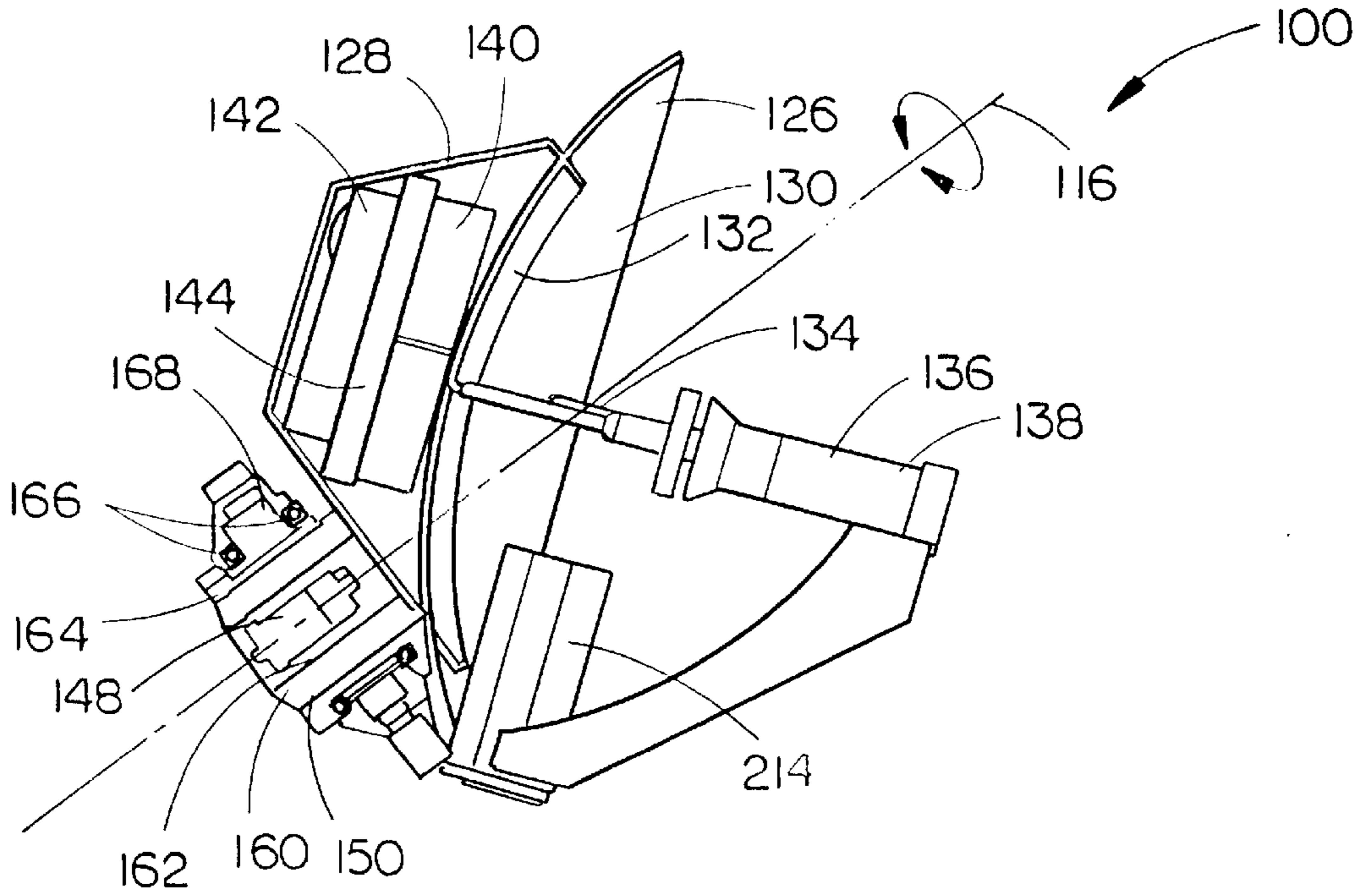

FIG. 2

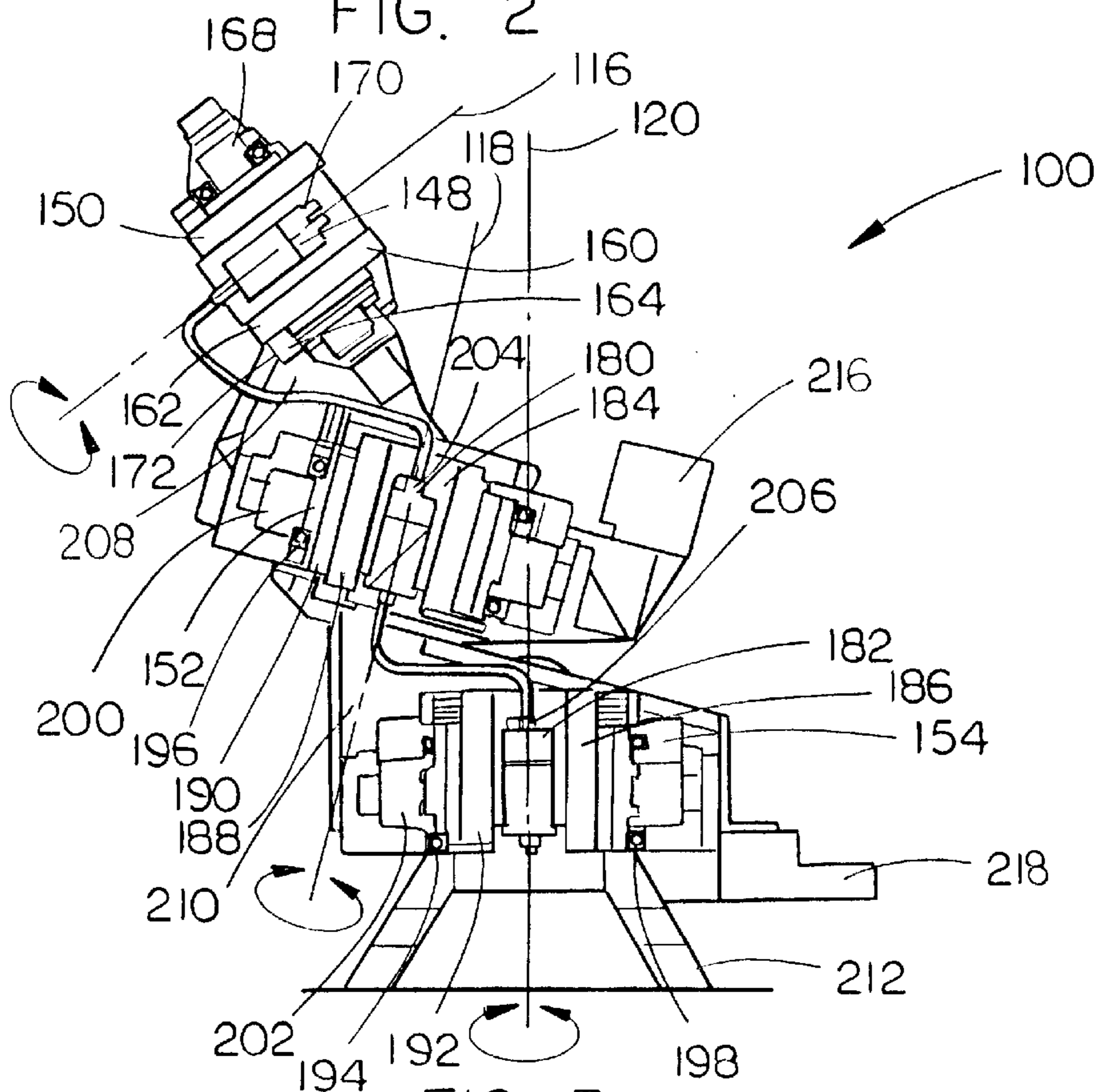

FIG. 3

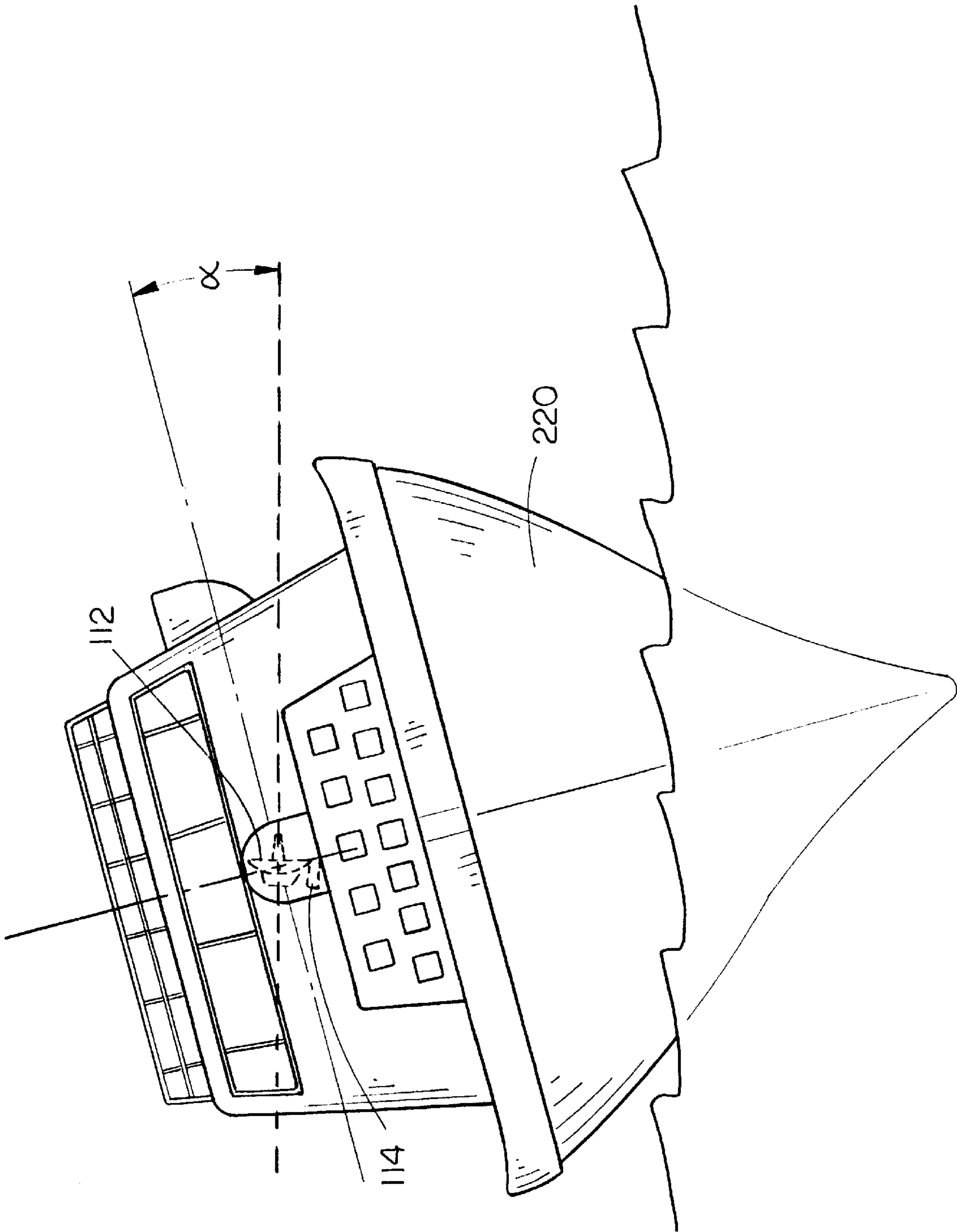

FIG. 4

ANTENNA CONFIGURATION

BACKGROUND OF THE INVENTION

The present invention generally relates to radio frequency (RF) antennas, and particularly to a positioner or gimbal assembly for an antenna mounted to a platform subject to submarine motion such as a ship, submarine, or the like.

Millimeter-wave RF antennas intended for use aboard ships or submarines, or on similarly moving platforms face extraordinarily severe operating requirements and constraints including limited allowable swept volume, complete hemispherical coverage under significant platform dynamics, very strong/rigid gimbal structure and high radio frequency (RF) performance (e.g., effective isotropic radiated power (EIRP) and gain-to-noise-temperature-ratio (G/T)). Because of the severe attenuation of practical, millimeter-wave, high-power transmission line technologies, the need for higher EIRP performance from relatively small diameter apertures has driven placement of the antenna's millimeter-wave RF power amplifier unit as close to the feed input port as possible. The size and weight of such devices, together with the desire for multi-frequency band operation, have led to a strong desire for a positioner that has the ability to accommodate relatively heavy loads on its axis. Thus, the necessity of intersecting gimbal axis driven by the need for minimum swept volume forces normal, 3-axis gimbal configurations using orthogonal axis into geometrical arrangements which significantly decrease the effective antenna aperture in order to withstand the imposed loading requirements.

Accordingly, a goal of the present invention is to provide a positioner for a compact millimeter-wave RF antenna mounted on a rapidly moving platform which provides accurate pointing of a narrow beam radio frequency (RF) radiating assembly to provide complete hemispherical coverage within a confined volume (i.e., a minimum swept volume).

SUMMARY OF THE INVENTION

The present invention is directed to a novel positioner (or gimbal assembly) for compact RF antennas suitable for mounting to platforms subject to submarine motion. The positioner provides accurate pointing of a narrow beam radio frequency (RF) radiating assembly [hereinafter antenna assembly] to provide complete hemispherical coverage under significant platform dynamics. The positioner is comprised of a first axis assembly supporting the antenna assembly, which is configured to rotate the antenna assembly about a first axis. A second axis assembly supports the first axis and antenna assemblies and is configured to rotate the antenna assembly about a second axis. A third axis assembly supports the antenna assembly and first and second axis assemblies, and is configured to rotate the antenna assembly about a third axis. The axis assemblies are arranged so the first, second and third axis are non-orthogonal and intersect at the approximate geometric center of the antenna assembly allowing continuous and independent rotation of the antenna assembly about each axis within a confined volume. This allows the diameter of the radiating aperture (i.e., the antenna's reflector) to be maximized for a given minimum swept area.

It is to be understood that both the foregoing general description and the following detailed description are exemplary and explanatory only and are not restrictive of the invention claimed. The accompanying drawings, which are incorporated in and constitute a part of the specification,

illustrate an embodiment of the invention and together with the general description, serve to explain the principles of the invention.

BRIEF DESCRIPTION OF THE DRAWINGS

The numerous objects and advantages of the present invention may be better understood by those skilled in the art by reference to the accompanying figures in which:

FIG. 1 is a side elevational cross-sectional view of a radio frequency (RF) antenna having a three-axis positioner;

FIG. 2 is a side elevational cross-sectional view of the antenna assembly and first axis assembly of the RF antenna shown in FIG. 1;

FIG. 3 is a side elevational cross-sectional view of the three-axis positioner shown in FIG. 1 illustrating the second and third axis assemblies; and

FIG. 4 is a bow elevational view of a ship having an RF antenna in accordance with the present invention.

DESCRIPTION OF THE PREFERRED EMBODIMENT

Reference will now be made in detail to the presently preferred embodiment of the invention, an example of which is illustrated in the accompanying drawings.

Referring now to FIG. 1, a radio frequency (RF) antenna having a positioner or gimbal assembly in accordance with an exemplary embodiment of the present invention is shown. The antenna **100** is comprised of an antenna assembly **112** rotatably mounted to a three-axis positioner **114**. The positioner **114** provides rotation of the antenna assembly **112** independently about any of three non-orthogonal axis **116**, **118** & **120** while remaining within the confined hemispherical envelope **122** of a radome **124**. This allows the diameter of the radiating aperture (i.e., the antenna's reflector/RF feed assembly **126**) to be maximized for a given minimum swept area.

Turning now to FIGS. 1 and 2, the antenna assembly **112** is shown. The antenna assembly **112** includes a reflector/RF feed assembly **126** and an RF amplifier enclosure/reflector support structure **128**. In the exemplary embodiment shown, wherein the antenna **100** may be utilized aboard a ship or submarine in a satellite communication (SATCOM) system, the reflector/RF feed assembly **126** may include a main reflector **130**, an EHF (Elevated High Frequency Antenna) subreflector **132**, an EHF feed/polarizer/diplexer package **134**, a DSCS (Defense Satellite Communications System) feed/polarizer/diplexer assembly **136**, waveguide filters **138**, and waveguide extensions (not shown) to connect the EHF and DSCS low noise amplifiers (LNA) **140** and solid state power amplifiers (SSPA) **142**.

The RF amplifier enclosure/reflector support structure **128** comprises an air-cooled box structure extending from the rear of the main reflector **130** to mount the reflector/RF feed assembly **126** onto the positioner **114**. Preferably, the EHF and DSCS amplifiers (LNA's and SSPA's) **140** & **142** mount to a finned, air-cooled mounting plate **144** within the RF amplifier enclosure/reflector support structure **128**. Fans or blowers (not shown) are mounted to opposite sidewalls of the RF amplifier enclosure/reflector support structure **128** to force air through the fins of the mounting plate **144** to cool the components contained therein. Coaxial couplers and cables **146** interconnect components within the RF amplifier enclosure/reflector support structure **128** to a common, dual channel RF rotary joint **148**.

The main reflector **130** may be equipped with pads (not shown) on its rear surface to which DC-DC converters (now

shown) are mounted. The DC-DC converters receive high voltage, low current power from inboard equipment, and convert it to low voltage, high current power for the SSPA's **142**.

The signal input/output (I/O) control module (not shown) may be mounted within the RF amplifier enclosure/reflector support structure **128**. The I/O control module continuously samples all control and status signals and transmits the signals to a remotely located (e.g., below deck) antenna control unit (ACU) (not shown). The digital output data stream provided by the I/O control module provides all data required by the ACU to accurately point the antenna assembly **112** and control its operation.

Referring now to FIGS. **1**, **2** and **3**, the three-axis positioner **114** is shown. The positioner **114** is comprised of first (or inclined elevation), second (or canted azimuth), and third (or lower azimuth) axis assemblies **150**, **152** & **154** which support and rotate the antenna assembly **112** to provide a full range of motion thereto about each of the three axis **116**, **118** & **120**. The first axis assembly **150** is attached to the RF amplifier enclosure/reflector support structure **128** to support and rotate the antenna assembly **112** about the first axis **116**. The second axis assembly **152** supports the first axis assembly **150** and the antenna assembly **112**. The second axis assembly **152** rotates the antenna assembly **112** (and the first axis assembly **150**) about the second axis **118**. Similarly, the third axis assembly **154** supports the antenna assembly **112** and first and second axis assemblies **150** & **152**, and rotates the antenna assembly **112** (and the first and second axis assemblies **150** & **152**) about the third axis **120**.

To minimize the swept volume of the positioner **114**, the first, second, and third axis assemblies **150**, **152** & **154** are arranged so the first, second and third axis **116**, **118** & **120** are non-orthogonal and intersect at a single point. Preferably, this point is on axis and positioned at the approximate geometric center of the antenna assembly **112**. This allows continuous and independent rotation of the antenna assembly **112** about each axis **116**, **118** & **120** within a confined volume (e.g., within the radome **124**).

The arrangement of the first, second, and third axis assemblies **150**, **152** & **154** allows a very large diameter radiating aperture for a given radome diameter. For example, within a standard 21.75 inch outside diameter radome **124**, the positioner **114** supports a 19.5 inch diameter reflector. Conventional orthogonal positioners, on the other hand, typically allow reflectors having diameters of no more than approximately 16 inches for such a radome **124**. Additionally, the positioner **114**, because of its configuration, provides a naturally stiff and rigid structure, making higher locked-motor resonance frequencies easier to realize. Further, all three axis assemblies **150**, **152** & **154** comprise continually rotating structures with no mechanical stops or limits. Thus, no brakes or stow mechanisms are required to lock the first, second or third axis assemblies **150**, **152** & **154** in place when unpowered.

As can be seen from FIG. **1**, the first and second axis assemblies **150** & **152** form a differential mount **156** for the antenna assembly **112**. The third axis assembly **154** supports the differential mount **156**. Preferably, the third axis assembly **154** resembles a conventional azimuth axis assembly allowing the third axis **120** to be generally vertical with respect to the platform **158**.

The first and second axis assemblies **150** & **152** forming the differential mount **156** are preferably inclined approximately 15 degrees with respect to the third axis **120**. Because the platform **158** (e.g., the deck of a ship or submarine) on

which the antenna **100** is mounted is subject to submarine motion, the second and third axis assemblies **152** & **154** serve to shift the narrow beam radiated by the antenna assembly **112** (i.e., the keyhole) away from the operating zone of the antenna **100** so that tracking is continuous even under worst case platform movement (e.g., in worst case sea conditions).

As shown in FIG. **2**, the first axis assembly **150** includes the RF rotary joint **148**, a slip ring assembly **160** (comprised of inner and outer slip rings **162** & **164**), angular contact bearings **166** (two are shown), a direct current (DC) torque motor **168**, and a two-speed resolver (not shown). The slip ring assembly **160** allows unlimited motion of the antenna assembly **112** about the first (inclined elevation) axis **116**. Quick disconnect connectors **170** are provided to the RF rotary joint **148** for ease of maintenance.

As shown in FIG. **3**, the inner slip ring **162** of the slip ring assembly **160** is preferably attached to the RF amplifier enclosure/reflector support structure **128** to support the antenna assembly **112** while the outer slip ring **164** is housed within the outer driven portion **172** of the second axis assembly **152**. The angular contact bearings **166**, disposed between the inner and outer slip rings **162** & **164**, reduce friction within the slip ring assembly **160** due to rotation of the antenna assembly **112**. Preferably, preload of the angular contact bearings **166** is easily adjusted by maintenance personnel.

The DC torque motor **168** rotates the inner and outer slip rings **162** & **164** with respect to each other thereby producing rotation of the antenna assembly **112** about the first axis **116**. The resolver provides position loop data for the antenna assembly **112** with respect to the first axis **116** to the ACU (not shown). The ACU in turn controls operation of the DC torque motor **168** to rotate the antenna assembly **112** about the first axis **116** as necessary for continuous tracking by the antenna **100**.

As further shown in FIG. **3**, the second and third axis assemblies **152** & **154**, like the first axis assembly **150**, include RF rotary joints **180** & **182**, slip ring assemblies **184** & **186** (comprised of inner and outer slip rings **188** & **190** and **192** & **194**, respectively), angular contact bearings **196** & **198**, DC torque motors **200** & **202**, and two-speed resolvers (not shown). Quick disconnect connectors **204** & **206** are provided to the RF rotary joints **180** & **182** for ease of maintenance.

The outer slip ring **190** of the second axis assembly **152** is attached to the assembly's upper transition member **208** which in turn supports the first axis assembly **150** (and the antenna assembly **112**). The inner slip ring **188** connects directly to the outer housing of the third axis assembly **154** and rotates within the outer slip ring **190** to provide unlimited motion of the antenna assembly **112** about the second (canted azimuth) axis **118**. Similarly, the outer slip ring **194** of the third axis assembly **154** is attached to the lower transition member **210** of the third axis assembly **154**. The lower transition member **210** in turn supports the second axis assembly **152** (as well as the first axis assembly **150** and the antenna assembly **112**). The inner slip ring **192** connects directly to the lower azimuth riser **212** at the base of the antenna **100** and rotates within the outer slip ring **194** to provide unlimited motion of the antenna assembly **112** about the third (lower azimuth) axis **120**.

The DC torque motors **200** & **202** rotate the antenna assembly **112** (and first and second axis assemblies **150** & **152**) about the second and third axis **118** & **120**, respectively. The resolvers provide position loop data for the antenna

assembly **112** with respect to the second and third axis **118** & **120** to the ACU (not shown) so the ACU may control operation of the DC torque motors **200** & **202** to rotate the antenna assembly **112** about the second and third axis **118** & **120** as necessary for proper tracking by the antenna **100**.

Preferably, the first, second, and third axis assemblies **150,152** & **154** employ identical rotary joints **148,180** & **182**, slip ring assemblies **160,184** & **186**, and resolvers. This commonality of parts and design among the first, second and third axis assemblies **150,152** & **154** provides advantages such as reduced cost, simpler maintenance, and smaller inventory of spare parts. The DC torque motors **200** & **202** and angular contact bearings **196** & **198** of the second and third axis assemblies **152** & **154** may be slightly larger than their counterparts within the first axis assembly **150** due to slightly greater drive requirements.

The positioner **114** must be balanced precisely within the confined space of the radome **124**. This balancing is preferably accomplished by providing each axis assembly **150, 152** & **154** with a counterweight **214, 216** & **218** to balance its mass during rotation. Each counterweight **214, 216** & **218** is fabricated from a dense material such as depleted uranium or a tungsten alloy (such alloys have a density slightly less than that of depleted uranium). In the exemplary embodiment shown in FIGS. **2** and **3**, the counterweight **214** of the first axis assembly **150** comprises a ring sector extending from the lower rim of the main reflector **130**. The counterweight **216** of the second axis assembly **152** is attached to the assembly's outer housing. Preferably, the position of the counterweight **216** may be adjusted radially to obtain precise balancing of the second axis assembly **152**. The counterweight **218** of the third axis assembly **154** swings in a space beneath the base heat exchanger (not shown) rather than extending radially from the outer, movable portion of the third axis assembly **154**.

Referring now to FIG. **4**, mounting of the RF antenna aboard a ship is shown. The orientation of the axis **116,118** & **120** allows a large amount of lookdown (i.e., negative deck-frame elevation angle (α)) by the antenna assembly **112** with negligible blockage of the radiation aperture by the positioner **114**. Preferably, negative deck-frame angles (α) of up to approximately 15 degrees are possible. This allows full hemispheric RF coverage even under worst case platform inclination (i.e., extreme listing of ship **220** due rough seas or hard maneuver). In contrast, conventional axis arrangements suffer severe blockage at such angles when swept volume is minimized.

It is believed that the present invention and many of its attendant advantages will be understood by the foregoing description, and it will be apparent that various changes may be made in the form, construction and arrangement of the components thereof without departing from the scope and spirit of the invention or without sacrificing all of its material advantages. The form herein before described being merely an explanatory embodiment thereof, it is the intention of the following claims to encompass and include such changes.

What is claimed is:

1. A positioner for mounting an antenna assembly on a moving platform, comprising:

a first axis assembly supporting the antenna assembly, said first axis assembly configured to rotate the antenna assembly about a first axis;

a second axis assembly supporting the first axis assembly and antenna assembly, said second axis assembly configured to rotate the antenna assembly about a second axis; and

a third axis assembly supporting the antenna assembly and first and second axis assemblies, said third axis assembly configured to rotate the antenna assembly about a third axis;

wherein the first, second and third axes are non-orthogonal and intersect at the approximate geometric center of the antenna assembly allowing continuous and independent rotation of the antenna assembly about each axis within a confined volume.

2. The positioner of claim **1**, wherein each of said first, second and third axis assemblies comprises a rotary joint.

3. The positioner of claim **2**, wherein said rotary joint further comprises an angular contact bearing.

4. The positioner of claim **2**, wherein each of said first, second and third axis assemblies further comprise a torque motor.

5. The positioner of claim **2**, wherein each of said first, second and third axis assemblies further comprise a resolver.

6. The positioner of claim **2**, wherein each of said first, second and third axis assemblies further comprise a counterweight.

7. The positioner of claim **1**, wherein said first, second and third axis assemblies allow the antenna assembly to be pointed at an angle below a surface of the moving platform.

8. The positioner of claim **7**, wherein said angle is between 0 and approximately 15 degrees.

9. The positioner of claim **1**, wherein said first and second axis assemblies form a differential mount for the antenna assembly, and wherein the differential mount is inclined at an angle with respect to the third axis.

10. The positioner of claim **9**, wherein said angle is between 0 and approximately 15 degrees.

11. A radio frequency antenna configured to be mounted on a moving platform, comprising:

an antenna assembly; and

a positioner supporting said antenna assembly; said positioner including:

a first axis assembly supporting said antenna assembly, said first axis assembly configured to rotate said antenna assembly about a first axis;

a second axis assembly supporting said first axis assembly and said antenna assembly, said second axis assembly configured to rotate said antenna assembly about a second axis; and

a third axis assembly supporting said antenna assembly and said first and second axis assemblies, said third axis assembly configured to rotate said antenna assembly about a third axis,

wherein the first, second and third axis are non-orthogonal and intersect at the approximate geometric center of said antenna assembly allowing continuous and independent rotation of the antenna about each axis within a confined volume.

12. The radio frequency antenna of claim **11**, wherein each of said first, second and third axis assemblies comprises a rotary joint.

13. The radio frequency antenna of claim **12**, wherein said rotary joint further comprises an angular contact bearing.

14. The radio frequency antenna of claim **12**, wherein each of said first, second and third axis assemblies further comprise a torque motor and a resolver.

15. The radio frequency antenna of claim **12**, wherein each of said first, second and third axis assemblies further comprise a counterweight.

16. The radio frequency antenna of claim **11**, wherein said first, second and third axis assemblies allow the antenna

7

assembly to be pointed at an angle below a surface of the moving platform.

17. The radio frequency antenna of claim 16, wherein said angle is between 0 and approximately 15 degrees.

18. The radio frequency antenna of claim 11, wherein said first and second axis assemblies form a differential mount for the antenna assembly, and wherein the differential mount is inclined at an angle with respect to the third axis. 5

19. The radio frequency antenna of claim 18, wherein said angle is between 0 and approximately 15 degrees. 10

20. A positioner for mounting an antenna assembly on a moving platform, comprising:

means, supporting the antenna assembly, for rotating the antenna assembly about a first axis;

8

means, supporting the first rotating means and antenna assembly, for rotating the antenna assembly about a second axis; and

means, supporting the antenna assembly and first and second rotating means, for rotating the antenna assembly about a third axis,

wherein the first, second and third axis are non-orthogonal and intersect at the approximate geometric center of the antenna assembly allowing continuous and independent rotation of the antenna assembly about each axis within a confined volume.

* * * * *