



US006178201B1

(12) **United States Patent**
Hillery

(10) **Patent No.:** **US 6,178,201 B1**
(45) **Date of Patent:** **Jan. 23, 2001**

(54) **CONTROLLING AN ADAPTIVE EQUALIZER
IN A DEMODULATOR**

(75) Inventor: **William J. Hillery**, Santa Clara, CA
(US)

(73) Assignee: **Agilent Technologies Inc.**, Palo Alto,
CA (US)

(*) Notice: Under 35 U.S.C. 154(b), the term of this
patent shall be extended for 0 days.

(21) Appl. No.: **09/038,656**

(22) Filed: **Mar. 11, 1998**

(51) **Int. Cl.**⁷ **H03H 7/30**; H03H 7/40;
H03K 5/159

(52) **U.S. Cl.** **375/232**; 708/323

(58) **Field of Search** 375/232, 233,
375/230, 229; 348/607; 708/322, 323; 333/18,
28 R

(56) **References Cited**

U.S. PATENT DOCUMENTS

5,418,817 * 5/1995 Richter 375/232

5,506,871 * 4/1996 Hwang et al. 375/230
5,517,213 * 5/1996 Bhatt et al. 375/232
5,809,074 * 9/1998 Werner et al. 375/233
5,835,532 * 11/1998 Strolle et al. 375/233
5,841,484 * 11/1998 Hulyalkar et al. 348/607

* cited by examiner

Primary Examiner—Stephen Chin
Assistant Examiner—Betsy L. Deppe

(57) **ABSTRACT**

An adaptive equalizer for a demodulator includes a filter that generates a filter output signal in response to an information signal according to a transfer function for the filter. The adaptive equalizer includes means for adjusting the transfer function in response to an indication of error in the filter output signal, and means for switching among a set of differing determinations of the indication of error. Switching among the differing determinations may be based upon a variety of indications of the progress of adaptation in the equalizer.

6 Claims, 3 Drawing Sheets

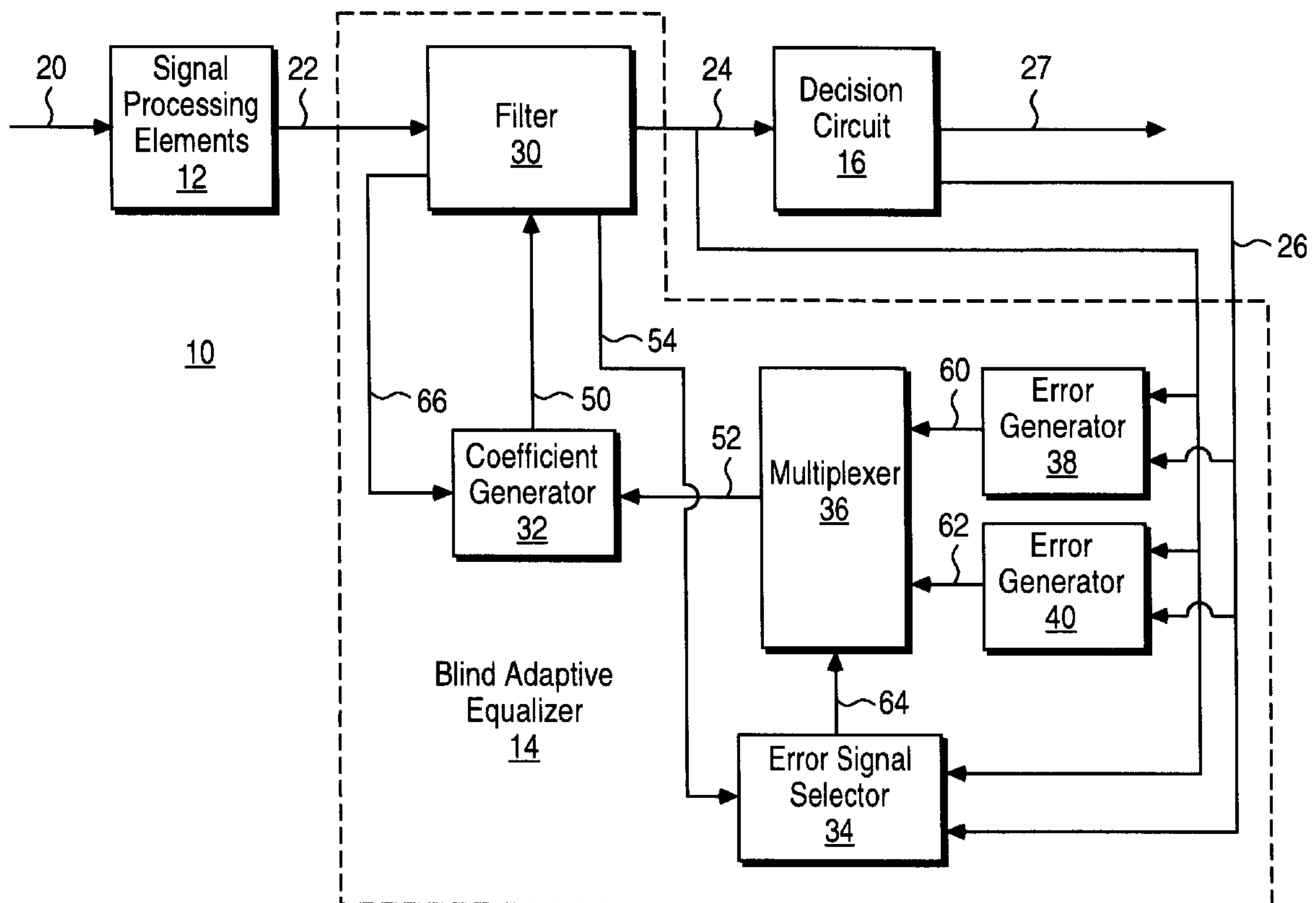

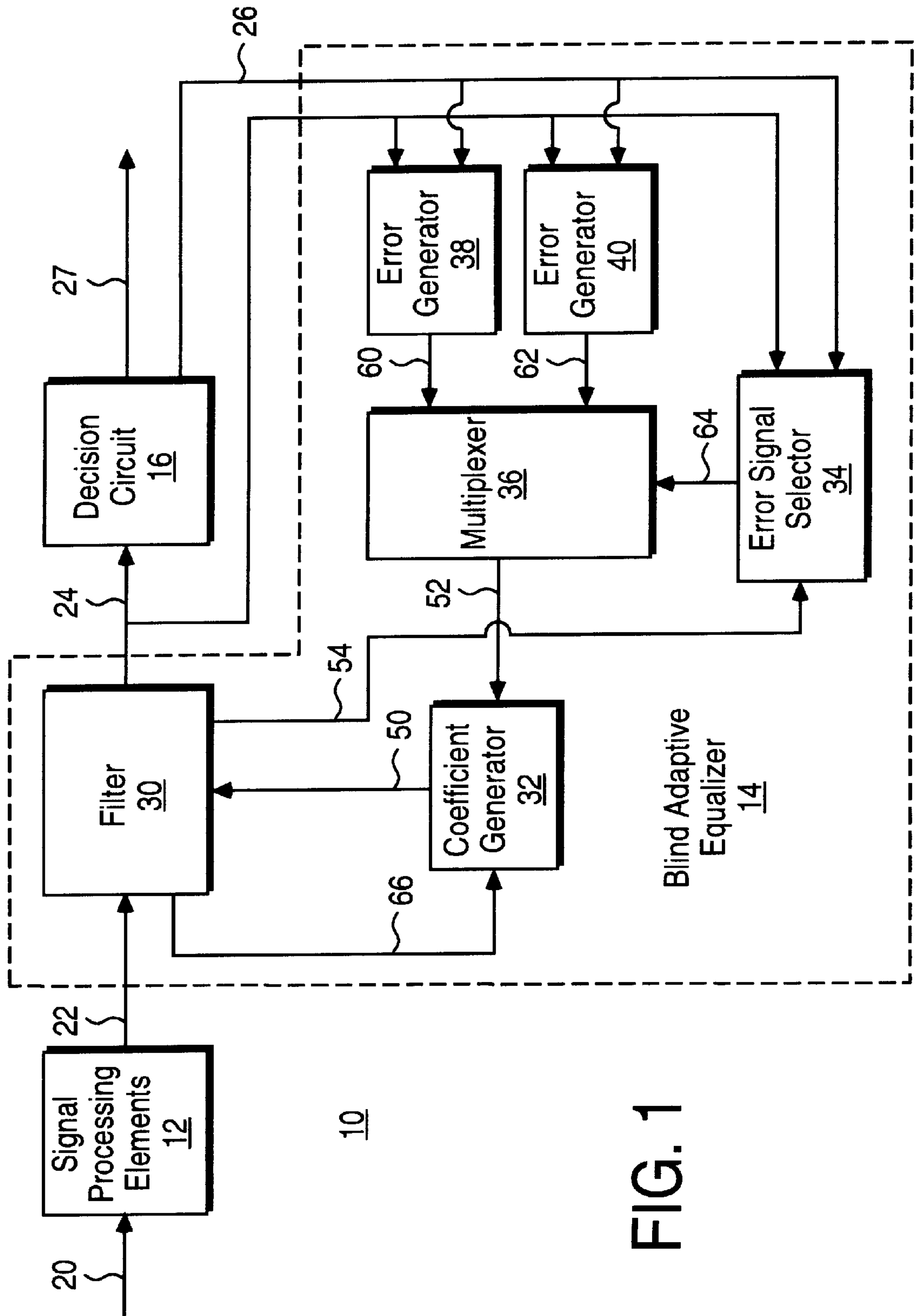

FIG. 1

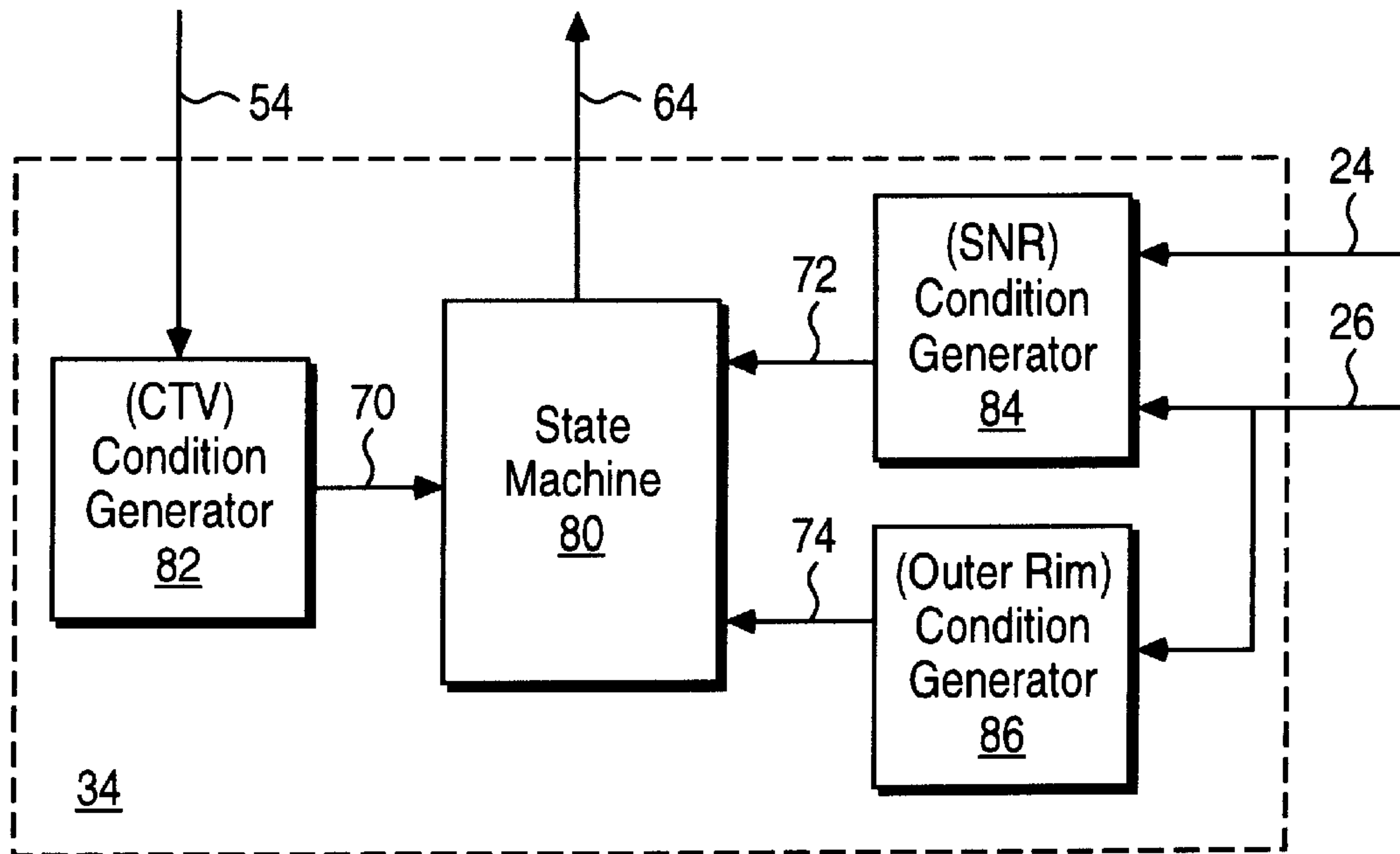

FIG. 2

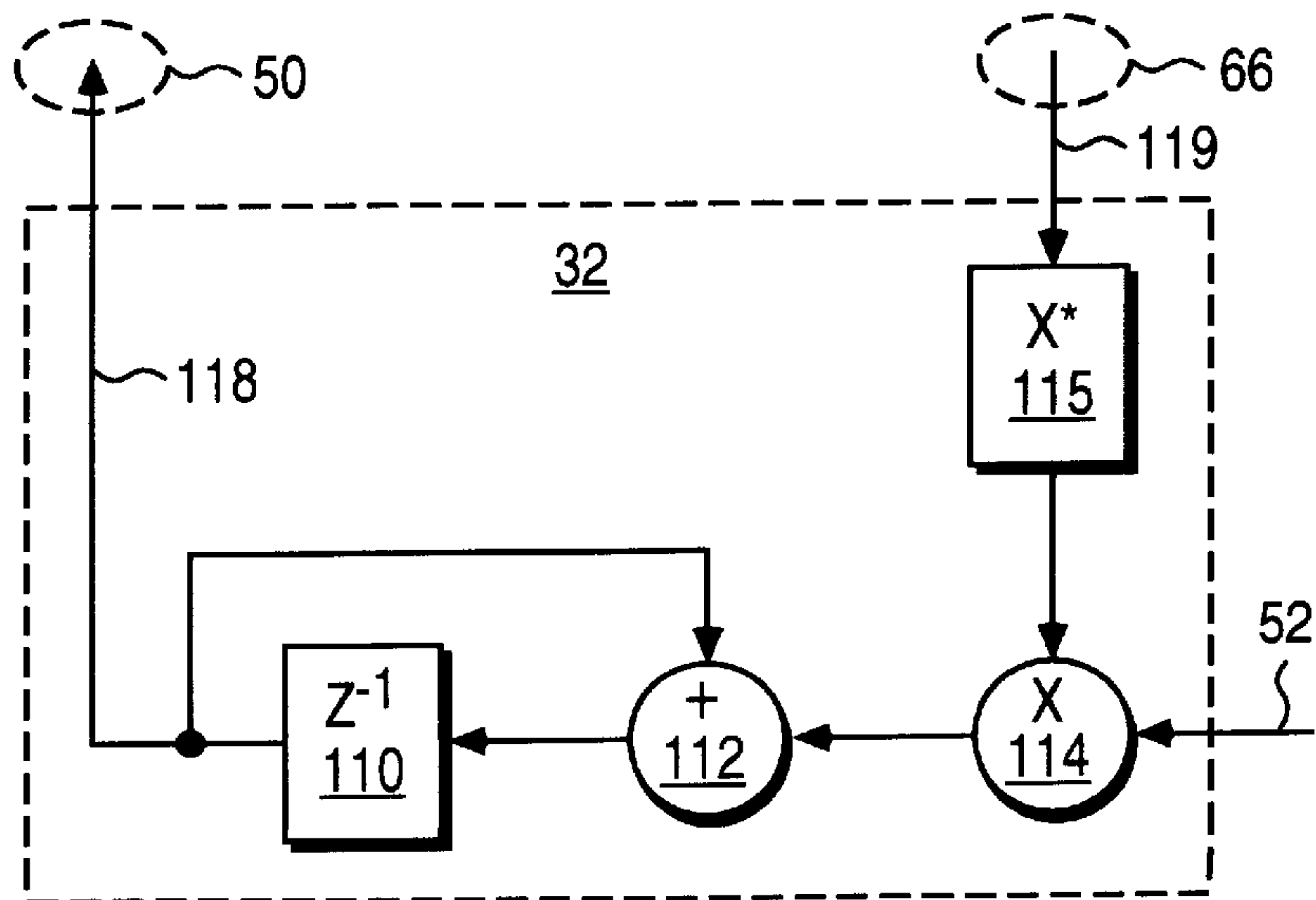
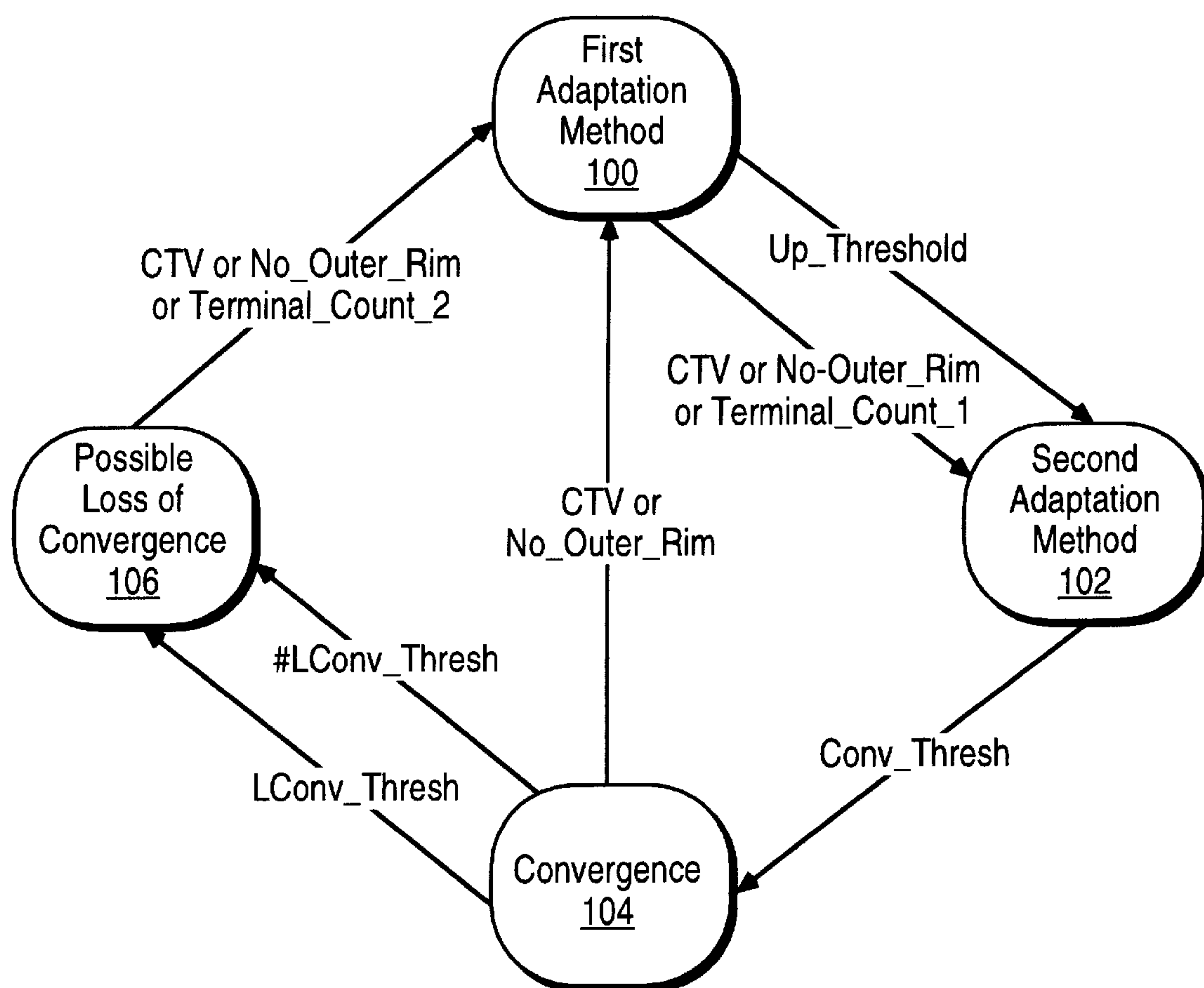

FIG. 4

FIG. 3



CONTROLLING AN ADAPTIVE EQUALIZER IN A DEMODULATOR

BACKGROUND OF THE INVENTION

1. Field of Invention

The present invention pertains to the field of demodulators. More particularly, this invention relates to controlling an adaptive equalizer in a demodulator.

2. Art Background

Communication systems commonly employ signal modulation to generate an information signal which is suitable for transmission via a physical communication path. For example, signal modulation is commonly employed in communication systems that transport information signals via transmission lines. Such communication systems include cable networks.

Such a communication system usually includes a transmitting station having a modulator that generates the information signal and a receiving station having a demodulator that extracts the information carried by the information signal. Typically, the transmitting and receiving stations are interconnected via one or more physical communication paths.

The communication paths in a typical communication system commonly include a variety of elements which introduce imperfections into the information signal. For example, transmission line connectors commonly cause signal reflections that distort the information signal. In addition, components such as signal amplifiers and filters may distort the information signal. Moreover, communication paths commonly have non-linear frequency and phase response which introduces further distortions into an information signal.

Prior demodulators may include an adaptive equalizer which is intended to compensate for the distortions which may be introduced into the information signal during transmission. A typical adaptive equalizer includes a filter and circuitry that continually adapts the filter according to a particular adaptation method. Prior adaptation methods are usually based upon a determination of an error measure for the adaptive equalizer. The adaptive equalizer is said to reach convergence when this error measure is small enough to yield a reliable output signal for the demodulator.

An adaptive equalizer may be classified as either blind or non-blind. A non-blind adaptive equalizer may be defined as an equalizer that adapts to a training sequence of symbols which is periodically carried in the information signal. A blind adaptive equalizer may be defined as an equalizer that adapts to a random symbol sequence in the information signal without the aid of a training sequence. It may in some systems be desirable to employ a blind adaptive equalizer. For example, a blind adaptive equalizer would eliminate the need for a training sequence which would ordinarily decrease the information throughput of a communication system.

Unfortunately, prior adaptation methods which may be useful for a blind adaptive equalizer commonly have difficulty in reaching a desirable point of convergence. For example, a common prior adaptation method in a blind adaptive equalizer employs a constant modulus algorithm (CMA) to recursively determine an error measure. Typically, the CMA adaptation method initially moves an equalizer toward convergence. The CMA adaptation method, however, usually has difficulty reaching a point of convergence that will yield a reliable output signal for the demodulator.

SUMMARY OF THE INVENTION

An adaptive equalizer for a demodulator is disclosed which switches among differing adaptation methods depending upon the progress of adaptation. The adaptive equalizer includes a filter that generates a filter output signal in response to an information signal according to a transfer function for the filter. The adaptive equalizer includes means for adjusting the transfer function in response to an indication of error in the filter output signal, and means for switching among a set of differing determinations of the indication of error. Switching among the differing determinations may be based upon a variety of indications of the progress of adaptation in the equalizer.

Other features and advantages of the present invention will be apparent from the detailed description that follows.

BRIEF DESCRIPTION OF THE DRAWINGS

The present invention is described with respect to particular exemplary embodiments thereof and reference is accordingly made to the drawings in which:

FIG. 1 illustrates a demodulator which includes a blind adaptive equalizer that switches among differing adaptation methods;

FIG. 2 illustrates an error signal selector in one embodiment of the blind adaptive equalizer;

FIG. 3 is a diagram that shows the state transitions of a state machine in the error signal selector in one embodiment;

FIG. 4 illustrates elements of the coefficient generator.

DETAILED DESCRIPTION

FIG. 1 illustrates a demodulator **10** which includes a blind adaptive equalizer **14** that switches among differing adaptation methods. The demodulator **10** also includes a set of signal processing elements **12** and a decision circuit **16**. In one embodiment, the demodulator **10** is a 64-QAM demodulator which is characterized by a set of **64** constellation points each representing a symbol.

The signal processing elements **12** receive an information signal **20** which has been transported via a communication channel or a communication network. The communication channel or network may be embodied in one or more of a variety of physical communication paths including transmission line networks and broadcast communication channels. In one embodiment, the information signal **20** is received via an RF amplifier and associated circuitry which are coupled to a cable network.

The signal processing elements **12** perform a variety of signal processing functions to provide an input signal **22** for the equalizer **14**. In one embodiment, the signal processing elements **12** include an analog-to-digital converter, an automatic gain control, a matched filter, and a timing recovery function, as well as other signal processing elements.

A filter **30** generates a filter output signal **24** in response to the input signal **22**. In one embodiment, the filter **30** is a digital filter. In another embodiment, the filter **30** is a discrete time filter.

The relationship between the filter output signal **24** and the input signal **22** is defined by a transfer function associated with the filter **30**. The transfer function of the filter **30** is controllable and may be adjusted by the modification of a set of filter coefficients **50** which are generated by a coefficient generator **32**.

The decision circuit **16** generates an output signal **26** and an output signal **27** in response to the filter output signal **24**.

The output signal 27 is phase corrected and the output signal 26 is not phase corrected. The decision circuit 16 generates the phase-corrected output signal 27 by performing carrier recovery on the filter output signal 24 and selecting from among a set of predetermined constellation points which best match the symbols carried by the filter output signal 24. The output signal 26 is the phase-corrected output signal 27 with phase correction removed. The predetermined constellation points are each represented by a complex number. Each predetermined constellation point has a real component and an imaginary component.

The coefficient generator 32 adapts the filter 30 to distortions or imperfections in the communication channel over which the information signal 20 was transported by continuously updating the filter coefficients 50 in response to an error signal 52. The coefficient generator 32 updates the filter coefficients 50 according to the following:

$$w_n(k+1)=w_n(k)+e_{SEL}(k+1)y^*(k-n)$$

where k is time, e_{SEL} is the selected error signal 52, n is the filter coefficient number (filter tap number), w_n is the filter coefficient for filter tap n, and $y(k-n)$ is the n^{th} entry in the delay line 66 at time k, and "*" indicates a complex conjugate.

The n filter taps from the filter 30 are provided to the coefficient generator 32 via a set of signal lines 66. In addition to the equation set forth above, there are sign-based adaptation methods for generating updated filter coefficients which may be implemented in the coefficient generator 32.

The error signal 52 is selected from among a set of differing error signals, N error signals in general. In one embodiment, N is 2 and the error signal 52 is selected as either an error signal 60 generated by an error generator 38 or an error signal 62 generated by an error generator 40. The equalizer 14 includes a multiplexer 36 that selects either the error signal 60 or the error signal 62 in response to a control signal 64 generated by an error signal selector 34.

The error generator 38 implements a preselected adaptation method which converges on a circle and is well suited for blind equalizers, i.e. to adaptations which are undertaken when no training symbol sequences are available in the information signal 20. The error generator 38 determines an error in the filter output signal 24 and continuously updates the error signal 60 in response to this error determination. In one embodiment, the error generator 38 performs its error determination according to a constant modulus algorithm (CMA) which is as follows:

$$e_{CMA}(k+1)=\mu_{CMA}(R_2-|Z_k|^2)Z_k$$

where k is time, e_{CMA} is the error signal 60, μ_{CMA} is a step size for the CMA algorithm, R_2 is a constellation dependent constant, and Z_k is the filter output signal 24.

The error generator 40, on the other hand, implements an adaptation method which is decision-directed toward the constellation points for the demodulator 10. The error generator 40 determines an error in the filter output signal 24 and continuously updates the error signal 62 in response to this error determination. In one embodiment, the error generator 40 renders its error determination according to a least mean-square (LMS) determination which is as follows:

$$e_{LMS}(k+1)=\mu_{LMS}(\hat{x}_k-Z_k)$$

where k is time, e_{LMS} is the error signal 62, μ_{LMS} is a step size for the LMS algorithm, \hat{x}_k is the output signal 26, and Z_k is the filter output signal 24.

The error signals 60 and 62 are both indicators of the error between the output signal 26 and the filter output signal 24. The process by which the adaptive equalizer 14 adjusts the transfer function of the digital filter 30 in a manner that reduces the error between the output signal 26 and the filter output signal 24 is called convergence. The adaptation method provided by the error generator 38 is selected for its efficiency in converging when relatively large differences exist between the output signal 26 and the filter output signal 24 as is common at the beginning of a convergence operation when no training symbols are available. On the other hand, the adaptation method provided by the error generator 40 is selected for its efficiency in accurately converging when relatively small differences exist between the output signal 26 and the filter output signal 24.

The error signal selector 34 generates a set of status conditions and uses the status conditions to switch between the error signals 60-62, where appropriate, to properly converge the adaptive equalizer 14 and compensate for the distortions in the input signal 22 which may have been caused by imperfections in the communication channel over which the information signal 22 was transported. The status conditions generally reflect the progress of a convergence operation being undertaken. The status conditions may reflect one or more thresholds in the signal-to-noise ratio of the demodulator 10. The status conditions may also indicate whether a center tap of the filter 30 is outside of a predetermined range. The status conditions may also indicate the absence of outer rim constellation points. The error signal selector 34 uses the filter output signal 24, the output signal 26, and a center tap signal 54 from the digital filter 30 to determine the status conditions.

FIG. 2 illustrates the error signal selector 34 in one embodiment. In this embodiment, the error signal selector 34 includes a state machine 80 and a set of condition generators 82-86. The state machine 80 switches the control signal 64 to select from among the error signals 60-62 in response to a set of control signals 70-74 which reflect the status conditions for a convergence operation. The control signals 70-74 are generated by the condition generators 82-86.

The condition generator 82 detects false or improper convergence states which may occur where the center tap of the digital filter 30 is too large or too small or in the wrong position. In addition, the condition generator 82 detects when the equalizer 14 is not making progress toward convergence as may be indicated when the center tap of the digital filter 30 drifts outside a predetermined range. Any one or more of these conditions may be referred to as a center tap violation (CTV). The condition generator 82 uses the center tap signal 54 from the digital filter 30 to detect a CTV and asserts the control signal 70 to indicate a CTV to the state machine 80 if one of the following conditions is true.

$$\begin{aligned} &(|\text{Re}(C0)| < \text{Cmin}) \text{ AND } (|\text{Im}(C0)| < \text{Cmin}) \\ &(|\text{Re}(C0)| > \text{Cmax}) \text{ OR } (|\text{Im}(C0)| > \text{Cmax}) \end{aligned}$$

where C0 is the complex value of the center tap signal 54, $\text{Re}(C0)$ is the real part of C0, $\text{Im}(C0)$ is the imaginary part of C0, Cmin is the minimum allowed center tap value, and Cmax is the maximum allowed center tap value.

The condition generator 84 uses the filter output signal 24 and the output signal 26 to determine a signal-to-noise ratio (SNR) in the demodulator 10. The signal level for the SNR determination is indicated by the signal power of the output

signal 26 and the noise level for the SNR determination is indicated by the signal power of the difference between the filter output signal 24 and the output signal 26. The condition generator 84 compares the determined SNR to a set of SNR threshold values. These include an upper SNR threshold value, a convergence SNR threshold value, and a loss of convergence SNR threshold value.

The condition generator 84 indicates an Up_Threshold condition on the control signal 72 when the determined SNR is greater than the upper SNR threshold value. The Up_Threshold condition indicates that the adaptation method provided by the error generator 38, CMA in one embodiment, has obtained sufficient convergence to enable a switch to the adaptation method provided by the error generator 40, which in one embodiment is LMS.

The condition generator 84 indicates a Conv_Thresh condition on the control signal 72 when the determined SNR increases above the convergence SNR threshold value. This indicates that the adaptation method provided by the error generator 40 has obtained a high enough SNR in the demodulator 10 for a declaration of convergence by the equalizer 14.

The condition generator 84 indicates an Lconv_Thresh condition on the control signal 72 after the equalizer 14 has converged if the determined SNR dips below the loss of convergence SNR threshold value. The Lconv_Thresh condition indicates a possible loss of convergence in the equalizer 14. The condition generator 84 indicates an #Lconv_Thresh condition on the control signal 72 if the determined SNR rises above the loss of convergence SNR threshold value.

The condition generator 86 detects the lack of outer rim constellation points in the output signal 26. For example, an outer rim constellation point for 64-QAM has a real component value of 3.5 in which case the condition generator 86 detects the lack of real component values of 3.5 in the output signal 26. The condition generator 86 asserts the control signal 74 to indicate a No_Outer_Rim condition if an outer rim value has not been detected within a predetermined number of previous symbols carried by the output signal 26. In one embodiment, the condition generator 86 includes a counter which counts symbols and resets and reloads with a predetermined value whenever an outer rim value occurs. If this counter expires then the No_Outer_Rim condition is generated.

The No_Outer_Rim condition is used by the state machine 80 to prevent a false convergence of the equalizer 14. If a false convergence occurs, the converged constellation is a smaller and noisier version of the actual constellation for the demodulator 10. The lack of outer rim values is an indication of possible convergence to a false constellation.

FIG. 3 is a diagram that shows the state transitions of the state machine 80 in one embodiment. The states of the state machine 80 include a first adaptation method state 100, a second adaptation method state 102, a convergence state 104, and a possible loss of convergence state 106. Also shown are the status conditions as indicated on the control signals 70-74 that cause transitions among the states 100-106.

The state machine 80 enters the first adaptation method state 100 at reset or initialization. While in the state 100, the state machine 80 uses the control signal 64 to select the error signal 60 from the error generator 38 for use by the coefficient generator 32. In one embodiment, this results in the use of the CMA adaptation method when updating the filter coefficients 50. The state machine 80 remains in the first

adaptation method state 100 so that the equalizer 14 uses the error signal 60 to converge until the condition generator 84 signals the Up_Threshold condition. The Up_Threshold condition causes the state machine 80 to transition to the second adaptation method at state 102.

While in the state 102, the state machine 80 uses the control signal 64 to select the error signal 62 from the error generator 40. In one embodiment, this results in the use of the LMS adaptation method when updating the filter coefficients 50. The state machine 80 transitions from the state 102 to the convergence state 104 once the condition generator 84 signals the Conv_Thresh condition. This indicates that the SNR in the demodulator 10 is high enough to declare the convergence of the equalizer 14. On the other hand, the state machine 80 falls back from the state 102 to the state 100 if the condition generator 82 signals the CTV condition or if the condition generator 86 signals the No_Outer_Rim condition.

The state machine 80 includes a first counter which is loaded with a value indicating a maximum number of symbols for which the equalizer 14 will attempt to converge using the adaptation method of the error generator 40 in the state 102. While in the state 102, the state machine 80 decrements the first counter for each symbol. If the first counter expires while in the state 102 then the Terminal_Count_1 condition is indicated and the state machine 80 falls back to the state 100 to restart the convergence process.

In the convergence state 104 the output signal 26 is considered to have good data and the state machine 80 continues to select the error signal 62 to maintain convergence. A CTV or a No Outer Rim indication in the convergence state 104 causes the state machine 80 to fall all the way back to the state 100 to restart the convergence process. While in the convergence state 104, the Lconv_Thresh condition from the condition generator 84 causes the state machine 80 to transition to the possible loss of convergence state 106.

While in the possible loss of convergence state 106, the state machine 80 continues to select the error signal 62 for use by the coefficient generator 32. A subsequent #Lconv_Thresh condition from the condition generator 84 restores the state machine 80 to the convergence state 104. This maintains the use of the more finely tuned adaptation method of the error generator 40 in case the reduced SNR was caused by short term effects on the communication channel that transports the information signal 20.

A CTV condition or a No_Outer_Rim condition causes the state machine 80 to fall out of the possible loss of convergence state 106 to the state 100 to restart the convergence process. The state machine 80 includes a second counter which is loaded with a value indicating a maximum number of symbols for which the equalizer 14 will attempt to re-attain convergence while in the possible loss of convergence state 106. While in the possible loss of convergence state 106, the state machine 80 decrements the second counter for each symbol. If the second counter expires as indicated by the Terminal_Count_2 condition then the state machine 80 transitions to the state 100 to restart the convergence process.

FIG. 4 illustrates elements of the coefficient generator 32. The coefficient generator 32 includes a delay element, an adder, a complex conjugate block, and a multiplier for each of the filter coefficients 50. For generating a filter coefficient 118, the coefficient generator 32 includes a delay element 110 such as a register or flip-flop, an adder 112, a multiplier 114 and a complex conjugate block 115.

The complex conjugate block 115 generates a conjugate of a corresponding filter tap 119. The multiplier 114 multi-

plies the output of the complex conjugate block **115** by the selected error signal **52**. The delay element **110** stores a previous coefficient $w(k)$ and the adder **112** generates an updated coefficient $w(k+1)$ by adding the previous coefficient $w(k)$ to the output of the multiplier **114**. The output of the delay element **110** provides the filter coefficient **118** for the corresponding filter tap **119**.

The filter **30** may be implemented in a variety of arrangements including a simple feed-forward filter and a filter having feed-forward and feed-back elements. In one embodiment, the filter **30** includes a feed-forward filter from the input signal **22** and a feed-back filter from the output signal **26**. The outputs of the feed-forward and feedback filter are summed to provide the filter output signal **24**. The center tap signal **54** is the last tap in the feed-forward filter.

The foregoing detailed description of the present invention is provided for the purposes of illustration and is not intended to be exhaustive or to limit the invention to the precise embodiment disclosed. Accordingly, the scope of the present invention is defined by the appended claims.

What is claimed is:

1. An adaptive equalizer for a demodulator, comprising: filter that generates a filter output signal in response to an information signal according to a set of coefficients for the filter;

means for continuously updating the coefficients in response to an indication of error in the filter output signal;

means for switching among a set of differing determinations of the indication of error while continuously updating the coefficients wherein the means for switching switches among the differing determinations in response to a status indication in the demodulator and wherein the status indication is based upon a determination of whether a center tap signal from the filter exceeds a set of predetermined boundaries.

2. An adaptive equalizer for a demodulator, comprising: filter that generates a filter output signal in response to an information signal according to a set of coefficients for the filter;

means for continuously updating the coefficients in response to an indication of error in the filter output signal;

means for switching among a set of differing determinations of the indication of error while continuously updating the coefficients wherein the means for switching switches among the differing determinations in response to a status indication in the demodulator and wherein the status indication is based upon a detection of a lack of an outer rim constellation point in an output signal of the demodulator.

3. An adaptive equalizer for a demodulator, comprising: filter that generates a filter output signal in response to an information signal according to a transfer function for the filter;

a set of error generators each of which provides a differing determination of an indication of error in the filter output signal;

circuit that switches among the error generators to provide a selected indication of error;

coefficient generator that continuously generates updated filter coefficients that adjust the transfer function of the filter in response to the selected indication of error;

wherein the circuit that switches comprises a multiplexer that selectively couples the indications determined by

the error generators to the coefficient generator and a status condition generator that generates a status condition indicating progress in adapting the filter and a state machine that causes the multiplexer to switch among the indications from the error generators in response to the status condition and wherein the status condition indicates whether a center tap signal from the filter exceeds a set of predetermined boundaries.

4. An adaptive equalizer for a demodulator, comprising: filter that generates a filter output signal in response to an information signal according to a transfer function for the filter;

a set of error generators each of which provides a differing determination of an indication of error in the filter output signal;

circuit that switches among the error generators to provide a selected indication of error;

coefficient generator that continuously generates updated filter coefficients that adjust the transfer function of the filter in response to the selected indication of error;

wherein the circuit that switches comprises a multiplexer that selectively couples the indications determined by the error generators to the coefficient generator and a status condition generator that generates a status condition indicating progress in adapting the filter and a state machine that causes the multiplexer to switch among the indications from the error generators in response to the status condition and wherein the status condition indicates a lack of an outer rim constellation point in an output signal of the demodulator.

5. A method for adapting an equalizer in a demodulator, comprising the steps of:

generating a filter output signal in response to an information signal according to a transfer function having a set of coefficients;

generating a set of indications of error in the filter output signal, each indication based upon a differing determination of error in the filter output signal;

generating a selected indication of error by switching among the indications of error;

continuously updating the coefficients in response to the selected indication of error;

wherein the step of switching among the indications comprises the steps of generating a status condition indicating progress in adapting the filter output signal and switching among the indications in response to the status condition and wherein the step of generating a status condition includes the step of determining whether a center tap signal associated with the transfer function exceeds a set of predetermined boundaries.

6. A method for adapting an equalizer in a demodulator, comprising the steps of:

generating a filter output signal in response to an information signal according to a transfer function having a set of coefficients;

generating a set of indications of error in the filter output signal, each indication based upon a differing determination of error in the filter output signal;

generating a selected indication of error by switching among the indications of error;

continuously updating the coefficients in response to the selected indication of error;

wherein the step of switching among the indications comprises the steps of generating a status condition

9

indicating progress in adapting the filter output signal and switching among the indications in response to the status condition and wherein the step of generating a status condition includes the step of detecting a lack of

10

an outer rim constellation point in an output signal of the demodulator.

* * * * *