



US006161854A

# United States Patent [19]

[11] Patent Number: **6,161,854**

Christini et al.

[45] Date of Patent: **\*Dec. 19, 2000**

[54] **TWO-WHEEL DRIVE BICYCLE**

[75] Inventors: **Steven James Christini; Michael J Dunn**, both of Philadelphia, Pa.; **Louis J Allora**, Morristown, N.J.; **Robert L Pigeon**, Conshohocken, Pa.; **Jeremy T. Shook**, Waipahu, Hi.

[73] Assignee: **Christini Technologies, Inc.**, Philadelphia, Pa.

[\*] Notice: This patent is subject to a terminal disclaimer.

[21] Appl. No.: **09/171,742**

[22] PCT Filed: **Apr. 25, 1997**

[86] PCT No.: **PCT/US97/06181**

§ 371 Date: **Oct. 23, 1998**

§ 102(e) Date: **Oct. 23, 1998**

[87] PCT Pub. No.: **WO97/41024**

PCT Pub. Date: **Nov. 6, 1997**

### Related U.S. Application Data

[60] Provisional application No. 60/016,232, Apr. 26, 1996.

[51] Int. Cl.<sup>7</sup> ..... **B62M 1/00**

[52] U.S. Cl. .... **280/230; 74/665 F**

[58] Field of Search ..... 280/230, 210; 180/223, 224, 240; 74/665 E, 664 R, 665 F

### [56] References Cited

#### U.S. PATENT DOCUMENTS

4,029,332	6/1977	Davis	280/234
4,397,369	8/1983	Read	180/205
4,479,660	10/1984	Patterson	280/261

4,611,684	9/1986	Geschwender	180/223
4,773,662	9/1988	Phillips	280/234
4,895,385	1/1990	Becoat	280/259
5,004,258	4/1991	Becoat	280/259
5,042,608	8/1991	Horiike	180/219
5,052,705	10/1991	Ringle	280/212
5,054,572	10/1991	Parker	180/224
5,113,964	5/1992	Yamauchi	180/224
5,116,070	5/1992	Becoat	280/259
5,158,314	10/1992	Pinos	280/259
5,184,838	2/1993	Becoat	280/259
5,224,725	7/1993	Erlston	280/259
5,253,889	10/1993	Kaminski	280/230
5,324,057	6/1994	Chartrand	280/261
5,332,244	7/1994	Turner	280/230
5,390,946	2/1995	Spicer	280/259
5,397,142	3/1995	Schwarzenbacher	280/260
5,542,689	8/1996	Chalfant	280/242.1

### FOREIGN PATENT DOCUMENTS

0 445 841 B1	11/1994	European Pat. Off.	B62M 17/00
0697329	2/1996	European Pat. Off.	B62M 23/00
0 564 523 B1	6/1996	European Pat. Off.	B62M 17/00
WO 93/09992	5/1993	France	B62M 11/14
1284821	8/1972	United Kingdom	B62K 11/00

*Primary Examiner*—Kevin Hurley

*Assistant Examiner*—Andrew J. Fischer

*Attorney, Agent, or Firm*—Cooley Godward LLP

### [57] ABSTRACT

The present invention is a fully functioning two-wheel drive bicycle (78). The drive train which supplies power to the front wheel (17) is incorporated into a modified frame (91) and comprises a rear wheel (90) driven by the traditional chain or shaft mechanism (23) and the front wheel driven (17) by a series of rigid shafts transferring power from the driven rear wheel (90) to the front wheel (17).

**17 Claims, 11 Drawing Sheets**

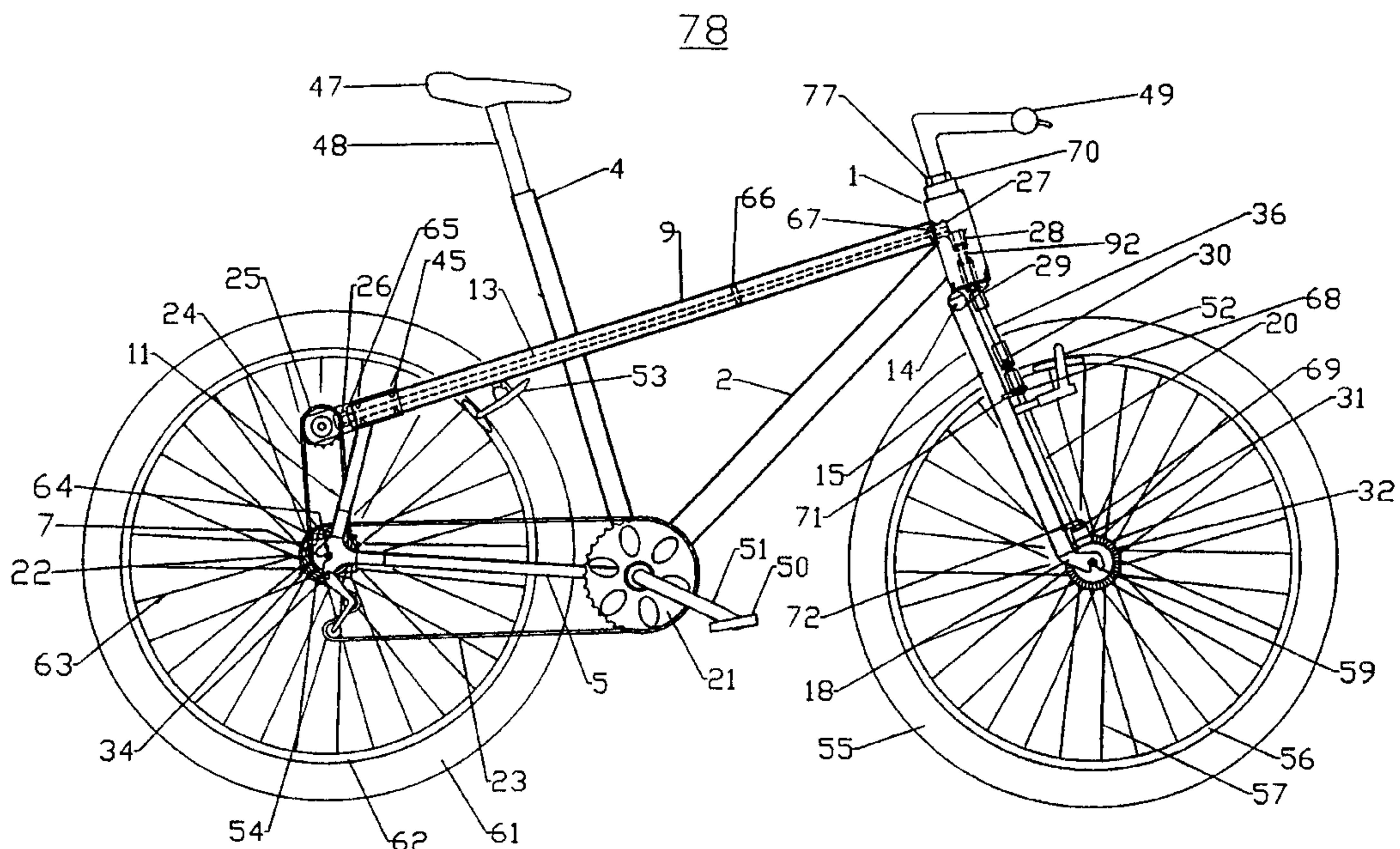

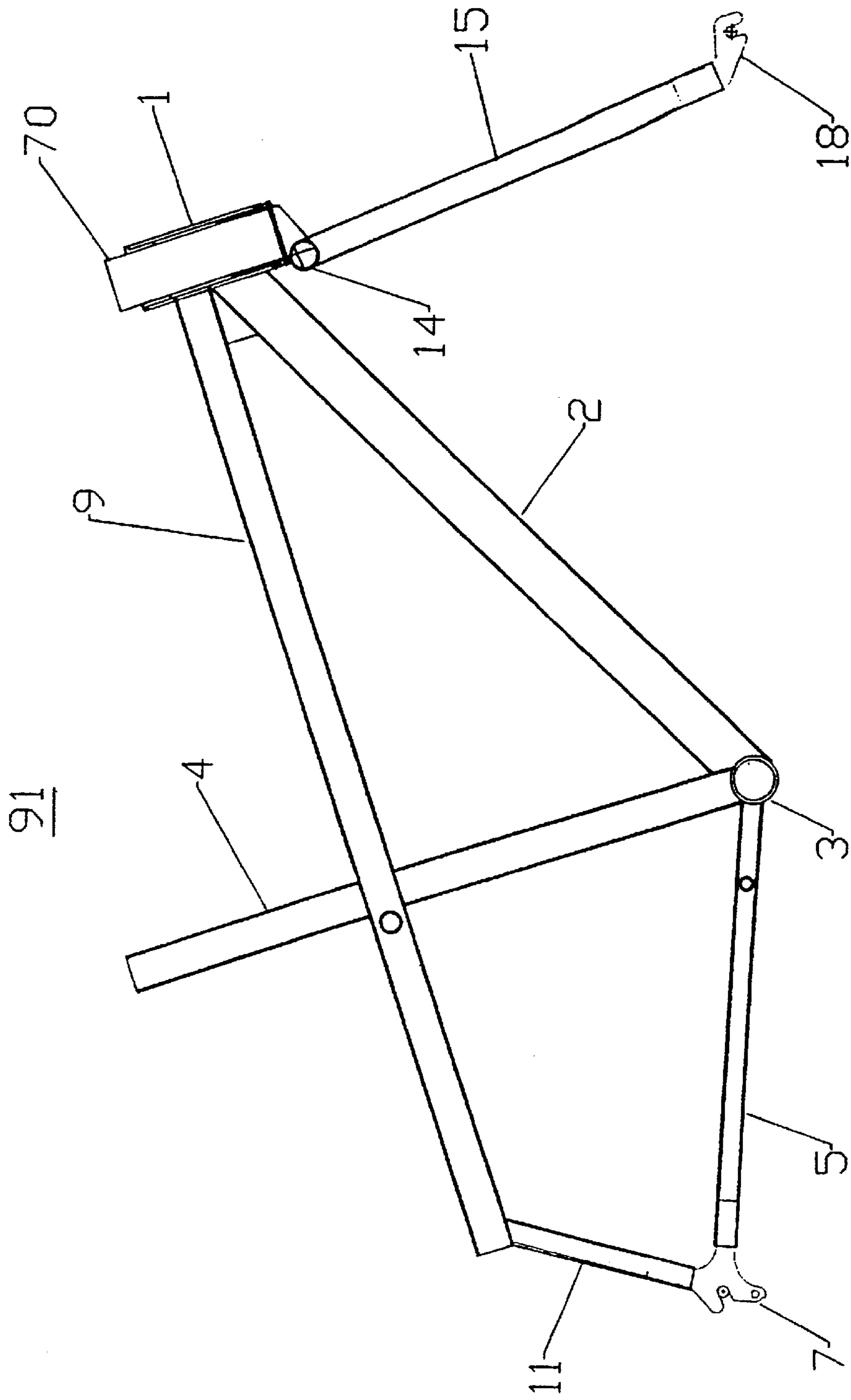

FIG. 1

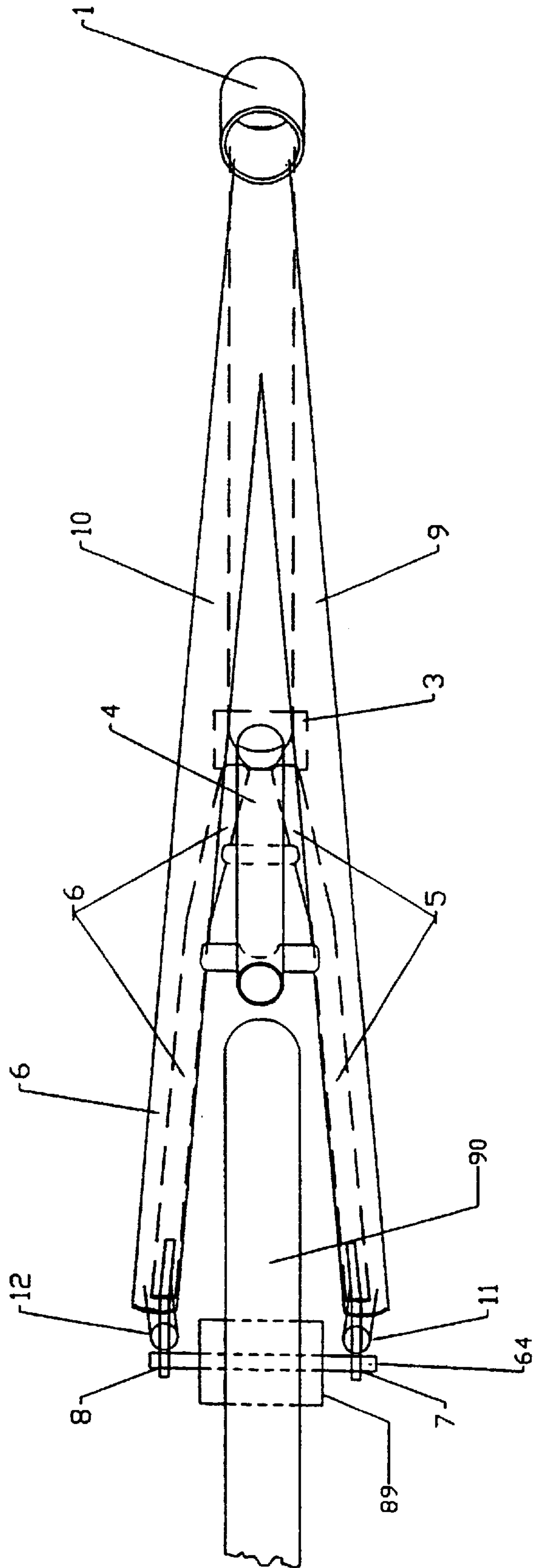

FIG. 2

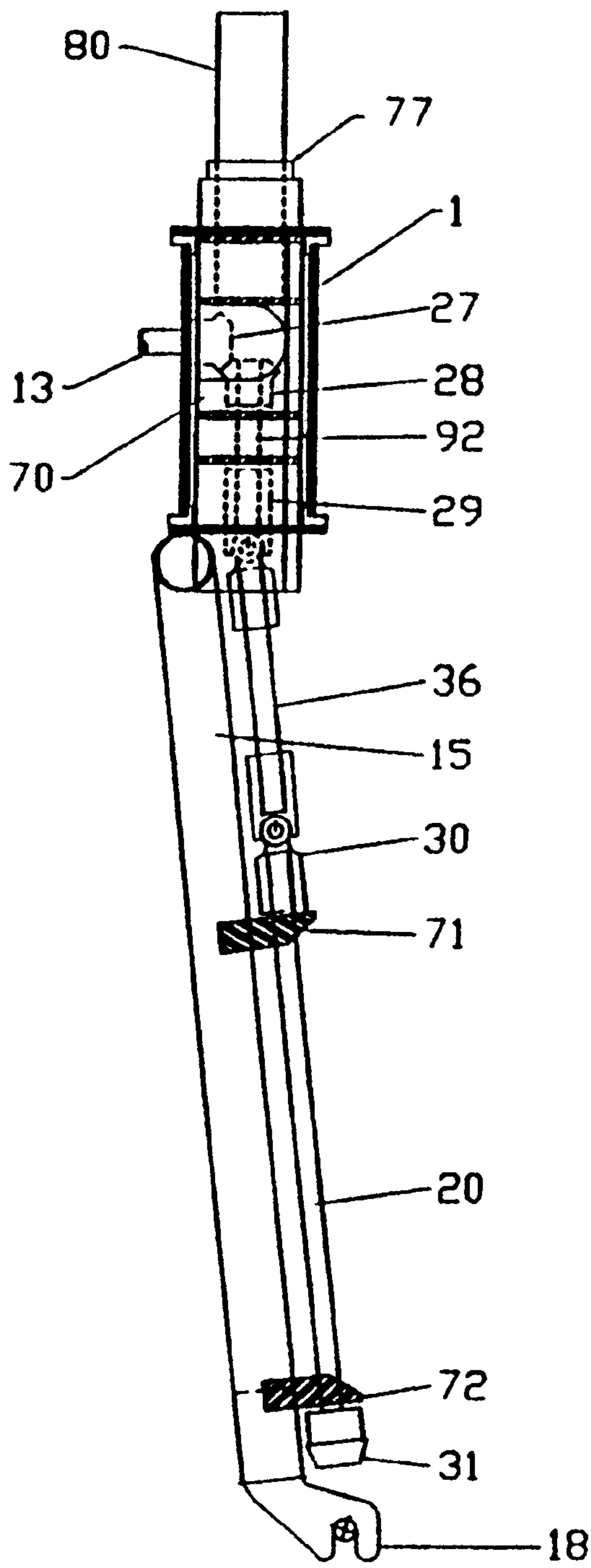

Fig. 3





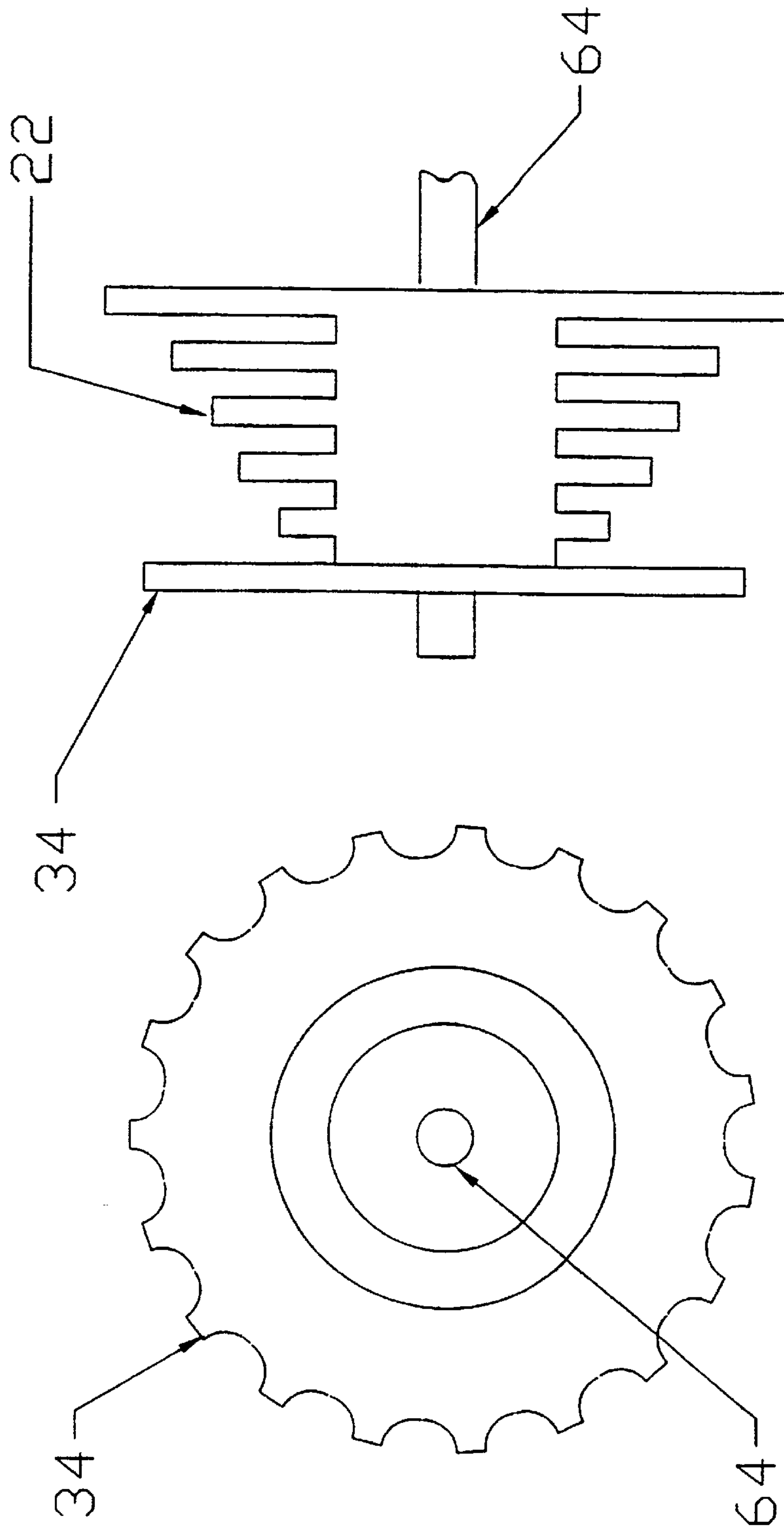

FIG. 5  
FIG. 6

FIG. 7

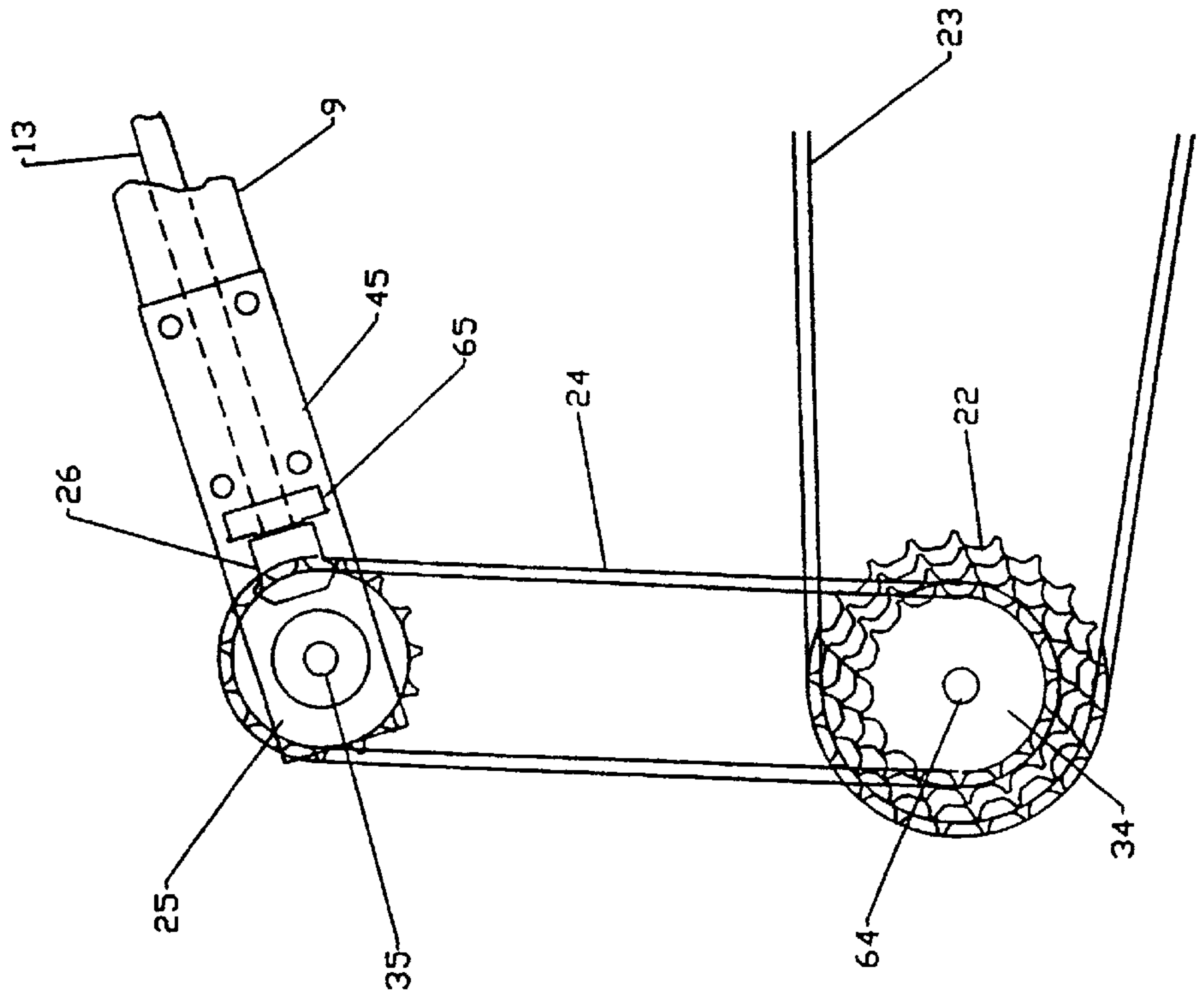
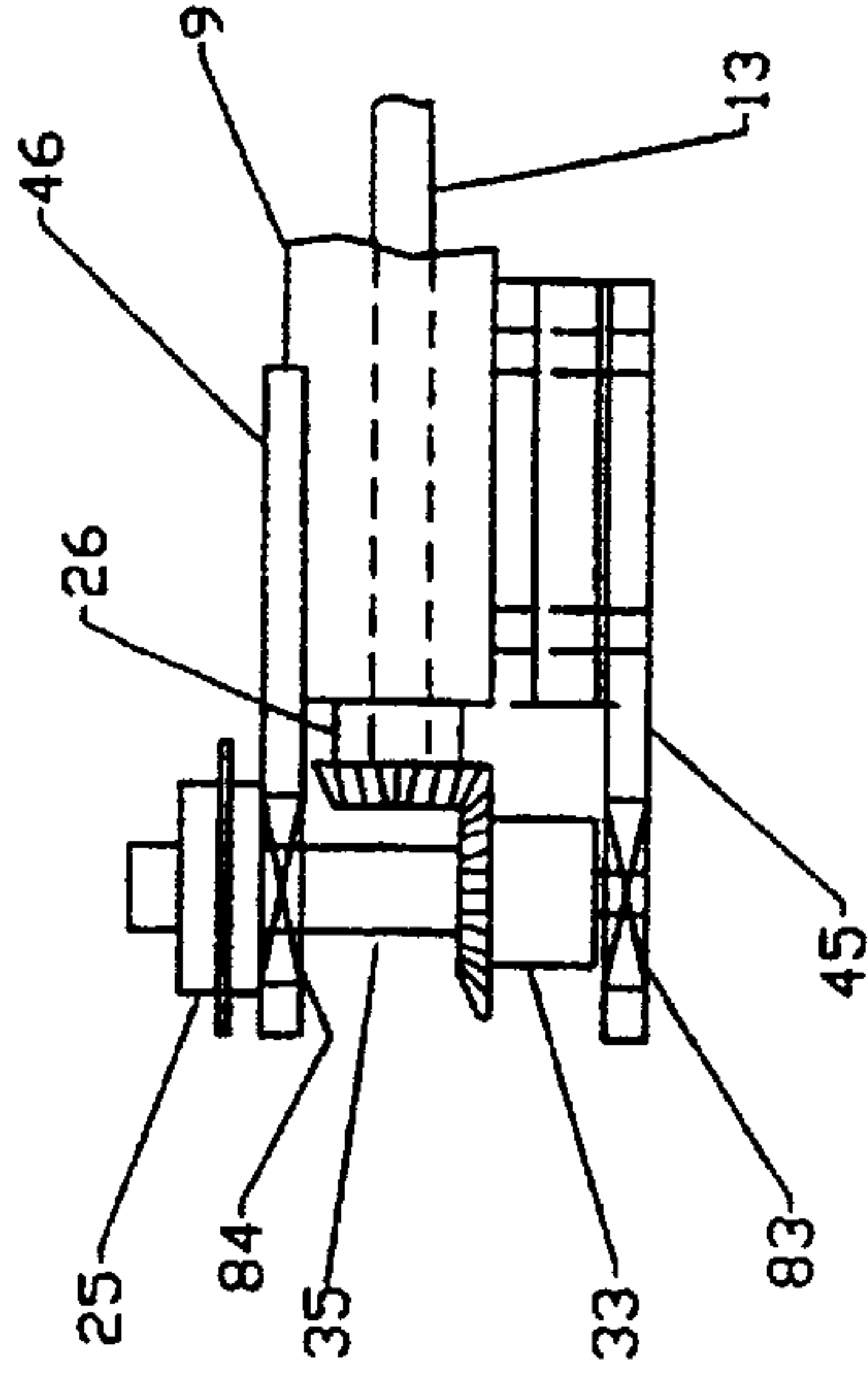

FIG. 8



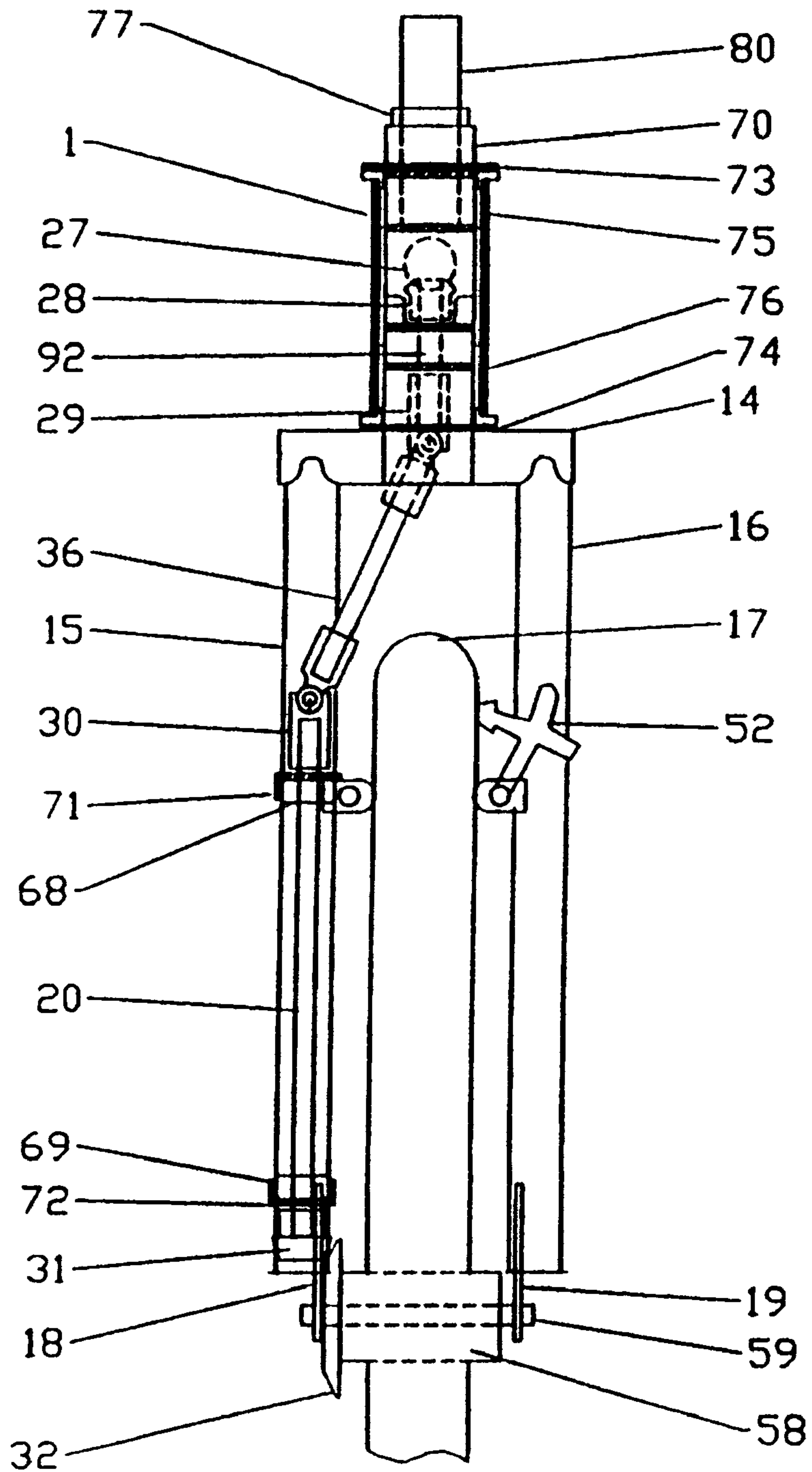

Fig. 9



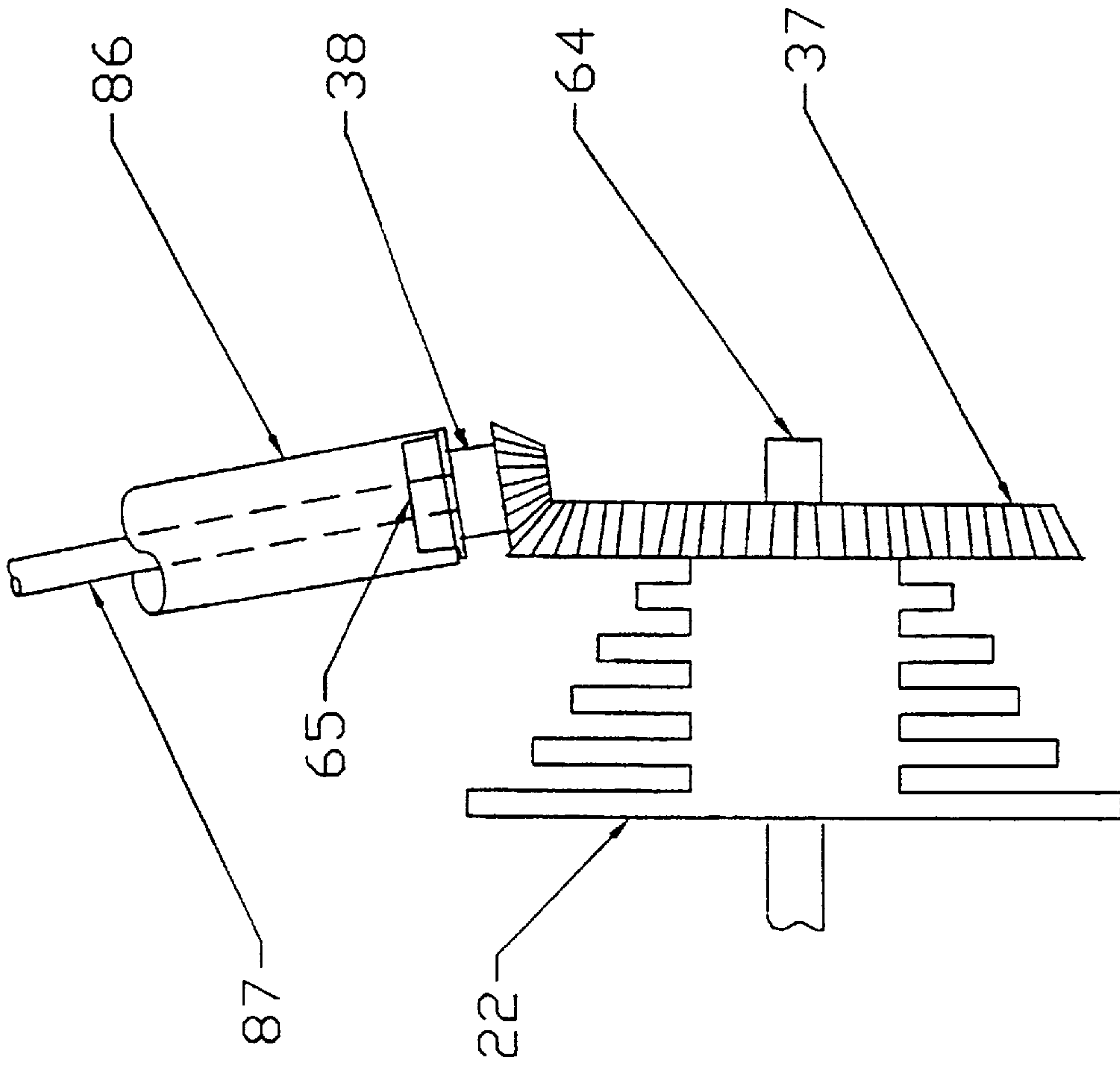

FIG. 10









**TWO-WHEEL DRIVE BICYCLE**

This application relates to and claims priority to U.S. Provisional patent application Ser. No. 60/016,232 entitled Two Wheel Drive Bicycle filed in the United States Patent and Trademark Office on Apr. 26, 1996.

**BACKGROUND OF THE INVENTION**

## 1. Field of the invention

This invention relates to two wheel bicycles, and in particular to two wheel drive bicycles having the rear wheel driven by the traditional chain or shaft mechanism and the front wheel driven by a series of shafts transferring power from the driven rear wheel to the front wheel.

## 2. Description of the Related Art

As off road biking has gained broader appeal, the demands that riders place on their bicycles have increased dramatically. Downhill, snow, and endurance races demand the increased traction and mobility of a two wheel drive bicycle system. Conventional bicycles are powered through a chain linking the pedal crankshaft to the rear wheel. Bicyclists are now facing many obstacles where having only rear wheel drive can lead to bicycle damage or personal injury. For professional riders, precious race time is lost avoiding obstacles such as logs, rocks, loose sand, mud, or ice. Traction and climbing ability are severely limited in extreme mountain conditions by only having the rear wheel provide power. In fact, biking professionals teach that only through learning to keep your weight on the rear wheel will beginners ever hope to improve their off-road skills. Accordingly, there is a need in the industry for a two wheeled drive bicycle which efficiently transfers power from the pedals to the front wheels, provides the rider with increased ability to safely negotiate rough terrain, and which does not detract from the aesthetic qualities and appearances of the bicycle structure itself.

The concept of a two wheel drive bicycle is not a new one. Several two wheel drive bicycle systems are patented at present using various combinations of chains, flexible cable shafts, and rocker arms mounted on the handlebars to transfer power either directly from the pedals to the front wheel or from the rear wheel to the front wheel. In general, two wheel drive bicycle systems fall into two categories: 1) permanent designs involving drive trains attached to the frame, and 2) retrofit kits which convert existing bicycles to two wheel drive. The main drawbacks to these systems are: 1) a modification to the standard bicycle in the form of a kit is expensive when considered as an addition to a bicycle purchase, 2) the low strength flexible shaft limits the allowable loading on the system, 3) the retro-fit kit requires considerable skill to attach and cannot be designed to optimally work with every frame design, and 4) the drive mechanisms are often large and openly exposed on the outside of the frame potentially creating additional hazards for the rider and detracting from the overall appearance of the bicycle.

U.S. Pat. No. 4,773,662 shows a bicycle with a front wheel driven by a chain connected to a handle-bar mounted hand pedaling system. The bicycle uses arm power to drive the front wheels and is adaptable to a conventional bicycle frame.

U.S. Pat. No. 5,542,689 shows a front wheel drive system for a bicycle which can be installed on a bicycle to drive the front wheel by rocking the handlebars back and forth. As with U.S. Pat. No. 4,773,662 mentioned previously, this bicycle attempts to harness the energy of the rider's arms as

an additional power source for driving the bicycle. However, a drive mechanism requiring the use of the riders arms for more than steering, balance and control of the vehicle would likely create serious safety problems and interfere with the bicycle operation for both professional and recreational mountain bikers.

U.S. Pat. No. 5,052,705 describes a bicycle with power distribution from the rear wheel to the front wheel via a caliper and cable drive system. The drive system is activated by a caliper clamped on the rear wheel connected by a cable to a caliper on the front wheel. Inefficient power transfer to the front wheel due to slippage as well as torque loss in the cable would be a problem with this system.

U.S. Pat. No. 5,224,725 describes one permanent system that has been developed utilizing a series of chains and sprockets. This design involved many moving parts that would make the bicycle very awkward and difficult to maintain. The exposed chain that runs along the top tube would be hazardous to the rider and the front chain also would interfere with steering.

U.S. Pat. No. 5,324,057 describes a bicycle driven with a chain meshed with both the front and rear sprockets through a plurality of gears, pulleys and spring systems to power the front wheel.

Several two wheel drive bicycles demonstrate a front wheel driven by flexible cables or flexible cables in combination with chains. (See e.g., U.S. Pat. Nos. 5,332,244, 5,253,889, 5,158,314, 5,116,070, and 4,895,385) The systems, such as the bicycle produced by Turner Drive Systems of Rogers, Ark. target the market for a drive system which can be retrofit to any standard frame with modifications primarily to the gearing and chain attachments necessary to drive the front wheel.

As disclosed, U.S. Pat. No. 5,332,244 uses chain-sprocket arrangements, along with a flexible shaft to transmit some of the power from a rear gearbox to the front wheel. The retrofit system utilizes the inner most sprocket for the drive system, however the rider can use the other sprockets to shift gears normally. Deformation of the flexible cable, and corresponding loss of efficient power transfer from the rear wheel to the front wheel is a drawback of each of these systems when compared to the rigid shaft drive of the present invention.

U.S. Pat. No. 5,158,314 uses a complex mechanical system to power the front wheel from the powered rear wheel. A first traction chain coupled to the rear wheel and attached to the frame is connected to a series of rigid and flexible shafts which attach to a second traction chain which is mounted above the front wheel and powers the front wheel. U.S. Pat. No. 4,029,332 and U.S. Pat. No. 4,474,660 also describe two wheel drive bicycles with complex chain or belt drive and pulley systems. It is, therefore, the object of this invention to provide a two wheel drive bicycle which is powered by a rigid shaft drive system and, therefore, does not experience the loss of power due to slippage or elasticity associated with flexible shafts and other drive systems.

It is a further object of this invention to provide a two wheel drive bicycle wherein the rigid drive shaft system powers the front and rear wheels simultaneously in a ratio which enables safe and effective operation of a the bicycle and provides immediate transfer of power from the pedals to the front wheel.

It is a further object of this invention to construct the bicycle frame in a manner that substantially encloses the shaft drive system and provides effective two wheel drive bilking with no interference of rider motion, with normal braking and steering radius, and with minimal rider danger with respect to moving parts and obstruction of operation.



Other objects and advantages will be more fully apparent from the following disclosure and appended claims.

#### SUMMARY OF THE INVENTION

This application relates to and claims priority to U.S. Provisional patent application Ser. No. 60/016,232 entitled Two Wheel Drive Bicycle filed in the United States Patent and Trademark Office on Apr. 26, 1996. Said Provisional Patent Application is, therefore, incorporated by reference in its entirety.

The present invention is a two wheel drive bicycle, otherwise known as an all wheel drive bicycle or a bicycle powered by both the rear and the front wheels simultaneously. A two wheel drive bicycle provides a rider increased safety and the ability to significantly increase speed during navigation through dangerous stretches of terrain.

The present invention, as described in the preferred and second embodiments, has several objectives. The first is to create a two-wheel drive bicycle using a rigid shaft drive as the main power transfer means to the front wheel. Rigid shafts have the advantage of virtually instantaneous power transfer, whereas flexible shafts usually have from 10 to 20 degrees of rotation displacement when applied with a torque which would lead to a spongy feeling when pedaling the bicycle. Essentially, the rider could turn the pedal several inches before the front wheel would begin to turn.

Secondly, the drive system of the two wheel drive bicycle is substantially incorporated into the frame. Alternatively, the drive system should be enclosed in a tube which is attached to the frame. The primary reason for enclosing the shaft is to maintain the shaft in a fixed position thereby minimizing or eliminating slippage and, as importantly, enclosing the moving parts to minimize danger to the rider. Permanently enclosing the drive system will also avoid the costly, time consuming and often bulky modifications necessitated in configuring the retrofit two wheel drive models while also maintaining the general aesthetic appearance of a standard bicycle.

Third, both the front and back wheel of the bicycle are designed to accommodate a system of sprockets or bevel gears. The rear wheel transmits torque to the front drive means through the shaft either by using a power transfer means at the rear wheel comprising a bevel gear mounted on the rear drive sprocket set which directly interacts; with the pinion gear on the drive shaft, or in the alternative, as described in the preferred embodiment, a drive sprocket mounted concentrically with the rear drive gear system which drives a second chain to a second sprocket and bevel gear system and engages the pinion gear on the drive shaft at a suitable distance from the rear wheel. The power is transferred from the drive shaft system to the front wheel by a pinion gear engaging with a bevel gear mounted on the axle of the front wheel.

Fourth, the neck and head tubes of the bicycle frame are designed to accommodate a pair of meshing miter gears with one being attached to the front end of the main drive shaft and the other being attached to the top end of the front drive shaft system which descends to the front wheel. The enlarged head and neck tubes are necessary to enable the miter gear system to mesh at an angle of approximately 90 degrees while enabling an optimum head angle for steering responsiveness. Furthermore, the head and neck tubes should be modified to enable a turning radius of the front wheel of at least 180 degrees.

Fifth, the frame of the bicycle is modified into a split configuration to enable a straight path for the drive shaft

from the rear of the bike to the head and neck tubes. However, any frame configuration which substantially incorporates the rigid drive shaft system into the frame from the vicinity of the rear wheel to the head tube and down the front fork of the bicycle is envisioned. The frame should be made of aluminum alloy, although other materials could serve equally well depending upon the target market and price.

Sixth, the drive shaft descending from the neck of the bicycle to the front axle should be configured to enable both free motion in the steering of the bicycle and free rotation of the front tire as well as no interference with braking. In the preferred embodiment, a pair of universal joints were used to negotiate clearance by the rigid shafts around the front wheel. Other mechanisms and gear combinations are also envisioned.

Seventh, the preferred and second embodiments utilize a chain connecting the rear wheel to a bevel gear which engages the pinion gear at the rear end of the drive shaft above the axle. However, an alternative embodiment connects the pinion gear on rear the end of the drive shaft directly to a bevel gear mounted concentrically on the rear drive gears.

Thus, according to the broad aspects of the invention, the two wheel drive bicycle comprises:

- (a) a rigid shaft drive system that transmits power from the rear wheel to the front wheel through a series of rigid drive shafts including a main drive shaft and a front drive shaft system and a series of meshing bevel, pinion and miter gears;
- (b) a frame constructed of tubing, including sections which enclose the shaft drive system and which is integral with or a part of the bicycle frame;
- (c) a neck and head designed to accommodate the drive shaft system in a manner that maintains optimum head angle and permits an adequate turning radius.
- (e) a front drive shaft descending to the front wheel configured to enable both free motion in the steering of the bicycle and free rotation of the front wheel without interfering with braking.

In summary, in the present invention, the power is transferred from the pedals to the rear wheel and then to the front wheel through a rigid drive shaft system including a series of meshing gears. The frame of the bicycle is designed to contain the drive shaft that transmits power to the front wheel and is significantly redesigned. In order to have a straight path from the rear sprockets to the neck, the main frame tube is split into two tubes that run directly from the neck to a position approximately seven inches above the rear wheel axle or in the alternative, directly to a bevel gear mounted on the rear wheel. The neck tube is designed to be significantly larger than existing bicycles so it can house the miter gear mechanism.

The power is transmitted from the rear wheel through a rear drive system assembly including a modified rear drive sprocket to a second drive sprocket seven inches above by a short chain. A pair of brackets mounted on the frame rotationally secure the second drive sprocket and a rear bevel gear in position to mesh with a pinion gear at the rear end of the main drive shaft ensuring constant connections and no slippage during power transmission. An alternative drive assembly for transfer of the power from the rear wheel to the main shaft involves the extension of the drive shaft directly to the rear wheel assembly wherein the pinion gear at the end of the drive shaft meshes with a bevel gear mounted circumferentially on the rear drive gears. In still



another alternative, the rear drive system assembly described could be replaced by a short rear drive shaft and bevel gear assemblies.

At the front end, the main drive shaft connects to a miter gear system which is located inside the front head tube of the bicycle. The neck and head tube is enlarged in comparison to a standard bicycle to allow for full steering capabilities of the bicycle while transferring power to the front wheel. The miter gears as shown are connected to a short shaft within the neck tube, to one or more universal joints which are then connected to a front rigid drive shaft system. The purpose of this configuration is to allow the rigid front shaft system to negotiate around the front tire and to allow free motion of the wheel for both rotation and steering. Alternative configurations which would ensure that the front drive shaft does not interfere with steering or rotation of the front wheel are anticipated. One such alternative would reduce the number of components to a single front drive shaft. Another such alternative would utilize a single piece composed of a pair of interconnected universal joints of appropriate length with the miter gear at one end and the front drive shaft at the other end. Those skilled in the art will recognize other methods for constructing a front shaft system which does not interfere with the front wheel and the methods disclosed are not to be construed as limiting.

The front drive shaft transmits power to the front wheel through the interface of a pinion gear attached to the lower end of the front shaft and a bevel gear mounted circumferentially on the front wheel hub. The front wheel hub should be a ratcheting hub which catches in one direction but freewheels in the other direction to enable the rider to coast without the pedals turning.

The applicants believe that this design, as disclosed and broadly interpreted, creates a much sturdier and effective two wheel drive bicycle which is easier to operate. The increased traction and mobility in off road situations resulting from this two wheel drive system is an advance in two wheel drive bicycle technology. Other aspects and features of the invention will be more fully apparent from the following disclosure and appended claims.

#### DESCRIPTION OF THE DRAWINGS

FIG. 1 is a right side view of the preferred embodiment of the main elements of the frame;

FIG. 2 is a top view of the main elements of the bicycle frame;

FIG. 3 is a side view of the front fork assembly with a cut away of the head tube revealing the neck tube and other head tube components;

FIG. 4 is a view of the preferred embodiment of the bicycle drive system;

FIG. 5 is a view of the modified drive sprocket;

FIG. 6 is a view of the modified rear sprocket assembly for the preferred embodiment;

FIG. 7 is a view of the preferred embodiment of the rear drive assembly;

FIG. 8 is a view of the preferred embodiment of the rear drive assembly;

FIG. 9 is a front view of the front fork;

FIG. 10 is a view of the second embodiment of the modified rear sprocket assembly;

FIG. 11 is a view of the second embodiment of the rear drive assembly;

FIG. 12 is a view of the two wheel drive bicycle as described in the preferred embodiment;

FIG. 13 is a view of the two wheel drive bicycle as described in the second embodiment.

#### PREFERRED EMBODIMENT OF THE INVENTION

The present invention comprises a two wheel drive bicycle 78 having many of the same standard bicycle components such as seat 47, seat stem 48, handlebars 49, a right pedal 50, a left pedal (not shown), a pedal crank shaft 51, a front brake 52, a back brake 53, and a derailleur 54 which are not modified in this invention and which are well known in the art. Additionally, the front wheel 17 when used in this description includes the front tire 55, front wheel rim 56, front spokes 57, and front wheel hub 58, all of which are well known to one skilled in the art. Similarly, the rear wheel 90, when used in this specification includes the rear tire 61, the rear wheel rim 62, the rear spokes 63, the rear wheel hub 89, and the rear drive sprockets 22, all of which are well known to one skilled in the art.

Referring now to the drawings of the frame, FIGS. 1, 2, 3, 9, and 12 show the frame design of the preferred embodiment of the two wheel drive bicycle 78. The frame 91 comprises a single head tube 1, connecting a single down tube 2, which connects at the crank tube 3, with the seat tube 4, a right chain stay 5, a left chain stay 6 which then terminate with a right rear dropout 7 and a left rear dropout 8, respectively. The main drive tube 9 and the main frame tube 10 form a dual horizontal tube construction beginning at the head tube 1 at the front of the frame 91 and extending rearward where the main drive tube 9 connects to a right rear support tube 11 and the main frame tube connects to a left rear support tube 1. The right rear support tube 11 connects the rear end of the main drive tube 9 with the right chain stay 5 at the right rear drop out 7 and the left rear support tube 12 connects the rear end of the main frame tube 10 with the left chain stay 6 at the left rear drop out 8. As is well known in the art, the rear wheel 90 is mounted rotationally on the rear axle 64 between the right rear dropout 7 and the left rear dropout 8.

As shown in FIG. 12, the main drive tube 9 contains the main drive shaft 13 of the two wheel drive bicycle 78. The main drive shaft 13 is supported within the main drive tube 9 by a rear drive shaft roller bearing 65, a center drive shaft roller bearing 66, and a front drive shaft roller bearing 67 to ensure smooth rotation and minimize wobble. As is well known in the art, the main drive tube 9 could be custom designed to accommodate various size main drive shaft and bearing combinations.

The frame 91 configuration of the two wheel drive bicycle 78 includes two notable changes when compared to the standard diamond shaped bicycle frame. First, the head tube 1 is significantly enlarged in order to house the first miter gear 27 and the second miter gear 28. A standard bicycle head tube is usually only 1 to 1.25 inches (25.4 to 31.75 mm) in diameter. The head tube 1 of the bicycle 78 utilizes a 2 inch (50.8 mm) diameter tube. The second modification is the use of a pair of horizontal tubes, the main drive tube 9 and the main frame tube 10 on the right and left sides of the bicycle 78 respectively, which are also mounted lower on the seat tube 4 than a single horizontal frame tube would be on a standard bicycle frame.

The main considerations for the design of the head tube 1 and the positioning of the main drive tube 9 and the main frame tube 10 is the effective transfer of power from the rear drive sprockets 22 through the main drive tube 9, through the head tube 1, and down to the front bevel gear 32 to drive



the front wheel **17** in an effective manner which will not interfere with steering, pedaling or tire clearance and result in an appropriate front fork angle necessary for rider safety and control. The wheel base of the bicycle **78**, measured as the distance between the front axle **59** and rear axle **64**, is 39 inches (0.99 m). The clearance measurement, determined as the height of an obstacle that the bicycle will be able to ride over without it striking the crank tube **3**, is 9 inches (0.23 m) and is comparable to other bicycles for off road use. Finally, for optimal control, a safe head tube and front fork assembly angle for a mountain bike is between 70 and 74 degrees. As shown, the angle of the head tube **1** is 71 degrees which was accomplished by raising the main drive tube **9** and main frame tube **10** approximately 7 inches (177.8 mm), or the length of the right rear support tube **11** and the left rear support tube **12**, respectively. Other longer or shorter wheel base clearance dimensions or head tube angle may be appropriate for a two wheel drive bicycle and are well known to those skilled in the art. An alternative design for achieving optimum angle of the head tube **1** is disclosed in the second embodiment of the two wheel drive bicycle **79**.

Though, the frame **91** design represents a key element of the subject invention the drawings presented are not intended to be limiting. While a split frame is demonstrated, any frame design which incorporates the drive train internally from the vicinity of the rear wheel **90** to the forward head tube **1** position of the bicycle then down to the front wheel **17** is envisioned. This structure could take the form of a single tube frame provided the right shaft configuration is designed incorporating the appropriate gears and joints to facilitate the positioning of the drive shaft in the center of the bicycle as compared to being offset on the side of the frame.

FIGS. **3** and **9** illustrate aspects of the bicycle **78** design which encompass the front fork assembly descending from the head tube **1**. The front fork assembly begins with a neck tube **70** located within the head tube **1** and connecting at one end with a front fork post support **14**. The front fork post support **14** connects with the upper ends of the right front fork member **15** and the left front fork member **16** which pass along the sides of the front tire **17**. The right front fork member **15** terminates at the right front dropout **18** and the left front fork member **16** terminates at the left front dropout **19**. The front wheel **17** mounts rotationally on the front axle **59** between the right front dropout **17** and left front dropout **18**. The right fork member **15** holds the front drive shaft **20** in the present embodiment **78**. The front brakes **52** are mounted on the right front fork member **15** and the left front fork member **16** as is well known in the art.

The precision design of the front fork assembly is critical for proper power transmission from the main drive shaft **13** to the front wheel **17** while allowing for a turning radius which gives the rider full steering capabilities and allows for complete control of the bicycle. Rotationally mounted with the head tube **1** and connecting at the lower end with the front fork post support **14**, is a neck tube **70**. The neck tube **70** is constructed of 1.75 inch diameter tubing and contains a cutout portion to enable pivoting around the internal drive shaft system components including a first miter gear **27** and a second miter gear during steering of the bicycle **78**. As shown in FIG. **4**, the neck tube **70** also contains an upper neck roller bearing **81** and a lower neck roller bearing **82** to hold the short connecting drive shaft **92** in place within the neck tube **70** for smooth rotation. Similarly, an upper fork roller bearing **68** and a lower fork roller bearing **69** mounted on the right front fork member **15** support the drive shaft **20** and permit smooth rotation.

The rear drive shaft roller bearing **65**, the center drive shaft roller bearing **66**, and the front drive shaft roller

bearing **67** are pressure fitted to remain fixed in place. The upper neck roller bearing **81** and lower neck roller bearing **82** are held in place by washers welded within the neck tube **70**. The upper fork roller bearing **68** is fixed to the right front fork member **15** by an upper fork bracket **71** and the lower fork roller bearing **69** is fixed to the right front fork member **15** by a lower fork bracket **72**. As is well known in the art, alternative frame designs and embodiments could utilize other means for securing roller bearings in place and the means described are not to be construed as limiting. As is well known in the art, alternative shaft, tube and fork designs could eliminate or reduce the number of necessary roller bearings. Additionally, those skilled in the art would understand configurations of the front fork assembly which could hold the front drive shaft **20** on the left front fork member **16** and the design shown is not to be construed as limiting.

As shown in FIG. **9**, the neck tube **70** is supported within the head tube **1** with means which are well known in the art as being standard on most bicycles. In order to ensure smooth turning of the neck tube **70** an upper head needle bearing **73** and a lower head needle bearing **74** at either end of the head tube **1** encircle the neck tube **70** and support axial loads of the front fork assembly. Additionally, inside the head tube **1**, an upper neck needle bearing **75** and a lower neck needle bearing **76** support the neck tube **70** and keep it from pivoting, thus supporting radial loads. This assembly is tightened up by means of a large nut **77** that is threaded on the steering handle tube **80** at the top of the neck tube **70**.

As shown in FIG. **3**, the neck tube **70** is designed to stay enclosed within the head tube **1**. Additionally, the neck tube **70** has a cutout section to allow clearance during rotation of the neck tube **70** corresponding to the steering of the handlebars **49** around the first miter gear **27** and the second miter gear **28**. In the two wheel drive bicycle **78**, the cutout is 1.25 inches wide and results in a steering radius of 180 degrees. Alternative designs and dimensions for cutouts in the neck tube **70** resulting in varying steering radiuses are anticipated and the dimensions disclosed should not be construed as limiting.

FIGS. **4** and **12** represent the preferred embodiment of the shaft drive system. In a conventional manner, power from the pedals is transmitted directly from the front drive sprocket **21** mounted on the pedal crank shaft **51** to the rear drive sprockets **22** via a chain **23**. The rear drive sprockets **22** are mounted on the rear wheel **90** at the rear wheel hub **89** which is rotationally mounted on the rear axle **64** between the right rear dropout **7** and left rear dropout **8**. As shown in FIGS. **6** and **7**, a modified drive sprocket **34** is mounted concentrically on the outside of the rear sprockets **22**. The modified drive sprocket **34** replaces two of a standard bicycle's **7** rear sprocket gears on the two wheel drive bicycle **78**. However, the number of gears is not an essential aspect of the present invention and is not to be construed as limiting.

As shown in FIG. **7**, power is transferred from the modified drive sprocket **34** through a second drive chain **24** to a second drive sprocket **25**. A rear bevel gear **33** is affixed to the second drive sprocket **25** via a short axle **35** and transmits power through its interface with a rear pinion gear **26** fixed directly to the rear end of the main drive shaft **13**.

The second drive sprocket **25** is fixed proximal to the second rear drive system bracket **46** on the short axle **35** and the rear bevel gear **33** is fixed proximal to the first rear drive system bracket **45** on the short axle **35**. The first rear drive system bracket **45** and the second rear drive system bracket **46** are constructed of 6061 reinforced plate aluminum and



are fixed permanently via bolts and welding directly to the main drive tube **9**. The first rear drive system bracket **45** and the second rear drive system bracket **46** are intended to hold the short axle **35** and the second drive sprocket **25** and the rear bevel gear **33** in a fixed position relative to the frame **91** while enabling them to rotate in unison for power transmission. As disclosed, the modified drive sprocket **34** is a 19 tooth sprocket and the second drive sprocket **25** is a 13 tooth sprocket, however, the number of sprocket teeth on any gear should not be construed as limiting as other sprocket teeth configurations are clearly envisioned.

On the two wheel drive bicycle **78**, the meshing and rotation of the rear bevel gear **33** with the rear pinion gear **26** produces a reaction force laterally along the short axle **35**, therefore, a first short axle roller bearing **83** and a second short axle roller bearing **84** were used to support this loading. This design is conservative to prevent gear displacement and is not considered limiting as those skilled in the art may clearly envision alternative and less bulky bracket and bearing designs for the rear drive system.

As shown in FIGS. **4** and **12** the rotation of the main drive shaft **13** transmits power through the first miter gear **27** fixed on the front end of said main drive shaft **13** to the second miter gear **28**. The first miter gear **27** is mated to the second miter gear **28** at an approximate 90 degree angle within the head tube **1** of the bicycle **78**. The power is then transferred from the second miter gear **28** through a short connecting shaft **92**, a first universal joint **29**, a second short shaft **36**, a second universal joint **30**, a front drive shaft **20** to a front pinion gear **31** mounted on the lower end of the front drive shaft **20**. The front pinion gear **31** meshes with, and transfers power to, a front bevel gear **32** mounted concentrically on the front wheel hub **58**. The front wheel **17** is mounted rotationally to the frame **91** on the front axle **59** between the right front dropout **18** and the left front dropout **19** and is driven by the rotational power of the front wheel hub **58**.

The front wheel hub **58** is a modified freewheeling hub. Said front wheel hub **58** will catch to transmit power in one direction, but spin freely in the other direction meaning the rider can ride without the pedals turning. Such a hub is standard on rear wheels of bicycles but is necessary on the front wheel of the two wheel drive bicycle to allow the front wheel to turn while coasting.

As shown in FIG. **9**, the first universal joint **29** and second universal joint **30** allow for power transmission down and around the front wheel **17** without interfering with normal steering or rotation of the front wheel **17** and, accordingly, are mounted at a 25 degree offset. Any angles which are within manufacturer's specifications are clearly anticipated for the purpose of transmitting power through the first universal joint **29** and second universal joint **30** down and around the front wheel **17**.

Generally, the rear pinion gear **26**, the front pinion gear **31**, the first miter gear **27** and the second miter gear **28** are attached to shaft ends using setscrews and keyways (not shown) and the first universal joint **29** and second universal joint **30** are attached to shaft ends by shear pins (not shown). Use of setscrews and shear pins is appropriate because if the drive system did undergo a shock load, the failure of a shear pin or keyway would insure that there would be no severe damage incurred in any of the other drive system components, which would be more expensive to replace. Alternative connective means for attaching the pinion gears and universal joints to the corresponding shafts are well known by those skilled in the art.

For a two wheel drive bicycle, gear ratios underlying the front to back wheel rotation ratio while being powered by

the pedals are important considerations. For the two wheel drive bicycle **78** the front wheel **17** to rear wheel **90** rotational ratio is 0.9876 to 1.0000, that is, the front wheel **17** turns 0.9876 times for each 1 full rotation of the rear wheel **90**. While it is conceivable to design a bicycle with varying front wheel to rear wheel gearing ratios (e.g., the front wheel turns at a range of 0.90 to 1.10 revolutions for each 1 revolution of the back wheel), in testing, a ratio which would cause the front wheel to turn at a rate equal to the rear wheel, or even at a rate of greater than 1:1 (front wheel to rear wheel ratio) would create a sense of front wheel drive. As described, the ratio of 0.9876:1.0000 provides the rider with good control and handling characteristics. However, the 0.9876:1.0000 ratio is not intended to be limiting for the subject invention, but rather represents the best mode described in the preferred and alternative embodiments described herein. Certain riding conditions, such as up hill racing where a "front wheel drive" sensation would be desirable, may make alternative ratios more desirable (e.g., the front wheel turns 1.10 times for each 1 revolution of the rear wheel). Therefore, the gearing ratios offered are for means of illustration only and should not be construed in any way as limiting since one skilled in the art could easily develop countless alternative gear ratio combinations. Additionally, those skilled in the art will recognize that a strategy of increasing ("stepping up") the revolutions of the shaft through gear ratios, then decreasing ("stepping down") the revolutions of the front wheel will lessen the torque load and enable construction of shaft systems of minimal diameter.

The two wheel drive bicycle **78** achieves the desired 1:0.9876 rotational ratio by powering the front wheel **17** through 0.9876 revolutions for each full revolution of the rear wheel **90** by the interaction, positioning and sizes of the gears as shown in FIG. **4**. The power is transferred from the modified drive sprocket **34**, a 19 tooth sprocket, mounted on the rear drive sprockets **22** through the second drive chain **24** to the second drive sprocket **25**, a 13 tooth sprocket, resulting in a rotational ratio of 1.46:1 ratio. The second drive sprocket **25** rotates simultaneously with the rear bevel gear **33** since both the second drive sprocket **25** and the rear bevel gear **33** are mounted on the short axle **35**. In order to maintain the appropriate rotation needed to power the front wheel **17** in the same direction as the rear wheel **90**, the rear bevel gear **33** is mounted proximal to the first rear drive system bracket **45**. The rear bevel gear **33** mates with the rear pinion gear **26** mounted on the rear end of the main drive shaft **13**. Said rear bevel gear **33** and said rear pinion gear **26** interface provides a 2:1 gear ratio yielding a total ratio to this point of the drive system of 2.92:1. That is, the main drive shaft **13** is now rotating at a rate of 2.92 for each rotation of the modified drive sprocket **34** which is turning at the same rate as the rear wheel **90**. Power transferred from the main drive shaft **13** through the first miter gear **27**, to the second miter gear **28**, through the short connecting shaft **92**, the first universal joints **29**, the second short shaft **36**, the second universal joint **30**, the front drive shaft **20** to the front pinion gear **31** results in an unchanged rotation ratio of 2.92:1. The ratio of the front pinion gear **31** which is meshed with the front bevel gear **32** is 1:3 resulting in the final ratio of rotation between the front wheel **17** and back wheel to be 0.9876:1.

As disclosed the main drive shaft **13**, the short connecting shaft **92**, the second short shaft **36** and the front drive shaft **20** are manufactured of 1/2 inch solid steel shafts. An alternative composition for the solid shafts would be the use of 3/8 inch solid steel shafts. A further alternative would be to



manufacture the shaft of ½ inch hollow steel with slightly over diameter in order to deliver the necessary torque levels while having the benefit of a reduced weight. As is well known in the art, metals and composites other than steel could be used as suitable substitutes for the shafts as long as they provided appropriate drive system strength.

#### SECOND EMBODIMENT OF THE INVENTION

FIGS. 10, 11 and 13 illustrate aspects of a two wheel drive bicycle 79 wherein the modified drive sprocket 34, the second drive chain 24, the second drive sprocket 25 and first rear drive system bracket 45 and the second rear drive system bracket 46 described in the first embodiment of the two wheel drive bicycle 78 are replaced by a rear wheel bevel gear 37 and a drive shaft pinion gear 38 to power the front wheel in an alternative manner.

In the second embodiment of the two wheel drive bicycle 79, the power transmitted to the rear drive sprockets 22 from the pedal crank shaft 51 through the chain 23 is transferred to the rear wheel bevel gear 37 mounted circumferentially on the outer region of the rear drive sprockets 22 to result in simultaneous turning of the rear drive sprockets 22 and the rear wheel bevel gear 37. The rear wheel bevel gear 37 meshes directly with a drive shaft pinion gear 38 to transfer power directly to the straight main drive shaft 87. As shown in FIG. 10, the bevel gear teeth 39 of the rear wheel bevel gear 37 and pinion gear teeth 93 of the drive shaft pinion gear 38 are of a helical design and cut to accept an approximate 4 degree offset. This 4 degrees is necessary to align the straight main drive shaft 87 with the angle of the straight main drive tube 86 from the modified right rear dropout to the head tube 1.

In the second embodiment 79 as shown in FIG. 13, the straight main drive shaft 87 transmits power to the front drive system via a shaft miter gear 88 which interfaces with an upper miter gear 40 which in turn delivers the power to the front wheel 17 through the short connecting shaft 92, the first universal joint 29, the second short shaft 36, the second universal joint 30, the front drive shaft 20, the front pinion gear 31, to the front bevel gear 32 in order to drive the front wheel 17 as was previously described in the preferred embodiment 78. Except for the reversal of the orientation of the upper miter gear 40 to the top side of the shaft miter gear 88, the front drive system remains essentially unchanged in the two embodiments disclosed. Additionally, the use and positioning of rear drive shaft roller bearing 65, the center drive shaft roller bearing 66, and the front drive shaft roller bearing 67 to support the straight main drive shaft 87, remains unchanged in the second embodiment 79.

In the present embodiment 79, the upper miter gear 40 was moved to the upper end of the short connecting shaft 92 to accommodate the reverse rotation of the straight main drive shaft 87 which was necessitated by the placement of the rear wheel bevel gear 37 on the inside of the drive shaft pinion gear 38 since the rear drive sprockets 22 would interfere if the drive shaft pinion gear 38 was placed internal to the rear wheel bevel gear 37. The straight main drive shaft 87 enters into the straight main drive tube 86 of the bicycle 79 immediately after the modified right rear drop out 41 which allows for the straight main drive shaft 87 to extend into the head tube 1 of the bicycle 79. The design of the bicycle 79 is similar to the design discussed in the preferred embodiment 78 except that the straight main drive tube 86 connects directly to the right chain stay 5 at the modified right rear dropout 41 on the right side of the bicycle 79, and a straight main frame tube (not shown) connects directly to

the left chain stay 6 at the left rear dropout (not shown) on the left side of the bicycle 79. Additionally, a right seat support 43 connects the modified right rear dropout 41 to the seat tube 4 on the right side of the bicycle and a left seat support (not shown) connects a left rear dropout on the left side of the bicycle to the seat tube 4 and may be necessary to provide additional support for the weight of the rider. The modified right rear dropout 41 described in the second embodiment 79 has a center section cutout which is necessary to allow proper clearance and alignment of the drive shaft pinion gear 38 attached at the rear end of the straight main drive shaft 87 and extending out from the rear end of the straight main drive tube 86. This cutout also allows for ease of maintenance and cleaning of the system.

In the second embodiment of the two wheel drive bicycle 79, the rear wheel bevel gear 37 is three inches in diameter and the drive shaft pinion gear 38 is specially designed so that the meshing of the rear wheel bevel gear 37 and drive shaft pinion gear 38 transmits power through the drive system to achieve a final rear wheel 90 to front wheel 17 rotational ratio of between 1.00:0.97 and 1.00:0.99. Said design of the drive shaft pinion gear 38 is well known in the art and merely relies upon the ratio of the number of bevel gear teeth 39 to the number of pinion gear teeth 93 to create the final gearing ratio. Additionally, the rear wheel bevel gear 37 is mounted on the low gear side of the rear drive sprockets 22 at a close clearance distance to the rear end of the straight main drive tube 86 of the bicycle 74. This distance is necessary to enable proper alignment of the drive shaft pinion gear 38 on the end of the straight main drive shaft 87 as it meshes with the rear wheel bevel gear 37. The drive shaft pinion gear 38 extends out of the rear end of the straight main drive tube 86 and rests in the center of the modified right rear dropout 41.

In considering this invention, it should be remembered that the present disclosure is only illustrative and the scope of the invention should be determined by the specification which is not intended to be limited to the embodiments disclosed here. This invention successfully discloses both the design and the construction of a two-wheel drive all terrain bicycle. The two wheel drive system dramatically increases traction and mobility, especially during uphill climbs on loose or slippery material. In order to further reduce the weight of the bicycle, a weight reduction could be sought for the drive train components. A hollow rigid main drive shaft capable of transmitting the necessary amount of torque, possibly made out of composites, will significantly reduce the weight. Also, larger but lighter aluminum or composite gears could be used for the front and rear bevel systems. This could mean an overall weight reduction of 3–4 pounds which would make the bicycle's weight extremely competitive. The invention discloses an excellent method of manufacturing a functional two wheel drive bicycle with an attractive design. As envisioned, this fully integrated two wheel drive bicycle would not only compete with the most advanced bicycles on the market, it would create an entirely new category in the industry.

While the foregoing is directed to the preferred and alternative embodiments of the present invention, other and further embodiments of the invention may be devised without departing from the basic scope thereof, and the scope thereof is determined by the claims which follow.

We claim:

1. A two-wheel drive bicycle comprising:
  - a frame, the frame including a head tube;
  - a steering mechanism pivotably attached to the head tube;



## 13

- a front wheel rotatably mounted on the steering mechanism;
- a rear wheel rotatably mounted on the frame;
- a power transfer mechanism including a drive chain mounted on the frame, the power transfer mechanism operable to transmit power from a rider of the bicycle to the rear wheel; and
- a front wheel drive mechanism operating to transmit power from the power transfer mechanism to the front wheel, the front wheel drive mechanism including at least one rigid shaft, and a pair of meshing gears located within the head tube.
2. The two-wheel drive bicycle according to claim 1, wherein the at least one rigid shaft is a first rigid shaft and the front wheel drive mechanism further includes a second rigid shaft assembly operatively connected to the pair of meshing gears and the front wheel.
3. The two-wheel drive bicycle according to claim 2, wherein the second rigid shaft assembly includes at least one universal joint for rotatably transferring power from the pair of meshing gears to the front wheel.
4. The two-wheel drive bicycle according to claim 1, wherein the front wheel drive mechanism further includes a rear gearing system having a drive chain and being operable to transmit power from the rear wheel to the at least one rigid shaft.
5. The two-wheel drive bicycle according to claim 1, wherein the power transfer mechanism includes at least one rear wheel drive sprocket for transmitting power from the drive chain of the power transfer mechanism to the rear wheel, and the at least one rigid shaft includes a gear for transmitting power from the at least one rear wheel drive sprocket to the pair of meshing gears.
6. The two-wheel drive bicycle according to claim 1, wherein the front wheel drive mechanism is configured to transmit power to the front wheel such that the front wheel is underdriven at a ratio of less than one revolution for each revolution of the rear wheel.
7. The two-wheel drive bicycle according to claim 1, wherein the front wheel drive mechanism is configured to transmit power to the front wheel such that the front wheel is overdriven at a ratio of greater than one revolution for each revolution of the rear wheel.
8. The two-wheel drive bicycle according to claim 1, wherein the front wheel drive mechanism is configured to transmit power to the front wheel such that the front wheel is driven at a ratio of 0.9876 revolutions for each revolution of the rear wheel.
9. The two-wheel drive bicycle according to claim 1, wherein the front wheel includes a ratcheting front hub.

## 14

10. The two-wheel drive bicycle according to claim 1, wherein the head tube is cylindrical and has a diameter that measures between 1.5 and 2.5 inches.
11. The two-wheel drive bicycle according to claim 1, wherein the pair of meshing gears mesh at an angle of less than 90 degrees.
12. The two-wheel drive bicycle according to claim 1, wherein the steering mechanism includes a neck tube mounted at least partially within the head tube, the neck tube having a cutout, the rigid shaft extending into the cutout of the neck tube, and the cutout being sized such that the steering mechanism can pivot over a pivoting angle within the head tube with respect to the at least one rigid shaft.
13. The two-wheel drive bicycle according to claim 12, the pivoting angle is approximately 180 degrees.
14. A two-wheel drive bicycle comprising:  
a frame, the frame including a head tube;  
first and second wheels rotatably mounted to the frame;  
a power transfer mechanism including a drive chain coupled to the frame, the power transfer mechanism operable to transmit power from a rider of the bicycle to the first wheel; and  
a wheel drive mechanism including at least one rigid shaft operating to transmit power from the first wheel to the second wheel wherein the at least one rigid shaft extends within the frame from the first wheel to the head tube.
15. The two-wheel bicycle according to claim 14, wherein the wheel drive mechanism is configured to transmit power from the first wheel to the second wheel such that the second wheel is under-driven at a ratio of less than one revolution for each revolution of the first wheel.
16. The two-wheel bicycle according to claim 14, wherein the wheel drive mechanism is configured to transmit power from the first wheel to the second wheel such that the second wheel is over-driven at a ratio of greater than one revolution for each revolution of the first wheel.
17. A two-wheel drive bicycle, comprising:  
a frame, the frame including a head tube;  
first and second wheels rotatably mounted to the frame;  
a power transfer mechanism including a drive chain coupled to the frame, the power transfer mechanism operating to transmit power from a rider of the bicycle to the first wheel; and  
a wheel drive mechanism including an assembly of rigid shafts operating to transmit power from the first wheel to the second wheel, where the assembly of the rigid shafts extends at least partially through the head tube.

\* \* \* \* \*