



US006156058A

United States Patent [19]

[11] Patent Number: **6,156,058**

Kappel et al.

[45] Date of Patent: ***Dec. 5, 2000**

[54] **WARMING BLANKET FOR PEDIATRIC USE**

[75] Inventors: **Thomas F. Kappel**, St. Louis; **Dennis S. Chivetta**; **Scott D. Dikerhoff**, both of Ballwin; **Philip M. Metzler**, St. Charles, all of Mo.

[73] Assignee: **Mallinckrodt Inc.**, St. Louis, Mo.

[*] Notice: This patent is subject to a terminal disclaimer.

[21] Appl. No.: **09/399,186**

[22] Filed: **Sep. 20, 1999**

Related U.S. Application Data

[62] Division of application No. 08/674,578, Jul. 2, 1996, which is a continuation of application No. 08/187,561, May 27, 1997, Pat. No. 5,632,769.

[51] Int. Cl.⁷ **A61F 07/00**

[52] U.S. Cl. **607/107**; 62/259.003; 5/423

[58] Field of Search 607/104, 107; 62/259.3; 5/423

References Cited

U.S. PATENT DOCUMENTS

- 630,565 8/1899 Safran .
- 1,291,191 1/1919 Semple .
- 1,590,522 6/1926 Kalman .
- 1,777,982 10/1930 Popp .
- 2,093,834 9/1937 Gaugler .
- 2,110,022 3/1938 Kliesrath .
- 2,122,964 7/1938 Sweetland .
- 2,235,966 3/1941 Summers .
- 2,512,559 6/1950 Williams .
- 2,601,189 6/1952 Wales, Jr. .
- 2,617,915 11/1952 Blair .
- 2,700,165 1/1955 Talisman .
- 2,706,988 4/1955 Weber .
- 2,791,168 5/1957 Mauch .
- 2,834,033 5/1958 O'Brien .
- 2,998,817 9/1961 Armstrong .
- 3,034,132 5/1962 Landsberger et al. 607/104
- 3,307,554 3/1967 Thornton et al. .

- 3,308,850 3/1967 Gill .
- 3,610,251 10/1971 Sanderson .
- 3,674,034 7/1972 Hardy .
- 3,740,777 6/1973 Dee .
- 3,757,366 9/1973 Sacher .
- 3,844,339 10/1974 Kranz .
- 4,026,299 5/1977 Sauder .
- 4,094,357 6/1978 Sgroi .
- 4,398,535 8/1983 Guibert .
- 4,457,295 7/1984 Roehr .
- 4,572,188 2/1986 Augustine et al. .
- 4,653,131 3/1987 Diehl .
- 4,660,388 4/1987 Greene, Jr. .
- 4,777,802 10/1988 Feher .
- 4,807,644 2/1989 Sandhaus .
- 4,867,230 9/1989 Voss .
- 4,959,877 10/1990 Covil .

(List continued on next page.)

FOREIGN PATENT DOCUMENTS

- 1325484 12/1993 Canada .
- 0311336 4/1989 European Pat. Off. .
- 149244 11/1931 Switzerland .
- 85 03216 8/1985 WIPO .
- 94 03131 2/1994 WIPO .
- 95 20371 8/1995 WIPO .
- 95 35077 12/1995 WIPO .
- 96 03098 2/1996 WIPO .

Primary Examiner—Robert L. Nasser
Attorney, Agent, or Firm—Rothwell, Figg, Ernst & Manbeck, pc.

[57] ABSTRACT

The present invention relates to a blanket for use with forced air convection systems, wherein the blanket is sized to accommodate pediatric patients. The blankets according to the present invention may be used both over or under the patient, thereby facilitating use in the operating room or outside the operating room. The present invention also relates to a blanket for use with forced air convection systems which is nonflammable and laser resistant. In addition, the present invention relates to methods of prevention hypothermia and hyperthermia and to a method of making a blanket for use with forced air convection systems.

3 Claims, 5 Drawing Sheets

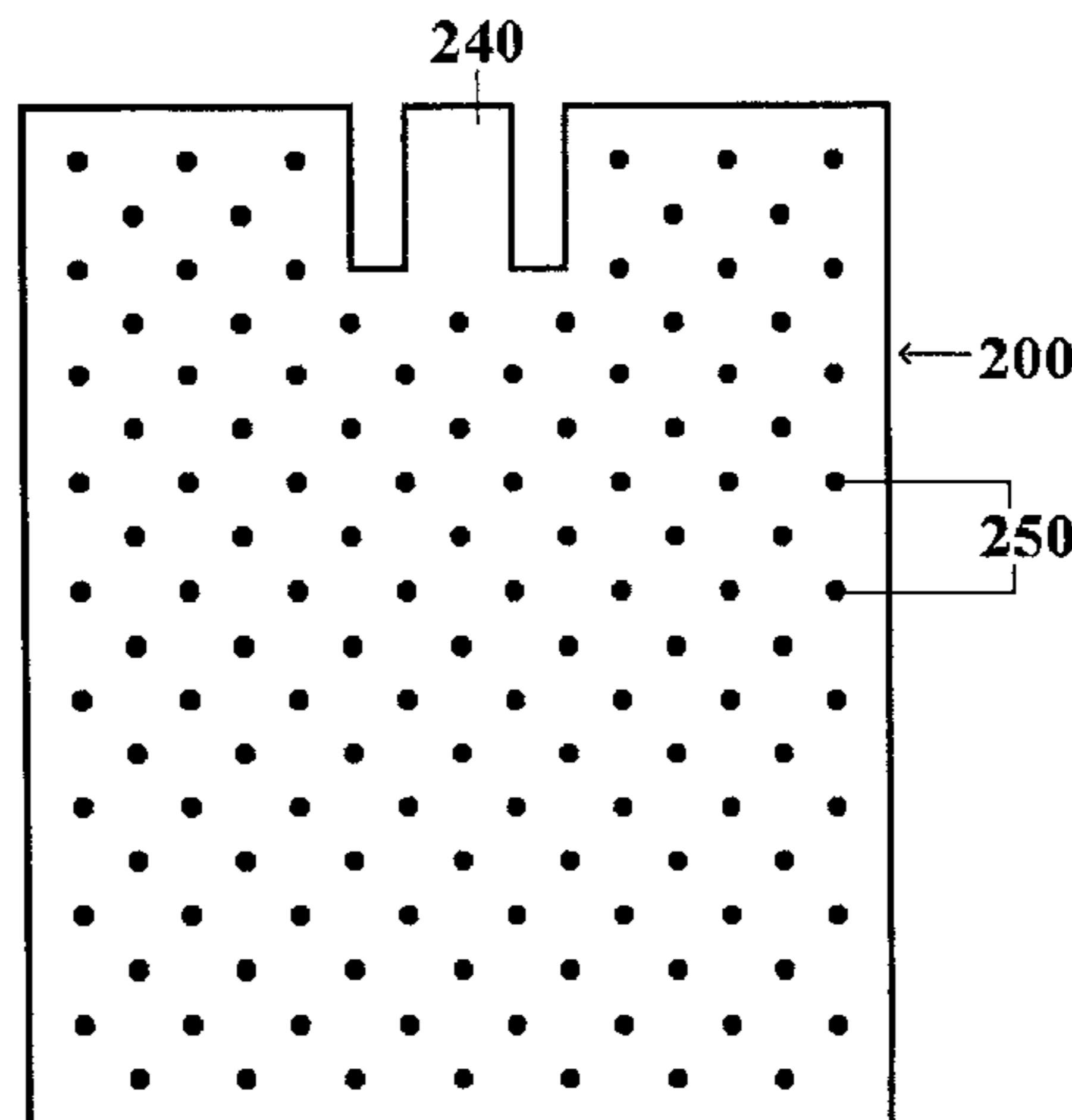

| U.S. PATENT DOCUMENTS | | | | | |
|-----------------------|---------|-------------------------|-----------|---------|--------------------------------|
| | | | 5,318,568 | 6/1994 | Kaufmann et al. . |
| 4,997,230 | 3/1991 | Spitalnick . | 5,324,320 | 6/1994 | Augustine et al. 607/107 |
| 5,022,110 | 6/1991 | Stroh . | 5,336,250 | 8/1994 | Augustine . |
| 5,044,364 | 9/1991 | Crowther . | 5,343,579 | 9/1994 | Dickerhoff et al. . |
| 5,097,548 | 3/1992 | Heck et al. . | 5,350,417 | 9/1994 | Augustine 607/104 |
| 5,106,373 | 4/1992 | Augustine et al. . | 5,360,439 | 11/1994 | Dickerhoff et al. . |
| 5,125,238 | 6/1992 | Ragan et al. 5/423 | 5,384,924 | 1/1995 | Dickerhoff et al. 607/104 |
| 5,165,400 | 11/1992 | Berke . | 5,392,847 | 2/1995 | Stephenson . |
| 5,184,612 | 2/1993 | Augustine . | 5,405,370 | 4/1995 | Irani . |
| 5,300,098 | 4/1994 | Philipot . | 5,405,371 | 4/1995 | Augustine et al. . |
| 5,300,100 | 4/1994 | Hickle et al. . | 5,408,712 | 4/1995 | Brun . |
| 5,300,102 | 4/1994 | Augustine et al. . | 5,443,488 | 8/1995 | Namenye et al. . |
| 5,304,217 | 4/1994 | Stephenson et al. . | 5,632,769 | 5/1997 | Kappel et al. 607/104 |

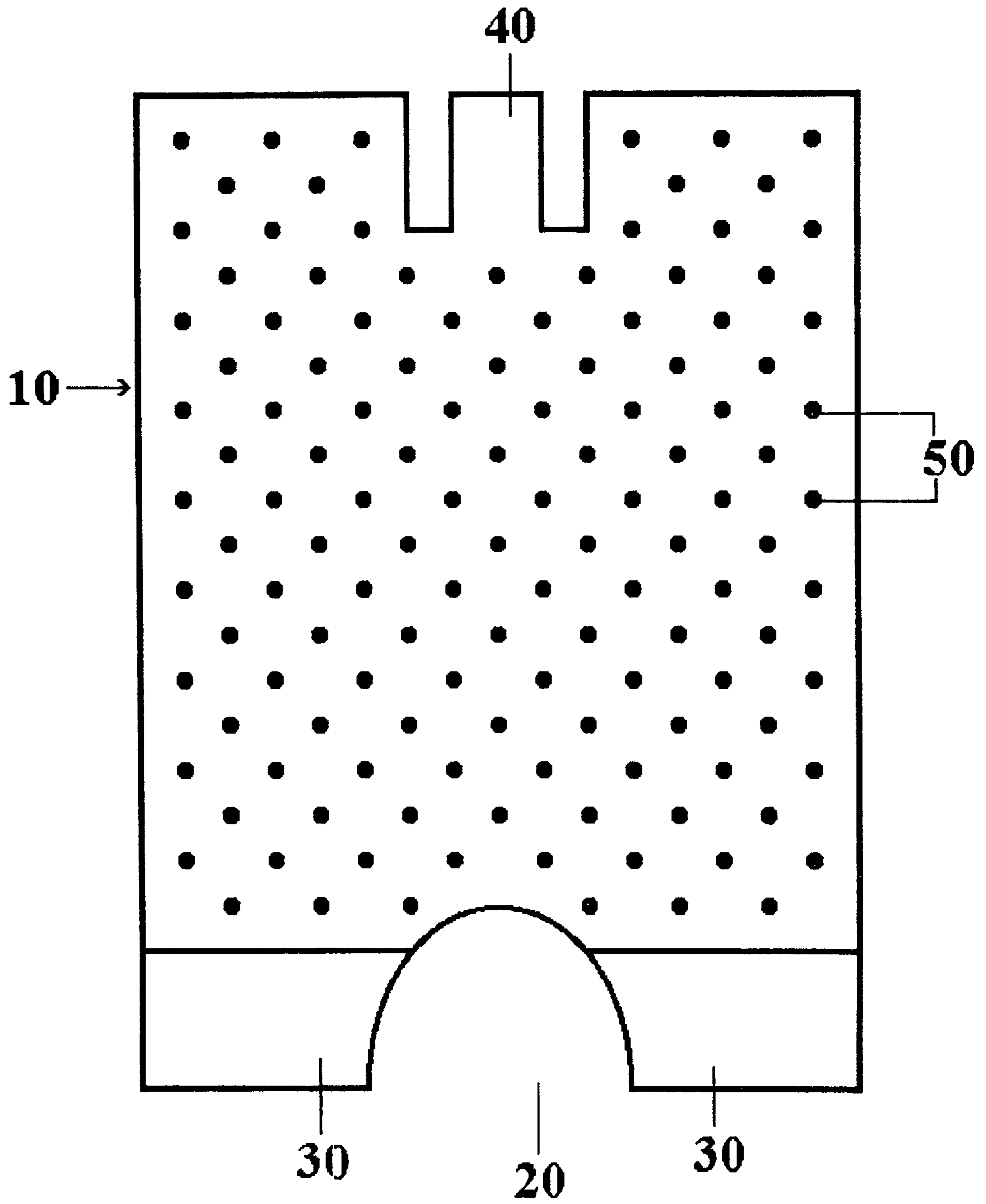

FIG. 1

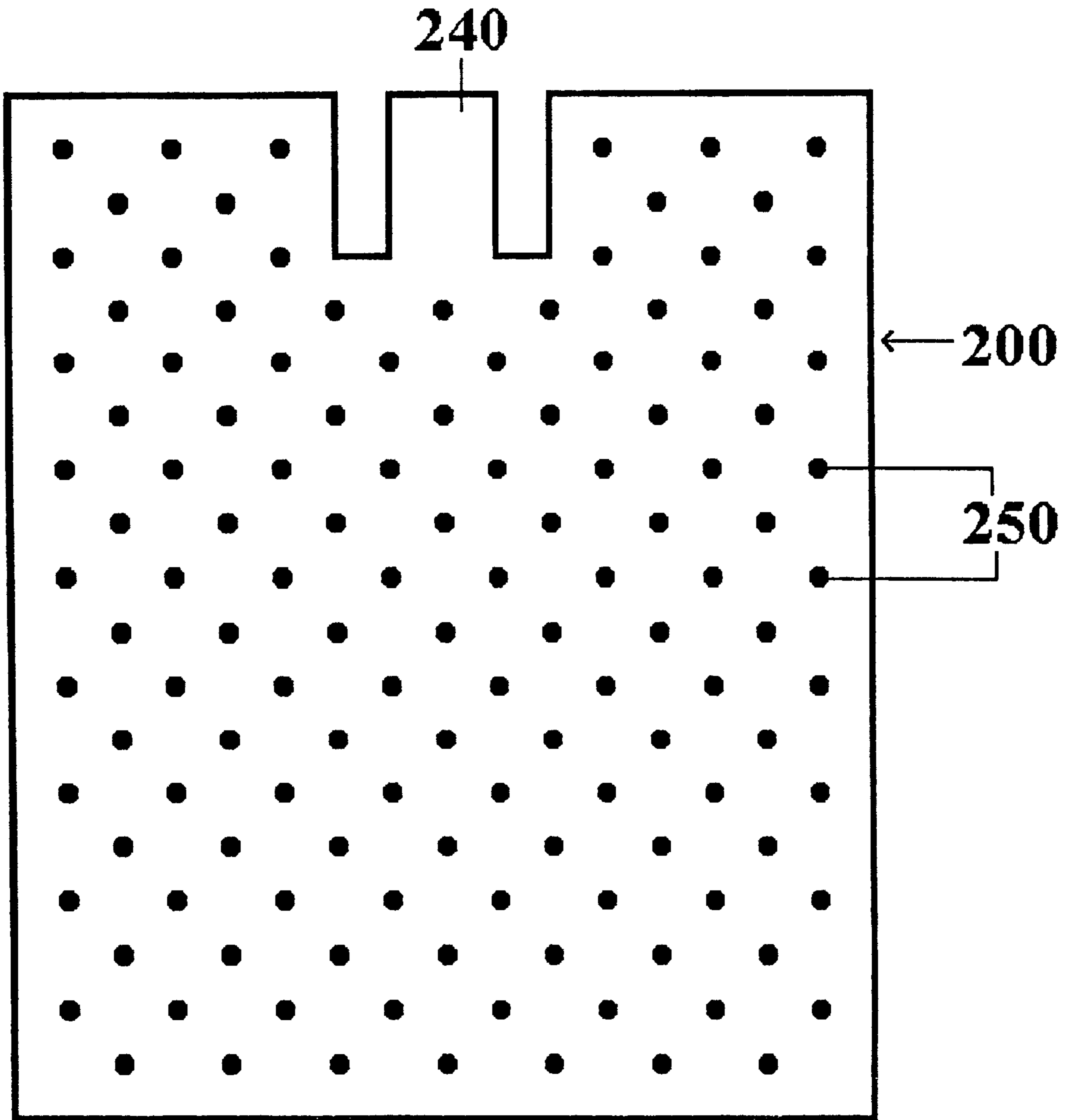

FIG. 2

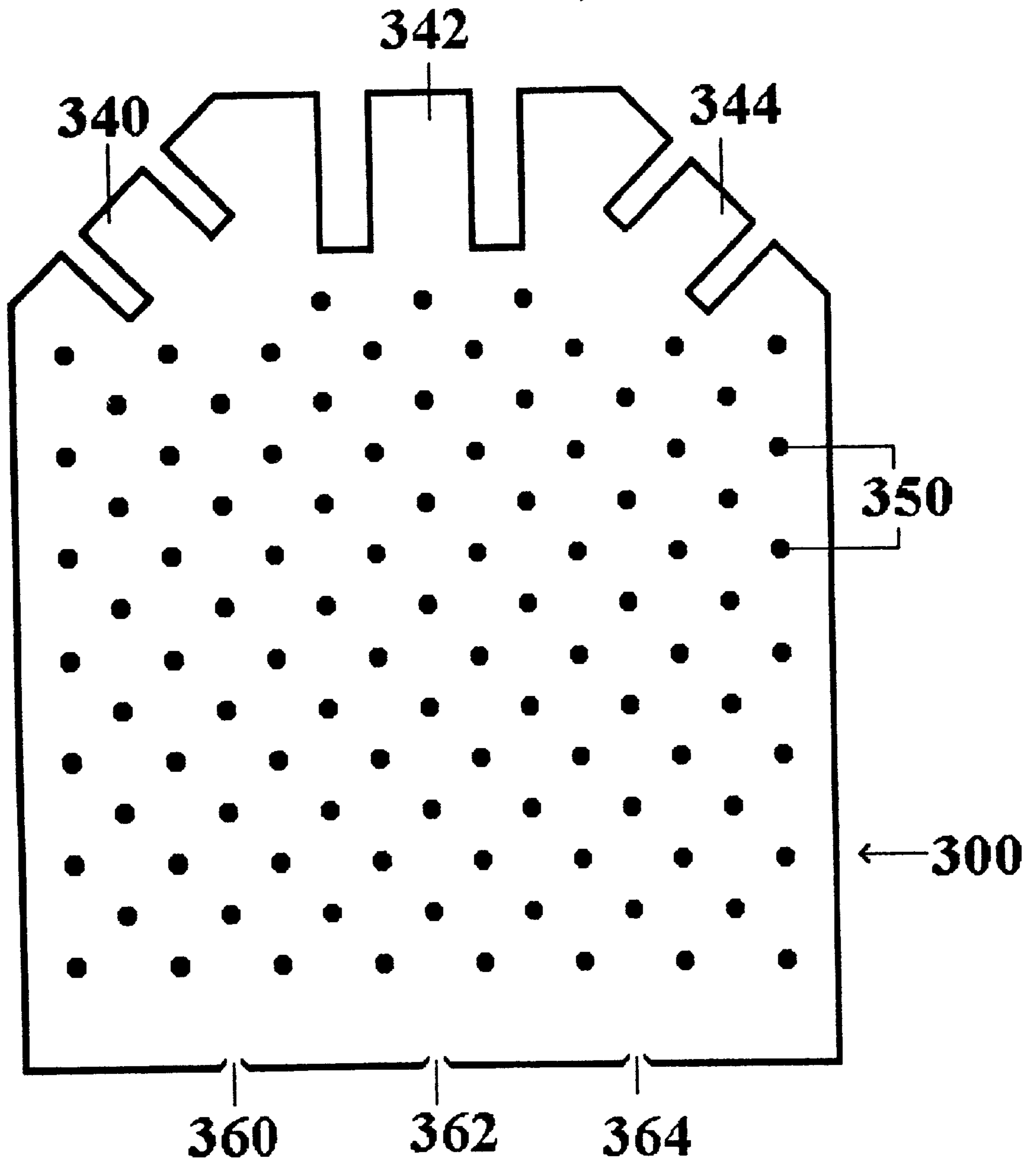

FIG. 3

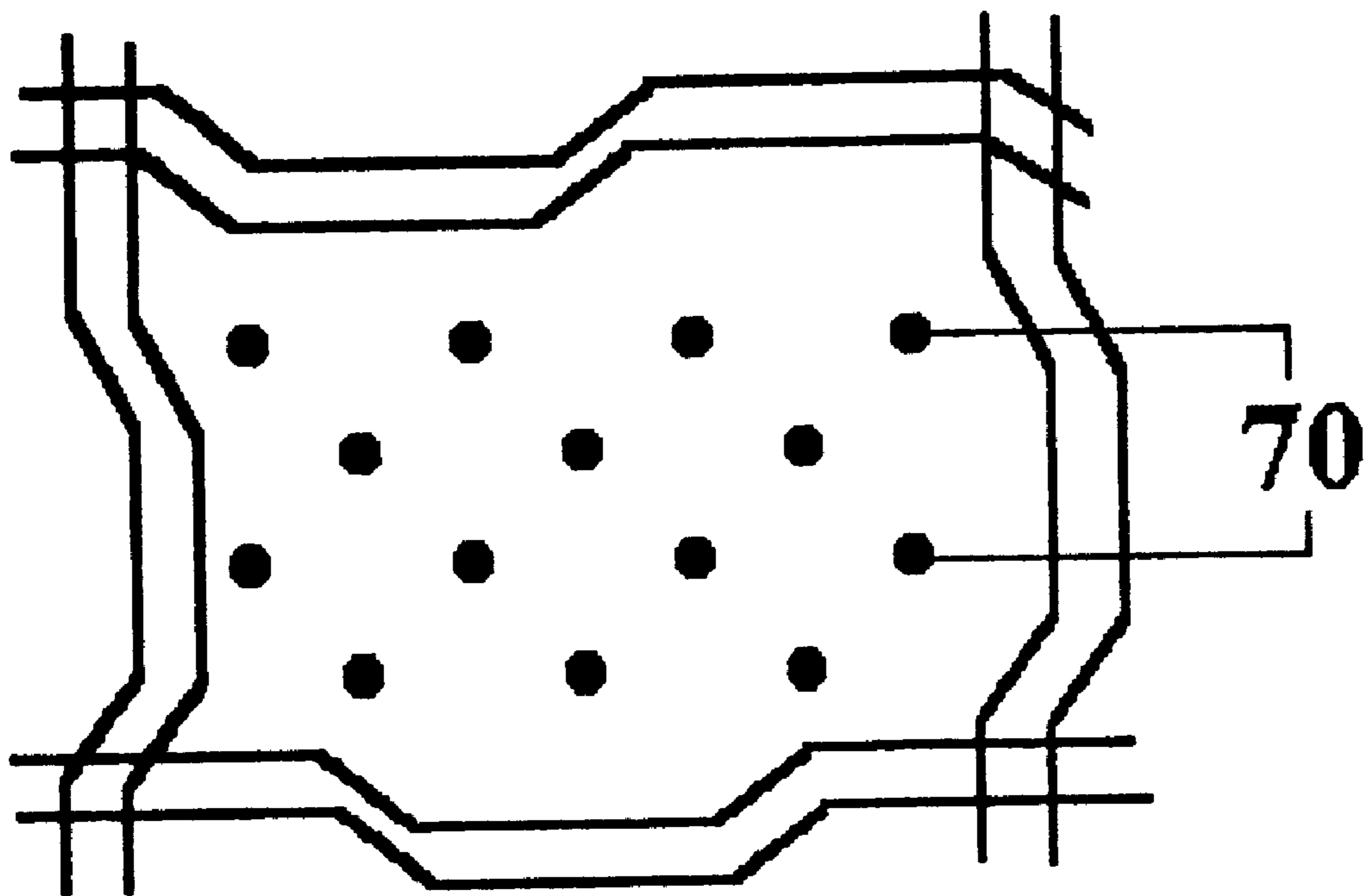

FIG. 4

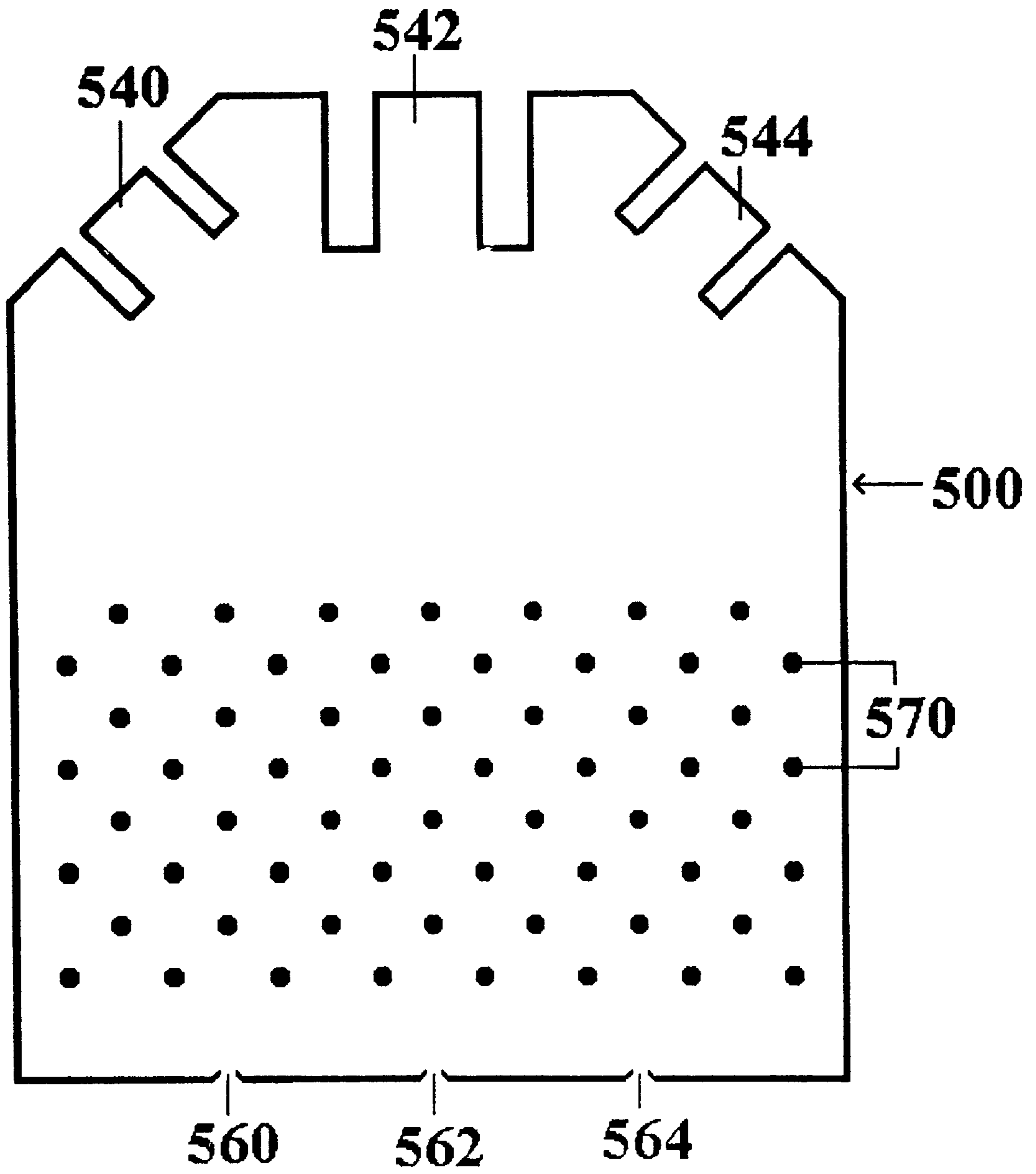

FIG. 5

WARMING BLANKET FOR PEDIATRIC USE

This application is a divisional application of U.S. patent application No. 08/674,578 filed Jul. 2, 1996 which is a continuation of U.S. patent application No. 08/187,561, now U.S. Pat. No. 5,632,769 patented on May 27, 1997.

BACKGROUND

Hypothermia is a condition of subnormal body temperature and presents serious consequences to the patient suffering therefrom. It has been shown that nearly seventy five percent of all patients who undergo surgical procedures develop hypothermia. This equates to approximately fourteen million patients a year in the United States alone. In the operating room, the hypothermic condition may be brought on by many factors including anesthesia, the air conditioning of the operating room, and the infusion of cold blood, I-V solutions, or irrigating fluids. Hypothermia is also a problem in the recovery room or PACU, as well as other areas in a hospital where room temperatures are kept cool and infusions of blood or other fluids may continue.

The prevention of hypothermia is especially important for pediatric care, because pediatric patients may be adversely effected by small changes in temperature. In particular, pediatric patients lose heat faster than adult patients because of their relatively low skin surface area to body mass ratio. Conversely, pediatric patients can also gain heat faster than adult patients. Therefore, pediatric patients are more susceptible to surgical complications, such as catching colds, from slight changes in temperature.

Several methods and products have been developed to help prevent hypothermia from occurring; such as the use of infrared lamps, cotton blankets, and warm water mattresses. However, none of these methods and products have proven completely successful. In fact, it has been shown that these methods and products can not even prevent the patients from losing their endogenous heat. (See *Journal of Post Anesthesia Nursing*, Vol. 5, No. 4, August 1990, pp 254-263).

Another method of helping to prevent hypothermia that has proven very effective is the use of forced warm air convection. As early as 1937, a refrigeration blanket using cold air convection was suggested in U.S. Pat. No. 2,093,834 to Gaugler. This blanket included a plurality of layers for channeling air flow from an inlet port. Non-inflatable portions were provided around the periphery of the blanket to secure the blanket around the body. Gaugler does not mention hypothermia treatment and does not suggest that the blanket could be used to supply warm air.

U.S. Pat. No. 2,512,559 to Williams also relates to a blanket for providing cooled air to a person. The blanket in Williams comprised a plurality of thin sheets of material connected together at a plurality of discrete locations and connected together in a continuous line about the peripheral edge. An air inlet was provided to communicate with space between the sheets to allow cool air to be supplied thereto. Again, no mention of hypothermia treatment or the supply of warm air is made.

In U.S. Pat. No. 4,572,188 to Augustine et al, a forced air convection system which can supply either cool or warm air to a blanket is described. The blanket in Augustine et al comprises a plurality of inflatable hollow tubes having their interiors connected together through transverse openings. An entry port is provided in the upper surface of the blanket for admitting the cool or warm air and small exit ports are provided through the lower surface to allow the cool or warm air to flow out toward a body covered by the blanket.

Other patents relating to the supply of cool or warm air to a person through an inflatable blanket include U.S. Pat. Nos. 4,660,388 to Greene, Jr.; 4,777,802 to Feher; and 4,867,230 to Voss. Each of these patents describe blankets having various attributes and configurations to supply cool or warm air to the person.

While some of the above systems suggest use in the operating room, they all possess similar disadvantages for such use. In particular, for the system to work in the operating room, the blanket must be attached to an air supply or blower unit through a hose. The placement of the hose during surgery can be crucial, as full access to the patient can be compromised if the hose must be located in a position which the surgeon, anesthesiologist or other surgical team member wants to occupy. In addition, the placement of the hose can create difficulties in locating other equipment such as I-V stands, monitors, etc. necessary for the surgical procedure. Moreover, it is important that the hose be as short as possible, because longer hoses lose more heat before delivery to the blanket, and thus overall effectiveness of the blanket is reduced.

Hose placement is not as critical in a non-operating room setting such as the PACU, ICU, or standard hospital room, but it is still desirable to have options for hose placement. This is especially true regarding the interspatial relationships between the blower unit and other equipment such as I-V stands, etc.

The prevention of hypothermia in pediatric patients requires special features and specifications. For purposes of this application, the term "pediatric" will be used to describe a number of patients, including neonates, infants, and children. In particular, the size of pediatric patients require that a relatively small blanket be provided which will still provide all of the warming advantages of a larger adult-sized blanket. Further, in certain surgical procedures, it is desirable to have the pediatric patient lie on top of the blanket because then the blanket is not in the way of the surgeon or other surgical team member. This requires the blanket to have sufficient air flow through the blanket to provide the warming therapy needed to prevent hypothermia.

None of the prior art noted above mentions use of blankets for pediatric patient care. Therefore, there remains a need in the art for improvements to forced warm air convection systems, especially for blankets which can be used in the treatment of pediatric patients.

OBJECTS OF THE INVENTION

It is one object of the present invention to provide a blanket for a forced warm air convection system that may be used specifically for pediatric patients.

It is another object of the present invention to provide a blanket for a forced warm air convection system that may be used over or under a pediatric patient.

It is a further object of the present invention to provide a blanket for a forced warm air convection system that allows placement of a blower and an air supply hose to be selectively chosen depending on the needs of the surgical procedure to be performed.

It is also an object of the present invention to provide a blanket for a forced warm air convection system that is nonflammable and laser resistant.

SUMMARY OF THE INVENTION

The above objects and others are accomplished according to the present invention by providing a blanket for a warm

air convection system having a size suitable for a pediatric patient and which includes means to provide enough air flow to accomplish the desired warming therapy.

BRIEF DESCRIPTION OF THE DRAWINGS

FIG. 1 is a plan view of a blanket for a forced warm air convection system for use primarily in non-operating room settings according to one embodiment of the present invention.

FIG. 2 is a plan view of a blanket for a forced warm air convection system for use primarily in the operating room according to another embodiment of the present invention.

FIG. 3 is a plan view of a blanket for a forced warm air convection system for use primarily in the operating room according to a further embodiment of the present invention.

FIG. 4 is a plan view of a portion of a blanket for a forced warm air convection system showing the perforation pattern according to an embodiment of the present invention.

FIG. 5 is a plan view of a blanket for a forced warm air convection system for use primarily in the operating room showing the sheet having perforations according to an embodiment of the present invention.

DETAILED DESCRIPTION OF THE INVENTION

The present invention relates primarily to the prevention of hypothermia in pediatric patients. In particular, the present invention relates to warm air convection blankets for providing warm air to pediatric patients undergoing surgical or other medical procedures. The blankets according to the present invention are designed to be used primarily for pediatric patients from newborn to about five years of age and weights from about five to about fifty pounds.

In addition, the blankets according to the present invention are designed in such a manner that a particular blanket could be used to warm either the upper body, including the head, of a patient, the lower body of the patient, or the entire body of the patient. It is desirable that temperature distribution across the blanket not vary by more than about 5° C. This is accomplished in the blankets according to the present invention, because the blankets can be used for relatively high air temperature distribution at relatively high airflow.

FIG. 1 is a plan view of a blanket, generally designated by reference numeral 10, for a forced warm air convection system, wherein the blanket 10, is appropriate for use primarily outside the operating room. The blanket 10, has a generally rectangular shape and include a head recess portion 20, and shoulder extensions 30. The blanket 10, comprises two sheets of material which are sealed together along their peripheral edges and are connected together at connection spot welds 50, discretely located on the interior surface portions of the sheets. By connecting the sheets of the blanket 10, in this manner, the blanket 10, may be inflated by supplying air to an air chamber formed between the sheets of material.

The blanket 10, further includes an inlet port 40, which communicates with the air chamber of the blanket 10, and may be used to supply air to the air chamber of the blanket 10, so as to inflate blanket 10. One sheet of the blanket 10, is provided with a plurality of small exit perforations 70, (FIG. 4) to allow warm air to escape from the blanket 10, toward a patient.

In use, the blanket 10, is placed over the body of a patient so that the patient's head remains exposed within the head recess portion 20, and the inlet port 40, is located at the feet

of the patient. The blanket 10, should be placed such that the sheet having perforations 70, faces the patient. The shoulder extensions 30, are draped over the shoulders of the patient and then tucked under the patients' shoulders to secure the blanket 10, in place. Once the blanket 10, is in place, the blanket 10, may be inflated with warm air through inlet port 40. The warm air is constantly supplied to the air chamber of blanket 10, through inlet port 40, and exits the blanket 10, through the perforations 70, to provide warming therapy to the patient.

The inlet port 40, may initially be closed by any suitable means such as sealing, folding, taping, snapping, etc. In the case where the inlet has been permanently sealed, means such as a perforated tear strip or punch out panel may be provided to enable easy opening of the inlet port selected for use. As an alternative, the inlet may simply be cut open with scissors or a knife.

Alternatively, the inlet port 40, may be initially closed by means that allow for reversibly opening and re-closing. In particular, means such as an adhesive strip or label, double-sided tape, snaps, zippers, folding flaps, folding wire or plastic bars, a ziplock type seal, or hook and loop type fastener, etc. may be utilized. In the alternative, a rubber, elastic, or plastic band could be used to tighten the material of the inlet port 40, around a nozzle inserted therein for supplying air to the interior of the blanket 10.

The perforations 70, formed through one sheet of the blanket 10, are formed by a punching procedure which forms clean, even holes. This method provides a blanket having consistent air flow characteristics. In contrast, perforations of prior art blankets are normally ripped or cut through the lower surface of the blanket which leaves ragged, uneven holes and contributes to widely varying air flow patterns.

As shown in FIG. 4, perforations 70, are formed in off-set rows. The perforations 70, in a given row extend across the entire width of the blanket, and multiple rows of perforations 70, extend across the entire length of the blanket. Adjacent rows of perforations are offset in such a manner that a perforation in any given row occurs midway between adjacent perforations in an adjacent row of perforations. Preferably, the distance between adjacent rows of perforations 70, is about 1 and 1/8 inches and the distance between adjacent perforations 70, in the same row is about 1 and 1/4 inches.

While the blanket 10, has been described as being for use primarily outside the operating room, it should be noted that the blanket 10, may also be appropriate for use in the operating room.

FIG. 2 is a plan view of a blanket, generally designated by reference numeral 200, for a forced warm air convection system, wherein the blanket 200, is appropriate for use primarily in the operating room. The blanket 200, is very similar to the blanket 10, described above, having a generally rectangular shape but does not include a head recess portion or shoulder extensions. The blanket 200, comprises two sheets of material which are sealed together along their peripheral edges and are connected together at connection spot welds 250, discretely located on the interior surface portions of the sheets. By connecting the sheets of the blanket 200, in this manner, the blanket 200, may be inflated by supplying air to an air chamber formed between the sheets of material.

The blanket 200, further includes an inlet port 240, which communicates with the air chamber of the blanket 200, and may be used to supply air to the air chamber of the blanket

200, so as to inflate blanket **200**. One sheet of the blanket **200**, is provided with a plurality of small exit perforations **70**, (FIG. 4) to allow warm air to escape from the blanket **200**, toward a patient.

In use, the blanket **200**, is placed over or under the body of a patient. When placed over the patient, the blanket **200**, is placed so that the sheet having perforations **70**, faces the patient and so that the area of the patient upon which surgery or other procedures will be performed remains exposed. The blanket **200**, may be situated such that inlet port **240**, is located at the feet or at the head of the patient. Once the blanket **200**, is in place, the blanket **200**, may be inflated with warm air through inlet port **240**. The warm air is constantly supplied to the air chamber of blanket **200**, through inlet port **240**, and exits the blanket **200**, through the perforations **70**, to provide warming therapy to the patient.

The inlet port **240**, may initially be closed using any of the means noted above with respect to inlet port **40**, of blanket **10**. The perforations **70**, formed through one sheet of the blanket **200**, are formed by the same punching procedure described above with respect to blanket **10**.

While the blanket **200**, has been described as being for use primarily in the operating room, it should be noted that the blanket **200**, may also be appropriate for use outside the operating room.

When placing blankets under patients, it is often the case that the weight of the patient will cause air flow to be partially or completely restricted through certain portions of the blanket. Therefore, it is desirable to include means of providing for greater and more consistent air flow through the blanket in order to supply the same amount of warming therapy to the patient.

FIG. 3 is a plan view of a blanket, generally designated by reference numeral **300**, for a forced warm air convection system, wherein the blanket **300**, is appropriate for use primarily in the operating room. The blanket **300**, is very similar to the blanket **10**, described above, having a generally rectangular shape and comprising two sheets of material which are sealed together along their peripheral edges and are connected together at connection spot welds **350**, discretely located on the interior surface portions of the sheets. By connecting the sheets of the blanket **300**, in this manner, the blanket **300**, may be inflated by supplying air to an air chamber formed between the sheets of material.

The blanket **300**, further includes three separate inlet ports **340**, **342**, and **344**, which communicate with the air chamber of the blanket **300**, and may be used to supply air to the air chamber of the blanket **300**, so as to inflate blanket **300**. One sheet of the blanket **300**, is provided with a plurality of small exit perforations **70**, (FIG. 4), to allow warm air to escape from the blanket **300**, toward a patient. In addition, blanket **300**, includes three exit vents **360**, **362**, and **364**, which communicate with the air chamber of the blanket **300**, and which allow warm air to escape from the blanket **300**.

In use, the blanket **300**, may be placed over or under the body of a patient, but is preferably placed under the patient. When placed under the patient, the blanket **300**, is placed so that the sheet having perforation **70**, is facing the patient. The blanket **300**, may be situated such that inlet ports **340**, **342**, and **344** are located at the feet or at the head of the patient. Once the blanket **300**, is in place, the blanket **300**, may be inflated with warm air through any one of inlet ports **340**, **342**, or **344**, or may be inflated through more than one inlet port if so desired. The warm air is constantly supplied to the air chamber of blanket **300**, through the selected inlet port and exits the blanket **300**, through the perforations **70**,

to provide warming therapy to the patient and also through the vents **360**, **362**, and **364**, to increase air flow through the blanket **300**. By providing multiple inlet ports and exit vents, the circulating warm air has more pathways to move through the blanket and thus provide a greater and more consistent airflow through the blanket. Therefore, more consistent warming therapy can be provided to the patient, even in the event that air flow is partially or completely restricted through certain portions of the blanket **300**.

The inlet ports **340**, **342**, and **344**, may initially be closed using any of the means noted above with respect to inlet port **40**, of blanket **10**. The perforations formed through the one sheet of the blanket **300**, are formed by the same punching procedure described above with respect to blanket **10**.

While the blanket **300**, has been described as being for use primarily in the operating room, it should be noted that the blanket **300**, may also be appropriate for use outside the operating room.

FIG. 5 is a plan view of a blanket, generally designated by reference numeral **500**, for a forced air convection system, wherein the blanket **500**, is appropriate for use primarily in the operating room. In particular, FIG. 5 shows a preferred embodiment of the present invention, wherein perforations **570**, are formed over only a portion of one sheet of the blanket **500**. Perforations **570**, may be formed by the same punching procedure described above with respect to blanket **10**.

Perforations **570**, are formed in off-set rows, such that the perforations **570**, in a given row extend across the entire width of the blanket **500**, and multiple rows of perforations **570**, extend across about half the length of the blanket, beginning at the end of the blanket **500**, having exit vents **560**, **562**, and **564**. Adjacent rows of perforations are offset in such a manner that a perforation in any given row occurs midway between adjacent perforations in an adjacent row of perforations. Preferably, the distance between adjacent rows of perforations **570**, is about 1 and $\frac{1}{8}$ inches and the distance between adjacent perforations **570**, in the same row is about 1 and $\frac{1}{4}$ inches.

The preferred embodiment shown in FIG. 5 provides several advantages associated with providing a warming blanket under a patient. In particular, as noted above, the provision of multiple inlet ports and exit vents, allows the circulating warm air to move through more pathways within the air chamber of the blanket and thus provide a greater and more consistent airflow through the blanket.

In addition, when a warming blanket is provided under a patient, the air exits from the perforations upward and toward the surgical field. It is particularly undesirable to have air exit from perforations in the vicinity of the area of the patient's body upon which a surgical procedure is being carried out. Such exiting air can cause distractions to the surgeon or other surgical team member, and may increase the risk of contamination of the surgical site.

This disadvantage is overcome by providing a blanket as shown in FIG. 5, wherein the perforations **570**, are provided along only half of the length of the blanket **500**. In particular, the blanket **500**, may be positioned under the patient in such a manner that the perforation **570**, are under areas of the patient's body that are not in the area of the surgical site. It should be noted that the blanket **500**, can be positioned such that inlet ports **540**, **542**, and **544** are at the feet or at the head of the patient, thereby allowing the perforations **570**, selectively positioned under the desired portion of the patient's body.

When using the blanket **500**, warming therapy is provided in two ways to the patient. In the area where perforations

570, exist, warming is done primarily by convective means, i.e. by the escape of warm air through perforations 570, toward the patient. In the areas where there are no perforations, the patient is warmed primarily by conductive and radiant transfer of warmth through the blanket 500, material to the patient.

In a more preferred embodiment, a sheet (not shown) may be placed over the patient to trap the warm air being expelled from the perforations 570. The sheet may be of any appropriate material, but preferably is made of disposable plastic. In this way, warm air that would normally provide no heating to the patient, such as the air escaping from perforation 570, which are distant from any portion of the patient's body, can aid in the heat transfer to the patient. Also, the sheet may include an adhesive such as surgical tape along at least one side for attachment to the blanket 500, or the patient as may be appropriate, in such a manner as to restrict air flow to the surgical site. Therefore, the risk of contamination to the surgical site can be further reduced. In a most preferred embodiment, the sheet is a clear plastic cover which provides all of the advantages above, and in addition allows access and visibility to areas of the patient that are covered.

Several features of the present invention are generic in nature, but may have been described and shown in only one of the drawings. Therefore, the following provides further description of such generic features.

The blankets according to the present invention should be of a size which accommodates pediatric patients comfortably, but without too much excess which could get in the way during hospital procedures. In particular, if the blanket is to be used over the patient, the uninflated blanket should be from about 24 inches to about 36 inches wide and from about 50 inches to about 64 inches long. Preferably, an uninflated blanket for use over the patient is about 30 inches wide and about 57 inches long. Once inflated, the blanket will have somewhat smaller dimensions as the inflation will act to contract the sides and ends of the blanket. In particular, in the preferred embodiment, the inflated blanket for use over the patient will be about 26 inches wide and about 50 inches long.

For blankets which will be used over the patient, the use of shoulder extensions may be included to help to secure the blanket during use. The shoulder extensions as described above should be sealed off from the air chamber of the blanket so that the shoulder extensions are non-inflatable. The shoulder extensions extend may extend from either end of the blanket, but preferably extend from the end of the blanket opposite from the inlet port or ports. Preferably, the shoulder extensions are about 10 inches wide and about 7 inches long.

For blankets which will be used under the patient, the uninflated blanket should be from about 20 inches to about 30 inches wide and from about 35 inches to about 47 inches long. In a preferred embodiment, an uninflated blanket for use under the patient is about 25 inches wide and about 41 inches long. In the preferred embodiment, the inflated blanket for use under the patient will be about 22 inches wide and about 35 inches long.

Some blankets described above have been shown with a single inlet port and some with multiple, i.e. three inlet ports. By providing a blanket with multiple inlets, the user has the choice of positioning the air supply or blower unit and the supply hose at various locations depending upon the need to access the surgical site. In particular, the inlet used may be optimally chosen to cause the least amount of interference

with access to the surgical site. In addition, by providing resealable inlet ports, the user may actually switch inlets during use which may be particularly advantageous in allowing the surgeon full access to the patient during the surgical procedure.

Further, while the present invention has been particularly described by reference to a blanket having one or three inlets, it will be evident to one skilled in the art that any number of inlets could be provided to enable even greater flexibility of use. The placement of additional inlets is limited only by the need to maintain good air distribution and flow within the blanket.

Moreover, it is possible to connect a supply source of warm air to more than one inlet at the same time when using the blanket according to the present invention. This can be accomplished by either connecting different supply sources to different inlets, or alternatively, by connecting a single supply source to multiple inlets using a multiply branched supply hose. For example, if there are two inlets, the supply hose could have a y-shaped configuration. Each of these embodiments of using the present invention, may be advantageous in providing more even heat distribution to all parts of the blanket.

The blankets according to the present invention are all constructed using welds, such as the spot welds noted above to connect the separate sheets of the blanket. The provision of welds provides several advantages, especially for use on pediatric patients. In particular, the welds provide a relatively open air chamber and allows the free flow of warm air in all directions within the blanket. This free air flow provides better heat distribution within the blanket and allow the blankets of the present invention to accomplish the goal of having heat distribution across the blanket vary by less than about 5° C. This is very important in reducing the occurrence of hot or cold spots within the blanket during use. Further, the welds provide additional stability when the blanket is used under the patient. In fact, it has been found that the welds help to prevent the pediatric patient from shifting when placed on top of the blanket and may also eliminate the need for using further materials under the patient for support and cushioning.

In general, for blankets which will be used over the patient, the spot welds noted above may be provided in off set rows across the entire width and along the entire length of the blanket. Adjacent rows of spot welds are offset in such a manner that a spot weld in any given row occurs midway between adjacent spot welds in an adjacent row of spot welds. Preferably, for blankets which will be used over the patient, the distance between adjacent rows of spot welds is about 3 inches and the distance between adjacent spot welds in the same row is about 3 inches.

For blankets which will be used under the patient, spot welds may also be provided in off set rows across the entire width and along the entire length of the blanket. Adjacent rows of spot welds are offset in such a manner that a spot weld in any given row occurs midway between adjacent spot welds in an adjacent row of spot welds. However, for blankets for use under a patient the spacing of the spot welds should be provided in a somewhat tighter pattern. The closer spacing of the spot welds increases the stability of the blanket and reduces shifting of the patient on the blanket as noted above. Preferably, for blankets which will be used under the patient, the distance between adjacent rows of spot welds is about 2 and ½ inches and the distance between adjacent spot welds in the same row is about 2 and ½ inches.

In one embodiment according to the present invention, certain spot welds may be eliminated. By leaving out certain

spot welds, the distribution of air may be directed more thoroughly within the blanket and temperature distribution may be made more uniform and consistent. This can be very advantageous in reducing the occurrence of hot or cold spots within the blanket during use.

The blankets according to the present invention may be formed of any suitable material capable of being sealed together at selected positions and having sufficient strength to allow inflation and adequate air distribution within the inflated air chamber. Such materials include plastics, natural fibers and synthetic blends; such as cotton, wool, silk, rayon, polypropylene, cotton and polyester blends, polyester and cellulose blends, rayon and polyester blends, non-woven wood pulp compositions, laminated plastic and wood pulp materials, and combinations thereof.

In addition, it should be noted that the blankets may be formed of various laminated layers of the above materials. For example, each sheet of the the blankets according to the present invention, could be a two or three ply layer of material.

In another embodiment of the present invention, the convective air warming blankets may be treated with a fire retardant material. In particular, the blankets may be treated by a spraying, coating, or other appropriate technique, with the fire retardant material. Such treatment produces advantageous blankets which are both nonflammable and laser resistant. The fire retardant spray may be any suitable spray which will render the blanket nonflammable and laser resistant. Such a spray may be used regardless of the material from which the blanket is made. One material which has been found to be useful as a fire retardant spray for convective air warming blankets is available from Project Fire Safety, Inc. and is identified as product number MG 702. The treatment of blankets to render them nonflammable and laser resistant is applicable to pediatric and adult sized blankets, as well as any other size that may be desired.

It should be noted that while particular blankets described above have been identified for use primarily in the operating room or for use primarily outside the operating room, that it will be evident to one skilled in the art that any of the blankets according to the present invention could be used in areas other than the primarily indicated area. For example, a blanket for use primarily in the operating room, could also be used outside the operating room, such as in the PACU, ICU or regular hospital room, and vice versa. Further, any of the blankets described herein could also be used in a nursing home, patient's home or any place where hypothermia is a problem.

The blankets according to the present invention have been described as being useful in the prevention and treatment of hypothermia. It will be evident to one skilled in the art that

a source of pressurized cooled air or room temperature air could also be provided to the blankets according to the present invention to control body temperature of the patient under conditions of hyperthermia.

The foregoing has been a description of certain preferred embodiments of the present invention, but is not intended to limit the invention in any way. Rather, many modifications, variations and changes in details may be made within the scope of the present invention.

What is claimed is:

1. An inflatable pediatric blanket for a forced air convection system comprising:

an upper sheet of material having a generally rectangular shape with a peripheral edge, an upper end, a lower end and two sides; a lower sheet of material having a generally rectangular shape with a peripheral edge, an upper end, a lower end and two sides; wherein said upper sheet and said lower sheet are sealed together around their peripheral edges at their respective upper ends, lower ends and sides, to provide an inflatable blanket with an air chamber having an upper end, a lower end, and two sides therebetween;

three inlet ports positioned at one end of said blanket and connected to said inflatable air chamber through which inflation medium may be introduced to said inflatable air chamber through one or more of said inflation ports to inflate said blanket, wherein a first inlet port is positioned at one corner of said one end of said blanket, a second inlet port is positioned substantially centrally at said one end of said blanket, and a third inlet port is positioned at a second corner of said one end of said blanket, wherein said blanket is further sealed together at multiple welds distributed across interior surface regions of said upper sheet and said lower sheet to form said inflatable air chamber therebetween, wherein said blanket further includes at least one exit vent communicating with said air chamber through an opposite end of said blanket from an end where said inlet ports are located.

2. A blanket according to claim 1, wherein said blanket includes only one exit vent, which is positioned in about a center of said opposite end of said blanket.

3. A blanket according to claim 1, wherein said blanket includes three exit vents positioned along said opposite end of said blanket, wherein a first exit vent is positioned at about one corner of said opposite end of said blanket, a second exit vent is positioned at about a center of said opposite end of said blanket, and a third exit vent is positioned at about the other corner of said opposite end of said blanket.

* * * * *

UNITED STATES PATENT AND TRADEMARK OFFICE
CERTIFICATE OF CORRECTION

PATENT NO :
DATED : 6,156,058
December 5, 2000
INVENTOR(S) : Kappel, et al.

It is certified that error appears in the above-identified patent and that said Letters Patent is hereby corrected as shown below:

The name of inventor Scott D. Dikerhoff is misspelled. Please correct to Scott D. Dickerhoff.

Signed and Sealed this
Twenty-second Day of May, 2001

Attest:



NICHOLAS P. GODICI

Attesting Officer

Acting Director of the United States Patent and Trademark Office