



US006152956A

United States Patent [19] Pierce

[11] Patent Number: **6,152,956**

[45] Date of Patent: **Nov. 28, 2000**

[54] **PROSTHESIS FOR ENDOVASCULAR REPAIR OF ABDOMINAL AORTIC ANEURYSMS**

5,769,887 6/1998 Brown et al. 623/1

FOREIGN PATENT DOCUMENTS

1457-921 2/1989 U.S.S.R. .

OTHER PUBLICATIONS

Blum, U. et al., "Abdominal aortic aneurysms: preliminary technical and clinical results . . .", *Radiology* 198(1):25-31 (Jan. 1996).

Blum, U. et al., "Endoluminal stent-grafts for infrarenal abdominal aortic aneurysms", (Name of publication unknown), 336(1):13-20 (Jan. 2, 1997).

Chuter, T. et al., "Transfemoral endovascular aortic graft placement", *Journal of Vascular Surgery* 18(2):185-197 (Aug. 1993).

Cragg, A. et al., "Nitinol intravascular stent: Results of preclinical evaluation", *Radiology* 189(3):775-778 (Dec. 1993).

Moore, W. et al., "Transfemoral endovascular repair of abdominal aortic aneurysm: Results of the North American EVT phase 1 trial", *Journal of Vascular Surgery* 23(4):543-553 (Apr. 1996).

Palmaz, J. et al., "Use of stents covered with polytetrafluoroethylene in experimental abdominal aortic aneurysm", *Journal of Vascular and Interventional Radiology* 6(6):879-885 (Nov.-Dec. 1995).

(List continued on next page.)

Primary Examiner—Vincent Miller
Assistant Examiner—Choon P. Koh
Attorney, Agent, or Firm—Merchant & Gould P.C.

[57] ABSTRACT

An apparatus for endovascular repair of aortic aneurysms is disclosed. In one form, the apparatus includes a tube and an anchoring unit that includes a plurality of thin lines. The tube serves as a conduit for blood flow in an aneurysm of an aorta. First end of the lines are connected to a first end of the tube. Second end of the lines are separated by a distance from the first end of the tube for anchoring the apparatus at a location away from the aneurysm.

19 Claims, 10 Drawing Sheets

[76] Inventor: **George E. Pierce**, 270 Lakeshore West, Lake Quivira, Kans. 66106

[21] Appl. No.: **09/014,012**

[22] Filed: **Jan. 27, 1998**

Related U.S. Application Data

[60] Provisional application No. 60/036,016, Jan. 28, 1997.

[51] **Int. Cl.**⁷ **A61F 2/06**

[52] **U.S. Cl.** **623/1.13; 623/1.36; 604/215; 606/153**

[58] **Field of Search** 623/1, 11, 12, 623/1.13, 1.36; 604/215; 606/153

[56] References Cited

U.S. PATENT DOCUMENTS

- 5,387,235 2/1995 Chuter .
- 5,397,345 3/1995 Lazarus .
- 5,456,713 10/1995 Chuter .
- 5,464,449 11/1995 Ryan et al. .
- 5,489,295 2/1996 Piplani et al. .
- 5,507,769 4/1996 Marin et al. .
- 5,522,880 6/1996 Barone et al. 623/1
- 5,562,726 10/1996 Chuter .
- 5,562,728 10/1996 Lazarus et al. .
- 5,571,167 11/1996 Maginot .
- 5,571,170 11/1996 Palmaz et al. .
- 5,571,171 11/1996 Barone et al. .
- 5,578,072 11/1996 Barone et al. .
- 5,591,197 1/1997 Orth et al. .
- 5,591,228 1/1997 Edoga .
- 5,591,229 1/1997 Parodi .
- 5,609,625 3/1997 Piplani et al. .
- 5,609,628 3/1997 Keranen .
- 5,628,783 5/1997 Quiachon et al. .
- 5,643,208 7/1997 Parodi .
- 5,662,700 9/1997 Lazarus .
- 5,662,702 9/1997 Keranen .
- 5,669,936 9/1997 Lazarus .
- 5,676,697 10/1997 McDonald .
- 5,683,449 11/1997 Marcade .

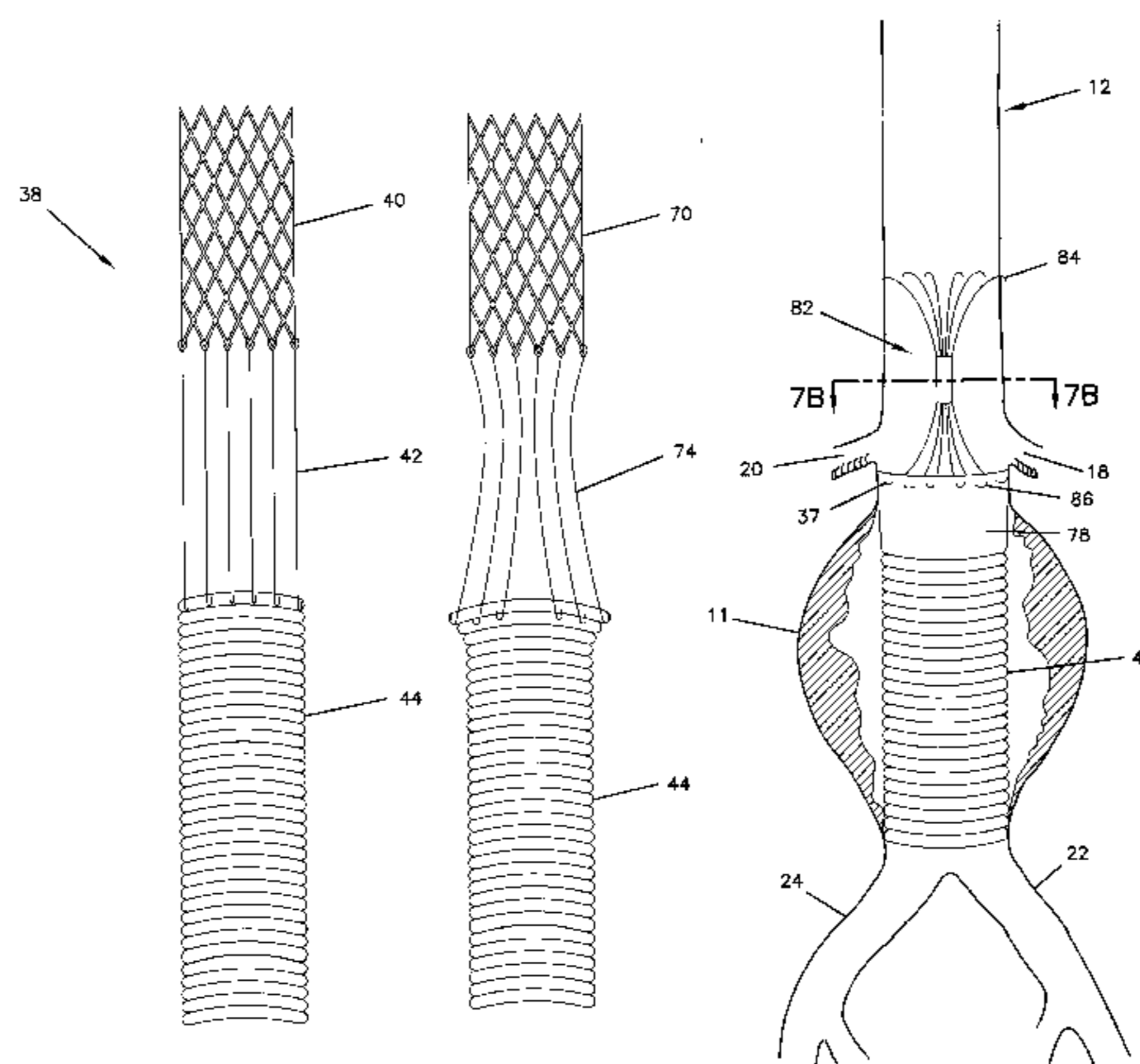

OTHER PUBLICATIONS

Palmaz, J. et al., "Tutorial 16—Intraluminal stents: General principles", pp. 176–182 (publication and date unknown).

Parodi, J. et al., "Endovascular repair of abdominal aortic aneurysms and other arterial lesions", *Journal of Vascular Surgery* 21(4):549–557 (Apr. 1995).

Piquet, P. et al., "Tantalum–Dacron corkscrew stent for endovascular treatment of aortic aneurysms: A preliminary experimental study", *Journal of Vascular Surgery* 19(4):698–706 (Apr. 1994).

White, G. et al., "Three-year experience with the White–Yu endovascular GAD graft for transluminal repair of aortic and iliac aneurysms", *J Endovasc Surg* 4:124–136 (1997).

FIG. 1

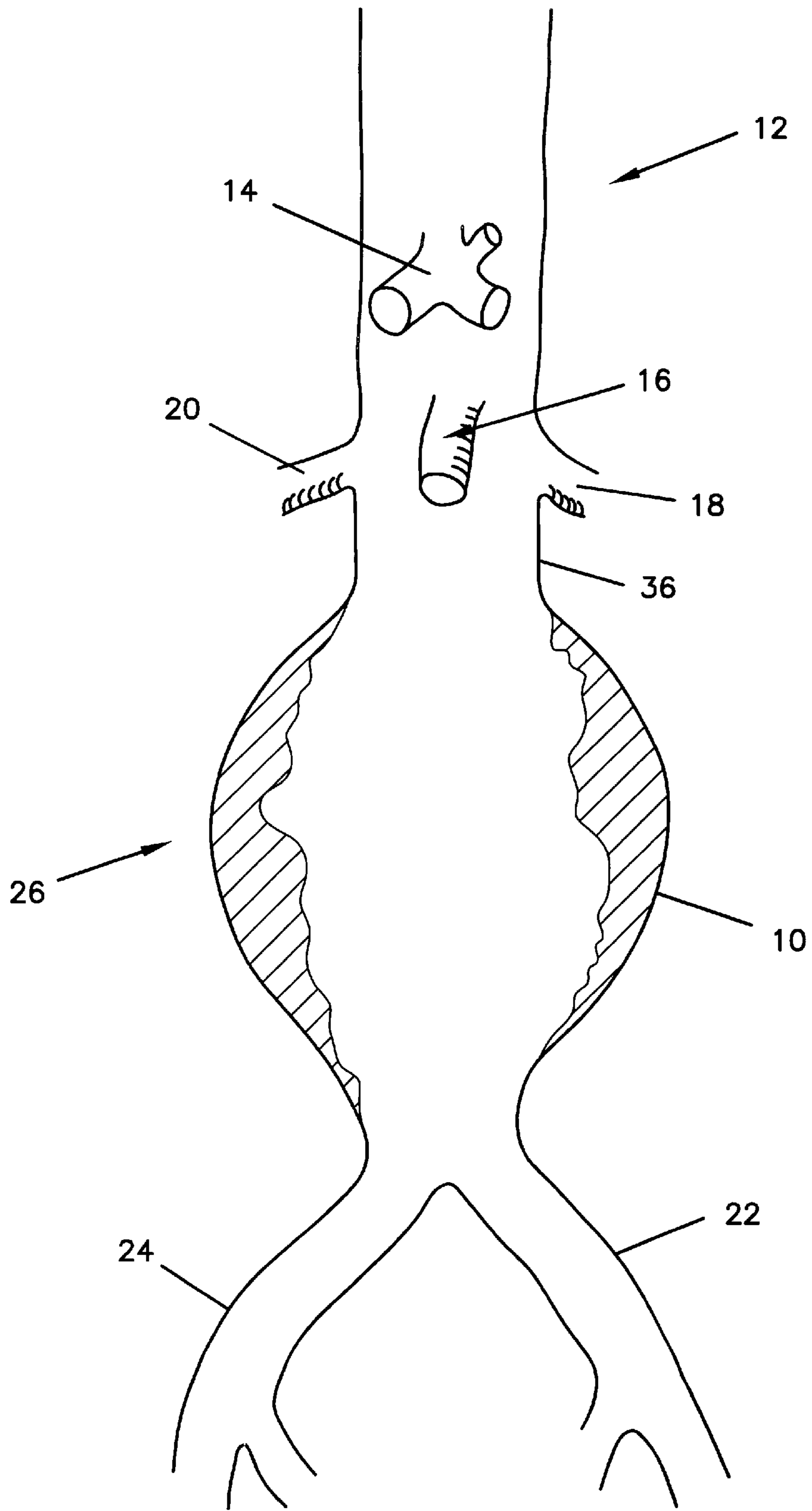

FIG. 2
PRIOR ART

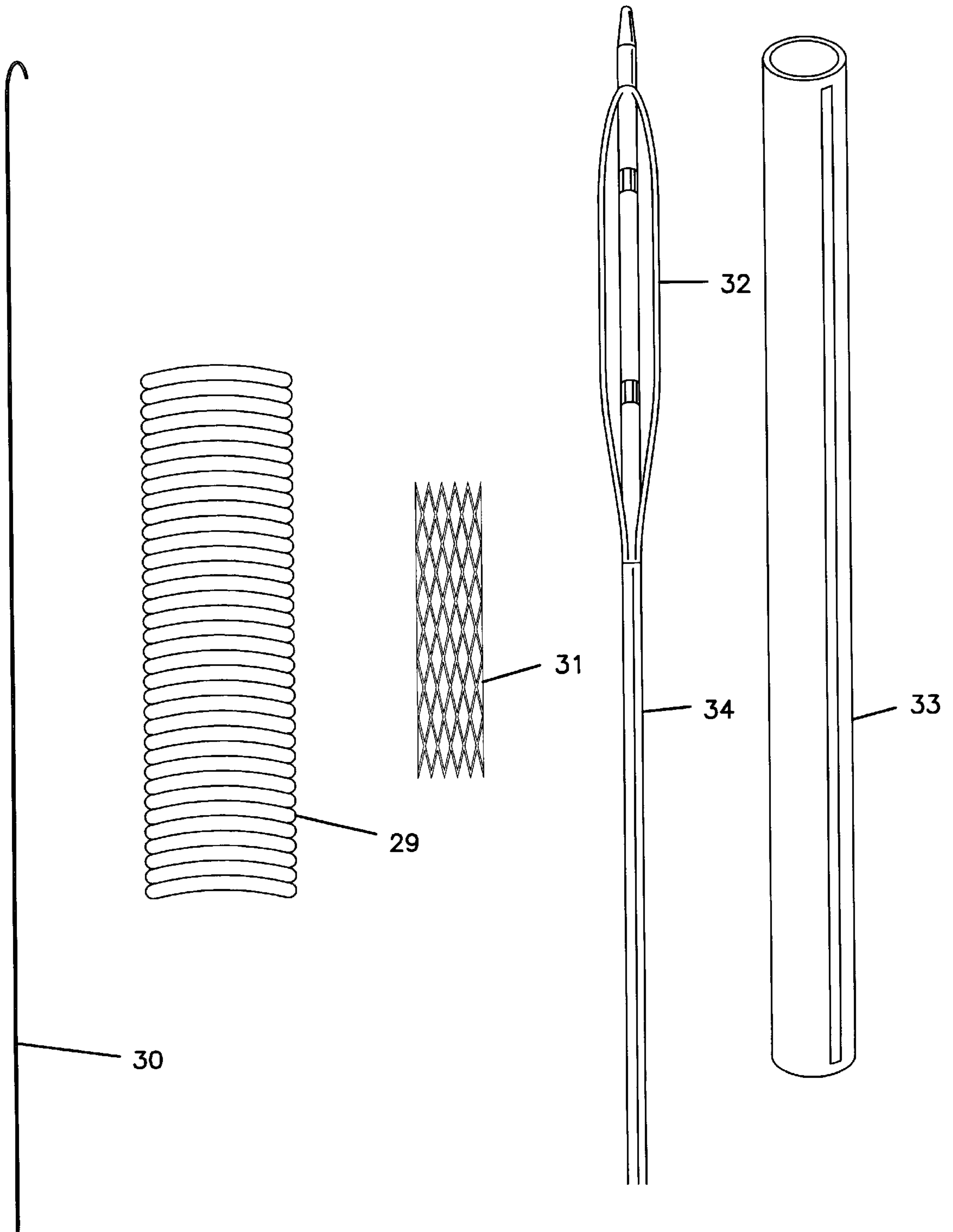

FIG. 3

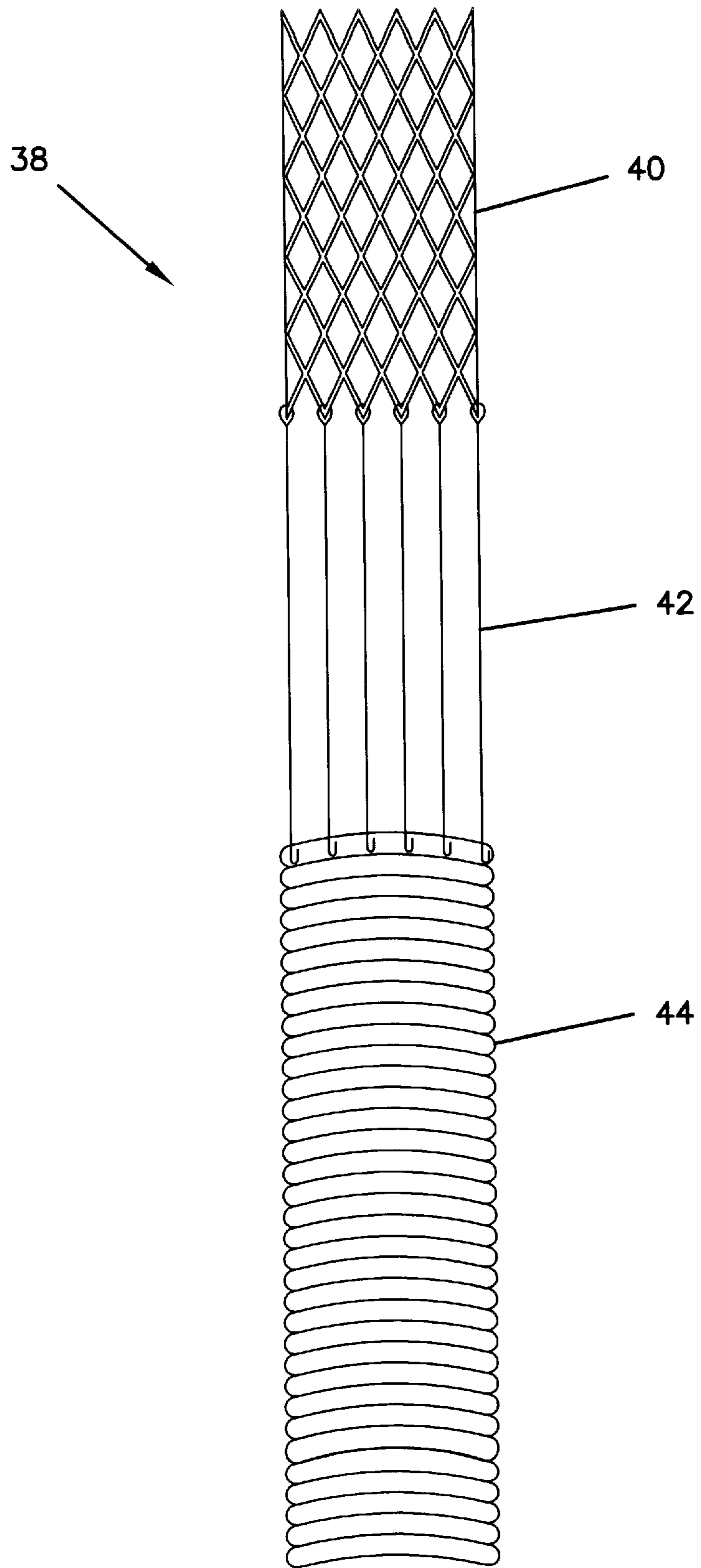

FIG. 4

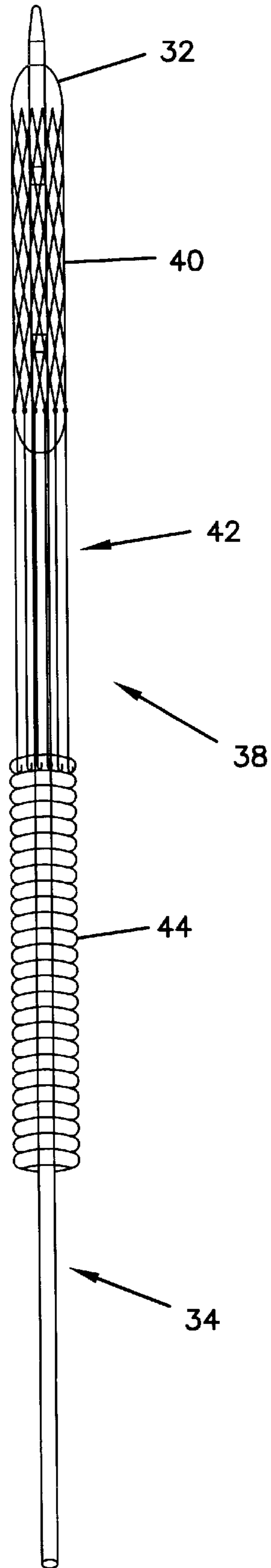

FIG. 5

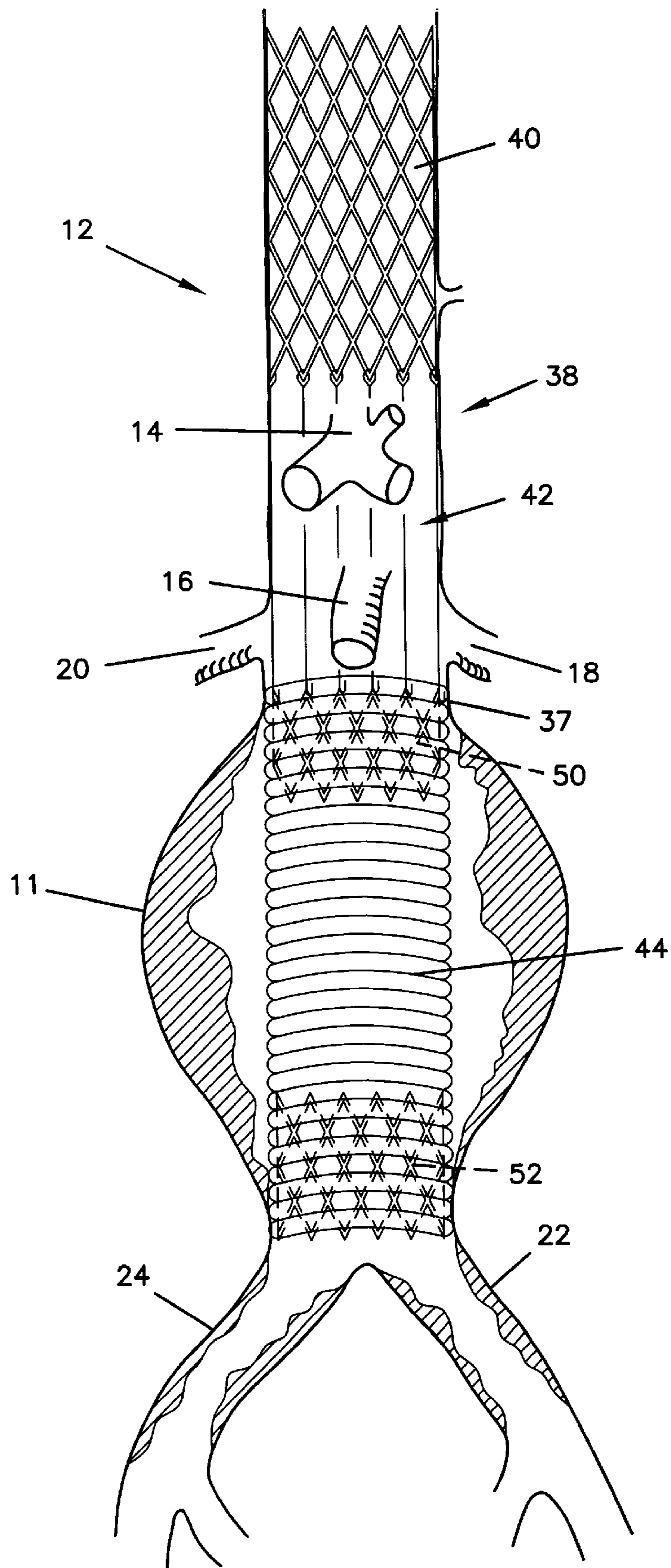

FIG. 6A

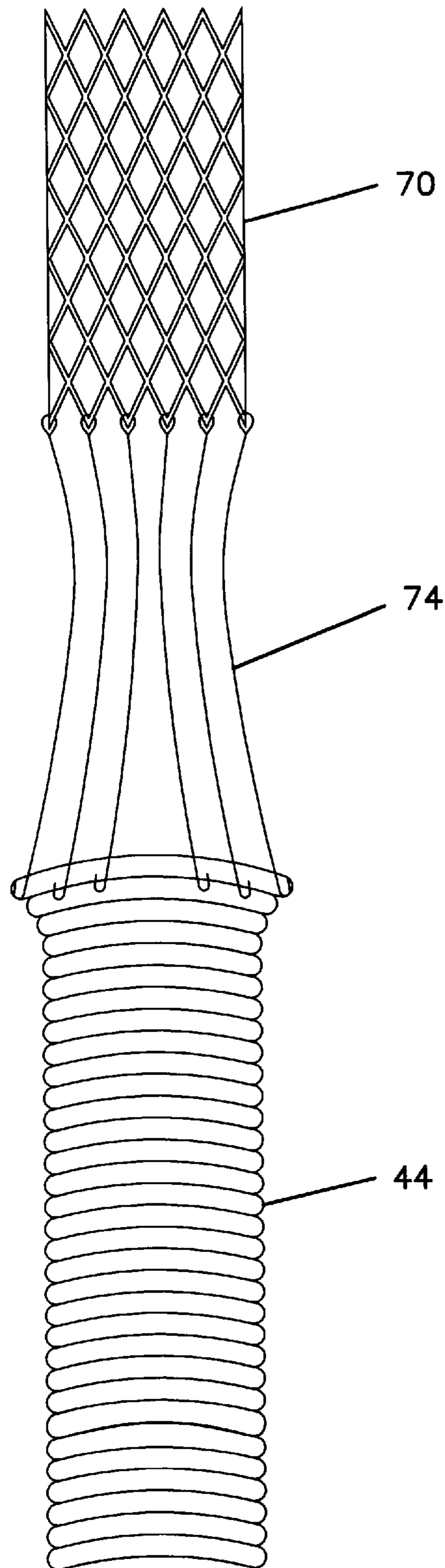

FIG. 6B

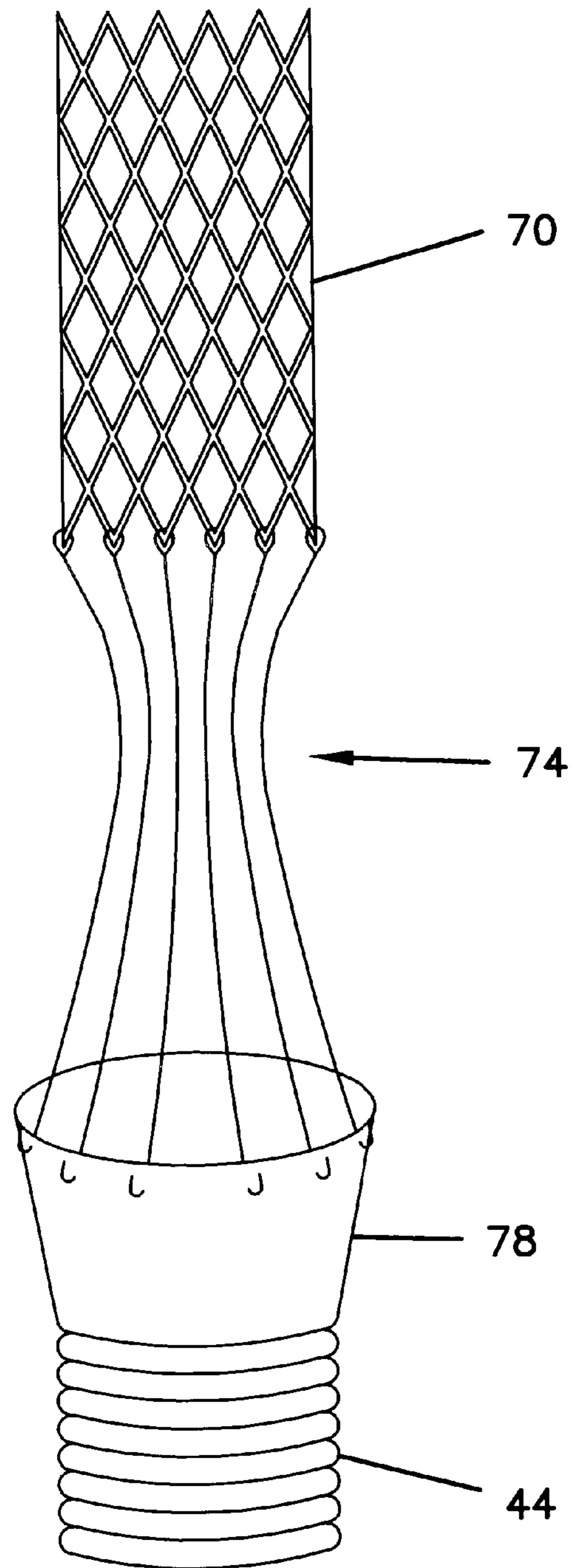

FIG. 7A

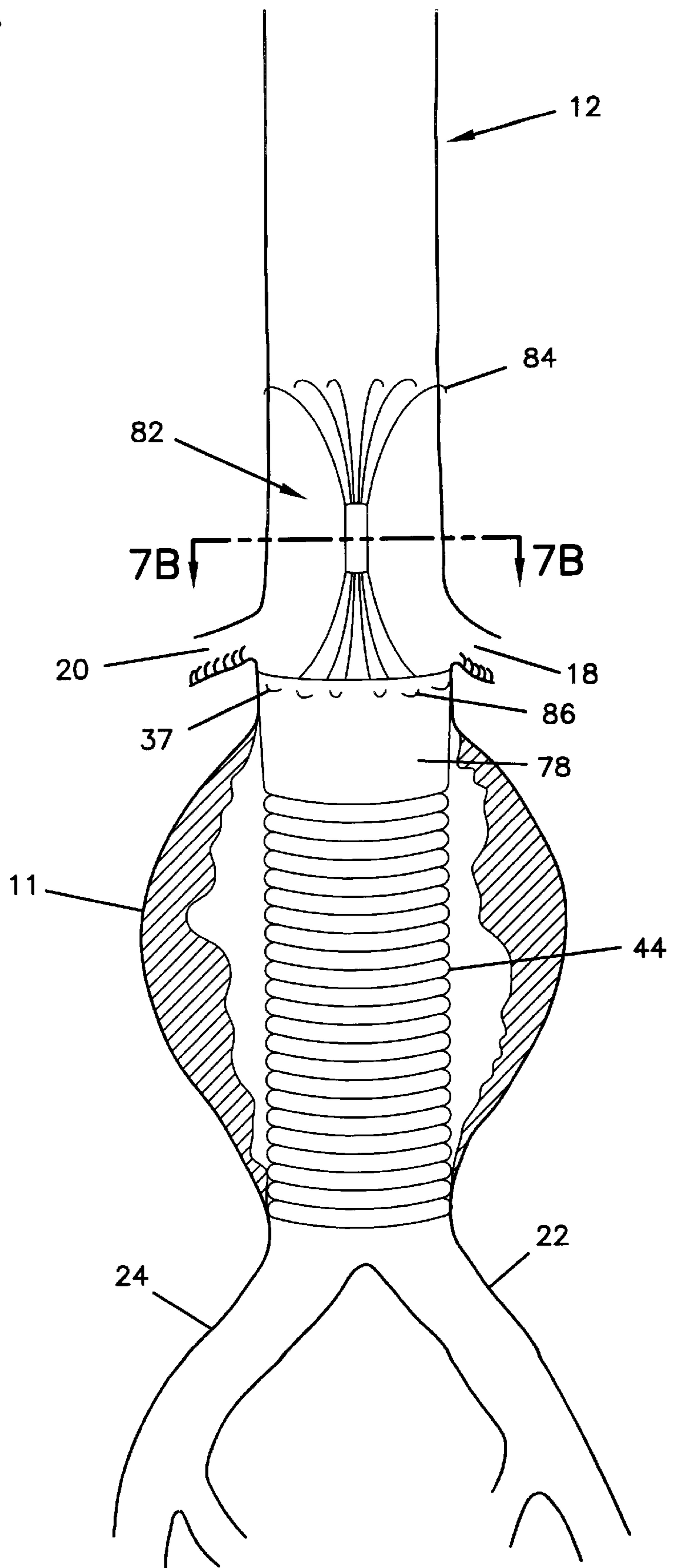

FIG. 7B

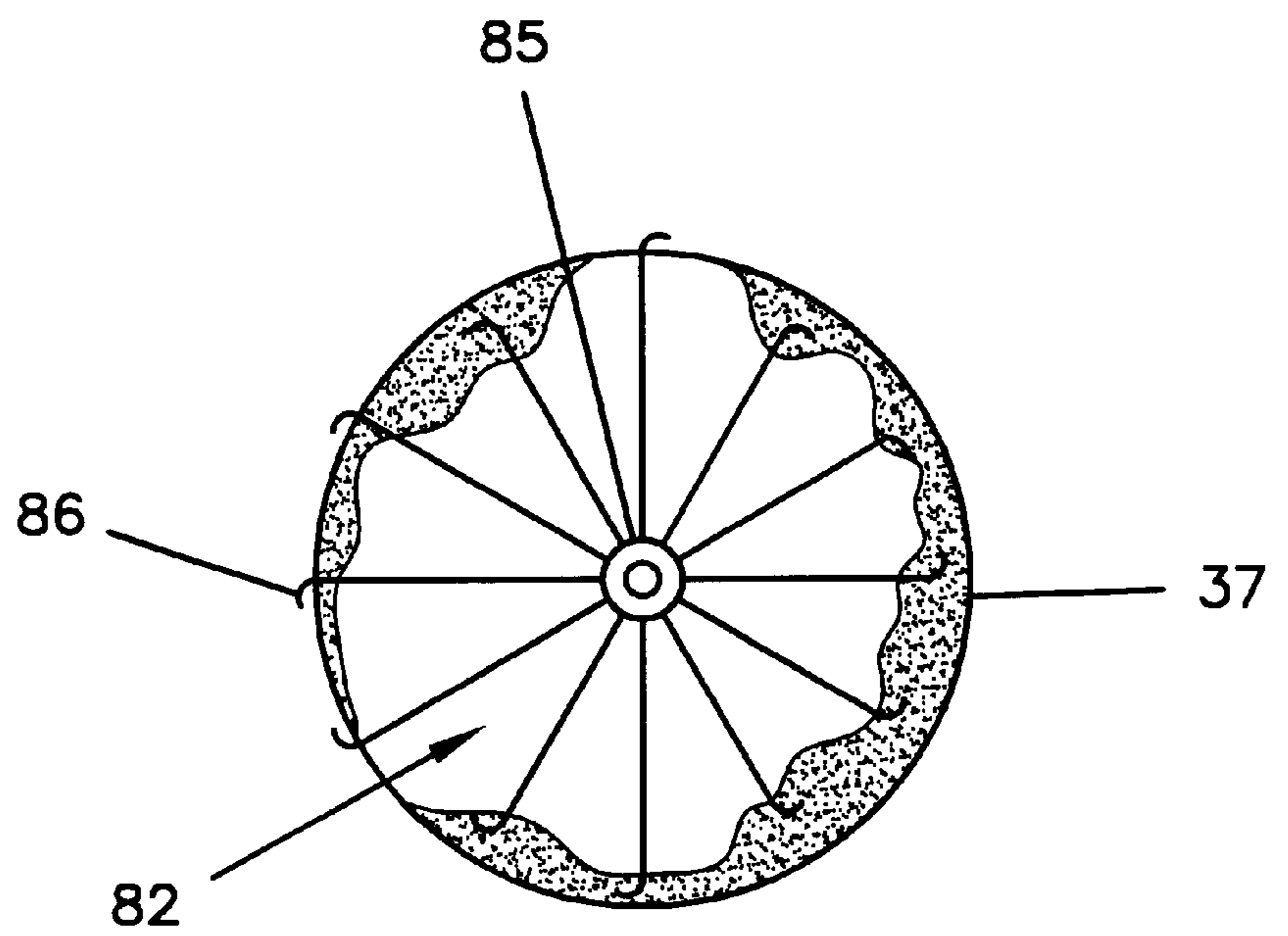
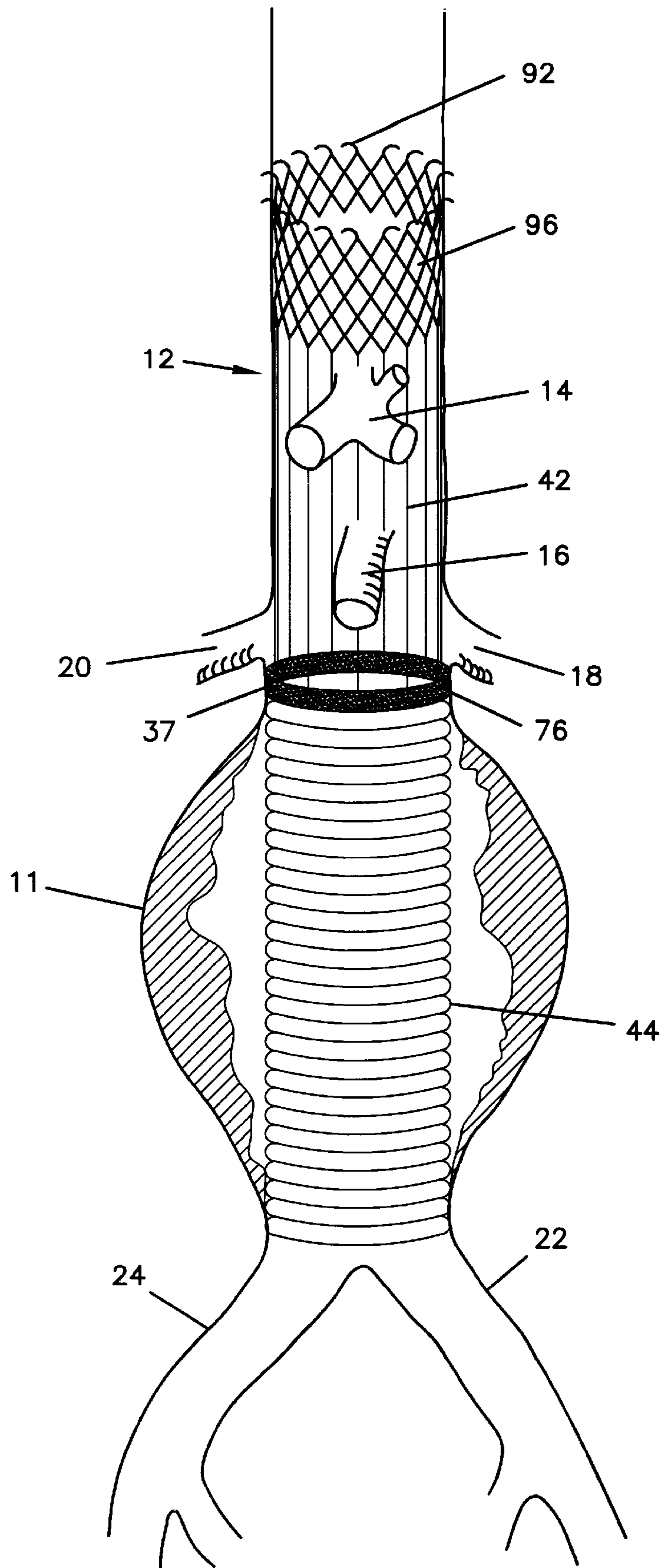

FIG. 8



PROSTHESIS FOR ENDOVASCULAR REPAIR OF ABDOMINAL AORTIC ANEURYSMS

RELATED APPLICATIONS

This application claims priority to United States Provisional Application No. 60/036,016, filed on Jan. 28, 1997, and entitled "Prosthesis for Endovascular Repair of Abdominal Aortic Aneurysms."

BACKGROUND OF THE INVENTION

1. Field of the Invention

The invention relates to vascular prostheses, and more particularly, to prostheses for endovascular repair of aortic aneurysms.

2. Description of Related Art

An aneurysm is a localized dilatation or weak spot in a blood vessel. Abdominal aortic aneurysms are one of the most common and serious types of aneurysm. They are thought to be atherosclerotic in origin, i.e., related to a high fat diet, high blood pressure, and cigarette smoking. But genetic factors that control collagen and/or elastic tissue metabolism may also be involved.

A common abdominal aortic aneurysm **10** is illustrated in FIG. 1. The aorta **12** is the large artery that arises directly from the heart. After it passes below the diaphragm, into the abdomen, the aorta **12** gives off major branches that supply the liver, stomach and spleen (the hepatic, left gastric and splenic arteries, the common trunk of which is the coeliac artery **14**), the intestines (superior mesenteric artery **16**), and the kidneys (renal arteries **18, 20**). It then divides into right and left trunks **22, 24**, called iliac arteries, which supply circulation to the legs.

Abdominal aortic aneurysms **10** most often develop in the relatively long segment **26** of aorta between the renal arteries **18, 20** and the bifurcation of the aorta into the right and left iliac arteries **22, 24**. Abdominal aortic aneurysms **10** progressively enlarge at variable and unpredictable rates, and as they do, the involved aneurysm wall becomes weaker and thinner, and eventually ruptures. Rupture is relatively uncommon in abdominal aortic aneurysms less than five centimeters maximum transverse diameter, but the risk increases with increasing size. Rupture of abdominal aortic aneurysms causes approximately 15,000 deaths per year in the United States.

Surgery to prevent rupture is recommended for most patients with abdominal aortic aneurysms five centimeters maximum transverse diameter or greater. Presently approximately 40,000 of these operations are performed each year in the United States.

The standard operation involves a long midline incision in the abdominal wall that extends from the lower end of the sternum to the pubic bone. Blood flow through the aneurysm is temporarily stopped by occluding the aorta with a clamp placed above the aneurysm **10** and clamps placed across the right and left iliac arteries **22, 24**, which are below the aneurysm. The aneurysm **10** is opened, and a plastic fabric tube graft is anastomosed (i.e., joined) to the normal, non-dilated aorta above the aneurysm **10**. The other end of the tube graft is joined to the non-dilated aorta below the aneurysm **10**.

Thus, the diseased segment (i.e., aneurysm) is replaced by a plastic tube. The anastomoses (i.e., junctions) between the aorta and the graft are sewn with surgical sutures. In some patients, a bifurcated graft in place of a single tube graft

must be used. These grafts are shaped like an inverted "Y". The single trunk is joined to the proximal aorta and the right and left limbs are joined distally to the right and left iliac arteries (herein the words proximal and distal are used with the heart being the point of reference). These inverted Y grafts are used in patients who have no segment of non-dilated aorta below the aneurysm.

This major operation can be performed in relatively good-risk patients with a mortality rate of less than five percent. However, the operation requires five to ten days of postoperative hospital care and a four to six week recovery period. Furthermore, the operation cannot be safely performed in many patients with severe cardiac or pulmonary impairment.

Recently, alternative methods of repair that do not involve the large, open abdominal incision have been developed. One of these is the so-called "endovascular" approach. With the endovascular approach, a small incision is made in a groin to form a small opening in one of the iliac arteries **22**. A guide wire **30** (FIG. 2) is passed up through the iliac artery **22** into the aorta **12** and through the aneurysm **10**, under continuous X-ray, i.e., fluoroscopic control. A soft plastic fabric tube graft **29** is placed over a metal mesh stent **31** (in its non-extended state) which is mounted over the balloon portion **32** (non-distended) of a large angioplasty type catheter **34**. The fabric graft is folded longitudinally so that the entire apparatus (i.e., plastic graft, underlying stent and balloon angioplasty catheter) can be loaded into a flexible plastic sheath **33** (e.g., Teflon™) and passed into the lumen of the iliac artery **22** and up into the aneurysm **10**. Once the prosthesis is properly positioned, the sheath **33** is withdrawn.

Proximal fixation of the graft is accomplished with the underlying stent. The upper end of the graft is secured by the stent to the segment of non-dilated aorta **36** just above the aneurysm **10**. This segment **36** that lies above the aneurysm but below the renal arteries is sometimes referred to as the "neck" of the aneurysm (and will be referred to as such herein), although it is not actually a part of the aneurysm. After withdrawal of the delivery sheath **33**, the balloon **32** is distended to expand the stent **31** so that the stent **31** presses the outer wall of the graft **29** against the inner wall of the neck **36** of the aneurysm. An alternative method of fixation involves a ring of interconnected, fine-metal hooks or barbs pre-sewn into the upper end of the graft. The metal hooks or barbs are "fired" into the wall of the neck of the aneurysm by inflation of the catheter balloon **32**. Yet another known method is a combination of a stent and hooks or barbs, in which the hooks or barbs are welded to the stent.

Proper proximal fixation of the graft to the aorta is important for two reasons. One, proximal fixation prevents leaks to the outside of the graft, leaks which would maintain high arterial pressure within the abdominal aortic aneurysm and lead to progressive enlargement and rupture. Two, proximal fixation prevents distal migration and collapse of the soft plastic fabric tube graft by the force of arterial blood flow. Over time, fibrous tissue grows from the aortic wall into the interstices of the porous fabric graft providing some additional fixation.

Blood pressure and flow tend to keep the lower end of the graft expanded against the aortic wall by a so-called "parachute" effect. However, distal fixation of the graft is generally accomplished by placement of a second short, expandable metal stent similar to the stent used in the upper end. The second stent is expanded at the lower end of the graft so that the stent presses the outer wall of the graft against the inner wall of the aorta below the aneurysm.

There are several major unsolved problems with proximal fixation of endovascular grafts that limit their application in the repair of many abdominal aortic aneurysms. One such problem is that the aneurysm neck **36** is often too short to permit adequate fixation with an expandable stent. (Generally, a length of two centimeters or more is needed for adequate anchoring of the graft.) Additionally, the aneurysm neck is frequently too heavily calcified to permit fixation with hooks, i.e., the hooks cannot penetrate areas of the aortic wall that have thick, calcified plaques. In other cases, the inner wall of the neck is thickened by soft, friable plaque or thrombus that makes fixation with hooks impossible or inadequate.

SUMMARY OF THE INVENTION

To permit wider application of endovascular repair of aortic aneurysms, and to overcome other limitations in the prior art, the present invention discloses a new apparatus for endovascular repair of aortic aneurysms. In one form, the invention comprises a prosthesis including a tube and an anchoring unit that includes a plurality of thin lines. The tube provides a conduit for blood flow through an aortic aneurysm. First end of lines are connected to a first end of the tube. Second end of the lines are separated by a distance from the first end of the tube for anchoring the prosthesis at a location away from the aneurysm.

In one embodiment, the prosthesis is constructed for repairing an abdominal aortic aneurysm between the renal and iliac arteries. The tube extends at least the length of the aneurysm. The plurality of lines extend from the first end of the tube to a position above the coeliac artery, where the prosthesis is anchored.

In one embodiment of the invention, the anchoring unit further includes an expandable stent connected to the second end of the plurality of lines. Furthermore, in one embodiment of the invention, the plurality of lines are curved so that the first end of the plurality of lines pushes, from a compressed state, radially outward so as to conform to the shape of an aortic wall and to exert a pressure thereon. Additionally, in one embodiment of the invention, the second end of the plurality of lines is sharp and the plurality of lines are curved so that the second end of the plurality of lines pushes, from a compressed state, radially outward so as to embed in an aortic wall to anchor the prosthesis.

The invention includes several other features and embodiments. The claims annexed hereto and forming a part hereof point out with particularity various embodiments and features of novelty which characterize the invention. The drawings and accompanying descriptive matter herein illustrate and describe specific examples of an apparatus formed in accordance with invention.

BRIEF DESCRIPTION OF THE DRAWINGS

Referring now to the drawings in which like reference numbers represent corresponding parts throughout:

FIG. 1 is a pictorial diagram of an aneurysmal abdominal aorta;

FIG. 2 is a pictorial diagram of a guide wire, a graft, a stent, a balloon catheter, and a flexible delivery sheath;

FIG. 3 is a pictorial diagram of a prosthesis formed in accordance with the invention;

FIG. 4 is a pictorial diagram showing the prosthesis of FIG. 3 loaded on a balloon catheter in accordance with the invention;

FIG. 5 is a pictorial diagram showing the prosthesis of FIG. 3 installed in a short-neck aneurysmal abdominal aorta in accordance with certain aspects of the invention;

FIGS. 6a and 6b are pictorial diagrams showing other embodiments of the prosthesis provided by the invention;

FIG. 7a is pictorial diagram showing another embodiment of the prosthesis provided by the invention installed in a short-neck aneurysmal abdominal aorta;

FIG. 7b is a cross-sectional view taken along section line 7b—7b of FIG. 7a; and

FIG. 8 is pictorial diagram showing another embodiment of the prosthesis provided by the invention installed in a short-neck aneurysmal abdominal aorta.

DETAILED DESCRIPTION OF PREFERRED EMBODIMENTS

FIG. 3 depicts one preferred embodiment of the invention. The prosthesis **38** includes an expandable stent **40** (shown in its expanded state), connecting wires **42**, and a tubular graft **44**. The upper ends of the connecting wires **42** are connected to the lower end of the expandable stent **40**, and the lower ends of the connecting wires **42** are connected to the upper end of the graft **44**. FIG. 4 depicts this embodiment of the invention loaded on a balloon catheter with the stent in its non-expanded state, as explained in greater detail below. In one preferred embodiment, a flexible, plastic sheath **33** (as illustrated in FIG. 2) is placed over the prosthesis **38** for delivery of the prosthesis. (The sheath **33** is not shown in FIG. 4.)

The connecting wires **42** and metal stent **40** allow fixing the upper end of the prosthesis **38** to a segment of aorta that is separate and apart from the aortic position of the graft **44** itself. Thus, fixation can be made at a segment of the aorta that is much better suited for anchoring the graft because, e.g., it is much less frequently and severely diseased and is greater in length than the diseased “neck” of the aneurysm.

FIG. 5, for example, depicts one preferred way of implanting the prosthesis **38** to repair an abdominal aortic aneurysm **11** with a short neck **37**. The graft **44** is positioned within the aneurysm **11**, with the graft's upper end positioned just below the orifices of the renal arteries **18, 20**. The stent **40** is positioned within the lumen of the aorta **12** above the coeliac artery **14**, commonly referred to as the supra-coeliac portion of the aorta. This segment of the aorta is much less frequently diseased and it has a much smoother lumen than the segment below the renal arteries **18, 20**. It is much less likely to be heavily calcified or lined by irregular soft plaque and thrombus. Hence, the stent **40** can be more effectively affixed to this portion of the aorta.

The connecting wires **42** pass through the portion of the aorta **12** from which the coeliac, mesenteric and renal arteries **14, 16, 18** and **20** originate. The wires **42** allow blood to flow between the aorta **12** and the coeliac, mesenteric and renal arteries, i.e., without obstructing or occluding these arteries. The wires are preferably long enough to at least span the short segment of the aorta from which the coeliac, mesenteric and renal arteries originate so that neither the stent **40** nor the graft **44** obstructs these arteries.

The following are materials that are used to construct one preferred embodiment of the prosthesis; other materials can also be used. The tubular graft **44** is preferably formed of a collapsible plastic fabric such as a Dacron™ or e-PTFE (e.g., Gore Tex™) fabric; such grafts are known in the art. As one alternative, the graft **44** could be constituted by a self-expandable nitinol wire framework covered externally or lined internally by a very thin layer of Dacron™ or e-PTFE, as has recently become known in the art. Also as has recently become known in the art, the graft **44** can be either a single unit or a modular device consisting of two or more parts which can be inserted separately.

The connecting wires **42** are preferably constructed of a thin, flexible metal, such as stainless steel, titanium or nitinol. The wires are sufficiently thin so that they will not obstruct blood flow into the coeliac, mesenteric or renal arteries, and the wires are nonthrombogenic, i.e., they do not incite clot formation. Such wires have been successfully used in the Greenfield vena cava filter for 10–20 years. In one preferred embodiment, 6 to 10 wires **42** are placed at regular intervals around the circumference of the stent **40** and graft **44**; other numbers of wires could also be used. The wires **42** are connected to the stent **40** and graft **44** by, for example, loops or semi-closed hooks formed at the ends of the wires **42**. Alternatively, fine, flexible monofilament polypropylene could be used in place of the metal wires **42**. Like the wires, the polypropylene filaments would be of such fine caliber that they will not obstruct the coeliac **14**, mesenteric **16** or renal **18, 20** arteries, so that they can be spaced around the entire **360** degree circumference of the upper stent **40** and graft **44**. Alternatively, to further reduce the risk of obstruction of or embolization into these arteries, which originate from the anterior wall of the aorta (i.e., from the anterior 180 degrees in a cross-sectional plane), the wires or polypropylene filaments could be limited to the posterior 180–210 degrees of the circumferences of the upper stent **40** and graft **44**.

The stent **40** is preferably formed of stainless steel, titanium or nitinol. The stent **40** is expandable, but once expanded cannot be easily contracted so that the expanded stent maintains pressure against the inner wall of the aorta **12**. Such stents are known in the art. In one preferred embodiment, the stent **40** is approximately three to four centimeters in length. However, various dimensions for the stent **40**, wires **42**, and graft **44** can be used, and the dimensions can be varied depending on the application of the prosthesis and the patient's dimensions. The stent **40** is depicted as a balloon-expandable stent. However, a nitinol self expanding stent, as is known in the art and does not require a balloon for expansion, could also be used. Such stents require a somewhat different delivery system, as is known in the art.

The prosthesis **38** is in one preferred embodiment installed using an angioplasty catheter **34**. The prosthesis is loaded onto a catheter **34** in collapsed form as shown in FIG. **4**. The stent **40** in non-expanded form is placed over the collapsed balloon **32** of the catheter **34**. The connecting wires **42** and graft **44** are compressed over the catheter **34** below the stent **40**. The “collapsed” prosthesis **38** is preferably placed inside a flexible, plastic sheath **33** (e.g., Teflon™) for delivery into the iliac artery and aorta.

The prosthesis **38** offers another advantage over the current endovascular prosthesis described above in the section titled “Description of Related Art.” With that prosthesis, a tubular graft is placed over a catheter balloon and an expandable stent. The combined stent and graft over the balloon catheter creates a greater diameter of the combined prosthesis and balloon. With the greater diameter, it is more difficult to pass the device through the iliac arteries, which are often narrowed or tortuous. In contrast, with the preferred form of the present invention, the graft **44** is not positioned over the balloon and stent **40**, but rather only over the catheter **34**; the outer diameter of the device is therefore smaller.

The catheter **34** with the prosthesis **38** is passed into and positioned in the aorta **12** as follows. An incision is made in the right or left groin and a short cannula or “introducer” is inserted into either the common femoral or the external iliac artery. Under fluoroscopic control, a guide wire **30** is passed

through the external iliac artery, the common iliac artery **22, 24**, the aneurysm **11**, and up into the supracoeliac aorta above the coeliac artery **14**. Then, the catheter **34** bearing the collapsed prosthesis **38**, placed inside a thin walled plastic delivery sheath **33** (e.g., Teflon™), is passed over the guide wire, through the same path, up into the supracoeliac aorta, also under fluoroscopic control.

When the stent **40** has been advanced just beyond the coeliac artery **14**, the delivery sheath **33** is withdrawn and the balloon **32** is inflated to expand the stent **40** against the inner wall of the supracoeliac segment of the aorta, to secure the stent at that position. The balloon is then collapsed, freeing it from the stent, and the catheter **34** is withdrawn, leaving the prosthesis **38** positioned as shown in FIG. **5**.

In one preferred embodiment, two additional expandable stents **50, 52** are used to further fix the graft **44**. These stents **50, 52** are shown in broken lines in FIG. **5**. The construction of the stents **50, 52** can be generally the same as that of the stent **40** positioned at the supracoeliac aorta. However, the stents **50, 52** are preferably shorter than the stent **40**. The stent **50** is used to press the upper end of the graft **44** against the inner wall of the neck **37** of the aneurysm, so as to obstruct blood flow outside of the graft through the aneurysm **11**. The stent **52** is used to press the lower end of the graft **44** against the inner wall of the aorta just below the aneurysm **11**.

In one preferred embodiment, the stents **50, 52** are successively positioned using a balloon catheter **34** in manner similar to the positioning of the prosthesis **38** with the stent **40**. The stent **50**, in non-expanded form, is placed over a collapsed balloon **32** of a catheter **34**. The catheter **34**, bearing the stent **50** placed inside a sheath **33** (e.g., Teflon™), is passed over the guide wire **30** into the aorta **12** through the graft **44** and positioned at the neck **37** of the aneurysm **11**, just below the line of attachment of the connecting wires **42**. The sheath **33** is then withdrawn and the balloon **32** expanded to expand the stent **50** as shown in FIG. **5**. This stent **50** helps to maintain the graft **44** in cylindrical conformation and expanded against the aortic wall to prevent blood flow outside the graft into the aneurysm. The catheter **34** is then withdrawn. While the stent **50** is sufficient to maintain the graft **44** open and to help prevent leaks, it would generally be insufficient by itself to adequately anchor the graft **44** and prevent distal migration of the graft **44** in patients who have a short aneurysm neck **37**, as is common.

The stent **52**, in non-expanded form, is placed over a balloon **32** of a catheter **34** and is installed in a similar manner. The stent **52** is positioned at the lower portion of the graft **44** to help seal the graft against the wall of the distal aorta, as shown in FIG. **5**. Alternatively, if the aneurysm **11** extends to the iliac arteries so that the stent **52** cannot be satisfactorily fixed to the distal aorta, the graft **44** can be dimensioned to extend into the right or left iliac artery **22, 24** and the stent **52** fixed there at the iliac artery. In this case, the opposite iliac artery is permanently occluded by a catheter-placed endoluminal device and a crossover vascular graft performed between the right and left external iliac arteries, or the common femoral arteries, to maintain blood flow to the opposite leg, as is sometimes done with current prostheses and as is known in the art.

Further as is sometimes done with current prostheses and as is known in the art, in another alternative, an “inverted Y” bifurcated graft is used. The second limb of the graft is “snared” by a catheter advanced through the contralateral iliac artery and the end of this limb is pulled down into the

contralateral iliac artery and secured with a fourth stent. In this embodiment, a crossover vascular graft is not needed.

Another embodiment of the invention is illustrated in FIG. 6a. In this embodiment, a metal stent 70 is connected to the graft 44 by thin, elastic metal wires 74 that, from the stent, curve radially, first inward and then outward. The wires 74 are, at one end, rigidly attached to the lower end of the stent 70 and, at their other end, are attached to the upper end of the graft 44, so that the lower ends of the extensions 74 press radially outward. The wires 74 are dimensioned so that they extend from the aneurysm neck 37 to above coeliac arteries 14 (not shown in FIG. 6a). When the delivery sheath 33 is pulled back, these wires 74 press the upper end of the graft 44 against the neck of the aneurysm, to help seal the graft against the aneurysm neck. With this embodiment, a stent 50 may not be necessary at the neck of the aneurysm, as the outward pressure of the wires 74 would in most cases be sufficient to seal the upper end of the graft against the aneurysm neck 37. However, this embodiment of the invention does not preclude the use of a stent 50 at the upper end of the graft 44.

Because the wires 74 press radially outward independent of one another, the wires can extend to conform to the shape of an irregularly-shaped (e.g., not perfectly cylindrical) aneurysm neck 37, thereby improving the seal. To take advantage of this, as indicated in FIG. 6a, the upper end of the graft 44 to which the wires 74 are attached preferably readily stretches circumferentially, so that the upper end can conform to an irregularly-shaped aneurysm neck under the pressure of the wires 74. In one preferred embodiment, depicted in FIG. 6b, the circumferentially stretchable upper end 78 is one to two centimeters wide (measured along the graft's longitudinal axis). A suitable material for the upper end 78 is e-PTFE fabricated to stretch circumferentially, as will be recognized by those skilled in the art. (Tubular grafts of e-PTFE fabricated to stretch longitudinally exist and are used for open or trans-abdominal repair of abdominal aortic aneurysms.)

FIG. 7a illustrates another embodiment of the invention, in which the stent 40 and connecting wires 42 are replaced by a single unit 82 composed of thin, pre-curved, elastic wires that are joined together near their mid-sections and, from their mid-sections, curve radially outward. The wires of the unit 82 are compressed together when loaded into a delivery catheter sheath or cartridge, and spring out radially once released from the sheath or cartridge. The upper ends 84 of the wires have sharp angled end points that function as prongs that embed in the supraceliac aortic wall to secure the unit 82. The lower ends 86 are attached to the upper end of the graft 44 by small rings or hooks. The lower ends 86 press out radially, independently of each other to seal the graft 44 against the aneurysm neck 37. As a result, the ends of the unit 82 can conform to an irregular (e.g., non-cylindrical) surface, as illustrated in cross-sectional plane view in FIG. 7b.

The unit 82 is dimensioned so that the wires extend from the aneurysm neck 37 to above coeliac arteries 14 (not shown in FIG. 7a). In one preferred embodiment, the wires are formed of curved stainless steel or titanium wires that are welded together near their mid-sections. Also in one preferred embodiment, the upper end 78 of the graft 44 is formed to be circumferentially stretchable, as described with respect to FIGS. 6a and 6b. Furthermore, as illustrated in FIG. 7b, in one preferred embodiment the midsection of the unit 82 has a central lumen 85 for a guide wire for use in delivering the prosthesis. A modified delivery system may be required for the delivery and positioning of this prosthe-

sis. A stent 52 (not shown) may also be used for securing the lower end of the graft 44, as described with respect to FIG. 5.

FIG. 8 illustrates yet another embodiment of the invention in which the graft 44 is modified by the addition of a collar 76 of highly compressible, elastic material at the upper end of the graft 44. The collar 76 is preformed to expand radially once the delivery sheath 33 is pulled back, to help seal or close any small spaces between the graft and the neck of the aneurysm 37. In one preferred embodiment, the collar 76 is approximately one centimeter wide (measured along the graft's longitudinal axis) and is joined to the graft 44 above the line of attachment of the connecting wires 42 to the graft 44. Examples of materials that could be used for the collar 76 include very loosely knitted or velour Dacron™, highly porous e-PTFE or Teflon™ "felt." The highly compressible, elastic collar 76 could also be added to the upper end of the circumferentially stretchable upper end of the graft 44 that is described with respect to FIGS. 6a and 6b, to further improve the seal to an irregular aneurysm neck 37.

Within the scope of the invention, various further changes can be made to the embodiments described above. For example, the expandable stent 40 can be replaced with an expandable ring of small metal hooks, which can be "fired" into the inner wall of the aorta with a balloon catheter using distention of the balloon to drive the hooks into the aortic wall. Also, the expandable stents 40 and 70 (shown in FIGS. 5 and 6) can be modified by the addition of small metal barbs to the outer surface of the stent to help secure the stents to the aortic wall and prevent downstream migration. For example, FIG. 8 shows an expandable stent 90 having elastic metal barbs 92 at the upper end of the stent 90. The barbs 92 can be compressed when covered by the delivery sheath 33 and then spring radially outward when the delivery sheath 33 is withdrawn. The barbs 92 preferably have sharp ends which embed into the wall of the supraceliac aorta.

Furthermore, while the invention has been illustrated for the repair of abdominal aortic aneurysms, the invention might be used to repair other aortic aneurysms, e.g., certain thoracic aortic aneurysms.

Therefore, it is to be understood that the foregoing description of exemplary embodiments of the invention has been presented for the purposes of illustration and description. It is not intended to be exhaustive or to limit the invention to the precise forms disclosed. Many further modifications and variations are possible in light of the above teaching. The scope of the invention is not to be limited to this detailed description, but rather by the claims appended hereto.

What is claimed is:

1. An apparatus for repairing an aneurysm of an aorta, the aorta including a region from which coeliac, mesenteric and renal arteries originate, the aneurysm being located along a section of the aorta positioned between the renal and iliac arteries, the apparatus including:

- a) a tube to serve as a conduit for blood flow in the aneurysm of the aorta, the tube being dimensioned in length to at least extend a length of the aneurysm;
- b) an anchor, separated by a distance from the tube, to secure the apparatus within the aorta, the anchor being dimensioned for being set above the coeliac artery; and
- c) a plurality of thin lines interconnecting the anchor and the tube, the lines being dimensioned to a length greater than a length of the region of the aorta from which the coeliac, mesenteric and renal arteries originate, the plurality of thin lines including at least six thin lines

spaced about a circumference of the tube, each of the lines being sufficiently thin so as to not obstruct blood flow to the coeliac, mesenteric and renal arteries regardless of the angular orientation of the tube and the anchor within the aorta.

2. The apparatus of claim 1, wherein the plurality of lines are flexible metal wires.

3. The apparatus of claim 1, wherein the plurality of lines are flexible monofilaments.

4. The apparatus of claim 1, wherein the plurality of lines are evenly distributed about the circumference of the tube.

5. The apparatus of claim 1, wherein the plurality of lines curve radially outward at a first end of the tube to which the lines are connected, to push the first end of the tube against an aortic wall.

6. The apparatus of claim 5, wherein the first end of the tube is circumferentially stretchable, so that the first end of the tube can conform to the shape of an aortic wall.

7. The apparatus of claim 1, wherein the tube includes a collar of compressible, elastic material at a first end of the tube to which the plurality of lines are attached, wherein the collar expands radially to conform to an aortic wall.

8. The apparatus of claim 1, wherein the anchor is an expandable metal stent.

9. A prosthesis for repairing an aneurysm of an aorta, the aorta including a region from which coeliac, mesenteric and renal arteries originate, the aneurysm being located along a section of the aorta positioned between the renal and iliac arteries, the prosthesis including:

a tube having first and second ends, to serve as a conduit for blood flow in the aneurysm of the aorta, the tube being dimensioned in length to at least extend a length of the aneurysm;

an anchoring unit including a plurality of thin lines connected at first ends to the first end of the tube, wherein second ends of the lines are separated by a distance from the first end of the tube for anchoring the prosthesis to an aortic wall at a location away from the aneurysm, the plurality of lines being dimensioned in length to extend from a neck of the aneurysm below the renal arteries to above the coeliac artery, for anchoring the prosthesis at a location above the coeliac artery; and

the plurality of thin lines including at least six thin lines spaced about a circumference of the tube, each of the lines being sufficiently thin so as to not obstruct blood flow to the coeliac, mesenteric and renal arteries regardless of the angular orientation of the tube and the anchoring unit within the aorta.

10. The prosthesis of claim 9, wherein the anchoring unit further includes an expandable stent connected to the second ends of the lines.

11. The prosthesis of claim 9, wherein the plurality of lines are curved so that the first and second ends of the plurality of lines push, from a compressed state, radially outward so as to conform to the shape of aortic walls and to exert a pressure thereon.

12. The prosthesis of claim 11, wherein the second ends of the lines are sharp so as to embed in an aortic wall to anchor the prosthesis.

13. The prosthesis of claim 12, wherein the plurality of lines are connected together near the midsection of the plurality of lines.

14. The prosthesis of claim 11, wherein the first end of the tube is circumferentially stretchable under the radially outward pressure of the plurality of lines, so that the first end of the tube conforms to the shape of an aortic wall.

15. The prosthesis of claim 9, wherein the tube includes a collar of compressible, elastic material at the first end of the tube, wherein the collar expands radially to conform to an aortic wall.

16. The apparatus of claim 9, wherein the plurality of lines are evenly distributed about the circumference of the tube.

17. The apparatus of claim 9, wherein the plurality of lines are shaped to curve, from approximately the midsection of the plurality of lines to the first and second ends of the plurality of lines, radially outward.

18. A prosthesis for endovascular repair of aortic aneurysms, the prosthesis including:

a tube having first and second ends, to serve as a conduit for blood flow in an aneurysm of an aorta; and

an anchoring unit including a plurality of thin lines having first and second ends, the first ends of the lines being connected to the first end of the tube and the second ends of the lines being separated by a distance from the first end of the tube for anchoring the prosthesis to an aortic wall at a location away from the aneurysm, the plurality of lines being curved so that the first and second ends of the plurality of lines push, from a compressed state, radially outward so as to conform to the shape of aortic walls and to exert a pressure thereon, the second ends of the lines being sharp so as to embed in the aortic wall to anchor the prosthesis, and the plurality of lines being connected together near a midsection of the plurality of lines.

19. A prosthesis for endovascular repair of aortic aneurysms, the prosthesis including:

a tube having first and second ends, to serve as a conduit for blood flow in an aneurysm of an aorta; and

an anchoring unit including a plurality of thin lines having first and second ends, the first ends of the lines being connected to the first end of the tube and the second ends of the lines being separated by a distance from the first end of the tube for anchoring the prosthesis to an aortic wall at a location away from the aneurysm, the plurality of lines being shaped to curve, from approximately a midsection of the plurality of lines to the first and second ends of the plurality of lines, radially outward.