



US006132061A

United States Patent [19]

[11] **Patent Number:** **6,132,061**

Andrus et al.

[45] **Date of Patent:** **Oct. 17, 2000**

[54] **HALOGEN LIGHT FIXTURE**

5,624,178 4/1997 Lee, Jr. 362/220
5,676,458 10/1997 Shemitz et al. 362/374

[75] Inventors: **Don Andrus**, High Point; **Brian L. Spitler**, Elon College, both of N.C.; **Pei Sheng Qian**, Shanghai, China

OTHER PUBLICATIONS

[73] Assignee: **Regent Lighting Corporation**, Burlington, N.C.

Brochure Entitled: Model 29001 Shop Light Installation Instructions.

[21] Appl. No.: **09/177,281**

Primary Examiner—Mohammad Y. Sikder
Attorney, Agent, or Firm—Niro, Scavane, Haller & Niro

[22] Filed: **Oct. 22, 1998**

[57] ABSTRACT

Related U.S. Application Data

[60] Provisional application No. 60/086,663, Mar. 26, 1998.

A halogen light fixture that houses at least one halogen lamp and is mountable to a support surface. The fixture includes an elongated housing having opposing ends and an interior space in which the halogen light source located. The fixture is mounted to a surface by mounts that secure the fixture to the support surface. The mounts are also oppositely located on the housing and are adapted to releasably engage a plurality of locations on a surface of the housing which causes the housing to tilt in a predetermined manner thereby allowing light to be directionally positioned.

[51] **Int. Cl.**⁷ **F21V 18/00**

[52] **U.S. Cl.** **362/217; 362/218; 362/222; 362/223; 362/224; 362/225**

[58] **Field of Search** **362/217, 218, 362/222, 223, 224, 225**

[56] References Cited

U.S. PATENT DOCUMENTS

5,154,507 10/1992 Collins 362/218

4 Claims, 5 Drawing Sheets

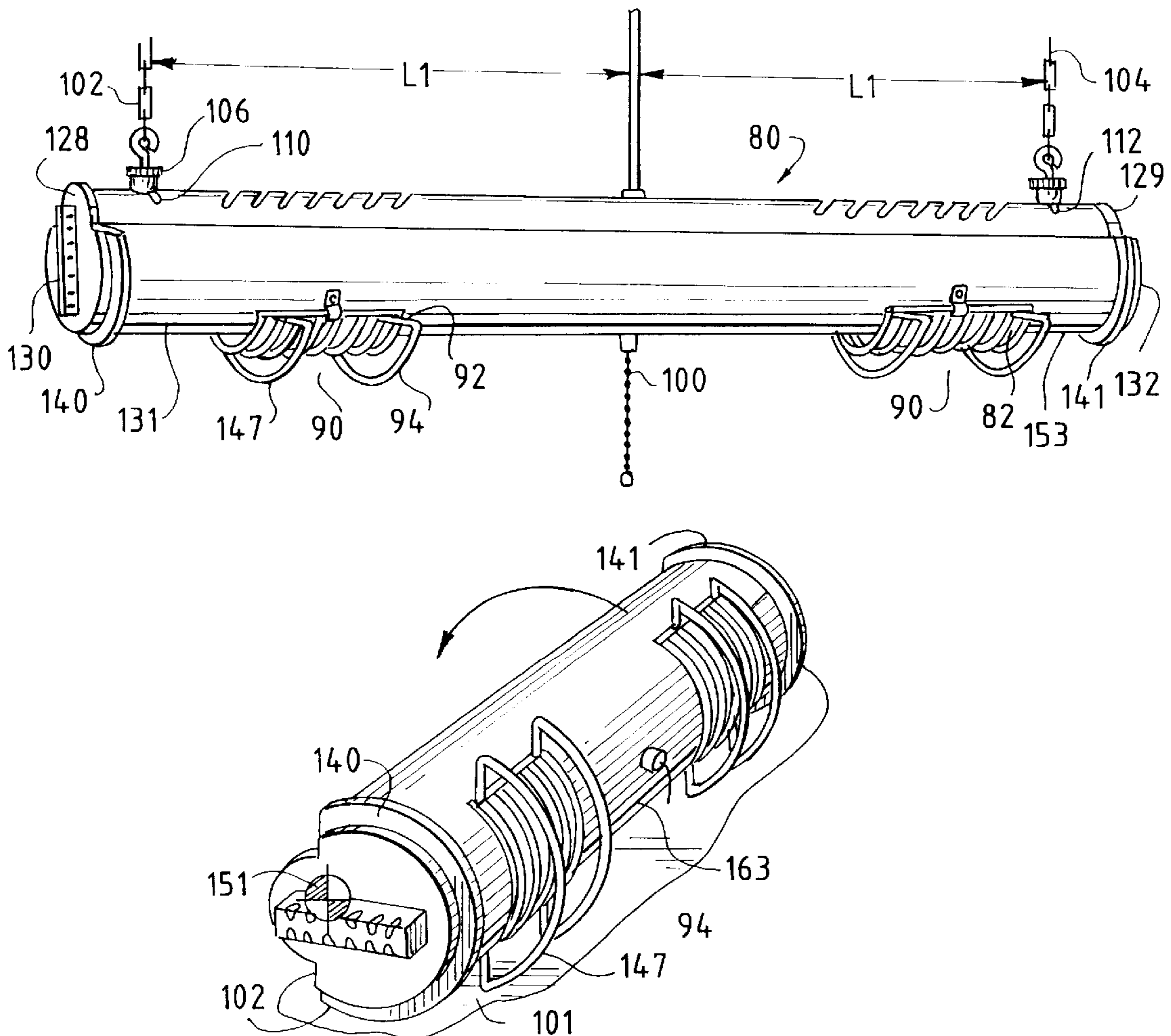

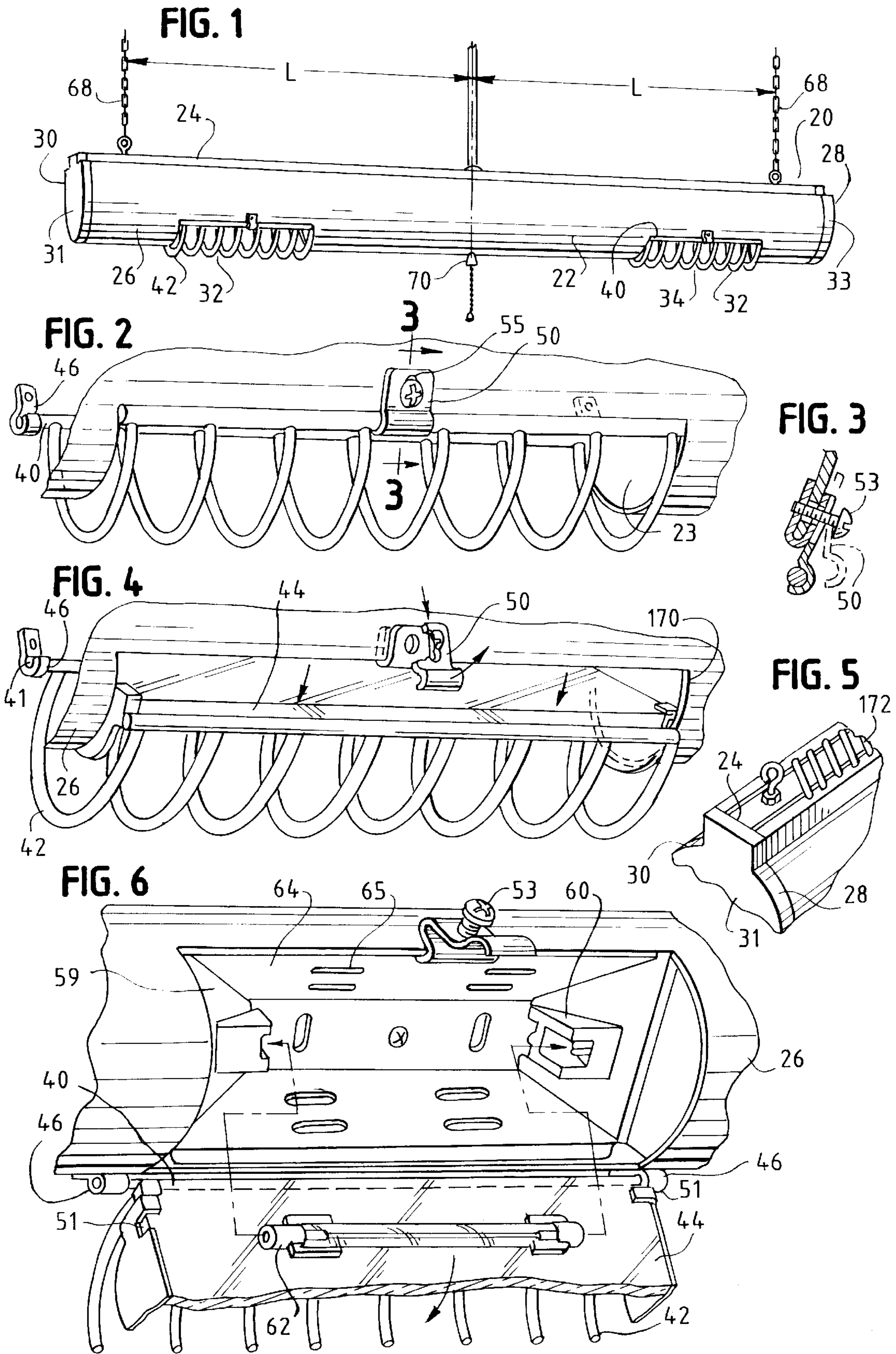

FIG. 7

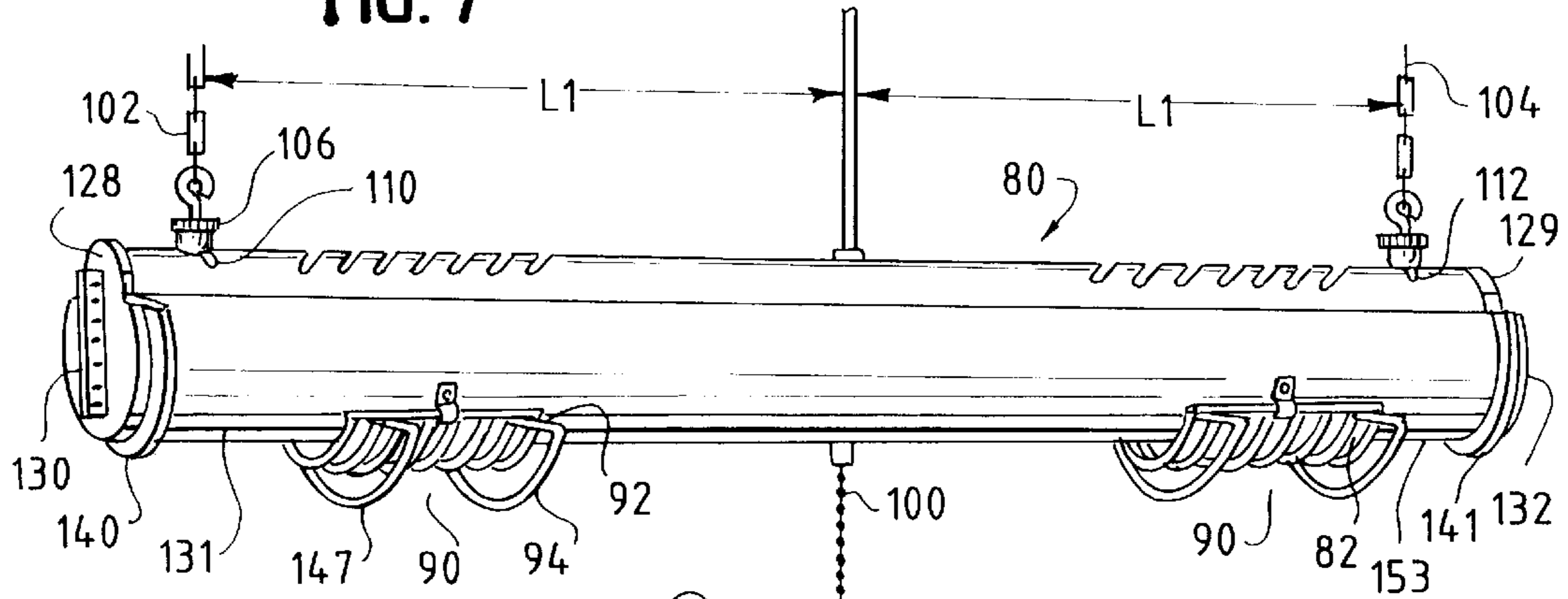

FIG. 8

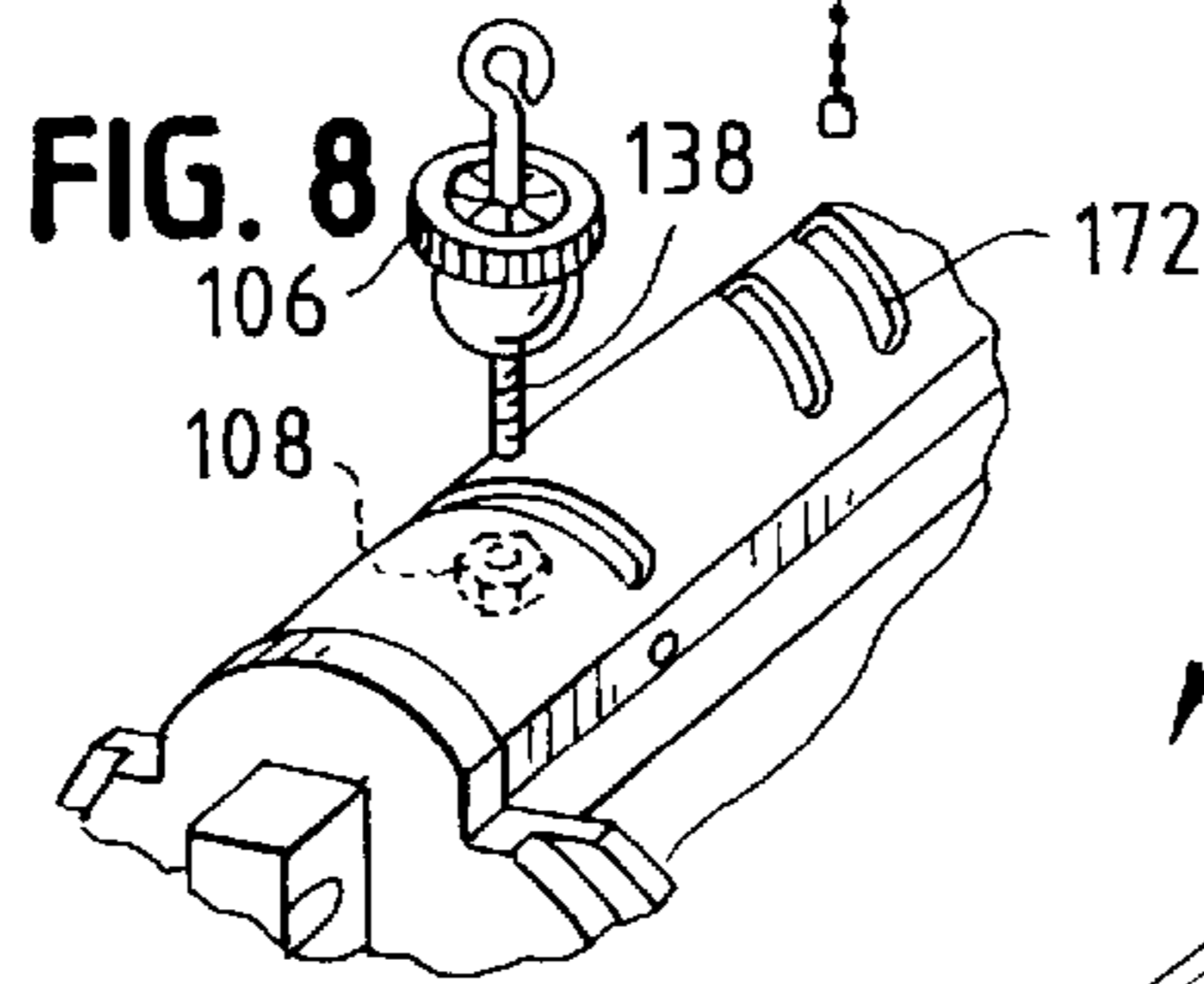

FIG. 10

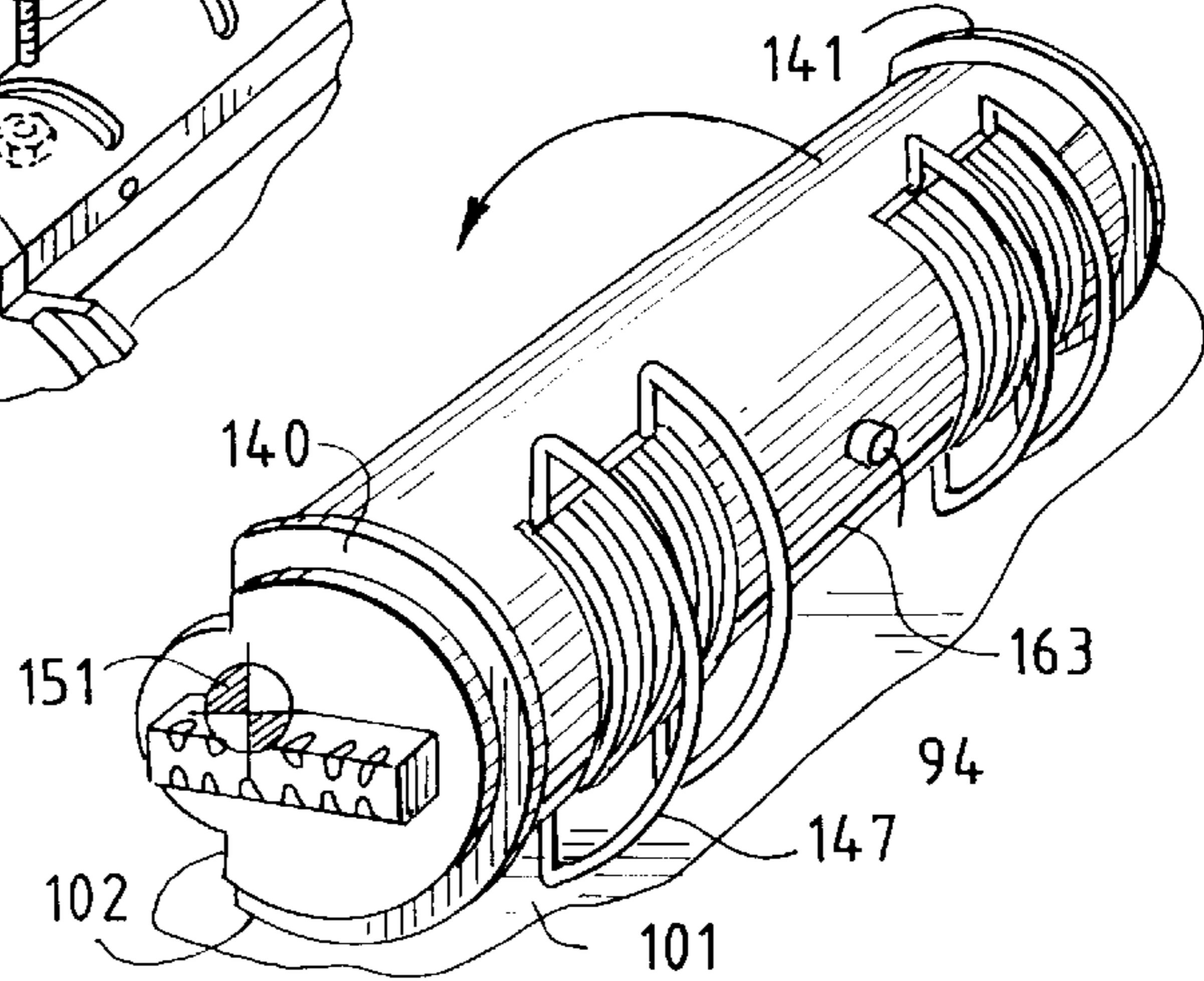

FIG. 9

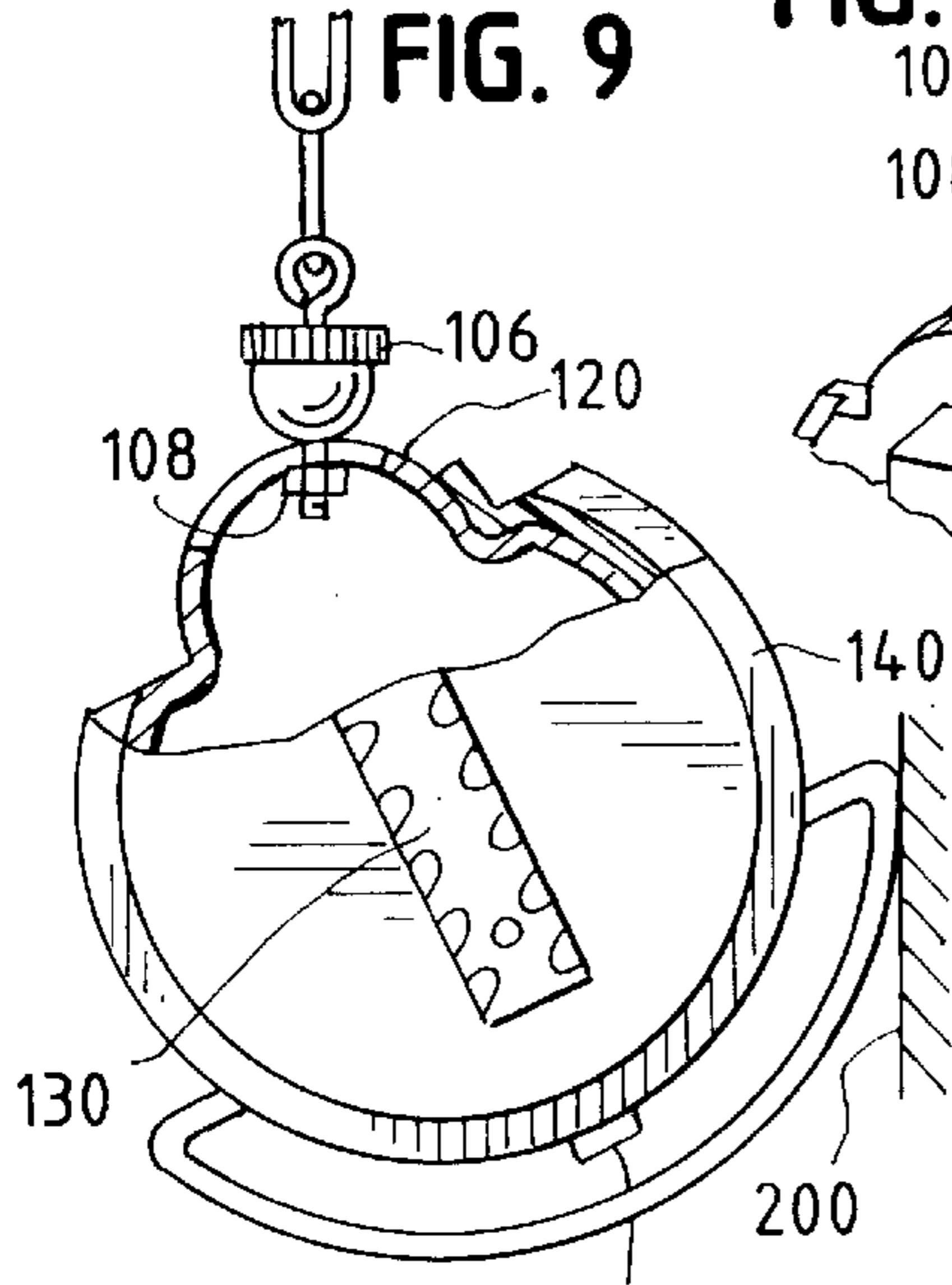

FIG. 11

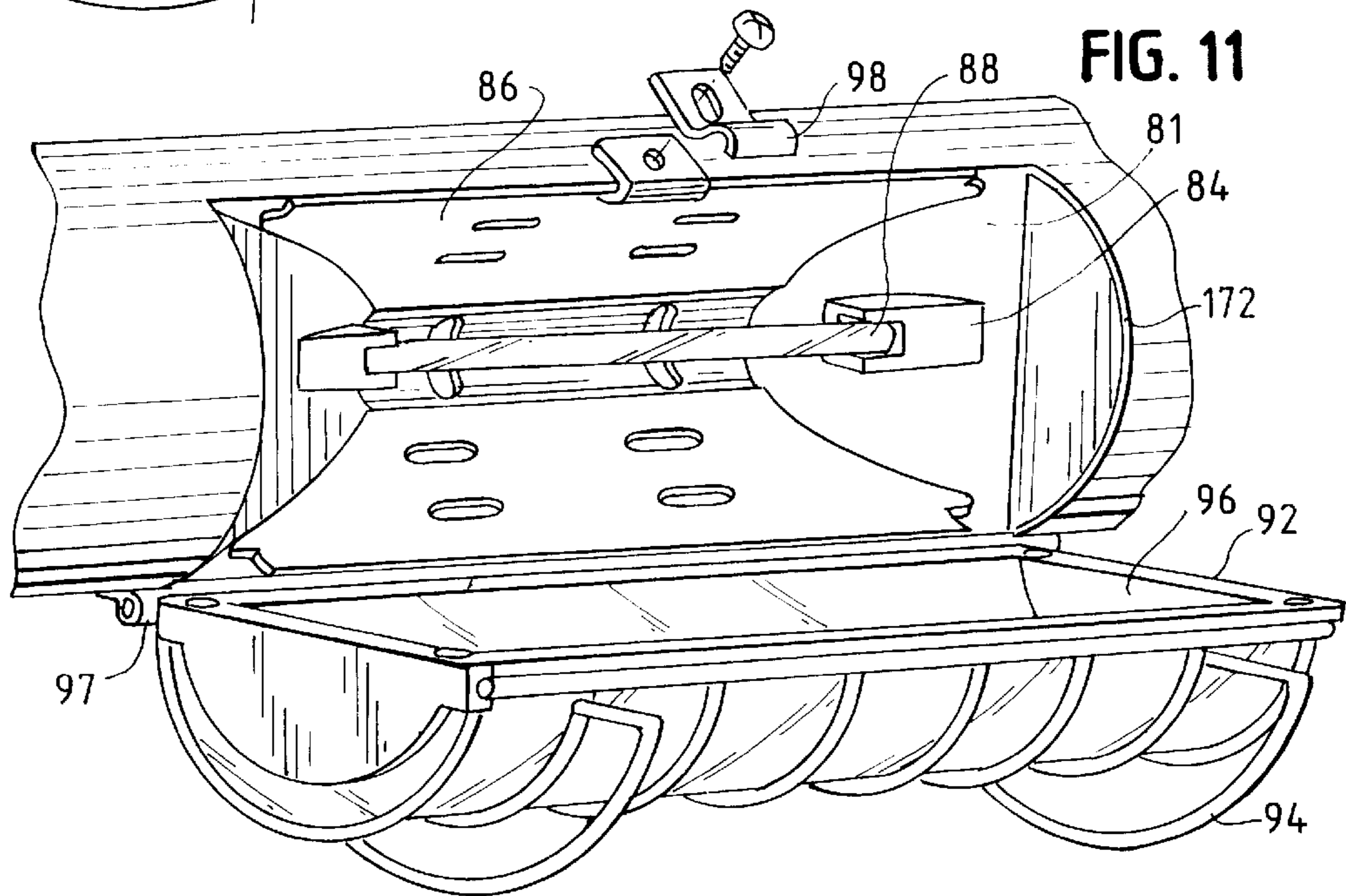

FIG. 12

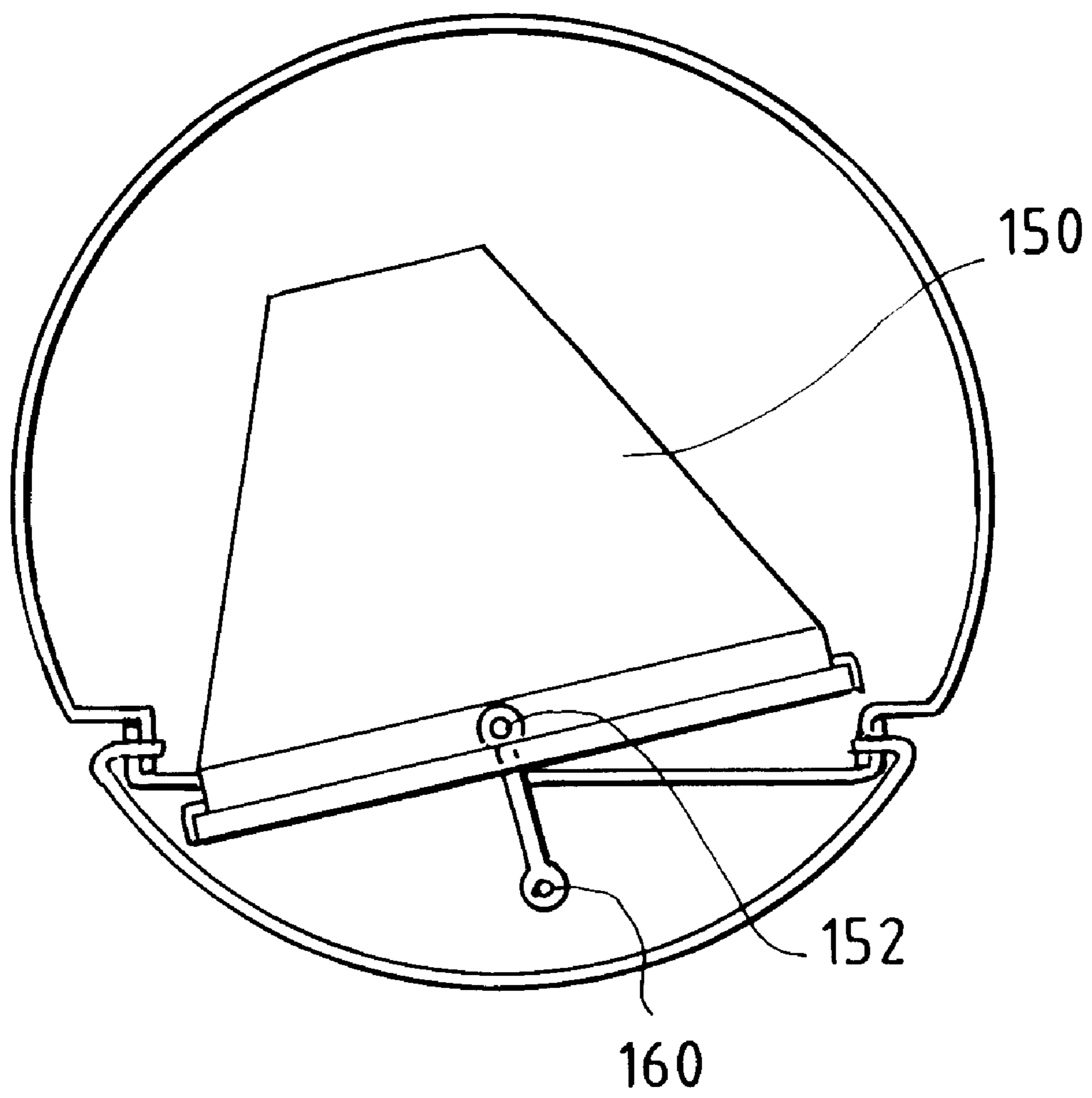

FIG. 13

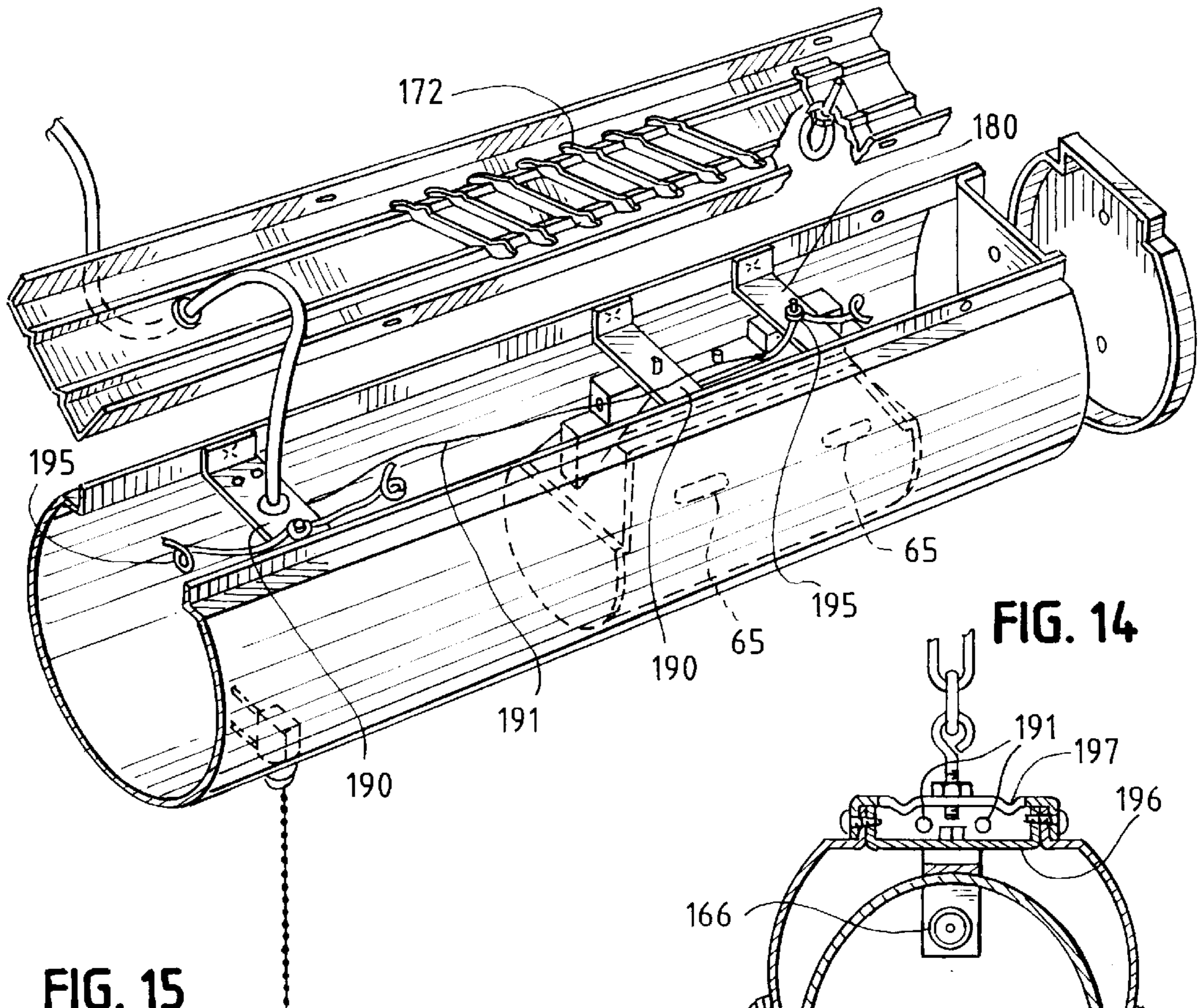

FIG. 14

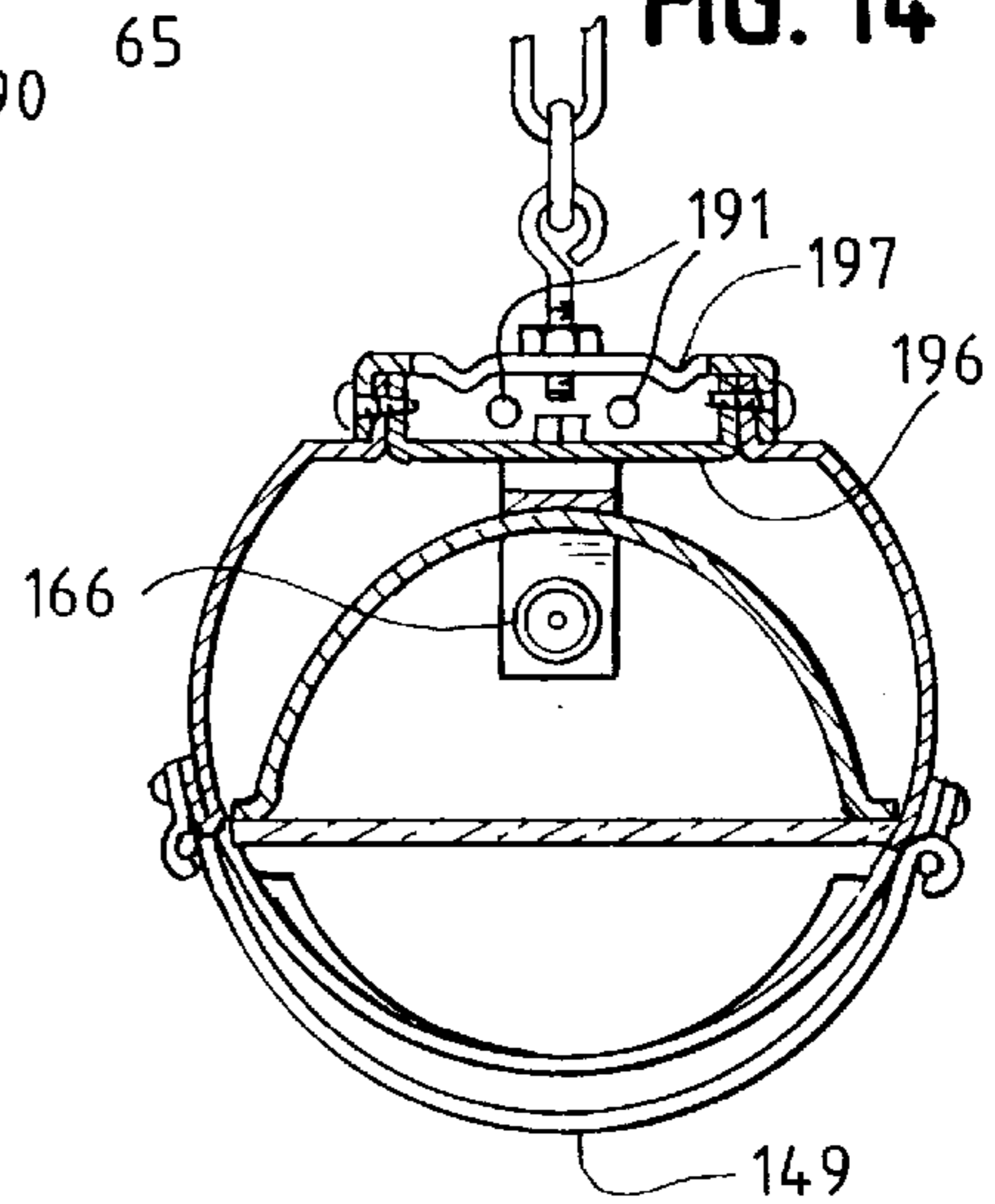

FIG. 15

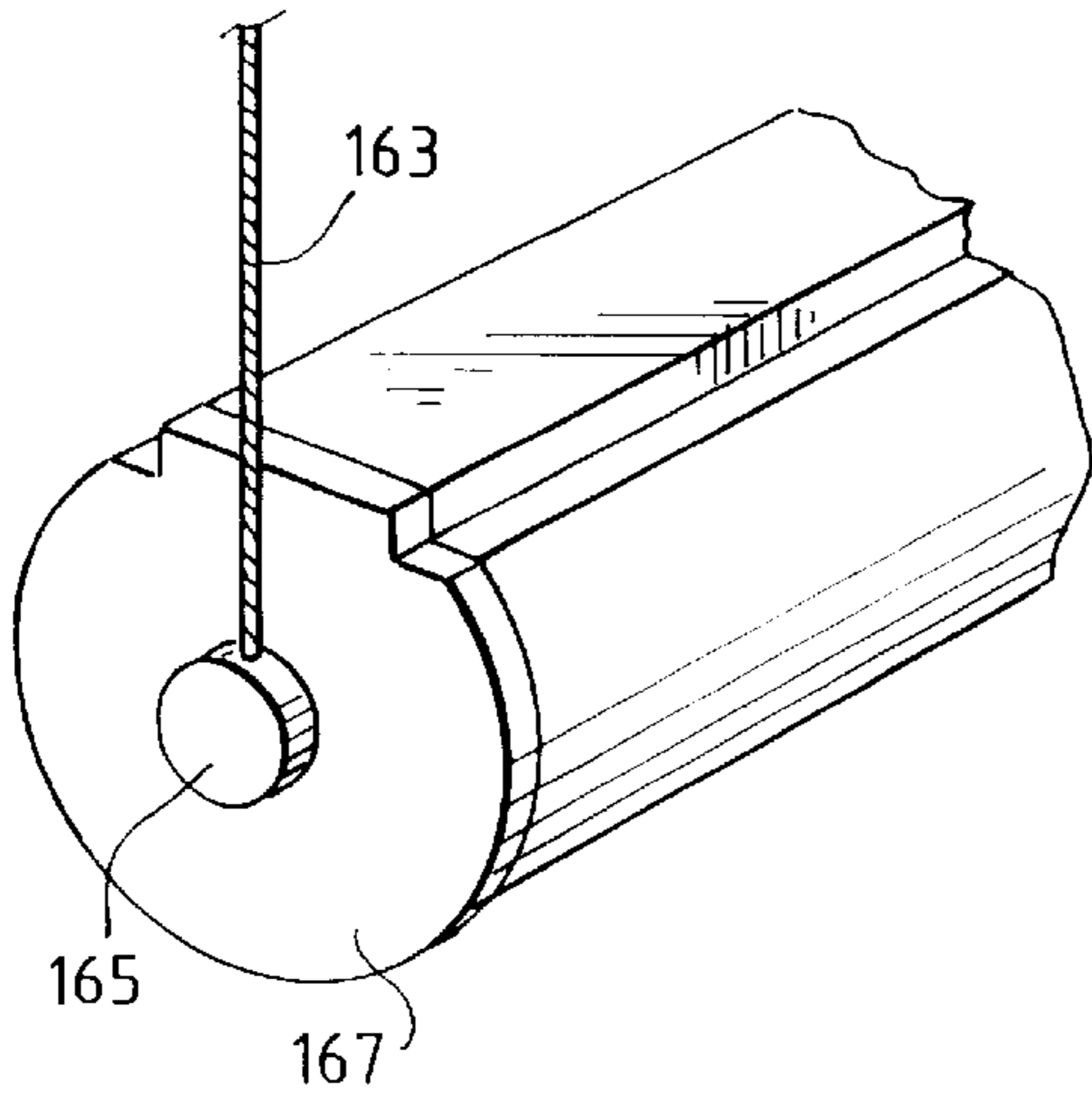

FIG. 16

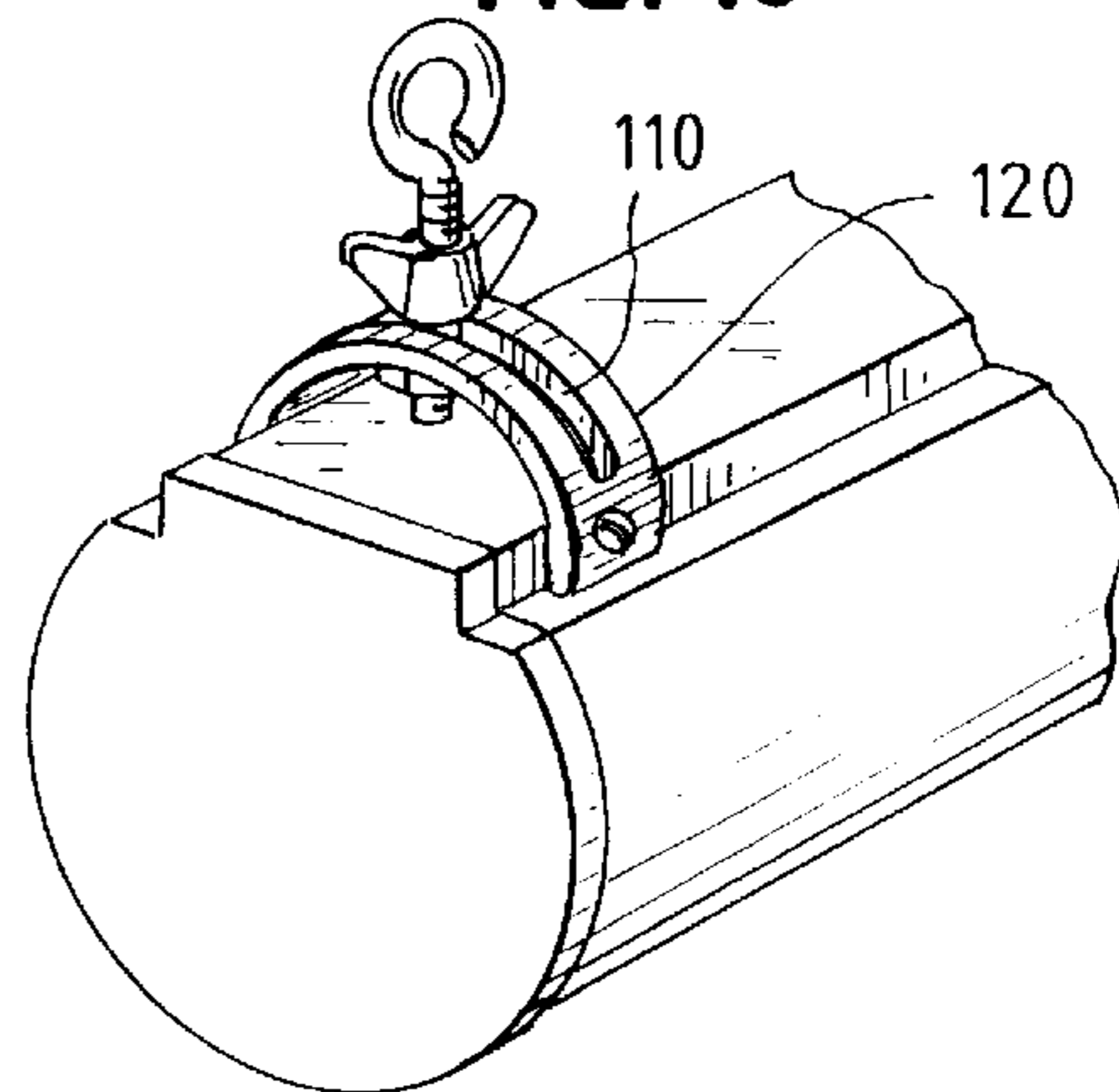

FIG. 17

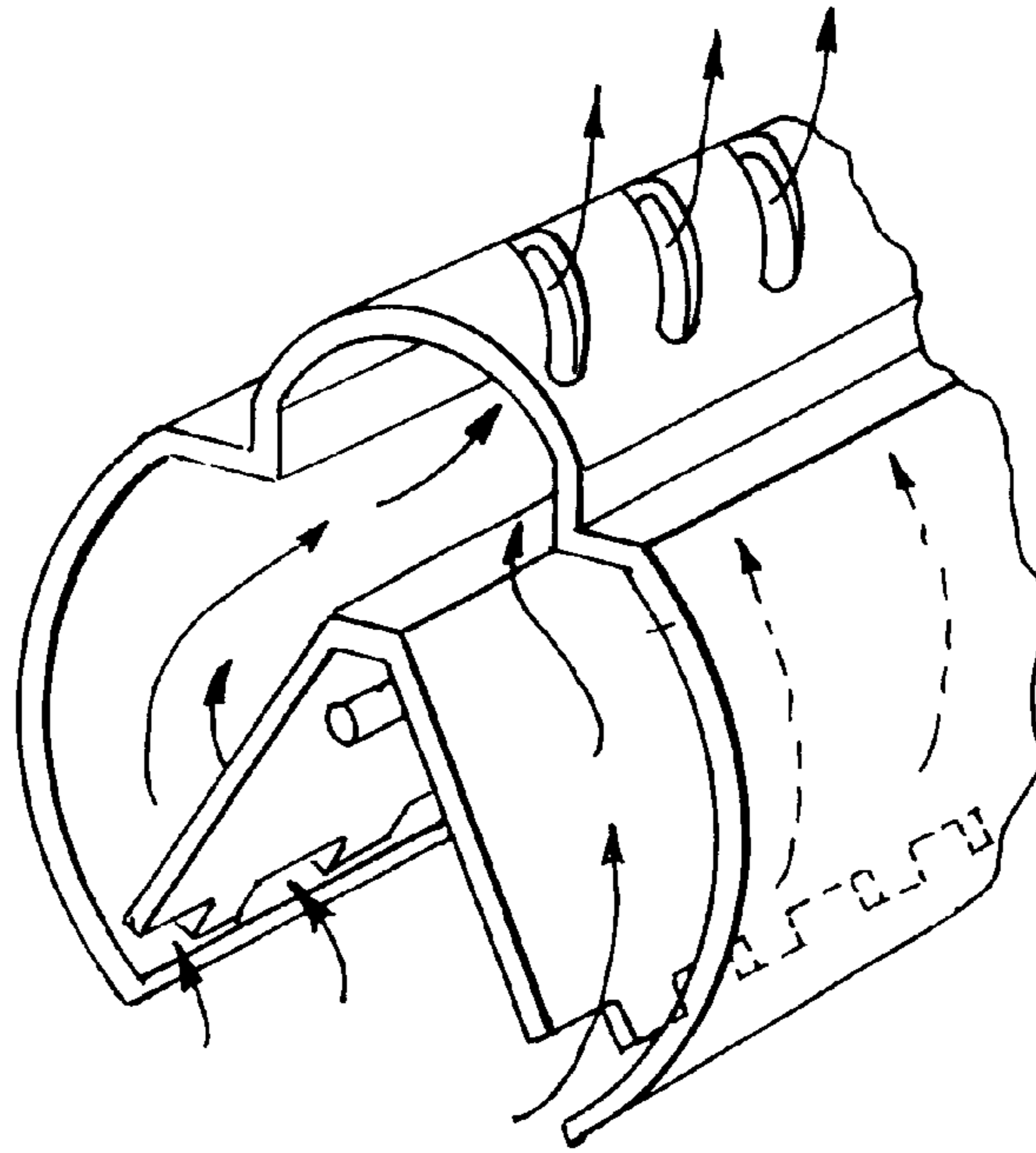
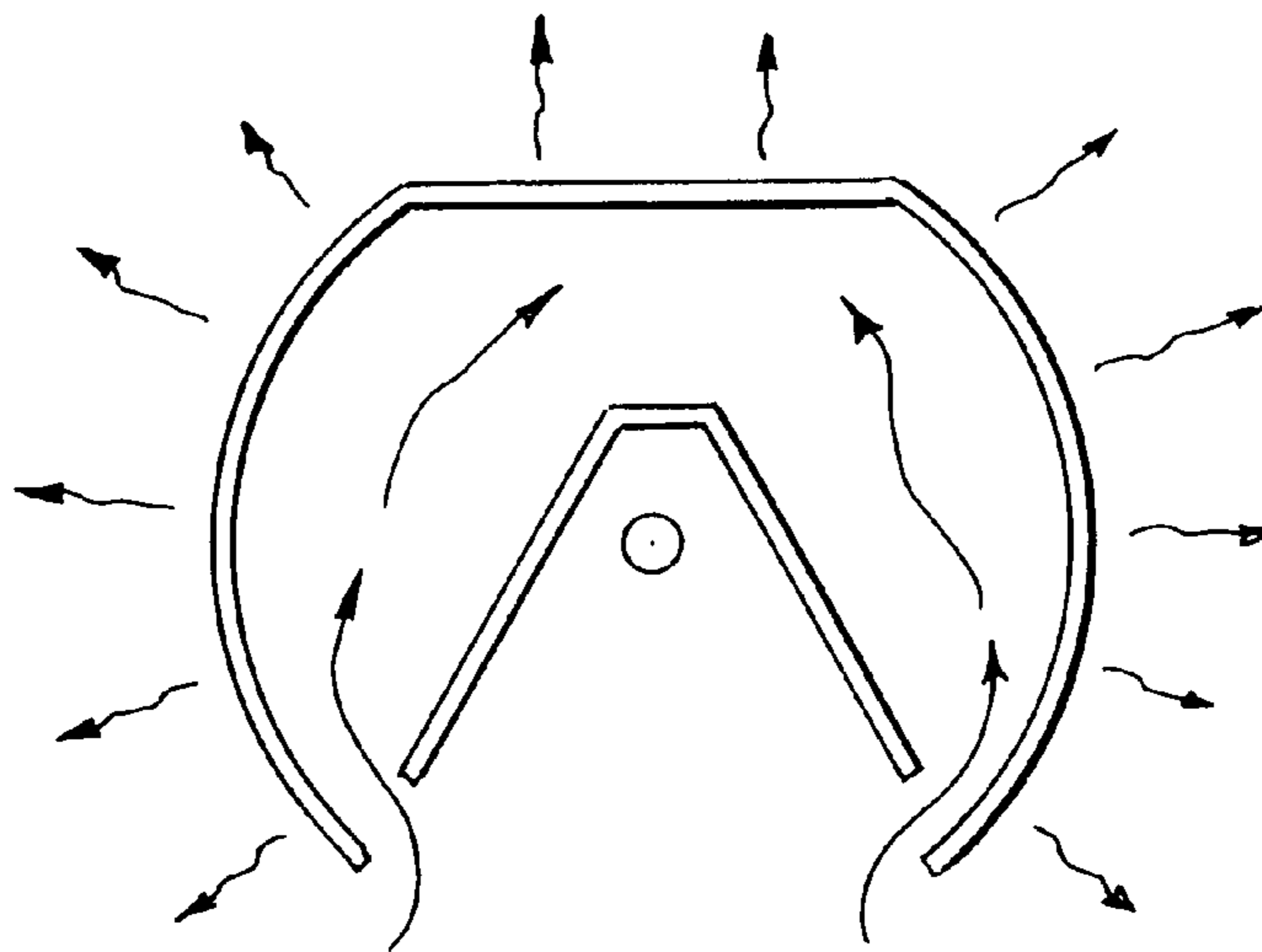

FIG. 18



HALOGEN LIGHT FIXTURE

This application claims priority to pending Provisional Patent Application Serial No. 60/086,663 which was filed on May 26, 1998.

BACKGROUND OF THE INVENTION

The use of halogen lamps in light fixtures provides many advantages over the use of fluorescent and incandescent lamps. Halogen light sources provide, among other benefits, pure white light, instant start-up with no flickering, and are operational at any temperature including sub freezing temperatures.

However, halogen light fixtures typically employ one or more lamps having a wattage that is often 100 watts or greater. This use of high wattage lamps increases the heat generated in and around the fixture. Thus, there is a need for light fixtures that allow and provide for the efficient dissipation of the heat generated by the lamp or lamps contained therein. Not only will the dissipation of heat prevent the fixture itself from becoming dangerously hot, it also assists in protecting the fixture's internal components from heat damage as well.

In addition, because of the high temperatures created by a halogen lamp, the possibility exists that objects located near the lamp may unintentionally combust. Consequently, there is a need for a fixture design that prevents objects or structures such as walls and the like from coming into close contact with the light generated by the fixture in order to reduce the risk of inadvertent combustion.

SUMMARY OF THE INVENTION

The present invention, therefore, is directed to a light fixture that houses halogen lamps, and more particularly, a light fixture that is safer to use than light fixtures currently in use. The invention promotes safer operation of halogen lamps by placing the lamp in a tubular fixture having oppositely located vents that use convective air flow to efficiently dissipate heat from the fixture. Moreover, by placing the halogen source in a central location within the fixture, heat is more efficiently radiated outwardly by the walls of the fixture.

In addition, the weight distribution of the fixture is such that when placed upon a flat surface, the fixture will roll in such a manner to direct light away from the surface so as to prevent combustion. Moreover, the present invention uses outwardly adjacent guards that also prevent the combustion of vertical surfaces that may be in close proximity to the lamp.

BRIEF DESCRIPTION OF THE DRAWINGS

The novel features which are characteristic of the present invention are set forth in the appended claims. The invention itself, however, together with further objects and attendant advantages, will be best understood by reference to the following description taken in connection with the accompanying drawings in which:

FIG. 1 is a perspective view of one embodiment of the invention;

FIG. 2 illustrates the frame in a closed position;

FIG. 3 is a side view of the latch used on the embodiment shown in FIG. 1;

FIG. 4 illustrates the frame in a partially open position;

FIG. 5 is a partial perspective view of the upper portion of the embodiment shown in FIG. 1;

FIG. 6 illustrates the frame in a fully open position;

FIG. 7 is a perspective view of another embodiment of the invention;

FIG. 8 is a partial perspective view of the upper portion of the embodiment shown in FIG. 7;

FIG. 9 is a side view of the embodiment shown in FIG. 7;

FIG. 10 illustrates how the device rolls over when at rest on a surface;

FIG. 11 illustrates the frame in a fully open position;

FIG. 12 is a side view of another embodiment of the invention;

FIG. 13 is a perspective view of another embodiment of the invention;

FIG. 14 is a cross sectional view of the embodiment shown in FIG. 13;

FIG. 15 is a partial perspective view illustrating an adjustment mechanism;

FIG. 16 is a partial perspective view of yet another adjustment mechanism;

FIG. 17 is a side view which illustrates convective air flow within an embodiment of the invention; and

FIG. 18 is another side view which illustrates how heat is evenly dissipated by another embodiment of the present invention.

DETAILED DESCRIPTION OF THE PREFERRED EMBODIMENTS

As shown in FIG. 1, the present invention provides a halogen light fixture 20 having an elongated housing 22 including an upper section 24, a lower section 26, and sidewalls 28 and 30 which may be made of stamped metal or some other material known to those of skill in the art. As shown in FIG. 2, housing 22 also defines an interior space 23, which is enclosed by oppositely located ends 31 and 33 which may be made of plastic and affixed to housing 20 by fasteners and the like.

Also located on housing 22 are apertures 32 and 34 through which light is transmitted and which are covered by a frame 40 which may include an outwardly extending grill 42 and lens 44. As shown in FIGS. 2-4, frame 40 may be of a welded wire construction or some other suitable construction and pivotally mounted to housing 20 by securing ends 41 of the frame to housing 20 through the use of clips 46. FIG. 3 depicts latch 50 which is also affixed to housing 22 and releasably retains frame 40 in a closed position as shown in FIG. 2, and when disconnected from the frame, frame 40 is in an open position as shown in FIG. 6.

The outer edges of frame 40 may be coextensive with lens 44 and lens 44 is secured to frame 40 through the use of clips 51 which are oppositely located on frame 40. Securing lens 44 and grill 42 to frame 40 allows ease of access to lamp 62. As described above, when latch 50 is disengaged and frame 40 is in an open position, both the grill and lens are placed into a position in which they no longer cover aperture 23. This, in turn, allows a user to directly access the lamp without having to remove the grill and lens in separate, time consuming, operations.

To operate latch 50, fastener 53 is loosened and through the use of slot 55, latch 50 is allowed to move away from frame 40. This permits disengagement and the process is reversed when it is desired to place frame 40 in a closed position.

As shown in FIG. 6, a light source 59 is aligned with the apertures and located within interior space 23. Light source

59 includes a lamp socket **60** which holds halogen lamp **62** in place and also provides an electrical connection to an electrical source. Also included is reflector **64**, having vents **65**, which directs light generated by lamp **62** outwardly through the aperture and the lens.

Since halogen light fixtures are generally suspended from a surface such as ceiling, mounts such as chains **66** and **68**, as shown in FIG. 1, are provided. To assist users in activating the fixture, a pull switch **70** is also provided. In addition, as shown in FIG. 1, switch **70** may be located in the center of housing **22** and chains **66** and **68** may be located an equal distance from the switch. Configuring the device in this manner balances the device so that when the switch is employed, it reduces, if not eliminates, the sway typically associated with the use of a pull switch on overhead light fixtures.

As shown in FIGS. 7–11, light fixture **80** may be adapted to include an adjustability fixture that permits a user to aim the light in a desired direction. As shown, elongated housing **80** defines an interior space **82** which houses at least one light source **81** comprised of a light socket **84**, reflector **86**, and halogen lamp **88**. As was also described previously, housing **80** includes at least one aperture **90** which is aligned with the light source and which is covered by a frame **92** having affixed thereto a grill **94** and lens **96**.

As described above, frame **92** is pivotally connected to housing **80** in the same manner described above through the use of clips **97** and latch **98**. As was also described above, a pull switch **100** and chains **102** and **104** are arranged in the same manner described above to prevent the fixture from swaying when the pull switch is used.

To provide an adjustment feature, coacting fasteners **106** and **108** are positioned at one end of chains **102** and **104** and into slots **110** and **112** on surface **120**, which may be part of housing **80** or a separate plate which is attached to housing **80** as shown in FIG. 15. As shown in FIG. 10, using coacting fasteners which releasably engage surface **120**, allows the chains to be located on a plurality of positions along housing **80**. This, in turn, causes the fixture to tilt and thus adjusts the angle in which light is directed from the fixture. As also shown, in a preferred embodiment, surface **120** may be curved although it need not be so long as the locations in which the mounts engage the housing may be changed.

To adjust the light in a preferred embodiment, the fasteners are first loosened and handles **130** and **132**, located on end-caps **128** and **129**, are employed to rotate the fixture allowing a shank **138** of fastener **106** to change position on the housing and within the slot located on the curved surface. Once in a desired position, the fasteners are re-tightened to securely engage the housing.

Alternatively, as shown in FIG. 12, the light source may be pivotally connected to the housing inside the interior space. As shown, light source **150** is pivotally connected to the housing by oppositely located pins **152** that engage opposite ends of the light source or by other means that form an axis upon which the light source may be pivoted. To assist in positioning the light, a handle **160** may be provided as shown in FIG. 9.

As shown in FIGS. 14 and 15, the mount **163** may be pivotally connected to the housing by coacting fasteners **165** and **166** at the end cap **167**. Again, arranging the fixture in this manner also allows the fixture to be adjustably positioned.

However, as mentioned above, as a result of the high wattage lamps used in the fixtures of the present invention, there exists the possibility that the light may be adjusted in

a manner in which light is directed toward a wall **200** as shown in FIG. 10. In this situation, the heat emitted by the lamp may cause the combustion of the surface. To prevent combustion from occurring, flanges **140** and **141** may be used as guards or projections that hold the fixture away from an object. As shown, flanges **140** and **141** may be located on the end-caps and extend outwardly from housing **80**. Flanges **140** and **141** should be sized to extend outwardly a sufficient distance to prevent combustion of the surface, even when the light has been fully positioned inwardly at the object. The flanges may extend outwardly about $\frac{1}{4}$ to $\frac{3}{4}$ inches away from the housing.

Alternatively, a grill **145** having one or more sections **147** which extend outwardly beyond the walls of housing may be used. As with the flanges, grill sections **147** should be sized to prevent combustion of the surface even when the light is in its most inwardly directed position. Grill sections **147** may extend about $\frac{1}{2}$ inch to 2 inches past the housing.

Another problem associated with the use of high wattage halogen lamps is that the fixture may come to rest upon a flat surface such as a box or floor while the lamps are activated, a condition which may result in the combustion of the surface. To prevent this from occurring, the fixture is adapted to roll on its side **102** and redirect the light away from the surface.

One manner in which this may be accomplished is to locate the center of mass of the light **151** above the fixture's center line. Locating the weight of the fixture in this manner causes the light to tip or roll over when placed on a flat surface.

Alternatively, a protrusion such as switch **100** may be sized to extend downwardly a sufficient distance to contact the surface to cause the entire fixture to tip over about the protrusion. Alternatively, grill **147** may include points **149** which also cause the fixture to roll as shown in FIG. 14.

Another concern associated with the use of halogen lamps is the efficient dissipation of the heat generated and the cooling of the fixture. As mentioned above, the use of high wattage lamps generates temperatures in excess of those typically associated with fluorescent lamps and the like. The high temperatures, if not dissipated, may damage the housing, the internal components of the fixture and, as importantly, present a safety concern.

To efficiently cool the fixture, the light fixture of the present invention uses convection to cool the fixture. As shown in FIG. 17, the present invention provides air intakes **170** which may be gaps between the lens and the housing, and exhaust vents **172** which are oppositely located. In operation, as the air inside interior space is heated, it rises up and is funneled by the sidewalls **180**, which taper inwardly, up into and out of the exhaust vents. As the air rises, cool air is drawn into and around the light source **185** by the walls of the fixture.

To optimize the cooling effect of the air flow without creating stagnant or dead air spaces, it has been found that efficient cooling is obtained by having air flow up and around the lamp and then having the sidewalls taper inwardly to funnel the heated air out of the fixture. To further assist in eliminating stagnant or dead air zones that may be created, the sidewalls may terminate co-extensively with or adjacent to the exhaust vents. Arranging the sidewalls in this manner creates air flow paths in which no disruptive countercurrents or eddies are produced which may restrict air flow. Suitable wall configurations include, but are not limited to, curved and/or arcuate walls which produce complementary air flow paths. As referenced above, walls which taper inwardly are suitable as well.

It has been found that walls of the configuration described above, help eliminate dead air zones or stagnant air pockets in the fixture and it also keeps the air in close proximity to the lamp so as to surround the lamp with cooling air movement, which may not be accomplished with box-like configurations.

Another method by which efficient cooling may be achieved is by locating the lamp substantially in the center of a housing, which may be tubular in construction, in which the lamp is approximately an equal distance from the walls of the housing. Configuring the device in this manner allows the walls of the fixture to be evenly heated and to evenly radiate the energy absorbed. This, too, assists in preventing the device from becoming excessively hot.

Another hazard associated with the use of high temperature halogen lamps is potential damage to the internal wiring due to excessive temperatures. If the wiring is damaged, not only may the device be rendered inoperable, it may also present an electrical hazard. This is of particular concern in the event the wiring comes into contact with the light source.

To prevent this from occurring, the present invention uses one or more wireways **190** which securely position wiring **191** above the light source. As shown in FIGS. **13** and **14**, in a preferred embodiment, wireways **190** are located above the light source and bridge between the sidewalls of the housing. Not only does this provide structure which prevents the wiring from coming into contact with the light source, it shields the wiring as well. Moreover, by bridging between the sidewalls, additional strength is added to the fixture.

Clips **195** may also be used to retain the wiring as well. Lastly, the wireway may be comprised of a first section **196** and second section **197** which form a channel in which the wiring is safely enclosed.

In addition, because vents are used on both the housing and reflector, another hazardous condition may be created when vents **65** and **172** are aligned to permit an electrically conductive device, such as a screwdriver, to be inserted into the device and into contact with the halogen light source. To prevent this from occurring, vents **65** should be aligned in

such a manner as to prevent direct access to the light source as shown in FIG. **14**. Alternatively, as also shown, wireway **190** may be positioned over vents **65** to act as a shield that prevents access to the halogen light source as well.

It should be understood that various changes and modifications to the preferred embodiment described would be apparent to those skilled in the art. Changes and modifications can be made without departing from the spirit and scope of the present invention and without diminishing its intended advantages. It is, therefore, intended that such changes and modifications be covered by the following claims.

What is claimed is:

1. A light fixture comprising:

a housing having opposing ends, said housing defining an interior space and upper, lower and side sections and having at least one concave portion upon which said light fixture rolls on a surface;

at least one halogen light source located within said housing;

at least one aperture located on said lower portion of said housing, said aperture in alignment with said light source to allow light to be transmitted outwardly from the housing; and

a center of mass defined by at least said light source and said housing, said center of mass is above a center line defined by said housing so that said light fixture rolls upon said concave portion after contacting said surface so as to redirect said transmitted light away from said surface to prevent the combustion of said surface by said outwardly transmitted light.

2. The device of claim **1** further including a protrusion which assists in rolling said light fixture over.

3. The device of claim **1** wherein said concave portion is located on a grill.

4. The device of claim **1** wherein said housing is an elongated tubular housing.

* * * * *