



US006113604A

United States Patent [19]

[11] Patent Number: **6,113,604**

Whittaker et al.

[45] Date of Patent: **Sep. 5, 2000**

[54] **METHOD AND APPARATUS FOR FIXING A GRAFT IN A BONE TUNNEL**

[75] Inventors: **Gregory R. Whittaker**, Stoneham; **Harold M. Martins**, Newton; **Joan M. Sullivan**, Hanover; **Ronald L. Taylor, Jr.**, Everett, all of Mass.

[73] Assignee: **Ethicon, Inc.**, Somerville, N.J.

[21] Appl. No.: **09/014,937**

[22] Filed: **Jan. 28, 1998**

Related U.S. Application Data

[63] Continuation-in-part of application No. 08/783,627, Jan. 14, 1997, Pat. No. 5,849,013.

[51] Int. Cl.⁷ **A61B 17/56**

[52] U.S. Cl. **606/72; 606/80; 606/96; 604/164; 604/165; 604/166; 623/13**

[58] Field of Search **623/13; 606/72, 606/79, 86, 96, 185, 80, 184; 604/264, 164-166**

[56] References Cited

U.S. PATENT DOCUMENTS

| | | | |
|-----------|---------|----------------------|-----------|
| 3,973,277 | 8/1976 | Semple et al. | 3/1 |
| 4,858,603 | 8/1989 | Clemow et al. | 128/92 ZW |
| 4,901,711 | 2/1990 | Goble et al. | 606/98 |
| 4,944,742 | 7/1990 | Clemow et al. | 606/59 |
| 4,985,032 | 1/1991 | Goble | 606/96 |
| 5,004,474 | 4/1991 | Fronk et al. | 623/13 |
| 5,067,962 | 11/1991 | Campbell et al. | 623/13 |
| 5,147,362 | 9/1992 | Goble | 606/72 |

| | | | |
|-----------|---------|-------------------------|---------|
| 5,152,764 | 10/1992 | Goble | 606/96 |
| 5,234,434 | 8/1993 | Goble et al. | 606/96 |
| 5,266,075 | 11/1993 | Clark et al. | 623/15 |
| 5,350,380 | 9/1994 | Goble et al. | 606/80 |
| 5,354,300 | 10/1994 | Goble et al. | 606/80 |
| 5,356,413 | 10/1994 | Martins et al. | 606/75 |
| 5,356,435 | 10/1994 | Thein | 623/15 |
| 5,364,400 | 11/1994 | Rego, Jr. et al. | 606/72 |
| 5,372,599 | 12/1994 | Martins | 606/75 |
| 5,376,119 | 12/1994 | Zimmermann et al. | 673/13 |
| 5,393,302 | 2/1995 | Clark et al. | 623/13 |
| 5,397,356 | 3/1995 | Goble et al. | 623/13 |
| 5,431,651 | 7/1995 | Goble | 606/73 |
| 5,470,334 | 11/1995 | Ross et al. | 606/72 |
| 5,522,817 | 6/1996 | Sander et al. | 606/72 |
| 5,672,158 | 9/1997 | Okada et al. | 604/164 |
| 5,688,284 | 11/1997 | Chervitz et al. | 606/96 |
| 5,697,933 | 12/1997 | Gundlapalli et al. | 606/96 |
| 5,849,013 | 12/1998 | Whittaker et al. | 606/72 |

Primary Examiner—Michael J. Milano
Assistant Examiner—Choon P. Koh
Attorney, Agent, or Firm—Pandiscio & Pandiscio

[57] ABSTRACT

A method for fixing a bone block in a bone tunnel comprising the steps of placing the bone block in the bone tunnel, advancing spaced-apart first and second metal wires through the bone, transversely of the bone tunnel, so as to intersect the bone block and extend through the bone block, removing one of the wires and replacing the one removed wire with a first absorbable rod, and removing the other of the wires and replacing the other removed wire with a second absorbable rod, whereby to retain the bone block in the bone tunnel with the absorbable rods.

15 Claims, 48 Drawing Sheets

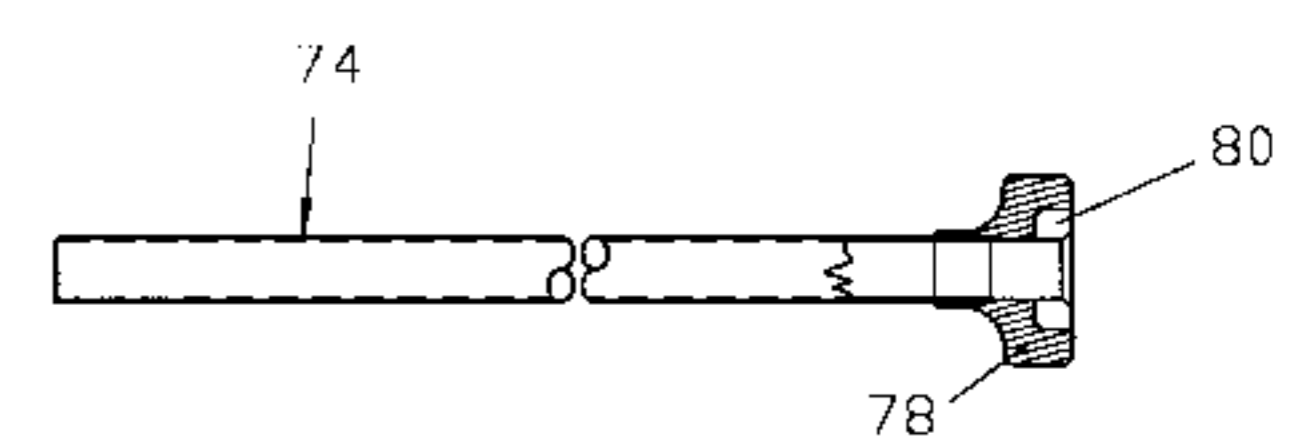
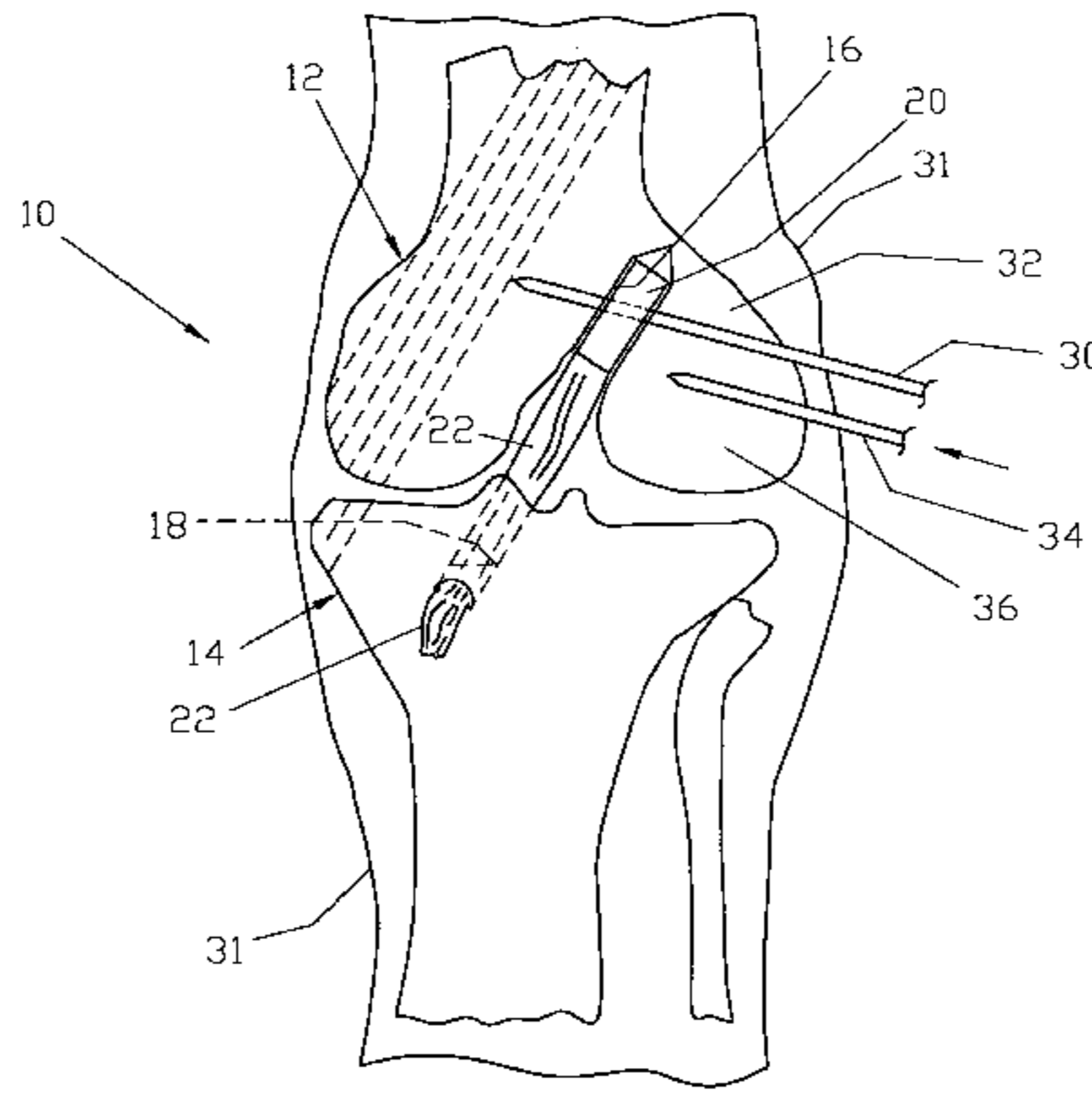
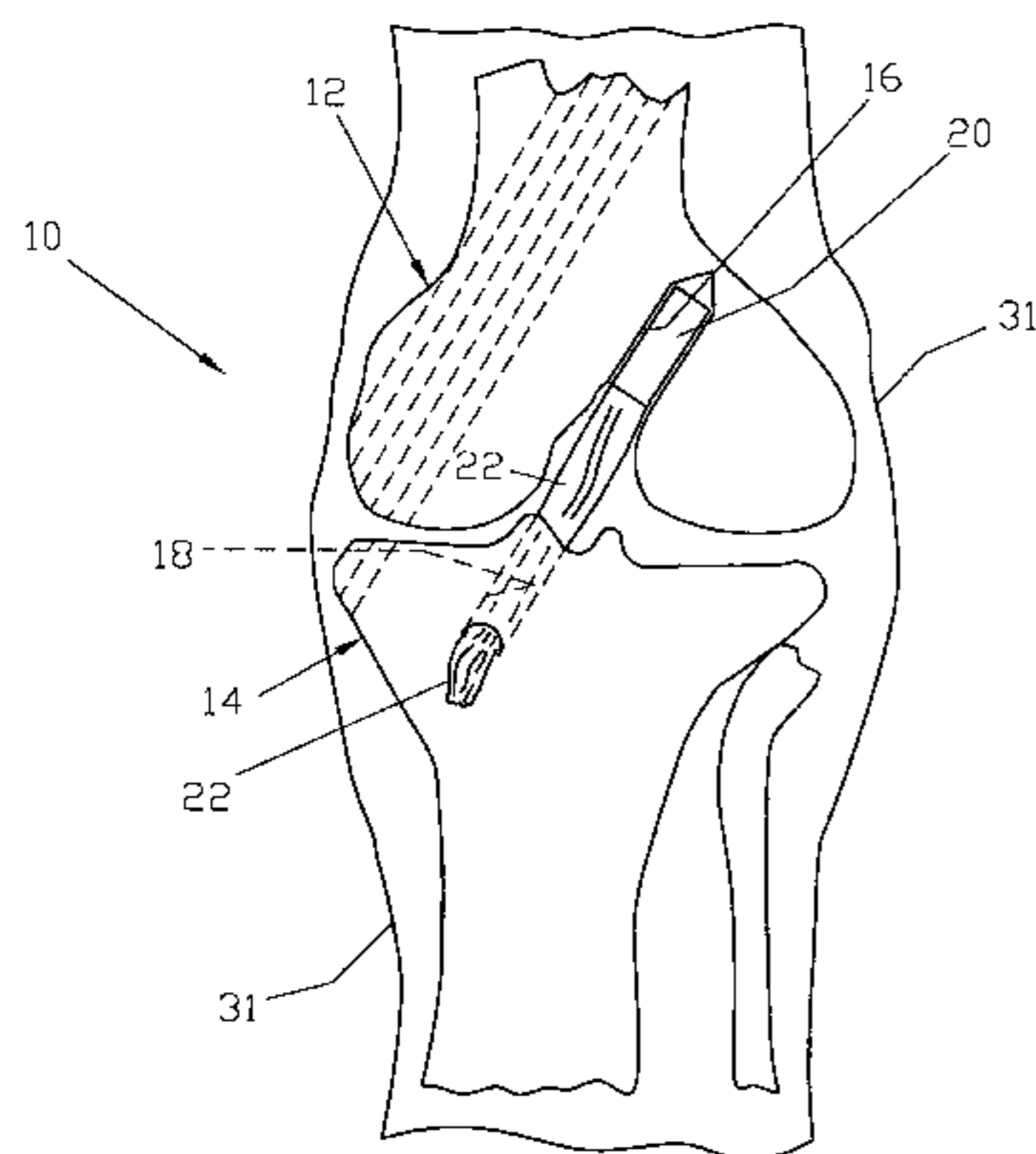

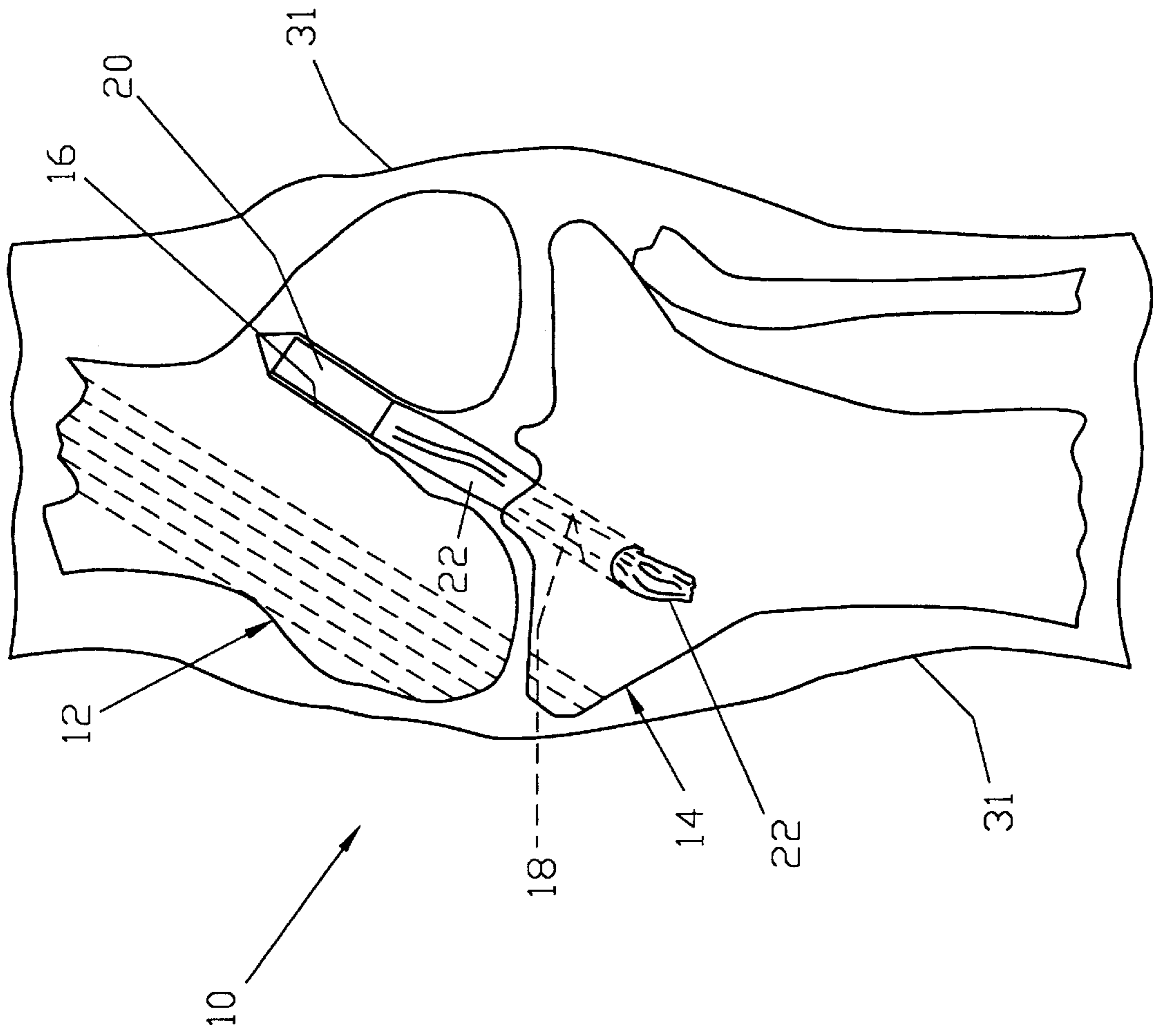

FIG. 1

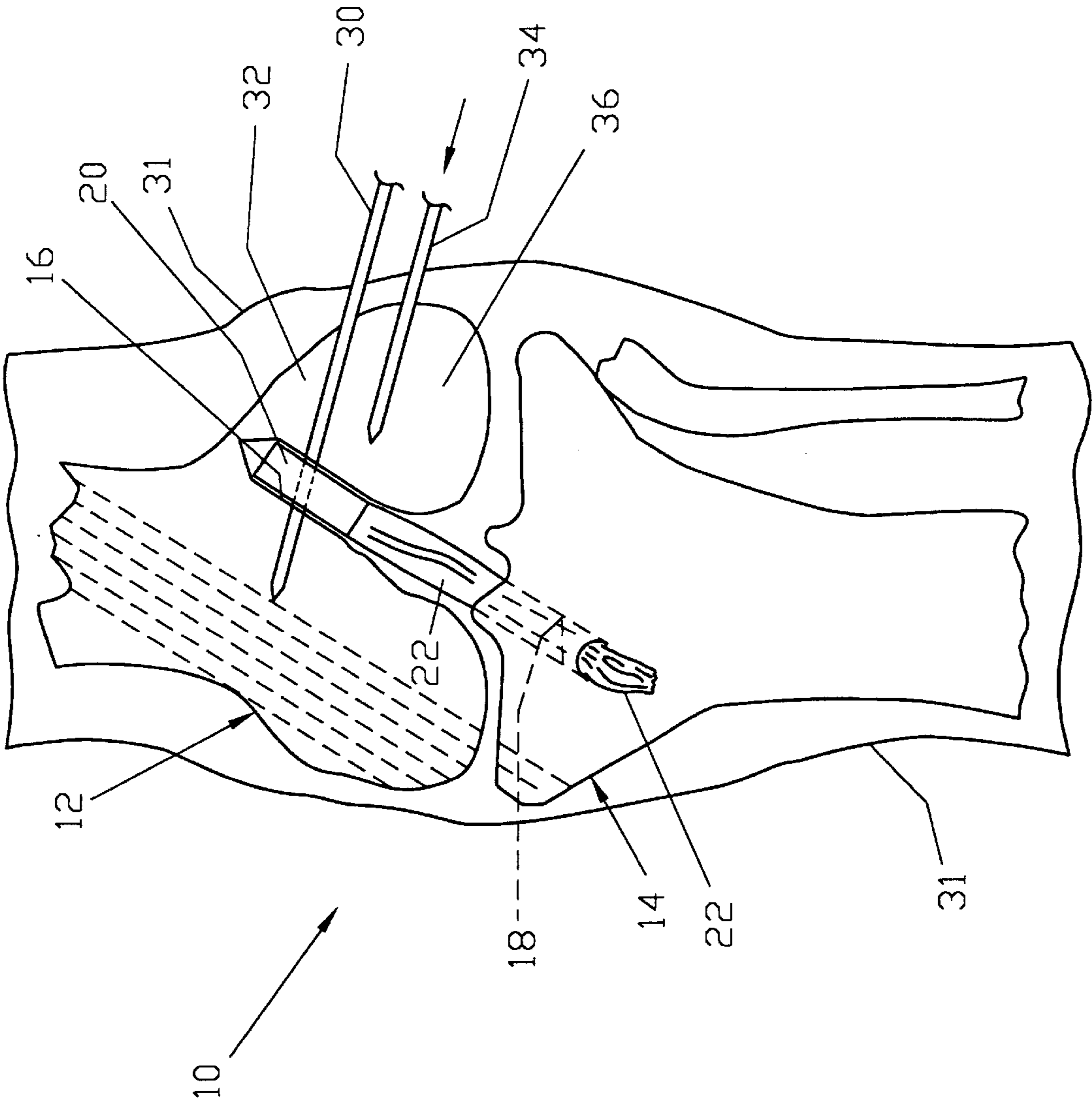

FIG. 2

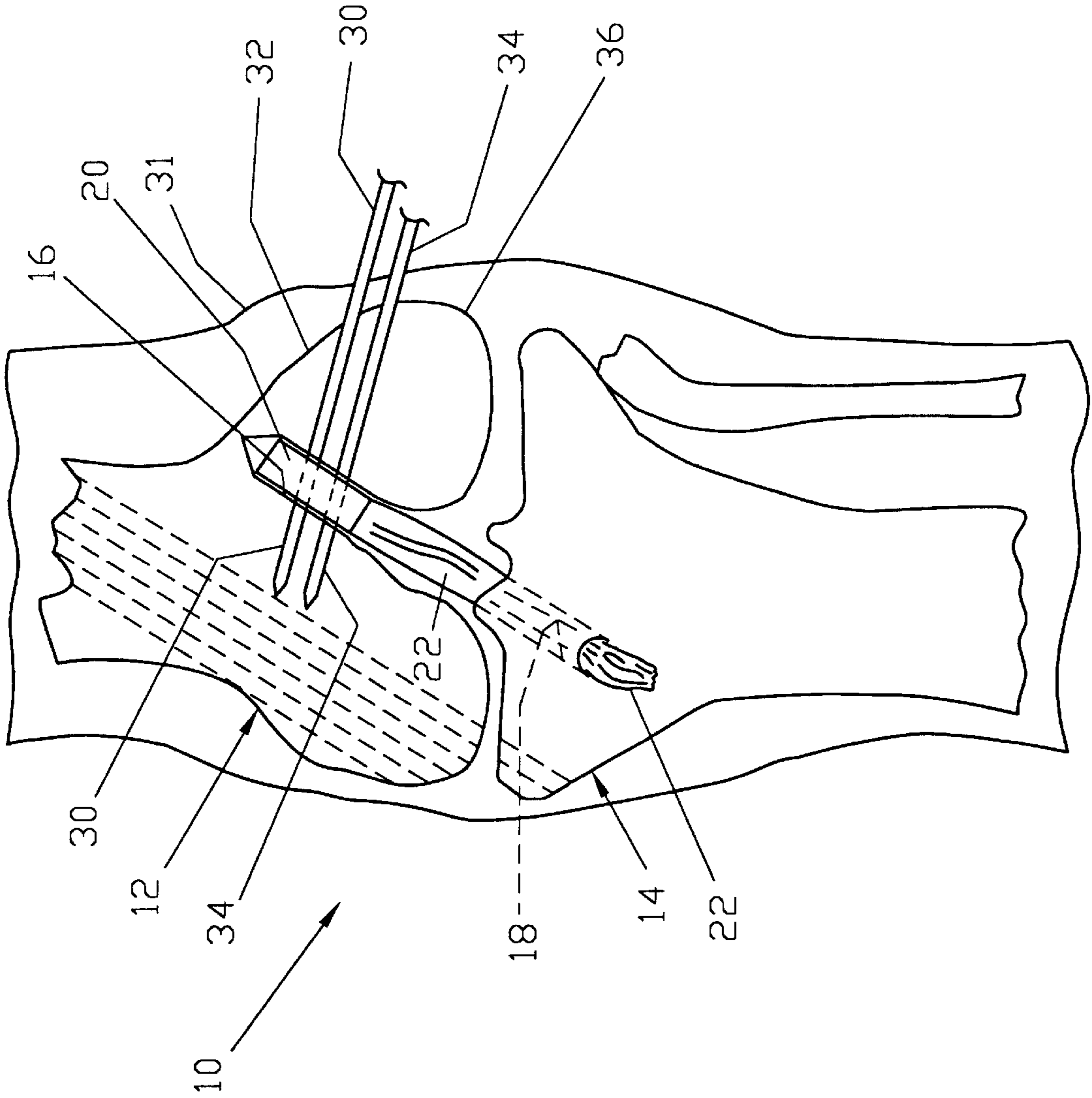

FIG. 3

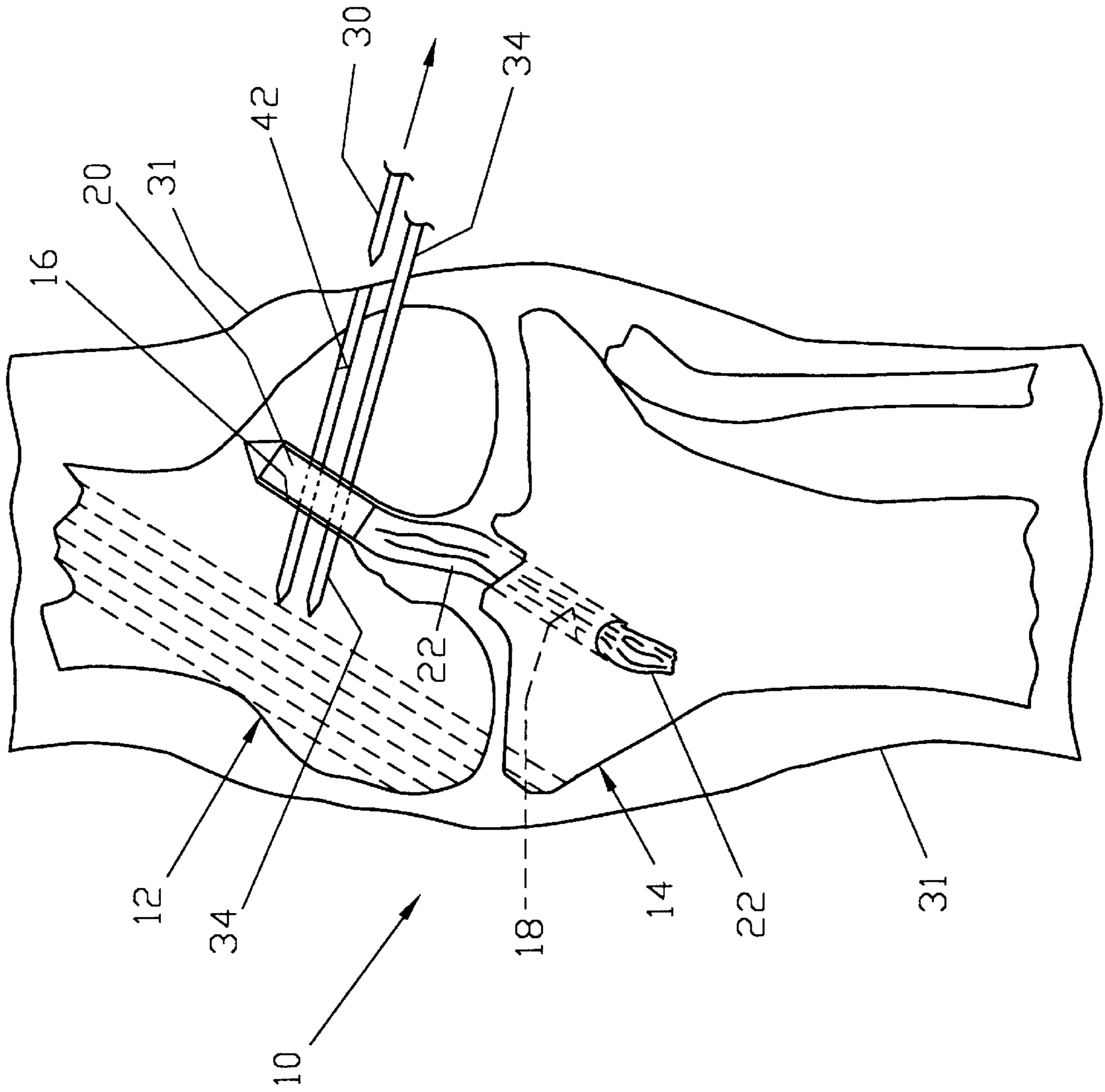

FIG. 4

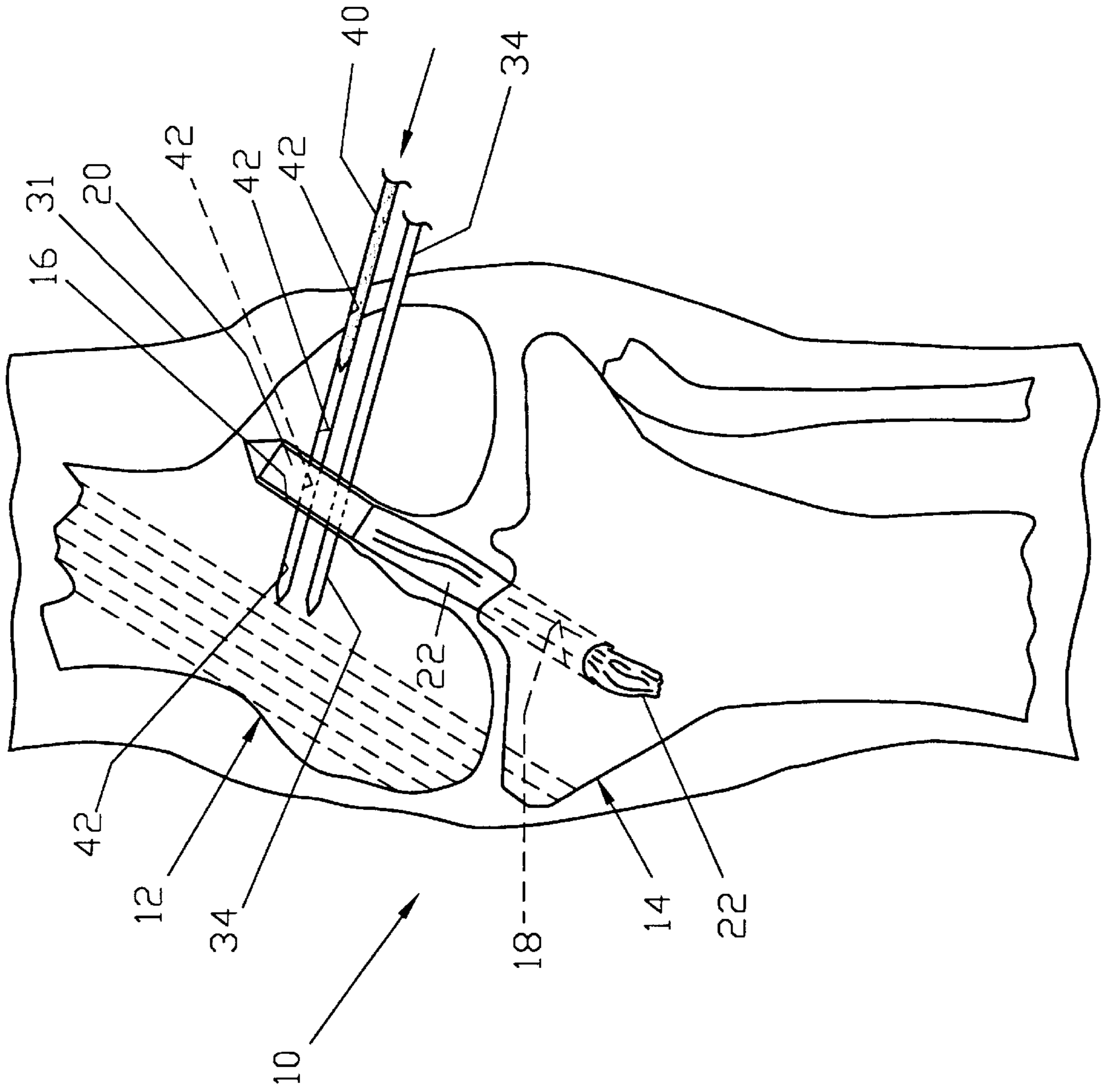

FIG. 5

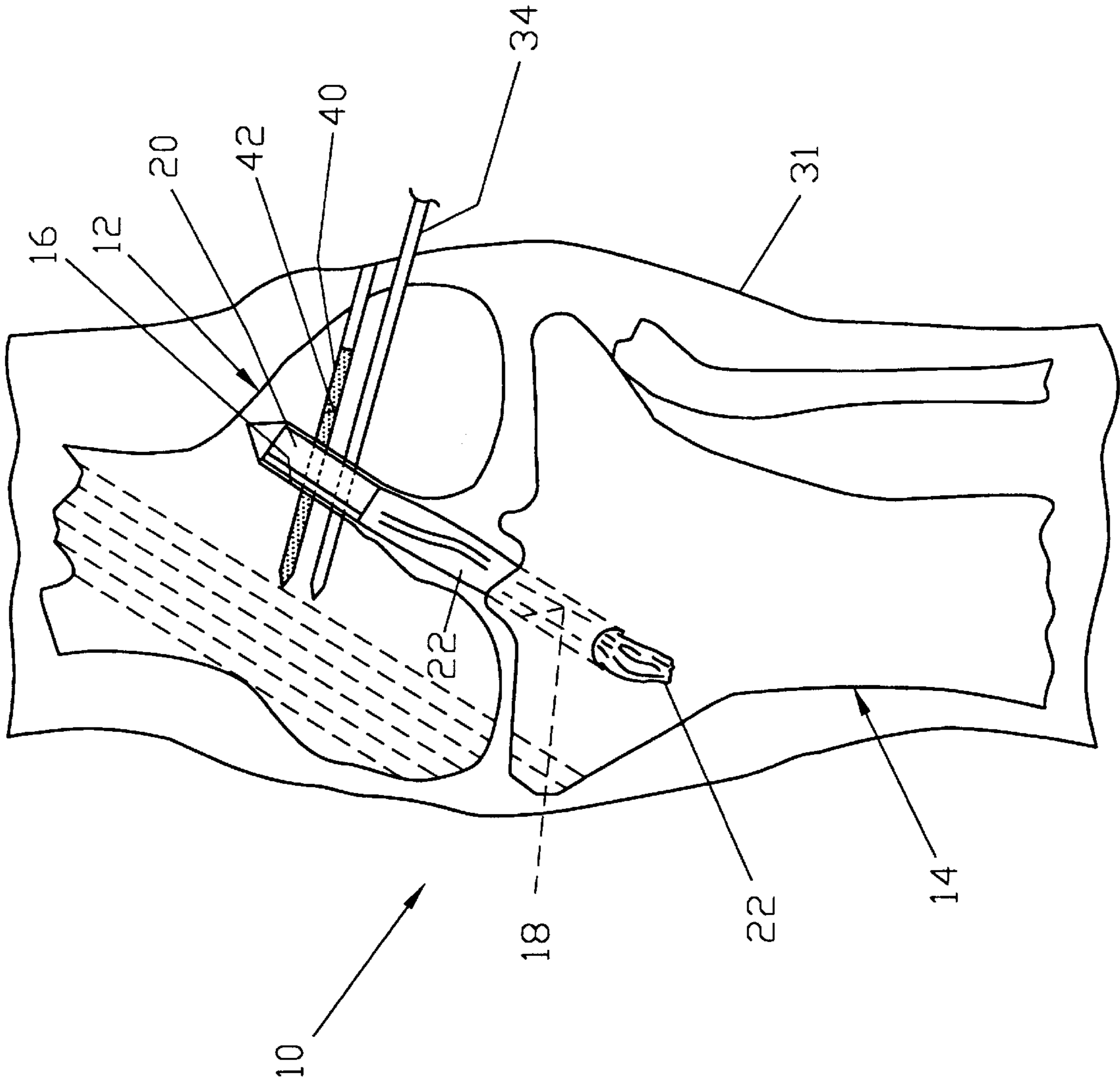

FIG. 6

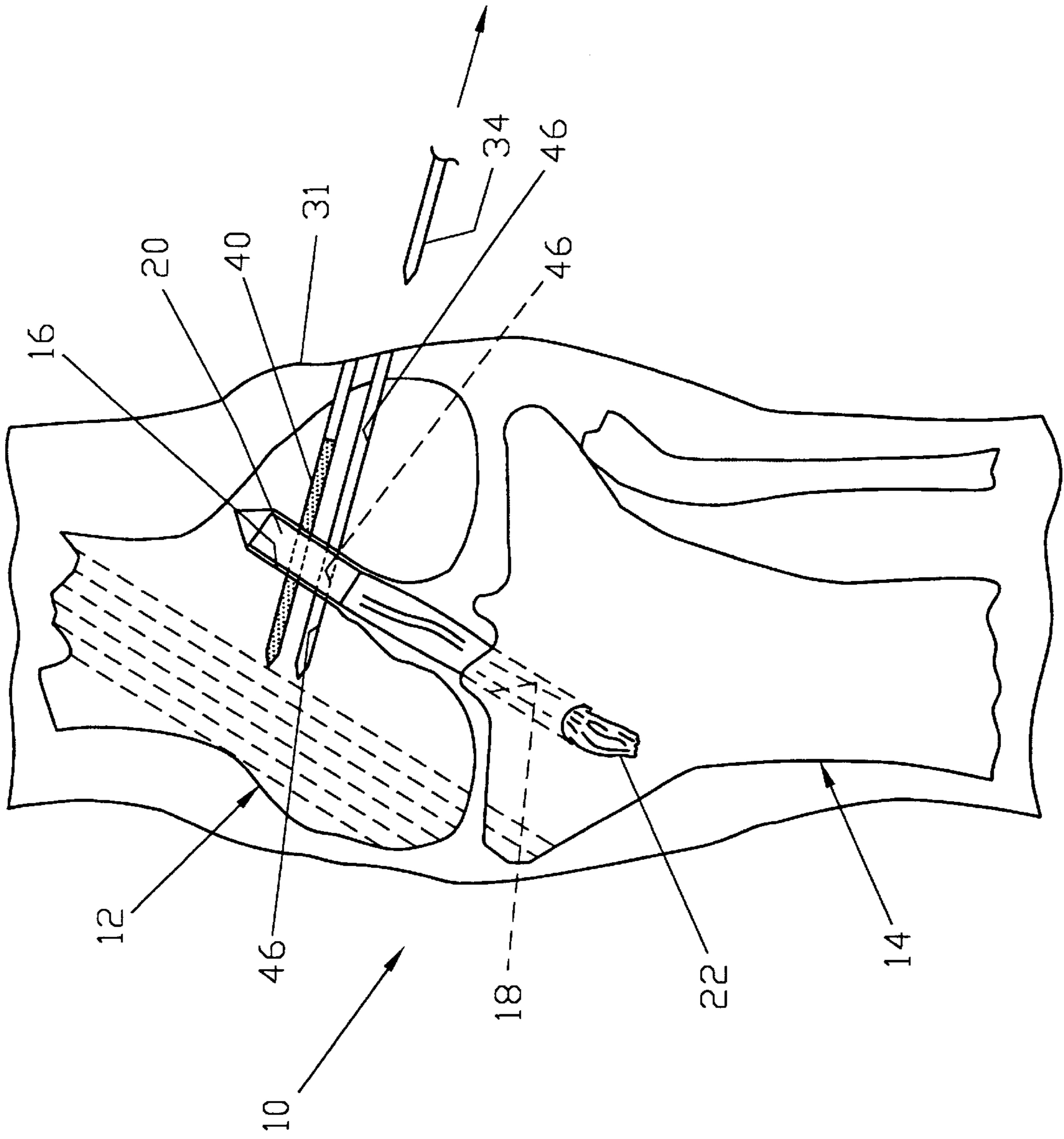

FIG. 7

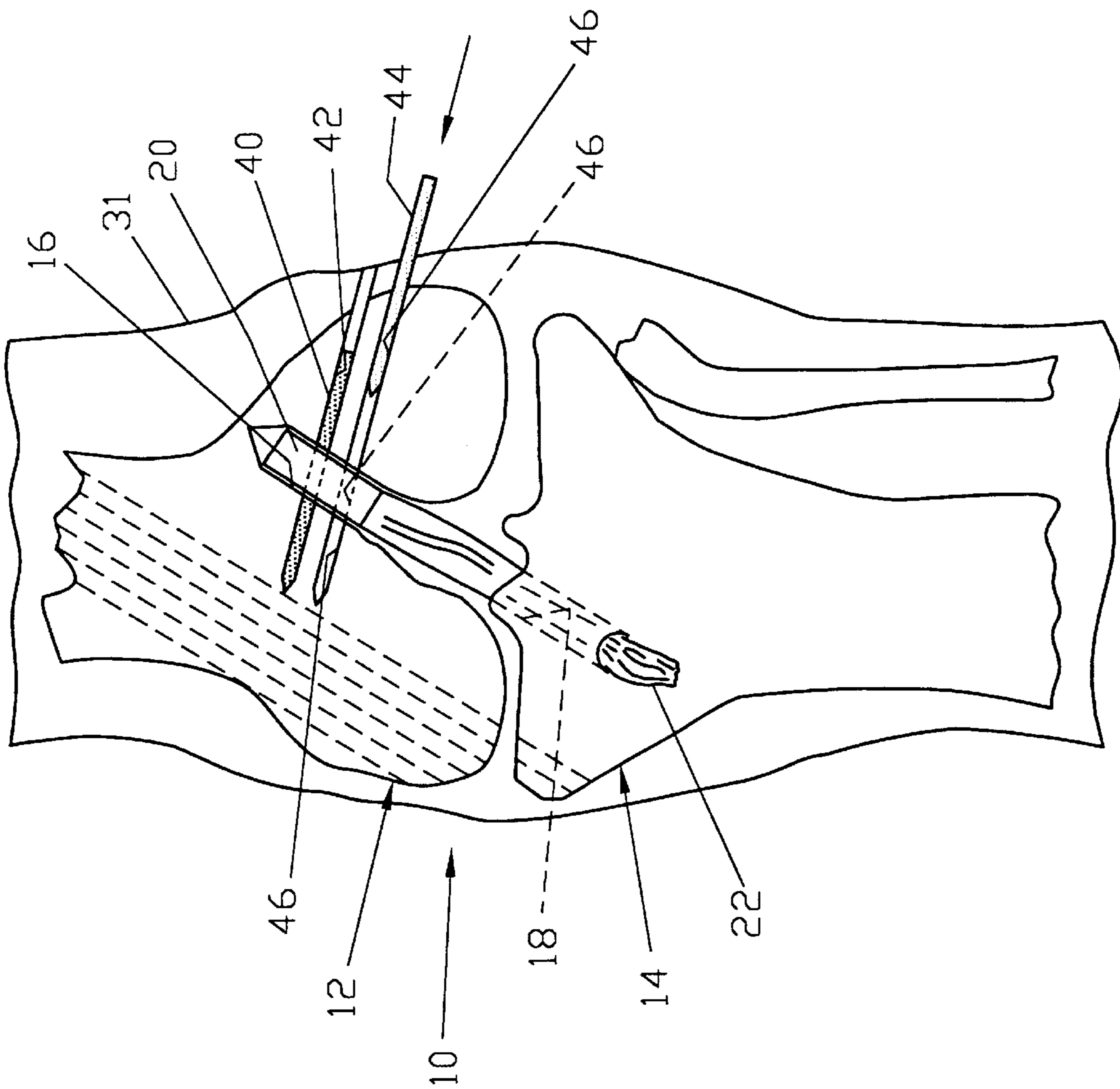

FIG. 8

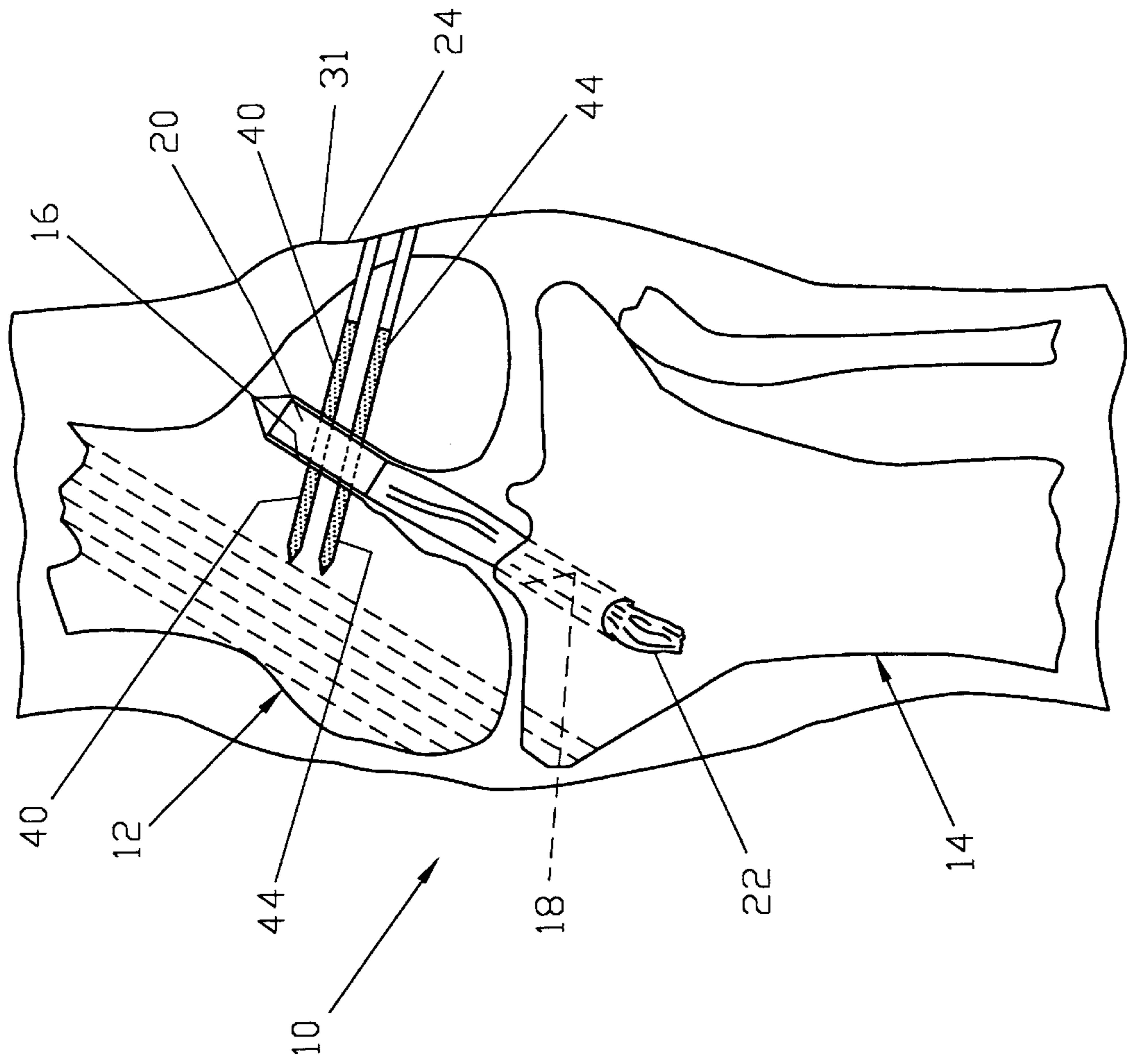

FIG. 9

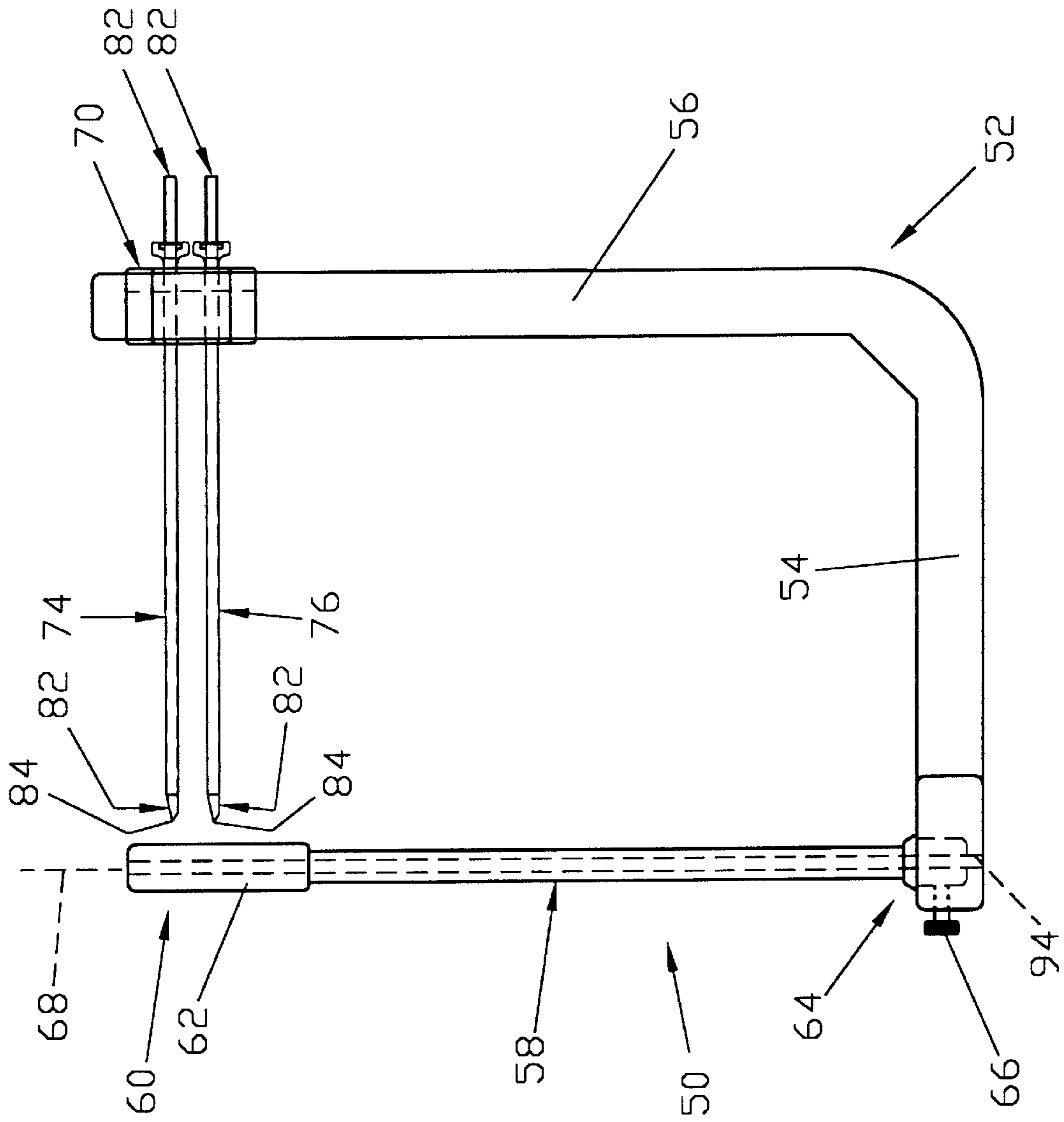

FIG. 10

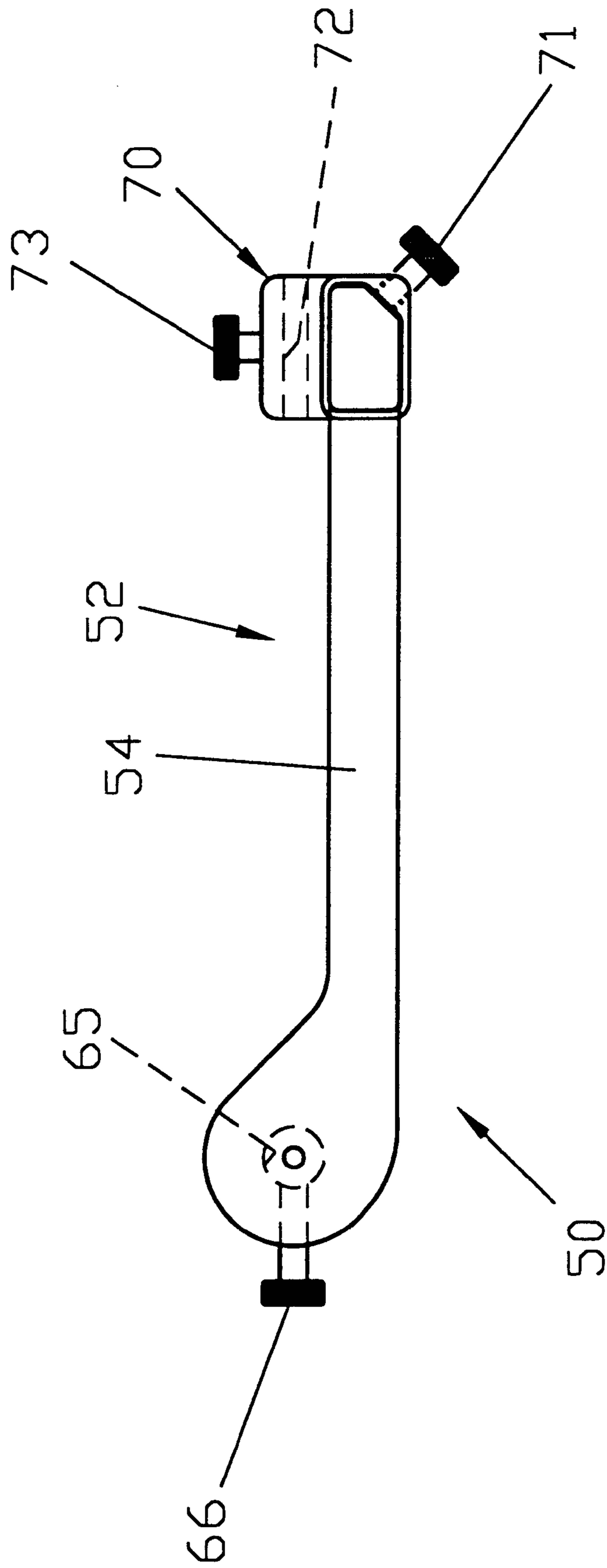

FIG. 11

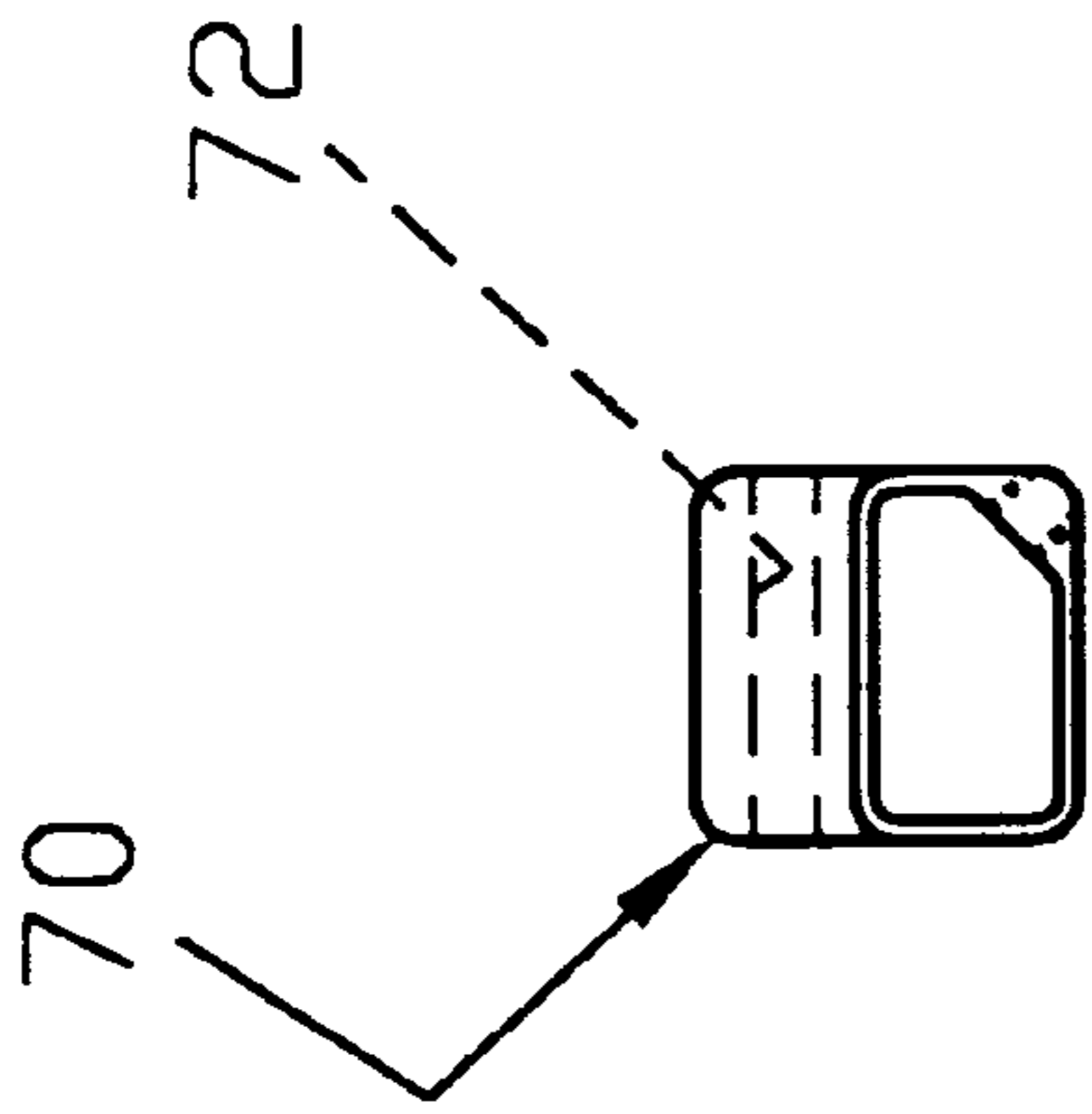

FIG. 12

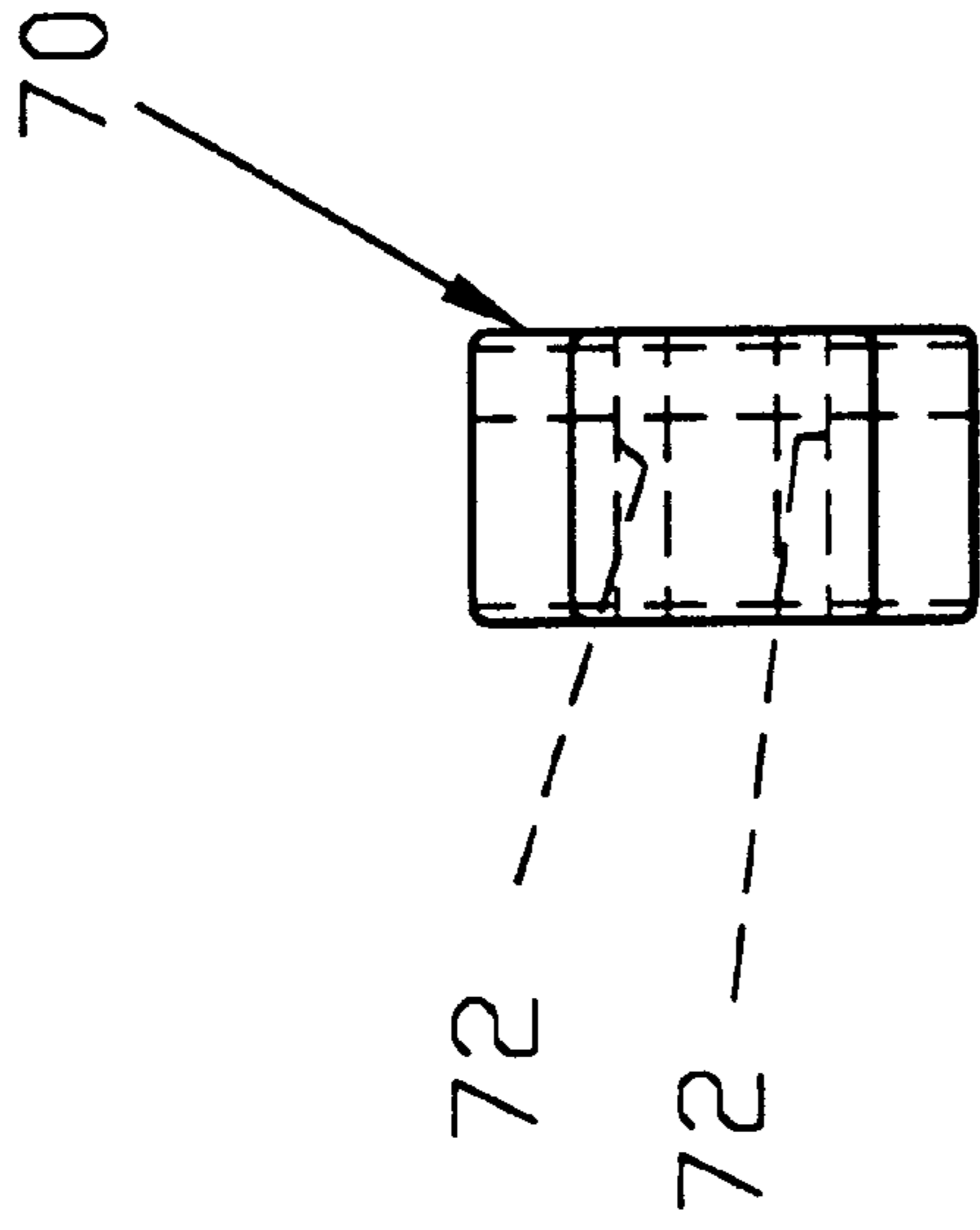

FIG. 13

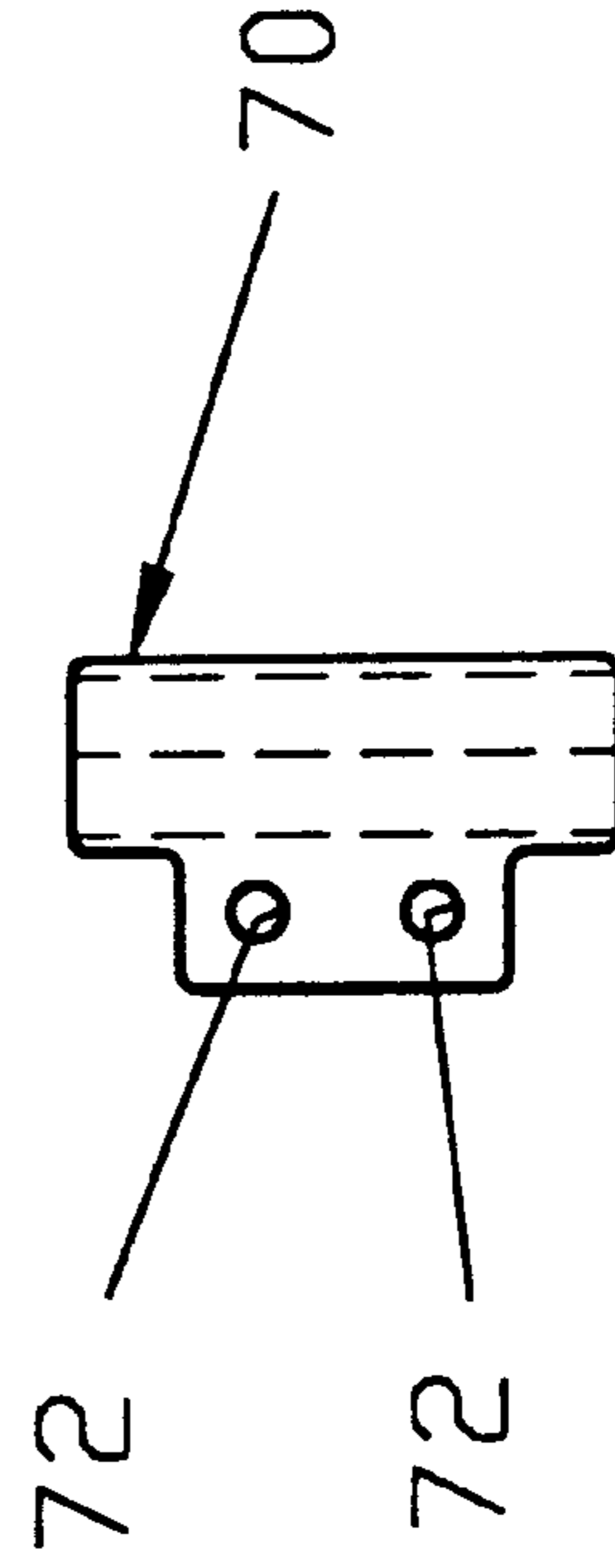
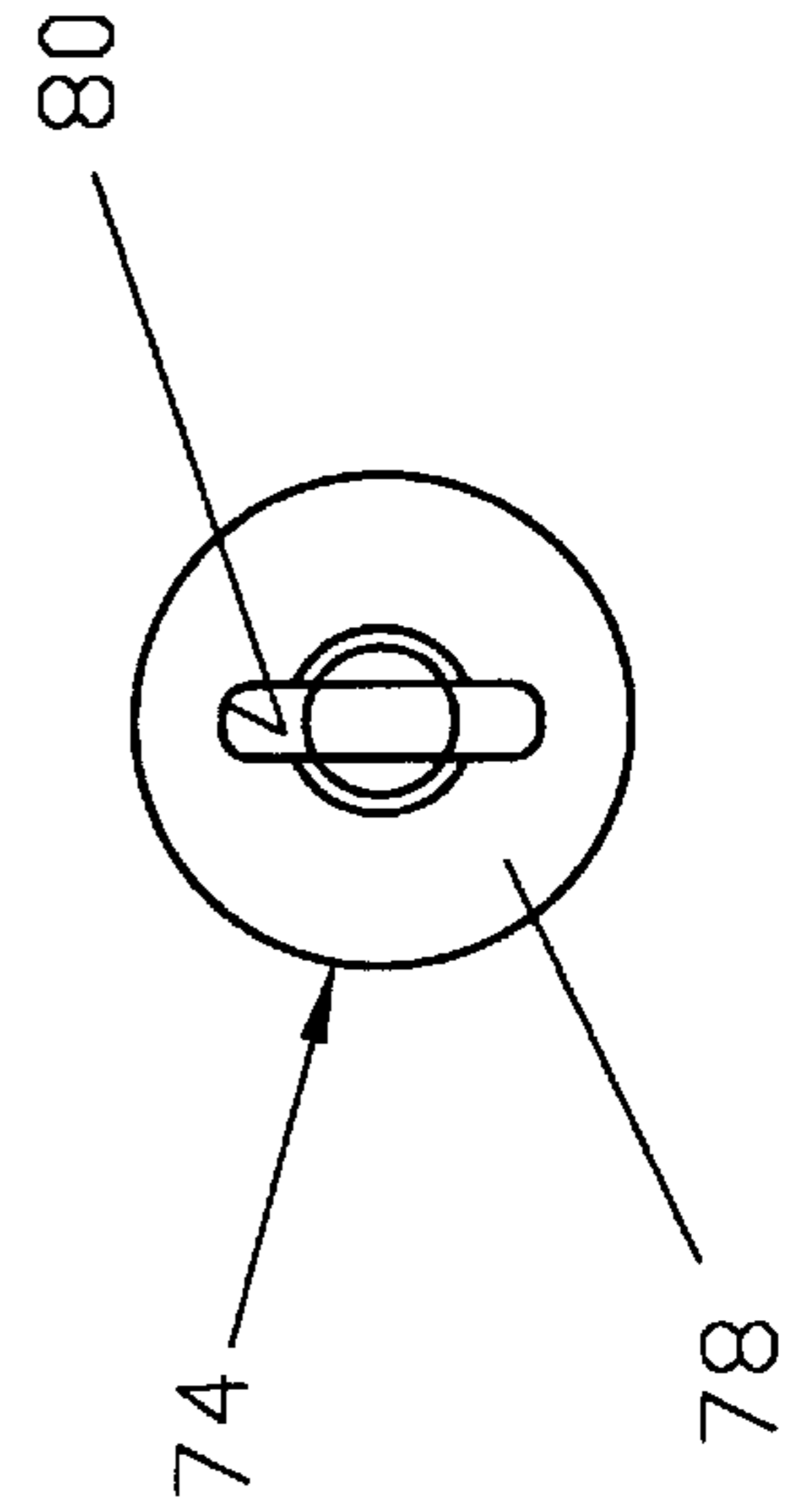
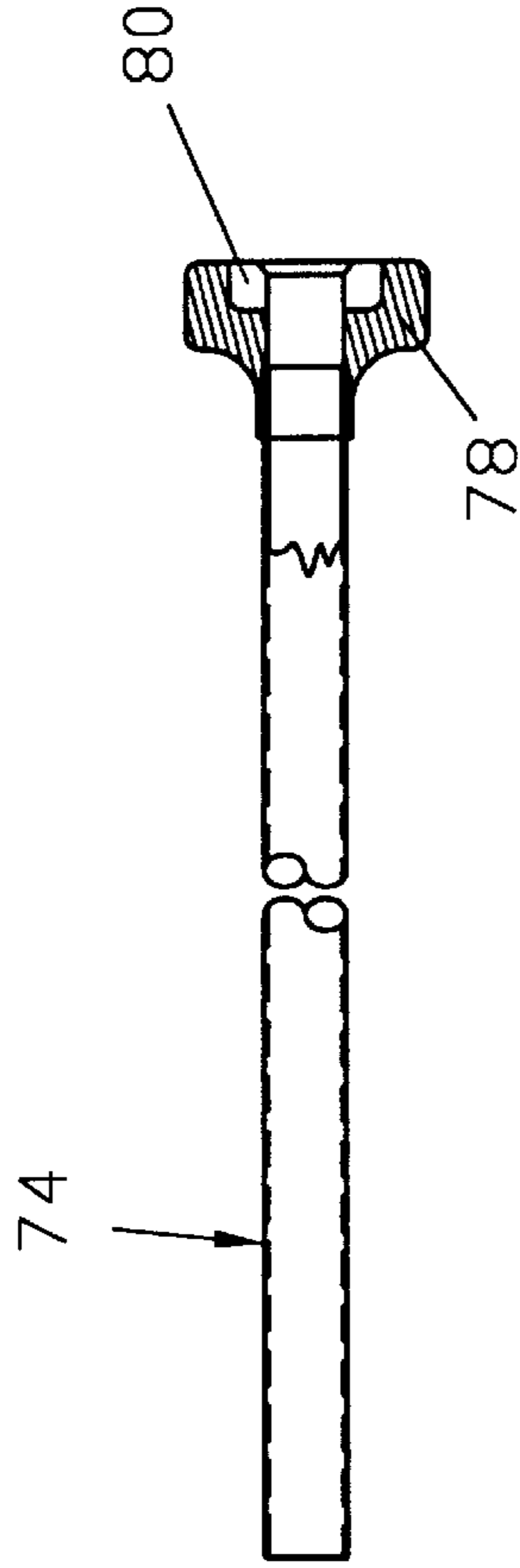
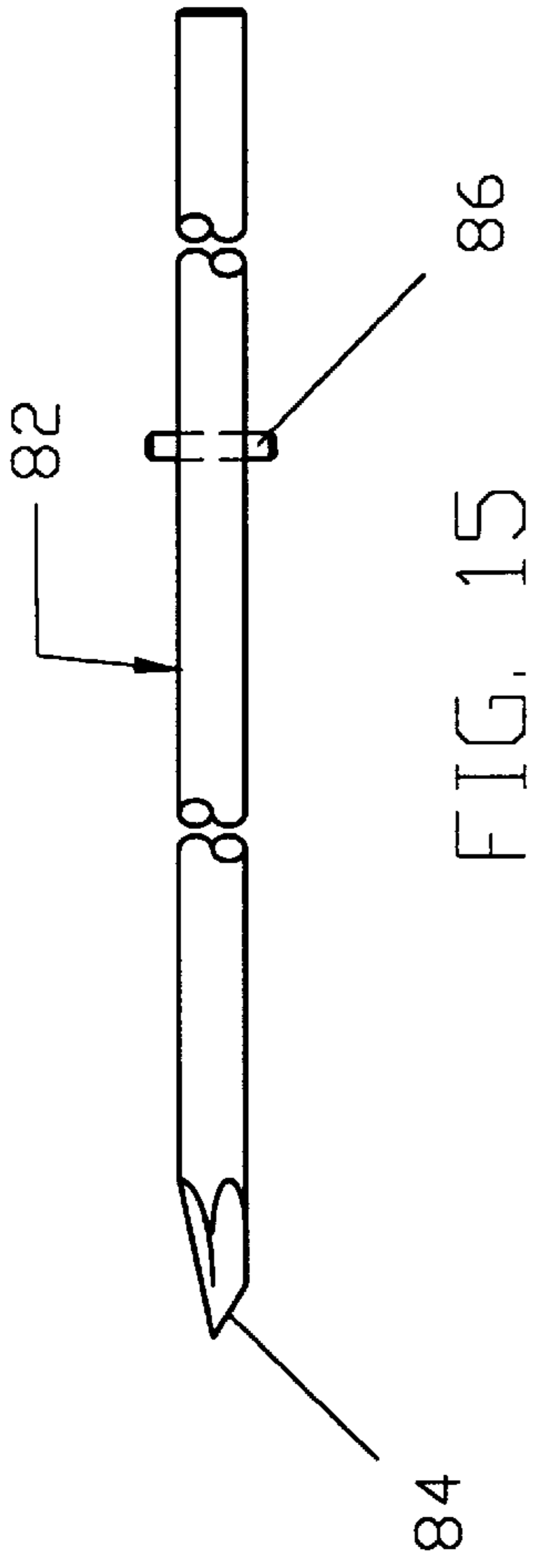

FIG. 14



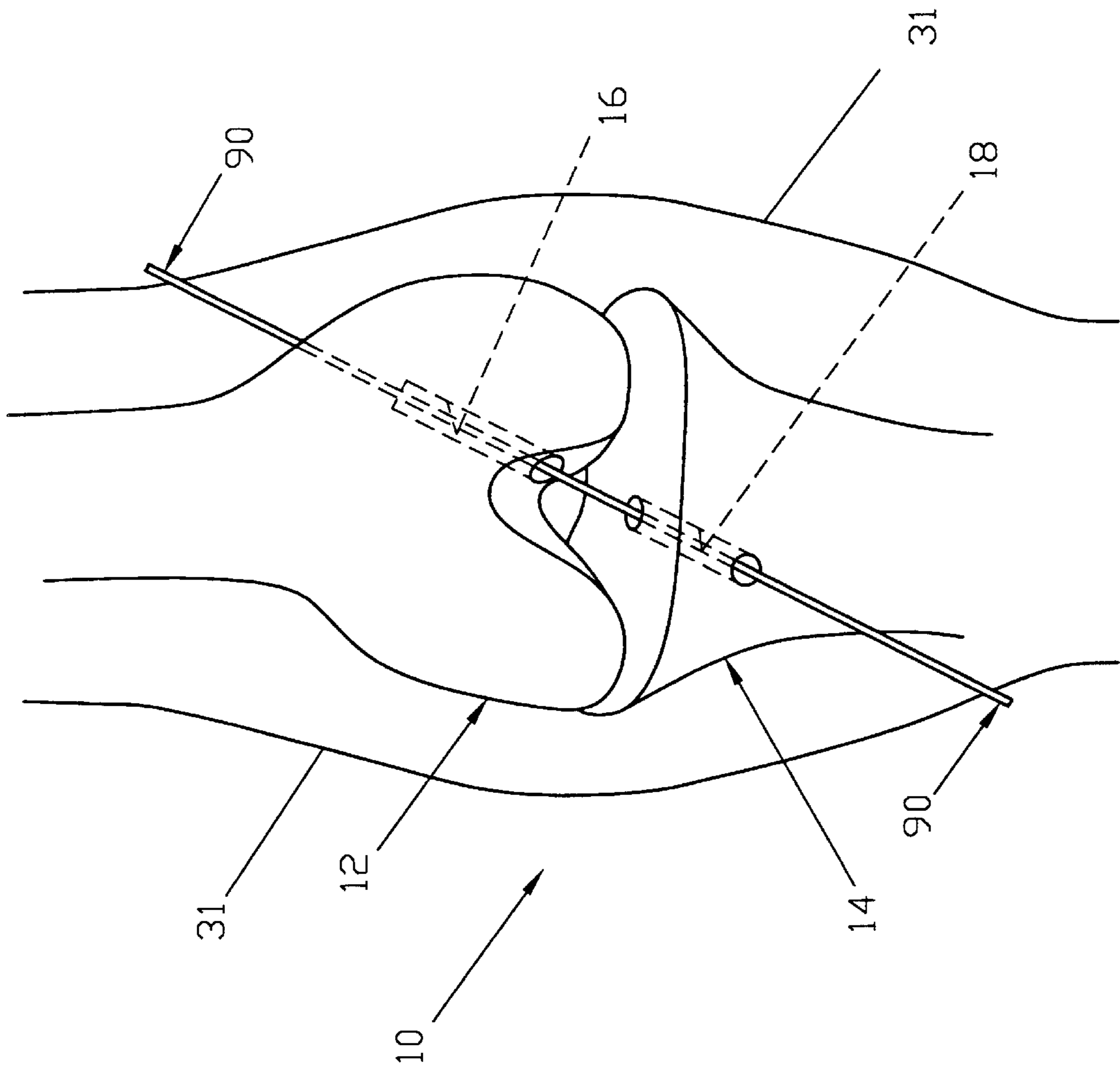

FIG. 18

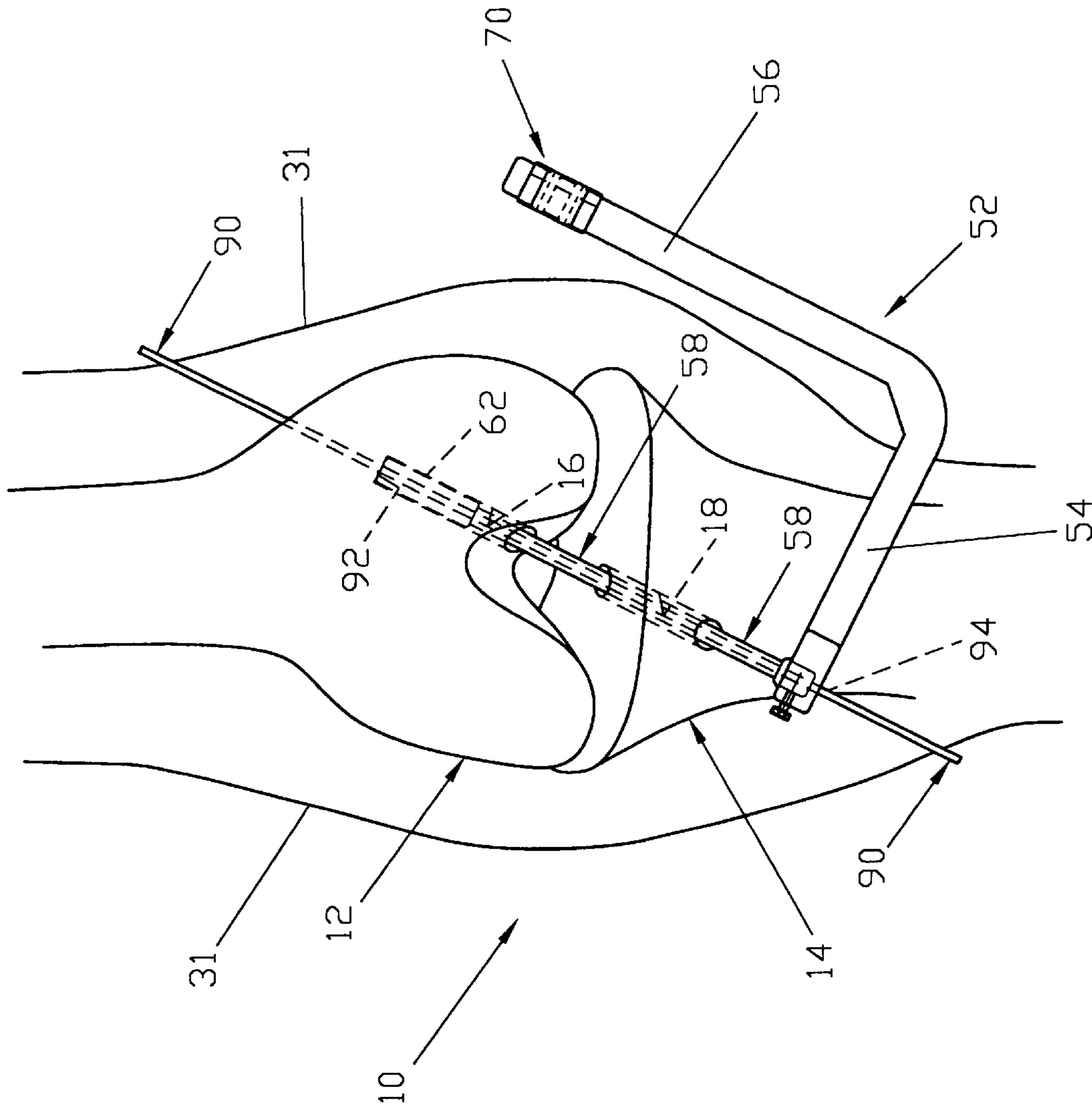

FIG. 19

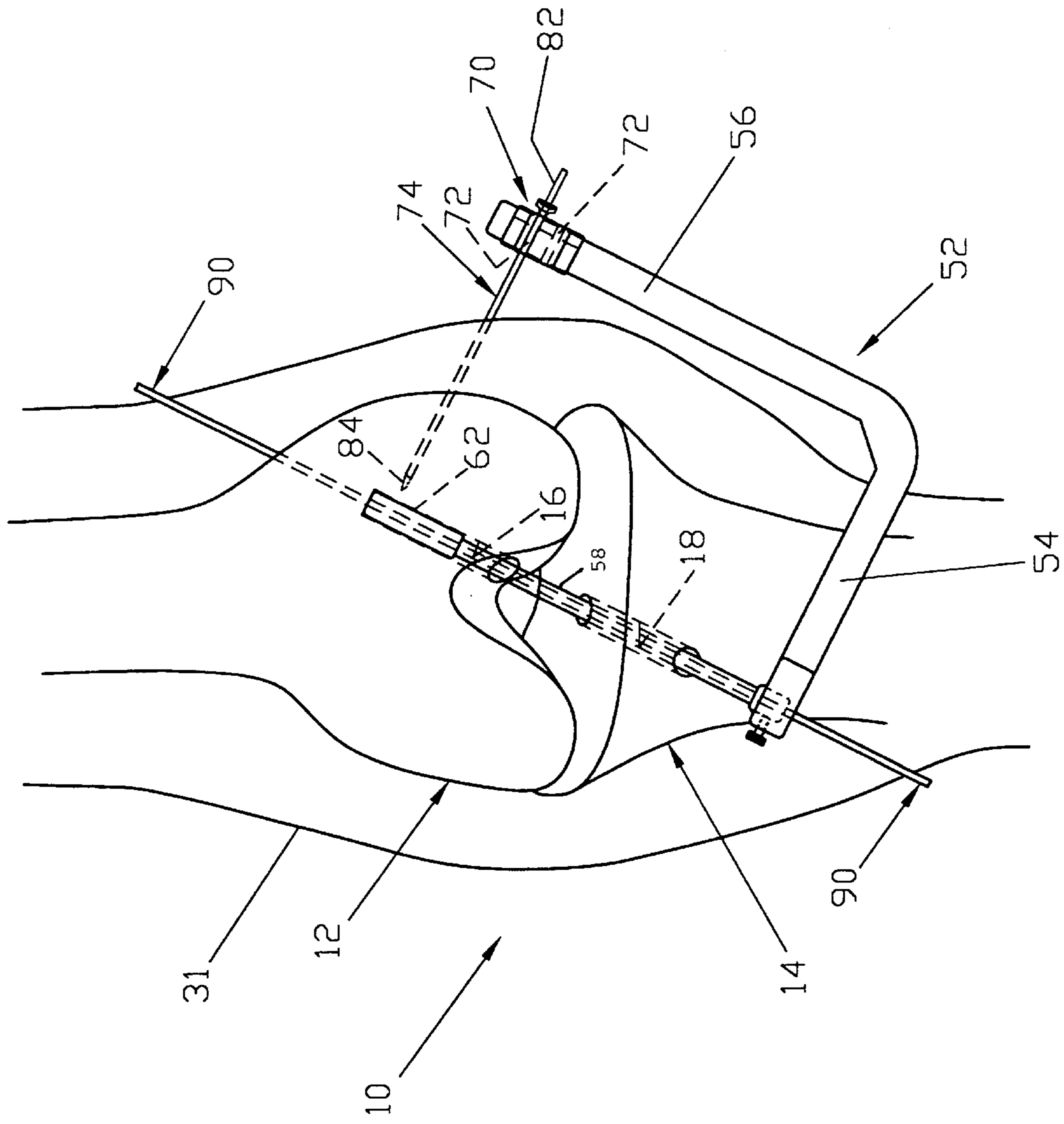

FIG. 20

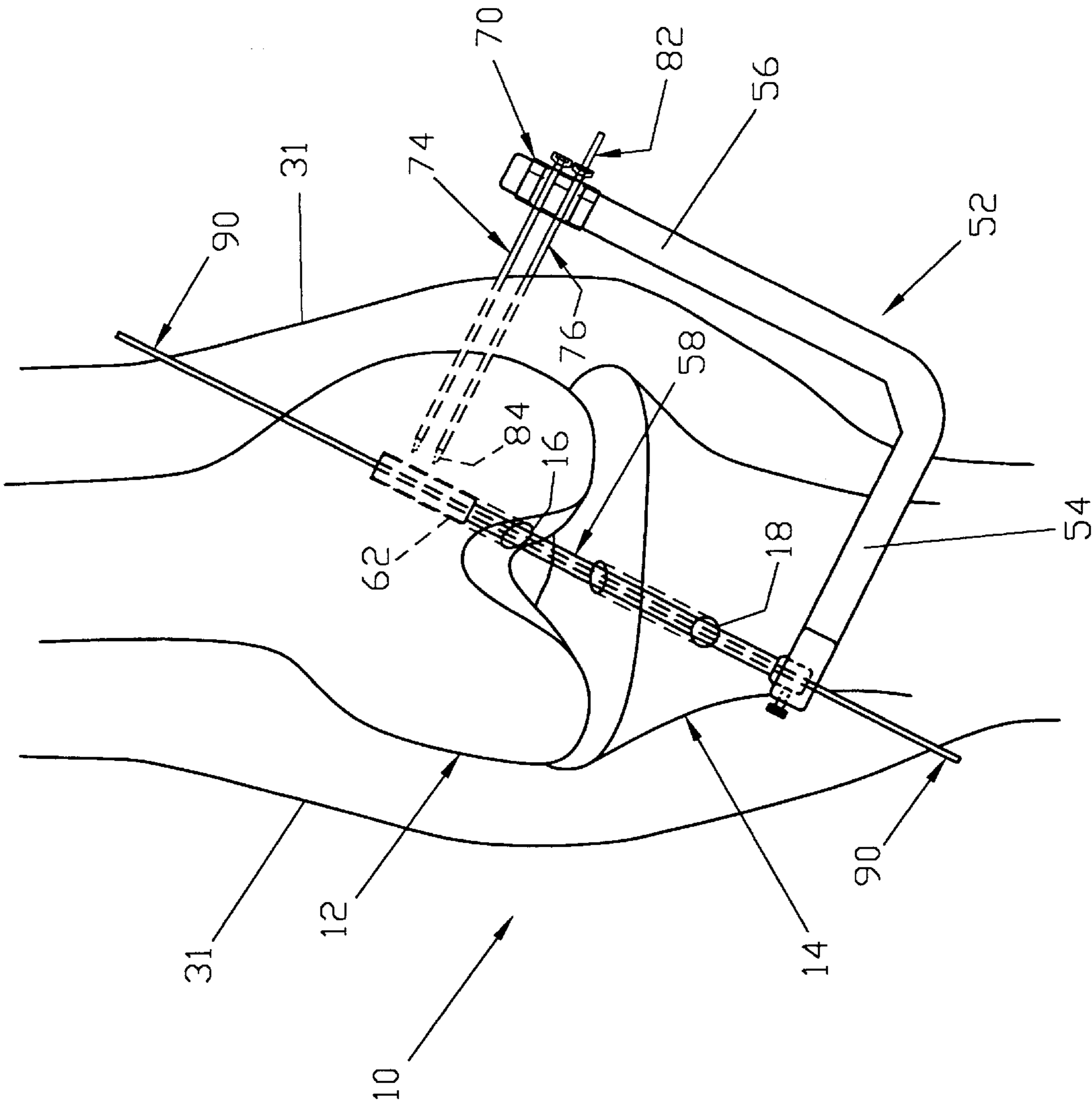

FIG. 21

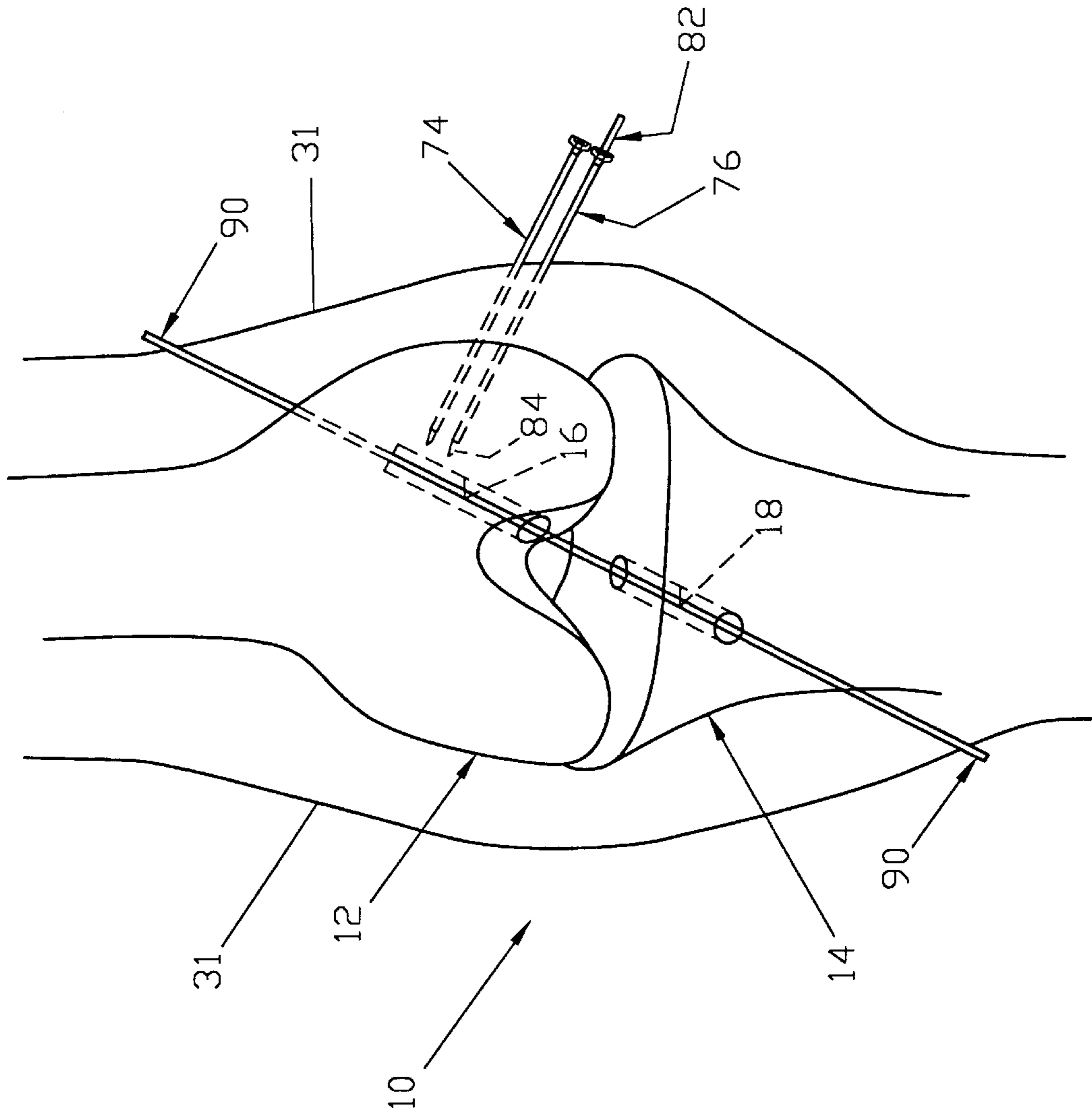

FIG. 22

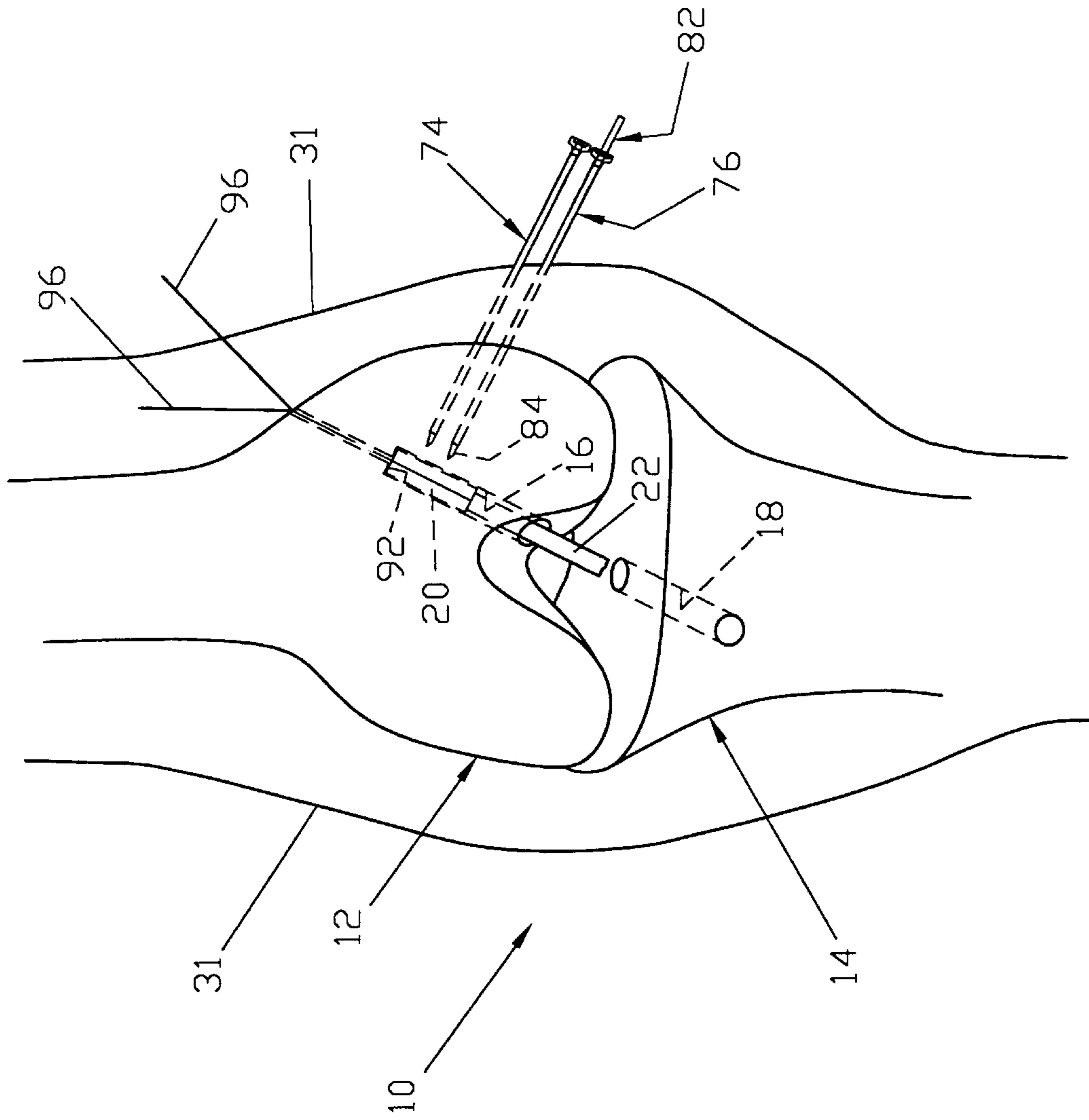

FIG. 23

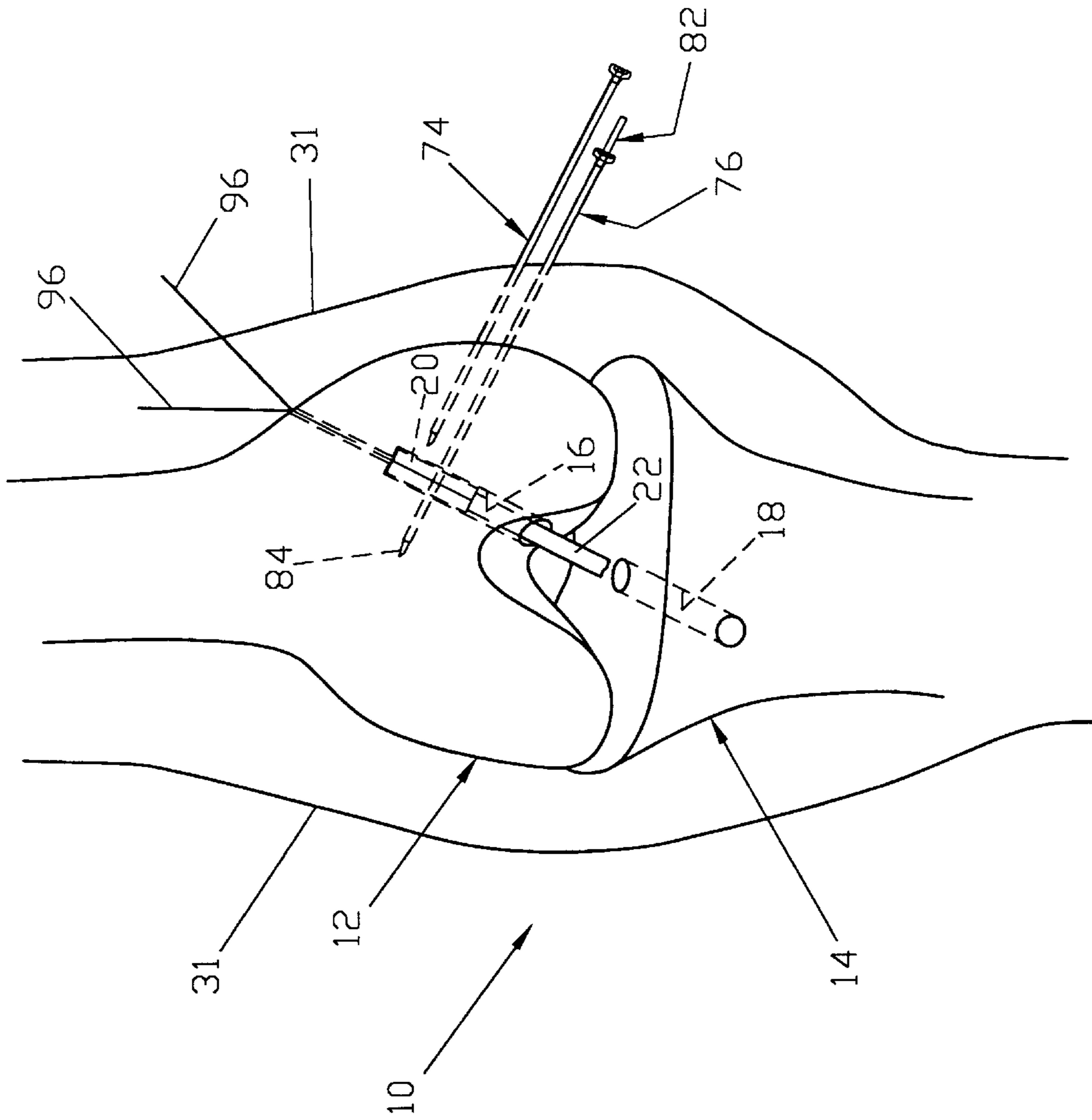

FIG. 24

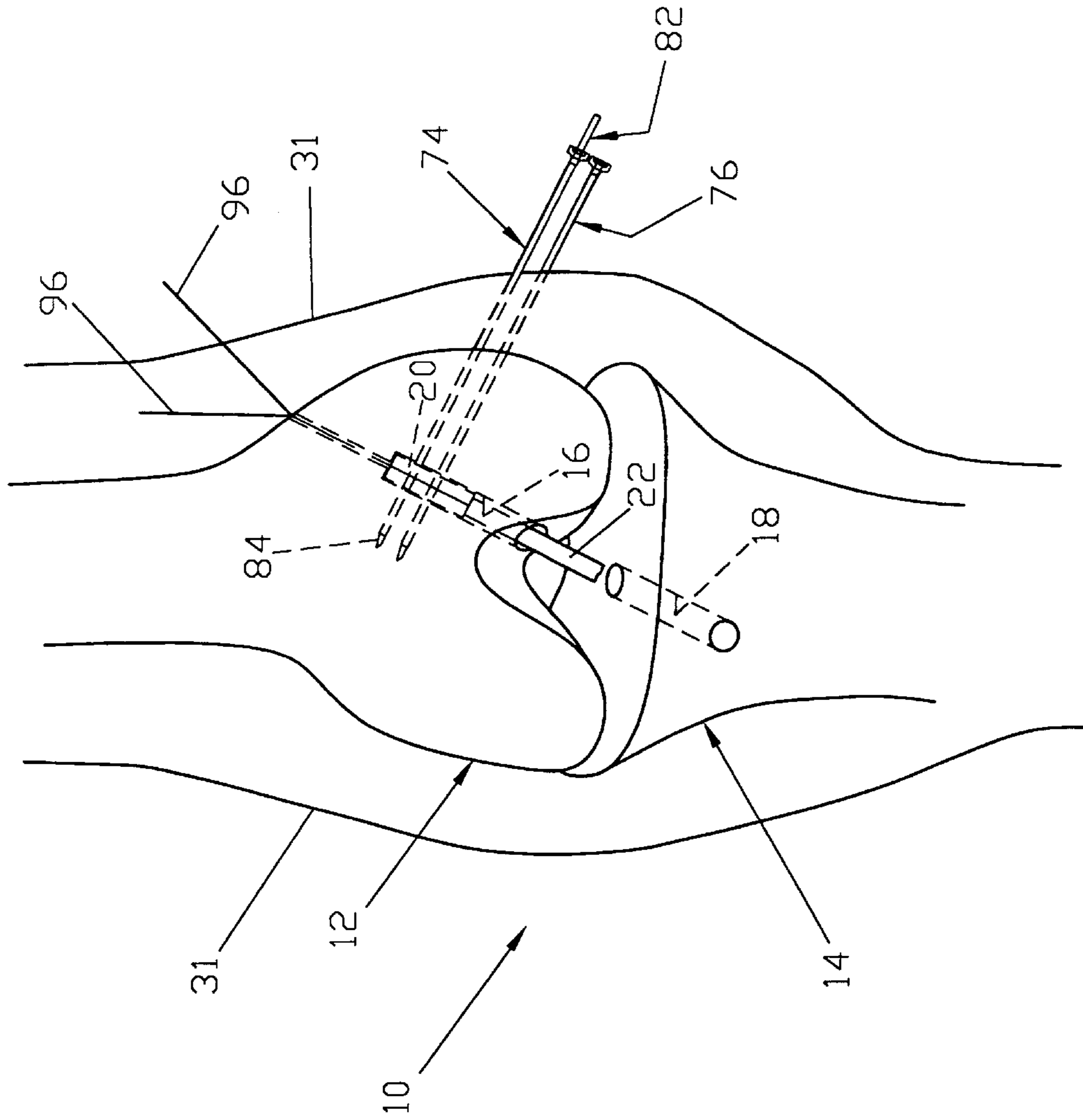

FIG. 25

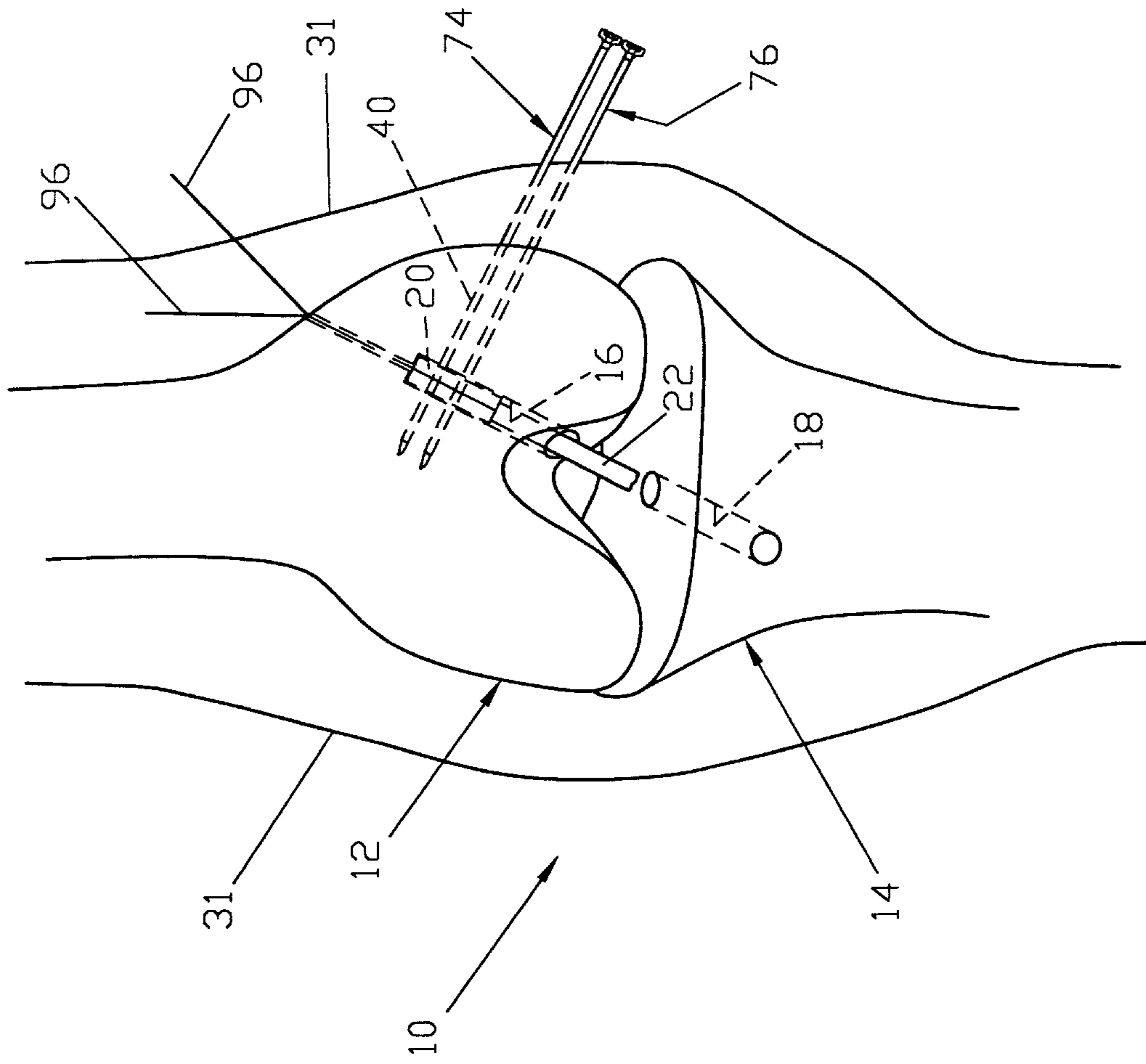

FIG. 26

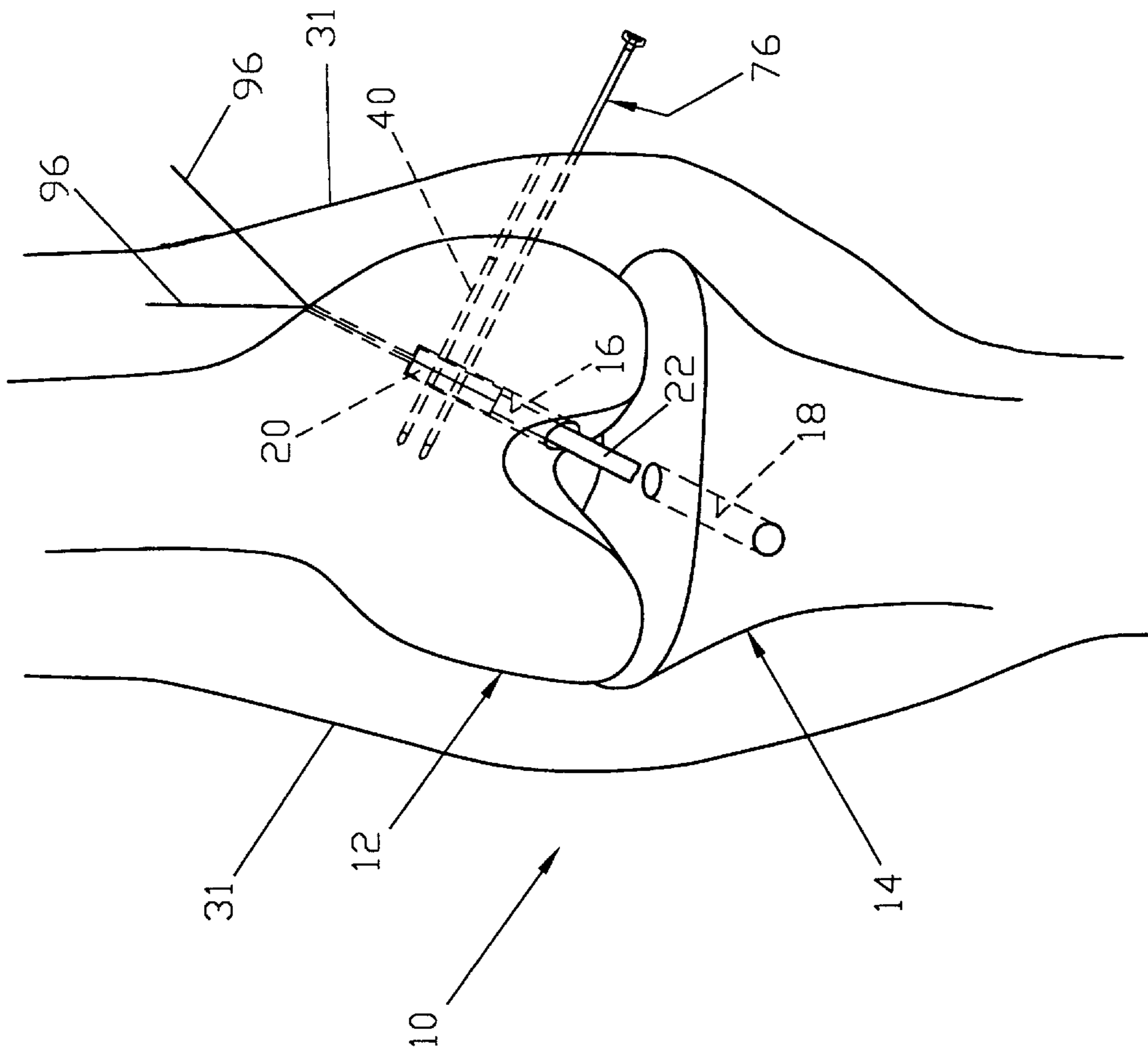

FIG. 27

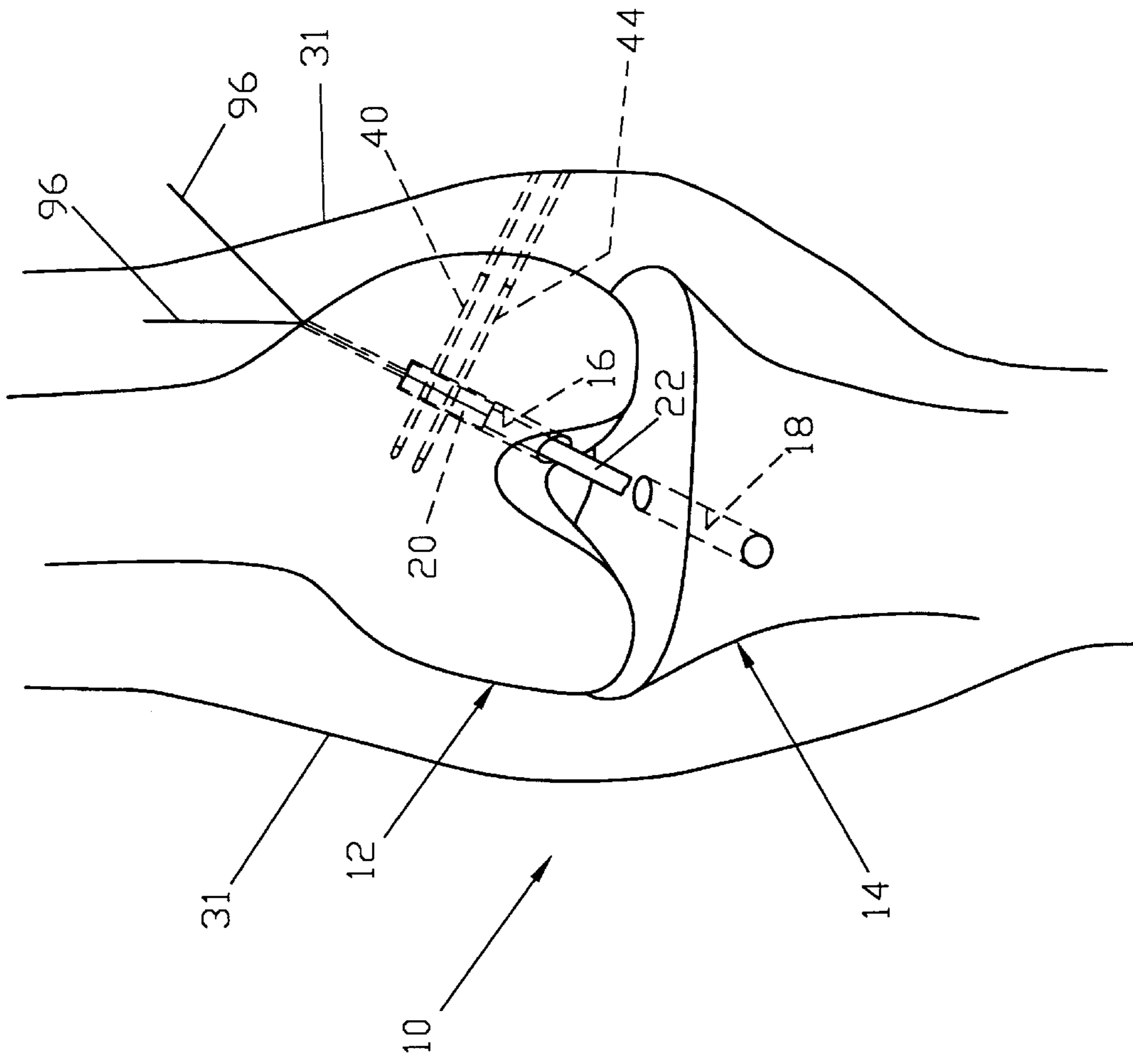

FIG. 28

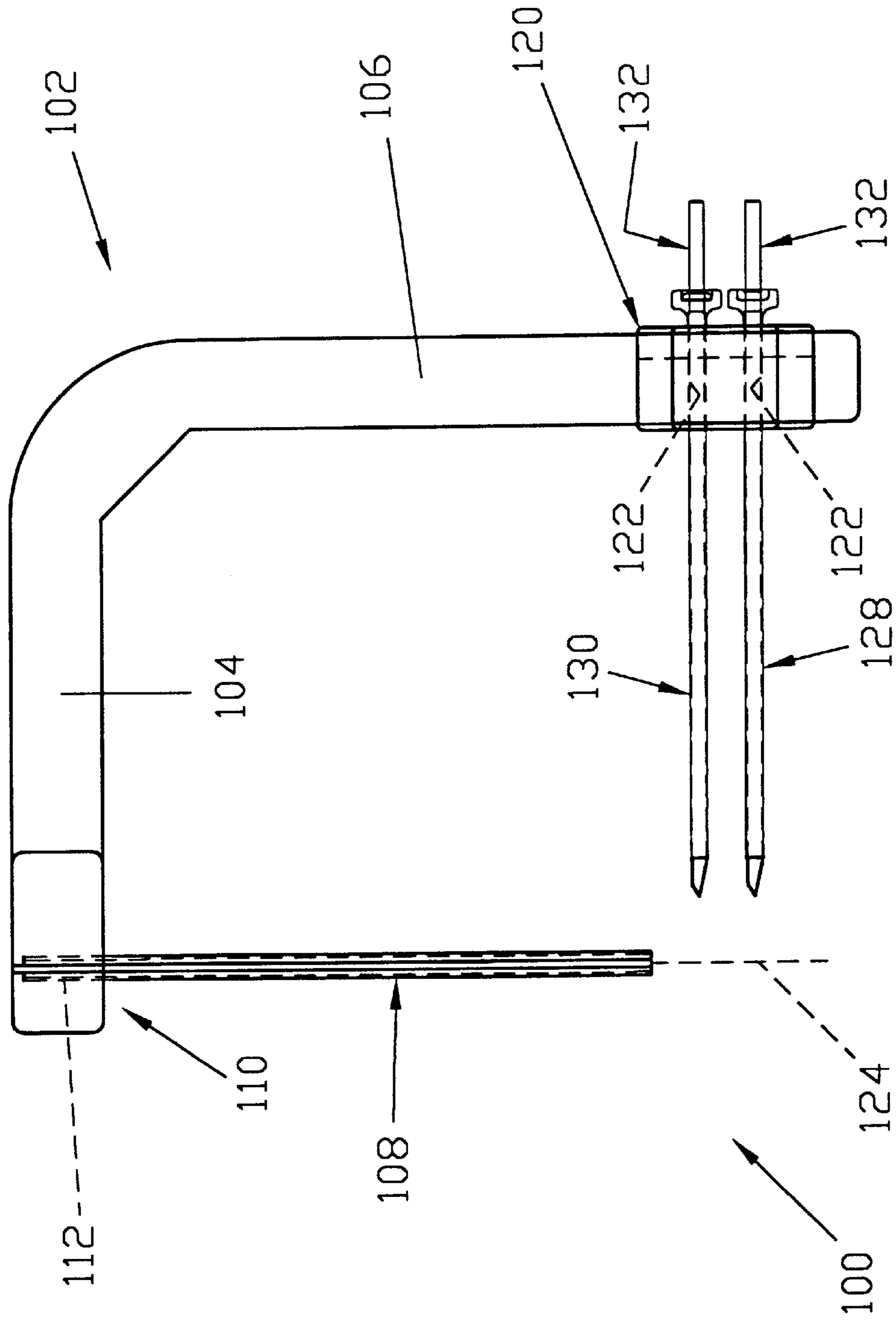

FIG. 29

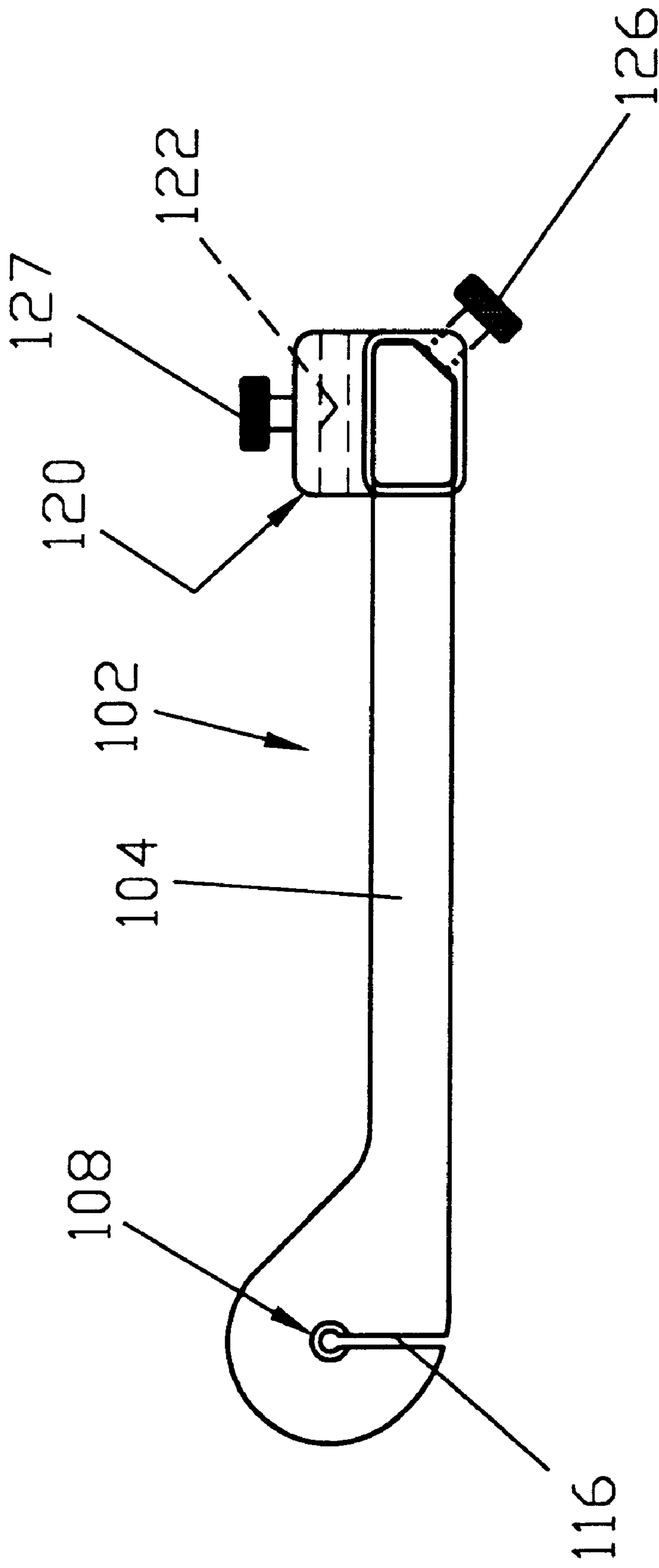

FIG. 30

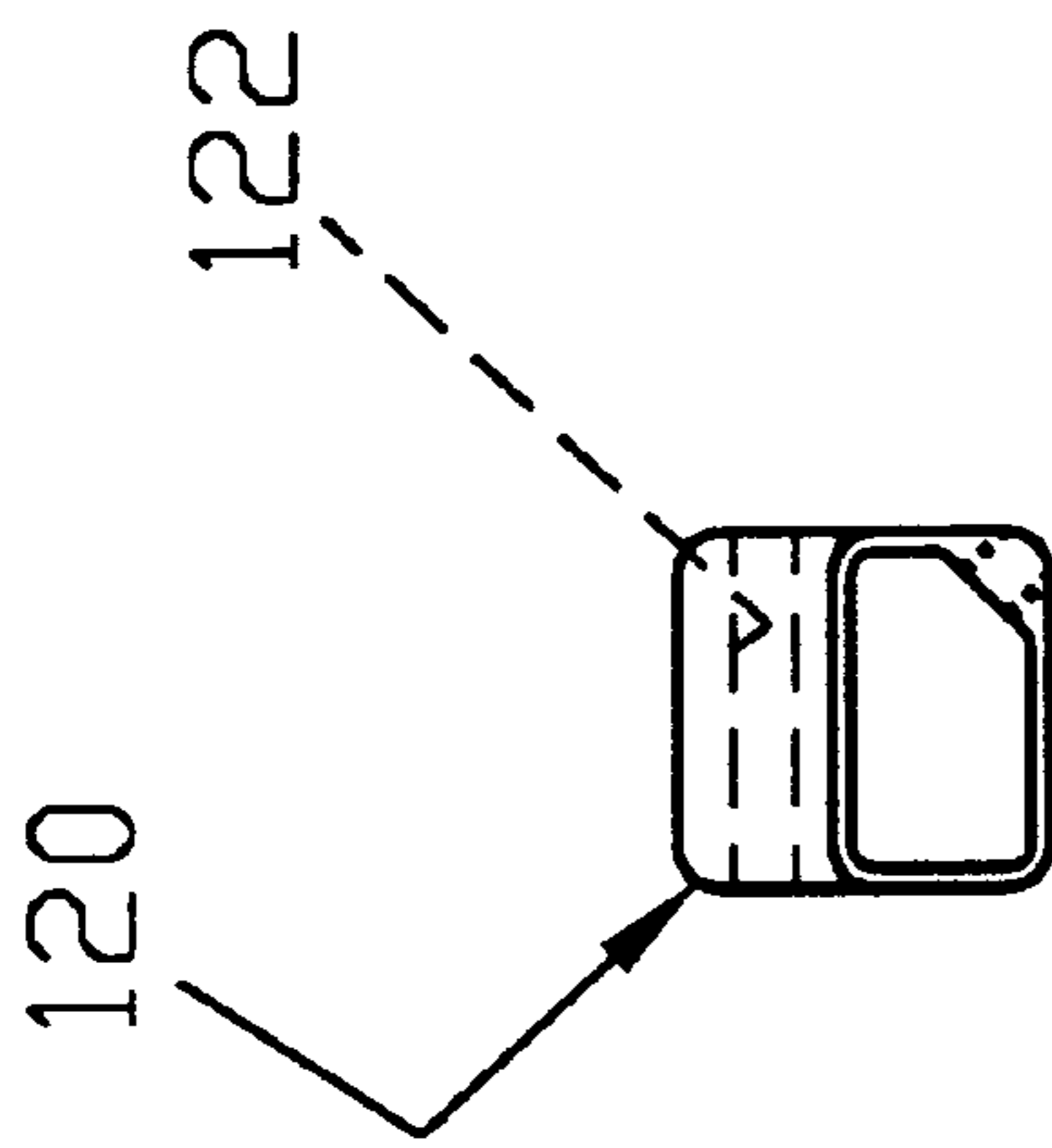

FIG. 31

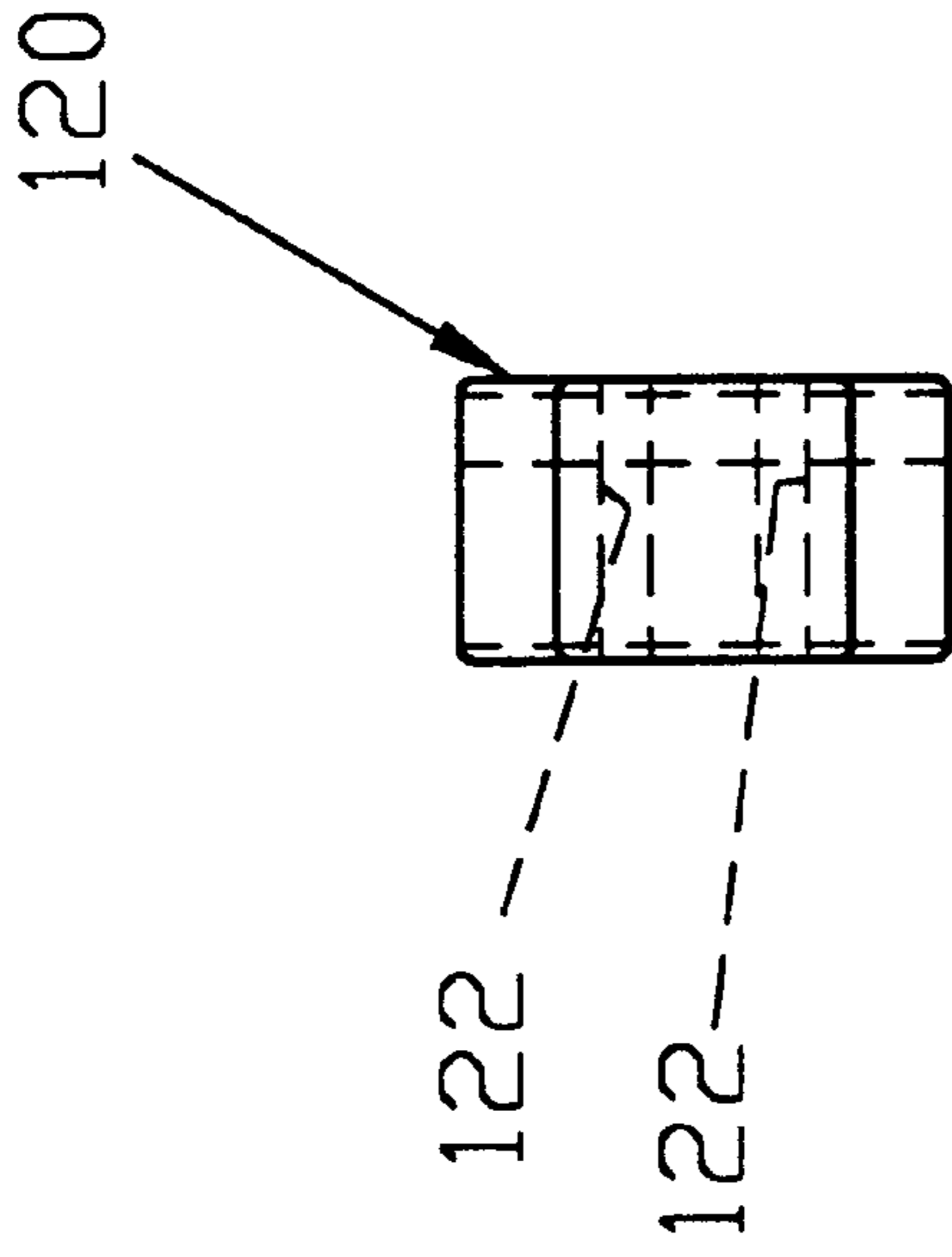

FIG. 32

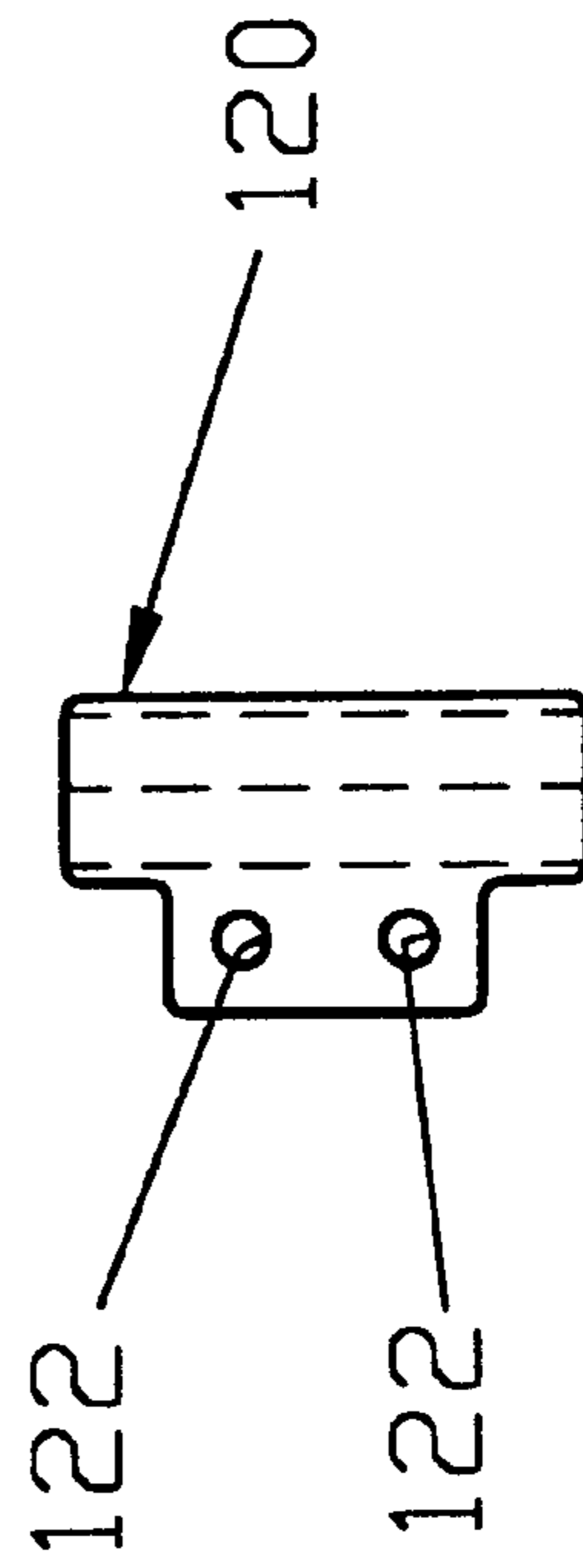

FIG. 33

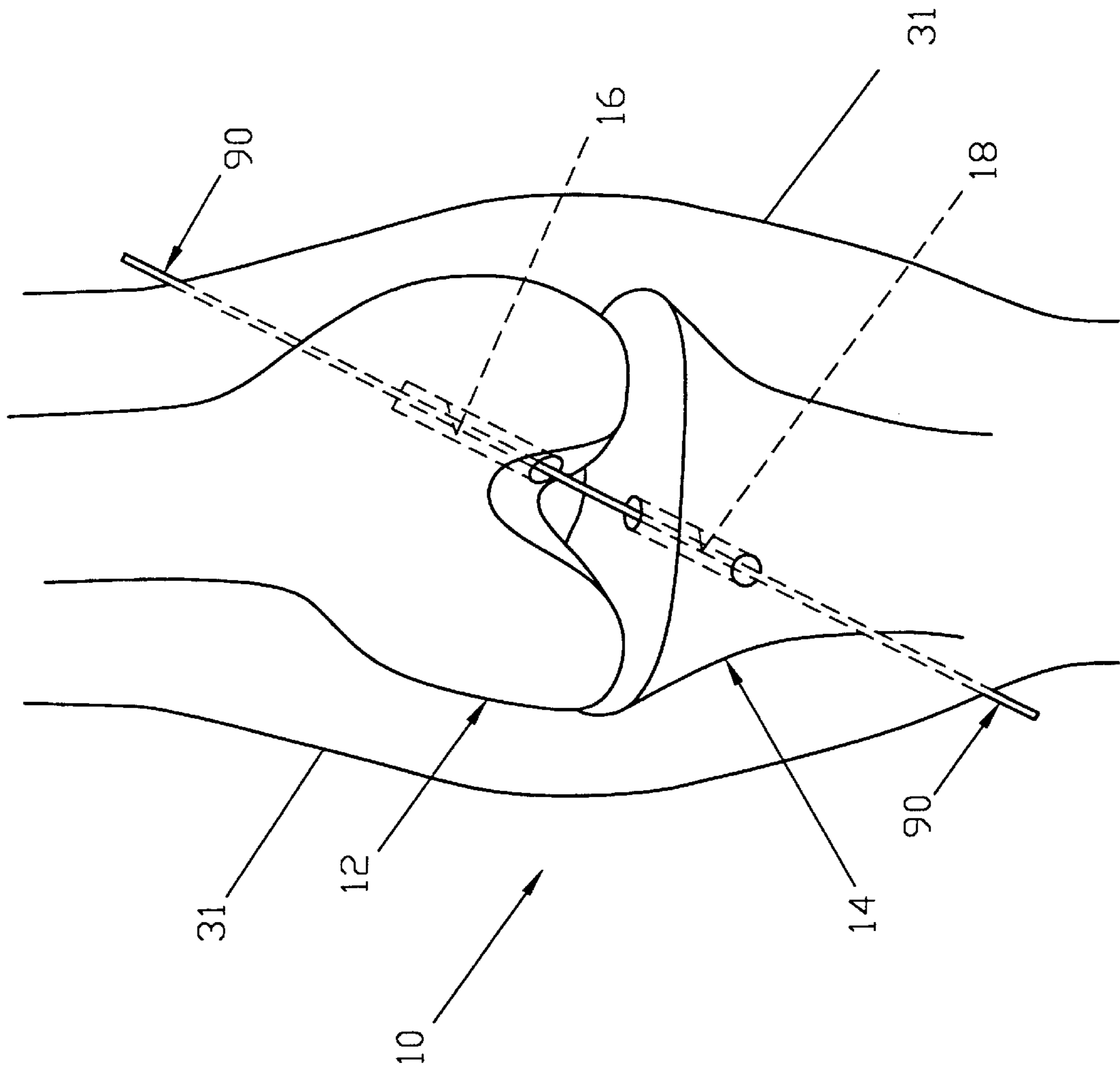

FIG. 34

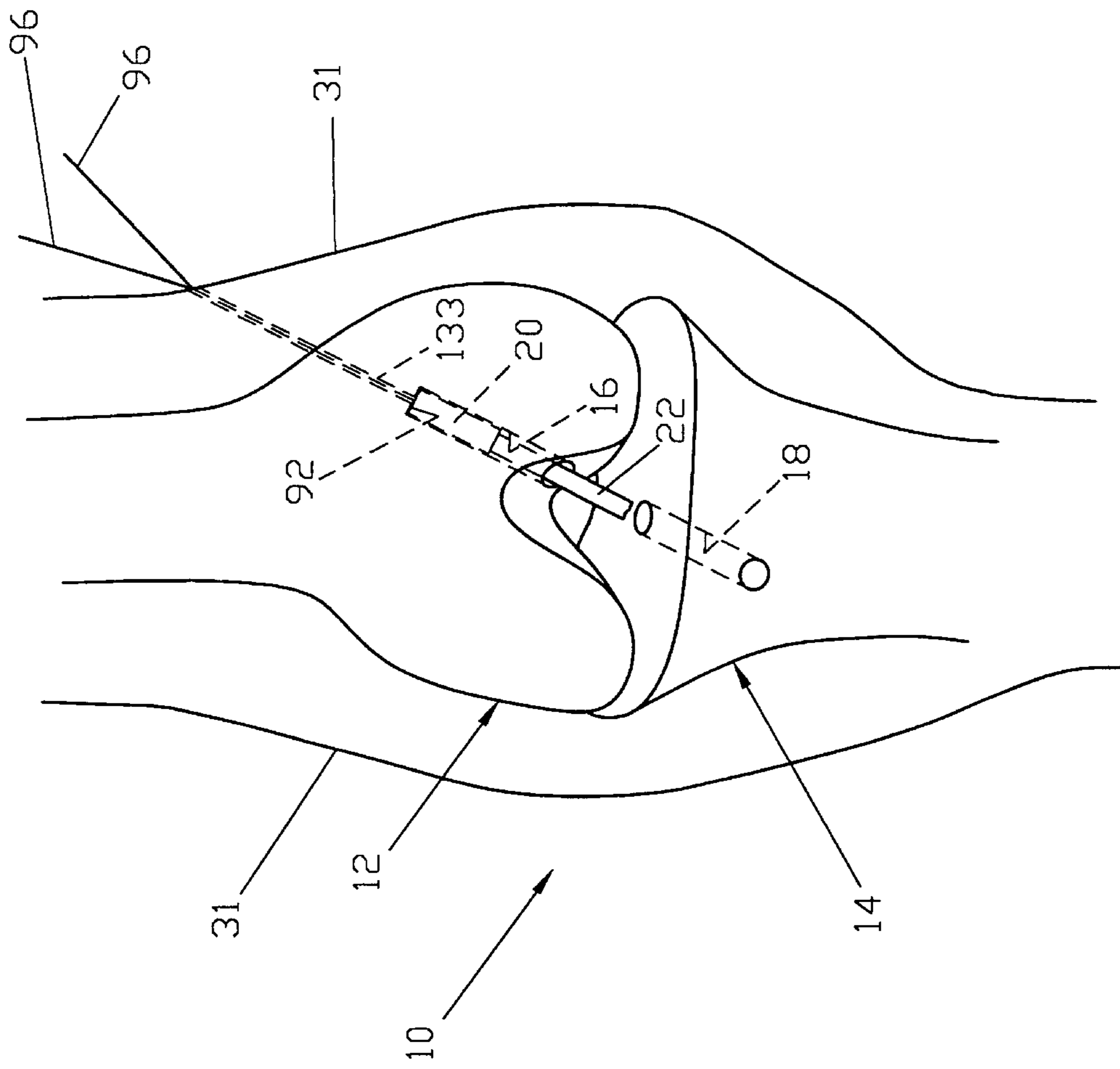

FIG. 35

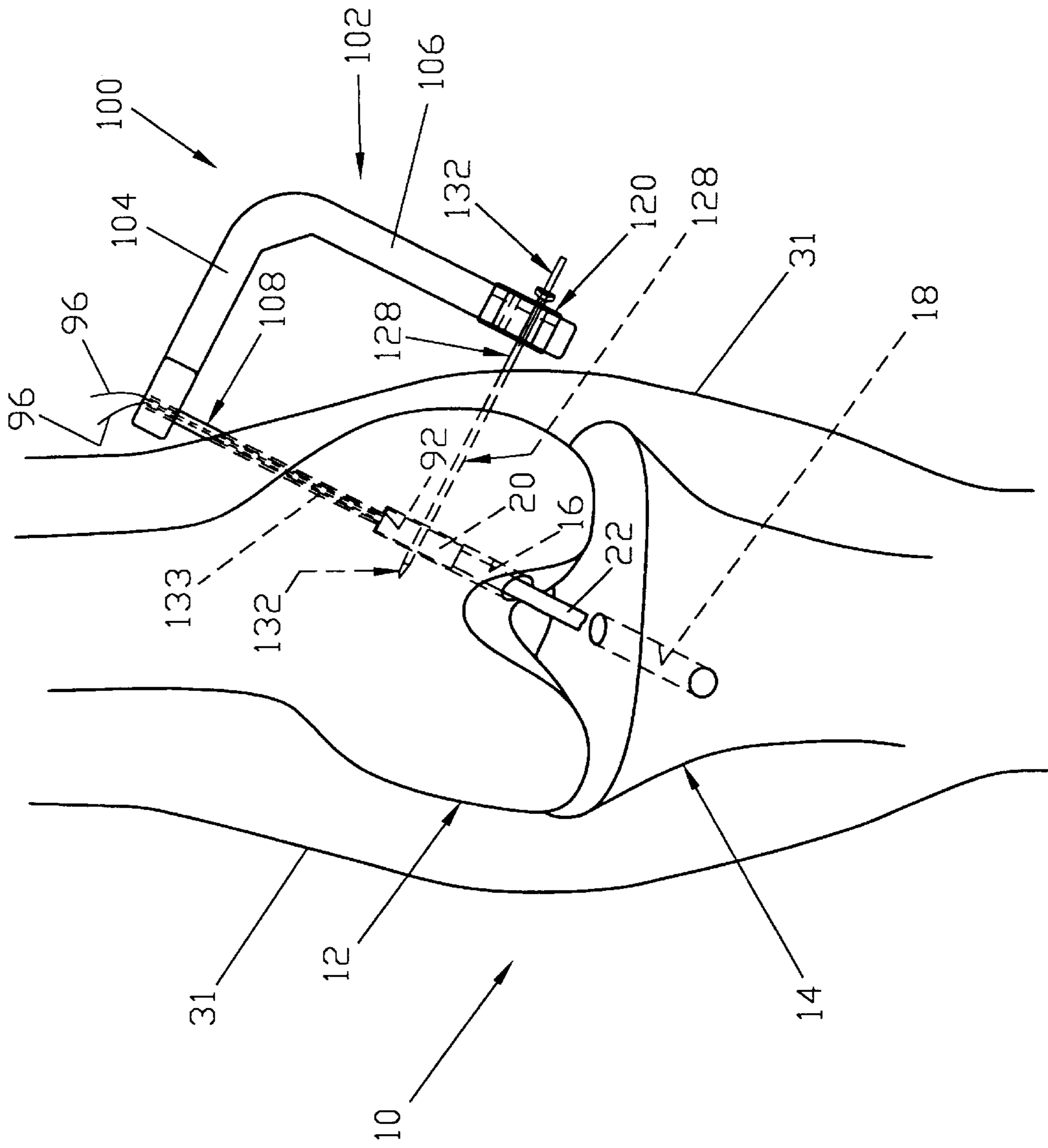

FIG. 36

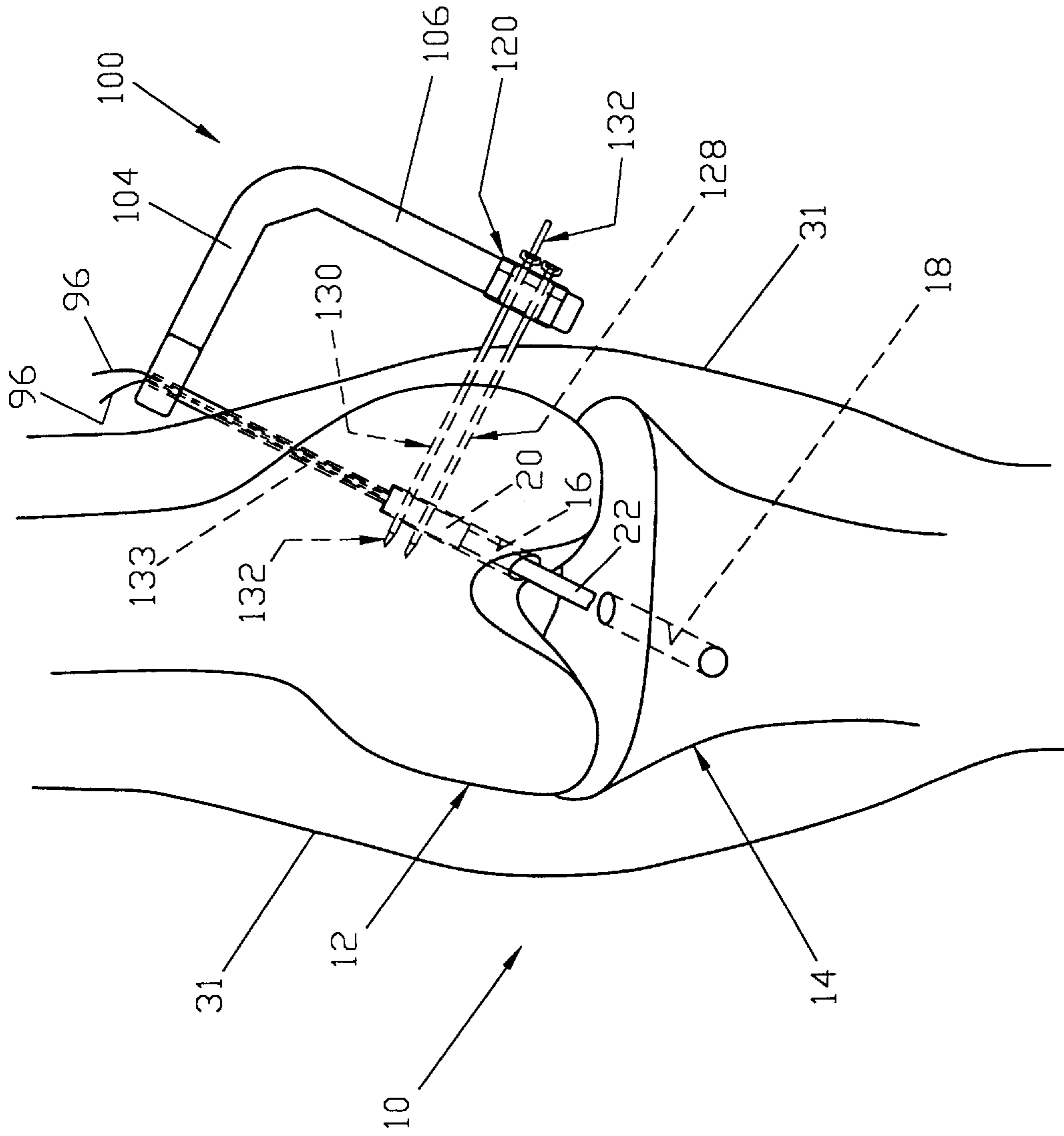

FIG. 37

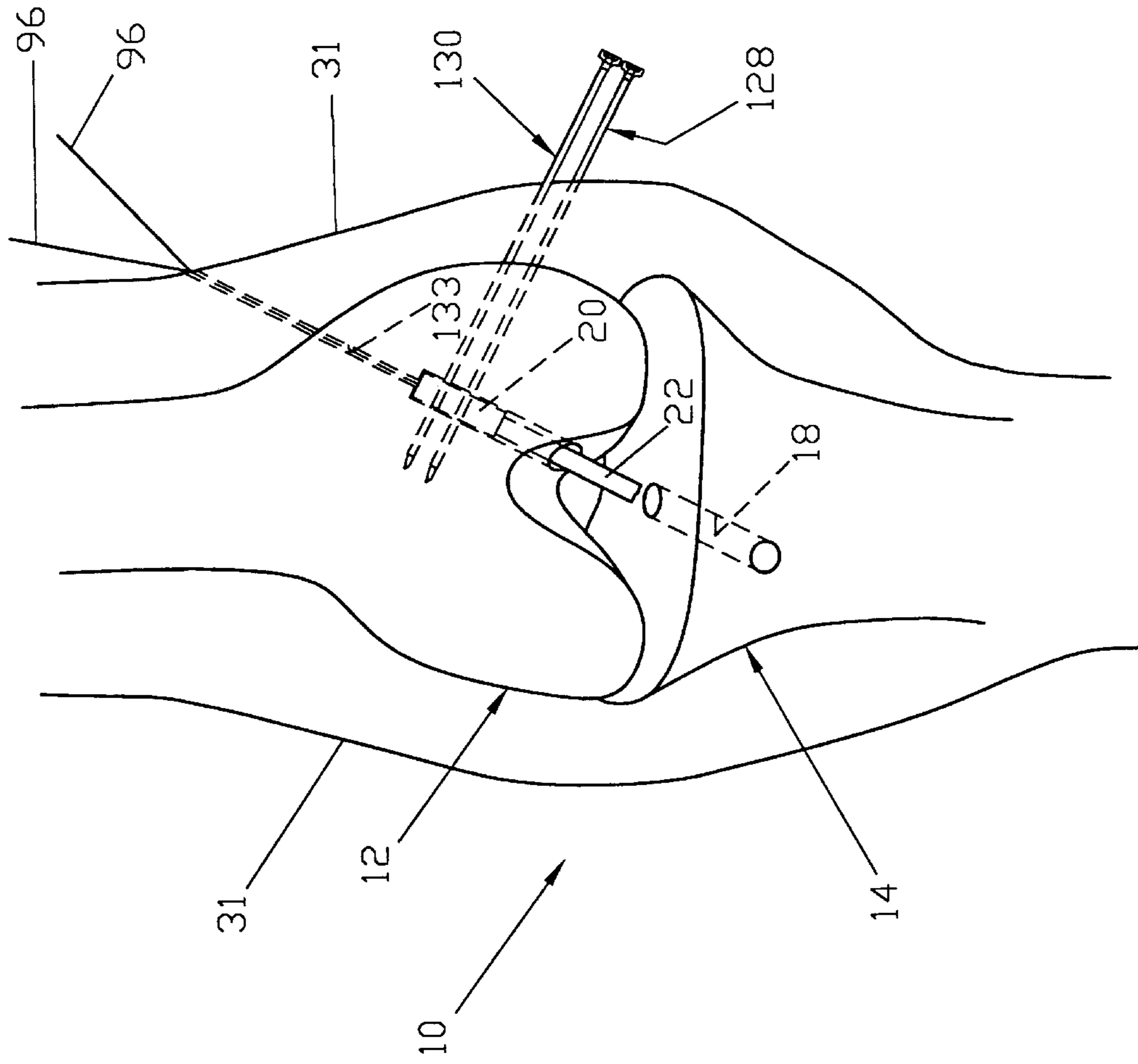

FIG. 38

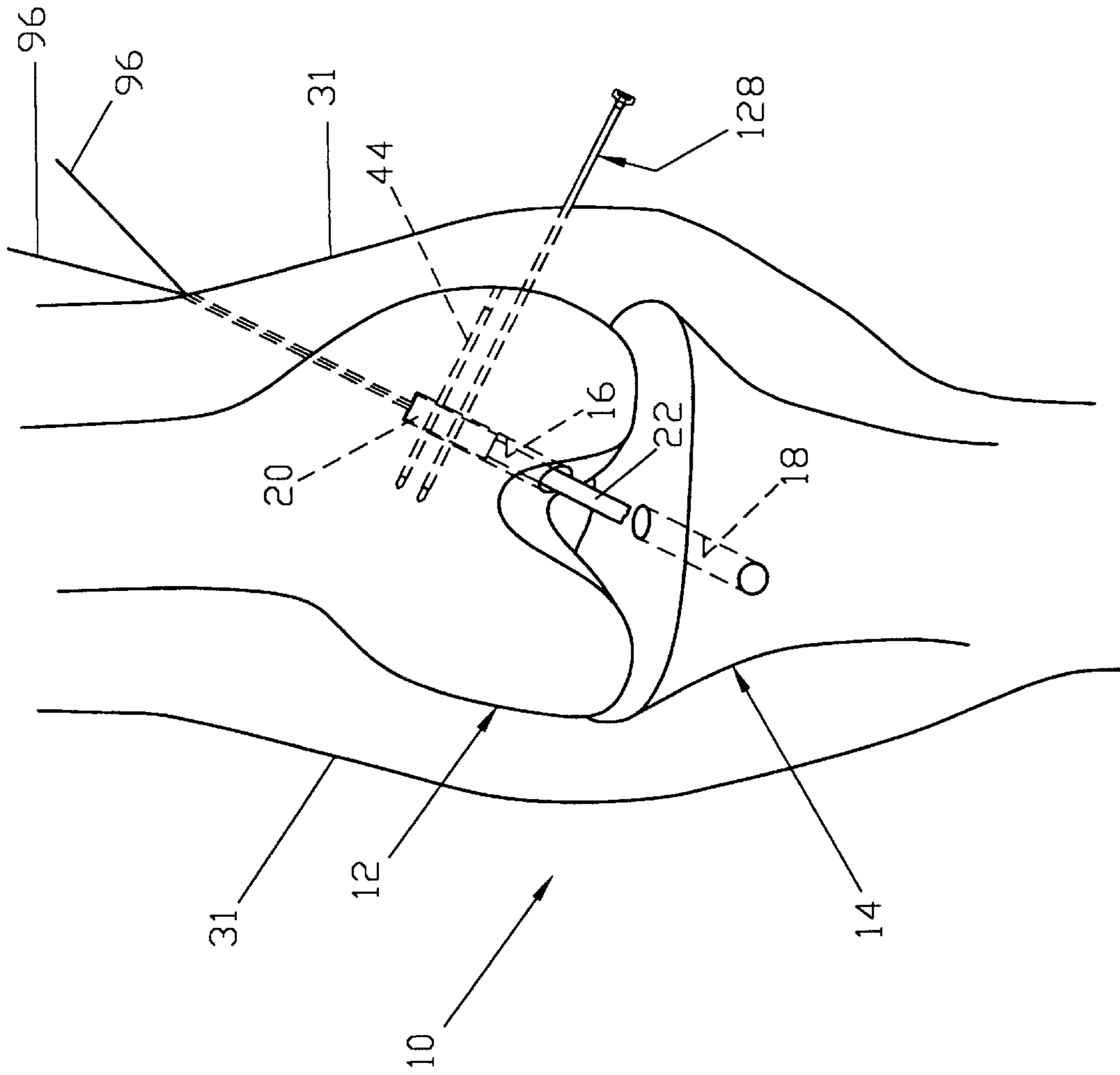

FIG. 39

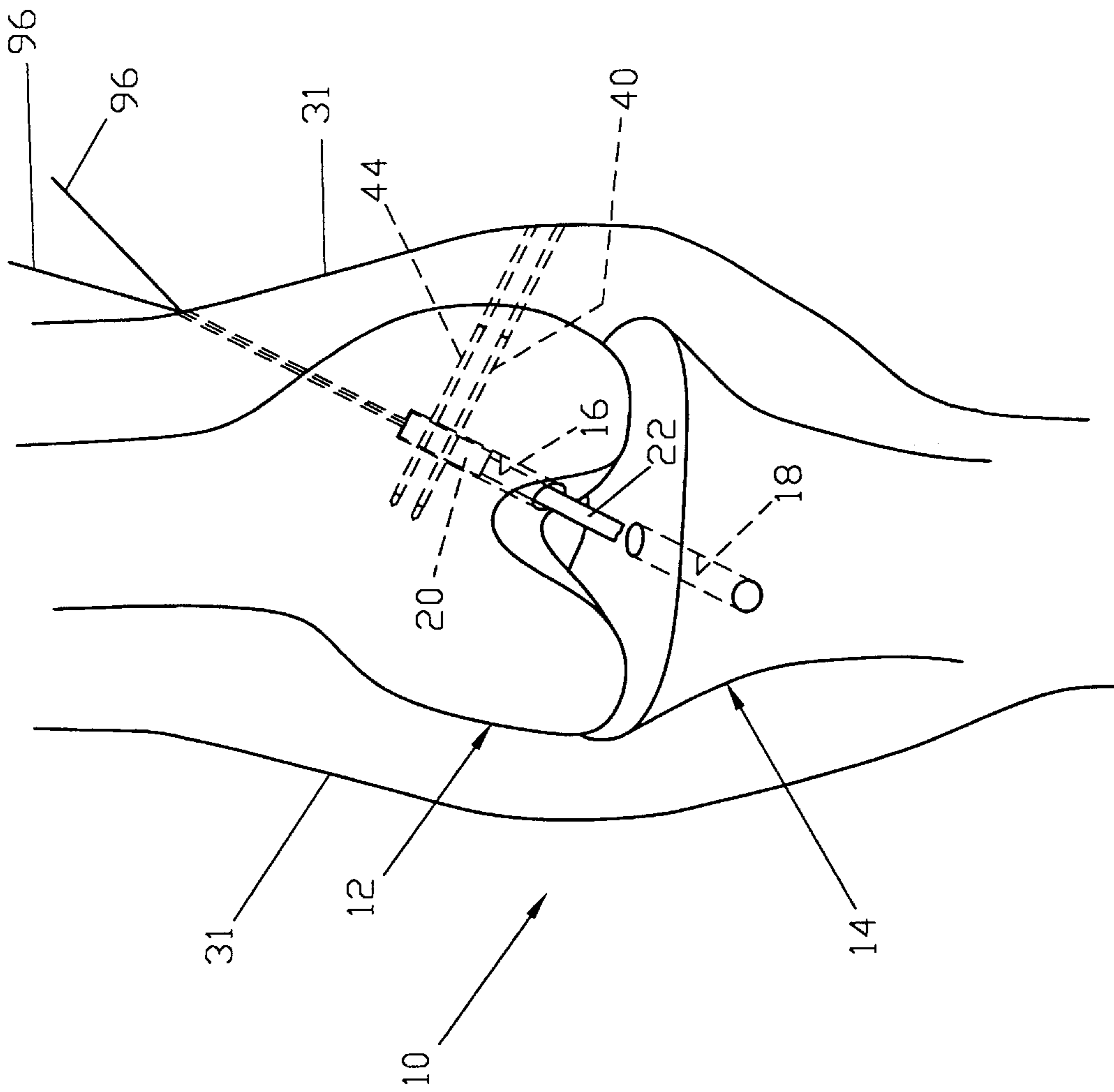

FIG. 40

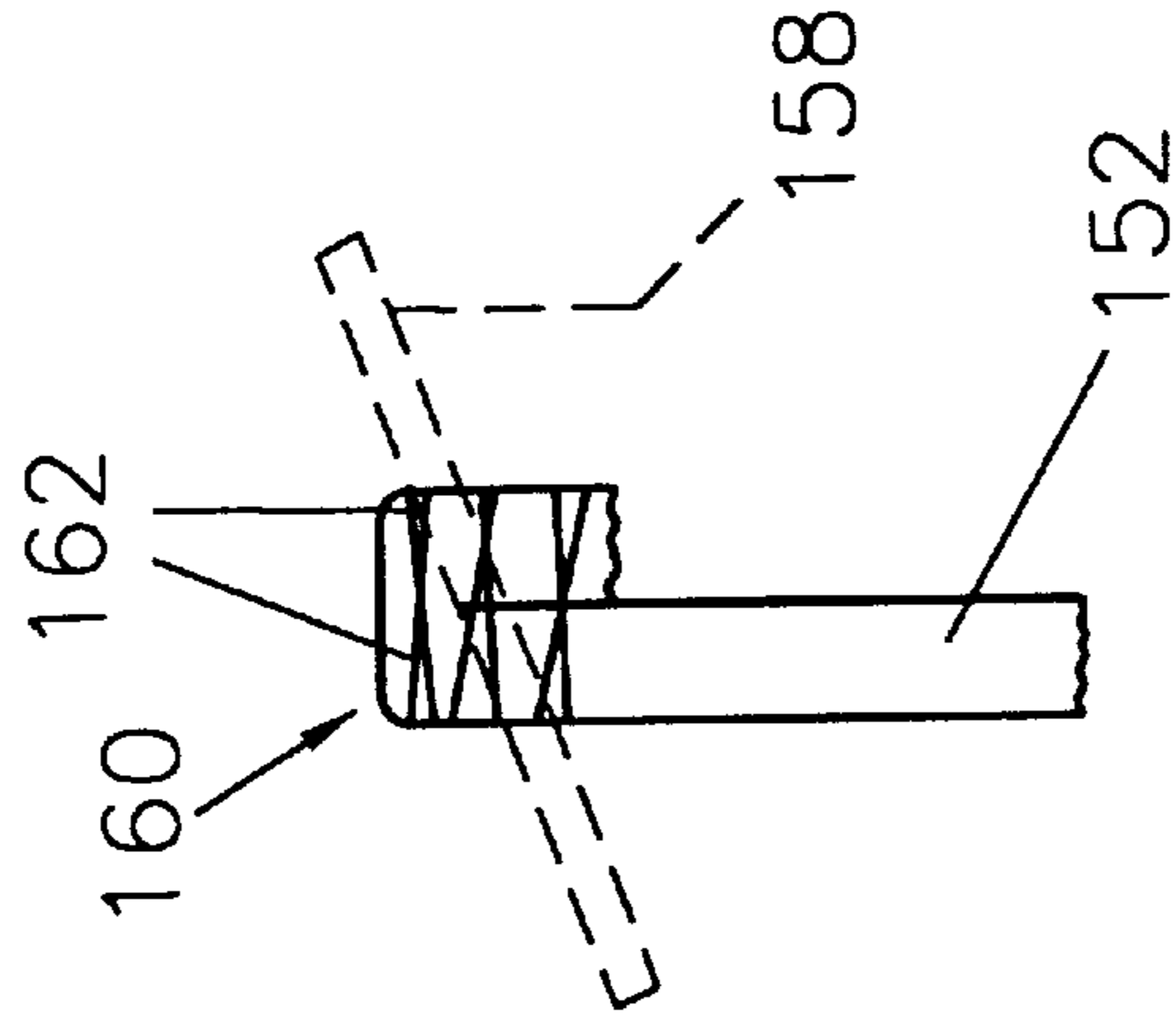

FIG. 43

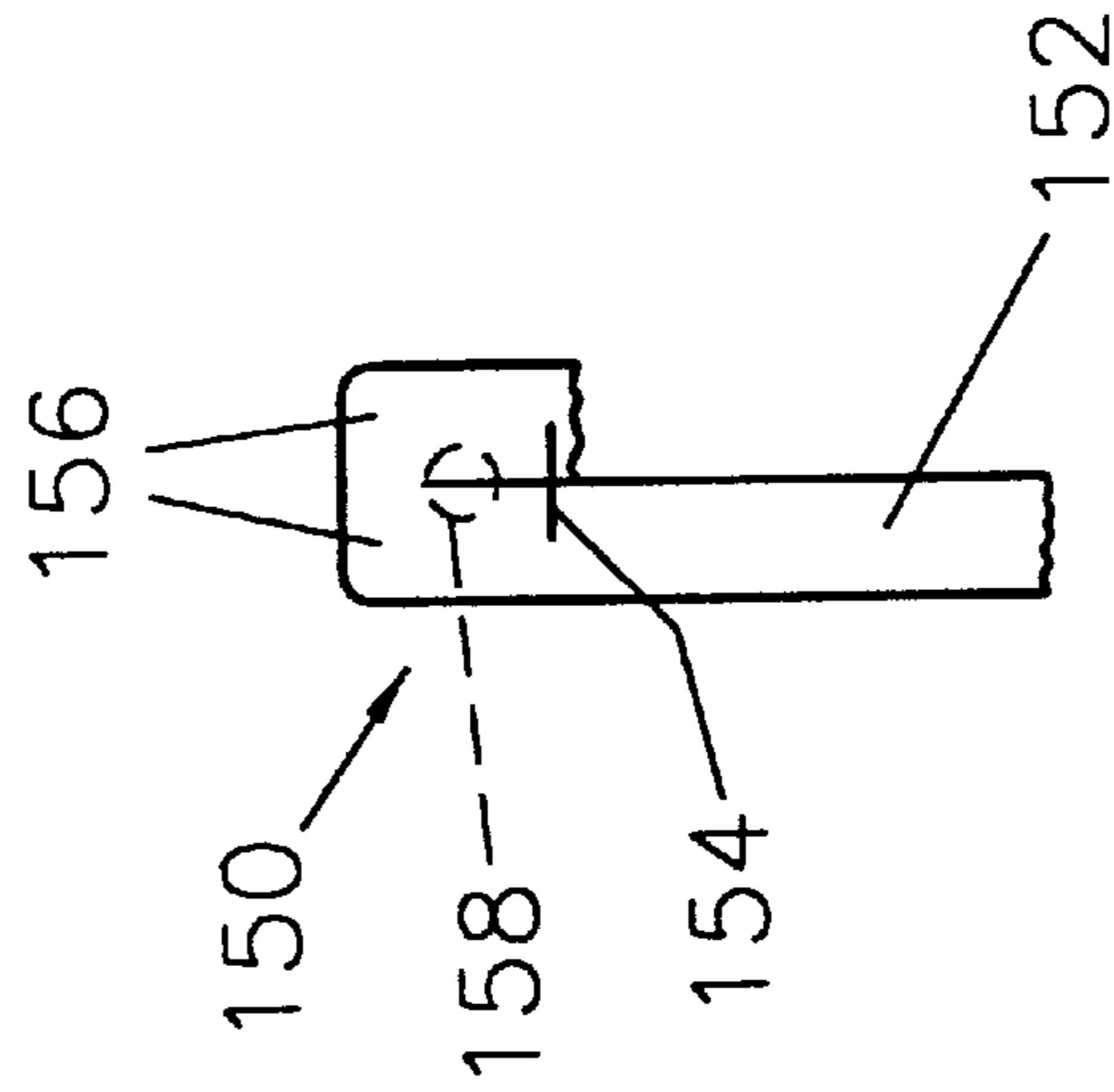

FIG. 42

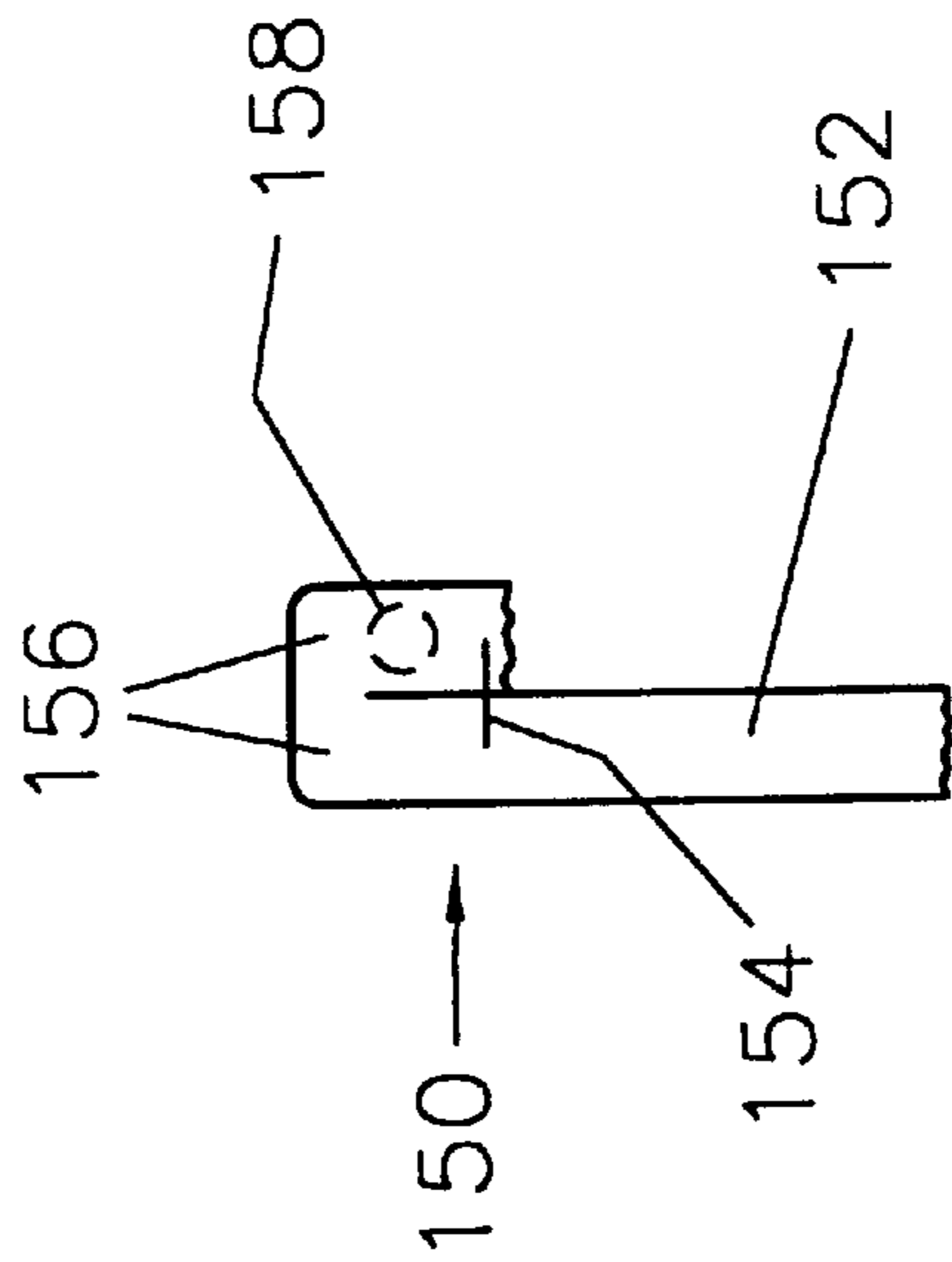

FIG. 41

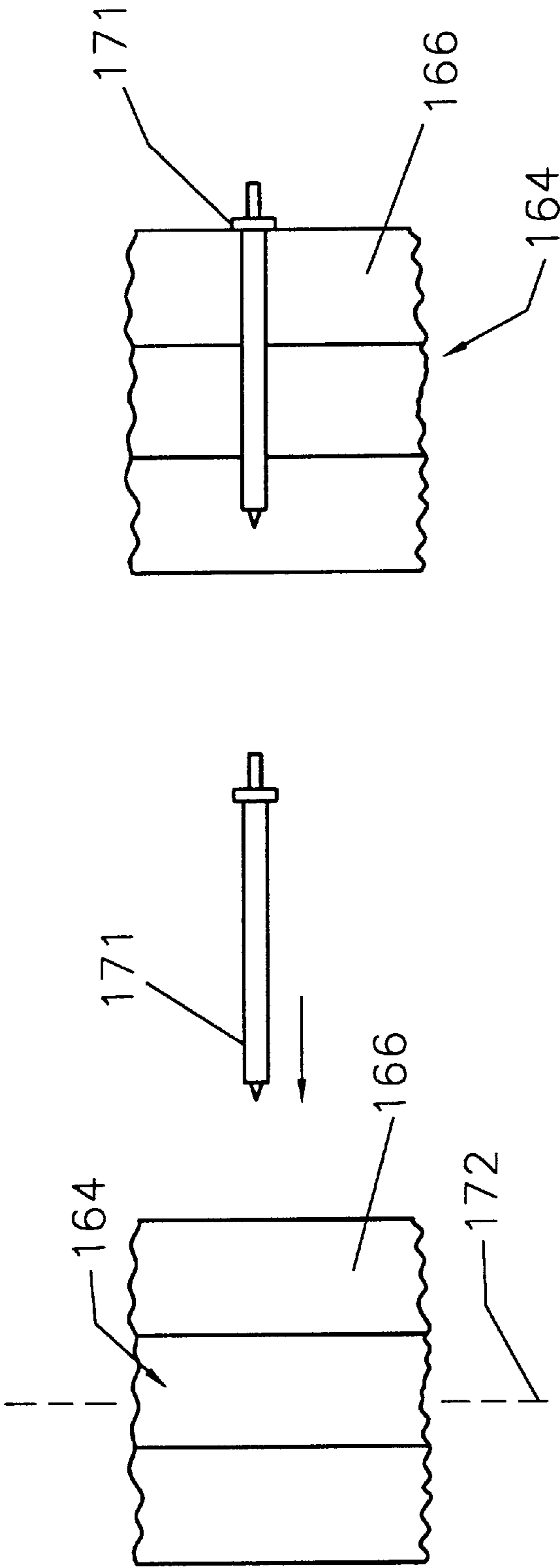

FIG. 45

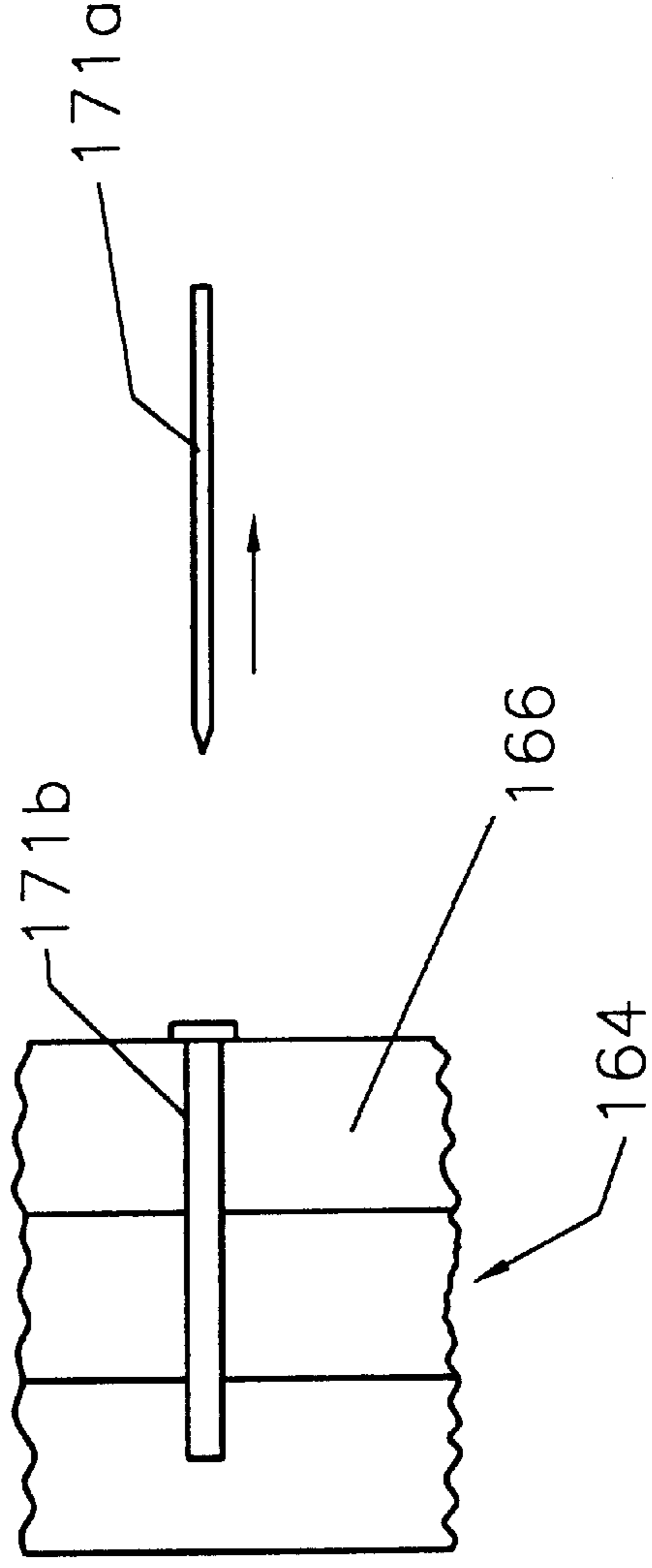

FIG. 46

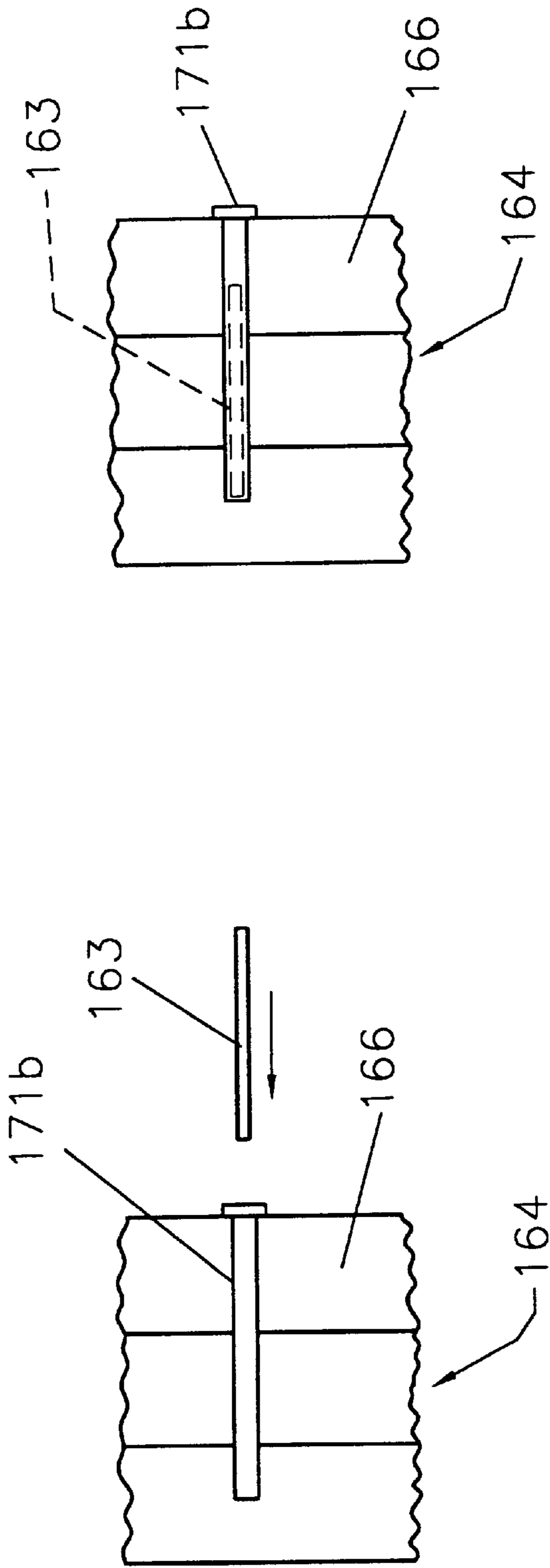

FIG. 48

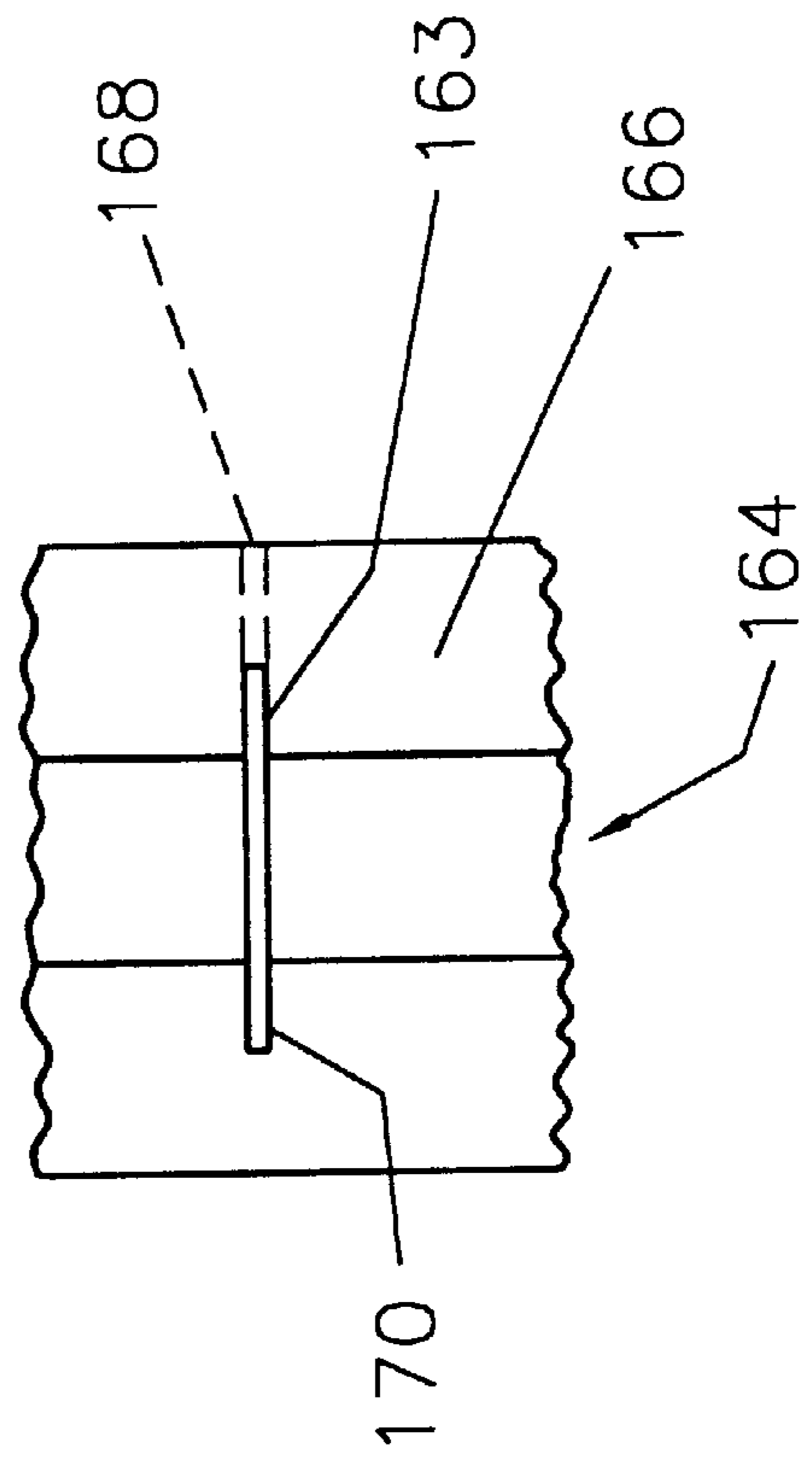

FIG. 49

FIG. 47

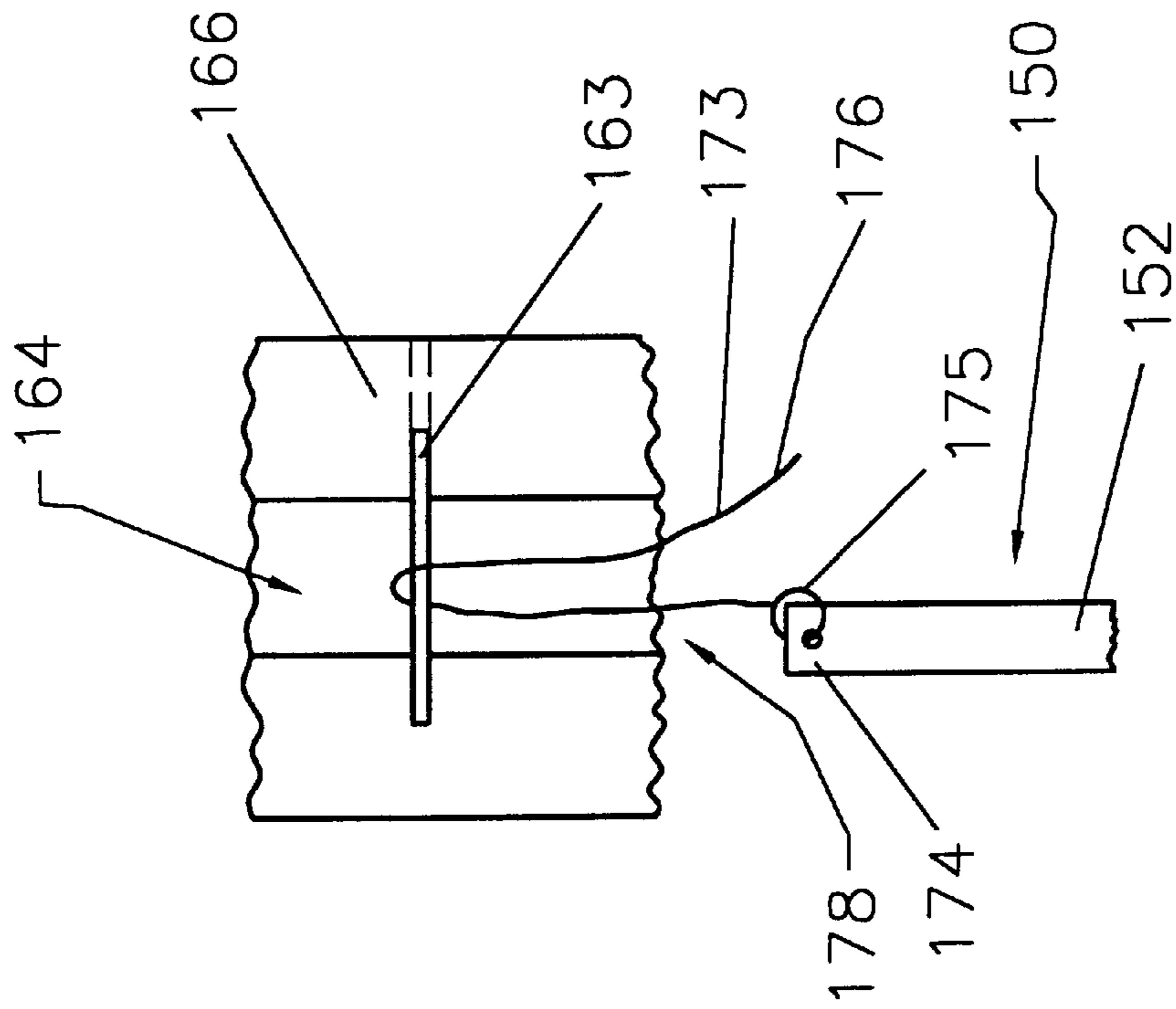

FIG. 50

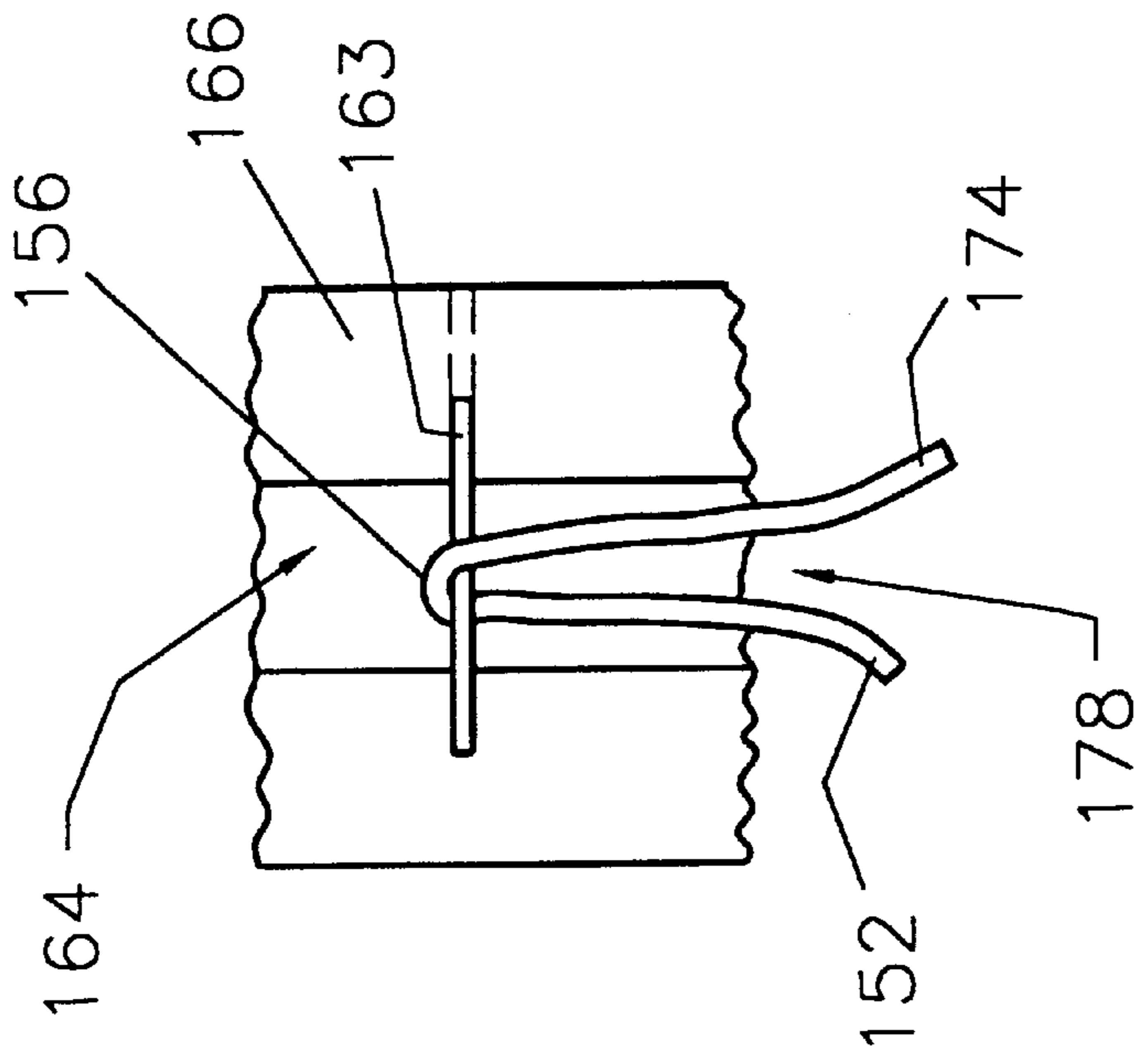

FIG. 51

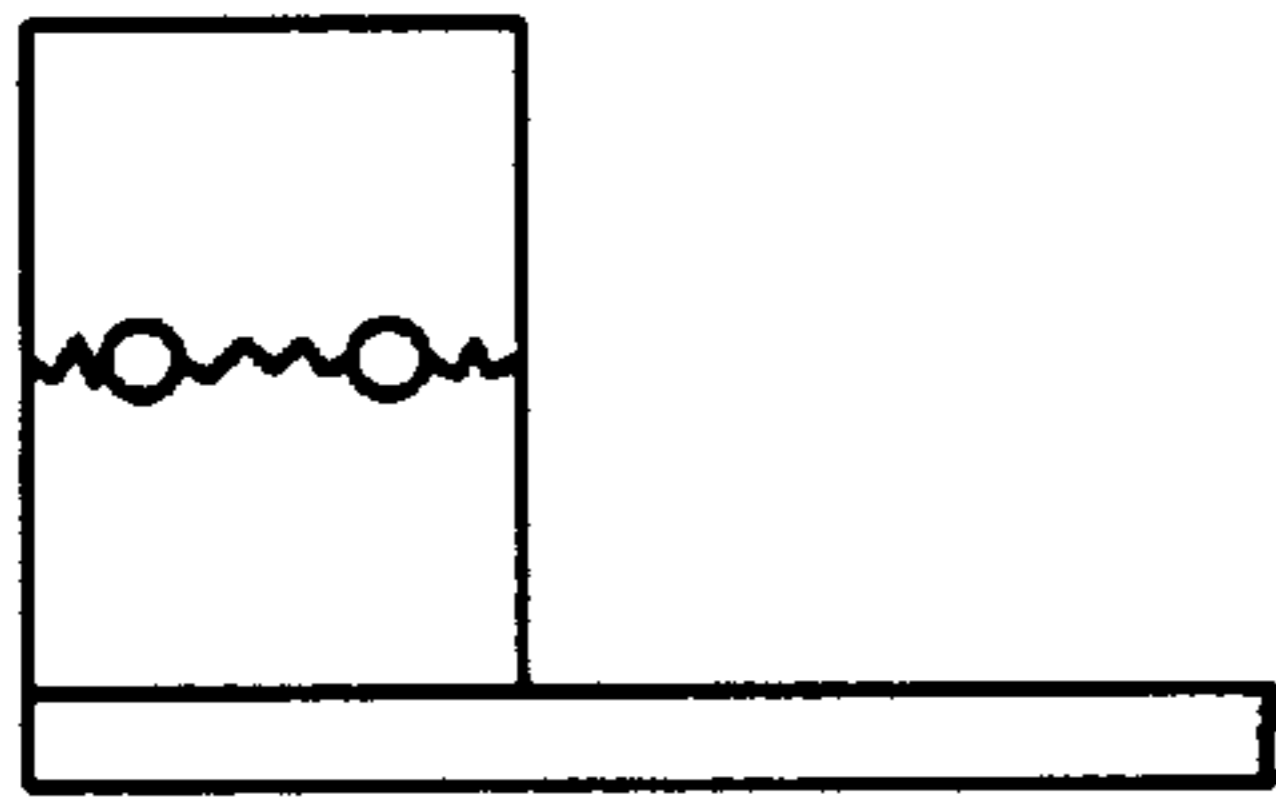

FIG. 52

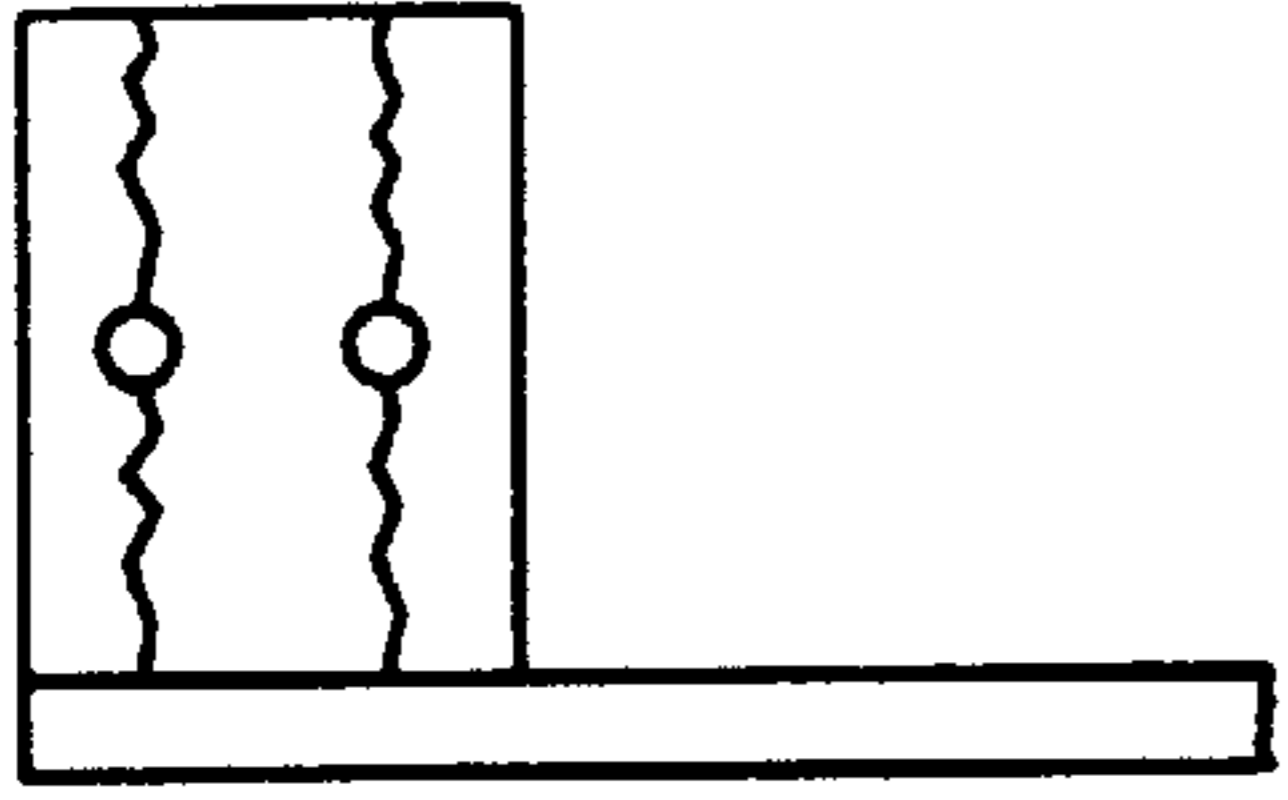

FIG. 53

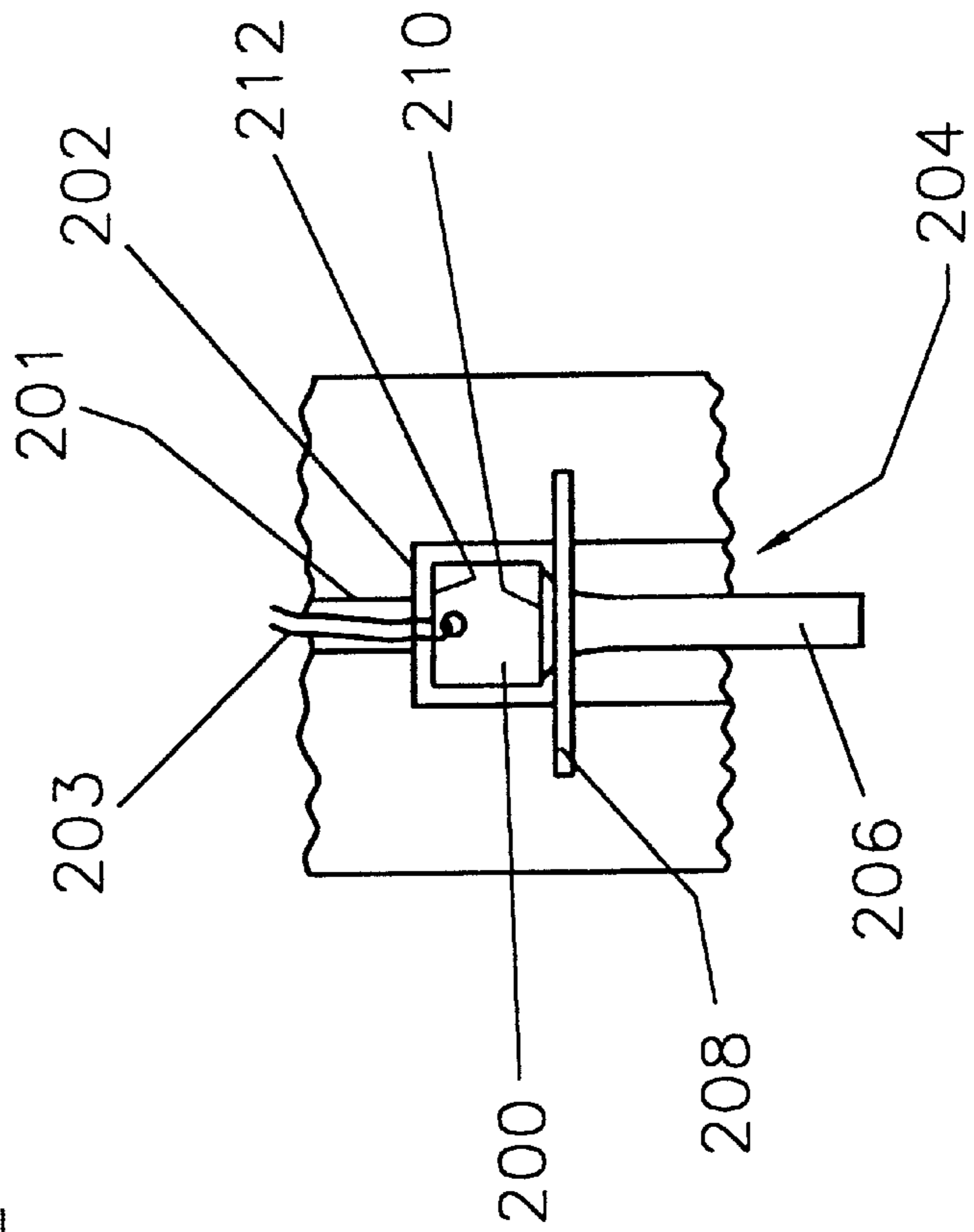

FIG. 54

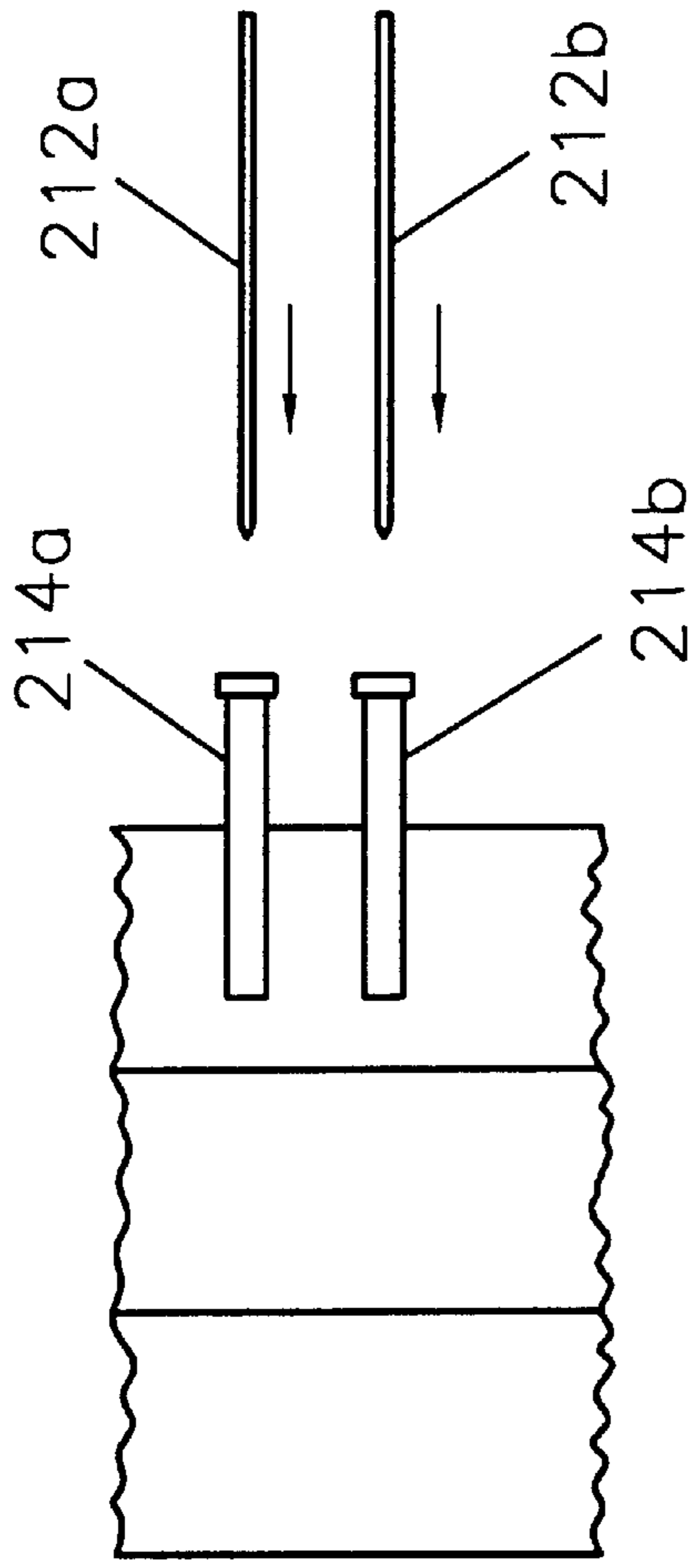

FIG. 56

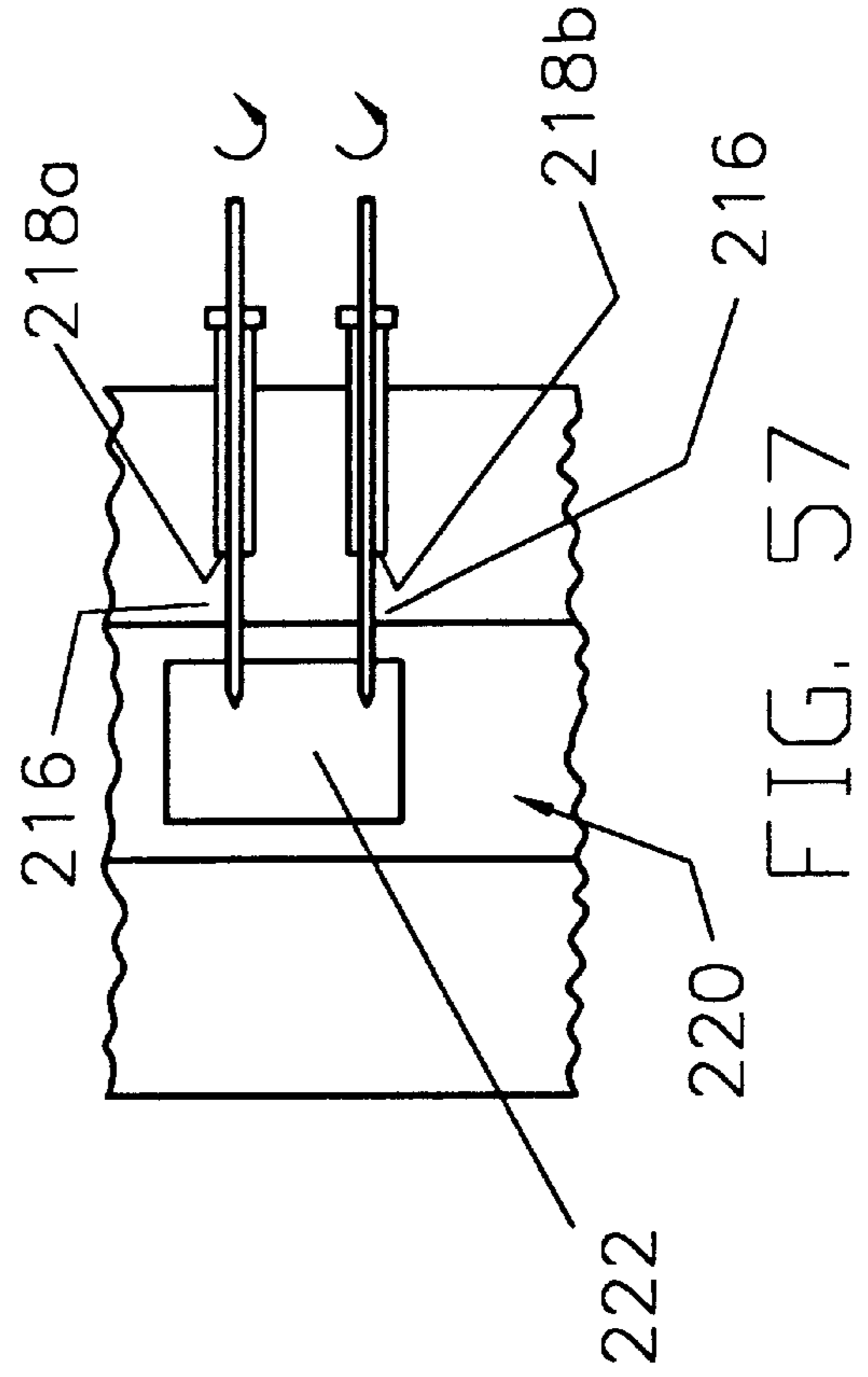

FIG. 57

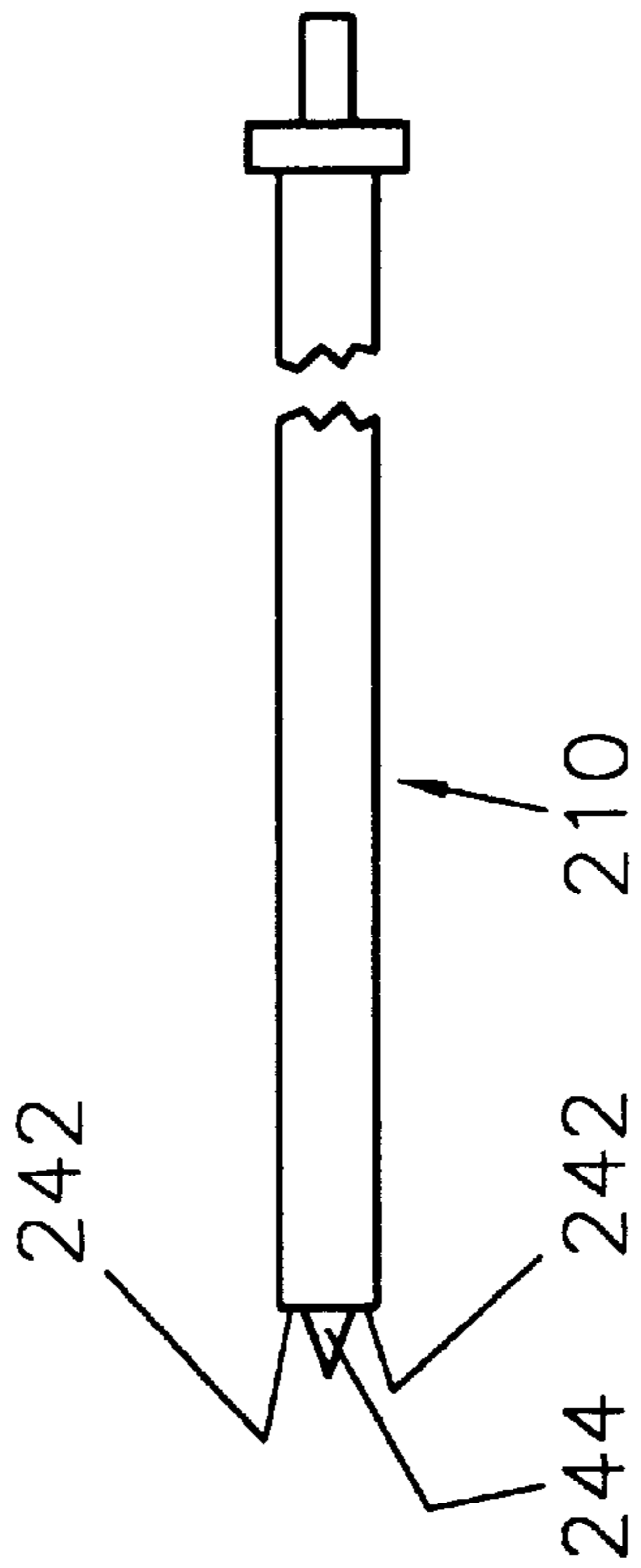

FIG. 55

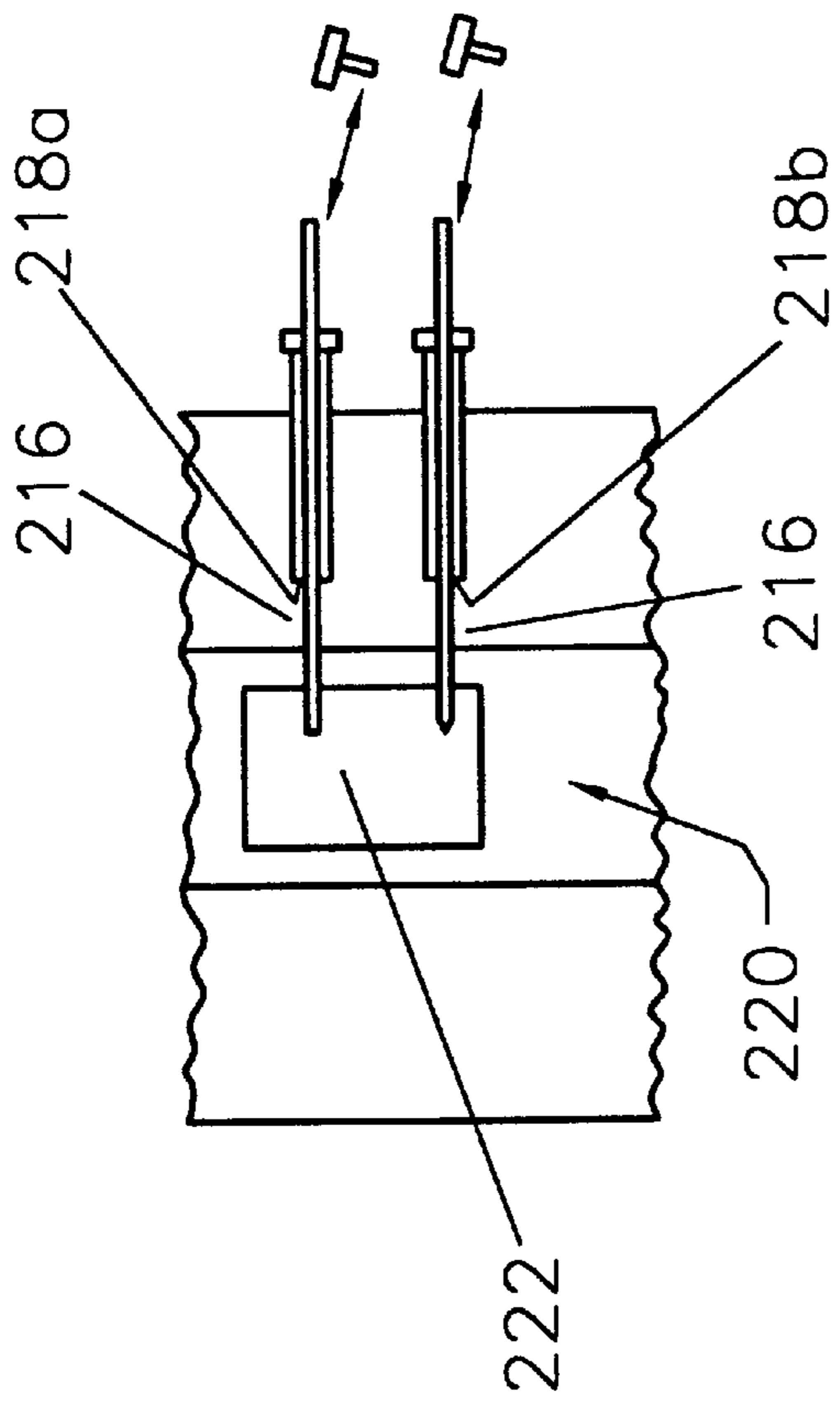

FIG. 58

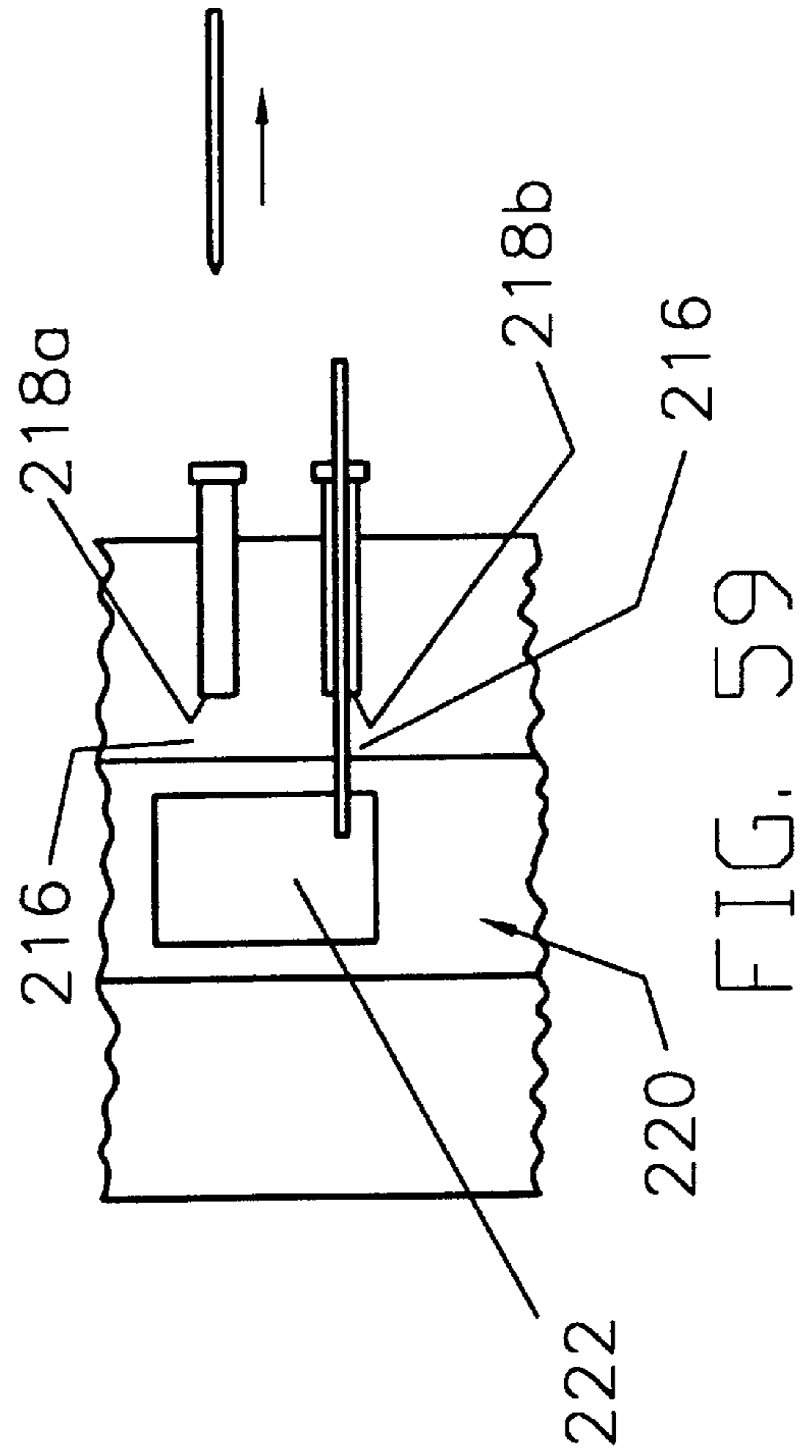

FIG. 59

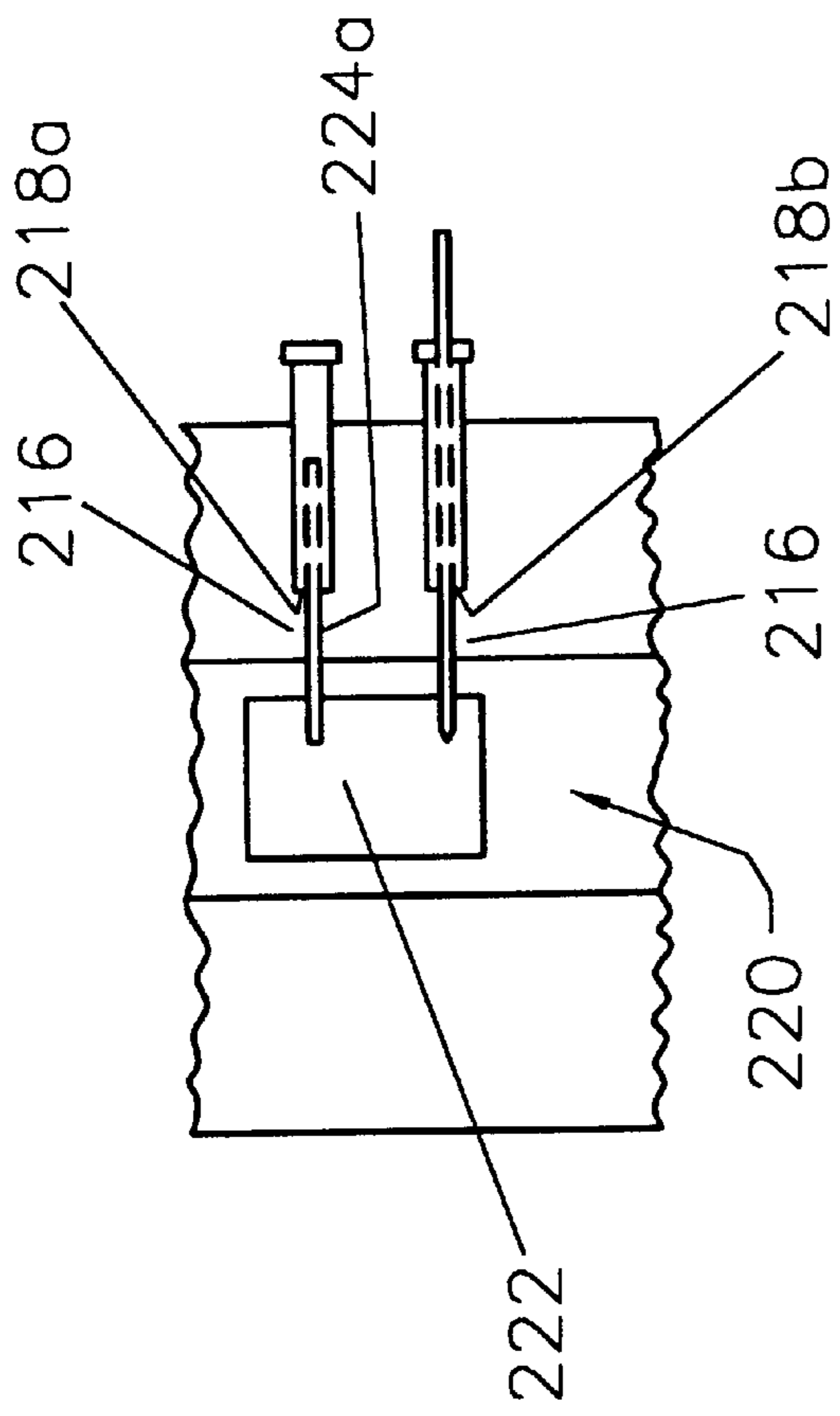

FIG. 60

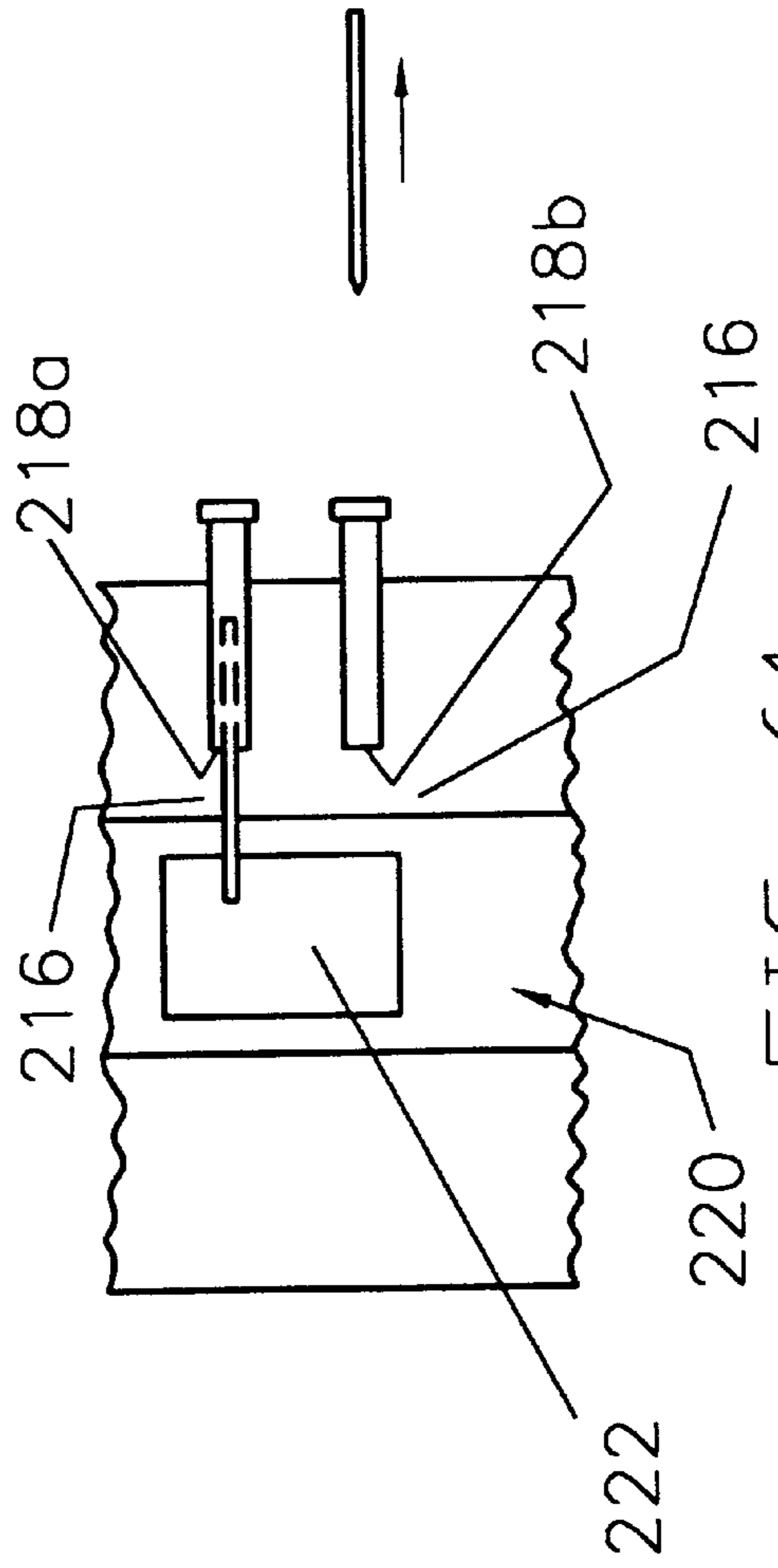

FIG. 61

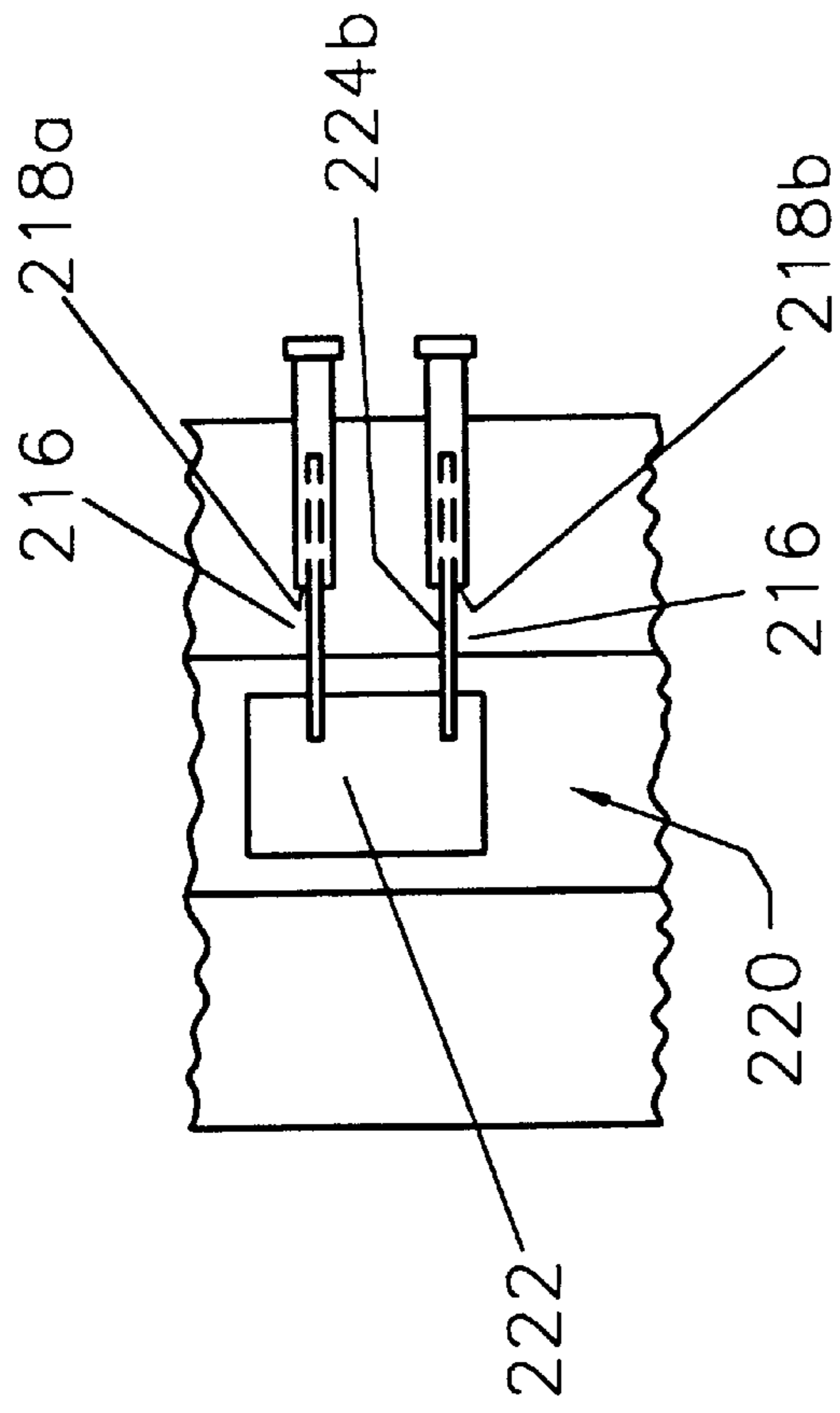

FIG. 62

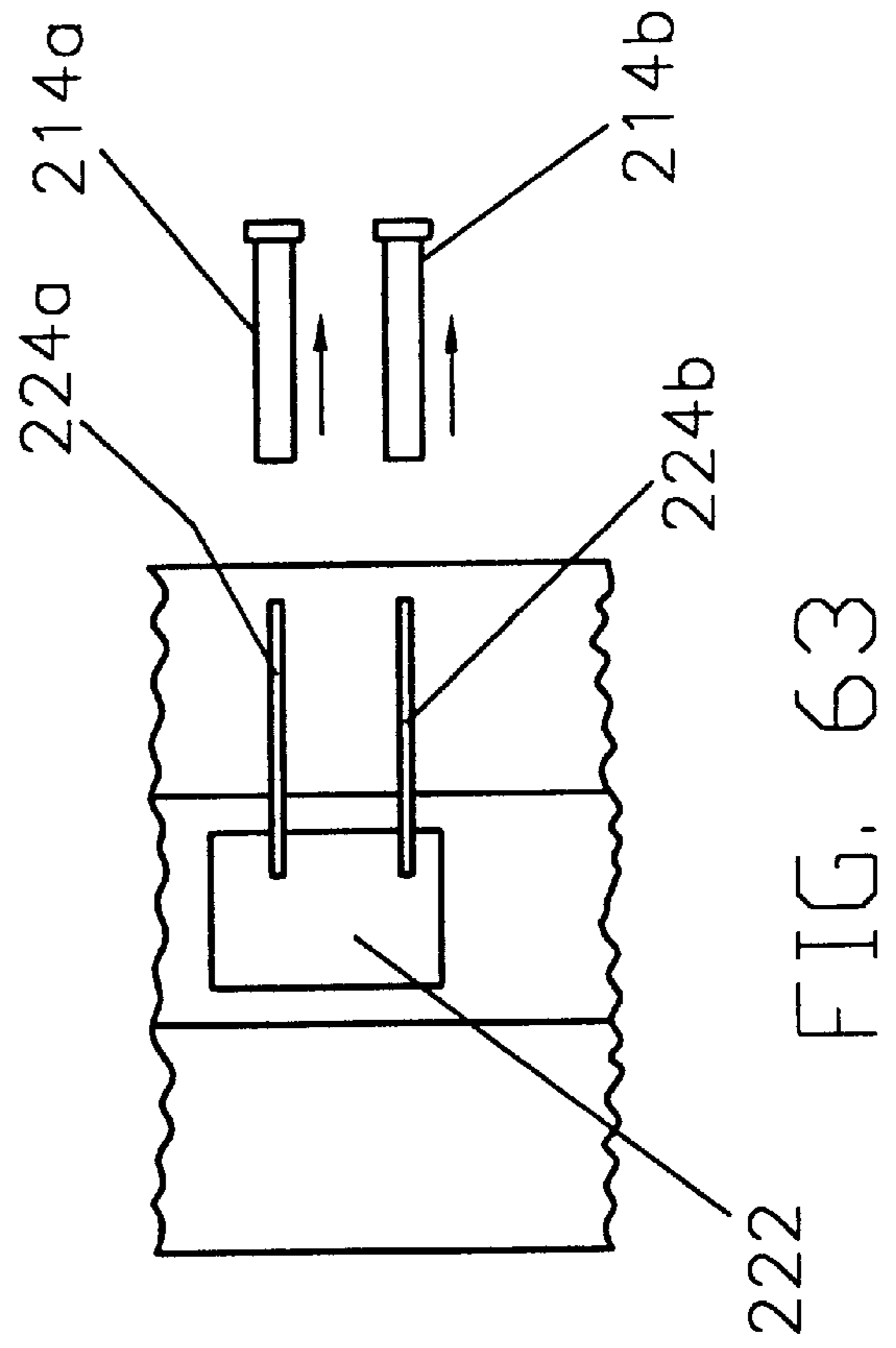

FIG. 63

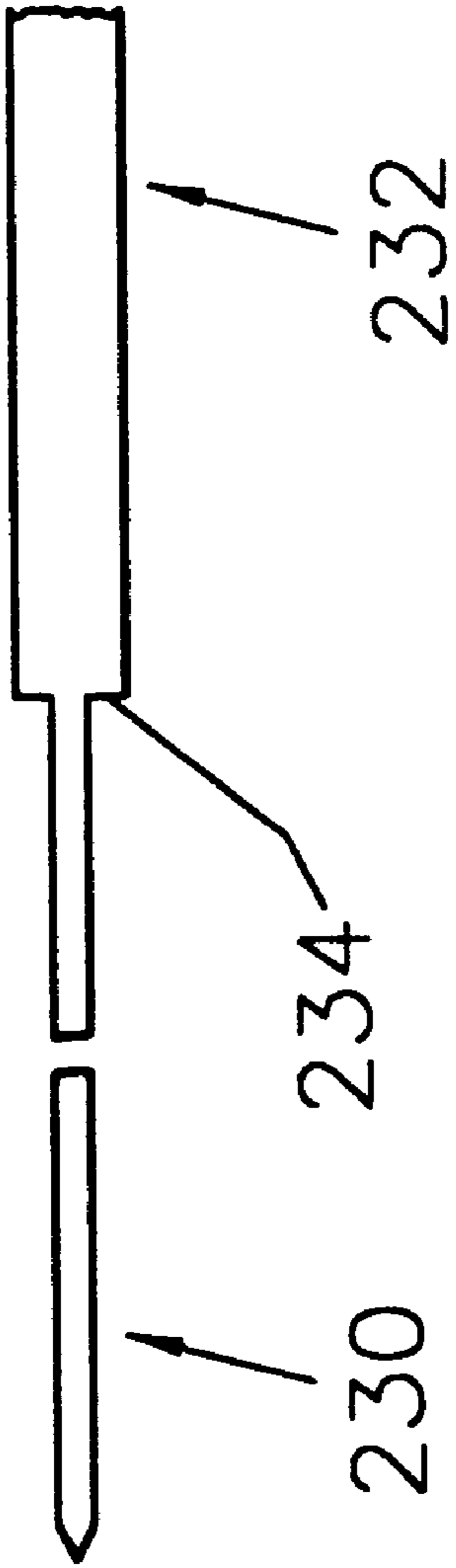

FIG. 64

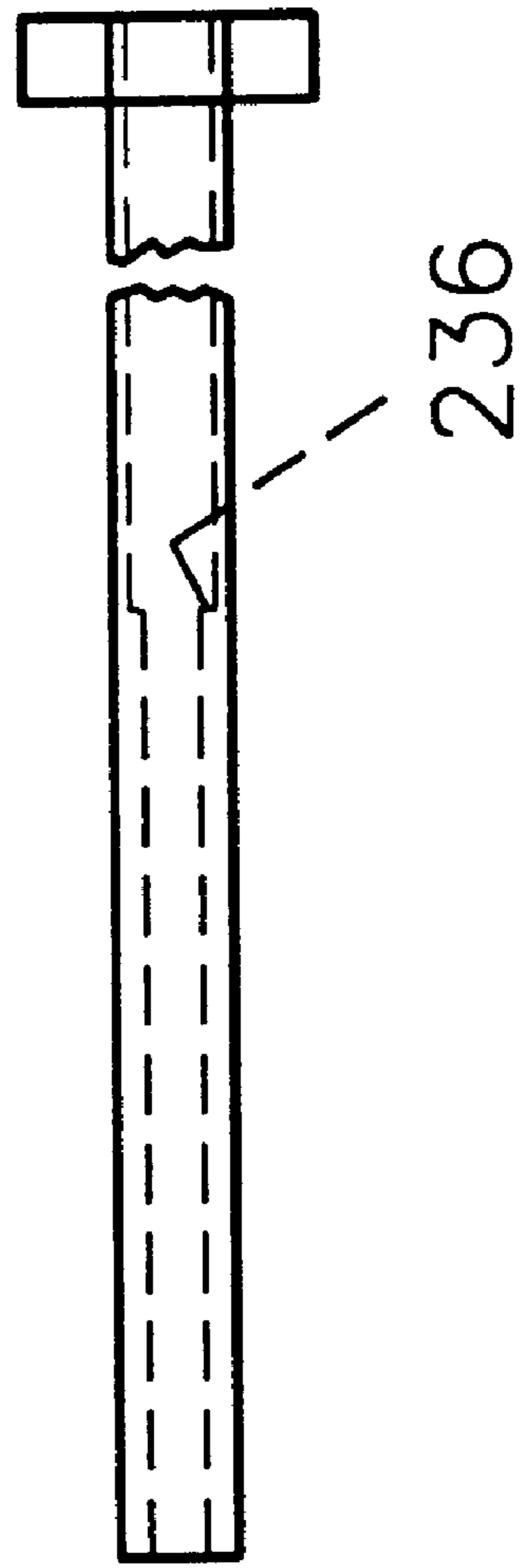

FIG. 65

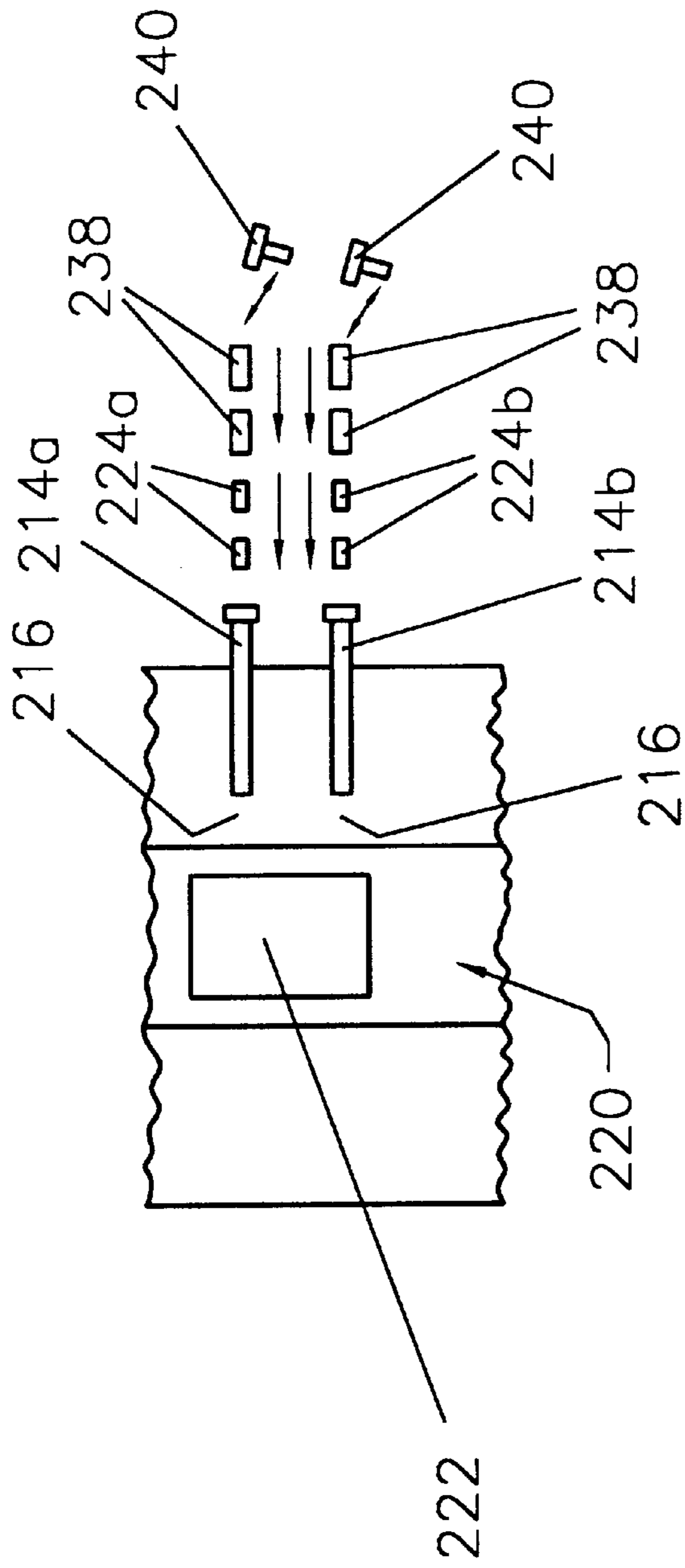

FIG. 66

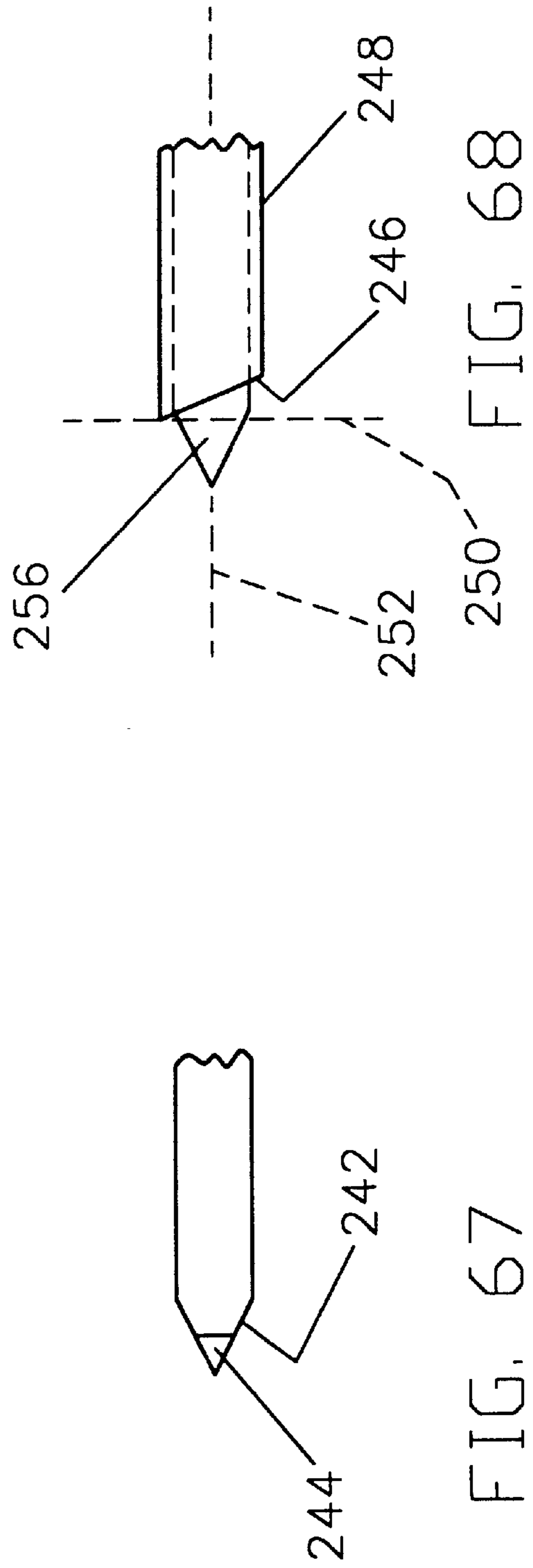

FIG. 67

FIG. 68

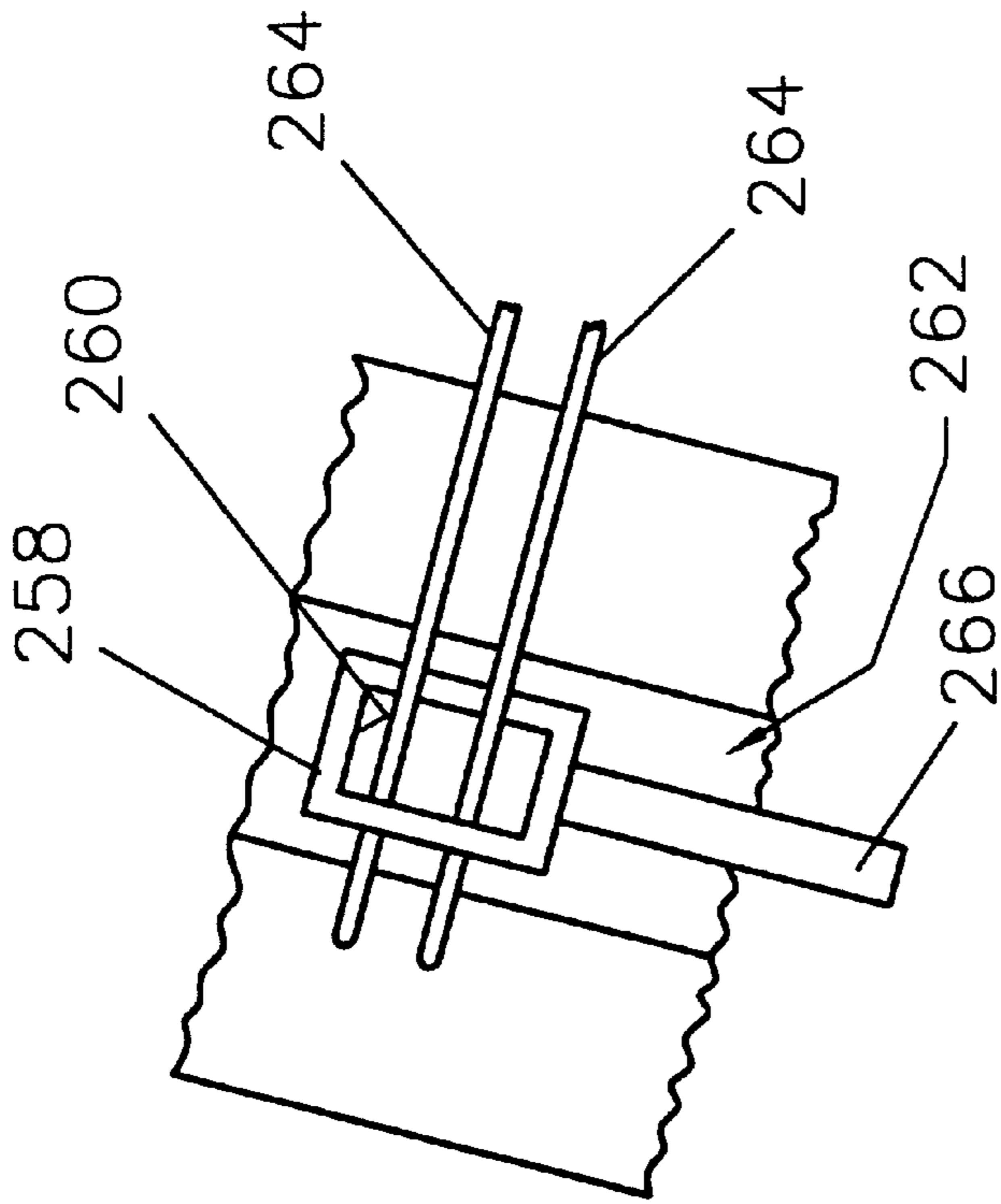

FIG. 69

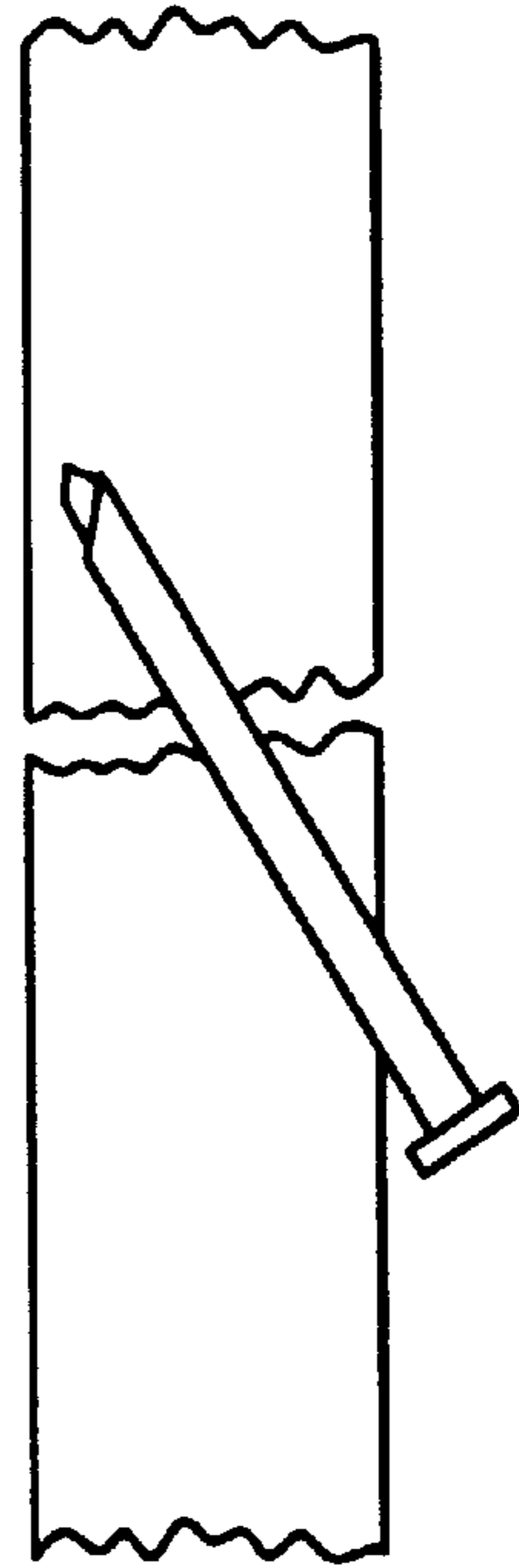

FIG. 71

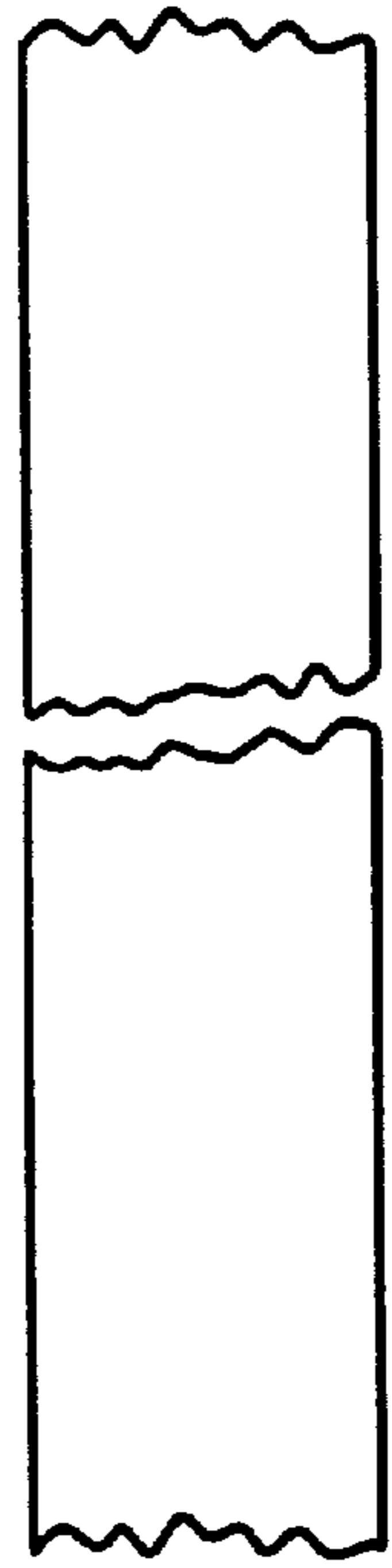

FIG. 70

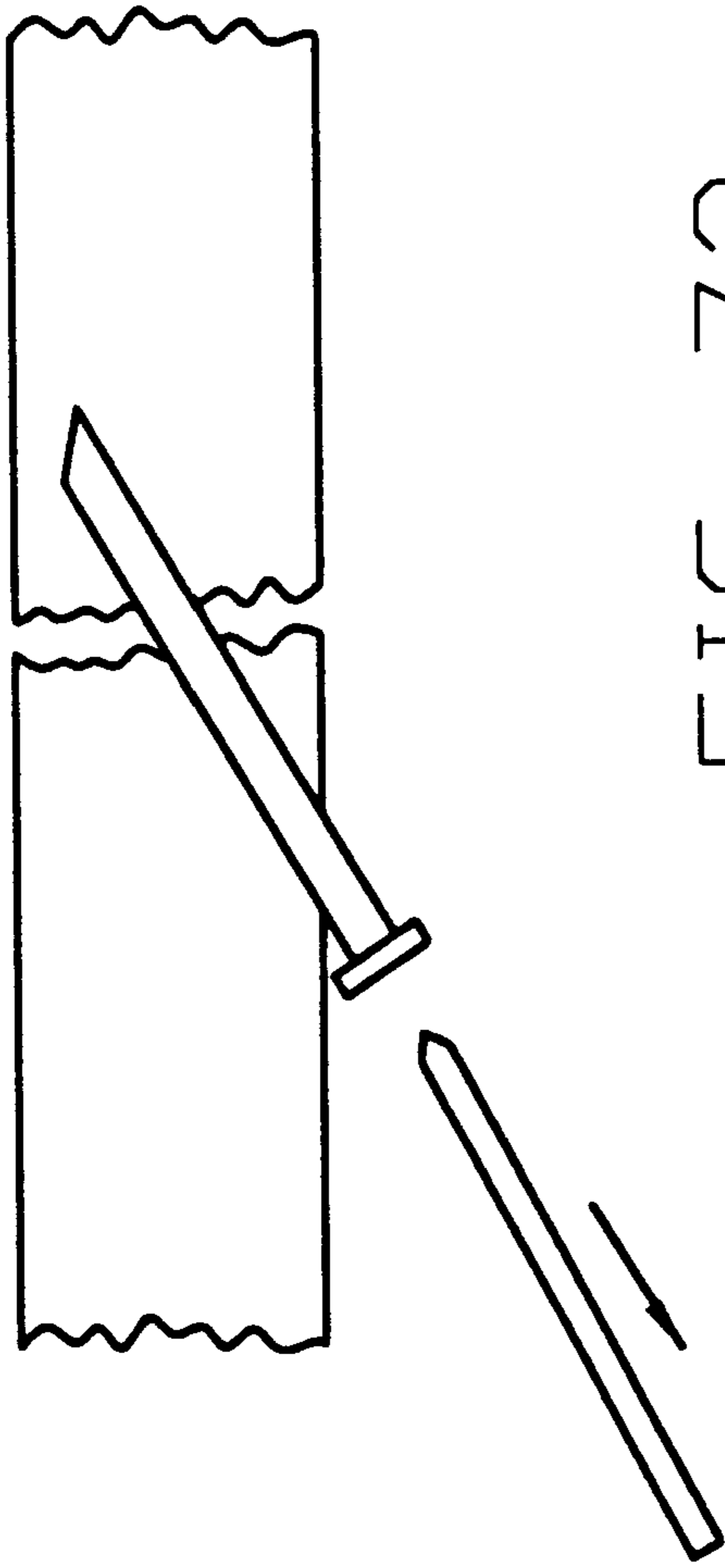

FIG. 72

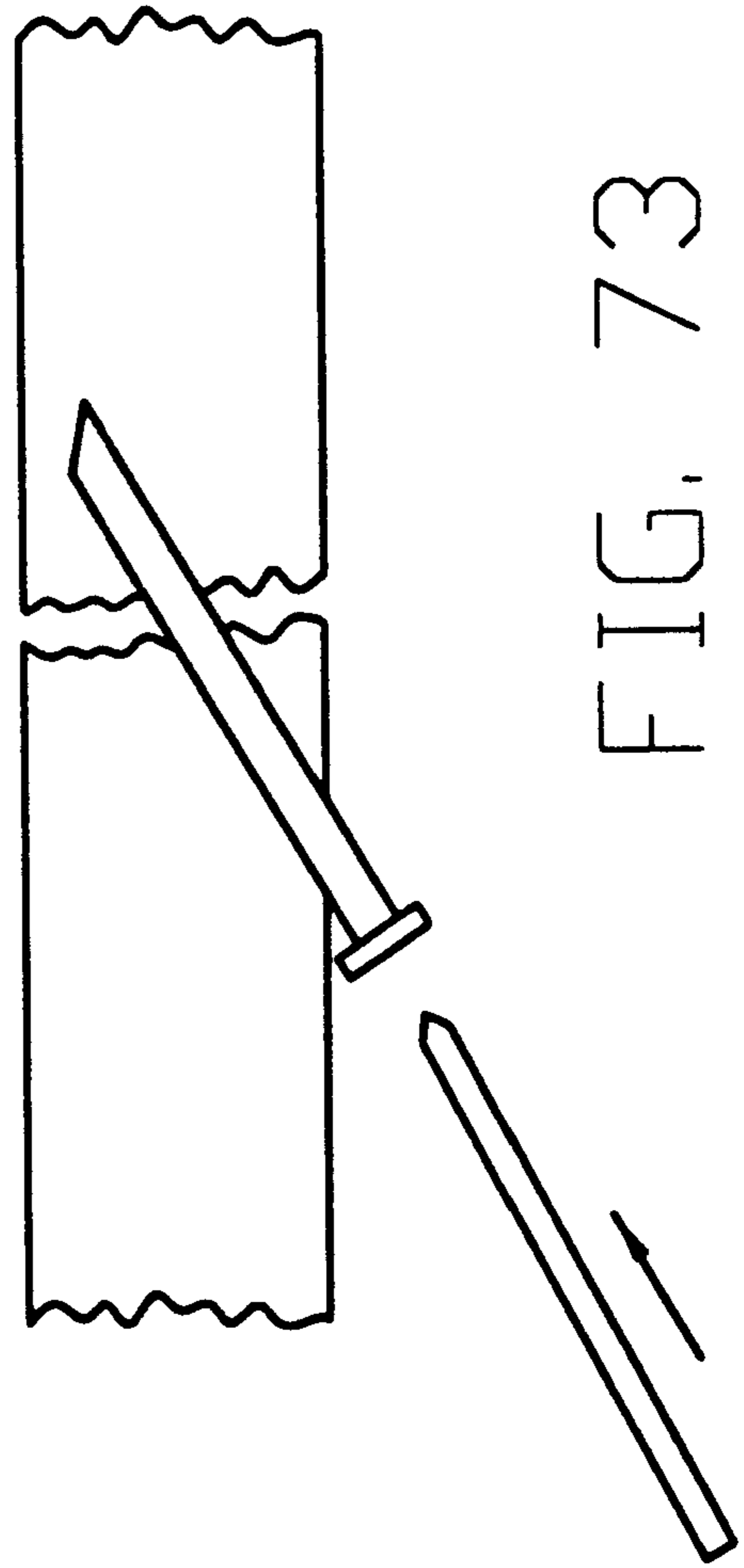

FIG. 73

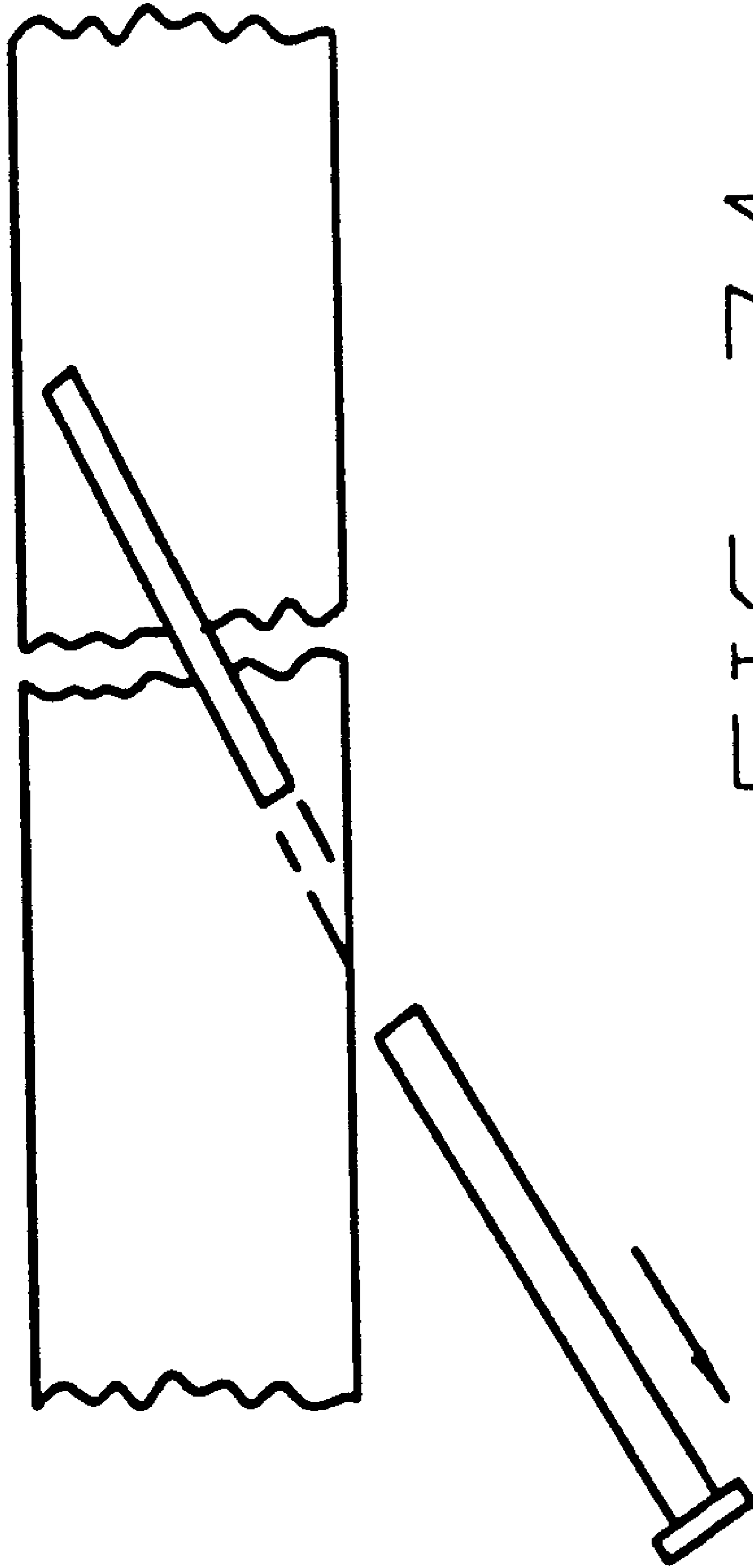

FIG. 74

METHOD AND APPARATUS FOR FIXING A GRAFT IN A BONE TUNNEL

CROSS-REFERENCE TO RELATED APPLICATION

This is a continuation-in-part of application Ser. No. 08/783,627, filed Jan. 14, 1997, and issued Dec. 15, 1998 as U.S. Pat. No. 5,849,013.

FIELD OF THE INVENTION

This invention relates to surgical methods and apparatus in general, and more particularly to methods and apparatus for fixing bone blocks in bone tunnels.

BACKGROUND OF THE INVENTION

The complete or partial detachment of ligaments, tendons and/or other soft tissues from their associated bones within the body are relatively commonplace injuries. Tissue detachment may occur as the result of an accident such as a fall, overexertion during a work-related activity, during the course of an athletic event, or in any one of many other situations and/or activities. Such injuries are generally the result of excess stress being placed on the tissues.

In the case of a partial detachment, commonly referred to under the general term "sprain", the injury frequently heals itself, if given sufficient time, and if care is taken not to expose the injury to undue stress during the healing process. If, however, the ligament or tendon is completely detached from its associated bone or bones, or if it is severed as the result of a traumatic injury, partial or permanent disability may result. Fortunately, a number of surgical procedures exist for re-attaching such detached tissues and/or completely replacing severely damaged tissues.

One such procedure involves the re-attachment of the detached tissue using "traditional" attachment devices such as staples, sutures and/or cancellous bone screws. Such traditional attachment devices have also been used to attach tendon or ligament grafts (often formed from autogenous tissue harvested from elsewhere in the body) to the desired bone or bones.

Another procedure is described in U.S. Pat. No. 4,950,270, issued Aug. 21, 1990 to Jerald A. Bowman et al. In this procedure, the damaged anterior cruciate ligament ("ACL") in a human knee, for example, is replaced by first forming bone tunnels through the tibia and femur at the points of normal attachment of the anterior cruciate ligament. Next, a ligament graft with a bone block on one of its ends is sized so as to fit within the bone tunnels. Suture is then attached to the bone block and thereafter passed through the tibial and femoral bone tunnels. The bone block is then drawn through the tibial tunnel and up into the femoral tunnel using the suture. As this is done, the graft ligament extends back out of the femoral tunnel, across the interior of the knee joint, and then through the tibial tunnel. The free end of the graft ligament resides outside the tibia, at the anterior side of the tibia. Next, a bone screw is inserted between the bone block and the wall of femoral bone tunnel so as to securely lock the bone block in position by a tight interference fit. Finally, the free end of the graft ligament is securely attached to the tibia.

In U.S. Pat. No. 5,147,362, issued Sep. 15, 1992 to E. Marlowe Goble, there is disclosed a procedure wherein aligned femoral and tibial tunnels are formed in a human knee. A bone block with a graft ligament attached thereto is passed through the tunnels to a blind end of the femoral tunnel where the block is fixed in place by an anchor. The

ligament extends out the tibial tunnel, and the end thereof is attached to the tibial cortex by staples or the like. Alternatively, the end of the ligament may be fixed in the tibial tunnel by an anchor or by an interference screw.

Various types of ligament and/or suture anchors, and anchors for attaching other objects to bone, are also well known in the art. A number of these devices are described in detail in U.S. Pat. Nos. 4,898,156; 4,899,743; 4,968,315; 5,356,413; and 5,372,599, each of which is presently owned by Mitek Surgical Products, Inc. of Westwood, Mass., the assignee of this patent application.

One known method for anchoring bone blocks in bone tunnels is through "cross-pinning", in which a pin, screw or rod is driven into the bone transversely to the bone tunnel so as to intersect the bone block and thereby cross-pin the bone block in the bone tunnel. In order to provide for proper cross-pinning of the bone block in the bone tunnel, a drill guide is generally used. The drill guide serves to ensure that the transverse passage is positioned in the bone so that it will intersect the appropriate tunnel section and the bone block. Drill guides for use in effecting such transverse drilling are shown in U.S. Pat. Nos. 4,901,711; 4,985,032; 5,152,764; 5,350,380; and 5,431,651.

Other patents in which cross-pinning is discussed include U.S. Pat. Nos. 3,973,277; 5,004,474; 5,067,962; 5,266,075; 5,356,435; 5,376,119; 5,393,302; and 5,397,356.

In U.S. Pat. No. 5,431,651, issued Jul. 11, 1995 to E. Marlowe Goble, it is said that a cross-pin screw may be formed out of a material which may be absorbed by the body over time, thereby eliminating any need for the cross-pin screw to be removed in a subsequent surgical procedure.

However, such absorbable cross-pin screws as are presently known in the art lack sufficient strength to be passed directly into the bone and the bone block. Accordingly, to use absorbable cross-pin screws, one must first drill a hard metal drilling implement into the bone and bone block, remove the drilling implement, and then replace the drilling implement with the absorbable cross-pin screw. However, removal of the hard metal drilling implement often permits the bone block to shift in the tunnel, such that the subsequent insertion of the absorbable cross-pin screw becomes impossible.

Accordingly, there exists a need for a method and apparatus for fixing a bone block in a bone tunnel such that upon completion of the procedure, the bone block is cross-pinned in the bone tunnel by elements which are made of absorbable material.

OBJECTS OF THE INVENTION

The object of the present invention is, therefore, to provide a method for fixing a bone block in a bone tunnel such that the bone block is retained in the tunnel by cross-pins which are made of a material which is absorbable by the body.

A further object of the present invention is to provide devices by which the aforementioned method may be realized.

SUMMARY OF THE INVENTION

These and other objects of the present invention are addressed by the provision and use of a novel method and apparatus for fixing a bone block in a bone tunnel.

In one form of the invention, the novel method comprises the steps of placing the bone block in the bone tunnel, and then advancing spaced-apart first and second drill means

through the bone transversely of the bone tunnel so as to intersect the bone block and extend therethrough. The method further includes the steps of removing one of the drill means and replacing the one removed drill means with a first absorbable rod, and then removing the other of the drill means and replacing the other removed drill means with a second absorbable rod, whereby the bone block will be retained in the bone tunnel with the absorbable rods. In one form of the invention, the first and second drill means may comprise metal wires.

The objects of the present invention are further addressed by the provision and use of an alternative method for fixing a bone block in a bone tunnel. The method comprises the steps of placing the bone block in the bone tunnel, and then advancing spaced-apart first and second trocar and sleeve assemblies through the bone, transversely of the bone tunnel, so as to intersect the bone block and extend therethrough, the trocar in each of the assemblies being disposed within one of the sleeves of the assemblies and substantially filling the sleeve. The method further includes the steps of removing the trocar from the first of the sleeves, advancing a first absorbable rod through the first sleeve and through the bone block, and then removing the first sleeve, so as to leave the first absorbable rod in the bone and the bone block. The method further includes the steps of removing the trocar from the second of the sleeves, advancing a second absorbable rod through the second sleeve and through the bone block, and then removing the second sleeve, so as to leave the second absorbable rod in the bone and the bone block, whereby the bone block will be retained in the bone tunnel with the absorbable rods.

The objects of the present invention are further addressed by the provision and use of another alternative method for fixing a bone block in a bone tunnel. The method comprises the steps of placing the bone block in the bone tunnel, and then advancing spaced-apart first and second trocar and sleeve assemblies through the bone transversely of the bone tunnel so as to intersect the bone block and extend therethrough, the trocar in each of the assemblies being disposed within one of the sleeves of the assemblies and substantially filling the sleeve. The method further includes the steps of removing the trocar from the sleeves, advancing absorbable rods through the sleeves and through the bone block, and then removing the sleeves from the bone block and the bone, so as to leave the absorbable rods in the bone block and the bone, whereby the bone block will be retained in the bone tunnel with the absorbable rods.

In accordance with a further feature of the present invention, there is provided a rack assembly for cross-pinning a bone block in a bone tunnel in a human femur, the rack assembly comprising an L-shaped member having a base portion and an arm portion extending transversely of the base portion, and a cannulated sleeve for movement through a tibia and into the femur and for disposition in the femoral bone tunnel, the cannulated sleeve having an enlarged head portion at a free end thereof for disposition in the bone tunnel in the femur and being connectable to the base portion of the L-shaped member at an opposite end thereof. The rack assembly further includes a trocar sleeve guide member removably connectable to the arm portion of the L-shaped member and having bores extending there-through at an angle normal to a longitudinal axis of the cannulated sleeve's head portion, first and second trocar sleeves for movable disposition in the bores, respectively, and at least one trocar for disposition in the trocar sleeves, the trocar being interconnectable with the trocar sleeve in which the trocar is disposed such that the trocar sleeve and

the trocar therein are movable axially toward the cannulated sleeve's head portion and rotatable together, such that the interconnected trocar and trocar sleeve are adapted for drilling into the femur and the bone block. The trocar is removable from the trocar sleeves, and absorbable rods are provided for sliding through the trocar sleeves and through the bone block, the trocar sleeves being removable from the bone block and the femur and from the absorbable rods, so as to leave the absorbable rods in the bone block and the femur.

In accordance with a still further feature of the present invention, there is provided another rack assembly for cross-pinning a bone block in a bone tunnel in a human femur. The rack assembly comprises an L-shaped member having a base portion and an arm portion extending transversely of the base portion, and a cannulated sleeve for movement through the femur until a free end thereof is disposed adjacent to the bone block, with an opposite end thereof being connectable to the base portion of the L-shaped member. A trocar sleeve guide member is removably connectable to the arm portion of the L-shaped member and is provided with bores extending therethrough at an angle normal to a hypothetical extension of a longitudinal axis of the cannulated sleeve. First and second trocar sleeves are provided for movable disposition in the bores, respectively. At least one trocar is provided for disposition in the trocar sleeves, the trocar being interconnectable with the trocar sleeve in which the trocar is disposed such that the trocar sleeve and the trocar therein are movable axially toward the bone block and rotatable together, such that the interconnected trocar and trocar sleeve are adapted for drilling into the femur and the bone block. The trocar is removable from the trocar sleeves, and absorbable rods are slidable through the trocar sleeves and through the bone block, the trocar sleeves being removable from the bone block and the femur and from the absorbable rods so as to leave the absorbable rods in the bone block and the femur.

In accordance with a further feature of the invention, there is provided a method for fixing a bone block in a bone tunnel in a bone, the method comprising the steps of:

forming a bone tunnel in the bone, the bone tunnel comprising an open end, a portion adjacent the open end having a transverse diameter sized to receive the bone block and an at least partially closed end located internally of the bone;

locating the bone block in the bone tunnel such that one end thereof is disposed substantially adjacent to the at least partially closed end of the bone tunnel;

advancing a drill means through the bone transversely of the bone tunnel such that the drill means intersects and extends through the bone tunnel and back into the bone substantially adjacent the other end of the bone block; and

removing the drill means from the bone and replacing the drill means with a rod;

whereby to retain the bone block in the bone tunnel between the at least partially closed end and the rod.

In accordance with a further feature of the invention, there is provided a method for deploying an element in bone, the method comprising the steps of:

providing a trocar and trocar sleeve combination comprising a hollow sleeve having a distal end, a proximal end and a longitudinal length, wherein the interior of the sleeve defines a substantially cylindrical longitudinal passageway between the proximal end and the distal end, and a pair of opposing grooves in the

5

sidewall of the passageway, the grooves extending respectively from the proximal end of the sleeve to opposing closed ends spaced from the distal end of the sleeve; and

a trocar including a shaft having a transverse cross-section adapted to be slidably received in the passageway, a pointed distal end adapted for drilling into bone and a pair of opposing projections adapted to be slidably received in the grooves when the shaft is located in the passageway such that the extension of the pointed end out of the distal end is limited according to the longitudinal distance between the pointed end and the projections in relation to the longitudinal spacing of the closed groove ends from the distal end of the shaft;

whereby when the trocar is inserted into the passageway, the resulting trocar and trocar sleeve combination may be rotated and drilled distally into bone as a unit and the trocar may be slidably, proximally removed from the sleeve;

drilling the trocar and trocar sleeve combination into the bone;

removing the trocar from the trocar sleeve;

inserting the element into the bone through the passageway of the sleeve; and

removing the sleeve from the element and the bone.

In accordance with a further feature of the invention, there is provided a method for fixing a portion of a piece of tissue in a bone tunnel, the method comprising:

advancing a trocar and trocar sleeve combination into a bone transversely to a bone tunnel formed therein such that the trocar and trocar sleeve combination extends through the bone and across the bone tunnel;

removing the trocar from the trocar sleeve;

inserting an absorbable rod into the bone through the sleeve and removing the sleeve so as to leave the absorbable rod extending across the bone tunnel;

attaching one end of a length of cord-like material to the piece of tissue adjacent the portion thereof which is to be located in the bone tunnel;

threading the other end of the length of cord-like material into an open end of the bone tunnel, around the absorbable pin extending across the bone tunnel, and back out of the open end of the bone tunnel; and

pulling on the other end of the cord-like material so as to draw the portion of the piece of tissue into the open end of the bone tunnel, around the absorbable pin extending across the bone tunnel, and back out of the open end of the bone tunnel,

whereby the portion of the piece of tissue is looped over the absorbable pin within the bone tunnel for fixation therein by securement of the portions of the piece of tissue extending out of the open end of the bone tunnel.

In accordance with a further feature of the invention, there is provided a method for fixing a bone block in a bone tunnel in a bone, the method comprising the steps of:

placing a solid bone block in the bone tunnel;

advancing at least one trocar and trocar sleeve assembly into the bone transversely of the bone tunnel such that the distal end of the at least one trocar and trocar sleeve assembly resides in the bone proximate the sidewall of the bone tunnel, the trocar in the at least one assembly being disposed within and substantially filling its associated trocar sleeve;

removing the trocar from the at least one trocar and trocar sleeve assembly and inserting a rod into the at least one sleeve;

6

slidably inserting one end of an elongate shaft into the sleeve so as to abut the rod;

tapping the other end of the elongate shaft so as to drive the rod out of the sleeve, through the bone and into the bone block.

In accordance with a further feature of the invention, there is provided a method of maintaining reduced fractures in bone in position for healing, the method comprising the steps of:

advancing at least one trocar and trocar sleeve assembly through the bone on one side of a reduced fracture, across the reduced fracture and into the bone on the other side of the reduced fracture, the trocar in each of the at least one trocar and trocar sleeve assembly substantially filling its associated sleeve;

removing the trocar from the at least one trocar and trocar sleeve assemblies;

inserting a rod through the at least one sleeve and into the bone on the other side of the reduced fracture; and

removing the at least one sleeve from the bone and the rod so as to leave the rod in the bone extending across the reduced fracture.

In accordance with a further feature of the invention, there is provided a method for delivering materials into the interior of bones, the method comprising the steps of:

advancing at least one trocar and trocar sleeve assembly into the interior of a bone, the trocar in the at least one trocar and trocar sleeve assembly substantially filling its associated sleeve;

removing the trocar from the at least one trocar and trocar sleeve assembly;

delivering the materials to the interior of the bone through the at least one sleeve; and

removing the at least one sleeve from the bone.

In accordance with a further feature of the invention, there is provided a method for fixing a bone block in a bone tunnel, the method comprising the steps of:

providing a rack assembly including an L-shaped member having a base portion and an arm portion extending transversely of the base portion, a cannulated sleeve at one end thereof releasably connectable to the base portion of the L-shaped member and, at the other end thereof, adapted for disposition in the bone tunnel to align the rack assembly relative to the intended fixation location of the bone block, a trocar sleeve guide member removably connectable to the arm portion of the L-shaped member such that bores extending there-through are disposed at an angle transverse to the intended fixation location of the bone block in the bone tunnel, first and second trocar sleeves for movable disposition in the bores, respectively, at least one trocar for movable disposition in the trocar sleeves, the at least one trocar being interconnectable with the trocar sleeve in which it is disposed, each the trocar sleeve, when the at least one trocar is located therein, being movable axially toward the intended fixation location of the bone block and rotatable together with the trocar such that the interconnected trocar and trocar sleeve are adapted for drilling into the bone, the at least one trocar being respectively removable from the trocar sleeves, and rods for sliding into the trocar sleeves;

with the cannulated sleeve in its aligning position in the bone tunnel and the sleeve guide member connected to the arm, advancing the trocar and trocar sleeve assemblies into the bone but not into the bone tunnel;

removing the at least one trocar from the trocar and trocar sleeve assemblies;
 removing the cannulated sleeve from the bone tunnel and the first and second sleeves from the sleeve guide;
 locating a bone block in the bone tunnel in alignment with axial projections of the first and second sleeves disposed in the bone;
 providing a first elongate trocar and advancing the first trocar through the first sleeves, through the bone located between the distal ends of the first sleeves and the bone tunnel, and into the bone block;
 providing a second elongate trocar and advancing the second trocar through the second sleeve, through the bone between the distal end of the second sleeve and the bone tunnel, and into the bone block;
 removing the second elongate trocar from the bone block, the bone and the second sleeve;
 inserting a rigid rod through the second sleeve and into the bone and the bone block;
 removing the first elongate trocar from the bone block, the bone and the first sleeve;
 inserting another rigid rod through the first sleeve into the bone and the bone block; and
 removing the first and second sleeves from the bone.

In accordance with a further feature of the invention, there is provided a trocar and trocar sleeve assembly for use in forming passageways in bone, the assembly comprising:

a trocar comprising a shaft, a distal drilling tip and at least one projection extending radially of the shaft at a pre-selected longitudinal distance proximally of the distal tip; and

a trocar sleeve having a distal end and a proximal end defining a longitudinal bore extending between the distal end and the proximal end, and at least one longitudinal groove in the sidewall of the bore extending from the proximal end of the sleeve to a closed distal end located a pre-selected longitudinal distance proximally of the distal end of the sleeve;

the trocar being adapted to slidably engage the bore of the sleeve with the at least one radial projection slidably engaging the at least one longitudinal groove, and the pre-selected longitudinal distance being such that when the at least one radial projection engages the closed end of the at least one longitudinal groove, the distal drilling tip of the trocar projects distally of the distal end of the sleeve,

whereby the trocar and the trocar sleeve may be releasably interconnected with one another for integral rotational and distally directed longitudinal movement.

In accordance with a further feature of the invention, there is provided a surgical kit for locating objects or materials in bone, the kit comprising:

at least two trocar sleeves, at least one trocar adapted for releasable interconnection with the sleeves for integral rotational and distal longitudinal movement therewith, at least one elongated, stepped trocar adapted for slidable and rotational movement through the sleeves and into bone, a rack assembly adapted for controlling the angle at which the sleeves and trocars penetrate the bone so as to provide passageways into which the objects and/or materials may be inserted, and plunger and tapping means adapted to pass the objects and/or materials into the bone via passageways formed therein by the sleeves and trocars.

BRIEF DESCRIPTION OF THE DRAWINGS

The above and other objects and features of the present invention will be more fully discussed in, or rendered

obvious by, the following detailed description of the preferred embodiments of the invention, which is to be considered together with the accompanying drawings wherein like members refer to like parts, and further wherein:

FIG. 1 is a diagrammatical sectional view of a human knee joint, with appropriate bone tunnels formed therein and with a ligament bone block disposed in one of the tunnels;

FIG. 2 is similar to FIG. 1, but illustrative of a metal wire insertion phase of the inventive method;

FIG. 3 is similar to FIG. 2 but illustrative of completion of the metal wire insertion phase;

FIG. 4 is similar to FIG. 3, but illustrative of a first metal wire withdrawal phase;

FIG. 5 is similar to FIG. 4, but illustrative of a first absorbable rod insertion phase;

FIG. 6 is similar to FIG. 5, but illustrative of the first absorbable rod having been fully inserted;

FIG. 7 is similar to FIG. 6, but illustrative of a second metal wire withdrawal phase;

FIG. 8 is similar to FIG. 7, but illustrative of a second absorbable rod insertion phase;

FIG. 9 is similar to FIG. 8, but illustrative of the completion of the absorbable rod insertion phase of the inventive method;

FIG. 10 is a side elevational view of one form of rack assembly for cross-pinning a bone block in a bone tunnel, illustrative of an embodiment of the invention;

FIG. 11 is a bottom view of the rack assembly of FIG. 10;

FIG. 12 is a bottom view of a trocar sleeve guide member portion of the rack assembly of FIGS. 10 and 11;

FIG. 13 is a side elevational view of the trocar sleeve guide member;

FIG. 14 is a front elevational view of the trocar sleeve guide member;

FIG. 15 is an interrupted side elevational view of a trocar portion of the rack assembly of FIG. 10;

FIG. 16 is an interrupted side elevational view, broken away and partly in section, of a trocar sleeve portion of the rack assembly of FIG. 10;

FIG. 17 is an end view of the trocar sleeve portion of FIG. 16;

FIG. 18 is a diagrammatical view of a human knee joint and illustrative of a step in a method in which the rack assembly of FIG. 10 is used;

FIGS. 19-28 are diagrammatical views illustrating a series of steps in the use of the rack assembly of FIG. 10;

FIG. 29 is a side elevational view of another form of rack assembly illustrative of an alternative embodiment of the invention;

FIG. 30 is a bottom view of the rack assembly of FIG. 29;

FIG. 31 is a bottom view of a trocar sleeve guide member portion of the rack assembly of FIG. 29;

FIG. 32 is a side elevational view of the trocar sleeve guide member;

FIG. 33 is a front elevational view of the trocar sleeve guide member;

FIG. 34 is a view similar to that of FIG. 18;

FIGS. 35-40 are diagrammatical views illustrating a series of steps in the use of the rack assembly of FIG. 29;

FIG. 41 is a side elevational view of a graft ligament, tendon or the like, wherein one end of the graft has been folded back upon itself and tack-stitched in place, and wherein a rod extending through the tissue is shown in phantom;

FIG. 42 is a side elevational view similar to FIG. 41, wherein the graft ligament, tendon or the like has been folded back upon itself, and wherein a rod extending between adjacent folds of the graft is shown in phantom;

FIG. 43 is a side elevational view similar to FIG. 42, wherein the folded tissue has been "whip stitched" together, and wherein a rod extending through the whip stitched tissue mass is shown in phantom;

FIGS. 44-51 are illustrative sectional side elevational views showing the steps of advancing a trocar/trocar sleeve combination into a bone and through a bone tunnel therein, removing the trocar, inserting a rod into the sleeve and across the bone tunnel, removing the sleeve, and pulling an end of a tissue graft around the rod located across the bone tunnel;

FIGS. 52 and 53 are illustrative side elevational views of representative bone blocks showing two possible examples of how a bone block may fracture during or after the placement of a cross-pin therethrough;

FIG. 54 is an illustrative sectional side elevational view of a bone block located in a partially closed ended bone tunnel and fixed in position by a rod extending across the bone tunnel between the bone block and the open end of the bone tunnel;

FIG. 55 is an illustrative side elevational view of an assembled trocar/trocar sleeve assembly for use in the present invention;

FIGS. 56-63 are illustrative side sectional, elevational views showing the use of long trocars inserted through sleeves, originally placed with the combination depicted in FIG. 55, to penetrate the bone and a bone block for the emplacement of rods to hold the bone block in place within the bone tunnel;

FIG. 64 is a side elevational view of a stepped trocar formed in accordance with the present invention;

FIG. 65 is a side elevational, sectional view showing a trocar sleeve having an internal stop adapted to limit the travel of a stepped trocar, as depicted in FIG. 64, therethrough;

FIG. 66 is an exploded, side sectional, elevational view illustrating the use of a plunger and tapping device for driving a rod through a sleeve in bone and into a bone block located in a bone tunnel;

FIG. 67 is a side elevational view of another trocar/trocar sleeve combination formed in accordance with the present invention;

FIG. 68 is a side elevational view of still another trocar/trocar sleeve combination formed in accordance with the present invention;

FIG. 69 is an illustrative perspective view showing an apertured head substituted for the enlarged cannulated sleeve head depicted in FIG. 19; and

FIGS. 70-74 are illustrative side elevational views showing the disposition of a rod across a reduced bone fracture using a trocar/trocar sleeve combination formed in accordance with the present invention.

DETAILED DESCRIPTION OF THE PREFERRED EMBODIMENTS

Referring first to FIG. 1, it will be seen that a human knee joint 10, including a femur 12 and tibia 14, has been provided with an appropriate femoral bone tunnel 16 and an appropriate tibial bone tunnel 18. Such tunnels may be provided in ways well known in the art. A bone block 20,

having ligament material 22 attached thereto, has been positioned in femoral tunnel 16. Such bone block positioning may also be achieved in ways well known in the art.

Looking next at FIG. 2, in accordance with the present invention, a first metal wire 30, which may be of the type commonly referred to as a guidewire or a "K-wire", is advanced through skin 31 and a first portion 32 of femur 12. First wire 30 is advanced transversely of femoral tunnel 16 so as to intersect and extend through bone block 20, as shown in FIG. 2. Thereafter, or simultaneously therewith, a second metal wire 34 is advanced through a second portion 36 of femur 12. Second wire 34 is also advanced transversely of femoral tunnel 16 so as to also intersect and extend through bone block 20 (FIG. 3). At this point, bone block 20 is securely held in femoral tunnel 16 by the two spaced-apart metal wires 30, 34.

Referring next to FIG. 4, it will be seen that one of the two wires 30, 34 is then removed, while the other of the two wires 30, 34 is left in place in femur 12 and bone block 20. By way of example but not limitation, wire 30 may be removed while wire 34 is left in place. A first absorbable rod 40 (FIG. 5) is then advanced through the bore 42 left by the removal of first wire 30, such that first absorbable rod 40 extends through femur 12 and bone block 20 (FIG. 6). At this point, bone block 20 is securely held in femoral tunnel 16 by both metal wire 34 and first absorbable rod 40.

Thereafter, the other of the two metal wires 30, 34 is withdrawn (e.g., in FIG. 7, metal wire 34 is removed), and a second absorbable rod 44 (FIG. 8) is advanced through the bore 46 left by the removal of metal wire 34, such that second absorbable rod 44 also extends through femur 12 and bone block 20 (FIG. 9).

It will be appreciated that, upon completion of the insertion of second absorbable rod 44 (FIG. 9), bone block 20 is retained in femoral tunnel 16 solely by the absorbable rods 40, 44.

The absorbable rods 40, 44 may be made out of a material such as polylactic acid (PLA), polyglycolic acid (PGA), polydioxanone (PDS), or out of some other such material which is formable into a relatively rigid and hard configuration, but which is absorbable by the body of the patient over time. If desired, the distal ends of absorbable rods 40, 44 can be pointed or rounded so as to facilitate their deployment into the body.

There is thus provided a method by which a bone block is fixed within a bone tunnel, such that the bone block is anchored in the tunnel by cross-pins which are made out of a material which is absorbable by the body over time.

It will be understood that while the above method has been described and illustrated with respect to first and second wires replaced serially by first and second absorbable rods, the method may be exercised with any reasonable number of wires, exceeding one. In the latter instance, the method includes the steps of placing the bone block in the bone tunnel, and then advancing a plurality of metal wires through the bone, transversely of the tunnel, so as to intercept the bone block and extend therethrough. At least one of the wires is then removed while leaving at least one of the wires in place, and that at least one removed wire is then replaced by at least one absorbable rod. At least one further of the wires is then removed and that at least one removed wire is then replaced by at least one further absorbable rod. The last-mentioned step is then repeated until a selected number of the metal wires is each replaced with an absorbable rod, whereby to retain the bone block in the bone tunnel with absorbable rods.

It will also be understood that while FIGS. 1-9 show metal wires 30, 34 and absorbable rods 40, 44 passing completely through bone block 20 during the cross-pinning procedure, it is also possible for metal wires 30, 34 and absorbable rods 40, 44 to pass only part way across bone block 20, if the same should be desired.

Furthermore, it will also be understood that while the above method has been described and illustrated with respect to metal wires 30, 34 being used to drill through femur 12 and bone block 20, other drilling implements (e.g., a twist drill or a spade drill) might also be used.

As noted above, various drill guides have been developed for forming transverse passages through the femur and bone block so as to cross-pin the bone block within the femoral tunnel. If desired, the inventive method of the present invention may be practiced using such known drill guides. Alternatively, the present invention may also be practiced using a novel rack assembly formed in accordance with the present invention.

More particularly, and looking now at FIGS. 10-17, a novel rack assembly 50 is disclosed for practicing the present invention. Rack assembly 50 comprises an L-shaped member 52 having a base portion 54 and an arm portion 56. The arm portion 56 extends transversely, and preferably is normal to, base portion 54.

Rack assembly 50 also includes a cannulated sleeve 58 which, at a first end 60 thereof, is provided with an enlarged head portion 62, and which, at a second end 64 thereof, is releasably connectable to base portion 54 of L-shaped member 52. Sleeve 58 may be retained in a bore 65 (FIG. 11) formed in base portion 54 by a set screw 66.

A trocar sleeve guide member 70 is removably connectable to arm portion 56 of L-shaped member 52. Trocar sleeve guide member 70 is provided with bores 72 extending therethrough. Bores 72 extend substantially normal to a longitudinal axis 68 (FIG. 10) of the enlarged head portion 62 of cannulated sleeve 58. A set screw 71 (FIG. 11) may be used to releasably retain trocar sleeve guide member 70 in position on arm portion 56. Alternatively, or in addition, arm portion 56 may be provided with stop means (not shown) for limiting the movement of the trocar sleeve guide member 70 along arm portion 56. Trocar sleeve guide member 70 is preferably formed in two halves releasably held together by a set screw 73 (FIG. 11), whereby trocar sleeve guide member 70 can be slidably mounted on, or detached from, trocar sleeves 74, 76 passing through bores 72, as will hereinafter be discussed.

First and second trocar sleeves 74, 76 are slidably received by bores 72, such that sleeves 74, 76 are axially and rotatably movable in bores 72. Referring to FIGS. 16 and 17, it will be seen that trocar sleeve 74 is provided with a collar portion 78 having a slot 80 formed therein. Sleeve 76 is substantially identical to sleeve 74.

Rack assembly 50 also includes one or more trocars 82 (FIGS. 10 and 15) for disposition in the sleeves 74, 76. Each trocar 82 is provided with a sharp end 84 (FIG. 15) for penetration of bone. A transversely-extending pin 86 is provided near (but spaced from) the opposite end of the trocar 82. Pin 86 is fixed in place and is receivable by the slots 80 of trocar sleeves 74, 76 such that axial (in a distal direction) and rotational movement of trocar 82 causes similar movement of sleeves 74, 76.

The first and second absorbable rods 40, 44 are slidable through sleeves 74, 76, as will be further described hereinbelow.

FIGS. 18-28 illustrate how rack assembly 50 may be used to practice the present invention.

Referring now to FIG. 18, there is shown a human knee joint 10 including femur 12 and tibia 14. An appropriate femoral tunnel 16 and an appropriate tibial tunnel 18 have been provided, as by means and methods well known in the art. A guidewire 90 extends through the bone tunnels 16, 18 as shown.

In accordance with the present invention, the rack assembly's cannulated sleeve 58 is fed over guidewire 90, through tibial tunnel 18 and into femoral tunnel 16, until the cannulated sleeve's head portion 62 engages an annular shoulder 92 in femoral tunnel 16 (FIG. 19). As this occurs, guidewire 90 extends through a bore 94 (FIGS. 10 and 19) formed in base portion 54 of L-shaped member 52. The cannulated sleeve's head portion 62 is preferably sized so as to form a snug fit in femoral tunnel 16. Cannulated sleeve 58 may be positioned in the bone tunnels 16, 18 and then connected to L-shaped member 52 or, more preferably, cannulated sleeve 58 may be first connected to L-shaped member 52 and then positioned in femur 12 and tibia 14. Trocar sleeve guide member 70, if not already positioned on arm portion 56, is then fixed to arm portion 56, as by set screw 71 (FIG. 11).

First trocar sleeve 74 is then inserted in a bore 72 of guide member 70 (FIG. 20), and trocar 82 is extended through sleeve 74 until pin 86 (FIG. 15) of trocar 82 is nested in slot 80 (FIGS. 16 and 17) of sleeve 74, with the trocar's sharp end 84 extending beyond the distal end of sleeve 74 (FIG. 20). Alternatively, trocar 82 may be mounted in first trocar sleeve 74 before first trocar sleeve 74 is mounted in a bore 72. The combination of trocar sleeve 74 and trocar 82 is then drilled, as a unit, into femur 12 toward, but short of, the enlarged head portion 62 of cannulated sleeve 58 (FIG. 20).

Trocar 82 may then be withdrawn from first trocar sleeve 74 and placed in second trocar sleeve 76 (FIG. 21). Alternatively, a second trocar 82 may be provided for second trocar sleeve 76. In either case, the combination of trocar sleeve 76 and trocar 82 is then drilled, as a unit, into femur 12 toward, but short of, head portion 62 of cannulated sleeve 58. The rack's L-shaped member 52 may then be removed from the surgical site. This may be accomplished by first loosening set screw 73 (FIG. 11) so as to separate trocar sleeve guide member 70 into its two halves, whereby trocar sleeves 74, 76 will be freed from guide member 70, and then sliding cannulated sleeve 58 downward along guidewire 90 until the cannulated sleeve emerges from bone tunnels 16, 18. This procedure will leave trocar sleeves 74, 76 lodged in femur 12 (FIG. 22).

Guidewire 90 is then used to pull a suture 96, which is attached to bone block 20, up through tibial tunnel 18 and into femoral tunnel 16, until bone block 20 engages the annular shoulder 92 in femoral tunnel 16 (FIG. 23). Guidewire 90 may be provided with an eyelet (not shown) adjacent to its proximal end so as to facilitate this procedure. Bone block 20 can then be held in this position by maintaining tension on the portion of suture 96 emerging from the top of femur 12.

Trocar sleeve 76 and trocar 82 are then drilled through bone block 20, as shown in FIG. 24. Trocar 82 may then be removed from sleeve 76, placed in sleeve 74, and sleeve 74 and trocar 82 drilled through bone block 20, as shown in FIG. 25. The trocar 82 (or trocars 82 if more than one trocar is used) may then be withdrawn from the sleeve 74 (or sleeves 74, 76). The first absorbable rod 40 is then inserted, by sliding rod 40 through trocar sleeve 74 into a position extending through bone block 20 (FIG. 26). Sleeve 74 may then be withdrawn from bone block 20 and femur 12,

leaving first absorbable rod **40** in place in femur **12** and extending through bone block **20**, as shown in FIG. **27**.

Similarly, second absorbable rod **44** is then slid into place through sleeve **76**. Sleeve **76** is then removed, leaving second absorbable rod **44**, along with first absorbable rod **40**, extending through bone block **20** so as to lock bone block **20** in place in femoral tunnel **16**, as shown in FIG. **28**.

It should be appreciated that it is also possible to provide rack assembly **50** with a guide member **70** which is not formed in two separable halves. In this situation, when the rack's L-shaped member **52** is to be withdrawn from the surgical site (see FIGS. **21** and **22**), guide member **70** can simply be detached from L-shaped member **52** by unscrewing set screw **71**. Guide member **70** can then be left mounted on the outboard portions of sleeves **74**, **76** until sleeves **74**, **76** are withdrawn from the surgical site, with guide member **70** being removed with the last of the sleeves **74**, **76**.

The present invention may also be practiced using the novel rack assembly **100** illustrated in FIGS. **29–33**. Rack assembly **100** comprises an L-shaped member **102** having a base portion **104** and an arm portion **106**. Arm portion **106** extends transversely of, and preferably is normal to, base portion **104**.

Rack assembly **100** also includes a cannulated sleeve **108** which, at a base end **110** thereof, is connected to base portion **104**. Cannulated sleeve **108** may be retained in a bore **112** in base portion **104**, as by screw threads or a set screw (not shown) or a press fit or the like. Cannulated sleeve **108** is provided with a slot **114** (FIG. **29**) extending substantially throughout the length of sleeve **108**. Base portion **104** of L-shaped member **102** is also provided with a slot **116** (FIG. **30**) which is alignable with the sleeve's slot **114** so as to place the slots **114**, **116** in communication with each other.

A trocar sleeve guide member **120** is removably connectable to arm portion **106** of L-shaped member **102**. Trocar sleeve guide member **120** is provided with bores **122** extending therethrough. Bores **122** extend substantially normal to a hypothetical extension of the longitudinal axis **124** of cannulated sleeve **108**. A set screw **126** (FIG. **30**) may be used to releasably retain trocar sleeve guide member **120** in position on arm portion **106**. To assist in positioning trocar sleeve guide member **120** on arm portion **106** of L-shaped member **102**, arm portion **106** may be provided with a stop means (not shown) for limiting movement of member **120** on arm portion **106**. Trocar sleeve guide member **120** is preferably formed in two halves releasably held together by a set screw **127** (FIG. **30**), whereby trocar sleeve guide member **120** can be slidably mounted on, or detachable from, trocar sleeves **128**, **130** passing through bores **122**, as will hereinafter be discussed.

First and second trocar sleeves **128**, **130** are received by bores **122**, such that sleeves **128**, **130** are axially and rotatably movable in bores **122**. The two trocar sleeves **128**, **130** are substantially identical to the sleeve **74** shown in FIGS. **16** and **17**. Rack assembly **100** also includes one or more trocars **132** for disposition in sleeves **128**, **130**. The trocar **132** is substantially identical to the trocar **82** shown in FIG. **15**. The aforementioned first and second absorbable rods **40**, **44** are slidable through sleeves **128**, **130**.

FIGS. **34–40** illustrate how rack assembly **100** may be used to practice the present invention.

Referring now to FIG. **34**, it will be seen that bone tunnels **16** and **18** are formed in femur **12** and tibia **18**, respectively, and a guidewire **90** extends through bone tunnels **16**, **18**. Guidewire **90** is then used to pull a suture **96**, which is attached to bone block **20**, up through tibial tunnel **18** and

into femoral tunnel **16**, such that bone block **20** is in engagement with annular shoulder **92** (FIG. **35**). Bone block **20** is kept in this position by maintaining tension on the portion of suture **96** emerging from the top of femur **12**.

Suture **96** is then introduced into the rack assembly's cannulated sleeve **108** and base portion **104** by way of slots **114**, **116**. Cannulated sleeve **108** is then passed down the hole **133** (FIGS. **35** and **36**) left by the removed guidewire **90** until the distal end of the cannulated sleeve engages the top end of bone block **20** (FIG. **36**). Next, first trocar sleeve **128** is extended through a guide member bore **122** and a trocar **132** is inserted into sleeve **128**. Alternatively, a trocar **132** may be inserted into first trocar sleeve **128** before first trocar sleeve **128** is inserted into a guide member bore **122**. The sleeve **128** and trocar **132** are then drilled, as a unit, into femur **12**. With bone block **20** held against shoulder **92** by pulling on suture **96**, the combination of sleeve **128** and trocar **132** is drilled through bone block **20** (FIG. **36**). In a similar manner, sleeve **130** and trocar **132** (either the same trocar used with sleeve **128** or another trocar) are then drilled through bone block **20**, as shown in FIG. **37**.

L-shaped member **102** and cannulated sleeve **108** are then removed from the surgical site. This may be accomplished by first loosening set screw **127** (FIG. **30**) so as to separate trocar sleeve guide member **120** into its two halves, whereby trocar sleeves **128**, **130** will be freed from guide member **120**, and then sliding cannulated sleeve **108** upward and out of hole **133**. Any trocars **132** are then removed, leaving the trocar sleeves **128**, **130** extending into femur **12** and across bone block **20**, as shown in FIG. **38**.

Second absorbable rod **44** is then slid through sleeve **130** and sleeve **130** removed (FIG. **39**), and first absorbable rod **40** is slid through sleeve **128** and sleeve **128** removed, leaving absorbable rods **40**, **44** in place (FIG. **40**) holding bone block **20** locked in femoral tunnel **16**.

Suture **96** is then slipped through bone block **20** and removed, in the manner well known in the art.

It is to be understood that the present invention is by no means limited to the application thereof as herein disclosed and/or as shown in the drawings. For example, for illustrative purposes, the inventive method and apparatus are described herein and illustrated with reference to the human knee joint. It is foreseen that the method and apparatus described herein will be particularly beneficial with respect to such operations. However, it will also be appreciated by those skilled in the art that the method and apparatus described herein find utility with respect to mammals generally, and with respect to other bones as, for example, in shoulder joints or the like.

By way of further example, trocars **82** and **132** and their associated sleeves **74**, **76** and **128**, **130**, respectively, might be passed only part way through bone block **20**, but not all the way through; or sleeves **74**, **76** and/or sleeves **128**, **130** might be stopped short of bone block **20** while trocars **82** and/or **132** penetrate into bone block **20**.

Furthermore, trocars **82** and **132** are disclosed herein as being in the form of a hard rod with a sharp tip for penetrating bone. Thus, for example, trocars **82** and **132** might comprise guidewires or K-wires with a pyramidal front point. Alternatively, however, the invention might also be practiced with trocars **82** and **132** comprising a twist drill, a spade drill and/or some other sort of drill.

Also it is contemplated that trocars **82** and/or **132** might be used with their associated rack assemblies **50** and **100**, respectively, but without their associated sleeves **74**, **76** and **128**, **130**, respectively. In this case, at least one trocar would

always remain positioned in bone block **20** until at least one absorbable rod **40, 44** was positioned in the bone block.

It desired, it is also possible to practice the present invention using just one sleeve **74** and one trocar **82**, or just one sleeve **76** and one trocar **82**; and it is possible to practice the invention using just one sleeve **128** and one trocar **132**, or just one sleeve **130** and one trocar **132**. In such a situation, the sleeve element would serve to retain the bone block in position within the bone tunnel while the trocar is replaced by the rod which will ultimately hold the bone block to the bone.

It should also be appreciated that the present application will have utility with respect to setting cross-pins which may not necessarily be absorbable. In particular, the present invention will have utility wherever cross-pinning needs to be achieved for cross-pins which cannot be passed directly through the bone and/or bone block, e.g., where the cross-pins may be too soft or too brittle or too fragile to pass directly through the bone and/or bone block, or where the cross-pins may have a geometry which makes it difficult or impossible for them to be passed directly through the bone and/or bone block. By way of example, the present invention might be used to set cross-pins made out of plastic and/or ceramic materials, or the present invention might be used to set cross-pins made out of metal.

In addition, numerous other alternatives are contemplated within the scope of the present invention in its broadest aspects.

More particularly, it will be understood by those skilled in the art that there are many instances wherein it is desired to locate a portion of a piece of soft tissue, such as a ligament, tendon or the like, within a bone tunnel, without a bone block attached to it. This may occur, for example, where a prosthetic substitute for a ligament, tendon or the like is to be used to effect a repair, or in those instances wherein it is undesirable for one reason or another to harvest a repair graft from elsewhere in the patient's body along with a bone block naturally attached to one end of the graft.

In such cases, a portion of the piece of tissue alone may be cross-pinned in a bone tunnel by any of the methods discussed above. Specifically, as shown in FIGS. **41** and **42**, the portion **150** of the piece of tissue **152** to be cross-pinned in the bone tunnel is preferably folded back upon itself one or more times. When this is done, tacking stitches **154** may be used to hold the layers **156** of folded tissue together while the resulting mass **150** is inserted or pulled into the bone tunnel in a manner similar to the procedures used to locate a bone block in a bone tunnel discussed above. Thereafter, cross-pinning proceeds substantially as discussed above, such that the rods **158** ultimately extend either through the tissue mass (see phantom lines in FIG. **41**), or between the folded tissue layers (see phantom lines in FIG. **42**), or both.

In this alternative, the chances of the rod and/or sleeve and/or trocar tearing laterally out of, or longitudinally along, the tissue **152** may be significant. This is particularly the case in those instances wherein the repair is to be subjected to substantial stress prior to complete healing. Accordingly, it is often desirable to reinforce the portion **150** of the tissue **152** to be cross-pinned within the bone tunnel. This may be accomplished in numerous ways well known to those skilled in the art. One such alternative, representatively shown in FIG. **43**, is to "whip stitch" the portion **150** of the tissue **152** which is to be cross-pinned within the bone tunnel. This creates a braid-enclosed, substantially solid mass **160** adapted to receive the rods **158**, and adds the strength of the numerous passes of the cord-like material **162**, extending

through the tissue as used to form the "whip stitch", to alleviate the tear-out problem referred to above. In addition, "whip stitching" is well understood by surgeons, and relatively easy to do. Therefore, this alternative avoids certain complications which may arise during the harvesting of tissue grafts with bone blocks attached; avoids trimming bone blocks to fit bone tunnels during surgical procedures; and provides a simple, fast and efficient way to cross-pin the tissue in a bone tunnel, with minimal added trauma to the patient.

As noted above, the foregoing procedures may also be used to secure artificial grafts in the bone tunnel, i.e., grafts comprising an artificial prosthetic device not harvested from the body. In such a case, it may or may not be desirable to fold the graft back upon itself one or more times, in the manner shown in FIGS. **41-43**, prior to cross-pinning.

Similarly, a portion **150** of a piece of tissue **152** may be fixed in a bone tunnel by positioning a bio-absorbable rod **163** diametrically across the bone tunnel **164**, and thereafter pulling the portion **150** of the piece of tissue **152** into an open end of the bone tunnel, around the rod **163** and back out the same open end of the bone tunnel. More particularly, as best seen in FIGS. **44-51**, it has been found that the positioning of a bio-absorbable rod **163** diametrically across bone tunnel **164** is best accomplished with a trocar/sleeve combination **171** such as that illustratively shown in FIGS. **15-17**. This is because in any alternative wherein a means such as a sharpened k-wire, trocar or the like is used without an accompanying sleeve to form an opening through the bone **166**, through the bone tunnel **164**, and into the bone **166** on the opposite side of the bone tunnel **164**, it is difficult to remove the hole-forming device and to replace it with a rod **163**. Typically, the rod **163** will pass through the opening **168** (FIG. **49**) and through the bone tunnel **164** easily, however, it is often not as easy to locate and engage opening **170** on the other side of bone tunnel **164** with the forward end of rod **163**.

Accordingly, in the practice of this alternative, it is preferred that a trocar/sleeve combination **171** be drilled in the manner discussed in detail above into bone **166**, transversely to the longitudinal axis **172** (FIG. **44**) of bone tunnel **164**, diametrically through bone tunnel **164**, and into bone **166** on the opposite side of bone tunnel **164** (see FIGS. **44** and **45**). Thereafter, the trocar **171a** is removed from sleeve **171b**, and a bio-absorbable rod **163** is inserted into sleeve **171a** so as to occupy a position extending across bone tunnel **164** (see FIGS. **46-48**). Sleeve **171b** is then removed from bone **166** and rod **163**, leaving rod **163** extending from opening **168**, diametrically across bone tunnel **164** and into opening **170** (see FIG. **49**).

At this point in the procedure, or earlier if desired, one end **175** of a length of cord-like material, such as suture **173**, is secured to an end **174** of piece of tissue **152** (FIG. **50**). The other end **176** of the length of cord-like material **173** is then threaded into an open end **178** of bone tunnel **164**, and thence around rod **163**, and then back out open end **178** of bone tunnel **164** (see FIG. **50**). Finally, the free end **176** of the cord-like material **173** is pulled so as to draw portion **150** of piece of tissue **152** into open end **178** of bone tunnel **164**, around bio-absorbable rod **163**, and back out open end **178** of bone tunnel **164**. Tissue portion **150** thus assumes a generally U-shape, having its closed end slidably secured in bone tunnel **164** by bio-absorbable rod **163**, and its free ends extending outwardly from the same open end **178** of bone tunnel **164** (see FIG. **51**).

As noted above, the foregoing procedure may also be used to secure artificial grafts in the bone tunnel, i.e., grafts comprising an artificial prosthetic device not harvested from the body.

Still further, it has been found that, in practice, bone blocks are relatively hard. This is frequently the case where the bone block is formed out of cortical bone. In addition, it can also sometimes be relatively difficult to drill a trocar/sleeve combination through bone 166, particularly where bone 166 comprises a substantial layer of cortical bone. Consequently, it can be difficult to drill a trocar/sleeve combination (see, for example, FIG. 55) through the bone, and into and/or through the bone block. In addition, even if this drilling is successfully accomplished, the bone block may fracture, as shown, for example, in FIGS. 52 and 53. In this respect it is noted that the possibility of bone block fracture may be reduced by reducing the diameter of the trocar/sleeve combination, and hence the resulting hole through the bone block, but this may in turn lead to an increase in the possibility of rod breakage when a load is applied to the graft ligament.

Two alternatives have been developed to address these problems.

In the first of these alternatives, best seen in FIG. 54, the solution utilizes the facts that (1) a bone block is significantly stronger in compression than it is in tension, and (2) a larger diameter rod will provide a stronger bone block fixation in a bone tunnel if bone block fracture is not an issue. Specifically, the bone block 200 is located at substantially closed end 202 of substantially blind bone tunnel 204, with its associated tissue graft 206 extending outwardly from the open end 208 of the substantially blind bone tunnel 204. It will be understood that a guide hole 201 may extend through substantially closed end 202 of bone tunnel 204 so as to allow bone block 200 to be drawn into bone tunnel 204 by a cord-like element 203, or otherwise located in bone tunnel 204 as discussed hereinabove. A rod 208, as much as 30% larger in diameter than a rod suitable for emplacement through bone block 200, is then located diametrically across bone tunnel 204 adjacent to proximal end 210 of bone block 200. In this case, rod 208 is positioned utilizing the same method as described above with regard to the threading of a portion of a piece of tissue over a rod extending diametrically through a bone tunnel (see FIGS. 44–51). Also, the rod 208 may pass through the tissue graft 208, or not, as desired. The result is that bone block 200 is reliably fixed in bone tunnel 206 between substantially closed tunnel end 202 and rod 208.

The second of the above-mentioned alternatives proceeds from the premise that if the sleeve does not have to extend into or through the bone block, a significantly larger diameter rod may be used with a corresponding increase in the strength of the fixation of the bone block in the bone tunnel. This alternative is representatively shown in FIGS. 56–63, which will be referred to specifically below.

In this case, the trocar/sleeve combinations 210 (see FIGS. 15–17 and 55) are drilled through the skin and into the bone in the same manner as discussed in detail above, and the bone block is located in the bone tunnel such that the various elements reside in a configuration generally as depicted in FIG. 22. At this point, the trocars are disengaged from the sleeves, the bone block is pulled up into the bone tunnel (FIG. 23), and rods are inserted through (i) the sleeves and (ii) the bone located between the distal ends of the sleeves and the bone tunnel, and then into the bone block.

The latter insertion step may be accomplished in any one of several different ways. For example, a second, longer trocar 212a, 212b may be inserted into each of the sleeves 214a, 214b and either drilled (FIG. 57) or tapped (FIG. 58) through the bone 216 located between the distal ends 218a,

218b of the sleeves 214a, 214b, and then into the bone tunnel 220 and into the bone block 222. Thereafter, one of the longer trocars 212 is removed (FIG. 59), and a metal, plastic, ceramic or bio-absorbable rod 224a is inserted into the bone and the bone block through the sleeve (FIG. 60). This is followed by the removal of the other longer trocar 212 (FIG. 61) and the insertion of another rod 224b into the bone and bone block through the second sleeve (FIG. 62). Finally, the sleeves are removed from the patient (FIG. 63).

In the last discussed alternative, the longer trocars 212a and 212b are commonly stepped, e.g., in the manner shown in FIG. 24. More particularly, the longer trocars 212a commonly include a distal portion 230 having a smaller transverse cross-sectional diameter than their proximal portion 232, and define a distally-facing radial shoulder 234 at the joiner of their proximal and distal portions. In this way, the extent of trocar penetration beyond the distal ends of the sleeves is controlled by pre-selecting the axial length of the distal portion of the longer trocars. More specifically, the longer trocars are allowed to penetrate beyond the distal ends of the sleeves only to the point at which their distally-facing radial shoulders engage either the bone at the distal ends of the sleeves, or a radially-disposed, inward projection 236 formed on the sleeve side wall (FIG. 65).

Alternatively, rigid rods 224a, 224b may be driven through the sleeves 214a, 214b, through the bone 216 located between the sleeves and the bone tunnel 220, and then into the bone block 222 directly. This may be accomplished by, preferably, pointing or rounding the distal ends of the rods 224a, 224b, inserting the rods into the sleeves 214a, 214b, and using a plunger shaft 238 and tapping means 240 to drive the rods into position through the bone and into the bone block (FIG. 66).

It further has been found, that in the interlocking trocar/sleeve assembly shown in FIGS. 15–17 and 55, the radial shoulder 242 (FIG. 55), formed by the distal end of the sleeve proximally of the pointed distal end 224 of the trocar extending distally thereof, can be a significant impediment to the passage of the interlocked trocar/sleeve combination into bone. Indeed, in practice, this shoulder, while normally only about 0.005 to 0.010 inch in radial thickness, has been noted to cause burning of the bone as the trocar/sleeve combination is advanced through the bone toward the bone tunnel. To correct this problem, the distal edge 242 of the sleeve could be bevelled at an angle substantially equal to that of the adjacent trocar point 244 (see FIG. 67). This is not preferred, however, in view of the variations in machining tolerance commonly acceptable in the art in the formation of bevelled edges and trocar points. In particular, the chance of an exact mating of the trocar point with a bevelled sleeve end is unlikely. Hence, the bone burning problem, and more generally the problem of the resistance to penetration of the trocar/sleeve combination into the bone, are still present in the embodiment shown in FIG. 67, albeit to a perhaps smaller degree than in the FIG. 55 embodiment.

To solve this basic problem, it has been found that the distal end 246 of the sleeve 248 should be slanted at an angle of approximately 15° proximally relative to a plane 250 located normal to the longitudinal axis 252 of the sleeve (see FIG. 68). In the resulting construction of the trocar/sleeve assembly, the trocar point 256 drills into the bone in the same manner as previously described, while the slanted distal end 246 of the sleeve 248 cuts into the sidewall of the hole formed by the trocar point, instead of rotating flat against the bone surrounding the hole being formed by the trocar. As a practical matter, this alternative is deemed to be of significant importance, inasmuch as the ease of use of the

methods and apparatus described herein affects their commercial utility. A bone drill which does not exhibit a tendency to bind, and/or to burn the bone during use, is significantly more desirable than a bone drill which does bind or burn the bone during use.

Accordingly it will be understood that, currently, one preferred method of practicing the present invention includes the following steps:

- (1) drilling at least two trocar/sleeve assemblies, of the type depicted in FIG. 68, into the bone to a position similar to that shown in FIG. 22 (note: this may be accomplished by sequentially and separately mating a single trocar with each sleeve and drilling that assembly into the bone);
- (2) removing the trocar(s) from the sleeves so as to leave the sleeves extending through the skin and into the bone, but not intersecting the bone tunnel;
- (3) removing the rack assembly (see element 52 in FIG. 21) from the sleeves and the bone tunnel;
- (4) locating a bone block in the bone tunnel in alignment with axial projections of the sleeves;
- (5) using a first, elongated, stepped trocar (see FIG. 64) to drill through the bone between the distal end of the first sleeve and the bone tunnel, through the bone block, and a pre-selected distance into the bone on the opposite side of the bone tunnel;
- (6) with the first, elongated stepped trocar extending through the bone and the bone block, using a second, elongated stepped trocar to drill through the bone between the distal end of the second sleeve and the bone tunnel, through the bone block, and a pre-selected distance into the bone on the opposite side of the bone tunnel;
- (7) removing the second trocar from the bone, the bone block and the second sleeve;
- (8) inserting a rigid rod (of bio-absorbable, or non-bio-absorbable, material) through the second sleeve to a position wherein it extends through the bone block and engages openings on opposite sides of the bone tunnel as formed by the second elongated stepped trocar;
- (9) removing the first trocar from the bone, the bone block and the first sleeve;
- (10) inserting another rigid rod (of bio-absorbable, or non-bio-absorbable, material) through the first sleeve to a position wherein it extends through the bone block and engages the openings on opposite sides of the bone tunnel as formed by the first elongated stepped trocar; and
- (11) removing the first and second sleeves from the patient.

The last mentioned alternatives also provide advantageous settings for the use of certain modifications to the above-described cross-pinning apparatus. For example, in the embodiment of the rack assembly discussed above wherein the cannulated sleeve 58 has an enlarged head 62 adapted for location in a bone tunnel transversely of the trocar/sleeve assemblies which are being drilled into the surrounding bone (FIGS. 19–21), a flattened head 258 (FIG. 69) defining a window 260 therethrough might be used in place of the enlarged head 62. In such a case, the flattened head 258 would extend substantially diametrically across the bone tunnel 262 in a plane transverse to an axial projection of the trocar/sleeve assemblies 264 being drilled into the bone. Further, the window 260 would be so disposed that the trocar/sleeve assemblies (or the trocars alone) could pen-

trate into the bone tunnel, through the window 260 in the head of the cannulated sleeve 266, and then into the bone on the opposite side of the bone tunnel.

More particularly, as shown in FIG. 69, this embodiment of the present invention is useful in any situation in which it is desired to form diametrically opposed openings in the sidewall of a bone tunnel. Particular examples of such situations include those wherein the length of the sleeve and the length, and rigidity, of the rods are such that they may be relied upon to ensure that a rod entering the bone tunnel from the drill means entry side thereof will be maintained in alignment with, and engage, the opening on the other side of the bone tunnel. Thus, those cases mentioned above wherein a rigid rod is passed through an object in a bone tunnel may find this alternative beneficial.

Finally, it is to be understood that the interlocking trocar/sleeve assemblies discussed hereinabove have numerous other uses beyond the cross-pinning of objects in bone tunnels. One such illustrative use is in the placement of absorbable, or non-absorbable, pins across bone fractures so as to assist in maintaining broken bones in a desired healing relationship after fracture reduction procedures have been completed. As depicted in FIGS. 70–74, this method follows the now well-understood steps of drilling a trocar/sleeve assembly into the desired position in bone, removing the trocar, inserting a rod into the sleeve, and then removing the sleeve from the bone and the rod.

Other illustrative uses of the devices and concepts of the present invention may include, among others, the removal of tissue from the interior of bones, and/or the delivery of other things into the interior of a bone, such as other devices or prostheses, drugs, bone graft material, substitute bone marrow, and so on.

Numerous further variations, alterations, modifications and other derivations of the present invention will occur and/or become obvious to those skilled in the art in view of the foregoing detailed description of the preferred embodiments of the present invention. Accordingly, it is to be understood that the foregoing specification and the appended drawings are intended to be illustrative only, and not as limiting of the invention.

What is claimed is:

1. A method for deploying an element in bone, said method comprising the steps of:

providing a trocar and trocar sleeve combination comprising a hollow sleeve having a distal end, a proximal end and a longitudinal length, wherein the interior of said sleeve defines a substantially cylindrical longitudinal passageway between said proximal end and said distal end, and a pair of opposing grooves in the sidewall of said passageway, said grooves extending respectively from said proximal end of said sleeve to opposing closed ends spaced from said distal end of said sleeve; and

a trocar including a shaft having a transverse cross-section adapted to be slidingly received in said passageway, a pointed distal end adapted for drilling into bone and a pair of opposing projections adapted to be slidingly received in said grooves when said shaft is located in said passageway such that the extension of said pointed end out of said distal end is limited according to the longitudinal distance between said pointed end and said projections in relation to the longitudinal spacing of said closed groove ends from said distal end of said shaft;

whereby when said trocar is inserted into said passageway, the resulting trocar and trocar sleeve com-

21

bination may be rotated and drilled distally into bone as a unit and said trocar may be slidably, proximally removed from said sleeve;

drilling said trocar and trocar sleeve combination into the bone;

removing said trocar from said trocar sleeve;

inserting said element into said bone through said passageway of said sleeve; and

removing said sleeve from said element and said bone.

2. A method according to claim 1 further comprising the steps of:

providing a second trocar including a distal portion having a first transverse cross-section and a proximal portion having a second transverse cross-section, said first transverse cross-section being smaller than said second transverse cross-section, and a distally facing shoulder at the joinder of said first and second transverse cross-sections,

and after removing said trocar but before inserting said element, drilling said second trocar into said bone at the distal end of said sleeve a longitudinal length substantially equal to said proximal portion of said trocar, such that said shoulder abuts said bone at said distal end of said sleeve.

3. A method according to claim 2 wherein the longitudinal passageway through said sleeve includes internal stop means adapted to engage said trocar shoulder so as to further limit the longitudinal travel of said second trocar through said sleeve and into said bone at said distal end of said sleeve.

4. A method according to claim 2 wherein said bone defines a bone tunnel, said trocar and trocar sleeve combination penetrates into said bone transversely of said bone tunnel but not into said bone tunnel, a bone block is located in said bone tunnel in axial alignment with said trocar and trocar sleeve combination, and said second trocar penetrates through the bone between the distal end of said sleeve and said bone tunnel and into said bone block, and said element comprises a rod.

22

5. The method of claim 2 wherein said element is selected from the group consisting of substantially rigid rods, medications, prosthetic materials and substitute tissue.

6. The method of claim 4 wherein said rods are formed of bio-absorbable material.

7. The method of claim 6 wherein said bioabsorbable material is selected from the group consisting of polylactic acid, polyglycolic acid and polydioxanone.

8. The method of claim 4 wherein said rod is formed of a material selected from the group consisting of substantially rigid metals, plastics, and ceramics.

9. The method of claim 4 wherein said second trocar penetrates through said bone block and back into said bone.

10. The method of claim 4 wherein said second trocar does not penetrate all the way through said bone block.

11. The method of claim 4 wherein said bone comprises a reduced fracture, said element comprises a rigid rod, and said trocar and trocar sleeve combination extends across said reduced bone fracture.

12. The method in accordance with claim 1 wherein said trocar sleeve includes a collar portion defining a portion of said passageway and said opposing grooves are defined by said collar portion, and wherein the step of inserting said trocar into said trocar sleeve includes sliding said trocar projections into said grooves in said collar portion.

13. The method in accordance with claim 12 wherein said pair of opposing projections comprise at least one pin extending radially outwardly from said trocar, and wherein sliding said trocar projections into said grooves comprises sliding said at least one pin into said grooves.

14. The method in accordance with claim 1 wherein said opposing grooves extend radially from said passageway, and said projections extend radially outwardly from said trocar.

15. The method in accordance with claim 14 wherein said grooves are elongated linear grooves open at inner ends thereof and closed at outer ends thereof.

* * * * *