



US006083407A

**United States Patent** [19]

[11] **Patent Number:** **6,083,407**

**Kerfoot**

[45] **Date of Patent:** **Jul. 4, 2000**

[54] **MICROPOROUS DIFFUSION APPARATUS**

OTHER PUBLICATIONS

[76] Inventor: **William B. Kerfoot**, KV Associates, Inc. P.O. Box 574, Falmouth, Mass. 02540

“Hydrocarbon Contaminated Soils”, E.J. Calabrese et al., Lewis Publishers, vol. 111, 1993, pp. 520–528.

“A Simple Test to Determine the Bubbling Radius and Bubble Conductivity of an Aquifer”, Technical Publication #93, KVA Analytical Systems, pp. 1–14.

[21] Appl. No.: **09/220,401**

[22] Filed: **Dec. 24, 1998**

*Primary Examiner*—David A. Simmons  
*Assistant Examiner*—Betsey J. Morrison  
*Attorney, Agent, or Firm*—Fish & Richardson, P.C.

**Related U.S. Application Data**

[63] Continuation of application No. 08/756,273, Nov. 25, 1996, Pat. No. 5,855,775, which is a continuation-in-part of application No. 08/638,017, Apr. 25, 1996, abandoned, which is a continuation-in-part of application No. 29/038,499, May 5, 1995, abandoned.

[57] **ABSTRACT**

[51] **Int. Cl.**<sup>7</sup> ..... **C02F 1/78**

[52] **U.S. Cl.** ..... **210/747; 210/752; 210/760; 210/170; 210/192; 210/908; 405/128**

[58] **Field of Search** ..... 210/747, 752, 210/758, 760, 170, 192, 908; 405/128

Apparatus for active in situ multi-element gas sparging for bioremediation or physico-chemical degradation for removal of contaminants in a soil formation containing a subsurface groundwater aquifer or a substantially wet unsaturated zone, the multi-gas contained in bubbles, wherein the apparatus includes a plurality of injection wells extending to a depth of a selected aquifer; introducing an oxidizing agent comprising ozone mixed with ambient air to provide a multi-element gas by means of microporous diffusers, without applying a vacuum for extraction of stripped products or biodegradation by-products, wherein said diffusers form micro-fine bubbles containing said multi-element gas that oxidizes, by stripping and decomposition, chlorinated hydrocarbons from the aquifer and surrounding saturated soil formation into harmless by-products; also including a pump for agitating water in the well selecting microbubbles, injecting them into the aquifer and effective to alter the path of micro-fine bubbles through a porous solid formation whereby enhanced contact between the oxidizing agent contained in each said bubble by stripping pollutant from solution in ambient water into the mini-atmosphere of each bubble effective to increase the efficiency and speed of remediation of a site.

[56] **References Cited**

**U.S. PATENT DOCUMENTS**

5,205,927	4/1993	Wickramanayake	210/170
5,248,395	9/1993	Rastelli et al.	203/41
5,375,539	12/1994	Rippberger	110/238
5,389,267	2/1995	Gorelick et al.	210/758
5,403,476	4/1995	Bernhardt	210/170
5,425,598	6/1995	Pennington	405/118
5,472,294	12/1995	Billings et al.	405/128
5,698,092	12/1997	Chen	210/170

**FOREIGN PATENT DOCUMENTS**

03267196	11/1991	Japan .
2 185 901	8/1987	United Kingdom .

**24 Claims, 13 Drawing Sheets**

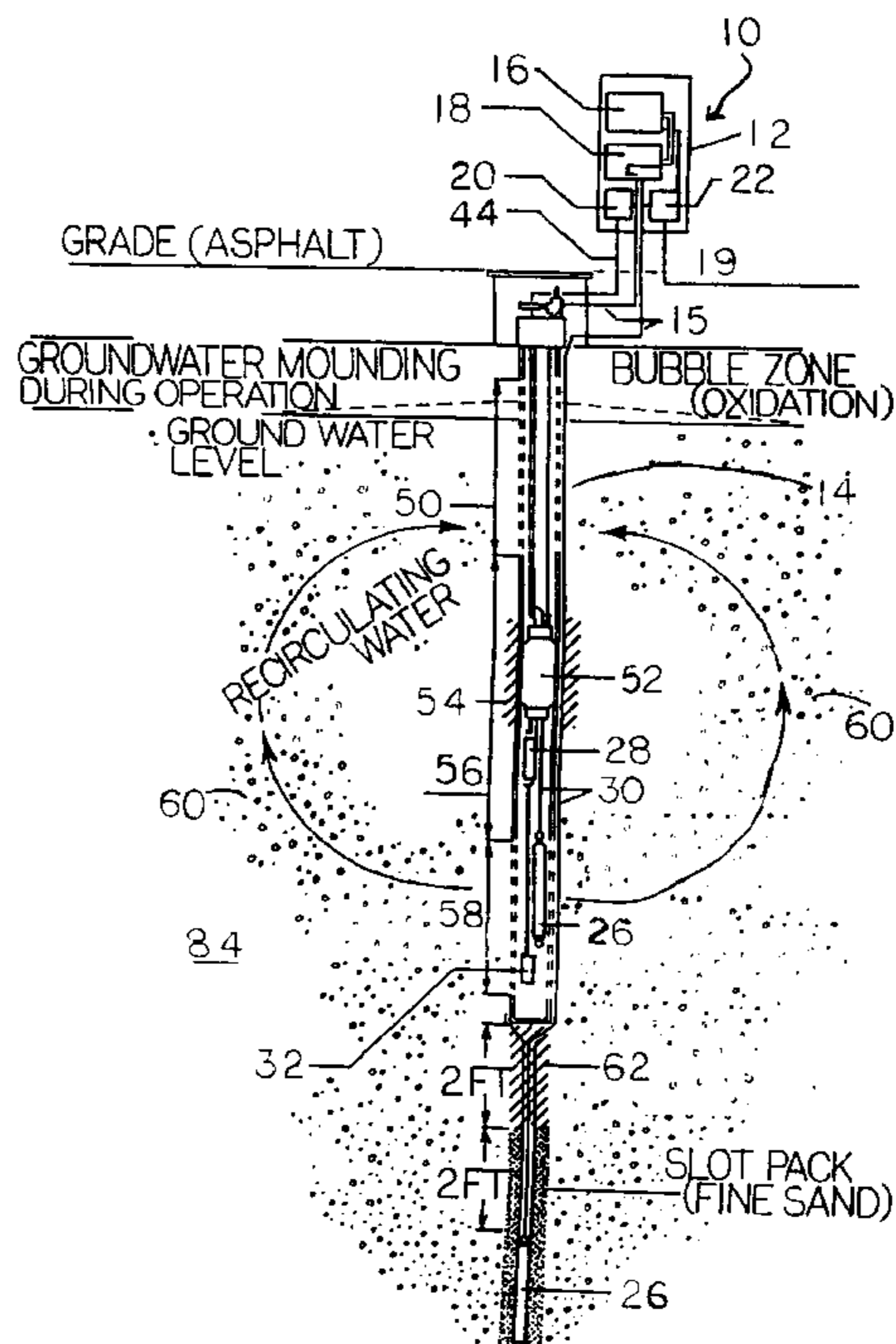



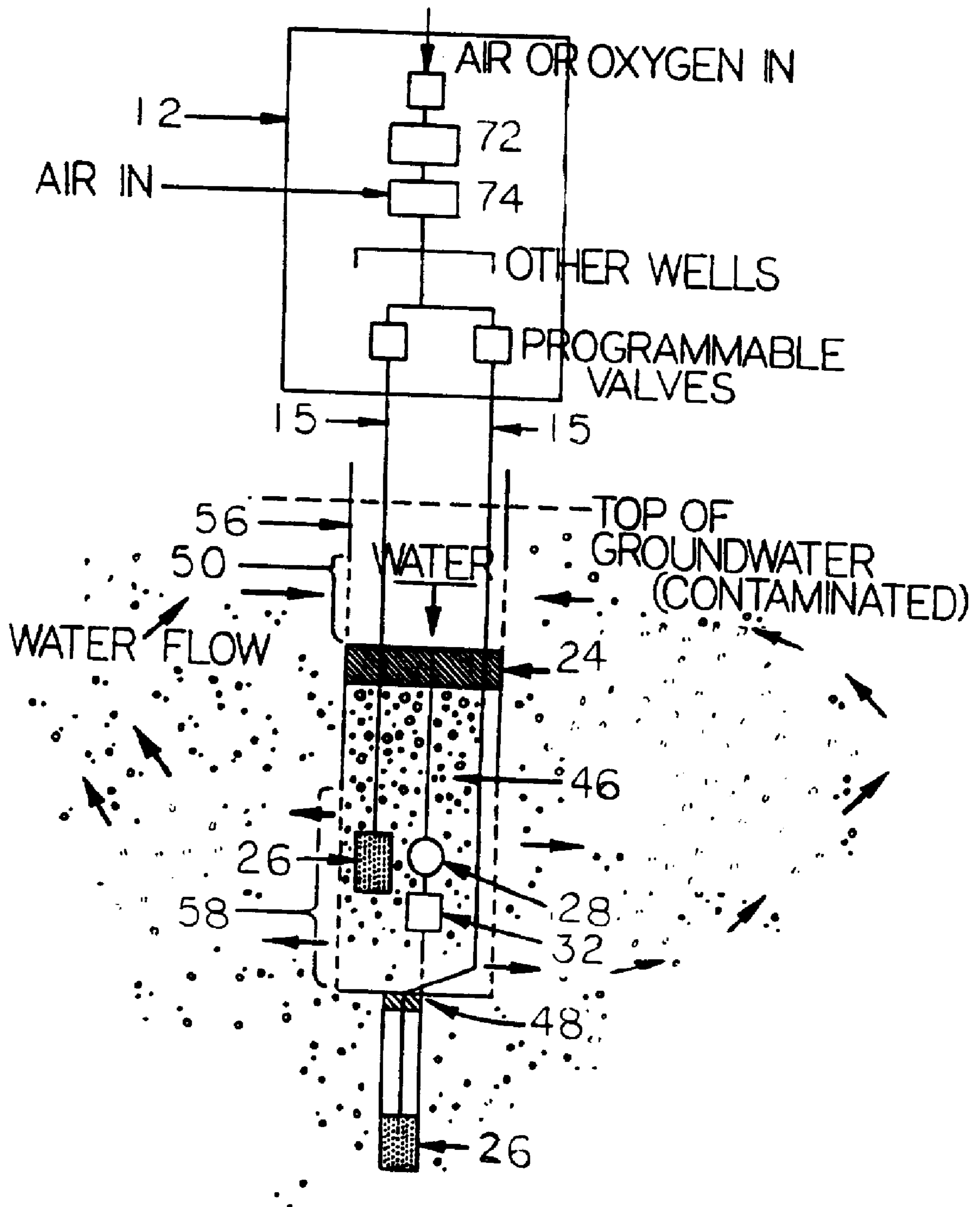

FIG. 2

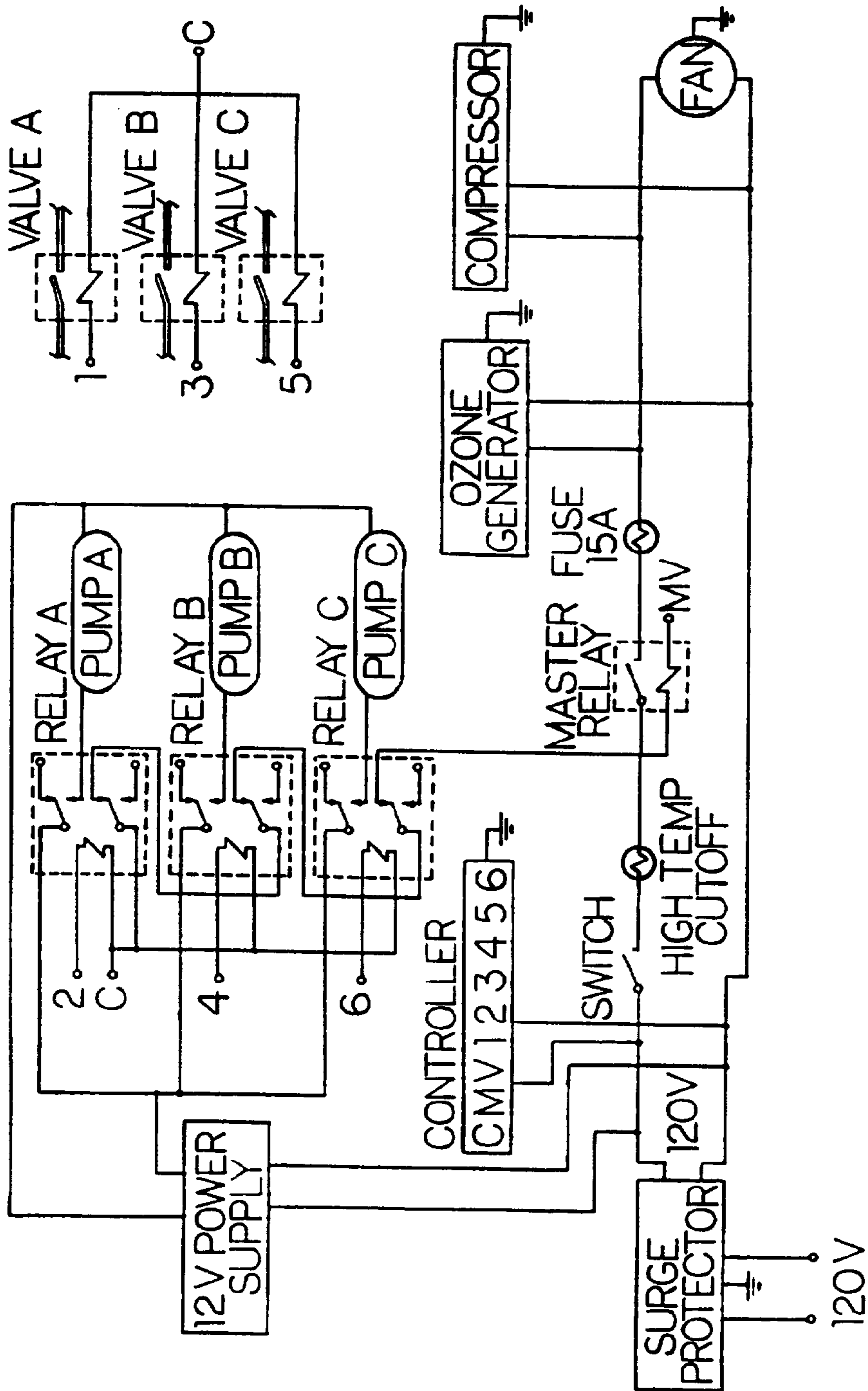
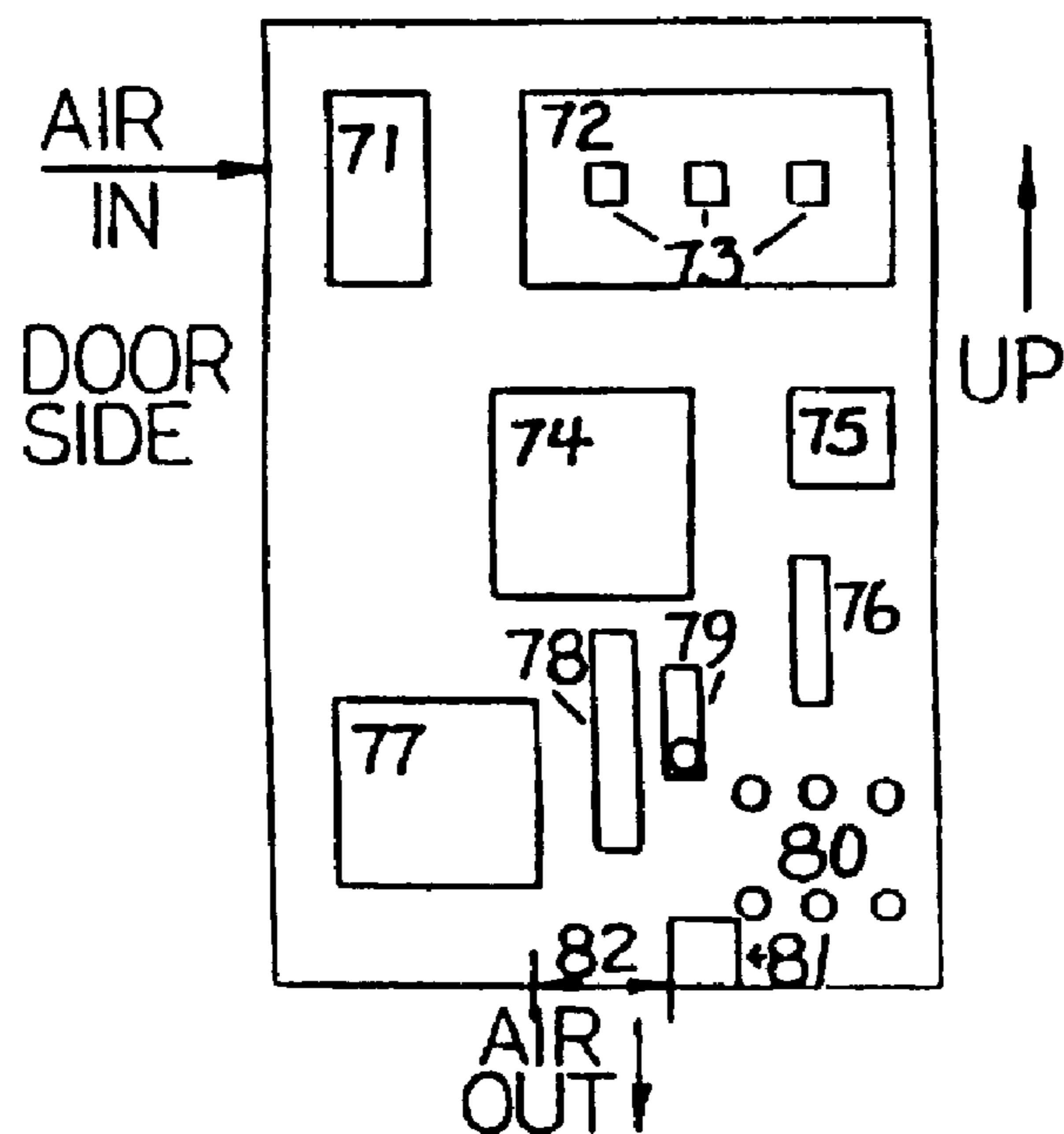

FIG. 3



- 71 AC TO DC POWER CONVERTER (OR TRICKLE CHARGED LEAD ACID BATTERY)
- 72 OZONE GENERATOR
- 73 WELL GAS RELAYS (3 WELLS SHOWN)
- 74 COMPRESSOR
- 75 MASTER RELAY
- 76 15A MAIN FUSE
- 77 PROGRAMMABLE TIMER-CONTROLLER
- 78 POWER STRIP
- 79 GAS REGULATOR AND PRESSURE GAGE
- 80 SOLENOID MANIFOLD (NUMBER DEPENDS ON SERIES AND NUMBER WELLS)
- 81 GROUND FAULT INTERRUPTOR
- 82 COOLING FAN

FIG. 4

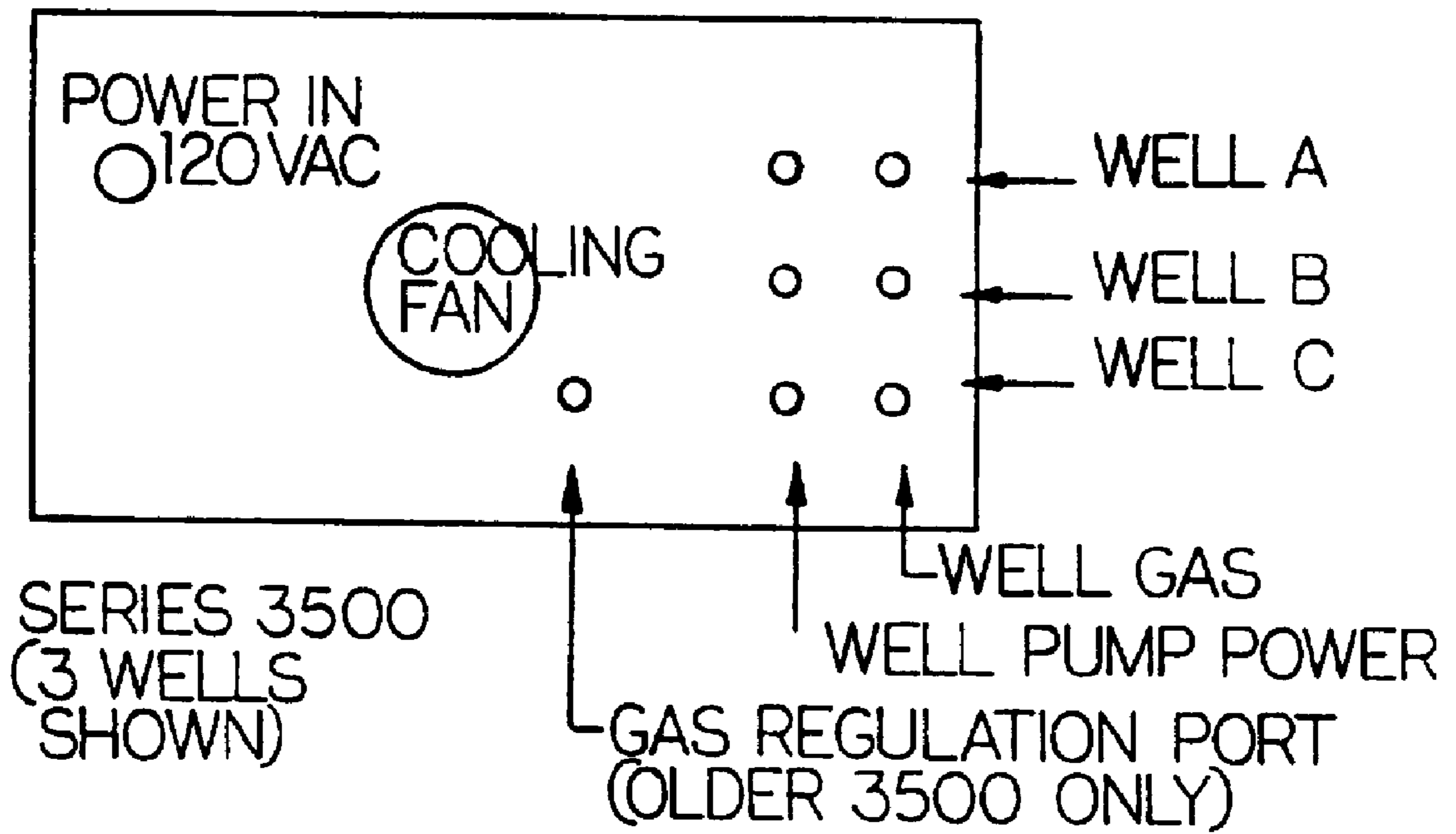

FIG. 5A

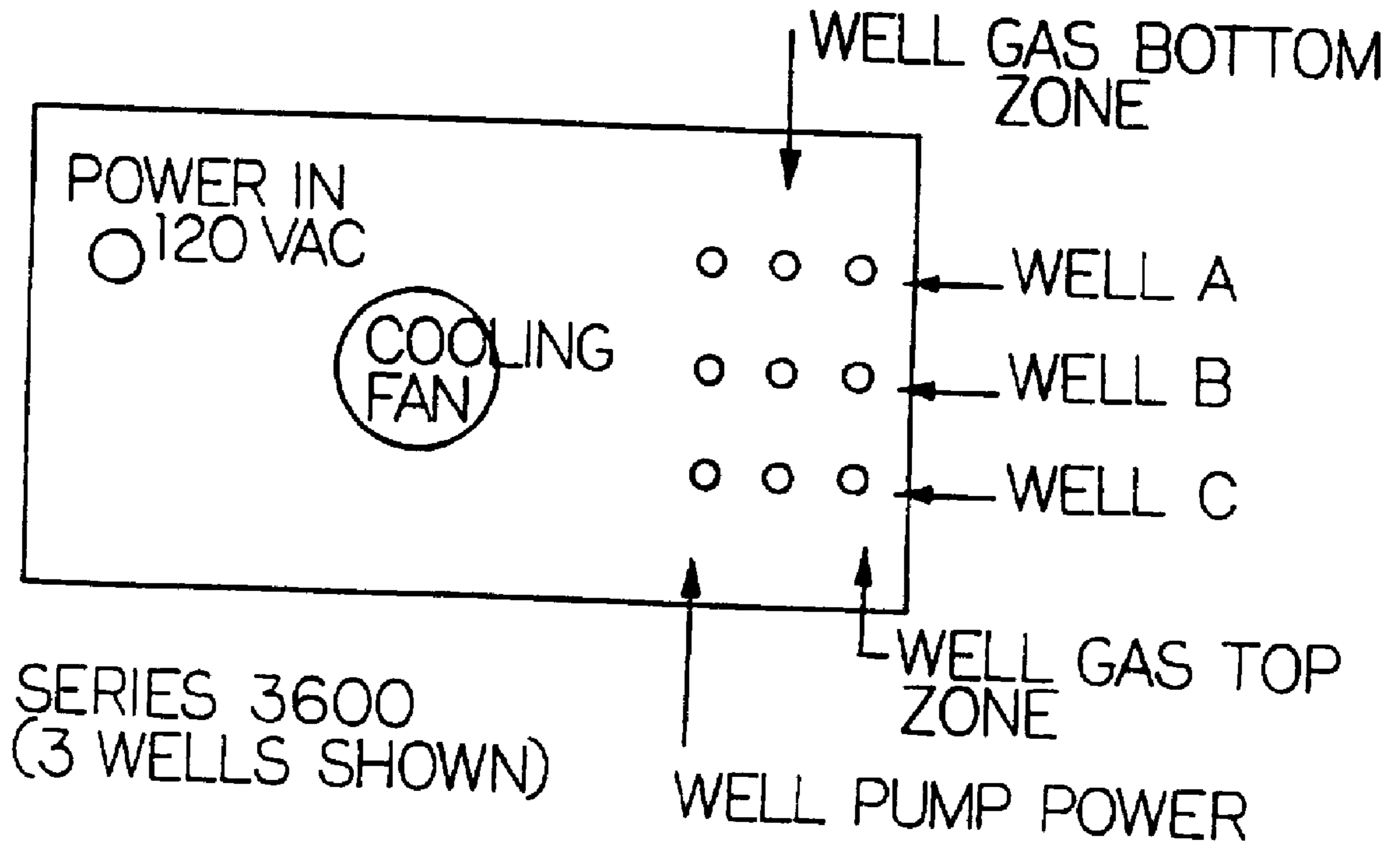

FIG. 5B

### C-SPARGER™ SYSTEMS - TYPICAL REMEDIATION SYSTEM CONFIGURATION

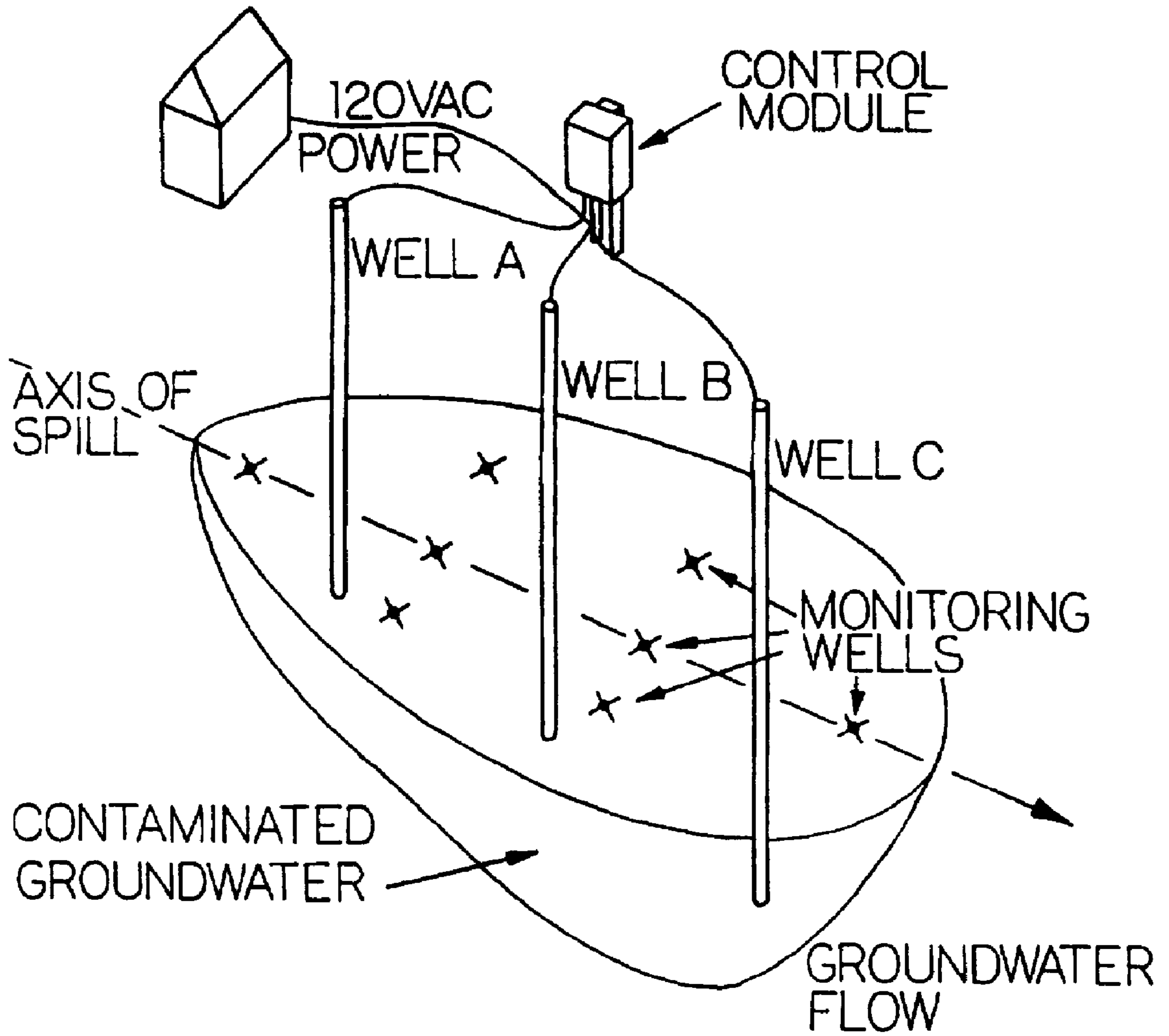

FIG. 6



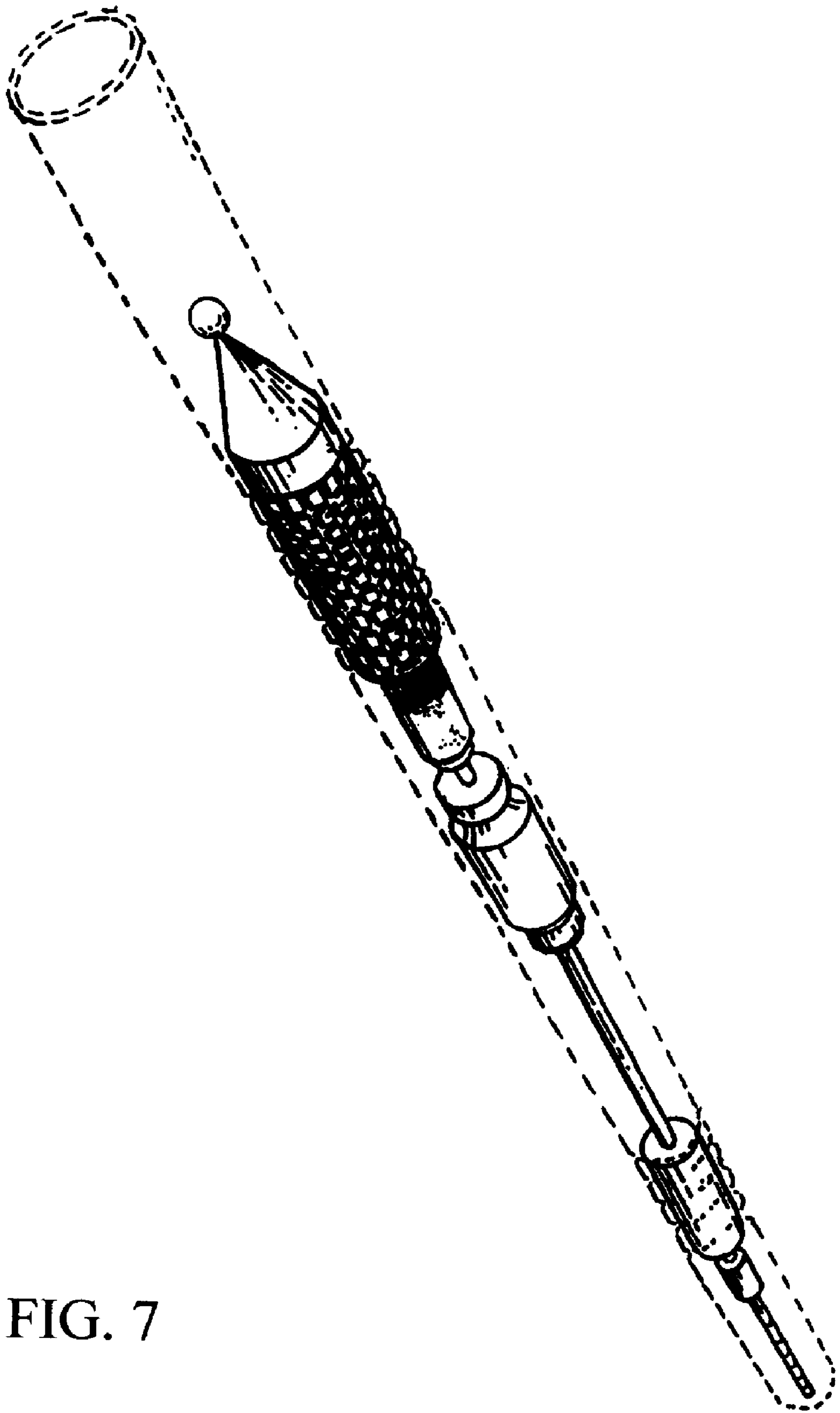

FIG. 7

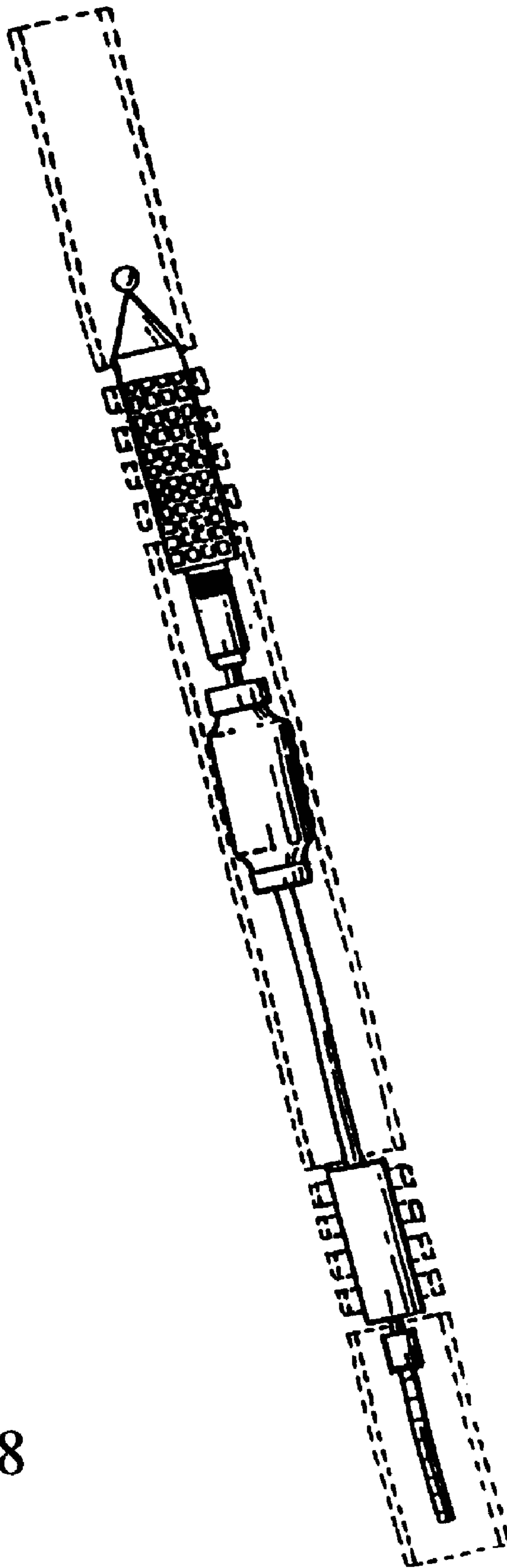

FIG. 8

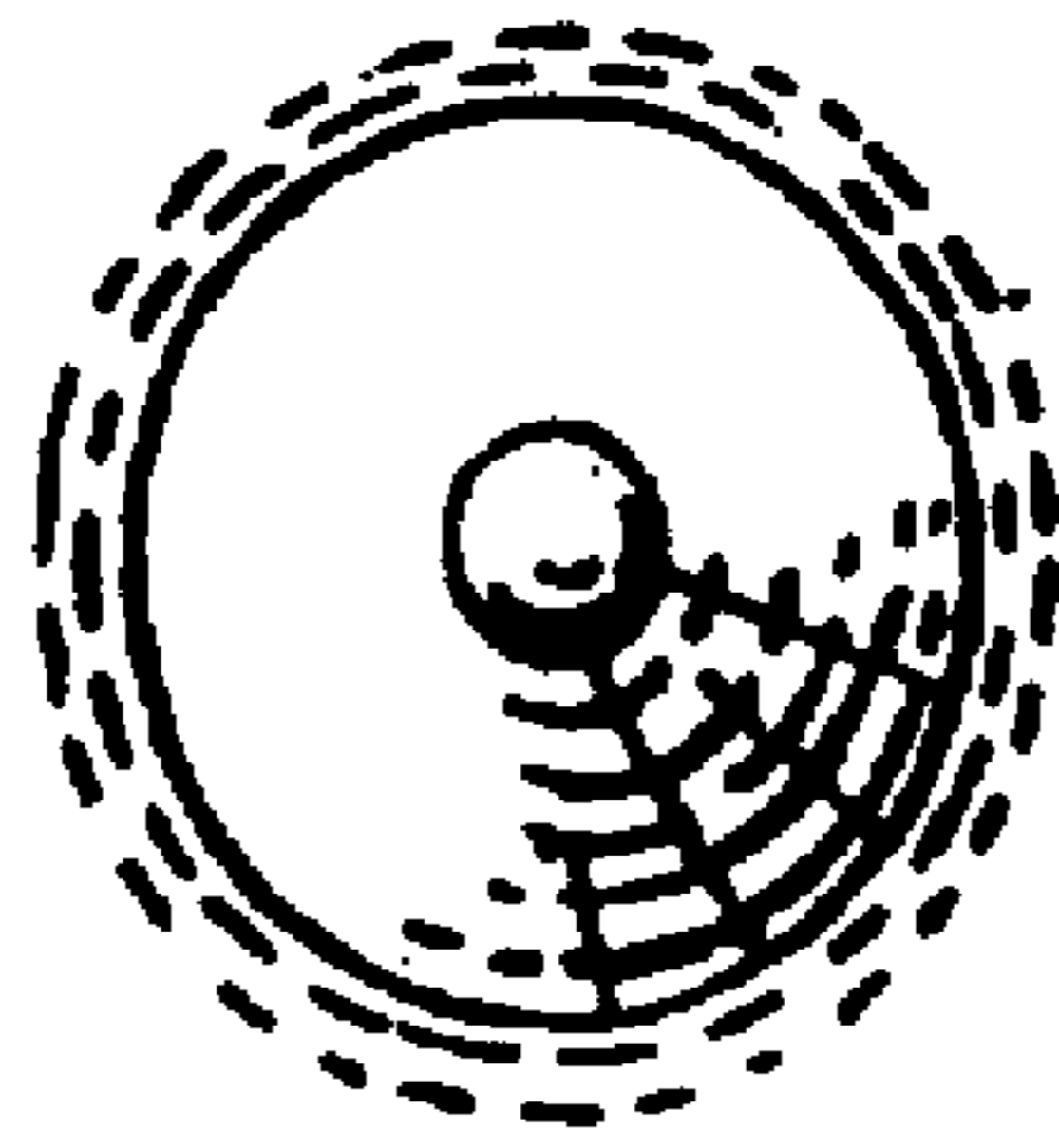

FIG. 9

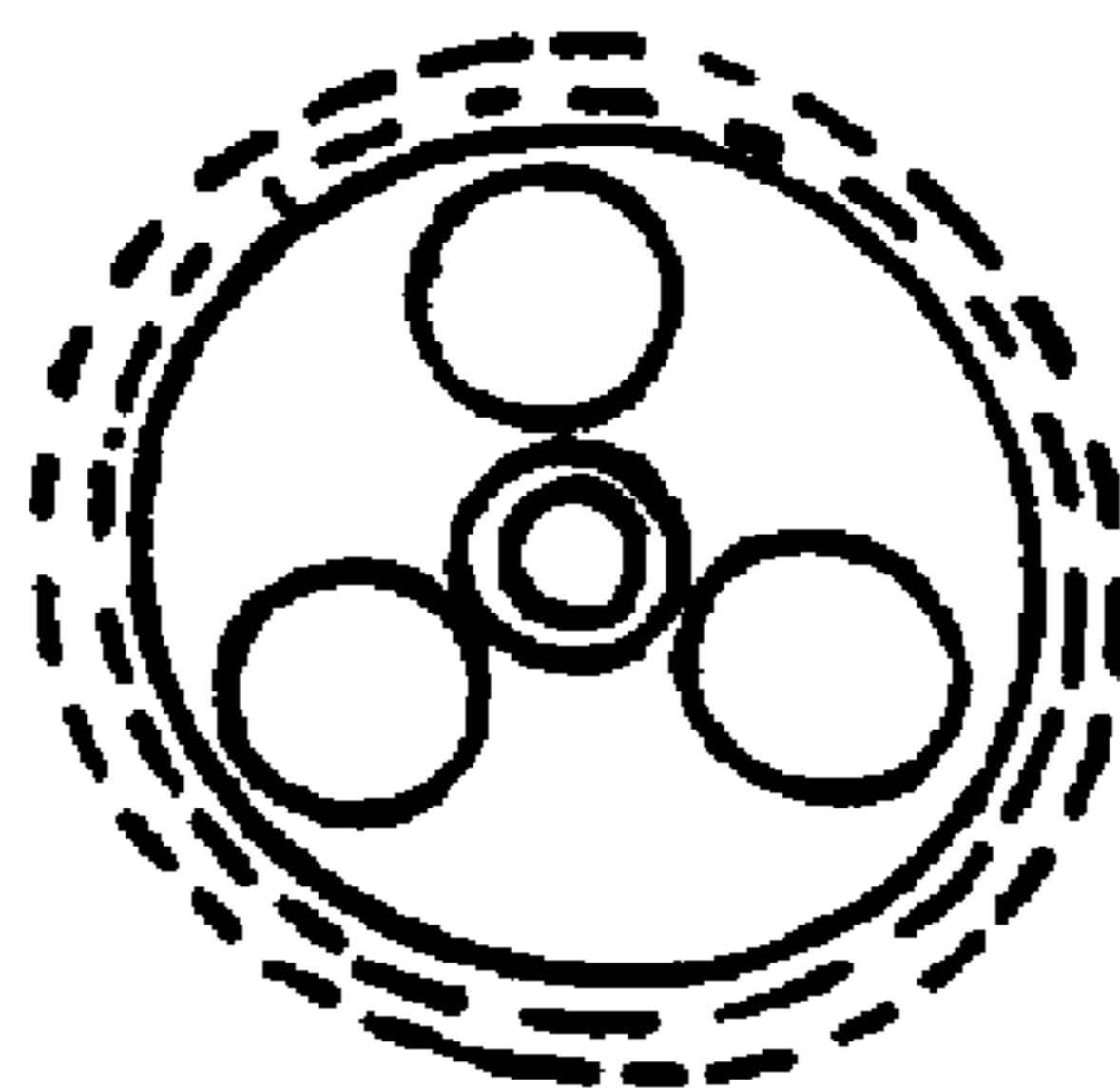

FIG. 10

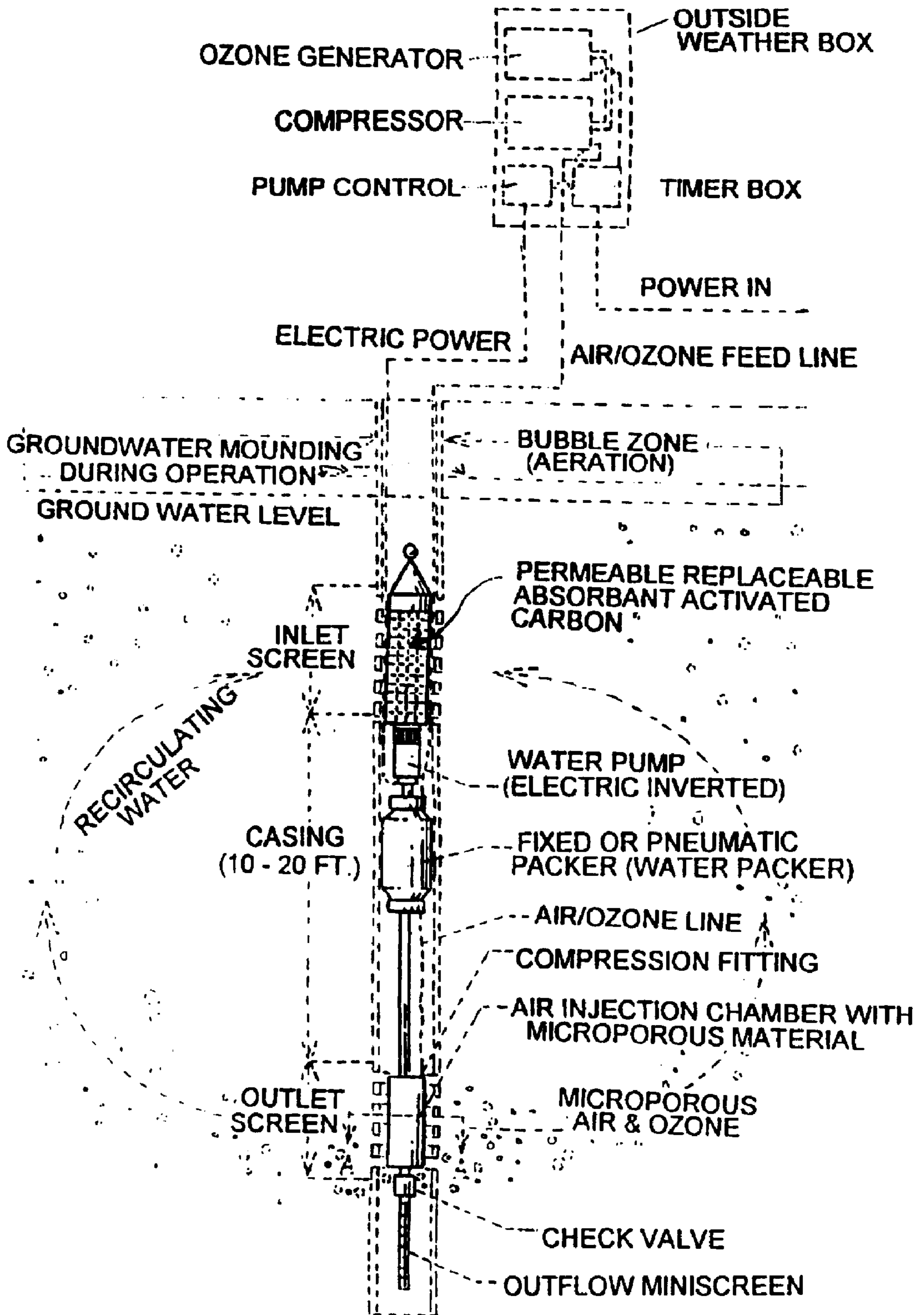

FIG. 11

PASS-THROUGH THREADED MICROPOROUS SPARGEPOINT<sup>®</sup> ASSEMBLY  
(ATTACHES TO TUBING BUNDLE)

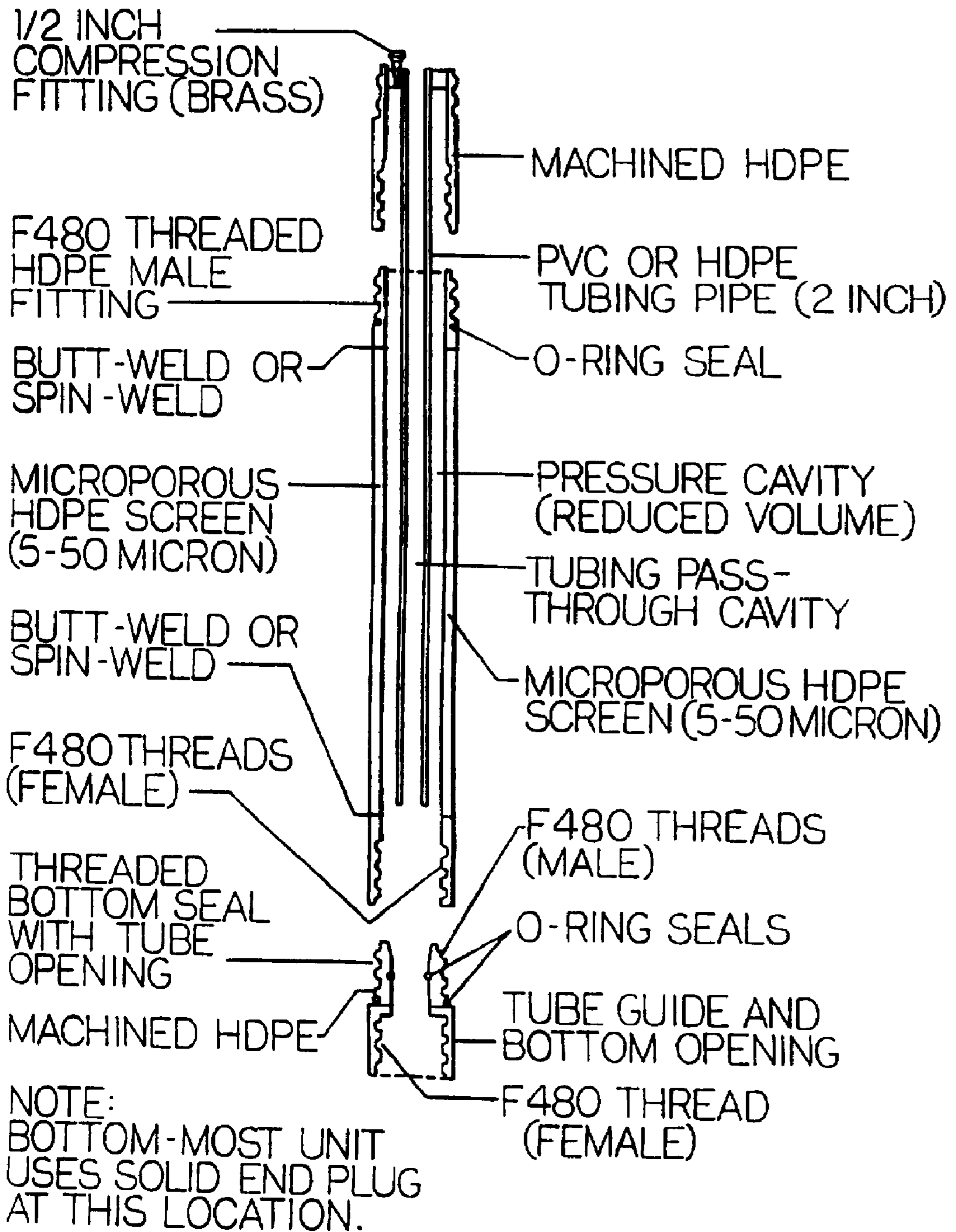

FIG. 12

**CONTROL MODULE**

	3500 Series	3600 Series
External Power	120V AC, 15 amp	120V AC, 15 amp
Well pumps Power	12V DC, power converter *	12V DC, power converter *
compressor	3/4 hp (not for continuous service)	3/4 hp (continuous OK)
Ozone Generator	ATS-250	VCX-2
Gas tubing	1/4 in.	3/8 in.
Box Size	28"x 20 x 11"	33"x 25 x 12"
Approx. Wt Control Mod.	73 lbs (M-3503)	100 lbs (M-3603)
Pump/gas Line Length (1 for each well)	100 ft.	100 ft.
<b>IN-WELL UNIT (Each well)</b>		
Fixed Packer	4-6 in.	4-6 in.
Spargepoint™ Top	1 in.	1 in.
Bottom	2 in.	—
Water Pump	XP-30ft	XP-30 ft.
Inlet & outlet Screens	10-20 slots/ft	10-20 slots/ft
Check valve water	one, 1/4 in.	one, 1/4 in.
Timer/Controller	PSCZ-600Z	PSCZ-900Z

\* current production, earlier units used a trickle charged lead acid battery

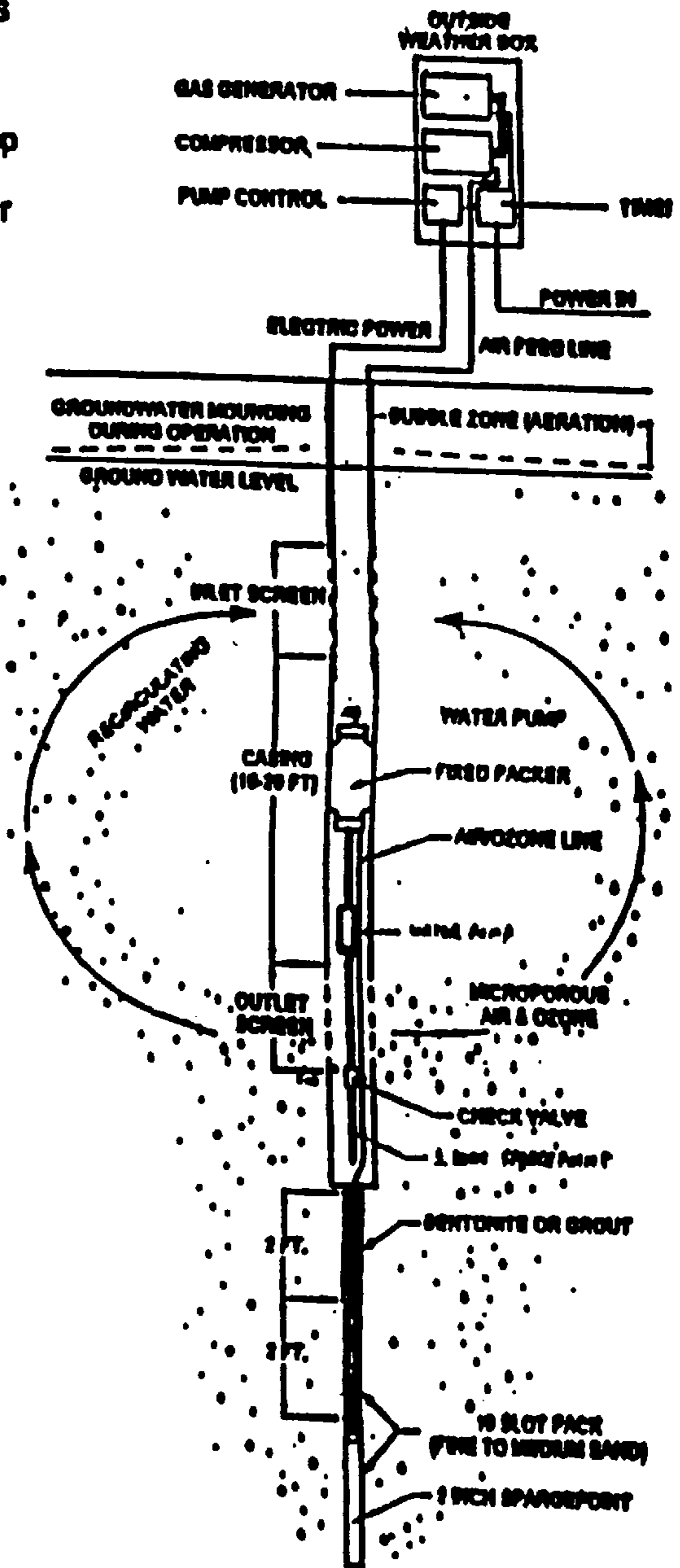

FIG. 13

**MICROPOROUS DIFFUSION APPARATUS**

This application is a continuation application of application Ser. No. 08/756,273 filed Nov. 25, 1996, now U.S. Pat. No. 5,855,775, issued Jan. 5, 1999, which was a continuation-in-part of application Ser. No. 08/638,017 filed on Apr. 25, 1996 (abandoned) which was a continuation-in-part of application Ser. No. 29/038,499 filed on May 5, 1995 (abandoned).

**BACKGROUND OF INVENTION****1. Field of Invention (Technical Field)**

The present invention relates to apparatuses for remediation of dissolved chlorinated hydrocarbons in aquifer regions by injecting micro-fine bubbles effective for active in situ groundwater remediation for removal of dissolved chlorinated hydrocarbon solvents and dissolved hydrocarbon petroleum products. Remediation of saturated soils may also be obtained by employment of the present invention.

**2. Background Prior Art**

There is a well recognized need to cleanup subsurface leachate plumes in aquifer regions and contaminated sites including in particular, dry-cleaning establishments and U.S. Military Air bases. Applicant is aware of prior art devices that have used injection of air to facilitate biodegradation of plumes.

However there has not been shown apparatus for remediating a site in a controlled manner of poorly biodegradable organics, particularly dissolved chlorinated solvents with micro-fine bubbles including a multi-gas oxidizing agent.

In fact the Federal Agency (EPA, KERR Environmental Laboratory, ADA, Oklahoma) responsible for review of clean-up procedures at Marine Corp Air Base at Yuma, Ariz. has determined that there are no prior references which disclose the use of the present invention and has ordered independent pilot tests to provide test results confirming the results previously obtained by the present invention.

U.S. Pat. No. 5,221,159, to Billings shows injection of air into aquifer regions to encourage biodegradation of leachate plumes which contain biodegradable organics together with simultaneous soil vacuum extraction.

U.S. Pat. No. 5,269,943, METHOD FOR TREATMENT OF SOILS CONTAMINATED WITH ORGANIC POLLUTANTS, to Wickramanayake shows a method for treating soil contaminated by organic compounds wherein an ozone containing gas is treated with acid to increase the stability of the ozone in the soil environment and the treated ozone applied to the contaminated soil to decompose the organic compounds.

U.S. Pat. No. 5,525,008, REMEDIATION APPARATUS AND METHOD FOR ORGANIC CONTAMINATION IN SOIL AND GROUNDWATER, to Wilson provides a method and apparatus for in-situ treatment of soil and groundwater contaminated with organic pollutants. It involves concentration of a reactive solution required to effect treatment of the contaminated area; injecting the reactive solution into one or more injectors that are inserted into the ground, sealed and positioned so as to assure flow and allowing reactive solution to flow through the contaminated area thereby reacting chemically. Preferably, the reactive solution is an aqueous solution of hydrogen peroxide and metallic salts.

In U.S. Pat. No. 5,178,755, UV-ENHANCED OZONE WASTEWATER TREATMENT SYSTEM, to LaCrosse ozonated liquid is mixed within a multi-stage clarifier system with wastewater to be treated and suspended solids are removed.

However, notwithstanding the teachings of the prior art, there has not been shown apparatus for remediating a site in a controlled manner of poorly biodegradable organics, particularly dissolved chlorinated solvents with micro-fine bubbles including an encapsulated multi-gas oxidizing agent. The present invention accomplishes this by employing microporous diffusers injecting multi-gas bubbles containing an ozone oxidizing agent into aquifer regions to in situ strip and rapidly decompose poorly biodegradable organics or to accelerate biodegradation of leachate plumes which contain biodegradable organics which overcomes at least some of the disadvantages of prior art.

**SUMMARY OF THE INVENTION**

The present invention relates to sparging apparatus for injection of oxidizing gas in the form of small bubbles into aquifer regions to encourage in situ remediation of subsurface leachate plumes.

In particular the present invention is directed to sparging apparatuses for employing microporous diffusers for injecting micro-fine bubbles containing encapsulated gas bubbles into aquifer regions to encourage biodegradation of leachate plumes which contain biodegradable organics, or Criegee decomposition of leachate plumes containing dissolved chlorinated hydrocarbons. The sparging apparatuses of the present invention, employing microporous diffusers for injecting an encapsulated oxidizing agent, are particularly useful in that the apparatuses promote extremely efficient removal of poorly biodegradable organics, particularly dissolved chlorinated solvents, without vacuum extraction of undesirable by-products of remediation and wherein remediation occurs by employing encapsulated oxidizing agent for destroying organic and hydrocarbon material in place without release of contaminating vapors.

Unlike the prior art, the contaminated groundwater is injected with an air/ozone mixture wherein micro-fine air bubbles strip the solvents from the groundwater and the encapsulated ozone acts as an oxidizing agent in a gas/gas reaction to break down the contaminates into carbon dioxide, very dilute HCL and water.

The present invention is directed to low-cost removal of dissolved chlorinated hydrocarbon solvents in contaminated soil and groundwater aquifers. A C-Sparger(tm) system employs microporous diffusers, e.g., Sparge Points (R) for producing micro-fine bubbles containing an oxidizing agent that decomposes chlorinated hydrocarbons into harmless byproducts. The C-Sparger (tm) also incorporates pump means for pumping the multi-gas oxidizing mixture through the microporous diffuser into groundwater in a soil formation; a bubble production chamber to generate bubbles of differing size, a timer to delay pumping until large bubbles have segregated from small bubbles by rise time, and a pump which forces the fine bubbles and liquid out into the formation. The pump means intermittently agitates the water in the well in which the system is installed which is effective to disturb the normal inverted cone-shaped path of the bubbles injected by the diffusers through the soil formation and disperses them in a random manner, ensuring improved contact between the oxidizing agent (contained in each bubble) by stripping the pollutant from solution in the water into the mini-atmosphere contained in each bubble. The pulsing action promotes movement of the bubbles through the porous formation. It is the in situ stripping action and maintenance of low solvent gas concentration in the bubbles which increases the efficacy and speed (and minimizes cost) of remediation of a site.

The apparatus of the present invention for removal of contaminants from soil and an associated subsurface groundwater aquifer using microporous diffusers promotes extremely efficient removal of poorly biodegradable organics, particularly dissolved chlorinated solvents, without vacuum extraction, and wherein remediation occurs by destroying organic and hydrocarbon material in place without release of contaminating vapors.

In the present invention the microporous diffusers and multi-gas system comprises oxidizing gas encapsulated in micro-bubbles generated from microporous diffusers matched to soil porosity. A unique bubble size range is matched to underground formation porosity and achieves dual properties of fluid like transmission and rapid extraction of selected volatile gases, said size being so selected so as to not be so small as to lose vertical mobility. In order to accomplish a proper matching, a prior site evaluation test procedure is devised to test effectiveness of fluid transmission at the site to be remediated.

The advantage of controlled selection of small bubble size promotes rapid extraction of selected volatile organic compounds, such as PCE, TCE, or DCE with an exceptionally high surface to gas volume ratio. The dual capacity of the small bubble production pulsed injection and rise time is matched to the short lifetime of an oxidative gas, such as ozone to allow rapid dispersion into predominantly water-saturated geological formations, and extraction and rapid decomposition of the volatile organic material. The unique apparatus of the present invention provides for extraction efficiency with resulting economy of operation by maximizing contact with oxidant by selective rapid extraction providing for optimum fluidity to permit bubbles to move like a fluid through media which can be monitored.

The use of microporous diffuser points provides a more even distribution of air into a saturated formation than the use of pressurized wells. A sparge system installed to remediate contaminated groundwater is made more cost-effective by sparging different parts of the plume area at sequenced times. Through the proper placement of sparge locations and sequence control, any possible off-site migration of floating product is eliminated. With closely spaced sparge points, water mounding is used to advantage in preventing any off-site escape of contaminant. The mounding is used to herd floating product toward extraction sites.

In the present invention, the microporous diffusers and multi-gas system, hereinafter referred to as C-Sparger (tm) Systems are designed to remove dissolved organics and solvents (chlorinated hydrocarbons) such as PCE, TCE, and DCE from contaminated groundwater. The micro-fine bubbles produced by the microporous diffusers contain oxygen and ozone which oxidize the chlorinated hydrocarbons to harmless gases and weak acids. High initial concentrations of these dissolved organics can, under some specific-circumstances, reduce to levels of 1 ppb or less in periods of a few weeks.

The present invention employs a plurality of configurations with a compressor rated for continuous use, an ozone generator, a second microporous diffuser below a first microporous diffuser in each well, and larger diameter gas tubing.

Normal operation for the systems includes carrying out, in series for each well, the following functions on a timed basis: pumping air & ozone through Spargepoint diffusers into the soil formation, pumping aerated/ozonated water in the well into the soils and recovering treated water above. Treatment is followed by a programmable period of no

external treatment and multiple wells are sequenced in turn. Agitation with pumped water disturbs the usually inverted cone-shaped path of bubbles through the soils and disperses them much more widely. This increases contact and greatly improves efficiency and speed of remediation. Vapor capture is not normally necessary.

Series 3500 and 3600 systems include a control Module (Box), one to three well assemblies depending on specific model selected, a 1-00 ft submersible pump power-gas line for each well, a flow meter (to check spargepoint flow rates). Model Series 3500 & 3600 Control Modules have been successfully deployed outdoors in benign and moderate environments for prolonged periods of time. The Control Module is firmly mounted vertically on 4x4 posts or a building wall near the wells.

The actual placement depths, separations, number/size of wells and overall remediation system geometry are highly variable. Differences in specific pollutant, spill, soil, groundwater and climate characteristics can greatly influence the design and geometry of the overall remediation system. Monitoring wells are usually also needed. In short, specific circumstances and conditions are often critical, however, a typical overall system is shown in FIG. 2.

Table 1 provides the basic specification for the Series 3500 & 3600 systems. The drawing shows a single well system Series 3600 ( M-3601). The Series 3500 does not have the lower Spargepoint Multiple well models (3502, 3503, 3602 & 3603), but just replicates the well units using a single Control Module. FIG. 2 shows a piping schematic and FIG. 3 an electrical schematic for a 3 well system (Model 3503 or 3603). Current production 3500 and 3600 Series models have an internal Ground Fault Interruptor and surge buffers incorporated into various electrical components. FIG. 4 shows an internal layout of the Control Module box for a three well system (M-3503 or M-3603). FIGS. 5A and 5B show the geometry of the bottom panel on the Control Module identifying the external connections and ports for three well units (M-3503 & 3603).

The unique use of Microfine Bubbles for simultaneous extraction/decomposition.

The use of microporous Spargepoint diffusers to create fine bubbles, which easily penetrate sandy formations to allow fluid flow, has unexpected benefits when used with multiple gas systems. Microfine bubbles accelerate the transfer rate of PCE from aqueous to gaseous state. The bubble rise transfers the PCE to the vadose zone. The ten-fold difference in surface-to-volume ratio of Spargepoint diffuser microbubbles compared to bubbles from well screens results in a four-fold improvement in transfer rates. To block the gaseous state from reverting to surface dissolved state in the vadose (unsaturated) zone, a microprocessor system shuttles an oxidizing gas through the vadose zone to chemically degrade the transported PCE.

#### Gaseous Exchange

If gaseous exchange is proportional to available surface area, with partial pressures and mixtures of volatile gases being held constant, a halving of the radius of bubbles would quadruple (i.e. 4x) the exchange rate. If, in the best case, a standard well screen creates air bubbles the size of a medium sand porosity, a microporous diffuser of 20 micron size creates a bubble one tenth ( $\frac{1}{10}$ ) the diameter and then times the volume/surface ratio (see Table 1).



TABLE 1

Diameter (microns)	Surface Area 4 nr <sup>2</sup>	Volume (4/3 r <sup>3</sup> )	Surface Area/Volume
200	124600	4186666	.03
20	1256	4186	.3

Theoretically, the microporous bubbles exhibit an exchange rate of ten times the rate of a comparable bubble from a standard ten slot well screen.

#### Partitioning Enhancement

Soil Vapor concentrations are related to two governing systems: water phase and (non-aqueous) product phase. Henry's and Raoult's Laws (DiGiulio, 1990) are commonly used to understand equilibrium-vapor concentrations governing volatilization from liquids. When soils are moist, the relative volatility is dependent upon Henry's Law. Under normal conditions (free from product) where volatile organic carbons (VOC's) are relatively low, an equilibrium of soil, water, and air is assumed to exist. The compound, tetrachloroethane (PCE), has a high exchange coefficient with a high vapor pressure (atm) and low aqueous solubility ( $\mu\text{mole/l}$ ). By enhancing the exchange capacity at least ten fold, the rate of removal should be accelerated substantially.

Ozone is an effective oxidant used for the breakdown of organic compounds in water treatment. The major problem in effectiveness is a short lifetime. If ozone is mixed with sewage-containing water above-ground, the half-life is normally minutes. However, if maintained in the gaseous form, the half-life of ozone can be extended to a half hour. Using the microbubbles as extracting agents, pulling chlorinated solvents out of the dissolved state into the gaseous form as they enter the bubbles of ozone. The small bubbles' high surface to volume ratio accelerates a) the exchange area and b) the consumption of HVOC within the bubble maximizes the ( $C_s - C$ ) term. In reality the rate-limiting process is the area-specific diffusion (dominated by Henry's Constant), while the decomposition reaction occurs rapidly (assuming sufficient ozone). Ozone reacts quickly and quantitatively with PCE to yield breakdown products of hydrochloric acid, carbon dioxide, and water.

To offset the short life span, the ozone is injected with microporous diffusers, enhancing the selectiveness of action of the ozone. By encapsulating the ozone in fine bubbles, the bubbles preferentially extract volatile compounds like PCE from the mixtures of soluble organic compounds they encountered. The ozone destruction of organic compounds would then target volatile organics selectively pulled into the fine air bubbles. Even in a groundwater mixture of high organic content like diluted sewage, PCE removal could be rapid.

The unique combination of microbubble extraction and ozone degradation can be generalized to predict the volatile organic compounds amenable to rapid removal. The efficiency of extraction is directly proportional to Henry's Constant which serves as a diffusion coefficient for gaseous exchange ( $K_g$ ).

In wastewater treatment the two-film theory of gas transfer (Metcalf and Eddy, Inc, 1991) states the rate of transfer between gas and liquid phases is generally proportional to the surface area of contact and the difference between the existing concentration and the equilibrium concentration of the gas in solution. Simply stated, if we increase the surface to volume ration of contact, we increase the rate of exchange. If we consume the gas (VOC) entering the bubble (or micropore space bounded by a liquid film), the difference

is maintained at a higher entry rate than if the VOC is allowed to reach saturation equilibrium. In our case, of the HVOC, PCE, the consumptive gas/gas reaction of PCE to by products of HCl, CO<sub>2</sub>, and H<sub>2</sub>O accomplishes this.

The normal equation for the two-film theory of gas transfer is stated: (Metcalf and Eddy, 1991)

$$Vm = KgA(C_s - C)$$

where:

Vm=rate of mass transfer

Kg=coefficient of diffusion for gas

A=area through which gas is diffusing

C<sub>s</sub>=saturation concentration of gas in solution

C=concentration of gas in solution the restatement of the equation to consider the inward transfer of phase change from dissolved HVOC to gaseous HVOC in the inside of the bubble would be:

C<sub>s</sub>=saturation concentration of gas phase in bubble

C=initial concentration of gas phase in bubble volume

Table 2 gives the Henry's Constants (H<sub>c</sub>) for a selected number of organic compounds and the second rate constants (R<sub>c</sub>) for the ozone radical rate of reaction. The third column presents the product of both (RRC). As a ranking of effectiveness. In actual practice the diffusion is rate-limiting, resulting in the most effective removal with PCE (tetrachloroethylene).

TABLE 2

REMOVAL RATE COEFFICIENTS YUK THE MICROBUBBLE/OZONE PROCESS - C-SPARGE

Organic Compound	Ozone K <sub>2</sub> Second order Rate Constant <sup>b</sup> (M <sup>-1</sup> SEC <sup>-1</sup> )	K <sub>1</sub> Henry's Constant <sup>b</sup>	Rate Removal Coefficient
Benzene	2	5.59 × 10 <sup>-3</sup>	.0110
Toluene	14	6.37 × 10 <sup>-3</sup>	.0890
Chlorobenzene	0.75	3.72 × 10 <sup>-3</sup>	.0028
Trichloroethylene	17	9.10 × 10 <sup>-3</sup>	.1540
Tetrachloroethylene	0.1	2.59 × 10 <sup>-2</sup>	.026
Ethanol	.02	4.48 × 10 <sup>-5</sup>	.0000008

$$R_c \cdot H_c = RRC$$

<sup>a</sup>From Hoigne and Bader, 1983

<sup>b</sup>From EPA 540/1-86/060, superfund public Health Evaluation Manual

#### Elimination of the Need for Vapor Extraction

The need for vapor control exists when vapors of VOC's partitioned from dissolved form into the microbubbles, reach the unsaturated zone, releasing vapors. Without reaction with a decomposing gas, such as ozone, a large mass can be transmitted in a short time, creating potential health problems near residential basement areas.

The combined extraction/decomposition process has the capacity to eliminate the need for vapor capture. If the decomposition rate with ozone exceeds the vertical time-of-travel, vapors will not be produced or their concentration will be so low as to not require capture. By controlling the size of microbubbles and matching them to suitable slow rise times, the need for vapor control is eliminated.

The rise time of bubbles of different sizes was computed for water, giving the upwards gravitational velocity. The upwards velocity provides the positive pressure to push the bubbles through the porous media, following Darcy's equation. By timing the rise rate in the field; the rise time, proportional to upwards pressure, can be calculated. The bubble size is very important. Once a bubble exceeds the pore cavity size, it is significantly retarded or trapped.

Pulsing of the water phase provides a necessary boost to assure steady upwards migration and reducing coalesion.

BUBBLE DIAMETER	UPWARD VELOCITY IN WATER	TIME (MINUTES) FOR UPWARDS MIGRATION (3 METERS) (Coarse Sand and Gravel)
10 mm	.25 m/s	19 min
2 mm	.16 m/s	30 min
.2 mm	.018 m/s	240 min

#### Elimination Rate of PCE Relative to Ozone Content

The reaction of ozone with tetrachloroethane (PCE) will produce degradation products of hydrochloric acid, carbon dioxide, and water. By adjusting the ozone concentration to match the dissolved PCE level, the PCE can be removed rapidly without excess ozone release to the air or release of PCE vapor into the unsaturated zone.

Accordingly, the object and purpose of the present invention is to provide microporous diffusers for removal of contaminants from soil and associated subsurface ground water aquifer, without requiring applying a vacuum for extraction biodegradation by-products.

Another object is to provide multi-gas systems to be used in combination with the microporous diffusers to promote an efficient removal of poorly biodegradable organics, particularly dissolved chlorinated solvents, without vacuum extraction.

A further object is to provide that remediation occurs by destroying organic and hydrocarbon material in place without release of contaminating vapors to the atmosphere.

The invention will be described for the purposes of illustration only in connection with certain embodiments; however, it is recognized that those persons skilled in the art may make various changes, modifications, improvements and additions on the illustrated embodiments all without departing from the spirit and scope of the invention.

#### BRIEF DESCRIPTION OF THE DRAWINGS

FIG. 1. is a cross sectional schematic illustration of a soil formation showing the apparatus of the present invention.

FIG. 2. is shows an enlarged piping schematic of the present invention of FIG. 1 showing the unique fine bubble production chamber;

FIG. 3. is an electrical schematic for a 3 well system (Model 3503 or 3603) of the present invention of FIG. 1;

FIG. 4. shows an internal layout of the Control Module box for a three well system (M-3503 or M-3603) of the present invention of FIG. 1;

FIG. 5A. shows the geometry of the bottom panel on the Control Module identifying the external connections and ports for three well units (M-3503 & 3603) of the invention of FIG. 1

FIG. 5B. is the left side view of FIG. 5A;

FIG. 6. is a schematic illustration of a soil formation showing the apparatus of the present invention;

FIG. 7. is a perspective view of a Bubbler Sparge Unit for Groundwater Treatment useful in the system of FIG. 1.

FIG. 8. is a front view of FIG. 7; the rear being a mirror image thereof; is the left side; and the right side;

FIG. 9. is a top elevational view of FIG. 7;

FIG. 10. is a bottom elevational view of FIG. 7;

FIG. 11. is a front elevational view of FIG. 7; the broken line showing the sparge bubbler unit in-situ for groundwater treatment.

FIG. 12. is an alternate embodiment of a microporous spargepoint assembly of the invention of FIG. 1.

FIG. 13. is a outline of Table 1.

#### DETAILED DESCRIPTION OF THE PREFERRED EMBODIMENT

The present invention uses sparging apparatus for injection of oxidizing gas in the form of small bubbles into aquifer regions to encourage in situ remediation of subsurface leachate plumes. In particular the present invention employs microporous diffusers injecting multi-gas bubbles into aquifer regions to encourage biodegradation of leachate plumes which contain biodegradable organics, or Criegee decomposition of leachate plumes containing dissolved chlorinated hydrocarbons.

Referring to the FIGS. 1 and 7-13 there is shown a Sparge System 10 of multiple microporous diffusers in combination with an encapsulating multi-gas system. The system 10 includes a master unit 12 and one or more in-well sparging units 14. Each master unit 12 can operate up to a total of three wells simultaneously, and treating an area up to 50 feet wide and 100 feet long. Actual performance depends upon site conditions. Vapor capture is not normally necessary. In the preferred embodiment, as shown in FIG. 1, and FIG. 2 master unit 12 includes the following: a gas generator 16, a gas feed line 15, a compressor 18, a power source 19, a pump control unit 20, a timer 2. The master unit 12 can be firmly mounted on 4x4 posts 40 or building wall 42 near in-well sparging units 14. A heavy-duty power cable 44, may be used to run from the power source to the master unit 12.

Referring to FIGS. 1 and 2, the in-well sparging unit 14 includes of a casing 56, an inlet screen 50 an expandable packer 52, an upper site grout 54, an outlet screen 58, and lower grout 62. Each inwell unit 14 includes a fixed packer 24, at least two microporous diffusers 26 hereinafter diffusers" 26, a water pump 28, ozone line 30, check valve 32, and fittings 34. As is shown in FIGS. 1 and 2 the diffuser 26 employs a microporous diffuser in place of standard slotted well screen to improve dispersion of bubbles 60 through soil shown at 84 and improve rate of gaseous exchange. A normal 10-slot PVC well screen contains roughly twelve percent (12%) open area. Under pressure most air exits the top slits and radiates outward in a starlike fracture pattern, evidencing fracturing of the formation.

Referring to FIG. 2 there is shown a fine bubble production chamber 46 positioned in the well casing 56 between the upper well screen 50 positioned immediately below fixed packer 24 of a removable closure plug and the lower plug 48 of the fine bubble production chamber 46 containing bubbles 60 including upper microporous diffuser 26 positioned above lower well screen 58 including pump 28 and check valve 32.

Referring to FIG. 4 there is shown the internal layout of the control module box 12 including an AC/DC power converter 71, and ozone generator 72, well gas relays 73 (three wells shown) a compressor 74, a master relay 75, a main fuse 76. There is also shown a programmable timer controller 77, a power strip 78, a gas regulator and pressure gauge 79, together with a solenoid manifold 80, a ground fall interrupter 81 and a cooling fan 82.

Spargepoint diffusers include several unique configurations as follows;

- Direct substitute for well screen, 30% porosity 5-50 micron channel size resistance to flow only 1 to 3 PSI, can take high volume flow, needs selective annular pack (sized to formation). High density polyethylene or polypropylene is light weight, rugged, inexpensive.

- b. Diffuser on end of narrow diameter pipe riser KVA 14-291. This reduces the residence time in the riser volume.
- c. Shielded microporous diffuser which is injected with a hand-held or hydraulic vibratory hammer. The microporous material is molded around an internal metal (copper) perforated tubing and attached to an anchor which pulls the spargepoint out when the protective insertion shaft is retracted. Unit is connected to surface with  $\frac{3}{16}$  or  $\frac{1}{4}$  inch polypropylene tubing with a compression fitting.
- d. Thin spargepoint with molded tubing can be inserted down narrow shaft for use with push or vibratory tools with detachable points. The shaft is pushed to the depth desired, then the spargepoint inserted, the shaft is pulled upwards, pulling off the detachable drive point and exposing the spargepoint.
- e. Microporous diffuser/pump combination placed within a well screen in such a manner that bubble production and pumping is sequenced with a delay to allow separation of large bubbles from the desired fine "champagne" bubbles. The pressure from the pump is allowed to offset the formation back pressure to allow injection of the remaining fine bubbles into the formation.

In the present invention the improvement comprises several new equipment designs associated with the spargepoint diffusers. One design is a diffuser comprised of HDPE porous material with well fittings and pass-through design which allows individual pressure and flow control.

Secondarily, the push-probe points have been developed for use with pneumatic tools, instead of drilling auger insertion on controls, the right-angle mirror wellhead assembly needs better protection.

Improvements on C-sparger/microporous spargepoint diffuser. One of the major pass-through spargepoints problems in horizontal sparging is even distribution of air bubbles. If inflow is attached to the end of a screen, the pressure drops continuously as air is released from the screen. The resulting distribution of flow causes most bubbles to be produced where the connection occurs with flow alternating outwards. The end of the screen products little or no bubbles.

To allow even distribution of bubbles, either individual spargepoints are bundled (spagetti tube approach) or the spargepoint are constructed in a unique way which allows interval tubing connections with flow and pressure control for each spargepoint region with the proposed arrangement, connecting tubing, to spargepoints passes through the spargepoint internally without interfering with function of producing small bubbles on a smooth external surface (2) the tubing penetration reducing the internal gas volume of the spargepoint, thereby reducing residence time for oxidative gases (important since ozone has only a certain lifetime before decomposition), and allows 3 to 4 spargepoints to be operated simultaneously with equal flow and pressure. Each spargepoint can also be programmed to pulse on a timed sequencer, saving electrical costs and allowing certain unique vertical and horizontal bubble patterns. Spargepoint diffusers can be fitted with F480 Thread with internal bypass and compression fittings:

- 
- Advantages (2) fits standars well screen;  
(3) Allows individual flow/pressure control;

-continued

- 
- (4) Reduces residence time;  
(5) Allows casing/sparge instead of continuous bubbler.
- 

Use of Injectable Points configured as Moulded: 18 Inch 0.40 inch HDPE moulded into  $\frac{1}{4}$  inch pp tubing or HDPE tubing allows smooth tube to be inserted into push probe with detachable point. Use of Bullet prepacked Spargepoint diffusers: with KVA "hefty system" prepacked sand cylinder and bentonite cylinder placed over tubing and porous point. Also use of a porous point reinforced with inner metal tube (perforated) to allow strength throughout tubing resists disintegration of plastic during insertion.

Use of Pressure/flow headers: Rodometer/mirror: Mirror assembly for flush-mounted rotometer (flowmeter), allows reading from vertical down and controls flow off lateral lines to adjust to back pressure from varying types of formations (silt, sand, gravel) below.

It is well recognized that the effectiveness of treatment is dependent upon uniformity of dispersion of the gas as it travels through the formation. A porous structure with appropriate packing matches the condition of the pores of the soil with thirty percent (30%) pore distribution. The dispersion of bubbles as a fluid can be checked with Darcy's equation.

The use of microporous materials in the "Spargepoint<sup>TM</sup>" to inject gases into groundwater saturated formations has special advantages for the following reasons:

1. Matching permeability and channel size;
2. Matching porosity;
3. Enhancing fluidity, which can be determined in-situ.

The most effective range of pore space for the diffuser material selected depends upon the nature of the unconsolidated formation to be injected into, but the following serves as a general guide:

1. Porosity of porous material: thirty percent (30%);
2. Pore space: 5-200 microns;
  - a. 5-20 very fine silty sand;
  - b. 20-50 medium sand;
  - c. 50-200 coarse sand and gravel.

The surrounding sand pack placed between the spargepoint 26 and natural material to fill the zone of drilling excavation should also be compatible in channel size to reduce coalescing of the produced bubbles.

The permeability range for fluid injection function without fracturing would follow:

1.  $10^{-2}$  to  $10^{-6}$  cm/sec, corresponding to 2 to 2000 Darcy's; or
2.  $20^{-2}$  to  $10^{-6}$  cm/sec; or
3. 100 to 0.01 ft/day hydraulic conductivity.

Permeability is the measure of the ease of movement of a gas through the soil. The ability of a porous soil to pass any fluid, including gas, depends upon its internal resistance to flow, dictated largely by the forces of attraction, adhesion, cohesion, and viscosity. Because the ratio of surface area to porosity increases as particle size decreases, permeability is often related to particle size see Table 2.

What is claimed is:

1. A method for decomposing contaminants in a soil formation containing a subsurface groundwater aquifer comprises:

introducing ambient air including ozone at concentrations to effect removal of contaminants as fine bubbles into the soil formation and under conditions to cause a Criegee-like reaction of the ozone with contaminants brought into the bubbles.

## 11

2. The method of claim 1 wherein the fine bubbles are sized in accordance with a porosity characteristic of the soil formation.

3. The method of claim 1 wherein introducing further comprises:

providing a plurality of injection wells and introducing the ambient air and ozone as fine bubbles through the injection wells.

4. The method of claim 1 wherein introducing further comprises:

mixing the ambient air with the ozone.

5. The method of claim 1 wherein introducing further comprises:

mixing the ambient air with the ozone; and

delivering the ambient air and ozone through a plurality of micro-porous diffusers to produce the fine bubbles of ambient air and ozone.

6. The method of claim 5 wherein the micro-porous diffusers have a pore size between about 5 to 200 microns to provide the fine bubbles.

7. The method of claim 5 wherein the micro-porous diffusers have a pore size between about 50 to 200 microns to provide the fine bubbles.

8. The method of claim 5 wherein the micro-porous diffusers have a pore size between about 20 to 50 microns to provide the fine bubbles.

9. The method of claim 5 wherein the micro-porous diffusers have a pore size between about 5 to 20 microns to provide the fine bubbles.

10. The method of claim 5 wherein the micro-porous diffusers have a pore size selected to match a porosity characteristic of the surrounding soil formation.

11. The method of claim 10 wherein the micro-porous diffusers have a pore size selected to match a porosity characteristic and a permeability characteristic of the surrounding soil formation.

12. The method of claim 1 wherein contaminants in the soil formation are decomposed by ozone interaction in the bubbles with double bonded carbon atoms of the contaminants.

## 12

13. The method of claim 1 wherein the fine bubbles have an initial bubble size between about 5 to 200 microns.

14. The method of claim 1 wherein the fine bubbles have an initial bubble size between 50 to 200 microns.

15. The method of claim 1 wherein the fine bubbles have an initial bubble size between 20 to 50 microns.

16. The method of claim 1 wherein the fine bubbles have an initial bubble size between 5 to 20 microns.

17. The method of claim 1 further comprising:

providing a plurality of injection wells and introducing the ambient air and ozone as fine bubbles through the injection wells by using a corresponding micro-porous diffuser for each one of the plurality of injection wells; surrounding the micro-porous diffusers with a sand pack disposed between the micro-porous diffusers and the surrounding soil formation.

18. The method of claim 1 wherein the fine bubbles increase the lifetime of ozone in the soil formation.

19. The method of claim 1 wherein removal of contaminants can occur without a vapor extraction.

20. The method of claim 1 further comprising pulsing a water phase to provide steady upward migration of the fine bubbles through the soil formation.

21. The method of claim 1 wherein the soil formation contains chlorinated hydrocarbons.

22. The method of claim 1 wherein the soil formation contains chlorinated ethenes.

23. The method of claim 1 wherein the contaminants include chlorinated ethenes including dichloroethene, trichloroethene, and/or tetrachloroethene.

24. The method of claim 1 wherein introducing uses micro-porous diffusers that have a pore size selected to match a permeability characteristic of the surrounding soil formation.

\* \* \* \* \*