



US006079998A

# United States Patent [19]

[11] Patent Number: **6,079,998**

**Kamath**

[45] Date of Patent: **Jun. 27, 2000**

[54] **LOW INSERTION FORCE CONNECTOR WITH GEAR DRIVEN CAMS**

[75] Inventor: **Shashidhar M. Kamath**, Belleville, Mich.

[73] Assignee: **Yazaki North America, Inc.**, Canton, Mich.

[21] Appl. No.: **09/221,812**

[22] Filed: **Dec. 29, 1998**

[51] Int. Cl.<sup>7</sup> ..... **H01R 13/15**

[52] U.S. Cl. .... **439/259**

[58] Field of Search ..... 439/259, 122, 439/197, 252, 261, 263, 71, 75, 74, 264, 268, 912

*Primary Examiner*—Lincoln Donovan  
*Assistant Examiner*—Chandrika Prasad  
*Attorney, Agent, or Firm*—Young & Basile, P.C.

[57] **ABSTRACT**

A first connector has a series of movable terminals having bifurcated ends comprising first and second prongs spaced apart from one another and a pair of parallel, rotatable cam members disposed on either side of the first prongs to sandwiching them therebetween. The cam members are elliptical in cross section and are connected with one another by intermeshing gears to rotate in unison. A second connector has a series of fixed terminals and a pair of actuation arms extending parallel with the terminals and having toothed ends. As the first and second connectors are moved into engagement with one another, the fixed terminals are inserted between the first and second prongs and the toothed ends engage the gears, rotating the cam members so they deflect the movable terminals to bring the second prongs into contact with the fixed terminals. Contact between the two sets of terminals is delayed until the last few millimeters of travel of the first and second connectors as they are mated, thus substantially reducing the frictional resistance resulting from contact between the terminals.

[56] **References Cited**

**U.S. PATENT DOCUMENTS**

3,848,221	11/1974	Lee, Jr. .	
4,176,900	12/1979	Hines et al. .	
4,370,011	1/1983	Suzuki et al. ....	439/264
4,778,395	10/1988	Narita .....	439/71
5,496,186	3/1996	Dobbelaere et al. ....	439/157
5,721,669	2/1998	Becker et al. ....	361/685
5,961,344	10/1999	Rosales et al. ....	439/495

**12 Claims, 3 Drawing Sheets**

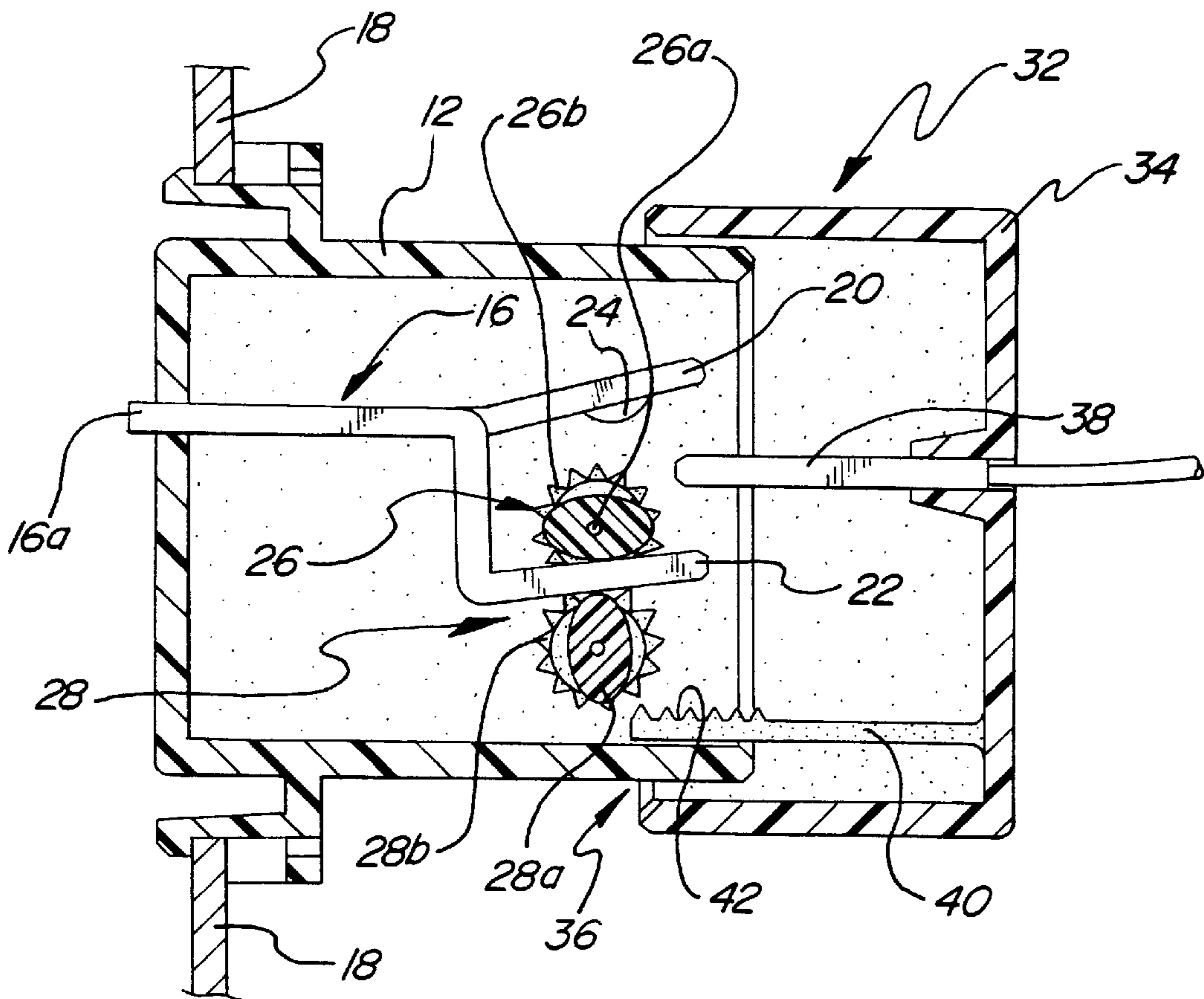

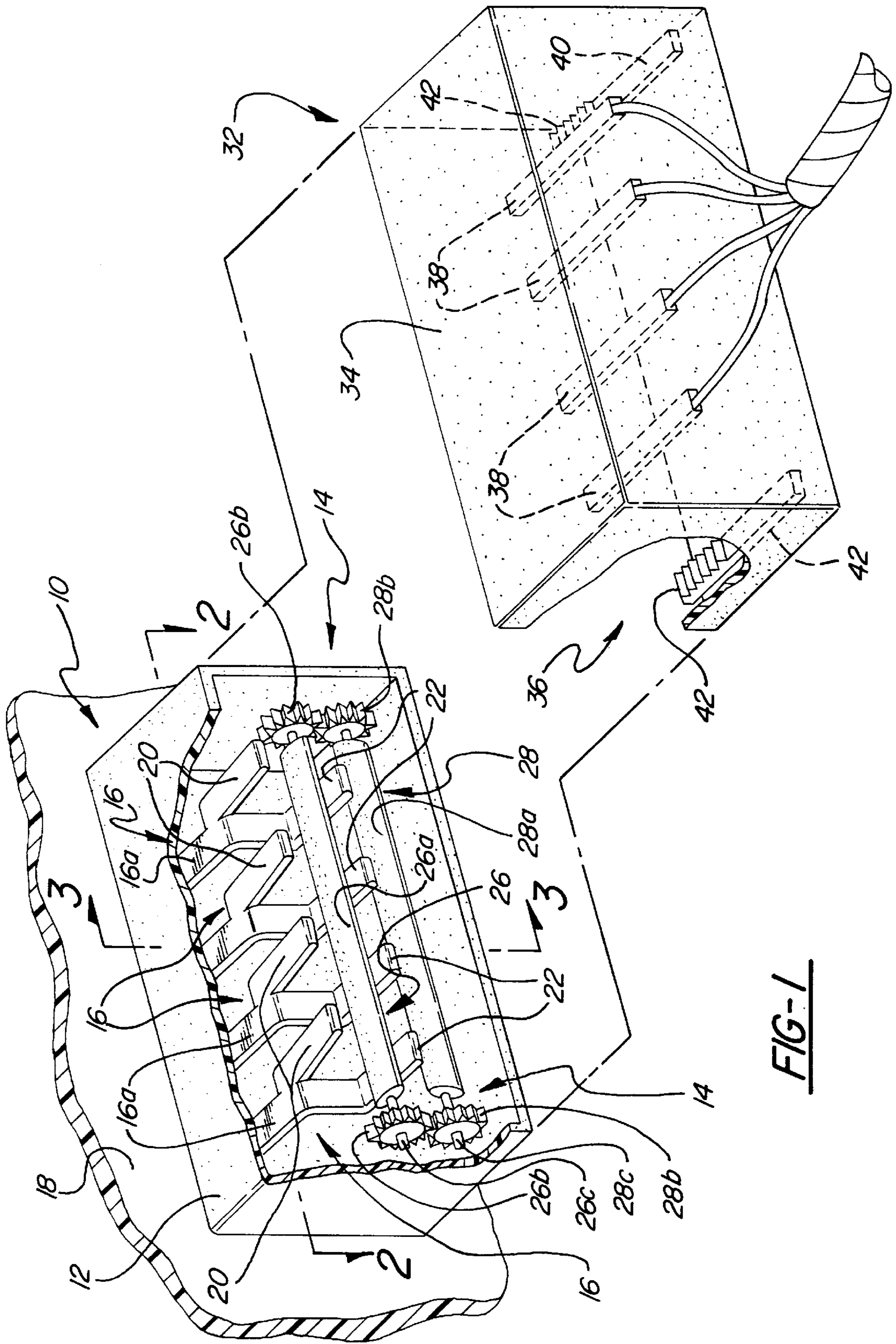

FIG-1

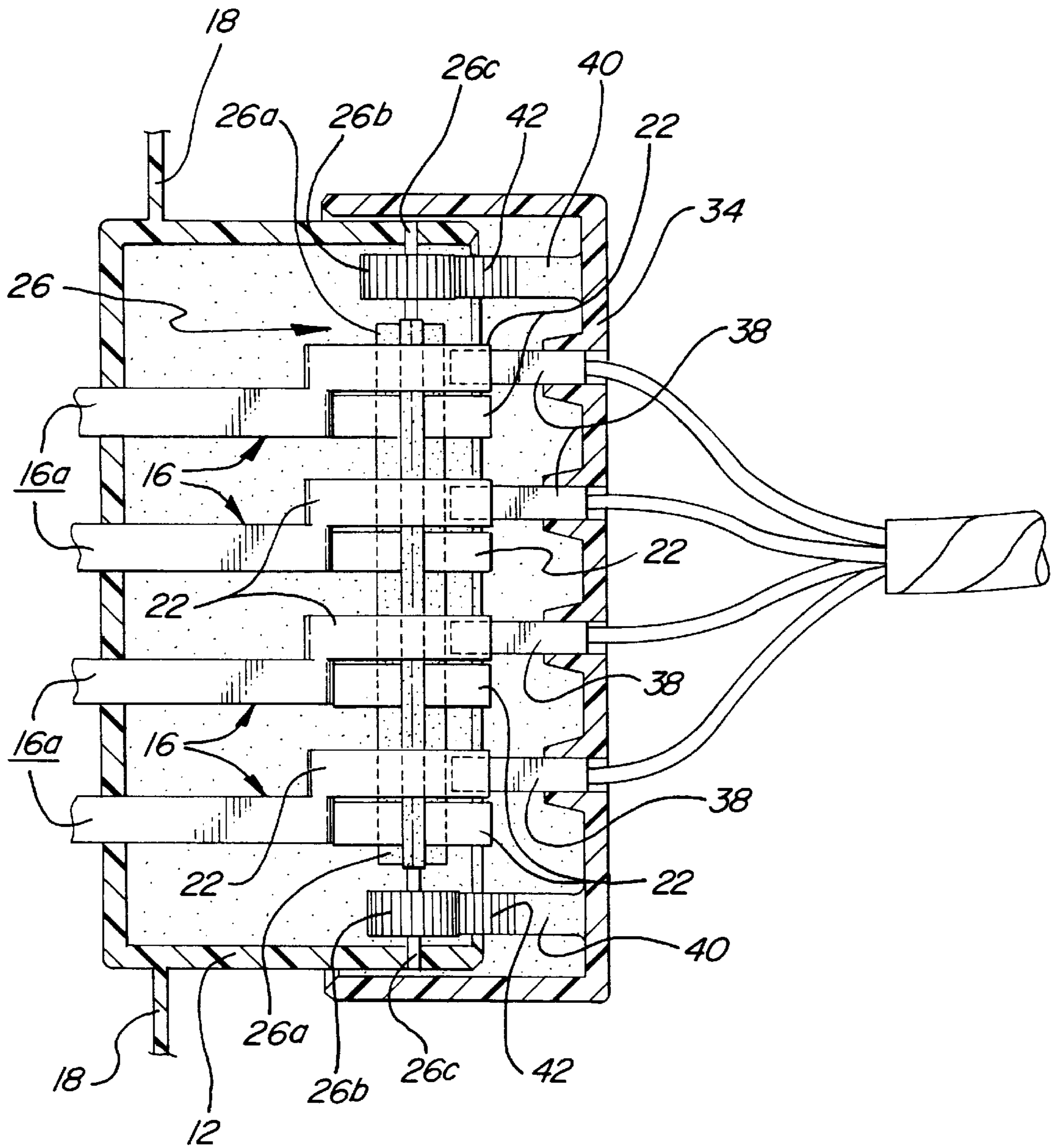
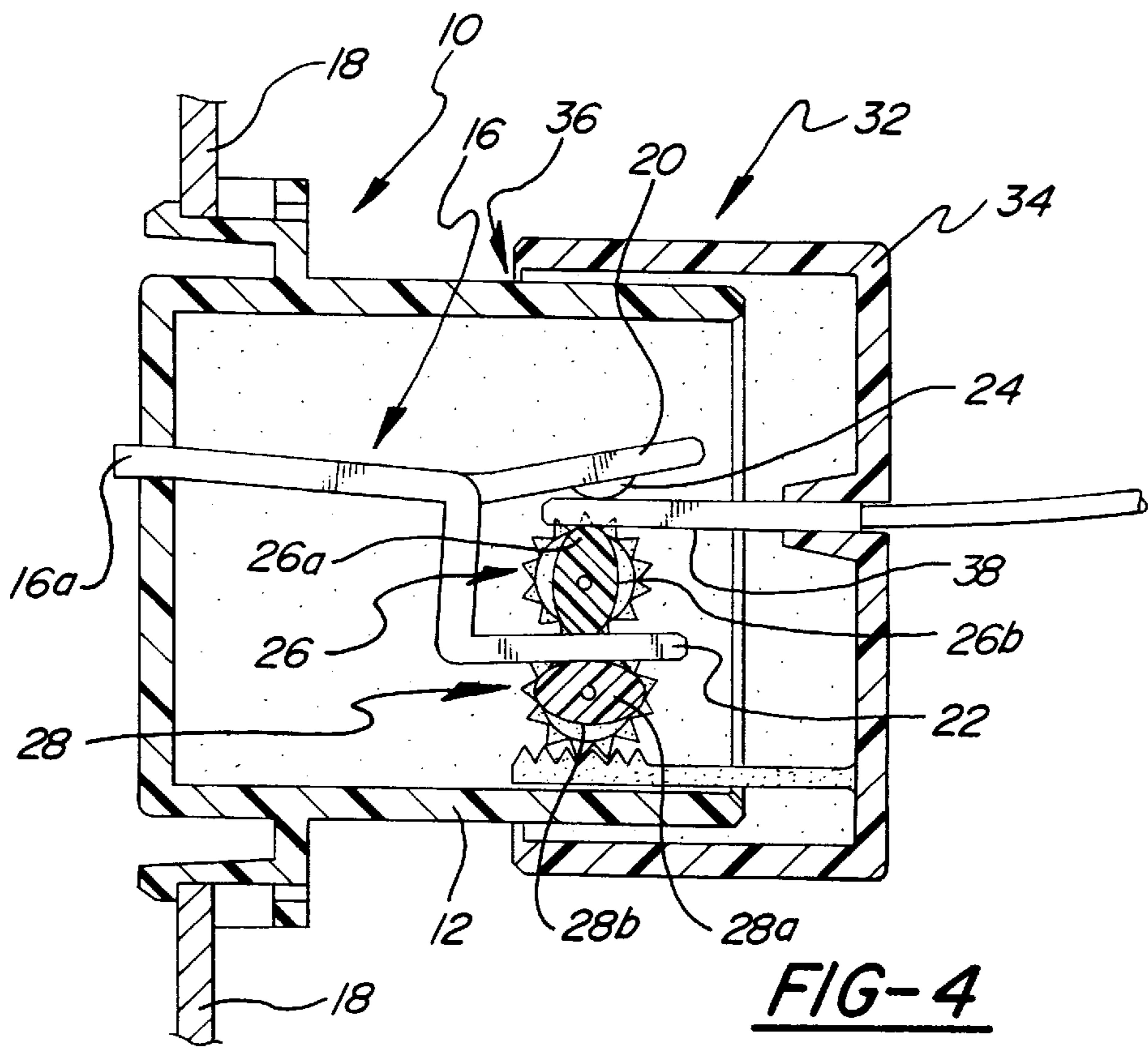
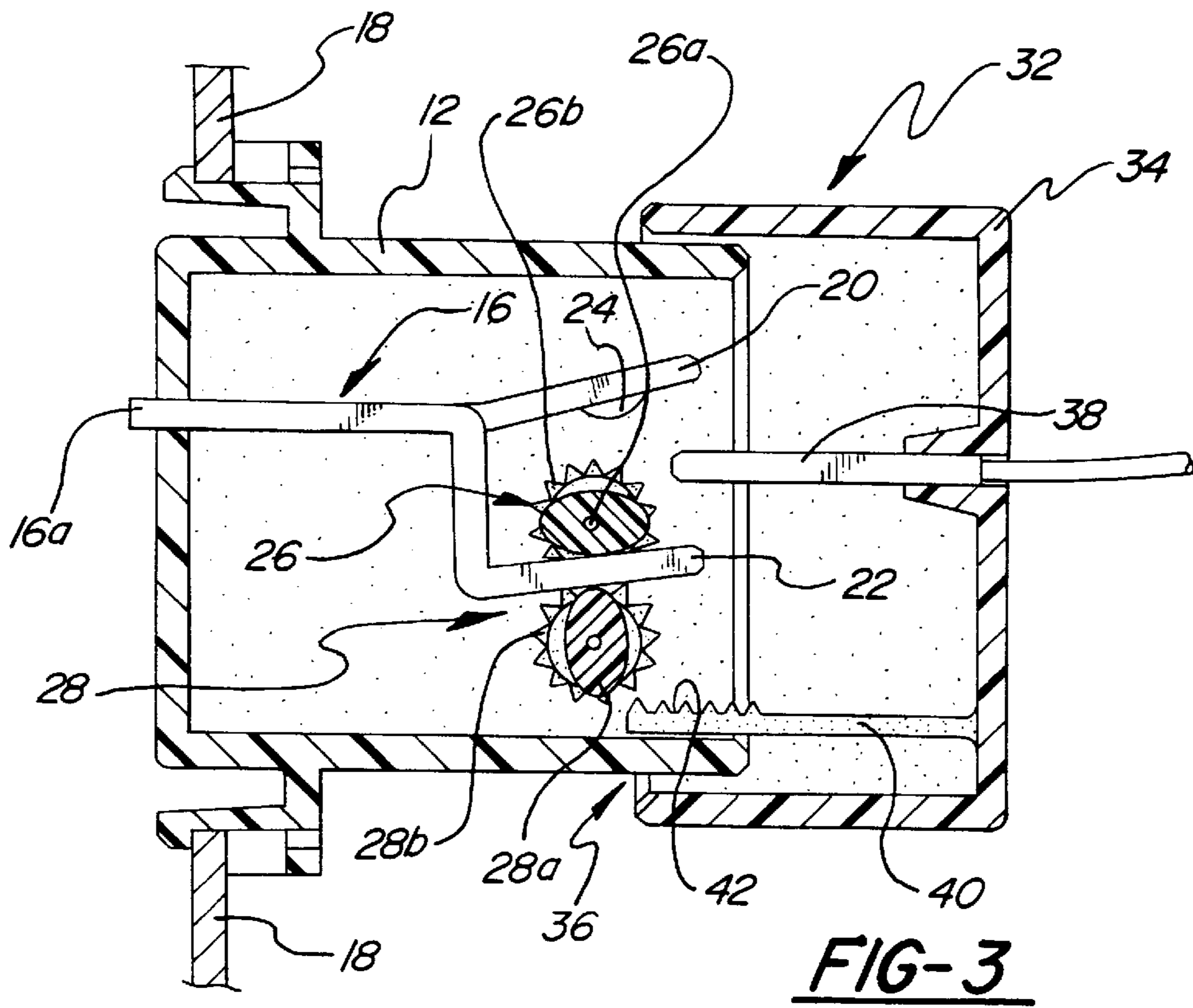

FIG-2





## LOW INSERTION FORCE CONNECTOR WITH GEAR DRIVEN CAMS

### FIELD OF THE INVENTION

This invention relates in general to multi-pin electrical connectors and more specifically to an electrical connector assembly in which the amount of force required to insert two mating connectors into engagement with one another is greatly reduced.

### BACKGROUND OF THE INVENTION

As the number and complexity of electrical circuits in modern automobiles has increased, electrical connectors having large numbers of terminals have become more common. It is not unusual for a single electrical connector to contain 32 individual terminals. In conventional electrical connectors, the movement of a pair of connectors into engagement with one another causes male and female terminals housed in the respective connectors to slide into contact with one another. A certain degree of normal force between the terminal contact surfaces is required for good electrical conductivity between the terminals, resulting in a relatively high level of frictional resistance to insertion of the mating terminals into engagement with one another. The greater the number of terminals in a connector, the greater the total force required to overcome this resistance to engagement of the connectors. Connectors having a large number of terminals may be so difficult to mate that to do so by hand, as is often required in a production line environment, is quite difficult.

Most electrical connectors include some type of latching mechanism for holding the two connectors in mated engagement with one another. This generally takes the form of a spring latch arrangement which further adds to the amount of resistance to inserting the two connectors into engagement with one another.

This high insertion force problem has been dealt with in the past by connector assemblies which employ a two-step connector mating operation. In such an assembly, the first step involves moving the connector bodies which house the terminals into mating engagement with one another, but the male and female terminals are positioned within the bodies such that the terminals themselves do not yet make contact with one another. In the second step, a button, lever, or switch is actuated to move one or the other, or both, of the sets of terminals relative to their connectors to bring the terminals into physical and electrical contact. This procedure has the obvious drawback of requiring two separate actions on the part of the person or machine making the connection, thus making the assembly process more complicated and time consuming.

It is known to provide mating connectors with cam-type means which deflect a first set of terminals into contact with mating terminals as the two connectors are inserted into engagement with one another. See, for example, U.S. Pat. No. 4,176,900.

It would be desirable to provide an electrical connector assembly in which first and second mating connectors may be inserted into engagement with one another without a large amount of insertion force and without requiring a secondary mating operation.

### SUMMARY OF THE INVENTION

It is an object of this invention to provide a low insertion force connector assembly which can be used to advantage with connectors accommodating large numbers of terminals.

Another object of this invention is to reduce or eliminate the frictional forces between male and female terminals during mating of their respective electrical connectors.

A further object of this invention is to provide a simple, inexpensive connector mechanism for bringing terminals into electrical contact with one another without a secondary mating operation.

The invention connector assembly includes first and second connectors having respective first and second sets of electrical terminals disposed therein. At least one cam member is rotatably mounted to the first connector adjacent the first terminals such that as it rotates it contacts the terminals and urges them sideways to a deflected position. As the connectors are moved into mating engagement with one another, the second terminals are inserted into overlapping relationships with respective first terminals, and an actuation member disposed on the second connector engages the cam member and causes it to rotate such that the first terminals are urged sideways into contact with the second terminals. As the first and second connectors are withdrawn from mating engagement, the actuation member rotates the cam member in the opposite direction such that the first terminals move away from the second terminals. In this fashion, contact between the first and second terminals is delayed until the last few millimeters of travel of the first and second connectors as they are mated, thus substantially reducing the frictional resistance resulting from contact between the terminals.

According to another feature of the invention, the first terminals have bifurcated ends comprising first and second prongs spaced apart from one another, and a pair of cam members are disposed on either side of the first prong, sandwiching it therebetween. The cam members are connected with one another to rotate in unison, and as they do so they deflect the terminals so that the second prongs make contact with the respective second terminals.

In a preferred embodiment of the invention, the first and second cam members have gears disposed at either end which mesh with one another to ensure that the cam members rotate in unison, and actuation members are disposed at opposite sides of the second connector and comprise racks which engage respective gears at opposite ends of the cam members.

### BRIEF DESCRIPTION OF THE DRAWINGS

FIG. 1 is a cut-away perspective view of first and second connectors according to the present invention;

FIG. 2 is a cross-sectional view taken along line 2—2 of FIG. 1, with the first and second connectors in a mated condition;

FIG. 3 is a cross-sectional view taken along line 3—3 of FIG. 1 with the connectors in a pre-mated position; and

FIG. 4 is a cross-sectional side view similar to that of FIG. 3, but with the connectors in a mated condition.

### DETAILED DESCRIPTION OF THE PREFERRED EMBODIMENT

Referring now to FIGS. 1—4, a first connector **10** comprises a plastic housing **12** of substantially rectangular exterior configuration and having an open mating end **14**. A plurality of metal terminals **16** are disposed within the first connector **10** in a straight line across the width thereof. The terminals **16** have bifurcated forward ends oriented toward the mating end **14** of the connector and stems **16a** which extend through a rear wall of the connector where they make



electrical connection with wires or other conventional electrically conductive means (not shown). The first connector **10** is shown mounted on a panel **18**, but the present invention may be practiced with other types of connectors such as those which terminate wire harnesses.

The bifurcated end of each terminal **16** comprises an upper prong **20** and a lower prong **22**. The terminals **16** may be economically fabricated by stamping a strip of sheet metal to have a Z-shaped bend which forms the lower prong **22**, while the upper prong **20** extends generally straight out from the stem **16a** and is attached thereto at a common edge. As a result of this forming method, the prongs **20,22** are offset horizontally from one another by a small amount. As best seen in FIGS. **3** and **4**, the upper prong **20** may extend upwardly at an angle from the terminal stem **16a** as necessary to achieve the correct spacing between the prongs. The upper prongs **20** have contact bumps **24** protruding from the lower surfaces thereof adjacent their free ends.

Upper and lower deflecting members **26,28** respectively extend transversely across the width of the first connector **10** adjacent the mating end **14**. Each deflecting member **26,28** comprises a cam member **26a,28a** that is generally elliptical or oblong in cross-section, gears **26b,28b** fixed to either end of the center section, and mounting pins **26c,28c** projecting from the central axes of the gears. The mounting pins **26c,28c** fit into holes in the side walls of the first connector **10** so that the cam members **26,28** are rotatable about parallel axes extending transversely between the side walls. The upper and lower deflecting members **26,28** are spaced apart from one another to pass immediately above and below the lower prongs **22**, and the gears **26b,28b** mesh with one another so that the cam members must rotate in unison. As best seen in FIG. **3**, the gears **26b,28b** mesh such that the elliptical cam member **26a,28a** are 90° out of phase with one another at all times.

A second connector **32** comprises a plastic housing **34** of substantially rectangular exterior configuration and having an open mating end **36**. A plurality of metal terminals **38** are disposed within the second connector **32** in a straight line across the width thereof and are equal in number and spacing to the terminals **16** of the first connector **10**. A pair of drive arms **40** are disposed inside the housing **34** adjacent the lower corners thereof and extend parallel to the terminals **38**. The upper surface of each arm **40** adjacent its free ends comprises a rack **42** made up of a plurality of parallel teeth. The drive arms **40** are preferably molded integrally with the housing **34**.

Prior to mating of the first and second connectors **10,32**, the major axis of the lower deflecting member **28** is oriented vertically and the major axis of the upper deflecting member **26** is oriented horizontally, as depicted in FIGS. **1** and **3**. In this configuration, the deflecting members **26,28** are spaced from one another by a distance such that the lower prongs **22** just fit between them and the terminals **16** are in an undeflected condition.

As the first and second connectors **10,32** are mated with one another, the second connector housing **34** fits over and around the first connector housing **12** and the second connector terminals **38** extend between the upper and lower prongs **20,22** of the respective first connector terminals **16**. The drive arms **40** slide into the mating end **14** of the first connector **10** and pass immediately below the lower deflecting member gears **28b** such that the racks **42** engage the lower deflecting member gears and cause them to rotate. As the connectors **10,32** are moved to the fully mated condition shown in FIG. **4**, the upper and lower deflecting members

**26,28** rotate through 90° such that the major axis of the lower deflecting member **28** is oriented horizontally and the major axis of the upper deflecting member **26** is oriented vertically, thus urging the lower prongs **22** downwardly. This causes the terminals **16** to bend or deflect downwardly such that the upper prongs **20** come into contact with the second connector terminals **38**.

When the deflecting members **26,28** are rotated to this fully mated position, the lower prongs **22** are held securely between the upper and lower deflecting members **26,28** and the second connector terminals **38** are held securely between the upwardly facing edge of the upper deflecting member **26** and the bumps **24** of the upper prongs **20**. Accordingly, both the upper and lower prongs **20,22** are supported by the deflecting members **26,28** to ensure proper positioning and resist any movement that may be caused by vibration during use.

When the first and second connectors **10,32** are withdrawn from mated engagement with one another, the racks **42** move relative to the lower deflecting member gears **28b** such that the deflecting members **26,28** rotate back to the configuration shown in FIG. **3**, thus urging the terminals **16** back to their undeflected positions and so breaking contact with the second connector terminals **38**.

As is apparent from the foregoing description, the present invention reduces the amount of insertion force required to mate the two connectors because there is no sliding contact between the mating terminals **16,38** as the connectors are moved into engagement with one another, and therefore there is no frictional force to overcome during the mating procedure. No separate, second actuation step is required to bring the male and female connectors into contact with one another.

While the invention has been described in connection with what is presently considered to be the most practical and preferred embodiment, it is to be understood that the invention is not to be limited to the disclosed embodiments but, on the contrary, is intended to cover various modifications and equivalent arrangements included within the spirit and scope of the appended claims, which scope is to be accorded the broadest interpretation so as to encompass all such modifications and equivalent structures as is permitted under the law.

The invention claimed is:

1. A connector assembly comprising:
  - first connector having a plurality of movable terminals disposed thereon;
  - a second connector having a plurality of fixed terminals, the second connector matingly engagable with the first connector;
  - deflecting member rotatably mounted on the first connector for deflecting the movable terminals; and
  - member disposed on the second connector for engaging and rotating the deflecting member as the first and second connectors are matingly engaged with one another, said rotation of the deflecting means urging the movable terminals into contact with respective fixed terminals.
2. A connector assembly according to claim 1 wherein at least one of the movable terminals has a bifurcated end comprising first and second prongs spaced apart from one another, the first prong for being acted upon by the deflecting member and the second prong for making contact with the respective fixed terminal.
3. A connector assembly according to claim 1 wherein the deflecting member comprises a deflecting member having at



## 5

least one gear and the rotating means comprises a rack engagable with the gear to rotate the deflecting member.

4. A connector assembly according to claim 1 wherein the deflecting member comprises first and second deflecting members sandwiching the movable terminals therebetween, the first and second deflecting members engaged with one another for simultaneous rotation between a first condition wherein the cam members urge the movable terminals toward the fixed terminals in response to insertion of the first and second connectors into mating engagement with one another and a second condition wherein the cam members urge the movable terminals away from the fixed terminals in response to withdrawal of the first and second connectors from said mating engagement.

5. A connector assembly according to claim 4 wherein the first and second cam members each comprise at least one gear, the first and second cam member gears in meshing engagement with one another.

6. A connector assembly according to claim 5 wherein the first and second cam members extend in parallel between first and second sides of the first connector, and each of the cam members have first and second gears disposed at either end thereof adjacent the respective first and second sides of the first connector, the first gears meshingly engaged with one another and the second gears meshingly engaged with one another.

7. A connector assembly according to claim 5 wherein the rotating means comprises a rack engagable with at least one of the gears.

8. A connector assembly according to claim 4 wherein at least one of the movable terminals has a bifurcated end comprising first and second prongs spaced apart from one another, the first cam member disposed between the first prong and the second prong and the second cam member disposed adjacent a side of the first prong opposite the first cam member such that the first and second cam members sandwich the first prong therebetween, and the second prong contacting the fixed terminal when the first and second connectors are in mating engagement.

9. A connector assembly according to claim 1 wherein the deflecting member comprises a cam member extending between first and second sides of the first connector and having an oblong cross section, and the movable terminals are disposed in a line parallel with the cam member.

10. A connector assembly comprising:

a first connector having at least one movable terminal disposed thereon, the movable terminal having a bifurcated end comprising spaced apart first and second prongs;

a second connector matingly engagable with the first connector and having at least one fixed terminal disposed thereon; and

means for contacting the first prong as the first and second connectors are matingly engaged with one another and

## 6

urging the movable terminal such that the second prong contacts the fixed terminal.

11. A connector assembly according to claim 10 wherein the means for contacting the movable terminal prong comprises at least one cam member rotatably mounted on the first connector and at least one actuation member disposed on the second connector, the actuation member engaging the cam member and urging it into contact with the first prong when the first and second connectors are matingly engaged with one another.

12. A connector assembly comprising:

a first connector having opposite first and second side walls and a plurality of movable terminals disposed in a substantially straight line therebetween, each of the movable terminals having a bifurcated end comprising first and second prongs spaced apart from one another;

a second connector having opposite first and second side walls and a plurality of fixed terminals disposed therebetween, the second connector matingly engagable with the first connector to insert the fixed terminals between the prongs of respective movable terminals;

a first cam member rotatably mounted to and extending between the side walls of the first connector and disposed between the first prongs and the second prongs, the first cam member having first and second gears adjacent either end;

a second cam member rotatably mounted to and extending between the side walls of the first connector adjacent a side of the first prongs opposite the second prongs such that the first and second cam members sandwich the first prongs therebetween, the second cam member having first and second gears adjacent either end meshingly engaged with respective first and second gears of the first cam member such that the cam members rotate in unison between a first condition wherein the cam members urge the movable terminals such that the second prongs contact the fixed terminals and a second condition wherein the cam members urge the movable terminals away from the fixed terminals; and

at least one cam actuation member disposed on the second connector and having a rack portion for engagement with at least one of the gears when the first and second connectors are in mating engagement with one another, said engagement between the rack portion and the at least one gear rotating the cam members toward the first condition as the first and second connectors are moved into mating engagement with one another and toward the second condition as the first and second connectors are withdrawn from said mating engagement.

\* \* \* \* \*

UNITED STATES PATENT AND TRADEMARK OFFICE  
**CERTIFICATE OF CORRECTION**

PATENT NO. : 6,079,998  
DATED : June 27, 2000  
INVENTOR(S) : Kamath

Page 1 of 1

It is certified that error appears in the above-identified patent and that said Letters Patent is hereby corrected as shown below:

Abstract,

Line 5, delete "sandwiching" and insert -- sandwich --

Column 3,

Line 34, change "member" to -- members --

Column 4,

Line 47, before "first connector" add -- a --

Line 52, before "deflecting member" add -- a --

Line 54, change "member" to -- means --

Line 57, change "means" to -- member --

Line 67, change "deflecting" (second occurrence) to -- cam --

Column 5,

Line 2, change "deflecting" to -- cam --

Line 4, change "deflecting" (second occurrence) to -- cam --

Line 6, change "deflecting" to -- cam --

Signed and Sealed this

Twenty-fifth Day of September, 2001

Attest:

*Nicholas P. Godici*

Attesting Officer

NICHOLAS P. GODICI  
Acting Director of the United States Patent and Trademark Office