



US006079952A

United States Patent [19]

[11] Patent Number: **6,079,952**

Harte et al.

[45] Date of Patent: **Jun. 27, 2000**

[54] **CONTINUOUS CAPACITY CONTROL FOR A MULTI-STAGE COMPRESSOR**

[75] Inventors: **Shane Anthony Harte**, Dearborn; **Lavlesh Sud**, Farmington Hills; **Yong Huang**, Ann Arbor, all of Mich.

[73] Assignee: **Ford Global Technologies, Inc.**, Dearborn, Mich.

[21] Appl. No.: **09/018,225**

[22] Filed: **Feb. 2, 1998**

[51] Int. Cl.⁷ **F04B 3/00**; F01C 1/30

[52] U.S. Cl. **417/53**; 417/253; 418/6

[58] Field of Search 417/53, 253, 252, 417/310; 418/6, 11, 59, 3, 13, 1

5,015,161	5/1991	Amin et al.	418/6
5,074,760	12/1991	Hirooka et al.	417/310
5,074,761	12/1991	Hirooka et al.	417/310
5,201,189	4/1993	Yokomachi et al.	62/196.3
5,284,426	2/1994	Strikis et al.	418/6
5,399,076	3/1995	Matsuda et al.	418/6

FOREIGN PATENT DOCUMENTS

565263	11/1944	European Pat. Off. .
3536714	10/1985	Germany .
59-77095	10/1982	Japan .
59-99089	11/1982	Japan .
62-81588	10/1985	Japan .
2-204694	8/1990	Japan .

Primary Examiner—Henry C. Yuen
Assistant Examiner—Mahmoud M. Gimie
Attorney, Agent, or Firm—Frank G. McKenzie

[56] References Cited

U.S. PATENT DOCUMENTS

862,867	8/1907	Eggleston	418/6
2,759,664	8/1956	Auwarter	230/152
2,820,415	1/1958	Born	103/37
3,402,891	9/1968	Clark et al.	239/127
3,680,980	8/1972	Bart	417/253
3,692,052	9/1972	Cattanach	137/561
4,061,443	12/1977	Black et al.	417/222
4,505,653	3/1985	Roberts	418/23
4,566,863	1/1986	Goto et al.	417/295
4,744,733	5/1988	Terauchi et al.	417/310
4,892,466	1/1990	Taguchi et al.	417/295
4,904,164	2/1990	Mabe et al.	417/308
4,976,592	12/1990	Nakajima et al.	417/295

[57] ABSTRACT

A control strategy for a multiple stage rotary compressor having compressive capacity output based on the demand of an air conditioning system. The constant variance in capacity to meet demand is obtained by recirculation of the multiple stages. Capacity is reduced to less than full capacity by recirculating the output of each stage back to the input of that particular stage. Capacity is increased up to full capacity by decreasing recirculation of the output of each stage back to the input of that particular stage. Additional stages and or portions operate in the same manner and provide further recirculation variability to provide a recirculation schedule based on demand.

19 Claims, 10 Drawing Sheets

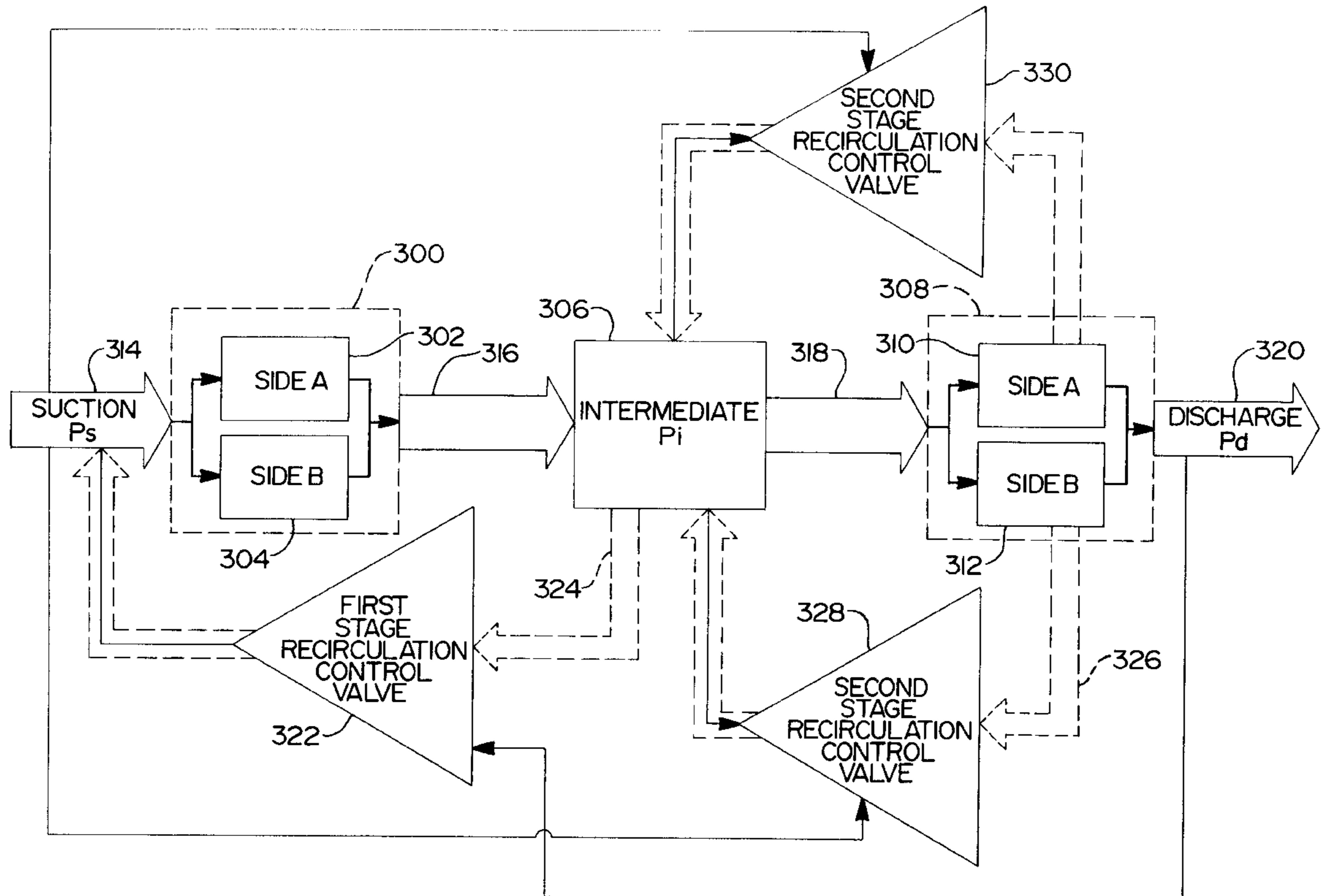

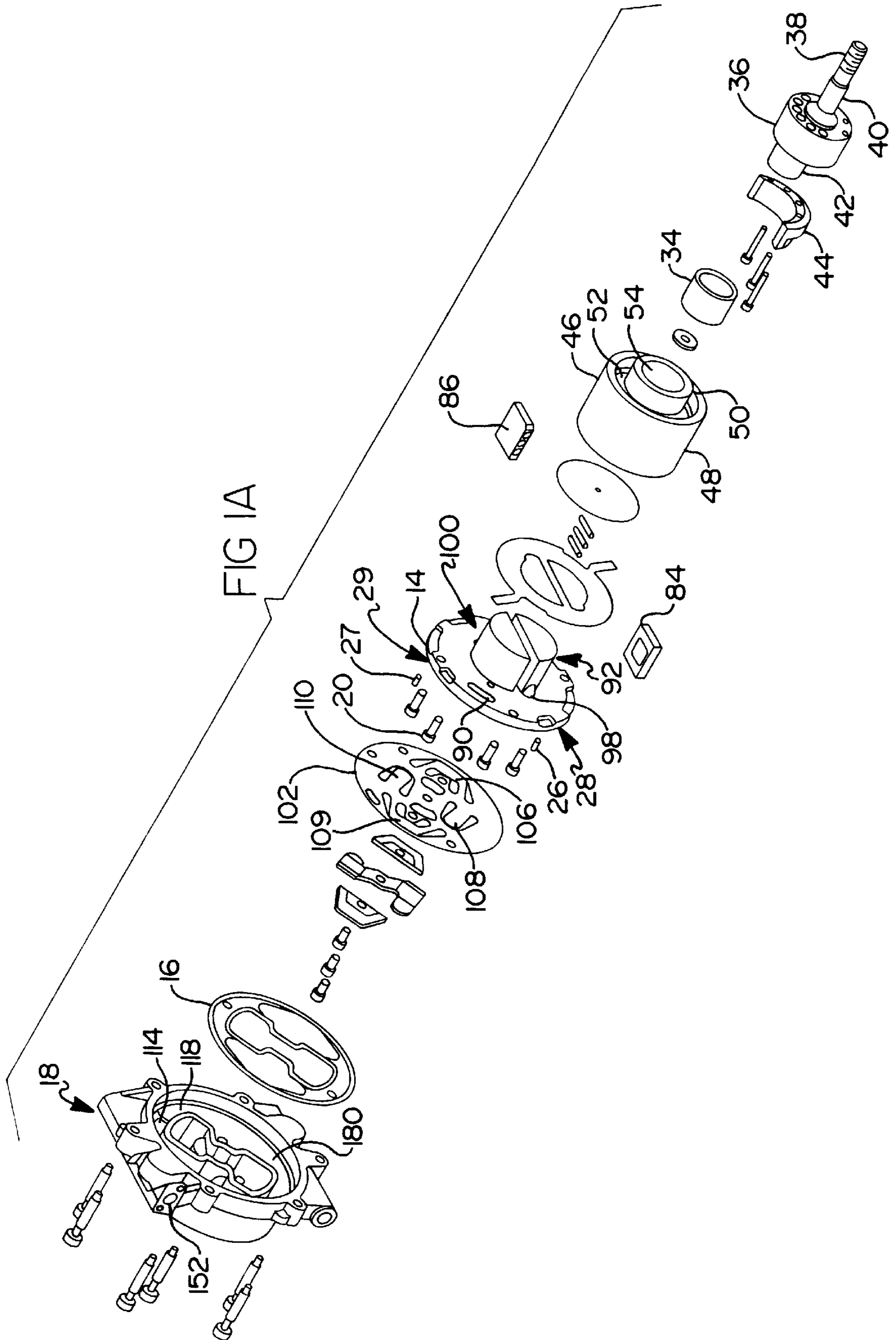

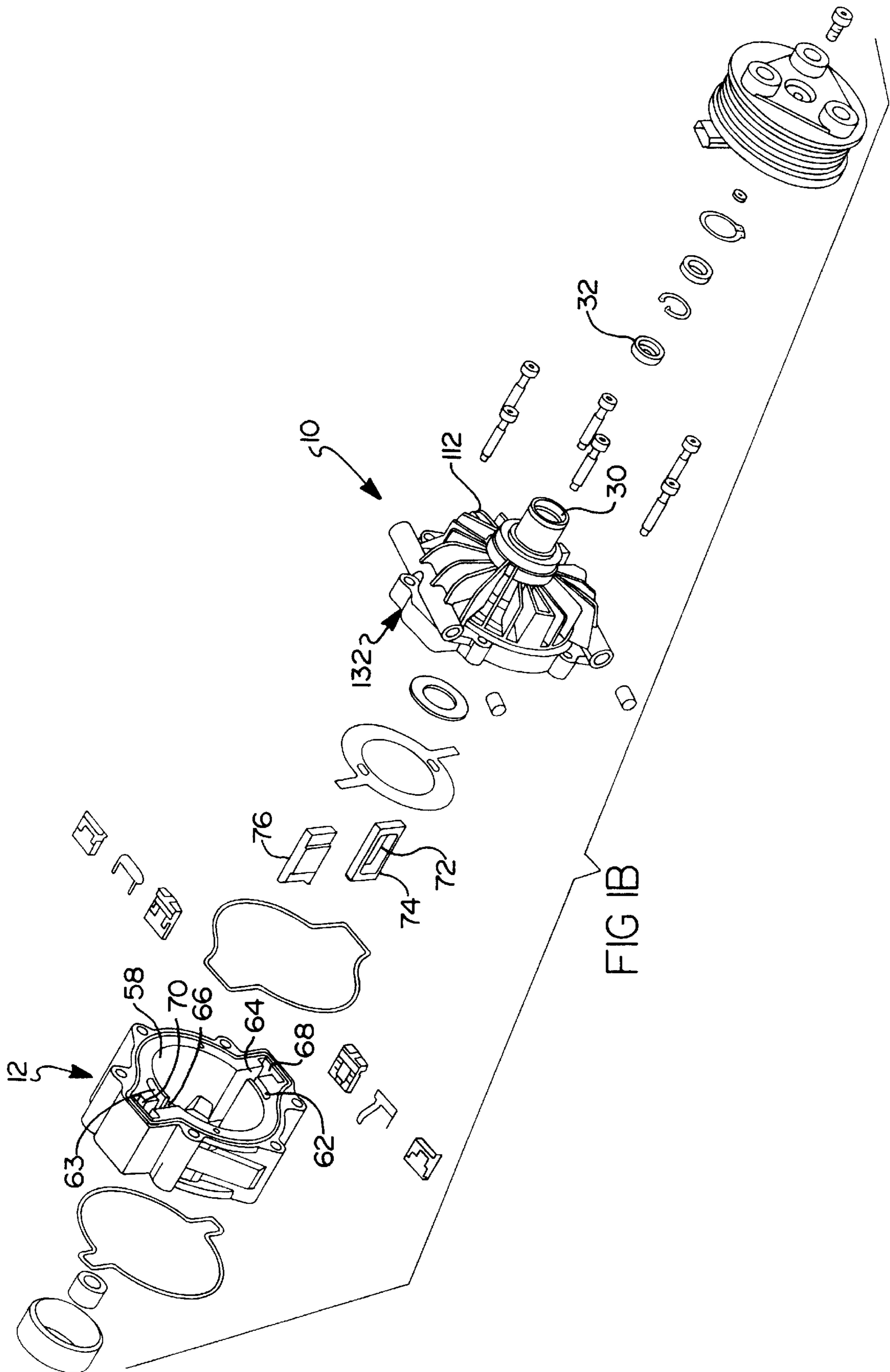
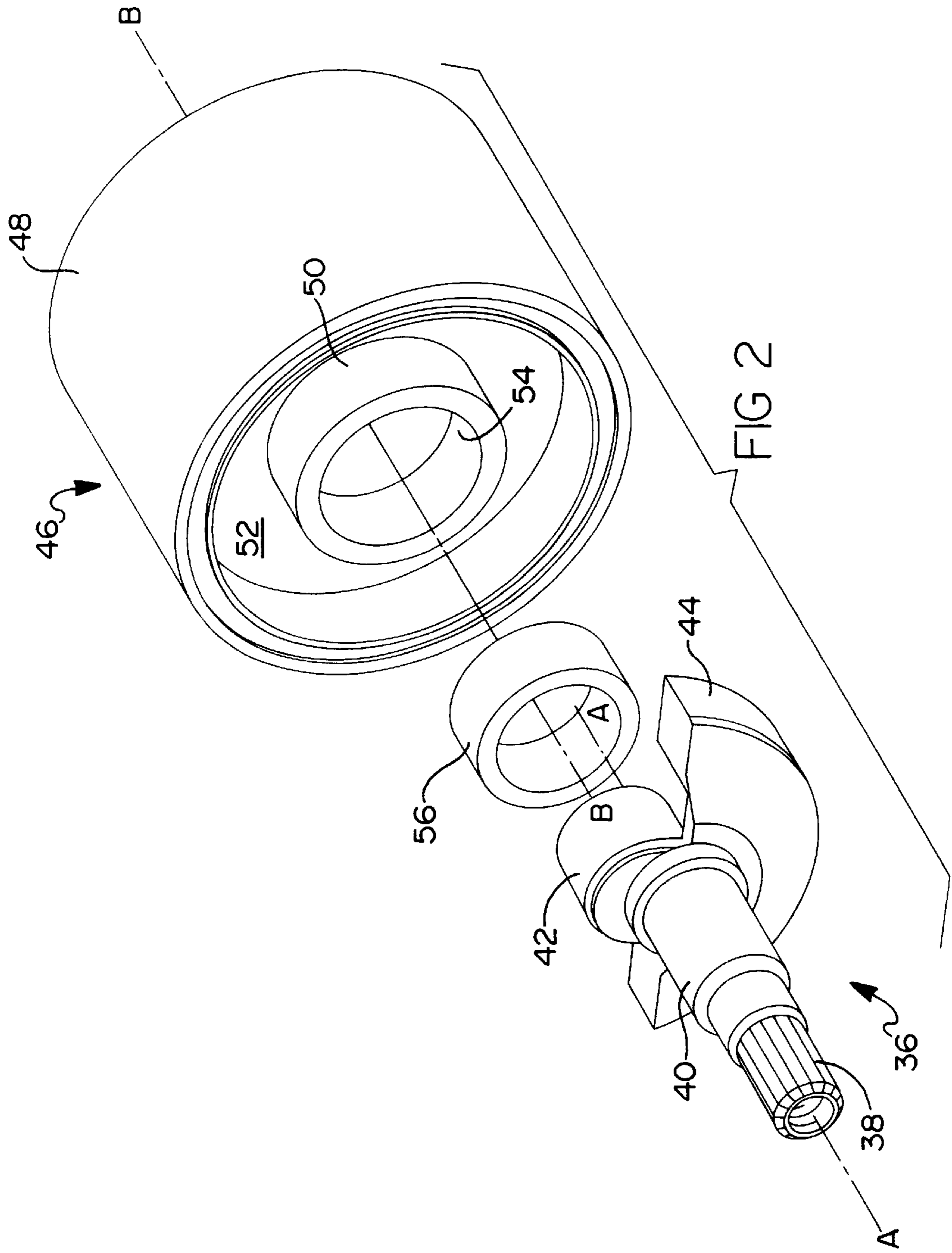

FIG 1B



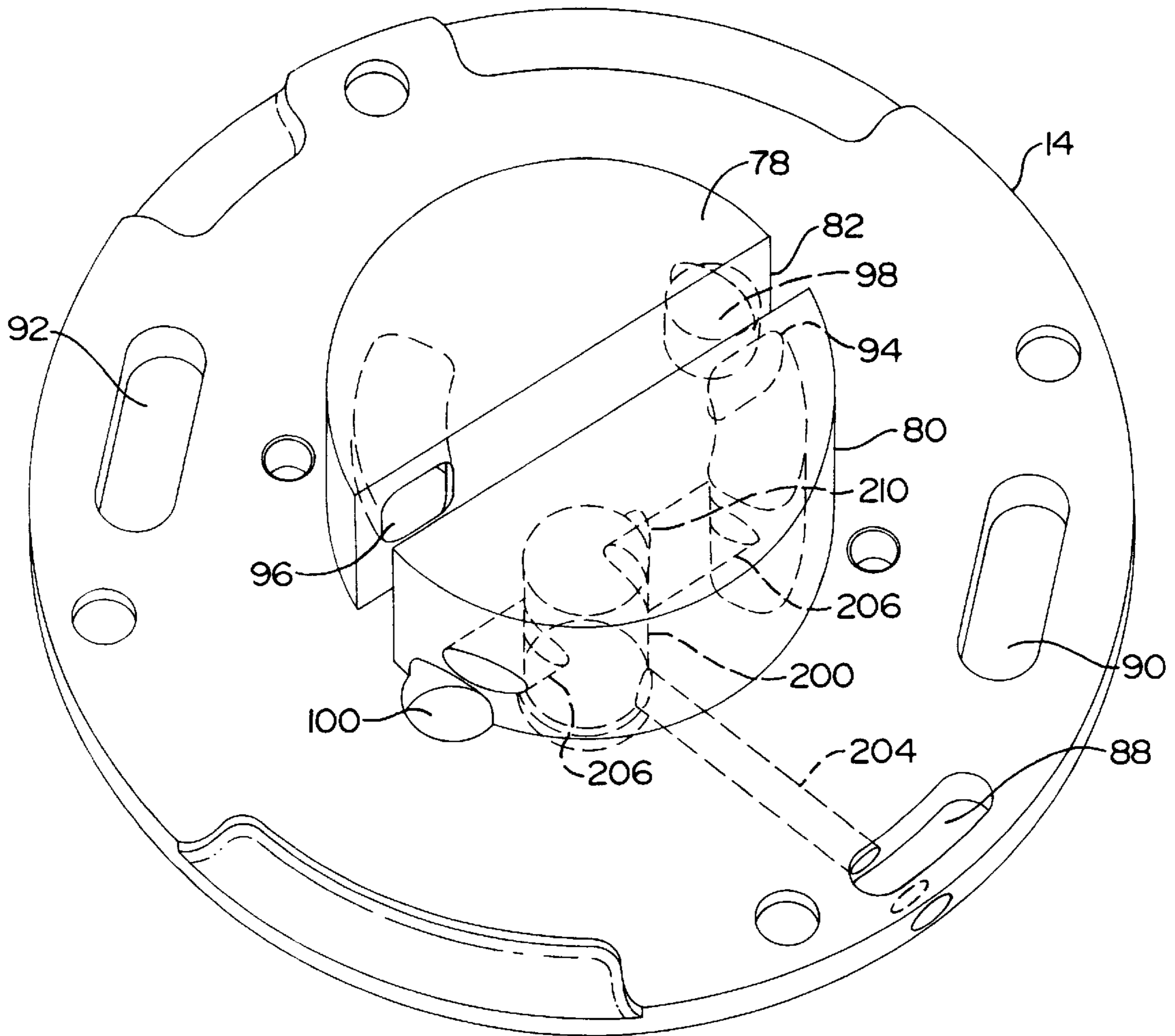
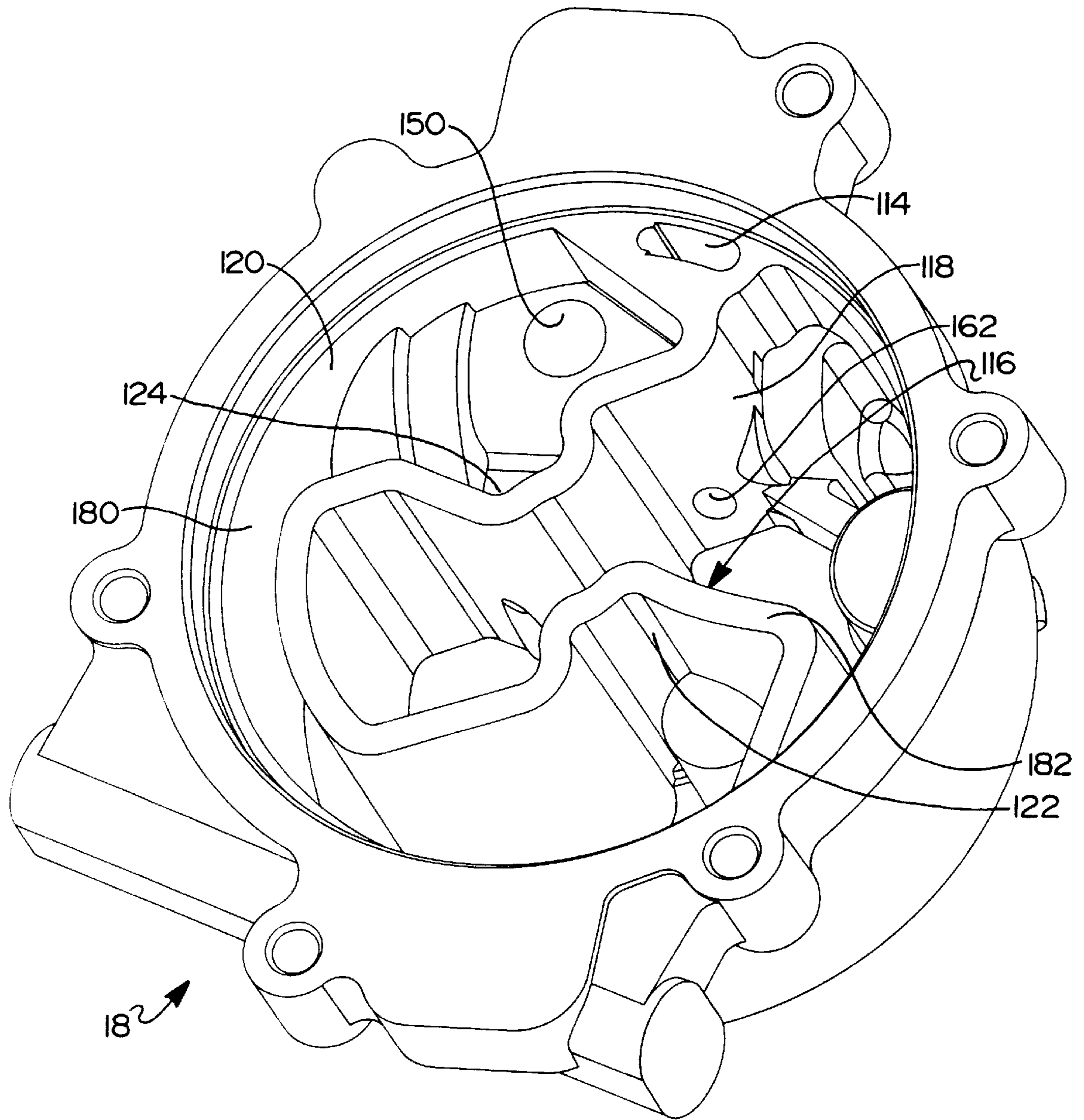

FIG 3

FIG 4



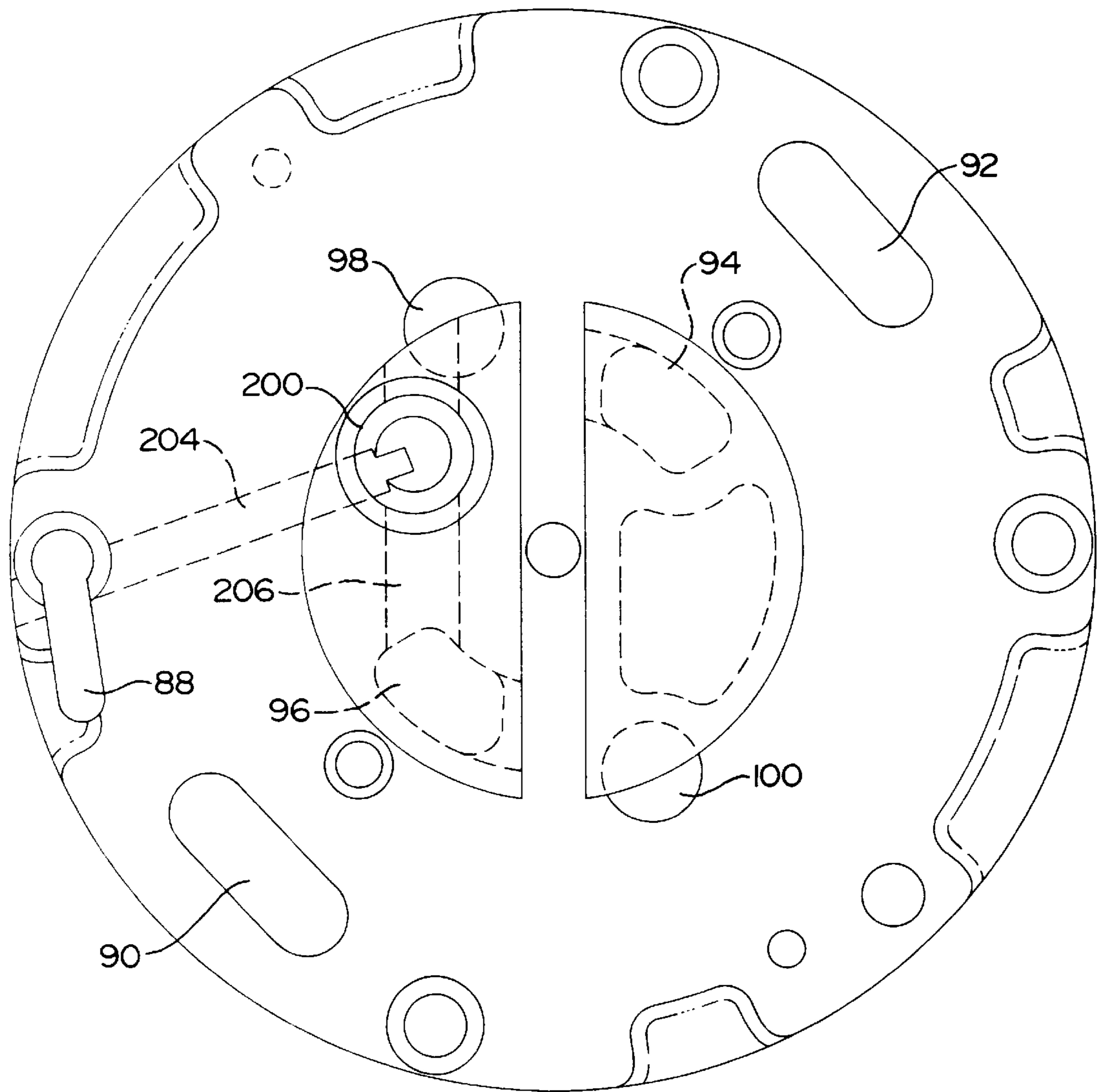
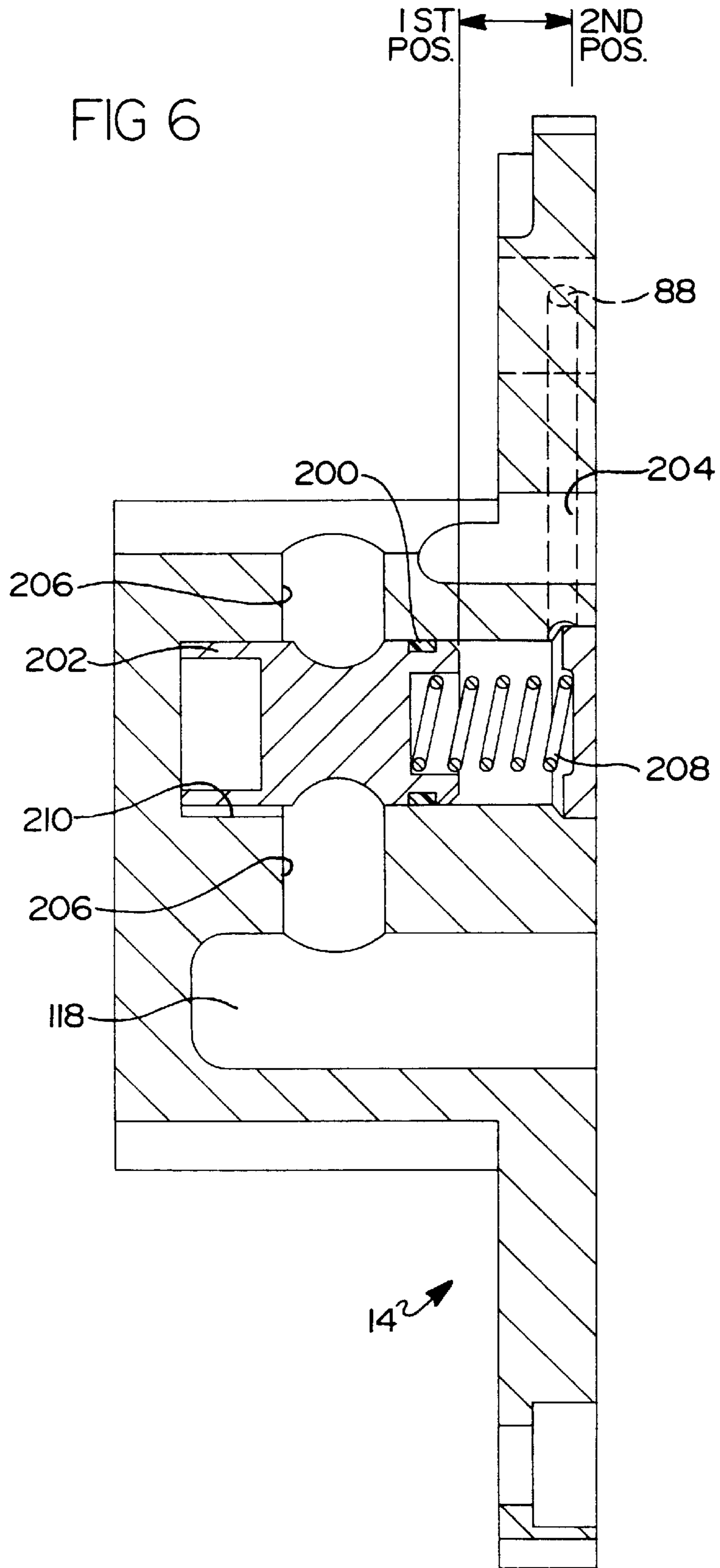
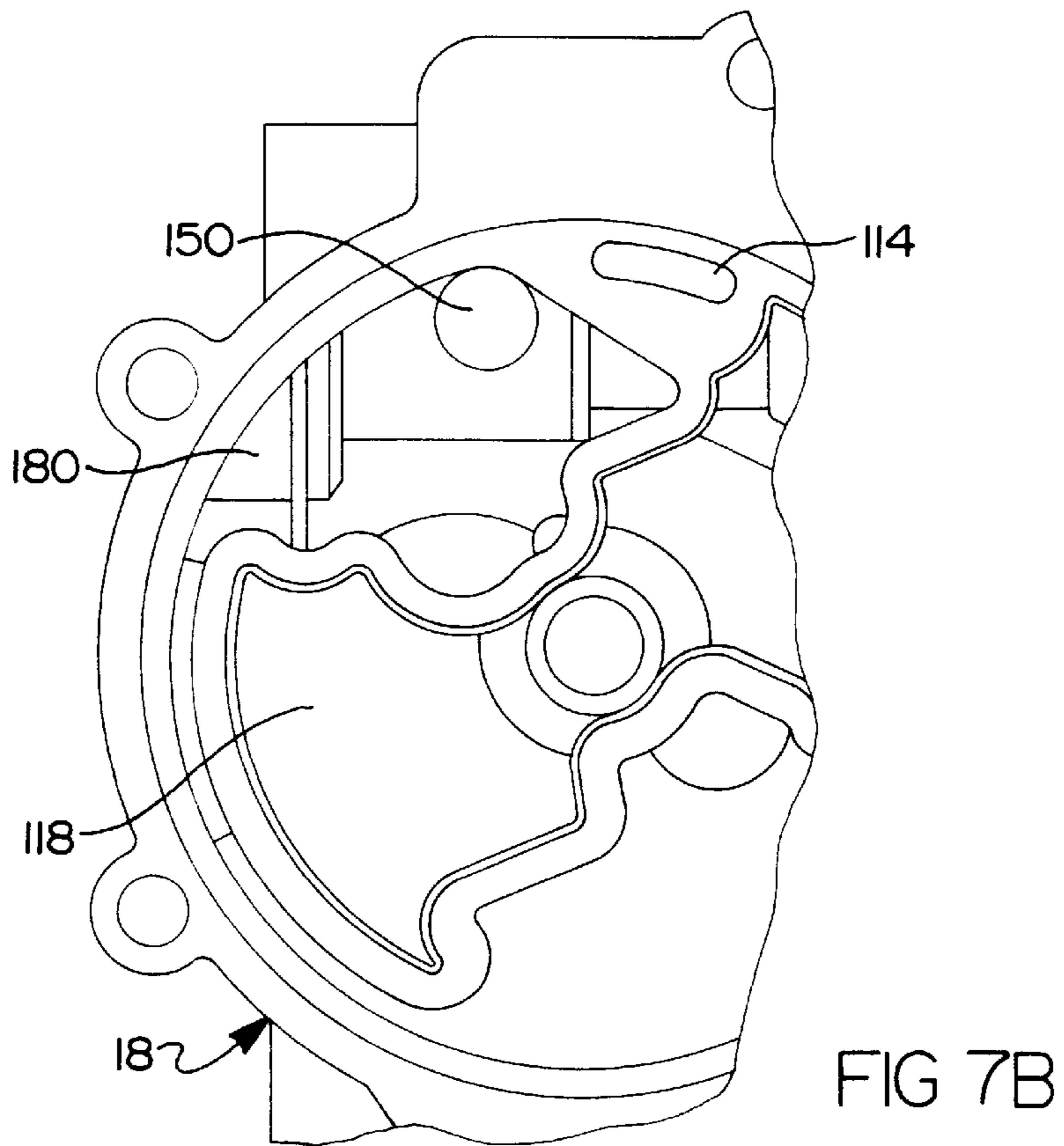
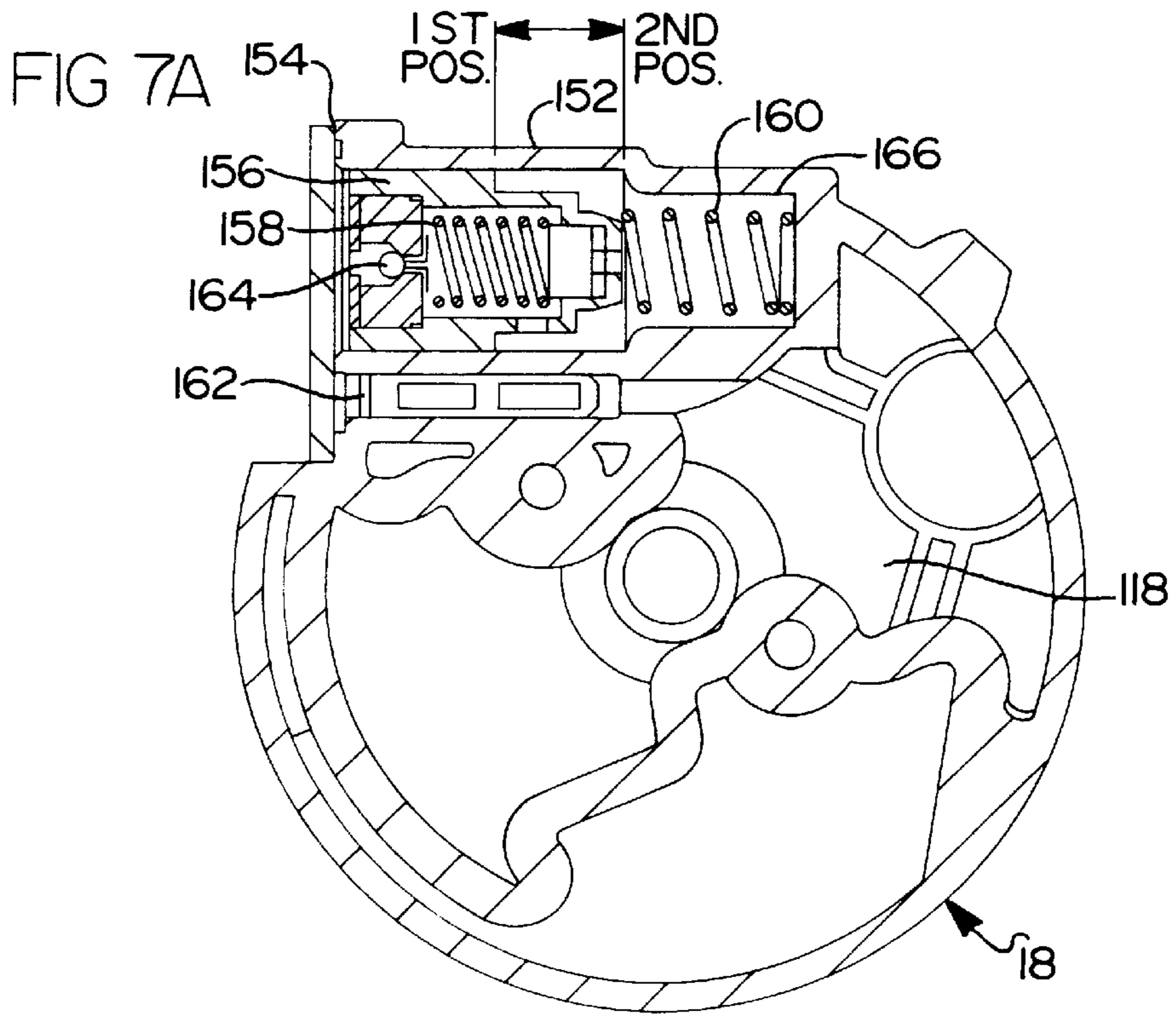

FIG 5

FIG 6





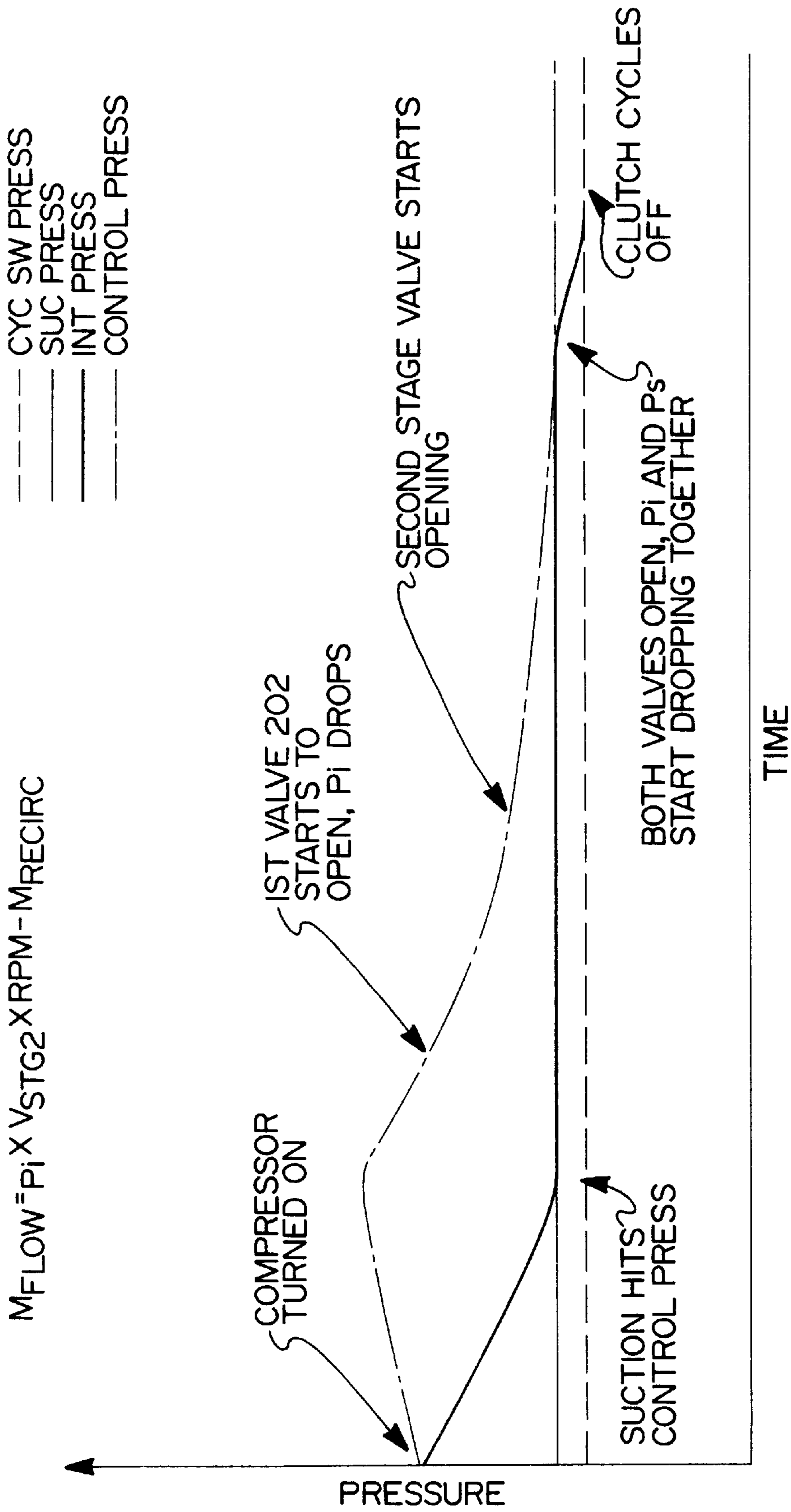
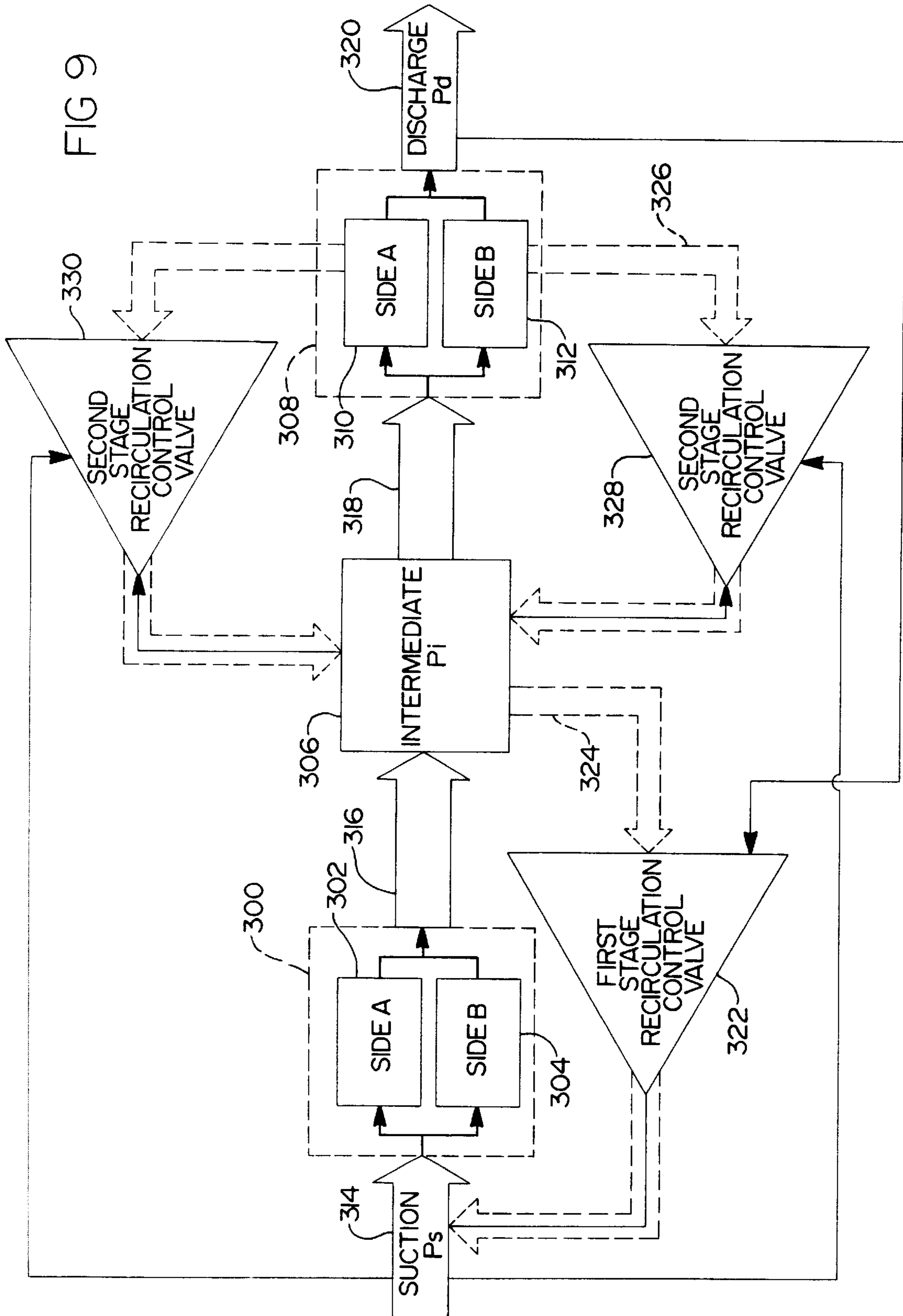

FIG 8

FIG 9



CONTINUOUS CAPACITY CONTROL FOR A MULTI-STAGE COMPRESSOR

BACKGROUND OF THE INVENTION

1. Field of the Invention

The instant invention relates to rotary compressors for automotive climate control systems. More particularly, the instant invention relates to a multi-stage rotary piston compressors having a plurality of valves to obtain continuous capacity control.

2. Description of the Related Art

When the air conditioning load in the passenger compartment of a vehicle is below a predetermined temperature, the displacement of a compressor within an air conditioning system of the vehicle can be decreased. This will result in a reduced compression ratio in the compressor and therefore a reduced cooling capacity.

It is known to vary the capacity of a compressor dependent upon operating requirements. An example of a compressor having capacity control is disclosed in U.S. Pat. No. 5,284,426, which is assigned to the assignee of the present invention. The '426 patent describes a refrigerant gas compressor having variable capacity control achieved by selectively disabling the outer vanes that cooperate with the outer perimeter of the orbiting ring piston. Either one or both of two outer vanes can be selectively disabled. However, the '426 patent decreases the compressor capacity in discrete steps.

It is also known to vary the capacity of a single stage compressor by valve means. An example of a single valve in a scroll type compressor is provided by Terauchio et al., U.S. Pat. No. 4,744,733. An example of such in a rotary type compressor is Goto et al., U.S. Pat. No. 4,566,863, which also teaches a single valve to open and close a by-pass passage.

However, neither Terauchio nor Goto provide the functional flexibility to match directly the compressor capacity with demand and neither teach how to do so with a compressor having multiple stages. The use of a single valve strictly limits the functional operating range of the capacity control. The limited functional range limits the decrease in parasitic losses and the overall horsepower savings of the air conditioning system. Further, the prior art compressors can only provide a restricted cycling map, in which it is necessary to cycle the compressor on/off with great frequency. The increased cycling frequency creates torque shock thereby increasing noise and vibration during compressor operation.

It is desirable to provide a multi-stage rotary piston compressor for automotive climate control systems which directly regulates compression volume in relation to demand. It is still further desirable to provide a multi-stage rotary piston compressor with a significantly increased cycling map.

SUMMARY OF THE INVENTION

Responsive to the disadvantages of the prior art, the instant invention provides improvements to a multi-stage orbiting ring piston compressor disclosed in U.S. Pat. No. 5,015,161, which is assigned to the assignee of the instant invention. The instant invention is characterized by a plurality of valves operative to directly regulate compression volume in relation to demand while providing a significantly increased cycling map.

According to a principal feature of the instant invention, the variable capacity control is achieved by a plurality of

valves operating simultaneously in relation to a control pressure. Thus, it is not necessary to operate the compressor at maximum capacity when only partial load is demanded by the operating environment for the air conditioning system.

Further, by providing a plurality of valves operating simultaneously in relation to a control pressure the instant invention provides a significantly increased cycling map, i.e., the variation of compressor pressure with time resulting from control valve operation. This provides nearly continuous operation in which it is unnecessary to cycle the compressor on/off. Therefore, parasitic losses associated with driving the compressor are minimized. The frequency of torque shock, noise and vibration during compressor operation are minimized also.

According to one embodiment of the instant invention a multi-stage rotary gas compressor for compressing a fluid is disclosed. The compressor housing defines a compression chamber having an inner surface with a first axis, a post substantially coaxial with respect to the compression chamber having an outer surface, and an orbital ring piston mounted for orbital movement about a second geometric axis, the orbital ring piston being offset relative to the first geometric axis. The outer surface of the orbital ring piston is adapted to contact said compression chamber inner surface, and an inner surface is adapted to contact the outer surface of the post.

The housing carries outer vanes, adapted to move into engagement with the orbital ring piston outer surface, and inner vanes, mounted on the post adapted to engage the orbital ring piston inner surface. The outer vanes cooperate with the orbital ring piston and the compression chamber to define a first-stage having first and second compression chamber portions. The inner vanes cooperate with the orbital ring piston and the post to define a second-stage having third and fourth compression chamber portions.

First-stage inlet ports and first-stage outlet ports are located within the housing and communicate with first and second compression chamber portions. Second-stage inlet ports and second-stage outlet ports are located in the housing and communicate with the third and fourth compression chamber portions.

An intermediate compression chamber is further located within the housing and connects the first-stage outlet ports with the second-stage inlet ports. A first-stage by-pass passage is formed through the housing between the intermediate compressor chamber and at least one of the first-stage inlet ports. A second-stage by-pass passage is formed through the housing between at least one second-stage outlet port and the intermediate compressor chamber.

A first-stage control valve means within the housing defines a first-stage control chamber and a valve set to operate at a predetermined first-stage control pressure, the valve being movable between a first position and a second position and biased towards the first position by a spring. The first position of the valve thereof at least partially opens the first-stage by-pass passage, and a second position thereof closes the first-stage by-pass passage.

A first first-stage communication channel formed through the housing between said first-stage inlet ports and the first control valve provides a first-stage suction pressure. A second first-stage communication channel is formed through the housing between the first-stage outlet ports and the first-stage control chamber. The first-stage communication channel provides a first-stage discharge pressure urging the first valve member towards the second position.

The first-stage valve member, shifts towards the first position when the first-stage suction pressure is equivalent to

the first-stage control pressure, whereby the first-stage discharge pressure is insufficient to overcome the valve biasing spring.

A second-stage control valve means within said housing includes a valve member movable between a first position at least partially opening the second-stage by-pass passage and a second position closing the second-stage by-pass passage, the valve being biased towards the first position by a spring.

A first second-stage communication channel formed through the housing between the first-stage inlet ports and second-stage control valve means provides a first-stage suction pressure. The first-stage suction pressure urges the second-stage valve member towards the first position.

A second second-stage communication channel formed through the housing between the intermediate compression chamber and the second-stage valve provides an intermediate pressure urging the valve member towards the second position. The second-stage valve shifts towards the first position when the difference between the first-stage suction pressure and the intermediate pressure is insufficient to overcome the valve biasing spring.

In another embodiment of the instant invention, the second-stage valve means comprise an independent member for each second-stage compressor portion, each valve member and associated passages located within the compressor housing.

Accordingly, an object of the instant invention is to provide a multi-stage rotary piston compressor having continuous capacity control directly relating compressor capacity with demand.

An advantage of the instant invention is the use of a plurality of valves, which limit capacity in proportion to demand. A further advantage is operating the compressor in relation to a control pressure to provide a significantly increased cycling map.

These and other desired objects of the instant invention will become more apparent from the following detailed description and appended claims. The invention may best be understood with reference to the accompanying drawings wherein illustrative embodiments are shown.

BRIEF DESCRIPTION OF THE DRAWINGS

FIG. 1 is an isometric view showing components of the compressor displaced axially from one another and arranged generally in the order of assembly.

FIG. 2 is an isometric view showing the face of the orbiting ring, bushing and crankshaft.

FIG. 3 is an isometric view showing the front face of the rear plate.

FIG. 4 is an isometric view showing the interior face of the rear head.

FIG. 5 is a front view showing the front face of the rear plate and the location of the fluid passages.

FIG. 6 is a cross section through the rear plate showing the second-stage control valve and associated fluid passages.

FIGS. 7a and 7b are end views of the rear head showing the first-stage control valve and associated fluid passages.

FIG. 8 is a representation of a cycling map for a multi-stage compressor of the instant invention.

FIG. 9 is a schematic diagram of a system, according to this invention, for controlling a multi-stage fluid compressor.

DETAILED DESCRIPTION OF THE PREFERRED EMBODIMENTS

The instant invention will be described through a series of drawings, which illustrate the multi-stage rotary piston

compressor having full capacity control of the instant invention. Referring first to FIG. 1, the housing of a gas compressor includes a front head 10, center housing 12, rear gasket 16 and rear head 18. These components and rear plate 14 are mutually connected by passing tension bolts 20 through four aligned bolt holes formed in engaging threads tapped in the center housing 12. Dowel pins 26, 27 located within holes 28, 29 in the rear face of the rear plate maintain alignment of the gasket.

The front head includes a cylindrical bore 30 having a small diameter sized to receive a hydraulic seal 32 and a larger diameter sized to receive roller bearing 34. The bearing rotatably supports a crankshaft 36, which includes a spline surface 38 for drivably connecting the crankshaft to the sheave of a drivebelt assembly.

Referring next to FIG. 2, a cylindrical shoulder 40 is fitted within the bearing concentrically with axis A—A, eccentric 42 has a cylindrical surface whose axis B—B is offset radially from axis A—A, and a large cylindrical surface 44 is coaxial with A—A. An orbiting ring 46 includes a cylindrical outer surface 48 coaxial with B—B, a cylindrical boss 50 joined by a web 52 to the outer surface defines a central bore 54 concentric with axis B—B. Bushing 56 is fitted within bore 54 and rotatably supports eccentric 42 on the orbiting ring.

FIG. 1 further shows a center housing 12 that includes a cylindrical inner surface 58 on which the outer cylindrical surface 48 of the orbiting ring rolls, a suction passage 62 through which incoming low pressure gas flows, and outer vane slots 64, 66 in which vanes 74, 76, slide into contact with the outer surface of the orbiting ring 46. Inlet passages 68, 70, communicating respectively with passages 62, 63, carry refrigerant at suction pressure to inlet pocket 72, 73 formed on the lateral, inner faces of the outer vanes 74, 76, respectively.

A valve plate 102, formed of spring steel, seats within a circular recess formed on the rear face of plate 14 and defines four reed valves: first and second first-stage discharge valves 104, 106 for opening and closing passages 90, 92; and first and second second-stage discharge valves 108, 110 for opening and closing passages 98, 100.

Gasket 16, located between the adjacent faces of the rear head and center housing, seals intermediate and discharge plenums.

Referring now to FIGS. 1, 3 and 5, rear plate 14 includes a post 78 having an outer cylindrical surface 80 coaxial with axis A—A, sized to fit within the orbiting ring and located within center housing 12. The post 78 contains a transverse diametric slot 82, within which internal vanes 84, 86 are mounted for sliding radially outward directed movement into contact with the inner surface of the orbiting ring 46. The rear plate also includes a suction passage 88 aligned with passage 62, first-stage-discharge passages 90, 92, intermediate or second-stage inlet passages 94, 96, and second-stage discharge passages 98, 100.

The rear plate 14 further includes at least one second-stage control valve bore and at least one second-stage control valve 202 located in bore 200. A first second-stage control passage 204 is formed through the rear plate 14 between the first-stage suction pressure source 88 and the low pressure side of the second-stage control valve bore 200. A second second-stage control passage 210 formed through the rear plate 14 between intermediate compressor chamber 118, passage 206 and the high pressure side of the second-stage control valve bore 200.

Referring to FIG. 6, the second-stage control valve 202 is movable between a first position thereof at least partially

opening the second-stage by-pass passage **206** and a second position thereof closing the second-stage by-pass passage **206**. Contained within the control valve bore **200** is a spring **208** biasing the second-stage control valve member **202** towards the first position. The first second-stage channel **204** carries first-stage suction pressure bore **200**, also urging the second-stage control valve **202** towards its first position.

The second second-stage communication channel **210** carries intermediate pressure, i.e., pressure between the discharge side of the first stage and inlet side of the second stage, which urges the second-stage control valve **202** towards the second position at the lower end of bore **200**. The second-stage control valve **202** shifts towards the first position when the net pressure force on the valve resulting from first-stage suction pressure and intermediate pressure is insufficient to overcome the biasing force of spring **208**.

Referring again to FIG. 1, front head **10** includes a suction port **112**, suction passage **132**, aligned and communicating with suction passage **62**, **63**.

Referring to FIGS. 1 and 4, the discharge port, that connects the discharge side of the first stage and the intermediate pressure chamber **180** communicating with the interior of discharge pressure chamber **118** is integrally cast with the body of the rear head. Surrounding discharge pressure chamber **118**, the walls of the rear head define a space, the intermediate pressure chamber **180**, located within the inner surface **120** of the side walls of the rear head. Gas at first-stage discharge pressure flows through passages **122**, **124** defined by the waist of intermediate chamber **118**. Passages **122**, **124** are aligned with intermediate pressure passages **94**, **96** formed through the thickness of rear plate **14** and the length of post **78**, through which gas compressed in the first-stage is carried to and enters the second stage.

Referring next to FIGS. 1, 4, 7a and 7b, rear head **18** further includes a first-stage by-pass passage **150** formed between the intermediate pressure chamber **180** and at least one of the first-stage suction passages **114**. The first-stage valve bore **152** is located in rear head **18** and defines a high-side control chamber **154**, a low-side control chamber **166**, and contains the first-stage valve member **156** located therebetween. The high-side control chamber **154** directly communicates by a restricted flow orifice tube **162** to second-stage discharge. The low-side pressure communicates with first-stage suction and contains an internal bellows mechanism **158** that is operative to open the ball valve **164** in the first-stage control valve **156**. The ball valve **164** allows communication between the high-side chamber **154** and the low-side chamber **166**.

When the ball valve **164** is closed, full second-stage discharge pressure is achieved in the high-side chamber **154**. The action of the pressure differential overcomes the force of spring **160** and maintains the first-stage valve member **156** in the second position, at the right-hand end of bore **152**.

When the ball valve **164** begins to open, the pressure in the high-side chamber **154** reduces as the ball valve **164** opening is of a greater diameter than that of the orifice tube **162**. The reduced pressure in the high-side chamber **154** is insufficient to overcome the force of spring **160** and the first-stage valve member **156** is urged toward the first position, at the left-hand extremity of bore **152**.

The rear face of front head **10** defines an annular passage **132** located between the inner surface of its wall and the outer surface of journal **134**, on which the crankshaft **40** is rotatably supported. Passage **132** connects suction passage **136**, which communicates with suction passages **62**, **88**, **114**,

to first-stage inlet passage **138**, which communicates with inlet passage **63** formed in the center housing. In this way, suction pressure is continually present in inlet passages **68**, **70** and is communicated through the recesses or pockets **72**, **73** formed on the surfaces of the outer vanes, through which gas at suction pressure is admitted to the first stage.

Details of the operation of a multi-stage compressor having fixed capacity control are disclosed in U.S. Pat. No. 5,015,16, which is incorporated herein by reference.

A multi-stage compressor having at least two valves provides mass flow according to the following equation:

$$M_{flow} = \rho_f \times V_{stage2} \times RPM - M_{recirculation}$$

where mass flow is equal to the intermediate pressure density ρ_f multiplied by the volume of stage **2** V_{stage2} multiplied by the speed of the compressor RPM, minus the mass recirculated valve flow $M_{recirculation}$. A representation of a cycling map for a multi-stage compressor having a plurality of valves is presented in FIG. 8.

FIG. 8 demonstrates that when the compressor output is greater than required, the output is reduced by opening the first-stage valve **156** to allow the intermediate pressure to bypass back to first-stage suction. When the first-stage valve **156** is fully open the intermediate pressure is equivalent to first-stage suction. The first-stage is thus effectively removed from the capacity of the compressor. Further reduction in compressive capacity is obtained by modulating the second-stage valve **202**.

First-stage Valve Operation.

While the compressor is operating at maximum capacity, the first-stage suction pressure is above the control pressure of the chamber that contains bellows **158** within the first-stage valve member **156**. This control pressure is dependent upon the internal pressure of the bellows **158**. Second-stage discharge pressure acts on the left hand side of the first-stage valve **156** and only first-stage suction pressure acts on its other side. At this point the first-stage biasing spring **160** is unable to actuate the bellows **158** and move the first-stage control valve **156** towards the first position. The fully closed first-stage valve **156** therefore prevents any bypass flow from the intermediate pressure chamber back to first-stage suction. The first-stage valve **156** remains fully closed as long as the first-stage suction pressure is greater than the control pressure.

When the first-stage suction pressure reaches equilibrium with the control pressure of the bellows **158** contained within the first-stage valve **156** the first-stage valve **156** begins to open a connection through first-stage bypass passage **150** between the intermediate pressure cavity **180** and first-stage suction **114**. As the valve continues to open, flow of coolant from the first stage recirculation flow increases. As this flow increases the trend is for the intermediate pressure density to drop towards suction pressure. As can be seen in the equation above and in FIG. 8, the mass flow capacity drops linearly with intermediate pressure density.

Second-stage Valve Operation.

Referring to FIG. 6, second-stage recirculation begins with full intermediate pressure acting on the upper end of the second-stage valve spool **202**, first-stage suction pressure acting on the lower end of the spool while the force biasing spring **208** is unable to move the second-stage valve spool **202** towards the first position at the top of the valve chamber **200** where the valve partially opens passage **206** through the valve.

The second-stage valve spool **202** begins to modulate by more fully opening passage **206** when intermediate pressure

rises relative to suction pressure in passage 204. The second-stage control pressure at which valve 202 modulates is determined by the force of spring 208 and the pressure difference across the valve member 202 times the pressure areas of the valve spool 202.

As intermediate pressure drops, the difference between the first-stage suction pressure and the intermediate pressure is insufficient to overcome the spring force. The second-stage valve member 202 then begins to shift towards the first position.

As the intermediate pressure and first-stage suction pressure obtain equilibrium, the biasing spring 208 is able to fully move the second-stage valve member 202 to the first position. Where compressive capacity is reduced to the maximum mass recirculation allowed by the valves.

In another embodiment of the instant invention a second valve is located in the second-stage to allow further reduction in compressive capacity. The second second-stage valve operates the same as the first second-stage valve and further extends the cycling map shown in FIG. 8.

Once the second-stage control valves have been fully opened and maximum mass recirculation is reached, the only way to further reduce compressor output is to further reduce suction pressure. This is again accomplished by switching the compressor off preferably by disengaging a clutch that connects and releases the compressor and a power source. Finally, as the pressure requirement rises to the cycling on pressure, the compressor is reconnected to the power source and the cycle map begins again.

Referring to FIG. 9, an overall control strategy diagram for a multi-stage compressor of the instant invention is presented. The compressive capacity output of a multi-stage compressor is based on the demand of an air conditioning system. The constant variance in capacity to meet demand is obtained by recirculation of fluid in the multiple stages. Capacity is reduced to less than full capacity by recirculating the output of each stage back to the input of that particular stage. Capacity is increased up to full capacity by decreasing recirculation of that particular stage. Additional stages and or portions operate in the same manner and provide further recirculation variability to provide a recirculation schedule based on demand, such as the cycle map shown in FIG. 8.

FIG. 9 further shows the recirculation strategy of a multi-stage compressor having a first-stage 300 having first-stage compressor portions 302, 304, an intermediate chamber 306, and a second-stage 308 having second-stage compressor portions 310, 312. Fluid is introduced into the system at the first-stage input 314 and is compressed in first-stage 300 by first-stage compressor portions 302, 304. The compressed first-stage output 316 of the first-stage 300 is introduced into the intermediate chamber 306. Fluid in the intermediate chamber 306 provides second-stage input 318 to the second-stage 308 and is further compressed by second-stage compressor portions 310, 312. After complete compression in the second-stage 308 the fully compressed fluid is finally discharged through the compressor discharge 320.

Compressive capacity is reduced by recirculation of the first-stage 300 and second stage 308. First-stage recirculation is controlled by the relationship between the compressor suction pressure 314 and the compressor discharge pressure 320 introduced into the first-stage recirculation control valve 322. As demand on the air conditioning system is decreased the first-stage recirculation control valve 322 begins to open and allow first-stage recirculation 324 bleedback from the intermediate chamber 306 to first-stage input 314. First-stage compressive capacity is further reduced as first-stage

recirculation control valve 322 opens and ultimately provides full first-stage recirculation, thereby effectively eliminating first-stage compressive capacity.

The second-stage recirculation 326 is controlled by the relationship between compressor suction pressure 314 and intermediate pressure 306 introduced into the second-stage recirculation control valve 328. As demand on the air conditioning system is further decreased the second-stage recirculation control valve 328 begins to open and allow second-stage recirculation 326 to bleedback from the second-stage compressor portion 312 to intermediate chamber 306. Second-stage 308 compressive capacity is further reduced as second-stage recirculation control valve 328 opens and ultimately provides full second-stage recirculation, thereby effectively eliminating compressive capacity.

This additive stage relationship is valid for any multiple of stages and allows each stage to be further divided into multiple portions. FIG. 9 further shows that a second second-stage recirculation control valve 328 provides additional recirculation variability. The second second-stage recirculation control valve 330 operates the same as the first the second-stage recirculation control valve 328, thereby providing further recirculation variability, which may be specifically tailored to provide the desired recirculation schedule and capacity reduction.

Once all valves have been fully opened and maximum mass recirculation reached, the output is further reduced as in the fixed capacity. This is again accomplished by modulating the compressor off using a clutch in reference to a cycling switch pressure. Finally, as the pressure requirement rises to the cycling on pressure, the compressor is cycled on and the cycle map begins again.

It is thus seen that the objects of this invention have been fully and effectively accomplished. It will be realized, however, that the foregoing preferred embodiments have been shown and described for the purpose of illustrating the functional and structural principles of this invention and are subject to change and modification by those skilled in the art without departing from the principles described. Therefore, this invention includes all modifications encompassed within the spirit and scope of the following claims:

We claim:

1. A method for controlling the compressive capacity of a multi-stage compressor based on the demand of an air conditioning system, each of said stages having an input, an output and means for compressing a fluid, said method comprising the steps of:

- operating said compressor at substantially less than full capacity by recirculating said output of each stage back to said input of said stage by opening a control valve for each stage;
- increasing the capacity in a first-stage by decreasing recirculation of said first-stage by closing the control valve for the first-stage according to a schedule based on said demand; and
- increasing the capacity in a second-stage by decreasing recirculation of said second-stage by closing the control valve for the second-stage according to a schedule based on said demand.

2. The method of claim 1 wherein said second-stage begins decreasing recirculation and increasing compressive capacity after said first-stage reaches maximum compressive capacity.

3. The method of claim 1 wherein said multi-stage compressor decreases compressive capacity by increasing recirculation of said output of said first-stage back to said input of said first-stage.

4. The method of claim 3 wherein said multi-stage compressor decreases compressive capacity by increasing recirculation of said output of said second-stage back to said input of said second-stage after said first-stage has obtained maximum recirculation and minimum compressive capacity.

5. A method for controlling the capacity of a multi-stage compressor based on the demand of an air conditioning system, said multi-stage compressor having a first-stage compression chamber, a first-stage input, a first-stage output, a second-stage compression chamber, a second-stage input, a second-stage output, means for compressing fluid in said first-stage compression chamber and said second-stage compression chamber, an intermediate chamber connecting said first-stage output and said second-stage input, first-stage control valve means communicating between said intermediate chamber and said first-stage input and second-stage control valve means communicating between said second-stage output and said intermediate chamber, said method comprising the steps of:

communicating second-stage discharge pressure to said first-stage control valve means;

communicating first-stage suction pressure to said first-stage control valve means;

biasing said first-stage control valve means in an open position to at least partially recirculate fluid from said intermediate compression chamber to said first-stage input;

closing said first-stage control valve means thereby decreasing recirculation of fluid from said intermediate compression chamber to said first-stage input when said demand exceeds said second-stage output;

communicating first-stage suction pressure to said second-stage control valve means;

communicating intermediate pressure to said second-stage control valve means;

biasing said second-stage control valve means in an open position to at least partially recirculate fluid from said second-stage output to said intermediate compression chamber; and

closing said second-stage control valve means thereby decreasing recirculation of fluid from said second-stage output to said intermediate compression chamber when said demand exceeds second-stage output.

6. The method of claim 5 wherein said valve members have step-less variable capacity.

7. The method of claim 5 wherein said multi-stage compressor increases compressive capacity by decreasing recirculation of said output of said second-stage back to said input of said second-stage after said first-stage has obtained minimum recirculation and maximum compressive capacity.

8. The method of claim 5 wherein said multi-stage compressor decreases compressive capacity by increasing recirculation of said output of said first-stage back to said input of said first-stage.

9. The method of claim 8 wherein said multi-stage compressor decreases compressive capacity by increasing recirculation of said output of said second-stage back to said input of said second-stage.

10. The method of claim 9 wherein said multi-stage compressor decreases compressive capacity by increasing

recirculation of said output of said second-stage back to said input of said second-stage after said first-stage has obtained maximum recirculation and minimum compressive capacity.

11. The method of claim 10 wherein said multi-stage compressor decreases compressive capacity according to a predetermined schedule.

12. The method of claim 5 wherein said second-stage compression chamber further comprises a plurality of portions, said second-stage valve means having a second stage valve member in each of said second-stage compressor chamber portions.

13. A method for controlling the capacity of a multi-stage compressor based on the demand of an air conditioning system, said multi-stage compressor having a first-stage compression chamber, a first-stage input, a first-stage output, a second-stage compression chamber, a second-stage input, a second-stage output, means for compressing fluid in said first-stage compression chamber and said second-stage compression chamber, an intermediate chamber connecting said first-stage output and said second-stage input, first-stage control valve means communicating between said intermediate chamber and said first-stage input and second-stage control valve means communicating between said second-stage output and said intermediate chamber, said method comprising the steps of:

communicating second-stage discharge pressure to a control chamber through a restricted flow orifice, said control chamber pressure acting to close said first-stage control valve means;

communicating first-stage suction pressure to the opposite end of said first-stage control valve means;

biasing said first-stage control valve means open to at least partially recirculate fluid from said intermediate compression chamber to said first-stage input;

closing said first-stage control valve means thereby decreasing recirculation of fluid from said intermediate compression chamber to said first-stage input wherein said first-stage valve biasing means overcomes said control pressure;

communicating first-stage suction pressure to one end of said second-stage control valve means, said first-stage suction pressure acting to open said second-stage control valve means;

communicating intermediate pressure to the opposite end of said second-stage control valve means, said intermediate pressure acting to close said second-stage control valve means;

biasing said second-stage control valve means open to at least partially recirculate fluid from said second-stage output to said intermediate compression chamber;

closing said second-stage control valve means thereby decreasing recirculation of fluid from said second-stage output to said intermediate compression chamber wherein said second-stage control valve means closes when said intermediate pressure overcomes said first-stage suction pressure and said second-stage valve biasing means.

14. The method of claim 13 wherein said valve members have step-less variable capacity.

11

15. The method of claim **13** wherein said second-stage valve means begins operating when said first-stage valve means obtains maximum recirculation.

16. The method of claim **13** wherein said second-stage compression chamber further comprises a plurality of portions, said second-stage valve means having a second stage valve member in each of said second-stage compressor chamber portions.

17. The method of claim **13** wherein said multi-stage compressor decreases compressive capacity by increasing recirculation of said output of said first-stage back to said input of said first-stage.

12

18. The method of claim **17** wherein said multi-stage compressor decreases compressive capacity by increasing recirculation of said output of said second-stage back to said input of said second-stage.

19. The method of claim **17** wherein said multi-stage compressor decreases compressive capacity by increasing recirculation of said output of said second-stage back to said input of said second-stage after said first-stage has obtained maximum recirculation and minimum compressive capacity.

* * * * *