



US006074370A

United States Patent [19]

[11] Patent Number: **6,074,370**

Pressly, Sr. et al.

[45] Date of Patent: **Jun. 13, 2000**

[54] SAFETY SYRINGE

[75] Inventors: **William B. S. Pressly, Sr.**, Greer, S.C.;
Charles A. Vaughn, Sr., Duluth, Ga.;
G. Samuel Brockway; Thomas R. Ellis, both of Lawrenceville, Ga.

[73] Assignee: **Syringe Development Partners L.L.C.**,
Lawrenceville, Ga.

[21] Appl. No.: **09/139,008**

[22] Filed: **Aug. 24, 1998**

Related U.S. Application Data

[63] Continuation of application No. 08/783,665, Jan. 15, 1997, Pat. No. 5,800,403, which is a continuation of application No. 08/481,093, Jun. 7, 1995, Pat. No. 5,613,952, which is a continuation-in-part of application No. 08/359,001, Dec. 16, 1994, abandoned, which is a continuation of application No. 07/813,115, Dec. 23, 1991, Pat. No. 5,211,629.

[51] Int. Cl.⁷ **A61M 5/00**

[52] U.S. Cl. **604/195; 604/110; 604/218**

[58] Field of Search 604/195, 198,
604/110, 218, 222, 187, 263

[56] References Cited

U.S. PATENT DOCUMENTS

2,460,039	1/1949	Scherer et al.	128/218
2,902,035	9/1959	Hartley	604/222
3,314,428	4/1967	Johnson et al.	128/218
3,941,129	3/1976	Pleznac	128/218
4,009,716	3/1977	Cohen	128/218

(List continued on next page.)

FOREIGN PATENT DOCUMENTS

0 515 766 A1	12/1992	European Pat. Off.	A61M 5/50
2 652 006	of 0000	France .	

(List continued on next page.)

OTHER PUBLICATIONS

Supplemental Search Report dated Apr. 19, 1999, issued by European Patent Office in related European Application No. 98105451.3.

Letter dated Mar. 22, 1999 from James E. Bradley to Mr. John Campbell.

Expert Report of George R. Clark cited from Civil Action No. IP 98-1726-C-M/G.

Expert Report of Charles M. Krousgrill, Jr. from in Civil Action No. IP 98-1726-C-M/G.

"The ProtectivTM IV Catheter Safety System," *Modern Healthcare*, Feb. 17, 1992 Manufacturer, Critikon, a Johnson & Johnson Company.

Primary Examiner—John D. Yasko

Attorney, Agent, or Firm—Mitchell G. Stockwell, Esq.;
John S. Pratt, Esq.; Kilpatrick Stockton LLP

[57] ABSTRACT

A syringe apparatus and process for using the same is provided, the syringe apparatus having a barrel, a plunger movable within the barrel, a needle assembly attached to an end of the barrel and having a passageway therethrough, a deformable base positioned within the barrel, flexible supports included on the deformable base, a spring within the passageway of the needle assembly, a hollow needle passing through the passageway, an enlarged head on the needle, and a rupturable web on an end of the plunger, whereby when the plunger moves through the barrel toward the needle assembly, a fluid can be moved from the barrel through the hollow of the needle, and continued movement of the plunger flexes the supports and moves the deformable base downwardly until such time a sufficient force is imparted to the rupturable web by the enlarged head to tear the web, the deformable base then releasing the needle due to force applied by the spring to project the needle into the interior of the plunger. Seals are provided for making a liquid impervious seal on both ends of the syringe after the needle is retracted. The seal on the end left open by needle retraction is a closing member which can be used to seal off the opening without placing a user's hands in front of the opening. The syringe includes indicia that is revealed upon needle retraction to label the syringe as a biohazard. A syringe apparatus using a deformable base, enlarged needle head and needle assembly of an alternative embodiment is also provided wherein sacrificial supports in the needle assembly are utilized and severed by the deformable base.

24 Claims, 17 Drawing Sheets

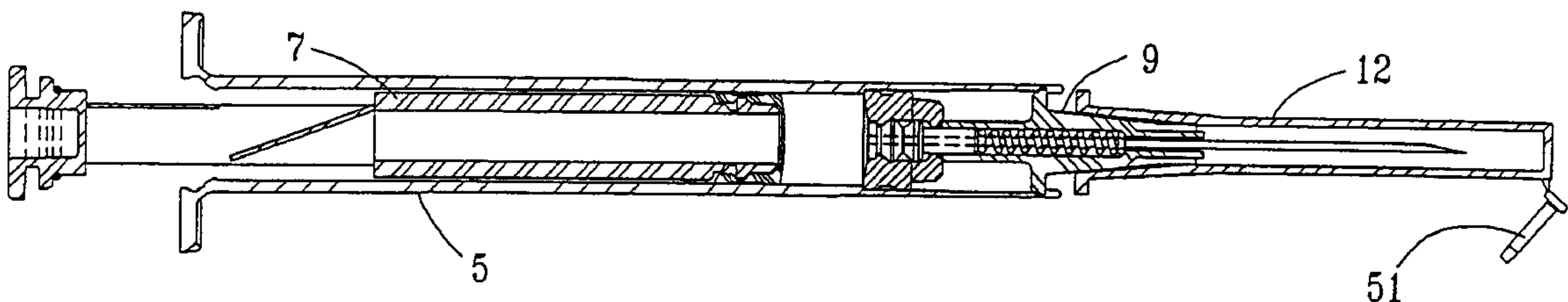

U.S. PATENT DOCUMENTS

4,214,584	7/1980	Smirnov et al.	128/218	5,188,599	2/1993	Botich et al.	604/110
4,316,463	2/1982	Schmitz et al.	128/218	5,188,613	2/1993	Shaw	604/195
4,333,456	6/1982	Webb	128/218	5,190,526	3/1993	Murray et al.	604/110
4,333,458	6/1982	Margulies et al.	128/218	5,201,710	4/1993	Caselli	604/110
4,507,117	3/1985	Vining et al.	604/196	5,211,628	5/1993	Marshall	604/110
4,687,467	8/1987	Cygielski	604/110	5,211,629	5/1993	Pressly et al. .	
4,692,156	9/1987	Haller	604/195	5,211,630	5/1993	Schmahmann	604/110
4,710,170	12/1987	Haber et al.	604/110	5,215,533	6/1993	Robb	604/222 X
4,747,831	5/1988	Kulli	604/110	5,221,262	6/1993	Kite	604/110
4,808,169	2/1989	Haber et al.	604/195	5,242,402	9/1993	Chen	604/110
4,826,484	5/1989	Haber et al.	604/110	5,242,405	9/1993	Howe	604/125
4,838,863	6/1989	Allard et al.	604/110	5,259,840	11/1993	Boris	604/218 X
4,838,869	6/1989	Allard	604/195	5,267,961	12/1993	Shaw	604/110
4,850,968	7/1989	Ramano	604/110	5,300,030	4/1994	Crossman et al.	604/136
4,908,022	3/1990	Haber	604/195	5,324,265	6/1994	Murray et al.	604/110
4,915,692	4/1990	Verlier	604/110	5,342,308	8/1994	Boschetti	604/110
4,921,486	5/1990	DeChellis et al.	604/110	5,342,310	8/1994	Ueyama et al.	604/110
4,927,414	5/1990	Kulli	604/110	5,376,075	12/1994	Haughton et al.	604/158
4,947,863	8/1990	Harber et al.	128/764	5,385,551	1/1995	Shaw	604/110
4,973,316	11/1990	Dysarz	604/195	5,389,076	2/1995	Shaw	604/110
4,978,343	12/1990	Dysarz et al.	604/195	5,407,431	4/1995	Botich et al.	604/110
4,994,034	2/1991	Botich et al.	604/110	5,407,436	4/1995	Toft et al.	604/195
4,997,423	3/1991	Okuda et al.	604/230	5,423,758	6/1995	Shaw	604/110
5,000,736	3/1991	Kaufhold, Jr. et al.	604/110	5,578,011	11/1996	Shaw	604/110
5,007,903	4/1991	Ellard	604/195	5,613,952	3/1997	Pressly, Sr. et al. .	
5,019,044	5/1991	Tsao	604/110	5,782,804	7/1998	McMahon	604/110
5,026,354	6/1991	Kocses	604/195	5,800,403	9/1998	Pressly, Sr. et al. .	
5,049,133	9/1991	Villen Pascual	604/110				
5,053,010	10/1991	McGary et al.	604/110				
5,064,419	11/1991	Gaarde	604/195				
5,084,018	1/1992	Tsao	604/110				
5,098,402	3/1992	Davis	604/195				
5,114,404	5/1992	Paxton	604/110				
5,114,410	5/1992	Caralt Battle	604/195				
5,120,310	6/1992	Shaw	604/110				
5,125,898	6/1992	Kaufhold, Jr. et al.	604/110				
5,180,369	1/1993	Dysarz	604/195 X				
5,180,370	1/1993	Gillespie	604/110				

FOREIGN PATENT DOCUMENTS

2197 792	6/1988	United Kingdom	A61M 5/315
WO 92/21396	of 0000	WIPO .	
WO 93/12830	of 0000	WIPO .	
WO 89/00435	1/1989	WIPO	A61M 5/28
WO 90/03196	4/1990	WIPO	A61M 5/32
WO 90/06146	6/1990	WIPO	A61M 5/32
WO 90/07948	7/1990	WIPO	A61M 5/50
WO 91/04066	4/1991	WIPO	A61M 5/50
WO 96/05879	2/1996	WIPO	A61M 5/32

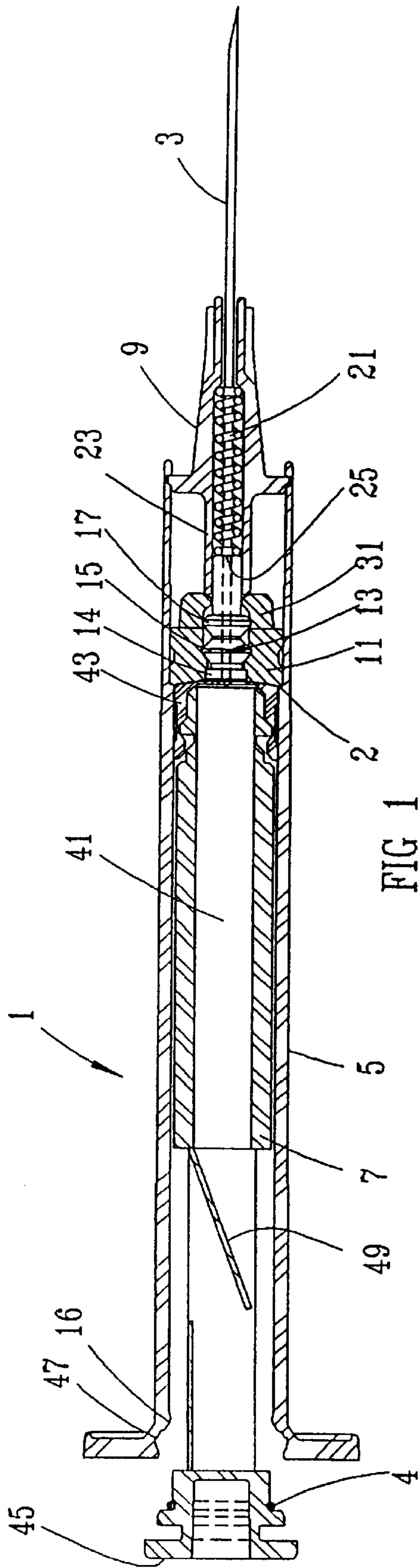

FIG 1

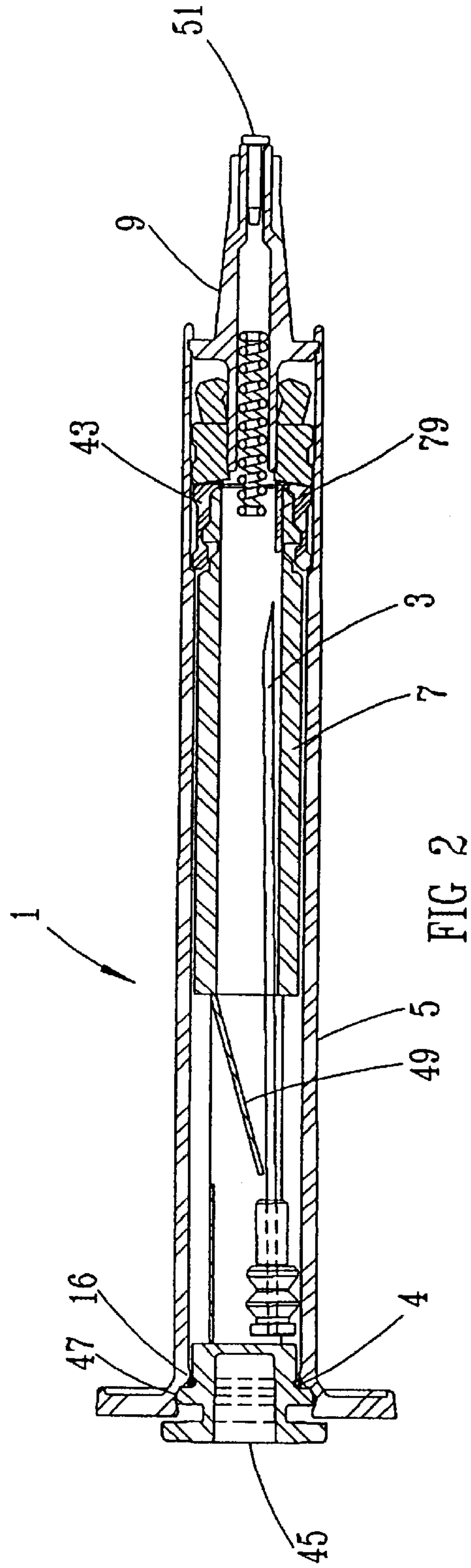
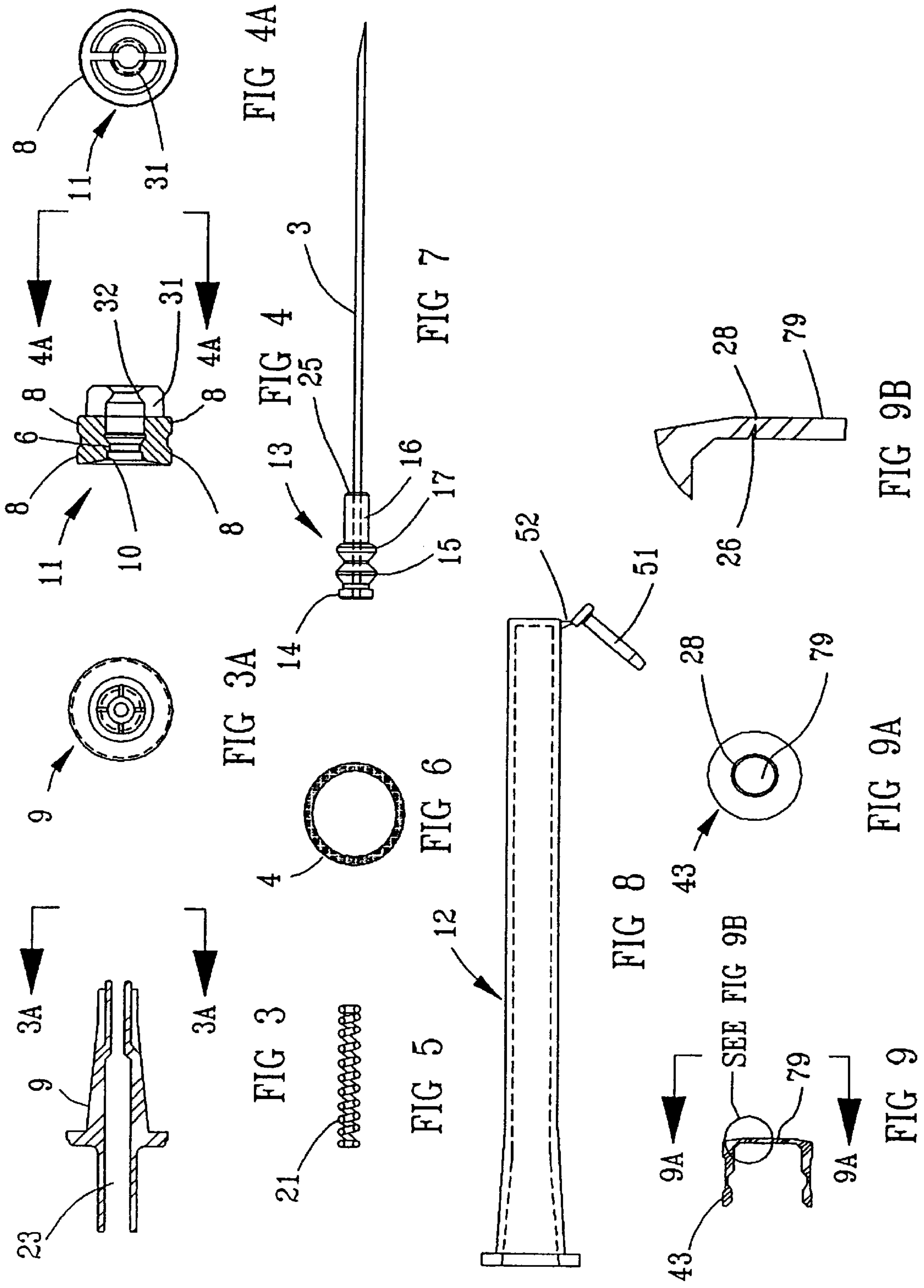

FIG 2



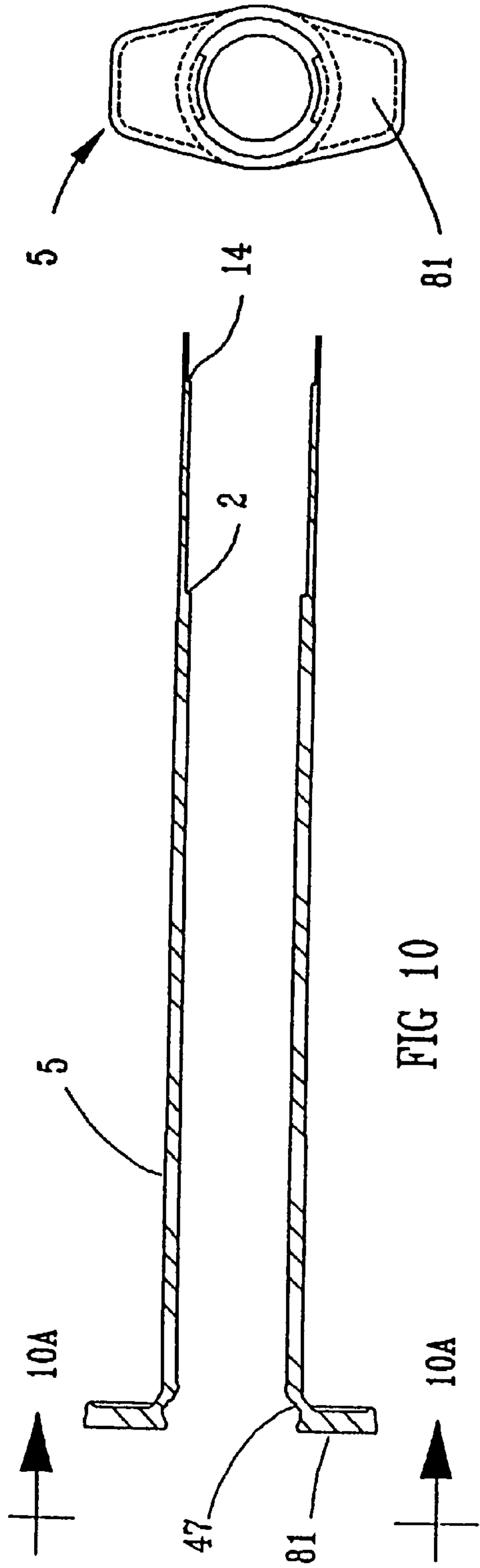

FIG 10A

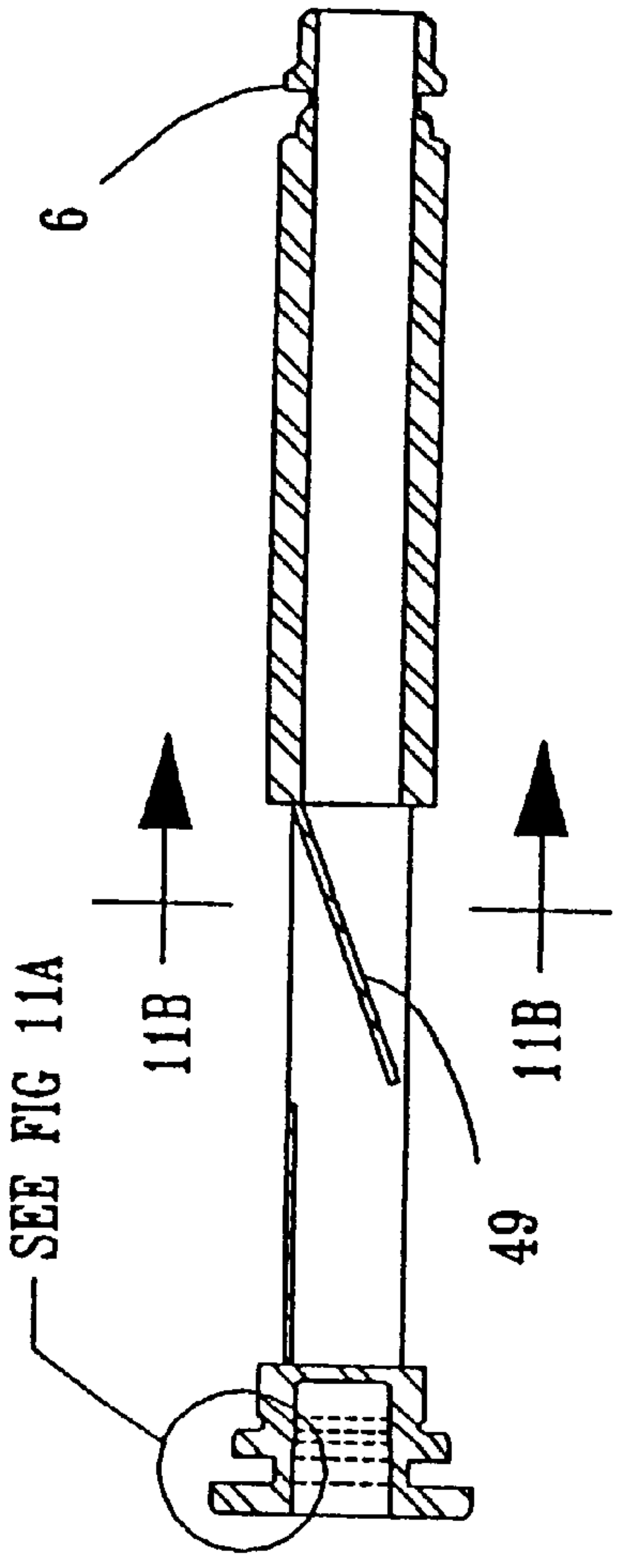
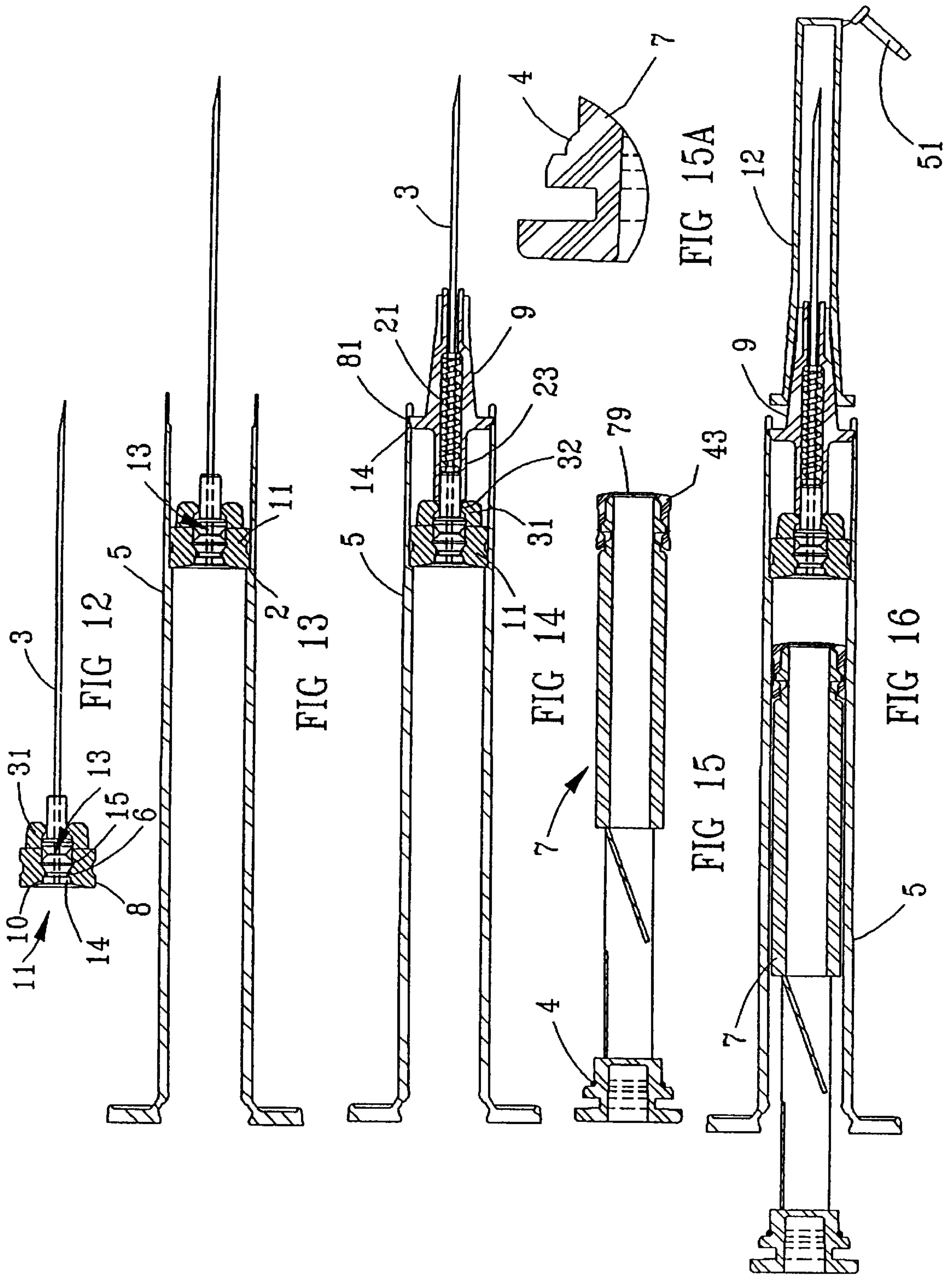

FIG 11A

FIG 11B



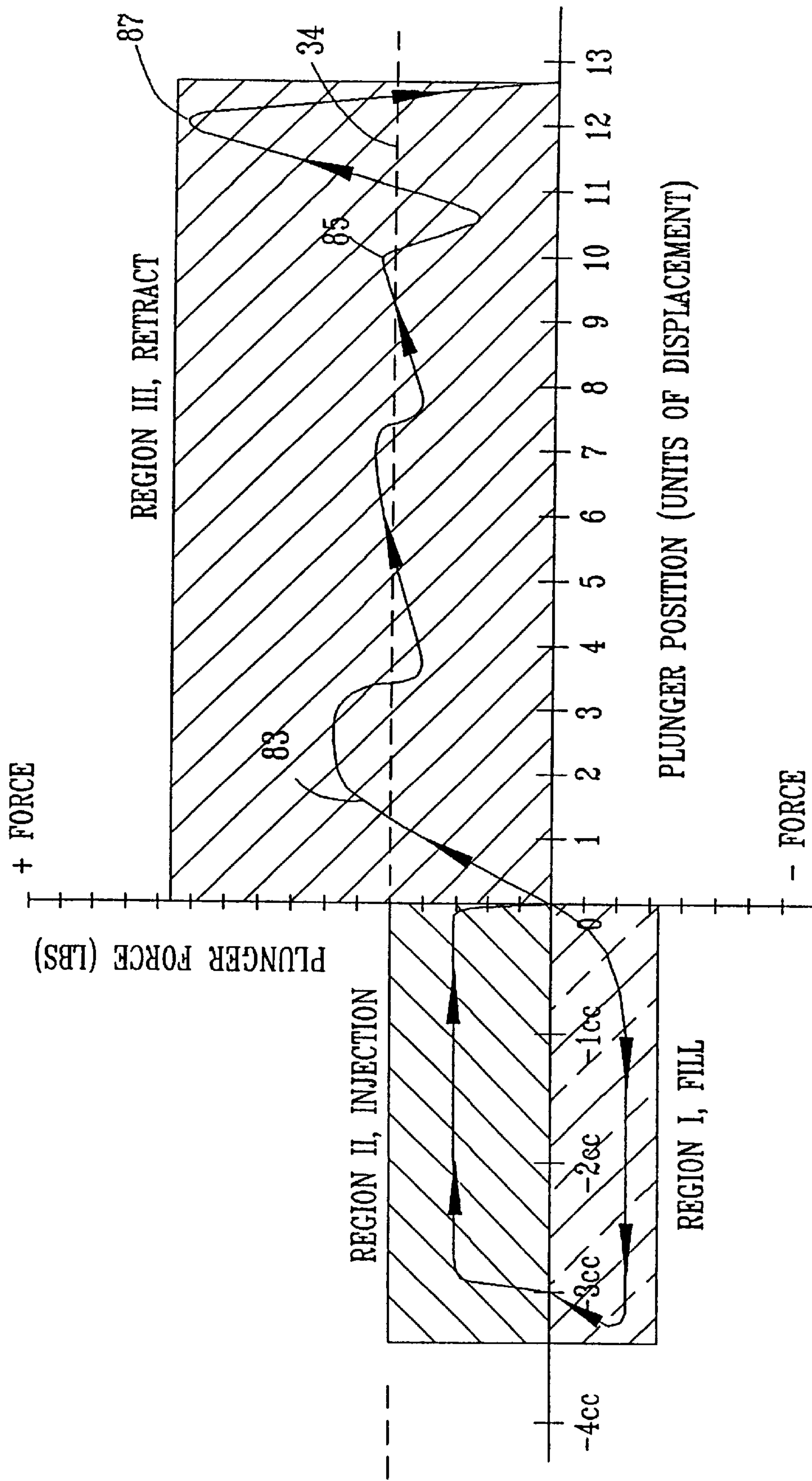
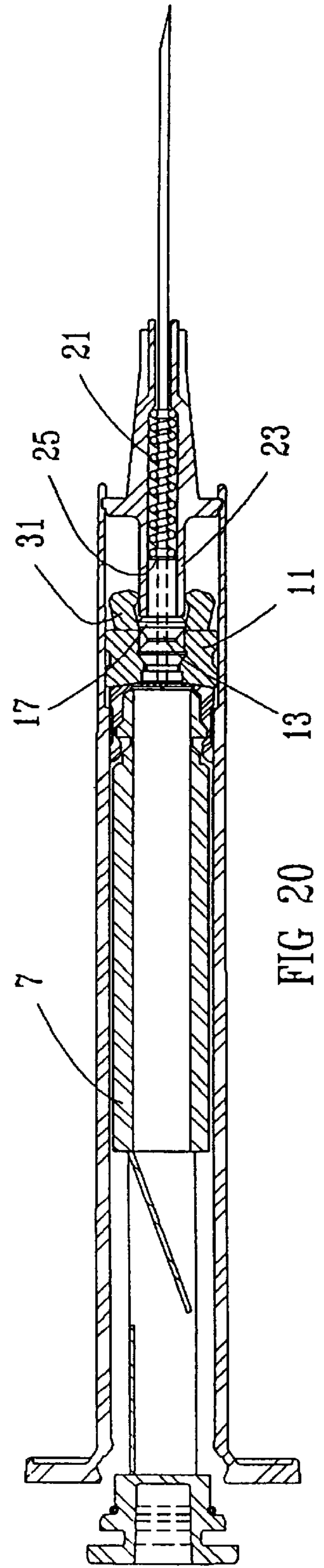
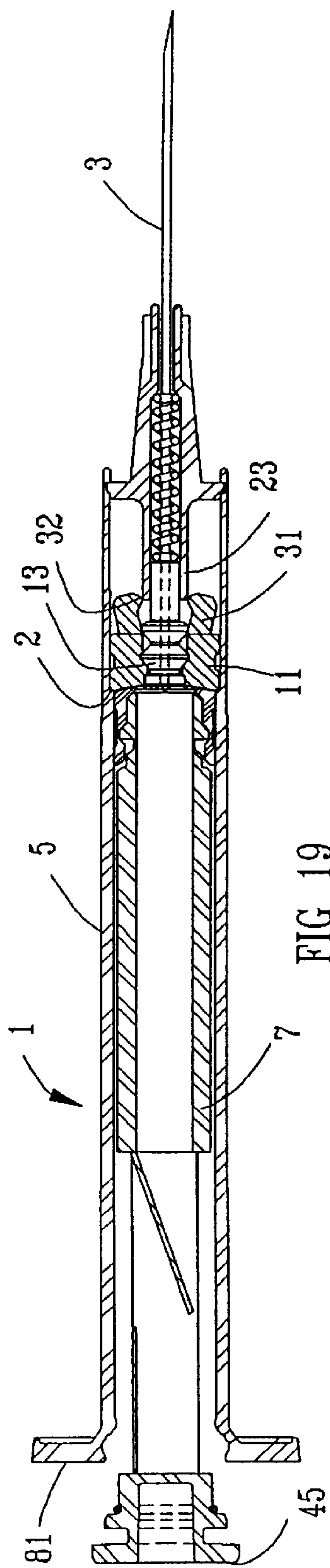
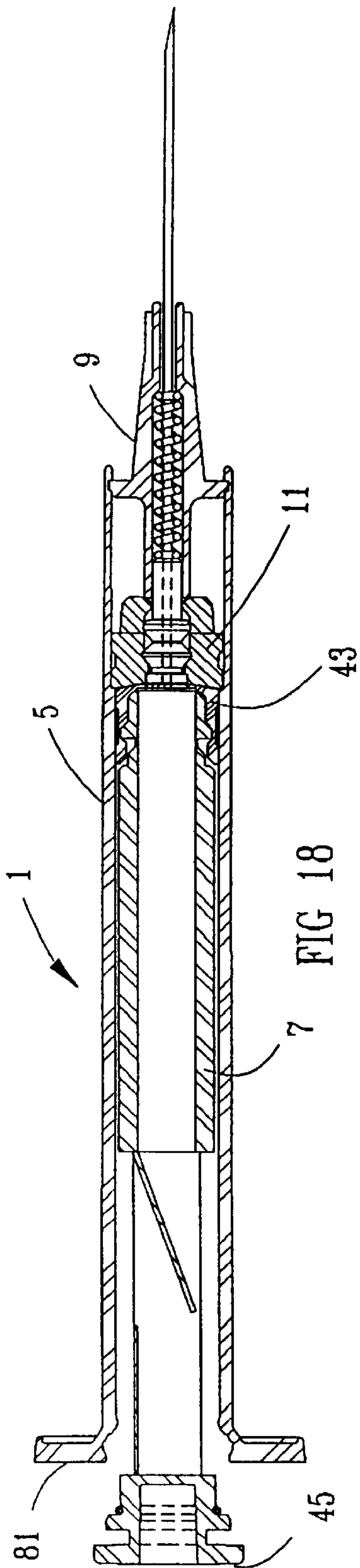
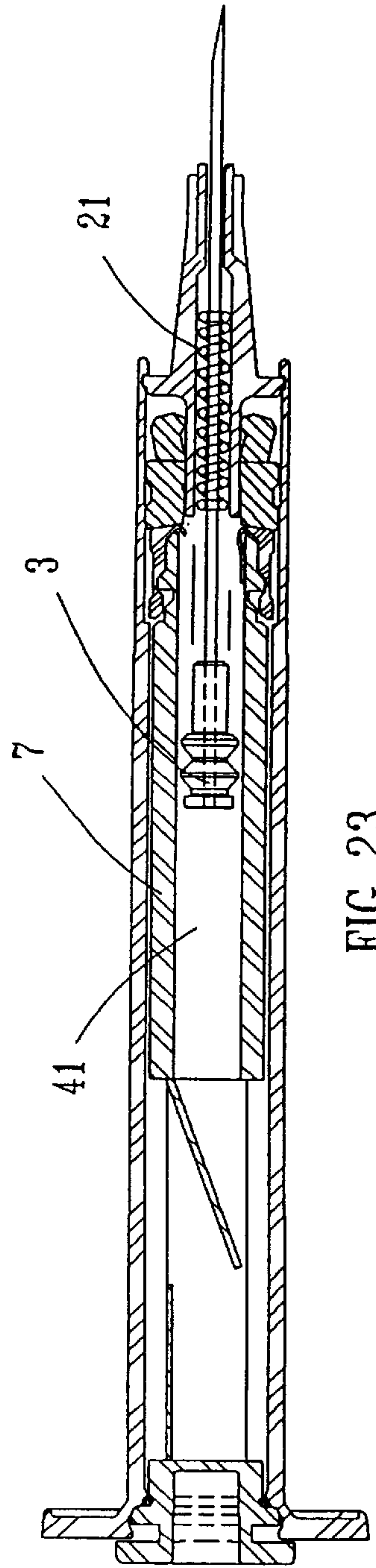
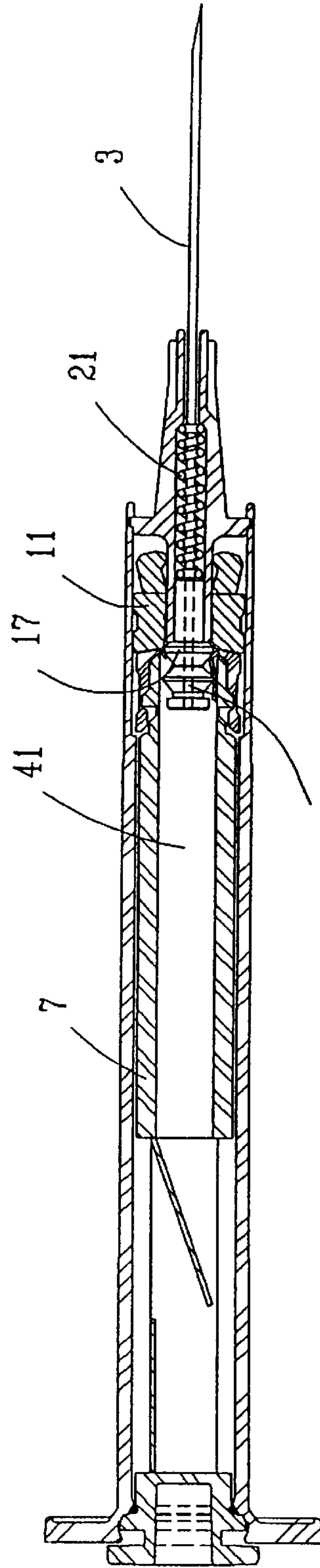
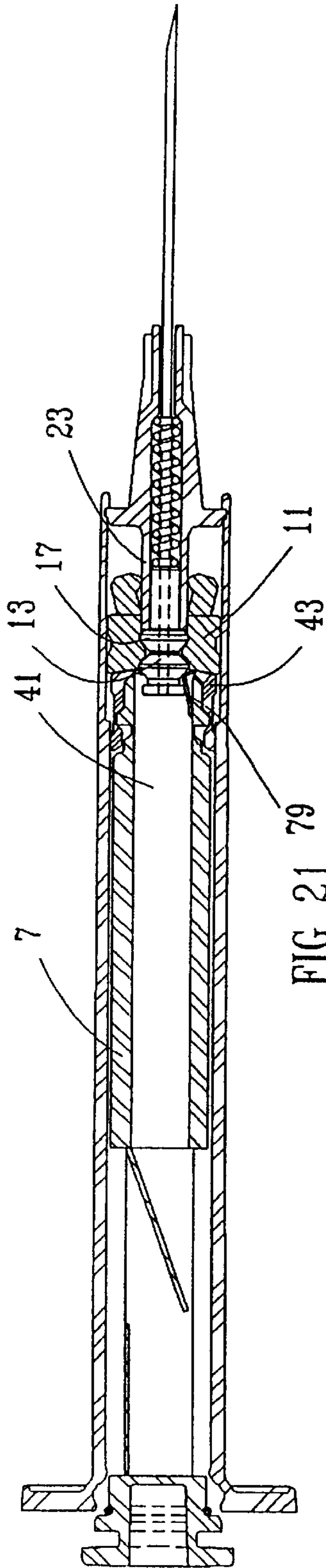
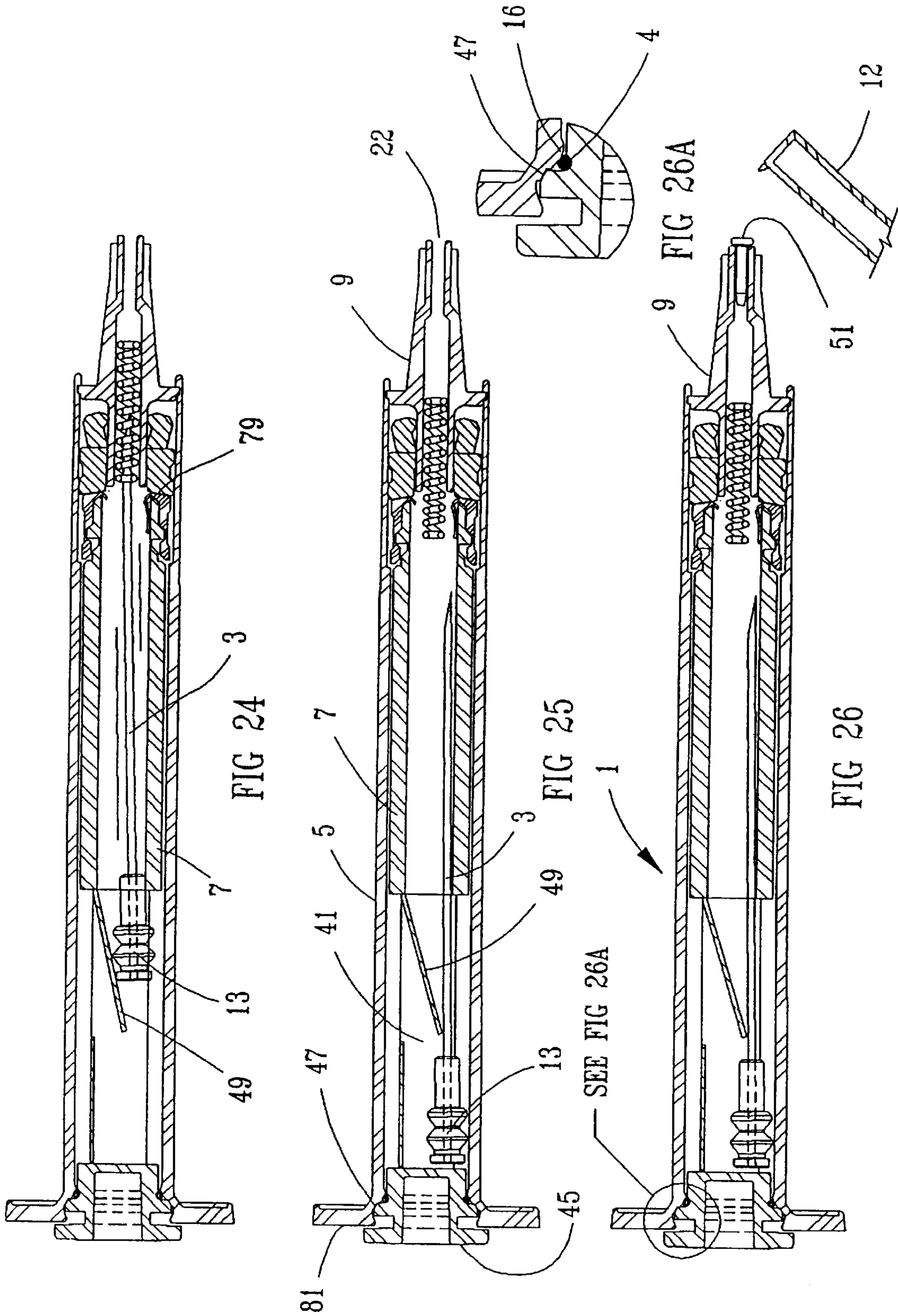

FIG 17







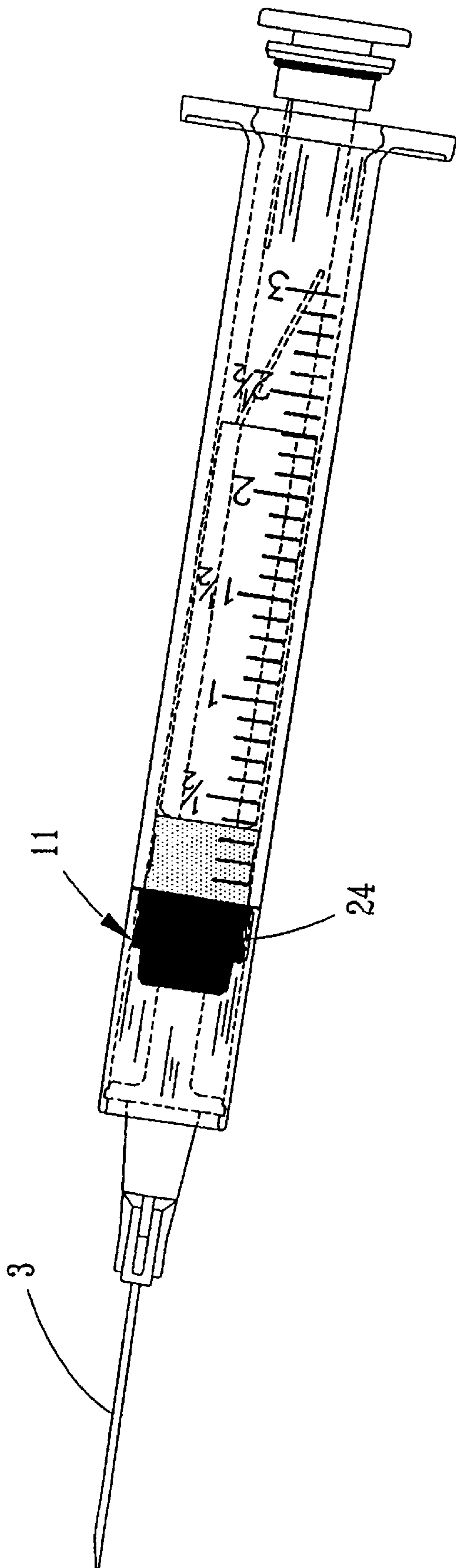

FIG 27

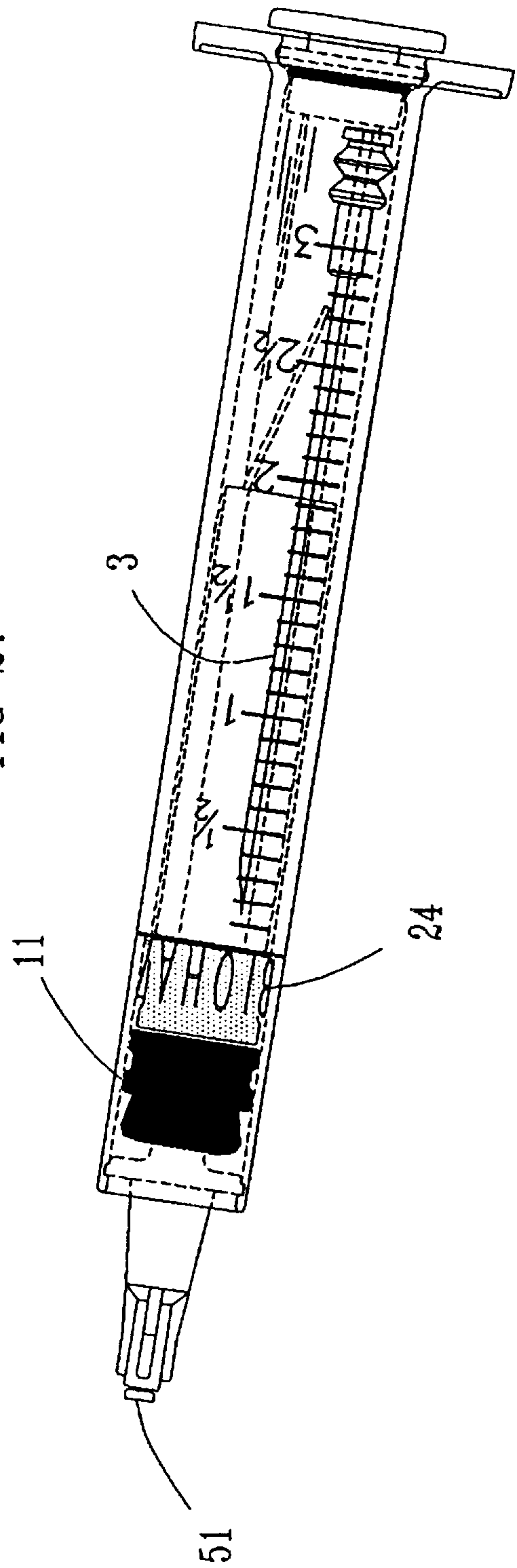
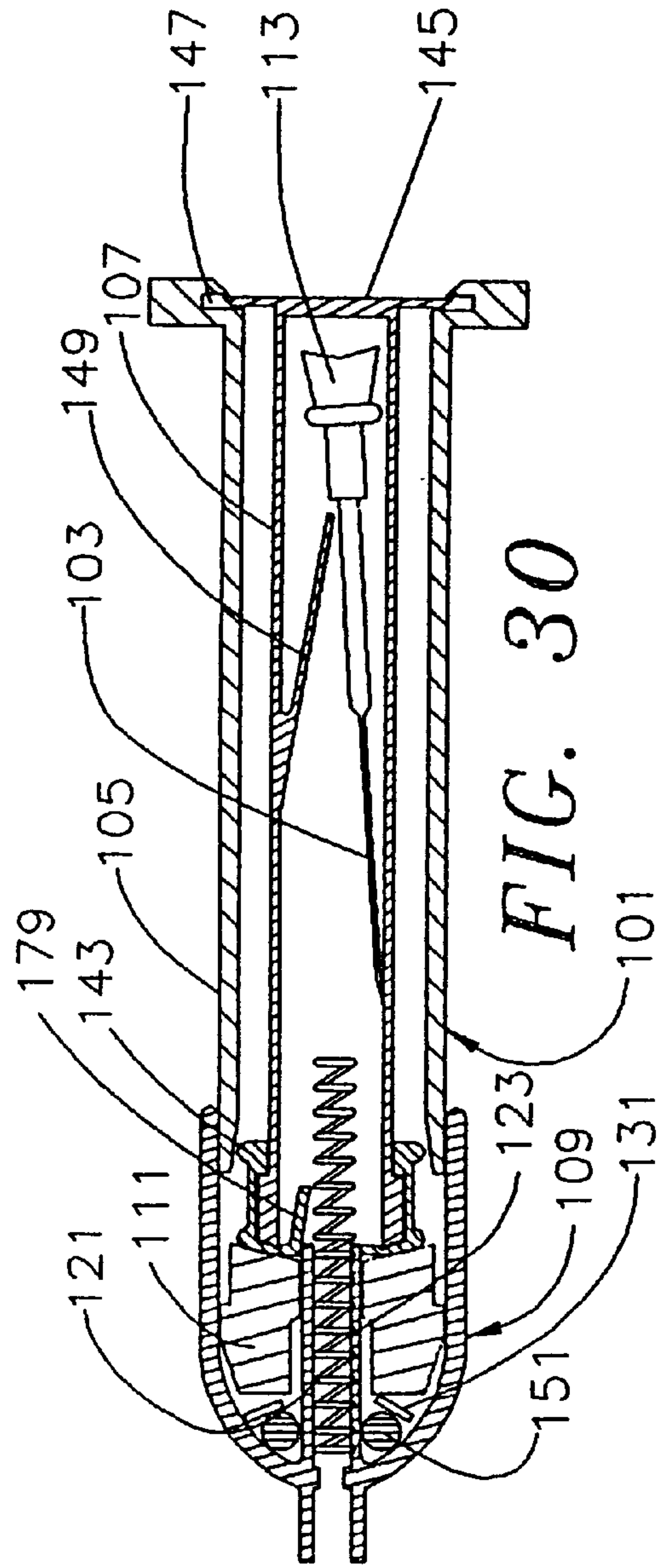
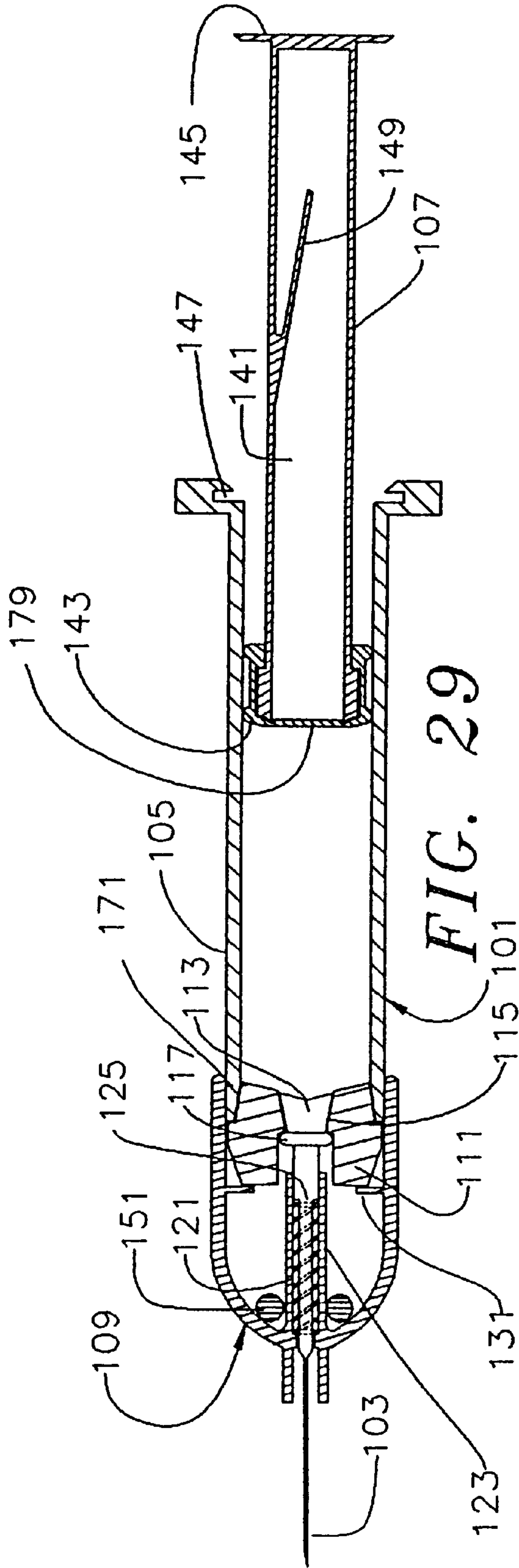

FIG 28



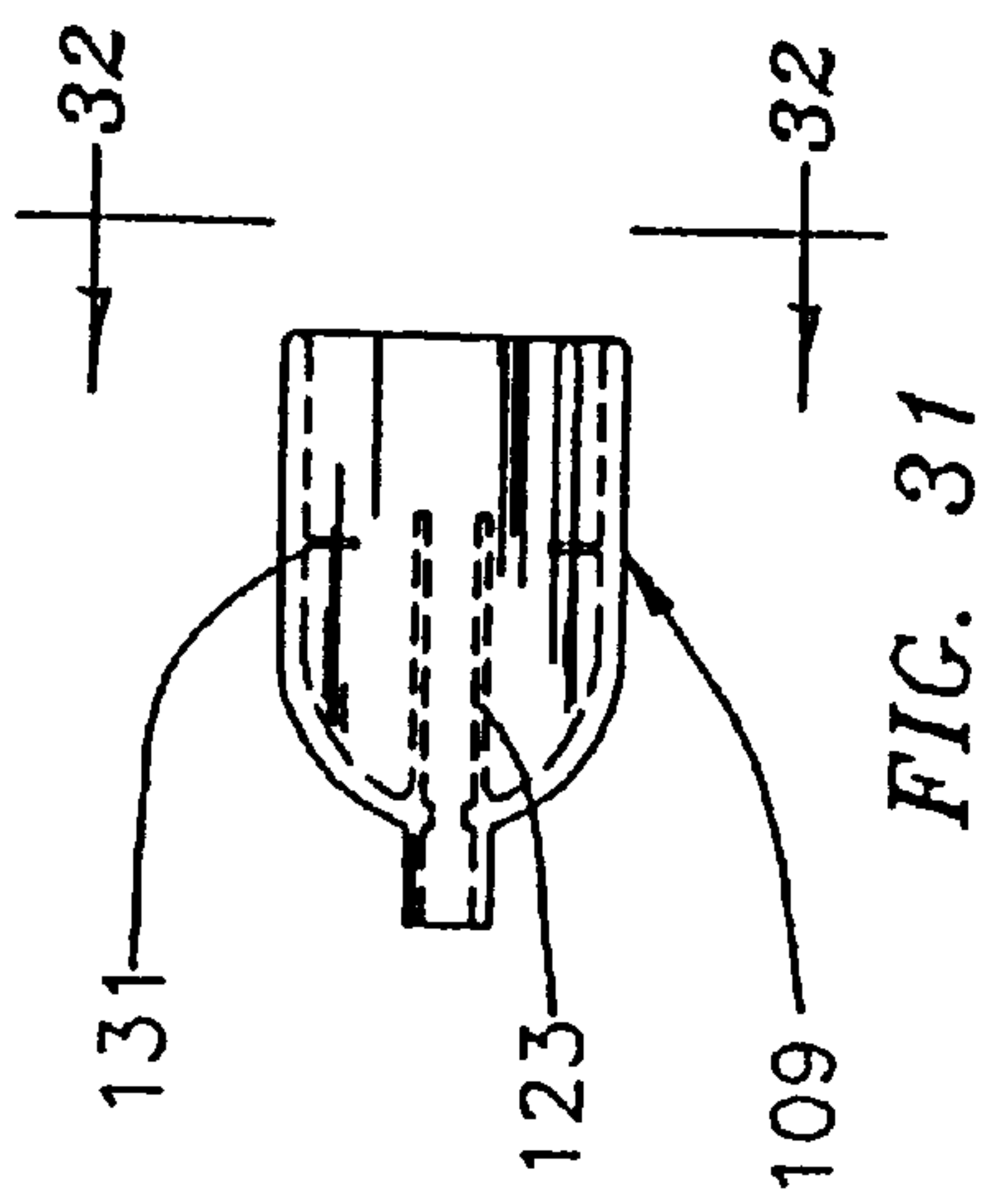
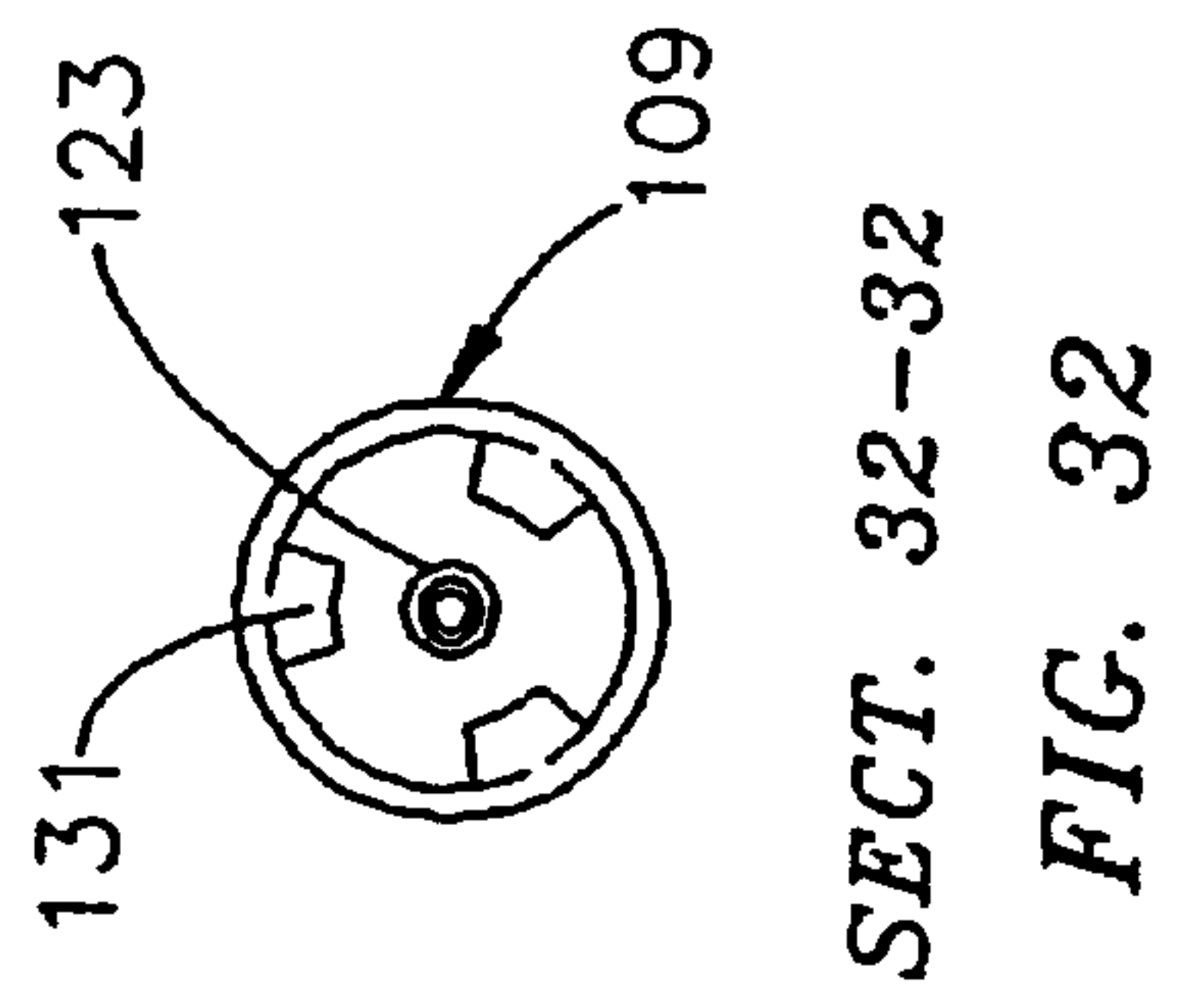

FIG. 31



SECT. 32-32
FIG. 32

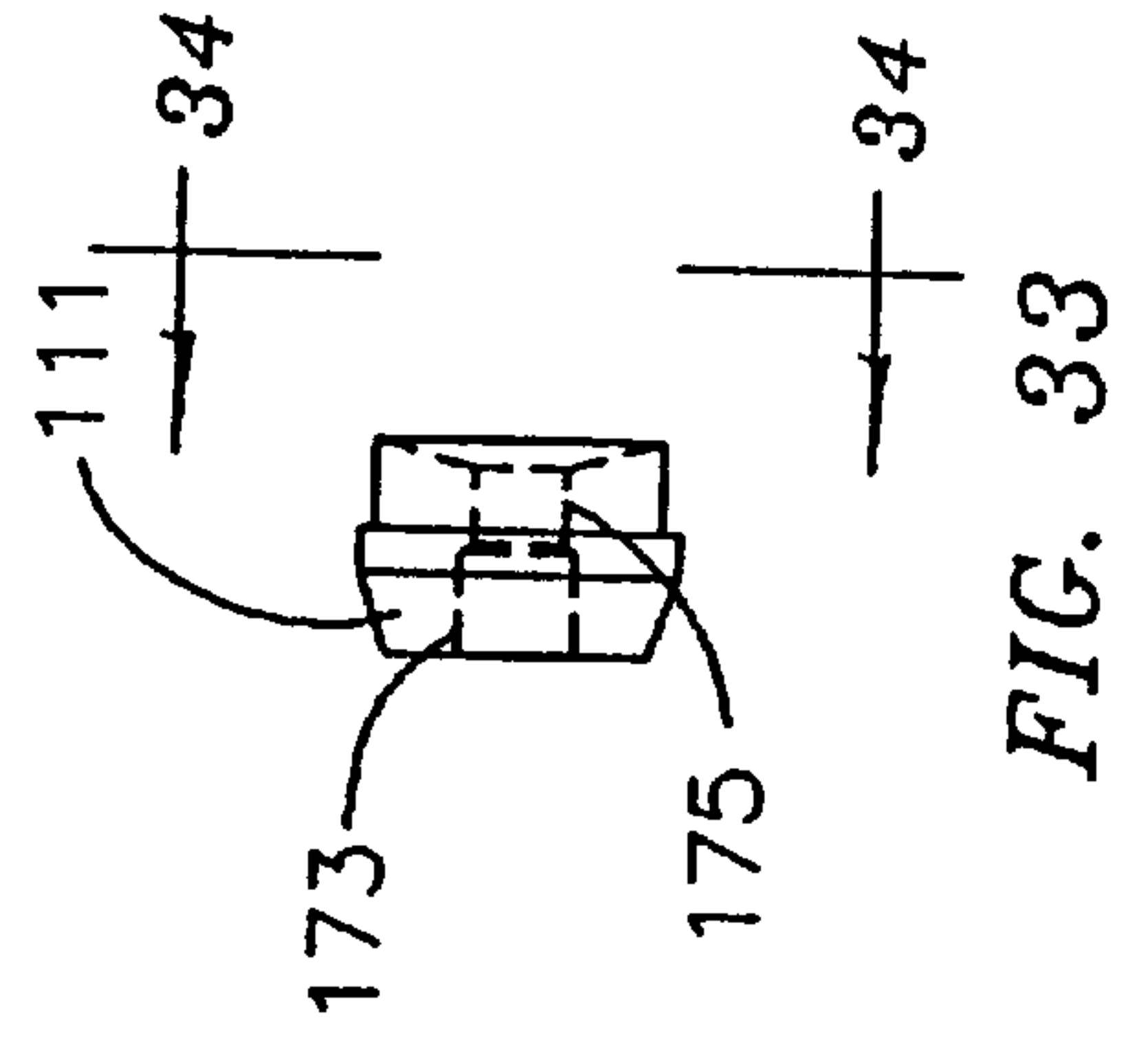
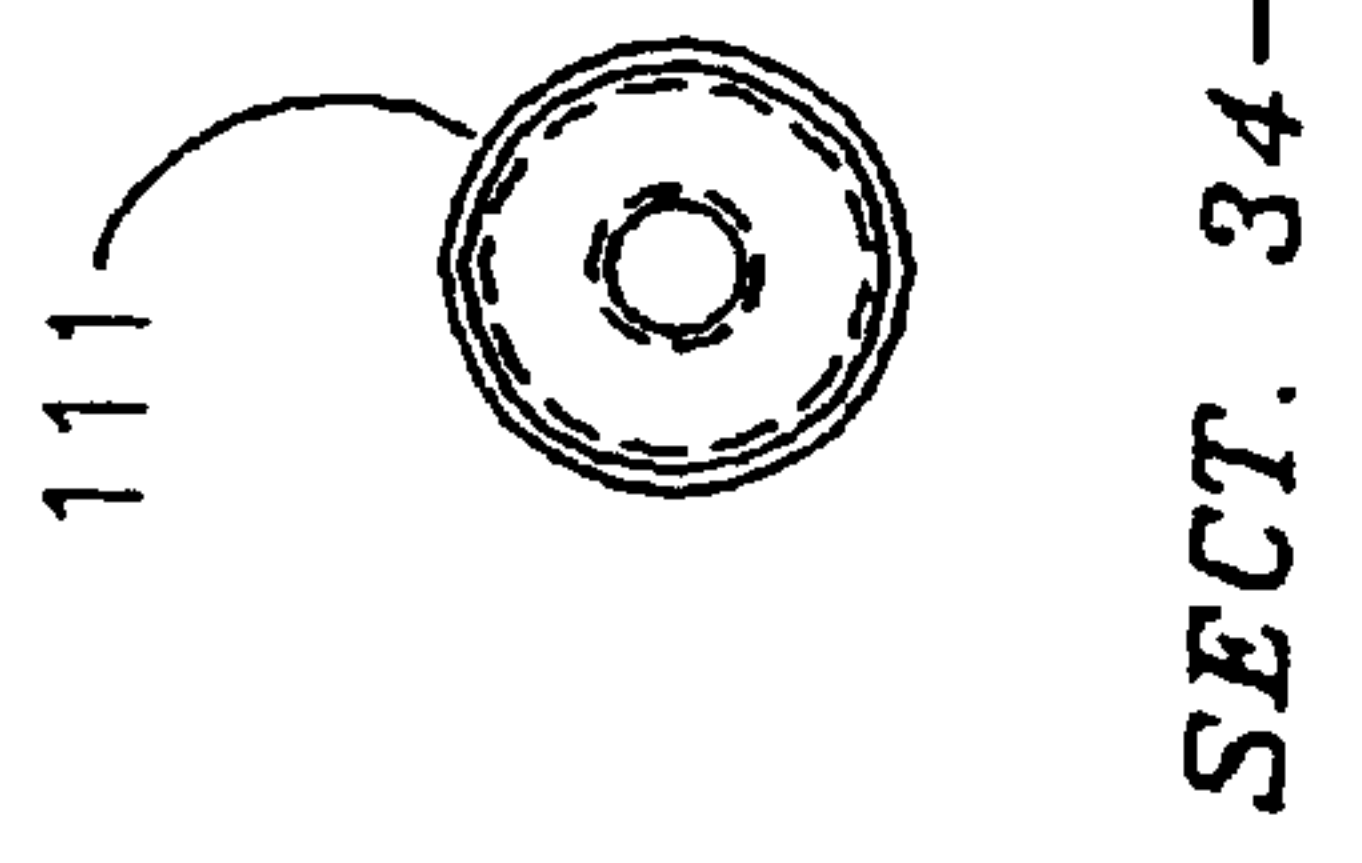

FIG. 33



SECT. 34-34
FIG. 34

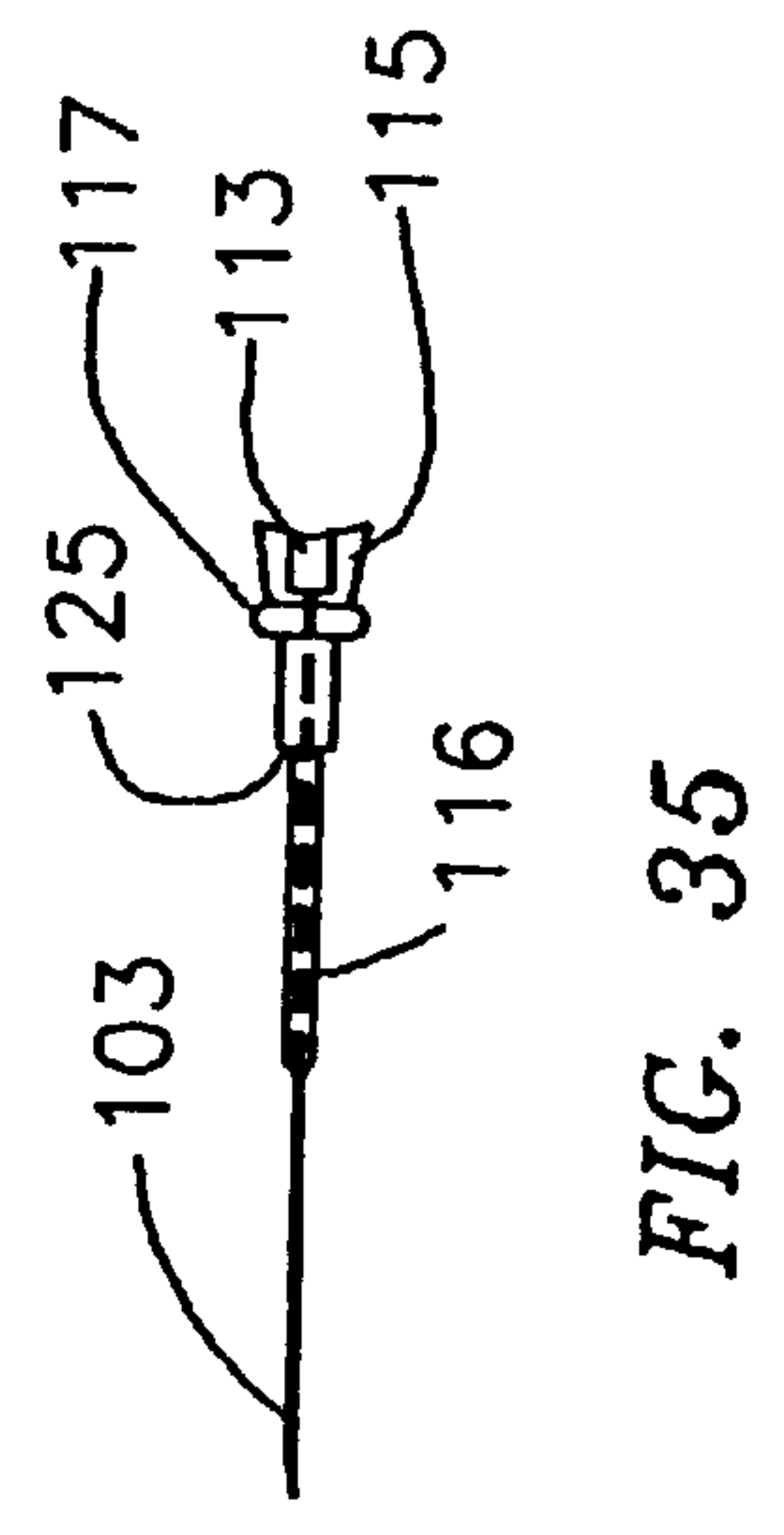

FIG. 35

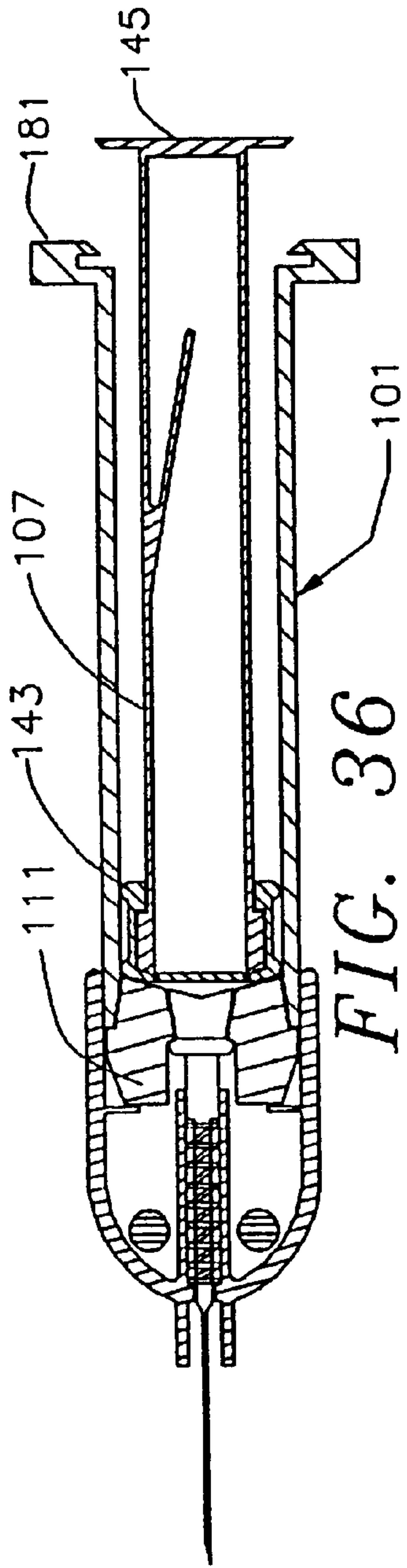

FIG. 36

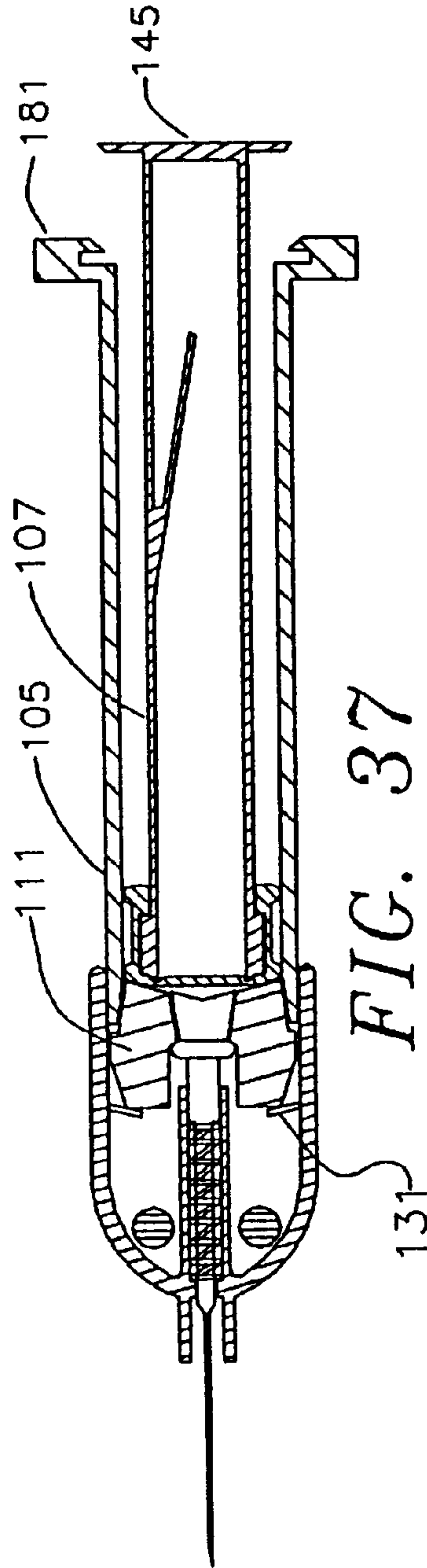

FIG. 37

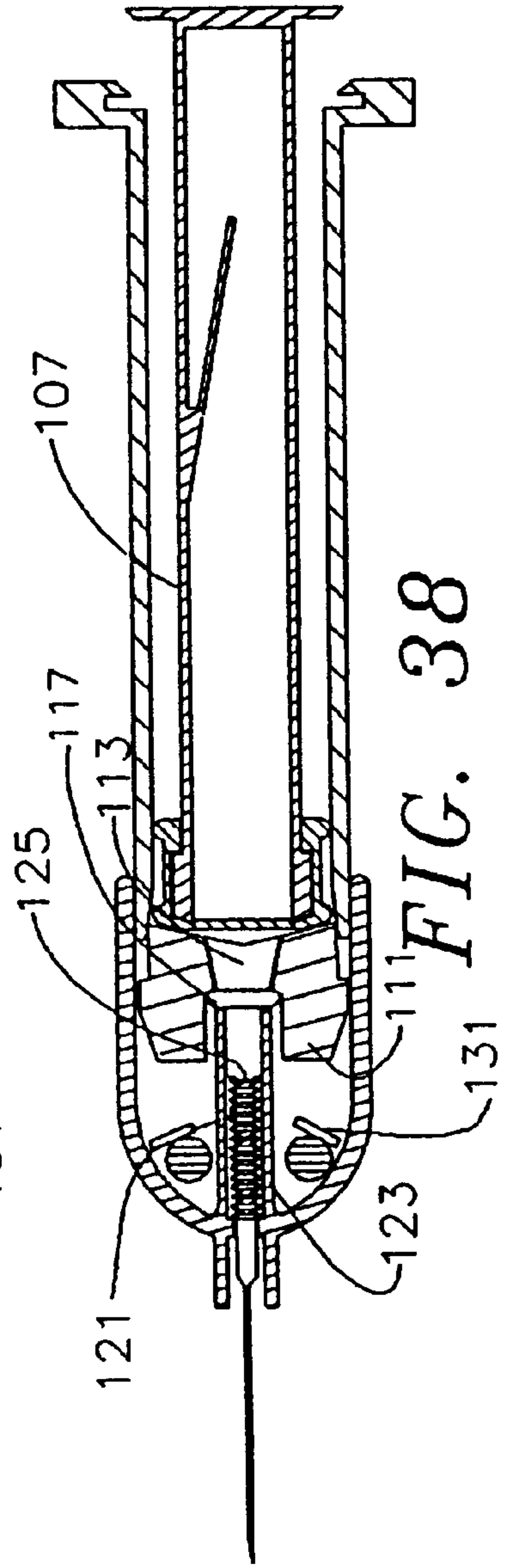
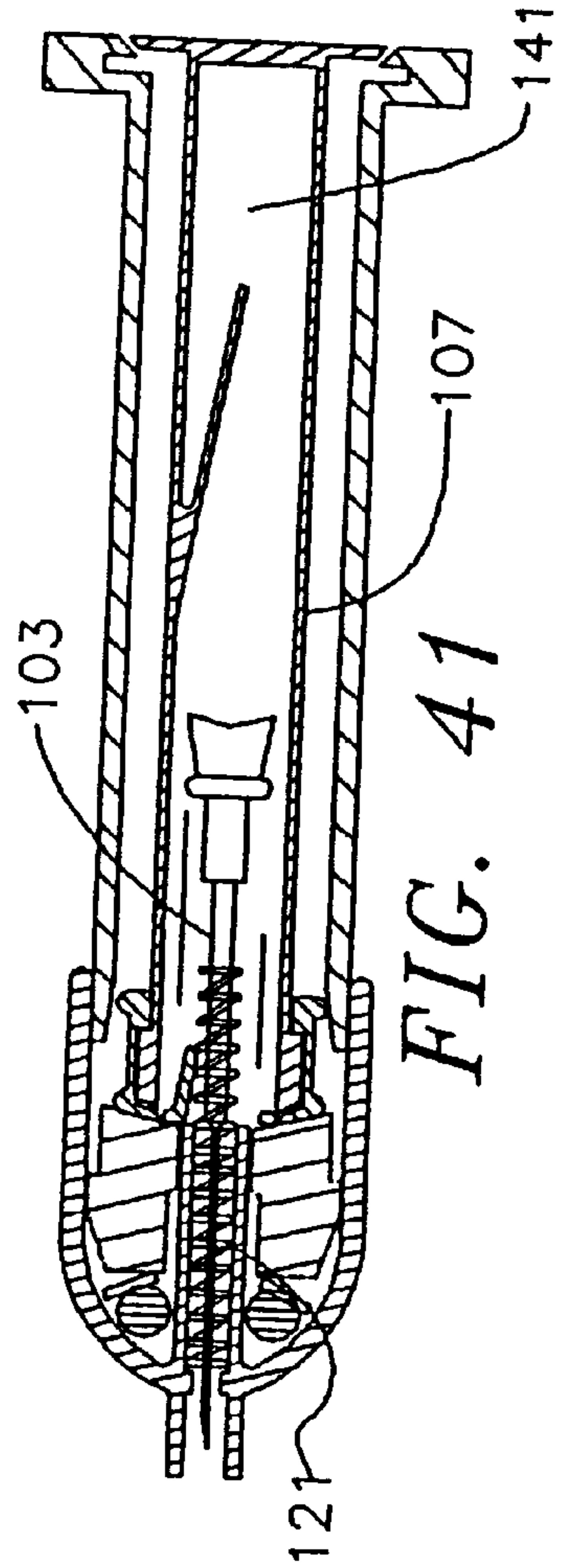
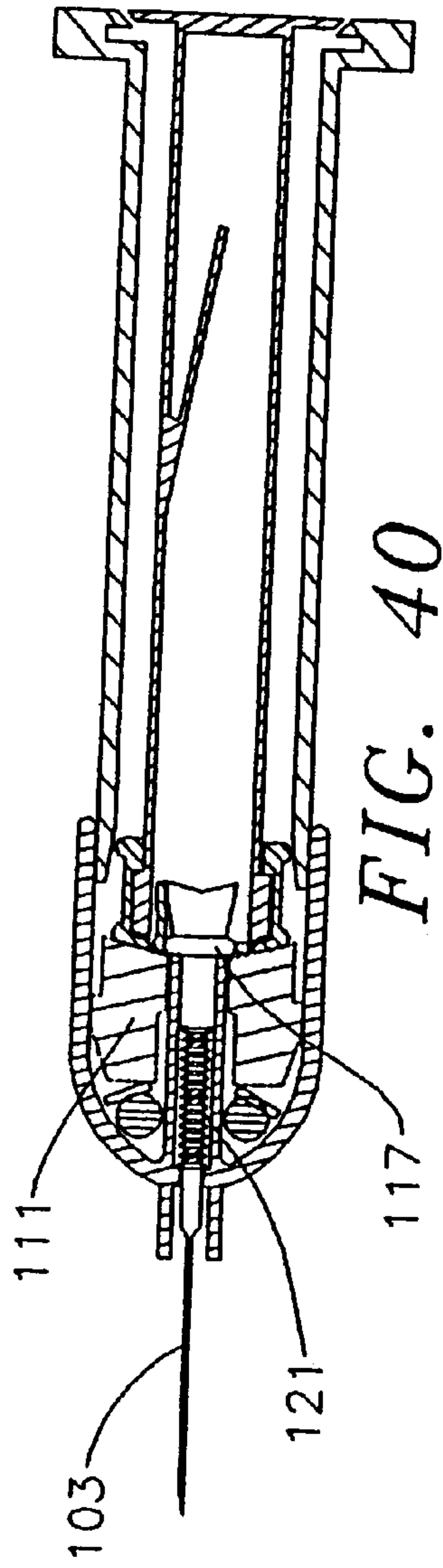
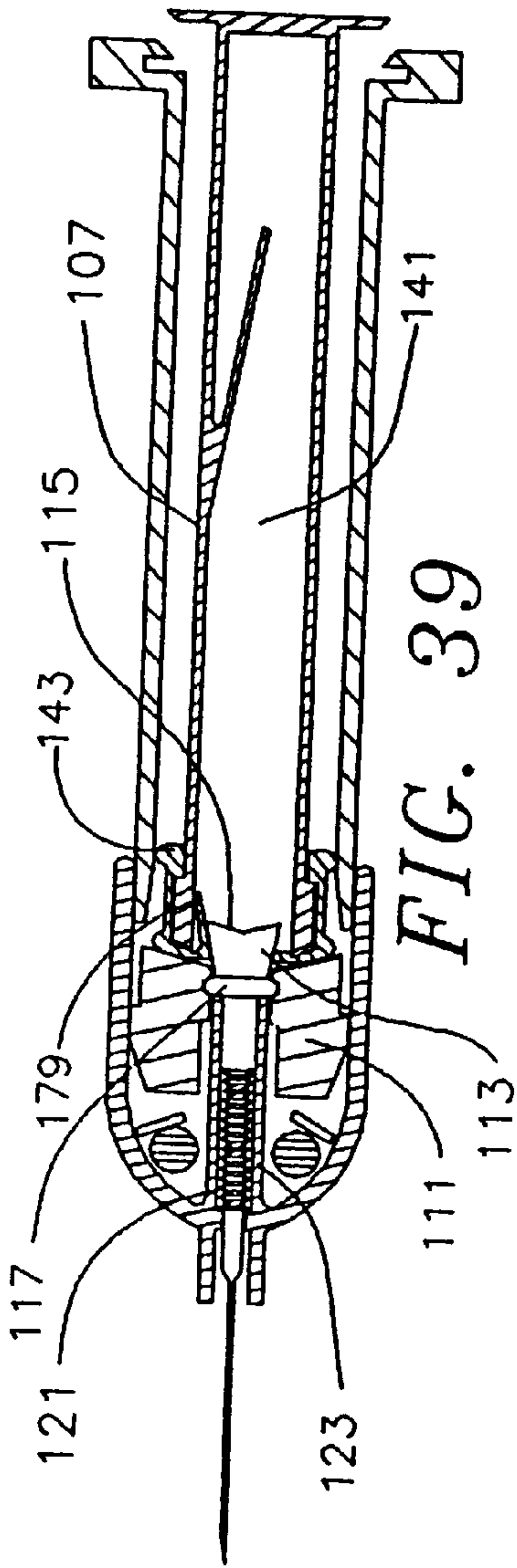

FIG. 38



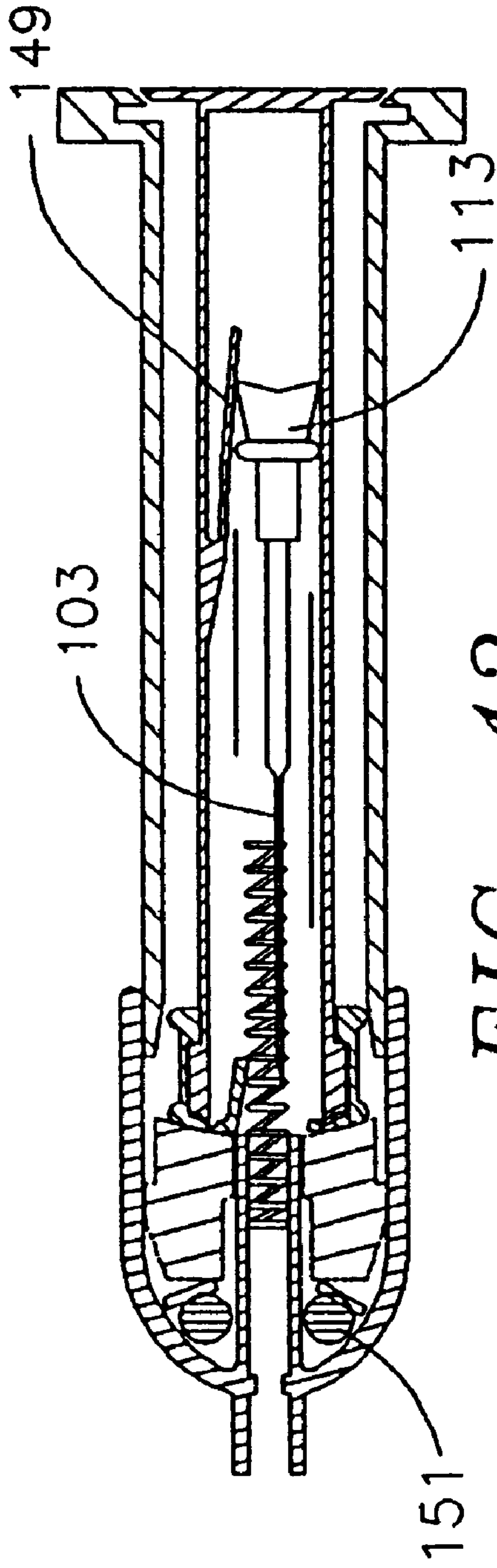

FIG. 42

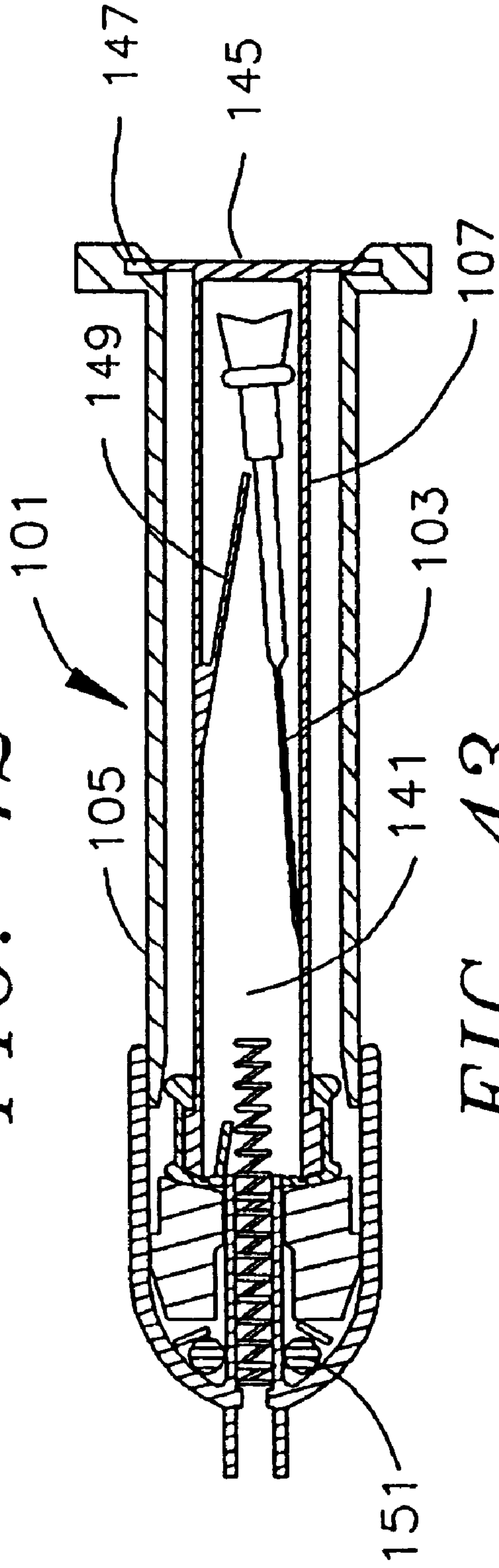

FIG. 43

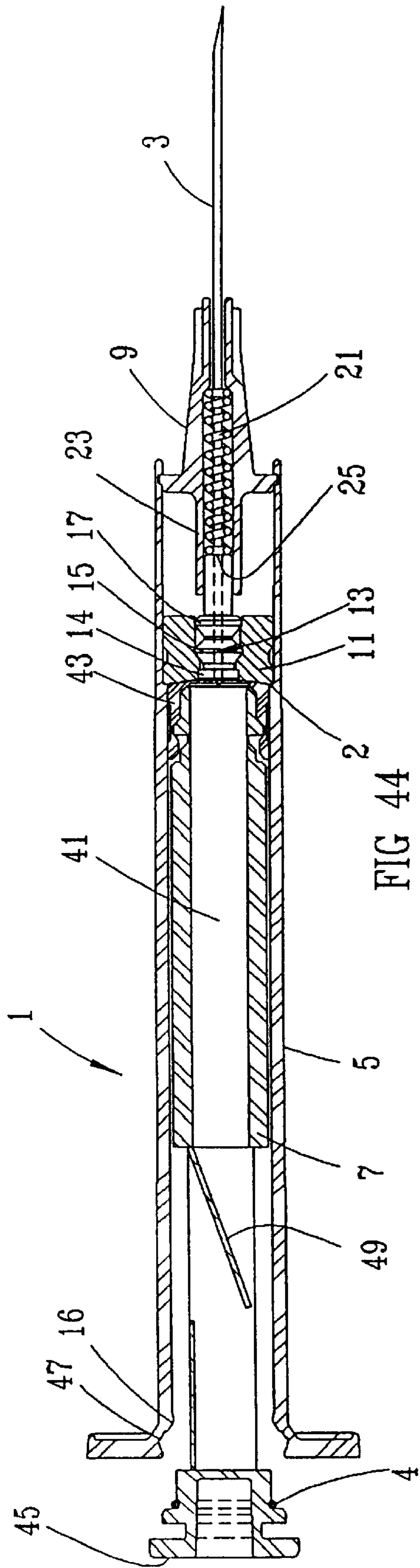

FIG 44

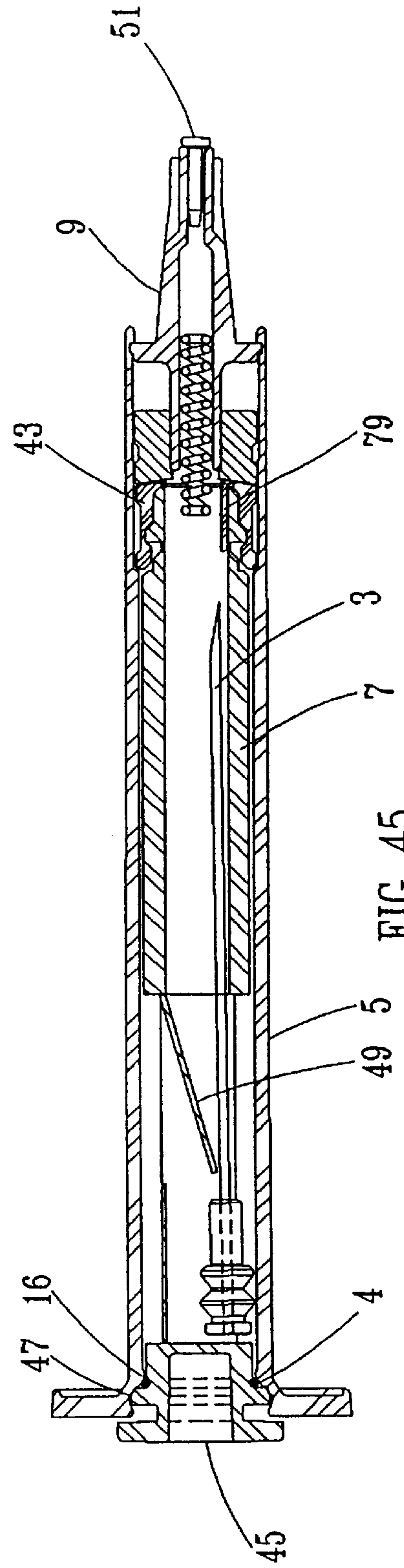
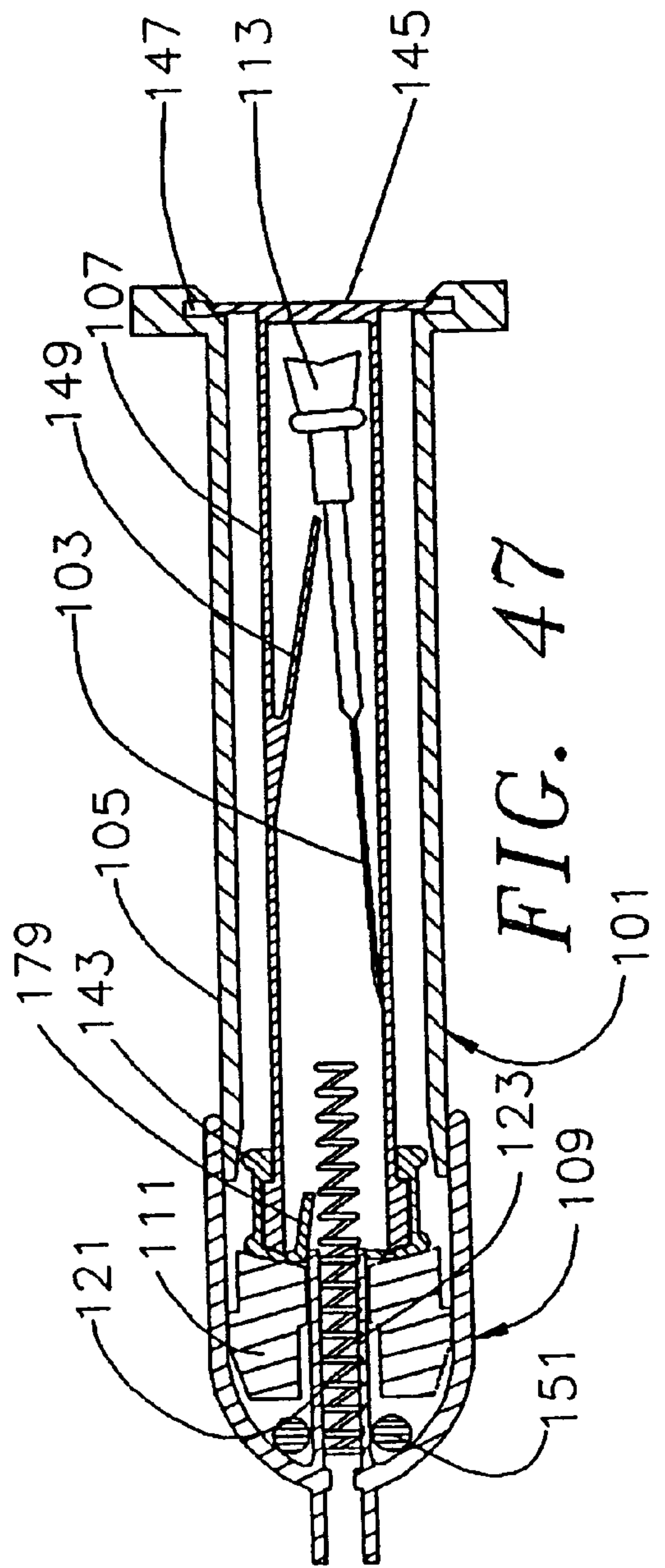
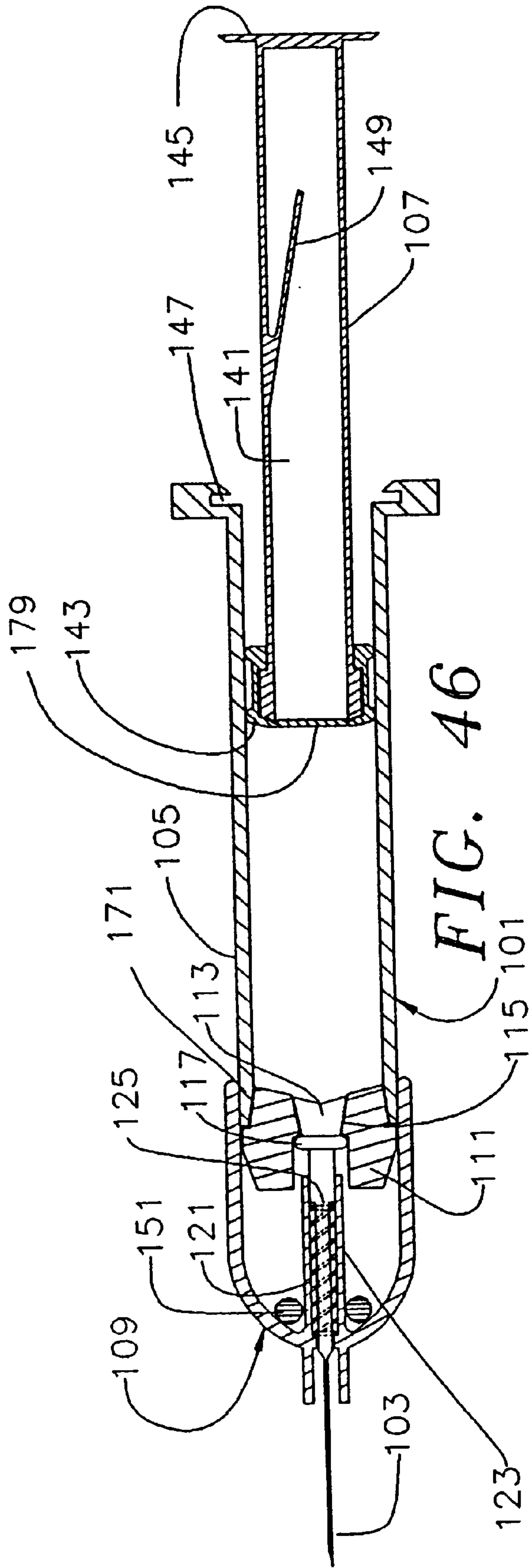

FIG 45



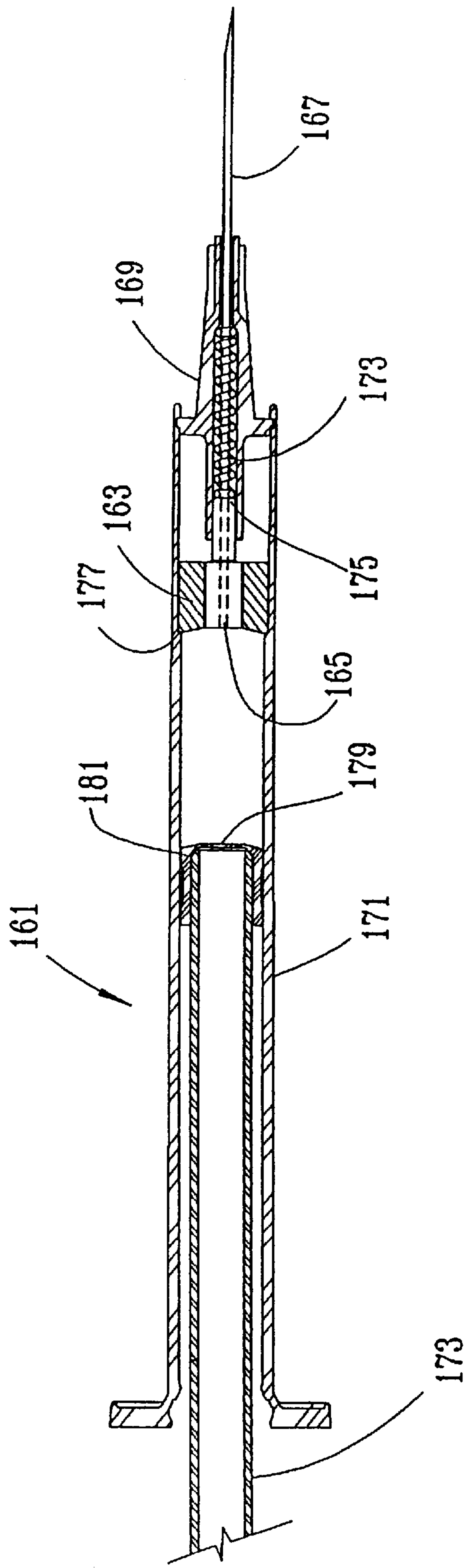

FIG 48

SAFETY SYRINGE

CROSS REFERENCE TO RELATED APPLICATIONS

This application is a continuation of U.S. application Ser. No. 08/783,665, filed Jan. 15, 1997, (now U.S. Pat. No. 5,800,403), which is a continuation of U.S. application Ser. No. 08/481,093, filed Jun. 7, 1995, (now U.S. Pat. No. 5,613,952), which is a continuation-in-part of U.S. application Ser. No. 08/359,001, filed on Dec. 16, 1994, abandoned, which is a continuation of U.S. application Ser. No. 08/813,115, which was filed on Dec. 23, 1991 (now U.S. Pat. No. 5,211,629).

BACKGROUND OF THE INVENTION

This invention relates generally to the art of syringes and more particularly to a syringe which reduces the likelihood of unintentional puncture or pricking of human skin. In recent history, the transmission of contagious diseases, particularly those brought about exclusively by the co-mingling of human body fluids, has been of great technological interest. One of the particular problems has been associated with the use and disposal of hypodermic syringes, particularly among healthcare professionals. There have been various devices developed for the destruction of the needles or cannula used in such syringes. Additional devices have been developed for capping of syringes which attempt to minimize the likelihood of accidental puncture. The accidental puncture or pricking of a finger, or any other part of the body, after the treatment of a patient with a contagious disease, particularly a deadly contagious disease, results in a high likelihood of transmission of that disease. Various syringes have been developed in the prior art to attempt to minimize the likelihood of accidental puncture after patient treatment.

One such device is described in U.S. Pat. No. 4,973,316 to Dysarz wherein a needle is retracted into the barrel of the syringe after the use thereof. Another such device is described in U.S. Pat. No. 4,921,486 to DeChellis, et al. One of the earlier patents in this regard was U.S. Pat. No. 2,460,039 issued to Scherer, et al.

Other references disclosing devices relating to needle retraction in a syringe include U.S. Pat. Nos. 4,994,034 to Botich et al, 4,838,869 to Allard, and 5,114,410 to Battle, GB 2 197 792 to Powers et al., WIPO 90/06146 to Nacci et al., and WIPO 90/03196 to Utterberg et al. While all such devices seek the same goal of preventing accidental puncture, considerable room for improvement exists.

SUMMARY OF THE INVENTION

It is thus an object of this invention to provide a novel hypodermic syringe which minimizes the likelihood of accidental puncture.

It is a further object of this invention to provide such a syringe which, after utilization, isolates the used needle so as to render such needle harmless, and automatically indicates that the syringe represents a biohazard.

It is a further and more particular object of this invention to provide such a hypodermic syringe which is operable utilizing only one hand.

It is a further and yet more particular object of this invention to provide such a syringe which automatically, upon the end of an injection, retracts its needle to prevent its reuse, while sealing the needle within the body of the syringe to prevent leakage of residual fluids.

It is a further object of the invention to provide a simple device, which is manufacturable in high volumes.

These as well as other objects are accomplished by a hypodermic syringe having a barrel with a plunger movable therein to inject a fluid through a hollow needle thereof. A hollow needle is housed in a passageway within a needle assembly. Positioned between the passageway within the needle assembly and a shelf on an internal wall of the syringe barrel is a deformable base, with integral flexible supports. The deformable base forms a liquid tight seal with the barrel, at the needle end of the barrel. The deformable base houses an enlarged head of the needle which enlarged head is in contact with energy storage means within the passageway in the needle assembly. The plunger has a thin, rupturable web on an end thereof which is part of a boot covering the end of the plunger, the boot, including the web, being liquid impermeable for forcing a liquid from the barrel upon movement of the plunger. Upon completion of an injection, the boot-covered plunger contacts the deformable base, and upon application of force at the plunger, moves such base downward. Continued application of force causes the flexible supports to flex and move over the needle assembly, permitting the deformable base to move the enlarged head of the needle downward until further movement of the enlarged head is blocked by the needle assembly. With the enlarged needle head blocked by the needle assembly, continued force at the plunger causes the deformable base to move around the enlarged needle head. As the deformable base moves around the needle assembly, the enlarged needle head begins to protrude from the deformable base and come into contact with the web on the boot of the plunger. Continued force causes the enlarged needle head to tear the web of the boot, positioning the enlarged needle head just inside a hollow portion of the plunger. The torn portion of the web creates a flap just inside the hollow plunger. As the plunger moves the deformable base still further, the enlarged needle head loses contact with the deformable base, which triggers a release of energy from the energy storage means in the passageway, projecting the needle with its enlarged head into the hollow portion of the plunger. Once inside the plunger, the needle is trapped by its enlarged head behind a flexible catch within the plunger. Final movement of the plunger causes the plunger to become substantially locked in the barrel and causes a liquid tight seal to be created between the plunger and the syringe body. A closing member placed on the front of the needle assembly completely seals the syringe to prevent residual fluids from escaping. Completion of the needle retraction also automatically highlights an indicia such as a biohazard label which alerts persons handling the device that the syringe has been used and represents a potential biohazard.

In an alternative embodiment of the syringe according to this invention, a barrel, needle assembly, needle head, and deformable base of different structures than above are utilized wherein the deformable base is positioned between sacrificial supports in the needle assembly and an internal wedged end of the barrel. Upon completion of injection, the boot contacts the deformable base, and upon application of force at the plunger, moves the base downward, initially breaking the liquid tight seal between the base and the barrel. Continued application of force causes the sacrificial supports within the needle assembly to sever, permitting the deformable base to move the enlarged head of the needle downward until further movement of the enlarged head is blocked by the passageway in the needle assembly. With the enlarged needle head blocked by the passageway, continued force at the plunger causes the deformable base to move

around the enlarged needle head. As the deformable base moves forward, the enlarged needle head begins to protrude from the deformable base and come into contact with a thin, rupturable web on the boot of the plunger. Continued force causes the enlarged needle head to penetrate the web of the boot, positioning the enlarged needle head just inside a hollow portion of the plunger. As the plunger moves the deformable base still further, the enlarged needle head loses contact with the deformable base, which triggers a release of energy from the energy storage means in the passageway, projecting the needle into the hollow portion of the plunger. Once inside the plunger, the needle is trapped by its enlarged head within the plunger. Final movement of the plunger causes the plunger to become captured in the barrel at the back of the syringe.

BRIEF DESCRIPTION OF THE DRAWINGS

FIG. 1 of the drawings is a cross-sectional view of the syringe of this invention in its operational state.

FIG. 2 of the drawings is a cross-sectional view of the syringe of this invention in its post-operational state.

FIG. 3 is an isolated sectional view of the needle assembly of this invention.

FIG. 3A of the drawings is a cross-sectional view along line 3A—3A of FIG. 3.

FIG. 4 of the drawings is an isolated sectional view of the deformable base.

FIG. 4A is a cross-sectional view along line 4A—4A of FIG. 4 showing the cavity for the needle head and integral flexible supports.

FIG. 5 of the drawings is an elevational side view of the energy storage means.

FIG. 6 of the drawings is an elevational view of the plunger seal.

FIG. 7 of the drawings is an isolated view of the needle with its enlarged head.

FIG. 8 of the drawings is an elevational view of the needle guard, showing the needle assembly plug tethered to the tip of the needle guard.

FIG. 9 of the drawings is an isolated sectional view of the plunger boot of this invention.

FIG. 9A is a cross-sectional view along line 9A—9A of FIG. 9, showing the plunger boot.

FIG. 9B is an enlarged sectional view of the encircled area of FIG. 9.

FIG. 10 of the drawings is an isolated sectional view of the barrel of this invention.

FIG. 10A is a cross-sectional view along line 10A—10A of FIG. 10.

FIG. 11 of the drawings is an isolated sectional view of a plunger in accordance with this invention.

FIG. 11A is an enlarged sectional view of the encircled area of FIG. 11.

FIG. 11B is a cross-sectional view along line 11B—11B of FIG. 11 illustrating needle capturing means.

FIGS. 12, 13, and 14 of the drawings are cross-sectional subassembly views illustrating assembly of the needle, enlarged head, base, barrel, needle assembly, and energy storage means.

FIG. 15 of the drawings is a cross-sectional view of the plunger of this invention, showing assembly of the plunger boot and the plunger seal on the plunger.

FIG. 15A of the drawings is a partial sectional view of the plunger showing an alternative embodiment for the plunger seal.

FIG. 16 of the drawings is a cross-sectional view of the completed assembly of the syringe.

FIG. 17 of the drawings is a graph depicting the force/balance relationship upon which the syringe operation is based.

FIGS. 18, 19, 20, 21, 22, 23, 24, 25, 26, and 26A of the drawings are cross-sectional views of the apparatus of this invention showing the sequence of operation, after the injection cycle.

FIG. 27 of the drawings is an elevational view of the syringe prior to needle retraction.

FIG. 28 of the drawing is an elevational view of the syringe subsequent to needle retraction wherein an indicia has been revealed.

FIG. 29 of the drawings is a cross-sectional view of an alternative embodiment of the syringe of this invention in its operational state.

FIG. 30 of the drawings is a cross-sectional view of the alternative embodiment of the syringe of this invention in its post-operational state.

FIG. 31 of the drawings is an isolated view of an alternative embodiment of the needle assembly of this invention.

FIG. 32 of the drawings is a cross-sectional view drawn along line 32—32 of FIG. 31.

FIG. 33 of the drawings is a side view of an alternative embodiment of the deformable base of this invention.

FIG. 34 of the drawings is a cross-sectional view drawn along line 34—34 of FIG. 33.

FIG. 35 of the drawings is a side view of the needle with an enlarged head of an alternative embodiment according to this invention.

FIGS. 36, 37, 38, 39, 40, 41, 42 and 43 of the drawings are sectional views of an alternative embodiment of the syringe of this invention illustrating the sequence of operation after the injection cycle.

FIGS. 44, 45, 46 and 47 of the drawings are sectional views of embodiments of a syringe where no supports are utilized.

FIG. 48 of the drawings is a sectional view of a preferred embodiment of a syringe where no supports are utilized.

DETAILED DESCRIPTION

In accordance with this invention it has been found that a syringe may be provided for normal operation but, which upon completion of normal operation and continued movement of the plunger, results in a triggering of the needle or cannula to project such needle harmlessly into the plunger and body of the syringe. Once trapped inside the plunger and body of the syringe, the needle is no longer subject to accidental pricking or poking of human tissue thus minimizing the likelihood of transfer of contagious disease which may be carried by fluids contained on the surface of or within such needle. To prevent possible leakage of residual fluids in the needle, the syringe can be sealed after use, and after such use an automatic indication is given that the syringe represents a biohazard. Various other advantages and features will become apparent from a reading of the following description given with reference to the various figures of drawing.

FIGS. 1 and 2 of the drawings illustrate the syringe 1 of this invention with the needle 3 illustrated in FIG. 1 in its normal pre-injection position. FIG. 2 of the drawings, however, shows the final position after operation of this

invention wherein the needle 3 has been trapped and rendered harmless after the injection has taken place, and the plunger 7 has been locked within the barrel 5 of the syringe. The syringe 1 in accordance with this invention has relatively few components, which along with their function, will now be described with reference to the drawings in sequence beginning with FIG. 1.

The syringe 1 has a barrel 5 and a plunger 7 mounted therein. The needle 3 is contained within a needle assembly 9, which is fixed to barrel 5 by ultrasonic welding means or other permanent attaching means.

Needle 3 has an enlarged head 13, generally cylindrical in shape, positioned within and engaged by deformable base 11. Enlarged head 13 has a top 14, which is preferably flat and diametrically cylindrical. The top of enlarged head 13 can be concave in one embodiment. Below top 14 on enlarged head 13 are a plurality of diametrically wider areas or gradually extending bands, illustrated as areas 15 and 17, which are slightly wider than top 14. The bottom portion of enlarged head 13 is cylindrically smooth and defines a contacting portion 25 for contacting the energy storage means. By appropriately positioning the enlarged needle head 13 within deformable base 11 for a substantially mating engagement, the geometries of top 14 and area 15 of enlarged head 13 can be substantially mated and locked within deformable base 11 so that a liquid tight seal between needle head 13 and deformable base 11 is created at top 14 of enlarged head 13. As seen in FIG. 1, all of enlarged head 13 but a portion of the bottom portion is contained within the deformable base.

Needle assembly 9 has contained therein energy storage means, illustrated as spring 21, within a passageway 23, which is in contact with contacting portion 25. Deformable base 11 is positioned between barrel base shelf 2 and one end of needle assembly 9 wherein supports 31 of base 11 contact the end of the needle assembly.

Plunger 7 has a hollow 41 therein and has a boot 43 covering an end thereof which is fluid impermeable for forced movement of a fluid in barrel 5 during ordinary injection. A portion of boot 43 is illustrated as having been torn by the needle head in FIG. 2, with boot web 79 laying over in the front of plunger 7.

Preferably, plunger 7 has an enlarged thumb push 45 which, upon completion of a compression stroke, is substantially locked within a mating head portion 47 of barrel 5. As seen in FIG. 2 fitting plunger 7 within barrel 5 also produces a sealing action between plunger seal 4 and guard ring 16, preventing release of residual fluids at the back of the syringe, left in the needle after use. Plunger 7 has needle capturing means 49 therein which is illustrated in FIG. 2 as preventing the release of needle 3 from plunger 7. Also illustrated in FIG. 2 is closing member 51, illustrated as a plug, inserted into the front of needle assembly 9 to prevent residual fluids which may drain from needle 3, after the capture thereof, from leaking from the front of the syringe. It is envisioned according to this invention that various structures of closing members can be utilized, such as the plug as shown and also a capping member, as long as the opening left by needle retraction can be closed.

Reference will now be made to FIGS. 3 through 11B to more particularly illustrate the components of this invention as described above.

FIG. 3 is an isolated sectional view of needle assembly 9 of this invention. Passageway 23 is shown and is defined within needle assembly 9.

FIG. 3A of the drawings is a cross-sectional view along line 3A—3A of FIG. 3 illustrating the needle assembly 9 of this invention.

FIG. 4 is an isolated sectional view illustrating deformable base 11 which defines a passage therethrough for passage of the needle head, as discussed in more detail later. Deformable base 11 is designed to substantially matingly engage enlarged head 13. As seen in FIG. 4 base wedge 6 is provided, below where top 14 of enlarged head 13 can fit, for proper positioning of the needle in the deformable base. Further, cylindrical barrel seals 8 are provided to create proper sealing action between base 11 and barrel 5. The diameter and width of the barrel seals 8 can be made to create an optimum seal, while minimizing static and dynamic friction between base 11 and barrel 5. Also illustrated in FIG. 4 are supports 31, preferably formed as opposing, semicircular cantilevered beams projecting from the upper body 12 of base 11. Each support 31 has an inward engaging flange 32 for engaging a lower portion of enlarged head 13 and an end of the needle assembly, as shown in FIG. 1. Needle head seal 10 is further illustrated in FIG. 4 and is where top 14 of enlarged head 13 can fit. The diameter and width of needle head seal 10 is designed to provide optimum sealing with top 14, while minimizing static and dynamic friction between enlarged head 13 and base 11.

FIG. 4A of the drawings is a cross-sectional view along line 4A—4A of FIG. 4 illustrating deformable base 11. A preferred material for base 11 is an elastomer. Supports 31 are illustrated in the preferred embodiment as a pair of opposing, semicircular cantilevered beams, however, it is envisioned according to this invention that supports 31 could be connected and unitary or divided up further.

FIG. 5 of the drawings is an elevational side view of the energy storage means illustrated as spring 21.

FIG. 6 of the drawings is an elevational view of plunger seal 4 illustrated in one embodiment as an O-ring seal.

FIG. 7 of the drawings is an isolated view of needle 3, or cannula, with enlarged head 13. Top 14, wider areas 15 and 17, and contactor 25 on the bottom portion are illustrated. Also illustrated in phantom is the hollow portion 16 of the needle.

FIG. 8 shows a side view of a needle guard 12, with closing member 51 attached at the end thereof. Closing member 51 is attached or tethered by a breakable tab 52 which can be of plastic construction and which is broken to remove closing member 51. As illustrated, closing member 51 is preferably a plug which is attached by tab 52 to the needle guard at an angle wherein tab 52 connects to closing member 51 away from the end of closing member 51 which can be inserted or plugged into the needle assembly after needle retraction. As discussed above, the closing member of this invention can be of various types, such as a cap or a plug as shown, as long as the opening left by needle retraction can be closed. Preferably, the opening is closed off so that a liquid tight seal is obtained. The angular attachment of the closing member preferred herein and illustrated in FIG. 8 allows a person completing needle retraction to handle just the needle guard to insert the closing member into the needle assembly where the needle was positioned prior to retraction. Quite advantageously, this can be accomplished with the user's hands always positioned behind the opening in the needle assembly left as a result of needle retraction.

FIG. 9 is an isolated sectional view of boot 43 of this invention. FIG. 9A of the drawings is a cross-sectional view along line 9A—9A of FIG. 9 illustrating boot 43. FIG. 9B is an enlarged sectional view of the encircled area of FIG. 9. Referring to FIGS. 9, 9A and 9B, a thin, rupturable web 79 is shown as a portion of boot 43. To aid in the rupturing

process of the web, tear groove 26 and tear groove 28, shown in FIG. 9B, are provided. The thickness of web 79 and the tear grooves are selected to withstand normal operating pressures within syringe 1, as shown in FIG. 1, but to allow relative ease in the puncturing of web 79 by enlarged needle head 13, shown in FIG. 6. The preferred material for boot 43 is an elastomer.

FIG. 10 is an isolated sectional view of barrel 5. FIG. 10A of the drawings is a cross-sectional view along line 10A—10A of FIG. 10 showing finger support flange 81 of barrel 5 of this invention. Referring to FIGS. 10 and 10A, at the finger support flange 81 of barrel 5 is shown an undercut 47 for locking the plunger into the barrel. At the opposite end of barrel 5, base shelf 2 and nose shelf 14 are illustrated. These internal offsets receive the base and the needle assembly respectively.

FIG. 11 of the drawings is an isolated sectional view of plunger 7 in accordance with this invention. Capturing means 49 is illustrated. Plunger boot termination 16 is also illustrated and is designed to receive rupturable boot 43.

FIG. 11A is an enlarged sectional view of the encircled area of FIG. 11 and illustrates cavity 30 for receiving plunger seal 4 and inclined surface 18 for fitting and substantially locking the plunger into the body of the syringe.

FIG. 11B is a cross-sectional view along line 11B—11B of FIG. 11 further illustrating needle capturing means 49.

Given the components described above, assembly in several primary steps is required to produce the syringe. FIGS. 12 through 16 illustrate these steps so as to result in a finished product. Needle 3 is first inserted into enlarged head 13. With reference to FIG. 12, the first assembly step is accomplished by inserting needle 3 into deformable base 11 between flexible supports 31 for a substantially mating engagement. Base wedge 6 is positioned between top 14 and wide area 15 of enlarged head 13 which blocks needle 3 movement in both directions. A liquid tight seal between enlarged head 13 and needle head seal 10 on base 11 as shown in FIG. 12 is created around the edge of top 14 of enlarged head 13. With needle 3 blocked into base 11, the next assembly step is accomplished.

In the next step of the assembly process, the subassembly in FIG. 12 is inserted into the front end of barrel 5 as shown in FIG. 13, until base 11 contacts and is positioned against base shelf 2. When base 11 is completely inserted as shown in FIG. 13, base 11 is compressed circumferentially in the direction of needle head 13, and a liquid tight seal is produced between base 11 and barrel 5.

To complete assembly of needle assembly 9 with barrel 5, as shown in FIG. 14, the energy storage means is first placed into passageway 23. The preferred embodiment of energy storage means is spring 21. Needle assembly 9 is then fixed to barrel 5 by threading needle 3 through the center of spring 21 in passageway 23 and inserting needle assembly 9 into the front of barrel 5, until needle assembly 9 contacts and is positioned against nose shelf 14. Permanently joining needle assembly 9 and barrel 5 can be accomplished by ultrasonic welding around the circumference of barrel 5 at overlap 81, or any other permanent attaching means can be utilized. Attachment of needle assembly 9 to barrel 5 creates a liquid tight seal between the two parts. As a result of this assembly step, the end of needle assembly 9 is positioned just in contact with engaging flanges 32 of supports 31, thus preventing movement of base 11 and needle 3 contained therein for normal syringe use.

In the final step of assembly, plunger seal 4 and boot 43 are placed onto plunger 7 as shown in FIG. 15. Boot 43 is

preferably placed onto plunger 7 so that web 79 is just at the end of the plunger. Plunger 7 is then inserted into barrel 5. FIG. 15A is a partial sectional view of the end of the plunger with a plunger seal showing an alternative embodiment wherein the plunger seal is formed as an integral and unitary part of the plunger so that the seal as provided by use of an O-ring is accomplished by forming the ring as an integral part of the plunger. To complete the assembly as shown in FIG. 16, needle guard 12 is placed on needle assembly 9, with closing member 51 tethered at the tip of needle guard 12. It will be apparent to those in the art that there exists other possible sequences of assembly other than those described herein that can be used to produce the completed assembly as shown in FIG. 16, producing the same syringe ready for operation.

The syringe operates on a “force/balance” principal as depicted in the graph of FIG. 17. In the graph normal operation is represented by regions I and II. In these regions limited positive and negative forces are applied between the plunger 7 and body 5, shown in FIG. 18, for normal operating functions of filling the syringe and for injections. Positive forces are defined as forces which move the plunger into the syringe body, while negative forces are defined as those forces which pull the plunger from the syringe body. Typical “filling” and “injection” cycles are depicted in regions I and II, respectively. As long as the positive force applied between the plunger 7 and body 5 of syringe 1 is below threshold 34, base 11 balances the operating force and remains in its assembled position, as shown in FIG. 18. But, for positive forces applied to the syringe above threshold 34, base 11 becomes unbalanced and begins to move in the direction of needle assembly 9. Once force above threshold 34 is applied and maintained, operation of the syringe moves into region III, where the needle is retracted into the plunger of the syringe. In region III, points 83, 85 and 87 represent a typical device where base 11 first begins to move, needle head 13 is released and plunger 7 becomes substantially locked into body 5 respectively.

The sequence of operation will now be described with regard to FIG. 1 and FIGS. 18 through 28. As can be seen, FIG. 1 is a cross-sectional view of safety syringe 1. For normal syringe operating forces, safety syringe 1 operates as any conventional syringe. For use, the syringe is filled from an ampule in a normal manner, as standard procedure dictates. Once filled, the injection cycle is accomplished, again according to standard practice. At completion of the injection cycle, plunger boot 43 is just mating with base 11, as shown in FIG. 18, and all fluids, which can be, are expended from syringe 1 through the needle. Before the syringe is released or discarded, by the user, the needle retraction cycle should be accomplished.

At the beginning of the needle retraction cycle, syringe 1 is usually held between the index finger and the middle finger at support flange 81, with the thumb resting on thumb push 45, presumably the same as the syringe was held at completion of the injection cycle. Plunger 7 is contacting base 11 at boot 43, as shown in FIG. 18.

With reference to FIG. 19, force is applied between finger support flange 81 and thumb push 45. This force is transmitted along plunger 7 to deformable base 11 and supports 31. As the force increases sufficiently supports 31 begin to flex open away from one another as shown in FIG. 19, wherein engaging flanges 32 move away from and lose contact with the enlarged needle head 13 and flex open just enough to pass over passageway 23 and to allow further movement of base 11 and needle 3 toward an end of the barrel.

As shown in FIG. 20, the continued application of force applied to plunger 7 continues to cause supports 31 to ride up on and around the needle assembly as deformable base 11 moves further. As the deformable base and the enlarged needle head are forced toward the end of the barrel, the bottom portion of enlarged head 13, which extends partially into the needle assembly prior to the retraction process, is forced further into the needle assembly, until wide area 17 contacts the end of the needle assembly and prevents any further movement of the enlarged head into the needle assembly by its greater diameter than passageway 23 within the needle assembly. This allows the plunger to force the base to deform and pass around the now stationary enlarged needle head. Spring 21 is fully compressed in the process by contactor 25 of the needle head.

With reference now to FIG. 21, as deformable base 11 moves further toward the end of the barrel, needle head 13 begins to protrude from base 11 and come into contact with web 79 of boot 43 on plunger 7. Continued force causes further translation of base 11 and needle head 13 to tear web 79 of boot 43, positioning enlarged needle head 13 just inside hollow 41 of plunger 7 while wide area 17 remains embedded within deformed base 11, as shown in FIG. 21.

With reference to FIG. 22, continued translation of deformable base 11 causes wide area 17 to eventually lose contact with deformable base 11, creating a trigger-like release of enlarged head 13. Upon this trigger-type action, energy stored within spring 21 is released and imparted to needle 3 to project needle 3 into hollow 41 of plunger 7, as illustrated in FIG. 23.

Referring now to FIG. 24, it is seen that needle 3, at its enlarged head 13, contacts capturing means 49 which is a flexible catch that elastically flexes to permit enlarged needle head 13 to pass through the constriction formed by capturing means 49 and an inner wall of plunger 7. This is further illustrated in FIG. 25 where needle head 13 is shown having passed capturing means 49 and being captured within hollow 41 of plunger 7 wherein the needle head will move back past the capturing means. At this point, it should be noted that plunger 7 has been matingly and substantially locked within barrel 5 by mating head portion 47 engaging a portion of the plunger near thumb push 45. As shown in FIG. 26A, a liquid tight seal between plunger seal 4 and guard ring 16 is created.

To finish the operational sequence, closing member 51 tethered to the end of needle guard 12, can be inserted into opening 22 of needle assembly 9 as shown in FIG. 26 and described with reference to FIG. 8. Closing member 51 can be forced into position by pressing it against a heavy, solid object. Once closing member 51 is lodged into position, closing member 51 can be separated from needle guard 12 with a twisting action, leaving syringe 1 as shown in FIG. 26. This closure process can therefore be advantageously accomplished with a user's hands always remaining behind the opening left by the retracted needle.

As a result of accomplishing the needle retraction cycle as described, syringe 1 is left as shown in FIG. 26. Also preferably accomplished during the needle retraction cycle is revelation and amplification of an indicia or label such as biohazard label 24, as shown in FIG. 28. Before the needle retraction cycle, base 11 is under biohazard label 24 as seen in FIG. 27 wherein the label is not readable. It is preferred that biohazard label 24 be printed in black, or any other appropriate color, and that base 11 also be the same or substantially similar color so that biohazard label 24 is unnoticeable to the user. It is also preferred that boot 43 be

of a different, contrasting color. After the needle retraction cycle, base 11 is no longer left under the biohazard label, and boot 43 is under the label, as shown in FIG. 28. Since boot 43 is any appropriate highly contrasting color relative to base 11 and the biohazard label, such as orange when the other two are black, biohazard label 24 is significantly revealed and amplified and becomes very noticeable to the user or other people, as shown in FIG. 28.

FIGS. 29 and 30 of the drawings illustrate the syringe 101 of this invention with the needle 103 illustrated in FIG. 29 in its normal pre-injection position. FIG. 30 of the drawings, however, shows the net result of this invention wherein needle 103 has been trapped and rendered harmless after the injection has taken place, and the plunger has been locked within the barrel of the syringe. Syringe 101 in accordance with this invention is similar to syringe 1 described above and has relatively few components. Components of syringe 101 that are different from syringe 1 above are the deformable base, the enlarged needle head, and the needle assembly and the barrel.

Syringe 101 has a barrel 105 and a plunger 107 mounted therein. Needle 103 is contained within a needle assembly 109, which is fixed to barrel 105 by ultrasonic welding means or other permanent attaching means.

Needle 103 has an enlarged head 113 mounted within deformable base 111. Enlarged head 113 has a wedge portion 115 and a circular flange portion 117. By appropriately positioning the enlarged head 113 within deformable base 111, the geometries of the flange portion and wedge portion of enlarged head 113 substantially lock such enlarged head portion within the deformable base, while also creating a liquid tight seal between needle head 113 and deformable base 111.

Needle assembly 109 has contained therein energy storage means, illustrated as spring 121 within a passageway 123. Enlarged needle head 113 has a contacting portion 125 which contacts energy storage means 121. Sacrificial supports 131 position deformable base 111 within needle assembly 109.

Plunger 107 has a hollow 141 therein and is terminated by a boot 143 having a rupturable web 179, the boot being fluid impermeable for movement of a fluid in the barrel during ordinary injection. Web 179 of boot 143 is illustrated as having been ruptured in FIG. 30.

Preferably, plunger 107 has an enlarged compression section at thumb push 145 which, upon completion of a compression stroke, is locked within a mating head portion 147 of barrel 105. Plunger 107 has needle capturing means 149 therein which is illustrated in FIG. 30 as preventing the release of needle 103 from plunger 107. Also illustrated in FIGS. 29 and 30 is an absorption means 151, such as cotton, to collect any fluids which may drain from needle 103 after the capture thereof.

FIG. 31 of the drawings is an isolated view of needle assembly 109 of this invention. Sacrificial supports 131 and passageway 123 are illustrated in partial phantom.

FIG. 32 is a cross-sectional view along the line 32—32 of FIG. 31, further illustrating sacrificial supports 131 and passageway 123 within needle assembly 109.

FIG. 33 of the drawings is a side view of deformable base 111. A preferred material for base 111 is an elastomer. As seen in FIG. 33, counterbore 173 and throbore 175 are provided for proper positioning of the needle in the deformable base.

FIG. 34 is a cross-sectional view along the line 34—34 of FIG. 33 further illustrating deformable base 111.

FIG. 35 of the drawings is a side view of needle 103 or cannula. Contactor 125, circular flange 117 and enlarged head 113 with wedge portion 115 are illustrated. Also illustrated in phantom is the hollow portion 116 of the needle.

The sequence of operation of syringe 101 will now be described with regard to FIG. 29 and FIGS. 36 through 43. As can be seen, FIG. 29 is a cross-sectional view of safety syringe 101. For normal syringe operating forces safety syringe 101 operates as any conventional syringe. For use, the syringe is filled from an ampule in a normal manner, as standard procedure dictates. Once filled, the injection cycle is accomplished, again according to standard practice. At completion of the injection cycle, plunger 107 is just mating with base 111, as shown in FIG. 36, and all fluids, which can be, are expended from syringe 101. Before the syringe is released, or discarded, by the user, the needle retraction cycle should be accomplished.

At the beginning of the needle retraction cycle, syringe 101 is usually held between the index finger and the middle finger at support flange 181, with the thumb resting on thumb push 145, presumably the same as the syringe was held at completion of the injection cycle. Plunger 107 is just mated with base 111 at boot 143, as shown in FIG. 36.

With reference to FIG. 37, force is applied between finger support flange 181 and thumb push 145. This force is transmitted along the plunger to deformable base 111 and sacrificial supports 131. As the force increases sufficiently, the liquid tight seal between barrel 105 and deformable base 111 is broken, and sacrificial supports 131 begin to fracture.

As shown in FIG. 38 further force is applied at plunger 107. Sacrificial supports 131 are severed and deformable base 111 moves forward, further compressing energy storage means 121. Deformable base 111 moves forward until circular flange 117, on needle head 113 which is in translation with base 111, comes into contact with the end of needle passageway 123.

With reference now to FIG. 39 enlarged needle head 113 is blocked by passageway 123, and continued force at plunger 107 causes deformable base 111 to deform and move around circular flange 117 on enlarged needle head 113 as deformable base 111 moves forward, enlarged needle head 113 begins to protrude from base 111 and come into contact with rupturable web 179 of boot 143, positioning enlarged needle head 113 just inside hollow 141 of plunger 107 while circular flange 117 remains embedded within deformed base 111, as shown in FIG. 39.

With reference to FIG. 40, continued translation of deformable base 111 causes circular flange 117 to eventually lose contact with deformable base 111, creating a trigger-like release of circular flange 117. Upon this trigger-type action, energy stored within spring 121 is released and imparted to needle 103 to project needle 103 into hollow 141 of plunger 107, as illustrated in FIG. 41.

Referring now to FIG. 42, it is seen that needle 103, at its enlarged head 113, contacts capturing means 149 which deforms to permit enlarged head 113 to pass through the constriction formed by capturing means 149. This is further illustrated in FIG. 43 where needle 103 is shown captured within hollow 141 of plunger 107. At this point, it should be noted that plunger thumb push 145 has been locked within the mating section 147 of barrel 105. As syringe 101 is tilted downward, fluids remaining in needle 103 flow within hollow 141, down the exterior side of passageway 123 to absorbent means 151 where the fluids are absorbed and prevented from being released from the interior of syringe 101.

FIGS. 44 and 45 of the drawings illustrate syringe 1 of this invention wherein the flexible supports are not utilized. It has been found according to this invention that syringe 1 can function to retract the needle without supports 31 when small syringes, such as 1 cc syringes are used.

FIGS. 46 and 47 of the drawings illustrate syringe 101 of this invention wherein sacrificial supports 131 are not utilized. It has been found according to this invention that syringe 101 can function to retract the needle without sacrificial supports 131 when small syringes, such as 1 cc syringes, are used.

FIG. 48 of the drawings illustrates a preferred embodiment of a syringe 161 according to the present invention where no flexible or sacrificial supports are utilized. This embodiment is particularly suitable for small syringes, such as 1 cc, and includes a cylindrical deformable base 163 having a central passage therethrough which matingly engages a cylindrical enlarged needle head 165 which is attached to an end of hollow needle 167. A needle assembly 169 is attached to an end of barrel 171 opposite an end for insertion of plunger 173. Needle 167 passes through a passageway defined through needle assembly 169, and an energy storage means such as spring 173 is positioned within the passageway. Enlarged needle head 165 includes two cylindrical sections of different diameters with the larger section being held entirely within base 163 prior to initiation of needle retraction and the lower cylindrical section extending partially into the needle assembly and having a contacting portion 175 on an end thereof for contacting spring 173. Base 163 is biased in position by spring 173 against shelf 177 and by friction from barrel 171 prior to initiation of needle retraction.

Needle ejection through web 179 of boot 181 occurs as discussed with reference to syringe 1 above, which is incorporated herein, with base 163 being forced downwardly around the needle assembly except no supports are utilized. As base 163 moves downwardly, the enlarged needle head tears web 179, and when enlarged needle head 165 loses contact with base 163, needle 167 is ejected into plunger 7.

It is thus seen that this invention provides a novel syringe apparatus which minimizes the likelihood of accidental puncture, is operable by a single hand and which upon completion of injection captures the utilized needle and renders such harmless within the plunger and body of the syringe. As various other advantages and features will become apparent to those of skill in the art from a reading of the foregoing description which is exemplary in nature, such modifications and variations are embodied within the scope of this invention as defined by the following appended claims.

We claim:

1. A syringe apparatus comprising:

- a barrel;
- a hollow needle extending from an end of the barrel, the needle having a head comprising at least a portion of a flange;
- a plunger movable within the barrel for moving a fluid out of the barrel through the needle;
- a movable base adapted to bear against the flange and abut the inside of the barrel in order both to seal one end of the barrel and releasably to constrain the head in its initial position in order to prevent premature ejection of the needle into the barrel; and
- the plunger receivable within an end of the barrel opposite the needle, whereby movement of the plunger toward

13

the needle end of the barrel causes the base to move relative to the flange, thus allowing the needle to move within the interior of the plunger.

2. The apparatus according to claim 1 wherein said seal is a ring formed integrally as a part of said plunger.

3. A syringe comprising:

a needle having a head;

a barrel;

a plunger sized and shaped to be received in an end of the barrel and to be movable therein;

a movable base adapted to releasably retain the head of the needle to prevent premature ejection of the needle into the barrel;

a spring at least partially compressed within a needle assembly that comprises a passage through which the needle passes and contacting at least a portion of the head of the needle; and

wherein the plunger is moved within the barrel causing the base to release the head and to retract the needle.

4. The apparatus of claim 3, wherein the spring biases the base.

5. The syringe apparatus of claim 3, wherein the base is deformable.

6. The syringe apparatus of claim 3, wherein movement of the plunger causes further compression of the spring.

7. The syringe apparatus of claim 3, further comprising: a rupturable portion disposed proximate the needle head; wherein the needle passes through the rupturable portion during retraction.

8. The syringe apparatus of claim 3, wherein the needle head is generally cylindrical.

9. A syringe comprising:

a nose coupled to a body of the syringe, the nose comprising: (a) an outer wall that forms an end of the syringe from which a hollow needle projects; (b) a shaft extending from the outer wall toward the syringe body and at least partially surrounding a spring; and (c) the needle having a head with a lip that releasably supports a movable base surrounding at least a portion of the needle head; and

a plunger that when activated causes the base to move relative to the head so that the base disengages from the lip of the head, which thereby allows the spring to propel the needle into the plunger.

10. A syringe according to claim 9 wherein the plunger activation further causes at least a portion of the base to engage at least a portion of the shaft, which thereby holds the base in a fixed position after firing of the spring.

11. A syringe according to claim 10 wherein the plunger has on one end a shelf that assists in holding a gasket surrounding at least a side portion of the plunger, whereby the gasket forms a seal between the plunger and the body of the syringe.

12. A syringe according to claim 11 wherein the one end of the plunger defines a generally cylindrical wall whose diameter is greater than the diameter of the needle head and needle.

13. A syringe according to claim 12 wherein upon plunger activation the wall acts to move the base toward the nose in order to release the head of the needle.

14. A syringe according to claim 9 wherein the end of the plunger has a movable portion and the head moves the portion in order to form an opening through which the needle passes when the spring fires.

15. A retractable syringe comprising:

(a) a syringe body having a nose portion defining a passageway through which a needle is at least partially threaded;

14

(b) a needle and a head thereon,

(c) a movable base coupled to at least a portion of the needle, whereby when the needle is threaded through the passageway in a ready to use state, the base assists in retaining the needle in place; and

(d) a plunger that, when activated by a user, moves the base relative to the head, after which the head releases from the base and a spring fires the head and needle into the syringe.

16. A syringe according to claim 15 wherein the plunger has an end portion that abuts a portion of the needle head during activation, by which the head is caused to move the end portion relative to the plunger in order to create an opening through which the needle can pass as it is propelled by the spring.

17. A syringe according to claim 16 wherein the head has (1) a first portion that contacts one end of the spring, which biases the head toward the base, and (2) a circular flange portion that bears against a second portion of the base in order temporarily to restrain the needle against the spring bias.

18. A syringe according to claim 15 wherein upon plunger activation the passageway blocks the plunger from moving the enlarged needle head past the passageway so that continued force at the plunger moves the base past the flange, which loses contact with the base and triggers a release of the spring energy in order to project the needle into a hollow portion of the plunger.

19. A syringe according to claim 18 wherein the plunger has an end portion that abuts against the needle head during activation, whereby the head moves the end portion relative to the plunger in order to create an opening through which the needle can pass as it is propelled by the spring.

20. A syringe according to claim 15 wherein the base is deformable and ring-shaped.

21. A method for retracting a syringe having a body, plunger, needle, spring and movable base, the method comprising:

placing a portion of the needle in the center of the spring and compressing the spring between a nose portion of the body and the base that couples to at least a portion of an enlarged head on the needle;

temporarily fixing the base relative to the body via either friction between the base, the body and the head or by a lip formed to restrain the base against the spring that biases the head toward an interior of the plunger;

moving the plunger against the base;

blocking movement of the enlarged head via a passageway through which the needle threads; and

further moving the plunger to cause the base to move relative to the head, whereby the base loses contact with the head and the spring fires the needle into the plunger.

22. A method according to claim 21 further comprising making a final movement of the plunger in order to lock the plunger in the back of the body of the syringe.

23. A method according to claim 21 wherein first moving the plunger against the base further compresses the spring.

24. A method according to claim 21 in which the passageway is a generally cylindrical shaft projecting from the nose portion, which is separate from and attachable to the body.