



US005986570A

United States Patent [19]

[11] Patent Number: **5,986,570**

Black et al.

[45] Date of Patent: **Nov. 16, 1999**

[54] **METHOD FOR RESOLVING SIGNAL COLLISIONS BETWEEN MULTIPLE RFID TRANSPONDERS IN A FIELD**

5,802,080 9/1998 Westby 371/37.01

FOREIGN PATENT DOCUMENTS

[75] Inventors: **Donald L. Black, Erie; Dale Yones, Boulder, both of Colo.**

- 0 405 695 1/1991 European Pat. Off. .
- 0 685 825 12/1995 European Pat. Off. .
- 0 689 151 12/1995 European Pat. Off. .
- 0 702 324 3/1996 European Pat. Off. .
- 0 709 803 5/1996 European Pat. Off. .
- 0 755 026 1/1997 European Pat. Off. .

[73] Assignee: **Micron Communications, Inc., Boise, Id.**

Primary Examiner—Michael Horabik
Assistant Examiner—Yves Dalencourt
Attorney, Agent, or Firm—Wells, St. John, Roberts, Gregory & Matkin, P.S.

[21] Appl. No.: **08/922,491**

[22] Filed: **Sep. 3, 1997**

[51] Int. Cl.⁶ **H04B 7/00**

[57] ABSTRACT

[52] U.S. Cl. **340/825.54; 340/825.34; 340/825.31; 714/797; 714/799; 714/748; 714/749**

Communications between an RFID interrogator and an RFID transponder require that no more than one transponder be present in the reading range of the interrogator and transmitting into motion at any given time. If multiple transponders are in the field, then a collision between the return signals of the transponders occurs, rendering the signals unreadable. A method to resolve the collisions and allow for accurate transmission of each transponder's data is given. This method is especially effective over other methods when the transponder is a read-only type of device, whereby there is no communications interrogator on board the read-only transponder.

[58] Field of Search 340/825.54, 825.34, 340/825.31; 371/32, 33, 37.01, 36; 714/797, 799, 748, 749

[56] References Cited

U.S. PATENT DOCUMENTS

- 5,339,073 8/1994 Dodd et al. 340/825.31
- 5,583,819 12/1996 Roesner et al. 340/825.34
- 5,742,618 4/1998 Lowe 371/36
- 5,745,049 4/1998 Akiyama et al. 340/825.54
- 5,751,570 5/1998 Stobbe et al. 340/825.54

23 Claims, 6 Drawing Sheets

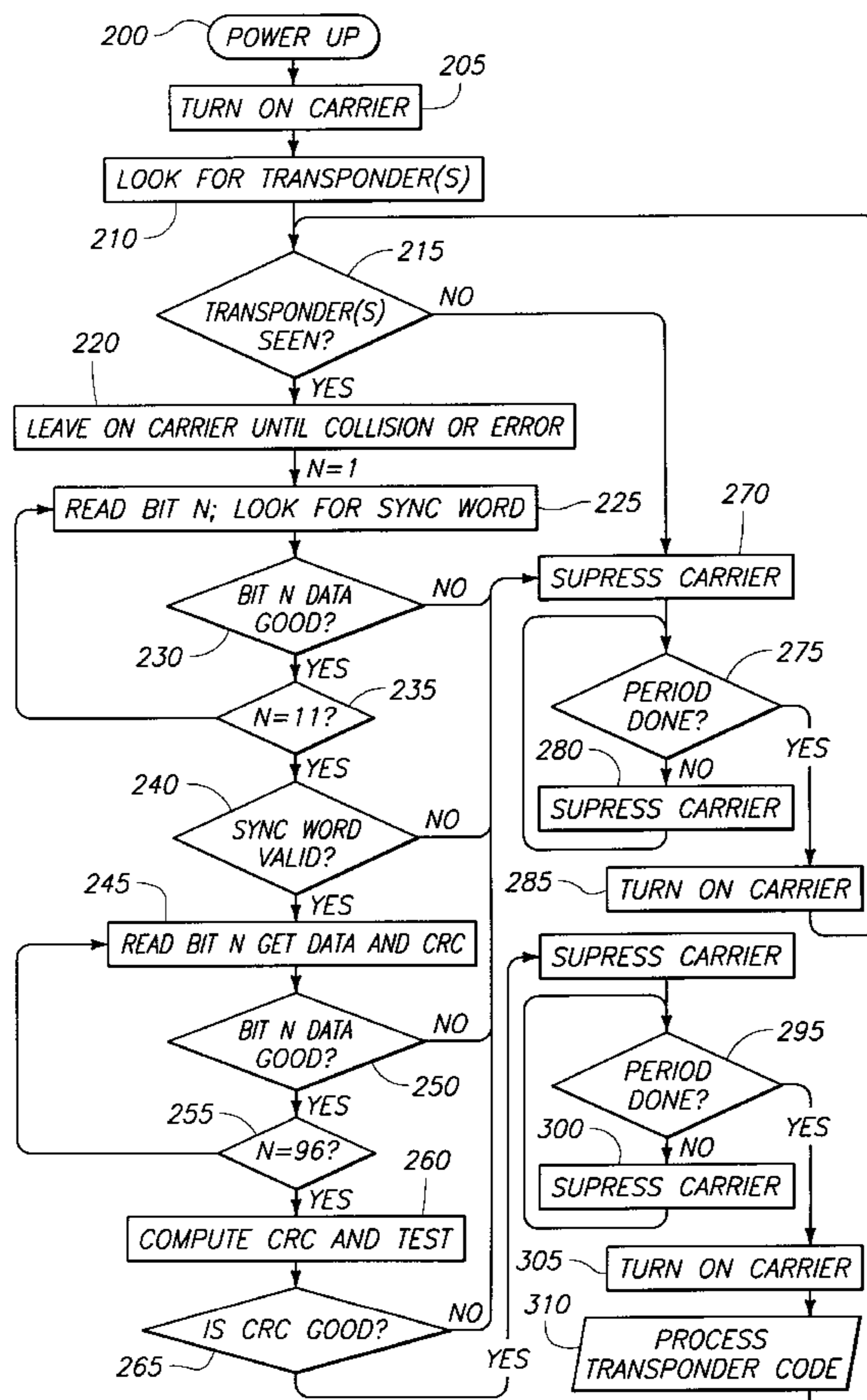

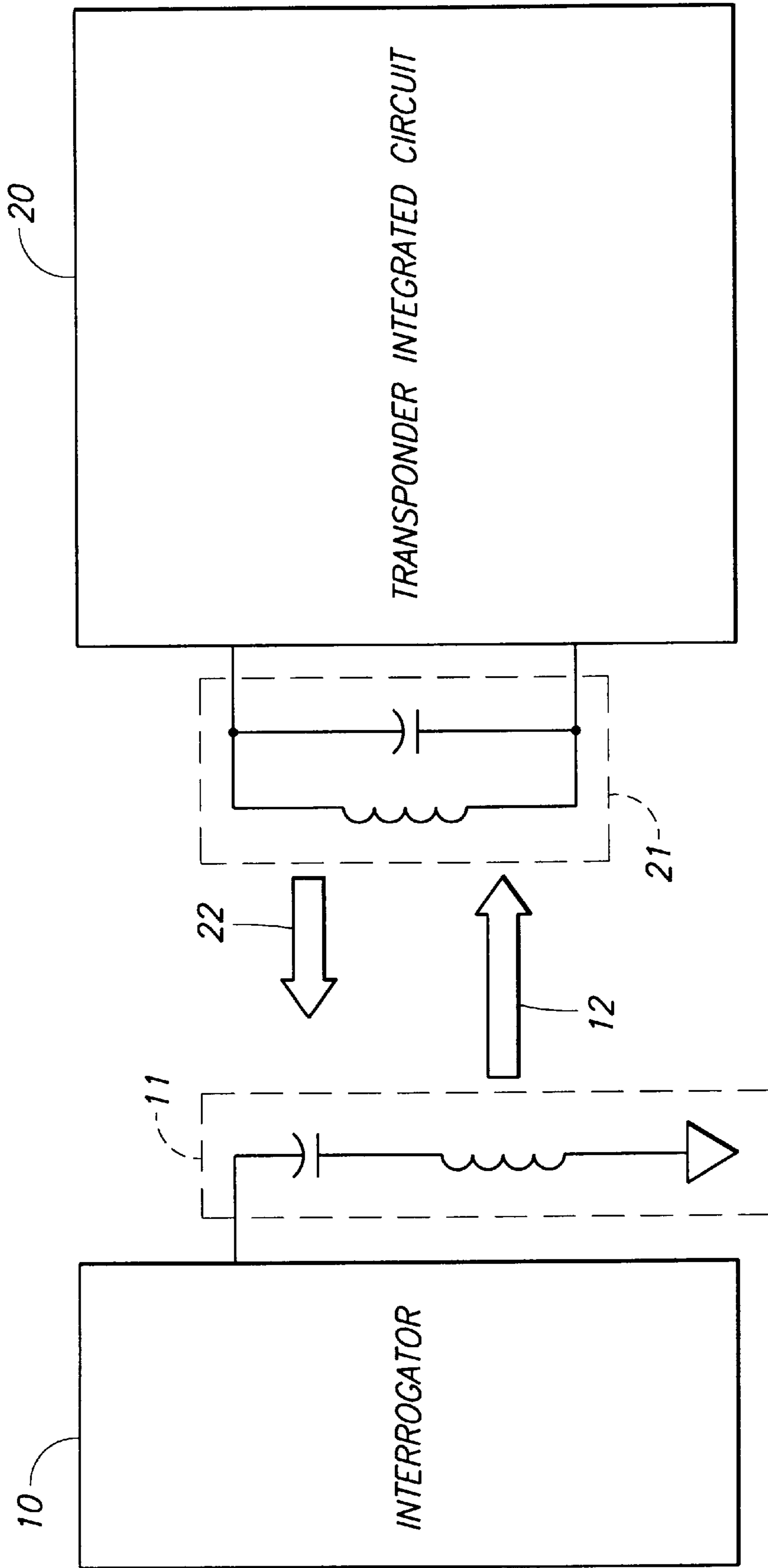

FIG. 1
PRIOR ART

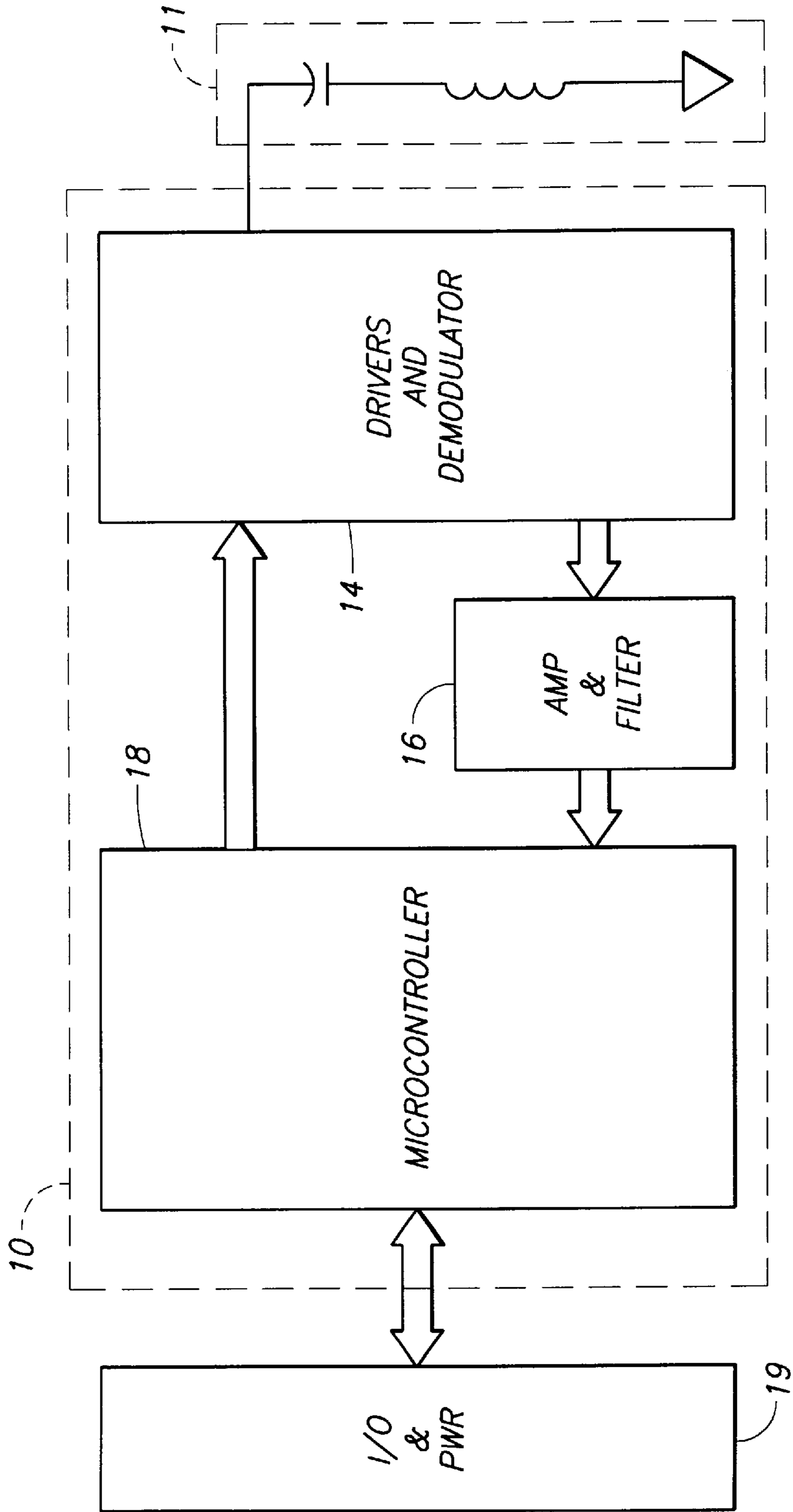

FIG. 2
PRIOR ART

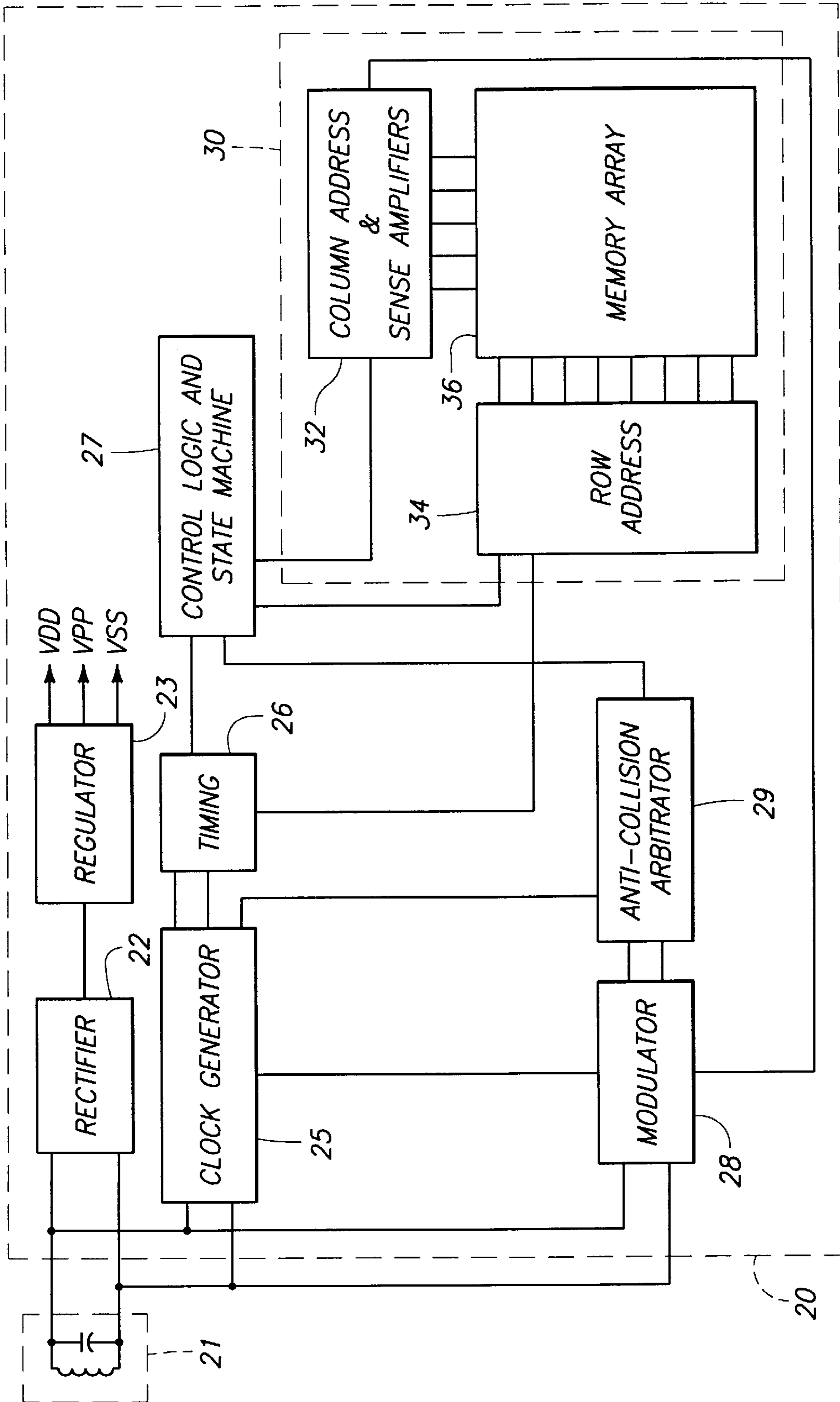
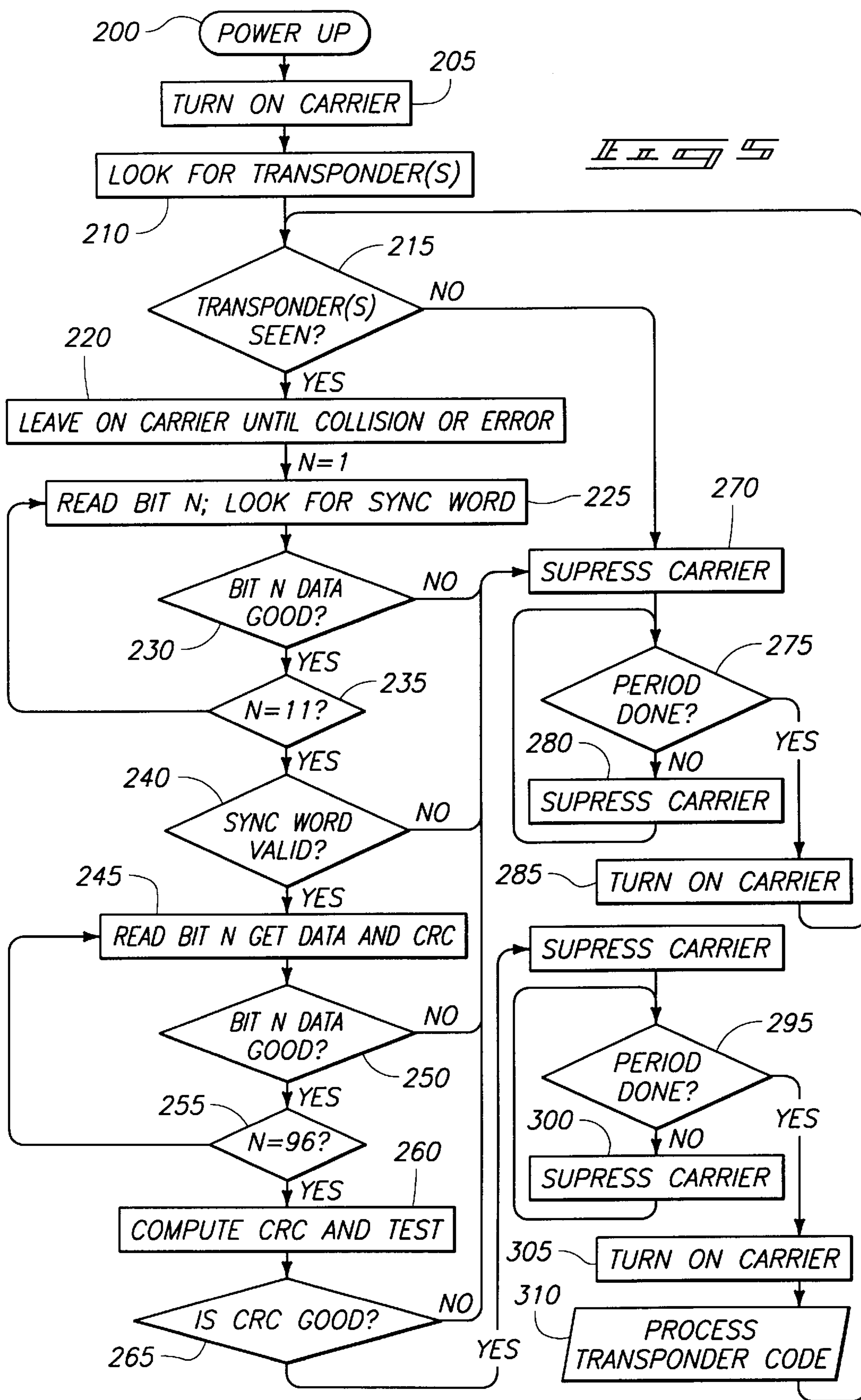

FIG. 3



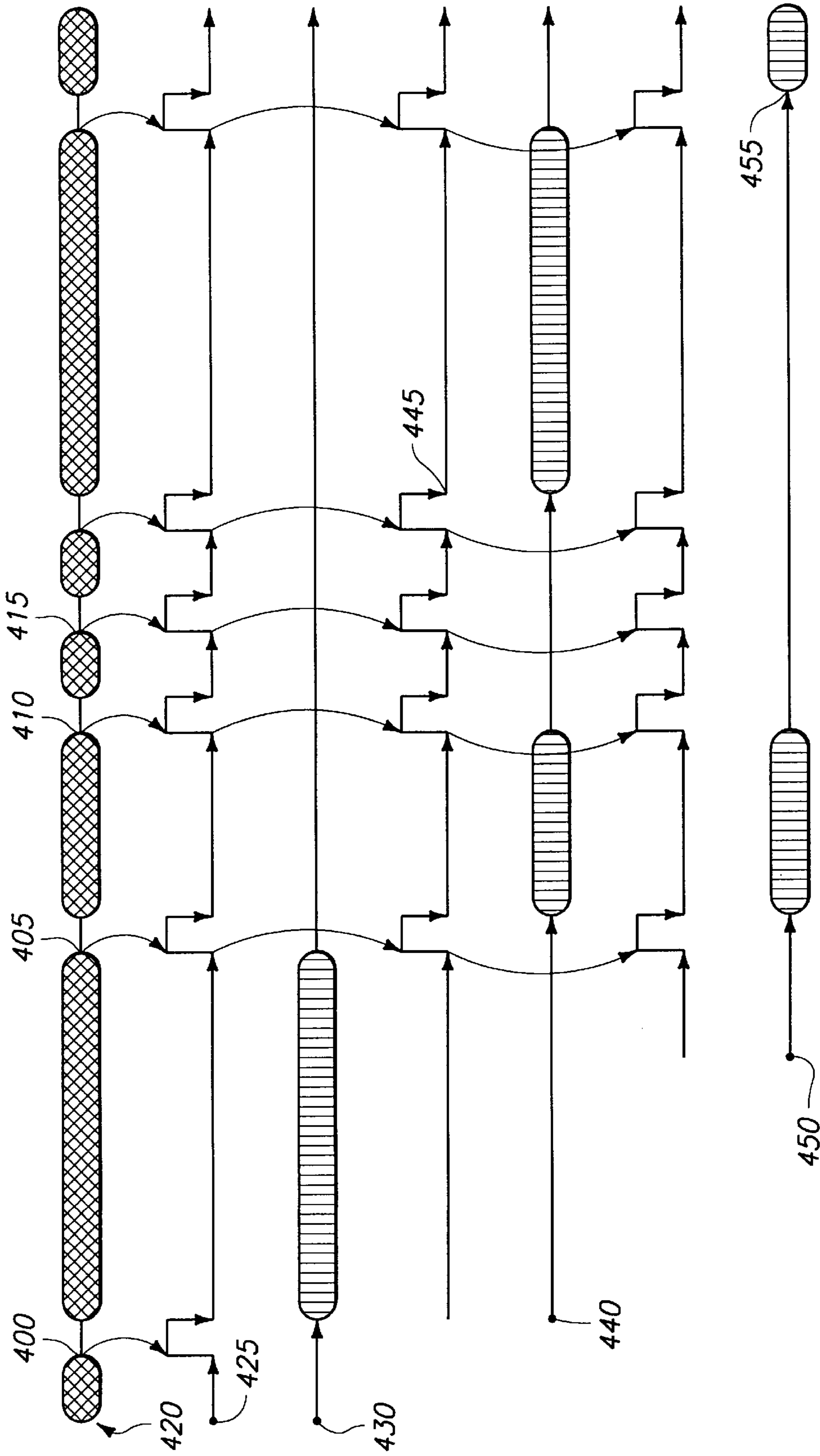

FIG. 6

METHOD FOR RESOLVING SIGNAL COLLISIONS BETWEEN MULTIPLE RFID TRANSPONDERS IN A FIELD

FIELD OF THE INVENTION

The present invention relates to electronic identification devices and systems, and in particular, to devices where their application in a system will allow more than one device to be present in the interrogator field at any moment in time. Furthermore, the system requires that all the devices in the field are properly identified by the interrogator.

BACKGROUND OF THE INVENTION

There are methods currently in use that provide varying degrees of success in resolving the collision of the tags, and especially in tags with read/write capability, where communications to the tags is facilitated by an on-board interrogator in the RFID tag. In such a tag, the interrogator can send signals to allow tags to respond with a random number that is manipulated by the interrogator and transmitted to all tags in the field. Only the tag that matches the computed number generated by the interrogator will transmit its data. This process continues until all tags have transmitted their data. This method significantly increases the complexity of the transponder by issuing the transponder to include an interrogator and being only partially effective for regulation of collisions.

Another method of collision resolution is to cause tags to transmit at different frequencies, thereby avoiding a collision of signals. This method significantly increases the complexity of the interrogator while being only partially effective for resolution of the collision.

Yet another method involves the use of spread spectrum techniques. The technique can be either direct sequence spread spectrum (DSSS) or frequency hopping. Either method requires correlation of the signal in the interrogator and requires a very complex interrogator system.

Another method of collision resolution uses part of the unique identification code of the transponder to provide a specific time whereby the transponder transmits its data, and all other times, the transponder remains inactive. This feature is limited by the vast number of unique transmission slots available, and the time required to read all the possible tags in the field. Moreover, a single transponder in the field could take an inordinate amount of time to be read. If the unique identification code is truncated to allow for faster performance, then the probability of an un-resolvable collision occurs due to the duplication of codes.

One other method for resolution is the utilization of a random oscillator and a binary counter on each transponder which enables transmission from the transponder when the counter is in a specific state. All other times the transponder is inactive. This method has the disadvantage of requiring alignment of all the transponders asynchronously before coherent data can be received by the interrogator.

All the above methods require either the use of expensive and complicated interrogator systems, a read-write tag, or they are excessively slow to resolve a useful number of tags.

SUMMARY OF THE INVENTION

The present invention addresses the limitations of the above solutions to the collision problem by providing a simple system for collision resolution that does not require the transponder to have read-write capability nor does the solution require additional complexity to the interrogator to perform the anti-collision function.

The invention comprises a method for sending data from a transponder having at least one memory, a transmission criteria, a transmit state and a full cycle flag. The method comprises the steps wherein the transponder: detects the interrogator, such as by receiving a carrier signal from the interrogator; determines that it is time to transmit the data by verifying that it is the transmit-armed state and that the carrier signal has been modified in a predetermined manner; transmits its data in groups of one or more data bits; determines whether its complete data has been read by the interrogator during the transmission of its data; and sets a full cycle flag after sending its complete data transmission. The transponder determines that the interrogator has read the complete data transmission by verifying that the carrier signal has not been modified until the full cycle flag is set. If the transponder determines that the interrogator did not read the complete data transmission, then the transponder stores a number in memory, iteratively changes the number until the number stored in memory satisfies the transmission criteria, and then transmits its data. This process of transmitting and determining whether the complete data has been read by the interrogator during data transmission is repeated until the transponder determines that the interrogator has read the complete data transmission.

The invention also comprises a method for an interrogator to read one or more RFID transponders in a field by: providing a carrier signal; detecting the presence of at least one transponder; modifying the carrier signal in a predetermined manner, such as by sending out a continuous carrier signal; receiving data from all active transponders in the field; determining whether it has received a valid data transmission by checking the validity of each group of data as it is received; and upon determining an invalid data transmission, modifying the carrier signal—such as by suppressing the signal for a predetermined number of clock cycles—to inform all active transponders in the field that there was an incomplete read. The step of modifying the carrier signal is performed prior to the transponder sending its complete data transmission and it is performed substantially simultaneously upon the determination that invalid data transmission has been received. The interrogator iteratively repeats the steps of receiving data and determining whether it has received valid data, until the interrogator determines that it has read the complete data for each transponder in the field. The step of determining that the interrogator has received an invalid data transmission comprises detecting the interrogator's inability to compute a proper synchronization word, a proper CRC, or a proper word length. After determining that the interrogator has received complete data transmission by determining that the CRC is valid, the carrier signal is modified in a predetermined manner, such as by suppressing the signal for a predetermined number of clock cycles. The complete data for each transponder is transmitted from the interrogator to a computer system for processing.

BRIEF DESCRIPTION OF THE DRAWINGS

The invention will be explained in detail with reference to an example of the embodiment with the aid of the drawings as follows:

FIG. 1 is a block diagram of a passive RFID system.

FIG. 2 is a block diagram of an RFID interrogator.

FIG. 3 is a block diagram of a passive RFID transponder.

FIG. 4 is a flow chart of the sequence of events that occur within the transponder during collision resolution.

FIG. 5 is a flow chart of the sequence of events that occur within the interrogator during collision resolution.

FIG. 6 is a timing diagram showing clock waveforms from the interrogator.

DETAILED DESCRIPTION OF THE INVENTION

Passive, read-only RFID systems are well known in the art and only a brief overview of an RFID system will be given here for reference purposes. Referring to FIG. 1, a passive, read-only RFID system consists of an interrogator **10** and a transponder **20**. The interrogator provides a carrier signal **12** necessary for powering and synchronizing the transponder **20**, and receives modulated data **22** transmitted from the transponder **20**. The interrogator **10** decodes the data from the transponder **20**, verifies that the modulated transponder data **22** is valid, and sends this data to a computer system, not shown, for processing.

The interrogator **10** may be connected to a series circuit **11** that is resonant at the desired carrier frequency, or it may be connected to an antenna, depending upon frequency of operation and the desired communications method between the interrogator **10** and the transponder **20**.

The transponder **20**, in one embodiment, consists of a parallel resonant LC circuit **21**. In general, this circuit is resonant at the carrier frequency of the interrogator **10**; however, it could be configured such that the resonant frequency changes as a function of the transmitted data; or multiple resonant circuits could be utilized to optimize both power reception (resonance at the carrier frequency) and optimize signal strength from the transponder (resonance at the return frequency from the transponder).

Likewise, multiple antennas could be used for the same purpose.

Referring to FIG. 2, a block diagram of a typical RFID interrogator is given. The main components of the interrogator are the microcontroller **18**, amplifier and filter **16**, demodulator and drivers **14** and I/O circuitry **19**.

The microcontroller **18** contains firmware and the necessary I/O lines to provide proper operation of the interrogator. The microcontroller **18** generates a frequency that corresponds to the carrier frequency of the system. For low frequency transponders, this frequency is from the range of 100 kHz to 13.56 MHz. This frequency is filtered to generate a relatively harmonic free sine wave. This sine wave signal is buffered by the driver and demodulator block **14** to provide increased current drive capability. The output of the drivers circuit, not shown, is connected to the series LC circuit **11**. The nature of a series resonant circuit driven at the resonant frequency is such that the impedance of the circuit approaches the series resistance of the inductance in the circuit, and the voltage amplitude across the inductor and the capacitor increases to a large magnitude, far in excess of the applied voltage across the series LC circuit.

This large amplitude voltage across the inductor is the carrier referred to in this invention and is necessary to provide sufficient power to the transponder at substantial distances from the interrogator.

The carrier signal **12** is radiated without any underlying information being transmitted, and when a transponder **20** is placed within the field of the interrogator **10**, the carrier signal **12** is magnetically coupled to the parallel resonant circuit **21** within the transponder **20**. When the transponder **20** is moved to a certain distance from the reader, sufficient power will be applied to the transponder **20** to allow it to begin transmitting its data back to the interrogator **10** by reflecting a load across the magnetically coupled medium.

This reflected load will cause the amplitude of the carrier frequency to vary slightly, and these variations in the carrier

frequency are detected by the demodulator **14**. This method of communications is well known and some of the earlier work is described in U.S. Pat. No. 1,744,036 and U.S. Pat. No. 4,333,072, which are hereby incorporated by reference.

The output of the demodulator **14** will consist of the raw encoded data from the transponder **20** as well as a very large component of the carrier frequency and its harmonics. Consequently, it is necessary to provide filtering of this signal. The amp & filter block **16** perform this function. This amp & filter block **16** provides a bandpass filter which allows the signal components to pass but the carrier frequency and its harmonics are sufficiently suppressed. The resultant signal is amplified to provide proper signal levels for the microcontroller **18**. In one embodiment, the output of the amp & filter **16** is connected directly to the microcontroller **18**.

The microcontroller **18** executes a routine whereby the data from the amp & filter **16** is decoded into the proper logical states, and an error detection routine is executed, whereby, the data received and decoded is determined to be valid or invalid. If the data is valid, the data is sent to a host computer through the I/O block **19**. If the data is determined to be invalid, the interrogator **10** ignores the received data and continues processing data from the tag. In other embodiments, and specifically for anti-collision features, the reader determines that invalid data should be construed as a collision of data from multiple transponders **20**, and the reader suppresses a number of carrier clocks in addition to ignoring the received data from the transponder(s) **20**. The need for clock suppression will be explained in detail when the anti-collision invention is discussed.

Referring to FIG. 3, a passive RFID transponder block diagram is shown. The main function blocks are given as: rectifier **22**, regulator **23**, clock generator **25**, timing **26**, modulator **28**, anti-collision arbitrator **29**, control logic and state machine **27**, and memory **30**. The memory **30** includes: row address **34**, column address and sense amplifiers **32**, and memory array **36**.

The rectifier **22** is typically a full-wave rectifier which converts the AC carrier signal to a DC voltage. The rectifier **22** may also contain clamping diodes or an automatic gain control circuit to prevent an over-voltage condition when the interrogator is placed in close proximity to the transponder coil.

The regulator **23** controls the amplitude of the DC voltage from the rectifier **22** and provides a stable operating voltage for the transponder **20**. The regulator **23** may also contain a power-on-reset circuit which prevents the transponder from beginning operation or transmitting data before there is sufficient voltage available for proper operation.

The clock generator **25** performs signal conditioning on the carrier signal to provide a square wave clock signal for turning purposes. Additionally, "glitch" suppression and clock overlaps are eliminated by this circuitry. Another function performed by this circuitry is the detection of missing clocks from the carrier signal. This function will be explained in detail in the section describing the anti-collision function.

The modulator block **28** provides the proper encoding of data and generation of the signals to be transmitted to the interrogator.

The anti-collision arbitrator **29** controls the performance of the transponder **20** when collisions between tags is detected. The anti-collision arbitrator **29** also assigns a random address to the transponders **20** and controls the timing of the data to be transmitted to the interrogator **10**. This section will be discussed in detail in subsequent paragraphs.

The row address block **34** is used to address the rows within the memory array **36**.

The column address and Sense Amplifier block **32** contains logic addresses for each column within the memory array **36** and also contains the sense amplifier to determine the logic state of the specific bit in the array that is being addressed.

The control logic and state machine block **27** executes a specific routine which ensures that proper synchronization data, stored data in the array and Cyclic Redundancy Check (CRC) codes are sent in the proper sequence to the interrogator. This block also inhibits further transmission of data from the transponder **20** once it has been determined that transponder **20** has successfully transmitted its data.

The timing **26** block provides the proper timing for the desired data rate from the transponder. Additionally, the timing **26** block may provide the necessary signals for synchronization with the interrogator.

The memory array **36** stores the unique identification code in a read-only transponder **20**, and stores identification and user programmable data in a read/write transponder **20**.

Referring to FIG. **4** and FIG. **5**, flow charts for the operation of the interrogator **10** and the transponder **20**, respectively, are shown. During normal operation of the system, the interrogator **10** is sending out a carrier signal **12** for example a 125 kHz sine wave, for a first predetermined number of clock cycles. The interrogator **10** then suppresses the carrier signal **12** for a second predetermined number of clock cycles. This sequence continues until one or more transponders **20** are detected. The detection of transponders **20** is accomplished by detecting data from the demodulator in the interrogator **10**. Once the interrogator **10** detects the presence of transponder(s) **20**, the interrogator **10** begins sending out the carrier signal **12** continuously until a collision is detected. Collisions can be detected by the Microcontroller's **18** inability to resolve whether the received data from the AMP & FILTER **16** is a logic '1' or a logic '0'.

If a collision is detected, the interrogator **10** will suppress the carrier signal **12** for a second predetermined period of clocks and then begin transmitting a first predetermined period of clocks. This cycle continues until data from a transponder **20** is detected.

Again, when data from a transponder **20** is detected, the interrogator **10** transmits a continuous carrier signal **12** and processes the data received from the transponder **20**.

Other conditions that denote the presence of multiple transponders **20** is the inability to compute a proper synchronization word, inability to compute a proper CRC or improper word length. For example, a person with ordinary skill in the art would recognize that a possible word length is **96** bits, but the invention is not limited by the length of the data word. It is therefore advantageous for the interrogator to examine the received data to determine that it has a proper synchronization word, a proper CRC, and a proper word length. The failure of any of these conditions, may be treated as a collision, as discussed above.

Once the interrogator **10** has determined that it has received the full data word of the proper length, and the CRC is computed correctly, the interrogator will suppress the carrier signal **12** for the second predetermined number of clock periods. It is now necessary to refer to the transponder flow chart, FIG. **4**, to understand the difference in behavior of the transponder **20** due to when carrier signal **12** is suppressed for the second predetermined number of clock periods.

When a transponder **20** is sufficiently powered by the interrogator **10**, it resets the circuitry within the transponder

to a known state. Specifically, it sets the anti-collision arbitrator **29** to the 'transmit armed' state. The transponder does not transmit data, it merely waits until it determines that the carrier signal **12** has been suppressed for a predetermined number of clock periods. When the transponder **20** determines that the interrogator **10** is again sending a carrier signal **12** after the suppression for a predetermined number of clock periods, and the transponder **20** determines that it is in the 'transmit armed' state, it begins to execute a sequence of commands that will cause data from the memory array **26** to be modulated and transmitted to the interrogator **10**.

If, due to the conditions previously discussed when describing the interrogator flow chart a collision is detected and the interrogator suppress the carrier signal **12** for a second period, the transponder **20** will determine that a suppression of clocks has occurred and, if the full-cycle flag has not been set, the transponder **20** will cease transmitting its data. Concurrently, the transponder **20** will load a new number into its address register. Preferably, this will be a random number.

As previously described, the interrogator **10** will continuously cycle through generation of clocks for a first predetermined amount of time and suppression of clocks for a second predetermined amount of time.

Each time the interrogator **10** suppresses the carrier signal **12** for a second predetermined number of clock cycles, the address is decremented by one count. Alternatively, the count may be increased or decreased by a different number of cycles, each address in each transponder **20** is altered. When a transponder **20** has its address reach a preset critical value, the anti-collision arbitrator **29** is set to 'transmit armed' state and the transponder **20** begins to transmit its data. Preferably, the critical value is when the address is zero.

If no collisions are detected, the transponder **20** will transmit its full cycle and the interrogator **10** will send out a continuous carrier signal **12** until it verifies that all data has been properly received.

Likewise, for the other transponders **20** in the field, the detection of missing clocks causes their addresses to be altered, and preferably decremented. This cycle continues until another transponder **20** has a address of the critical value and the anti-collision arbitrator changes 'transmit armed' state, at which time the transponder **20** begins to transmit its data.

If more than one transponder **20** has their address as the critical value, the reader detects the collision and stops the clocks for a second predetermined number of cycles. At that time, only the transponders **20** with an address of the critical will recompute their addresses, preferably with a random number.

The operation of a specific embodiment is described in FIG. **4** which is a flow chart outlining the process steps for the transponder **20**. The transponder **20** enters the field generated by the interrogator **10** and resets **100** by setting itself to the transmit-armed state and by removing the full-cycle flag. The number in memory **30** is set to zero and modulation is turned off **105**. The transponder **20** detects the presence of an interrogator by checking **110** whether the transponder **20** sees modification of the carrier signal in a predetermined manner, which for this embodiment is carrier signal **12** loss. The transponder **20** iteratively keeps checking until the transponder **20** sees a loss and then determines whether the number in memory **30** satisfies the transmission criteria. In the embodiment described in FIG. **4**, the tran-

ponder 20 determines whether the number in memory 30 is equal to zero 115 to satisfy the transmission criteria. If the number in memory 30 does not satisfy the transmission criteria which for this embodiment the number would not equal zero, then the number is modified. For this embodiment, modification is achieved by decrementing the number 120 and then returning to the iterative process of checking to determine whether there is any carrier signal loss 110. If the number in memory 30 equals zero, then the random number generator is turned on until the next loss of carrier 125. The transponder 20 modulates the data to the interrogator 10 after waiting four bit periods 130. The transponder 20 iteratively determines whether it has waited four bit periods 135 and if so, modulation occurs on the first data bit.

The transponder 20 transmits the data one bit at a time 140, starting with the first data bit. The transponder 20 then iteratively determines whether the carrier signal 12 has been modified in a predetermined manner, which in this embodiment is the determination 145 of whether the transponder 20 sees any carrier signal 12 loss. If the transponder 20 determines that there is a loss in the carrier signal 12, then the transponder 20 detects a collision and the random number generator generates a new number, the random number generator is turned off 180, and the transponder 20 iteratively determines whether there is any carrier signal loss 110.

If the transponder 20 determines that there is no carrier loss after transmitting the data bit 145, then the transponder 20 determines whether the last data bit has been sent (complete data transmission), which in this embodiment would require the determination of whether the 96th data bit had been sent 150. If the last data bit has not been sent, then the next data bit is transmitted 140 to the interrogator 10. If the transponder determines that the last data bit has been sent, then the transponder 20 sets the full-cycle flag 155.

After setting the full cycle flag, the transponder 20 transmits the first data bit 160 to the interrogator 10. The transponder 20 then iteratively determines whether the carrier signal 12 has been modified in a predetermined manner, which in this embodiment is the determination 165 of whether the transponder 20 sees any carrier signal 12 loss. If the transponder 20 determines that there is no carrier loss, then the transponder 20 iteratively transmits 160 the next bit of data.

If the transponder 20 determines that there is a loss in the carrier signal 12, then the transponder 20 determines 175 whether the first bit was just transmitted and whether the full-cycle flag is set. If the data is not the first data bit then the transponder iteratively transmits 160 the next data bit. If the full-cycle flag has not been set and the data is the first bit, then the transponder 20 detects an error and the random number generator generates a new number, the random number generator is turned off 180, and the transponder 20 iteratively determines whether there is any carrier signal loss 110.

If the transponder 20 determines 175 that the first data bit has been sent and the full-cycle flag is set, then the transponder 20 determines that the interrogator 10 has read the complete data set and the transponder 20 goes dormant 190.

An embodiment is described in FIG. 5, which shows the process steps for the interrogator 10. The interrogator 10 is powered up 200 and immediately begins transmitting 205 the carrier signal 12. The interrogator 10 looks 215 for transponders 20 during the first predetermined period 210 and if the interrogator 10 does not detect 215 a transponder

20, the interrogator 10 suppresses 270 the carrier signal 12 for a second predetermined period to signal a new tag or transponder 20 to transmit or to sync colliding tags. The interrogator 10 next determines 275 whether the period is complete and continues to suppress 280 the carrier signal 12 until the interrogator determines 275 that the period done, in which case, the interrogator 10 turns on 285 the carrier signal 12. The interrogator 10 then repeats the process and looks 210 for transponders 20 during the first predetermined period. If the interrogator 10 detects 215 the presence of a transponder 20, the interrogator 10 leaves the carrier signal 12 on until it receives 220 invalid data due to a collision or error.

The interrogator 10 reads 225 the first bit of data, looking for a sync word. The interrogator 10 iteratively determines 230 whether each bit of data is good and if the data bit is bad, the interrogator 10 detects a collision and suppresses 270 the carrier signal 12 for a second predetermined period to signal a new tag or transponder 20 to transmit or to sync colliding tags. The interrogator 10 next determines 275 whether the period is complete and continues to suppress 280 the carrier signal 12 until the interrogator determines 275 that the period done, in which case, the interrogator 10 turns on 285 the carrier signal 12. The interrogator 10 then repeats the process and looks 210 for transponders 20 during the first predetermined period. If the interrogator 10 determines 230 that each data bit is good, at the eleventh bit, the interrogator 10 determines whether the sync word is valid and if the sync word is invalid, the interrogator 10 detects an error and suppresses 270 the carrier signal 12 for a second predetermined period to signal a new tag or transponder 20 to transmit or to sync colliding tags. The interrogator 10 next determines 275 whether the period is complete and continues to suppress 280 the carrier signal 12 until the interrogator determines 275 that the period done, in which case, the interrogator 10 turns on 285 the carrier signal 12. The interrogator 10 then repeats the process and looks 210 for transponders 20 during the first predetermined period.

If the interrogator 10 determines 240 that the sync word is valid, the interrogator 10 continues to read 245 each data bit to obtain data and the CRC. The interrogator 10 determines 250 whether each data bit is valid and if the data is bad, the interrogator 10 detects a collision and the interrogator 10 suppresses 270 the carrier signal 12 for a second predetermined period to signal a new tag or transponder 20 to transmit or to sync colliding tags. The interrogator 10 next determines 275 whether the period is complete and continues to suppress 280 the carrier signal 12 until the interrogator determines 275 that the period done, in which case, the interrogator 10 turns on 285 the carrier signal 12. The interrogator 10 then repeats the process and looks 210 for transponders 20 during the first predetermined period.

If the interrogator 10 determines 250 that the data bit is good, the interrogator 10 iteratively continues to read the next data bit until the interrogator 10 determines 255 that it has read the ninety-sixth data bit, wherein the interrogator 10 computes 260 the CRC and tests. If the interrogator 10 determines 265 that the CRC is not good, then the interrogator 10 detects a collision and the interrogator 10 suppresses 270 the carrier signal 12 for a second predetermined period to signal a new tag or transponder 20 to transmit or to sync colliding tags. The interrogator 10 next determines 275 whether the period is complete and continues to suppress 280 the carrier signal 12 until the interrogator determines 275 that the period done, in which case, the interrogator 10 turns on 285 the carrier signal 12. The interrogator 10 then repeats the process and looks 210 for transponders 20 during the first predetermined period.

If the interrogator determines **265** that the CRC is good, then the interrogator **10** suppresses **290** the carrier signal **12** for a second predetermined period when the interrogator **10** reads the first data bit in order to signal to the transponder **20** that it was read. The interrogator **10** next determines **295** 5 whether the period is complete and continues to suppress **300** the carrier signal **12** until the interrogator determines **295** that the period is done, in which case, the interrogator **10** turns on **305** the carrier signal **12** and processes **310** the transponder code. The interrogator **10** then repeats the process and looks **210** for transponders **20** during the first predetermined period.

An example of the anti-collision timing is shown in FIG. **6**. The carrier signal **12** sent by the interrogator is represented pictorially by **420**, wherein the signal interrupts are shown as square wave pulses in **425**. The interrogator **10** or reader sends **400** interrupts and bursts to look for tags or transponders **20**. The first tag is within the reader's field upon the end of the suppression of the carrier signal **12** at position **400**, the transponder **20** and the reader detects **400** the presence of the first tag and transmits the carrier signal continuously. The first tag transmits its data **430** to the reader.

The reader reads the first tag, waits till the first bit is repeated for the first tag and sends an interrupt at time position **405** which starts the second **440** and third **450** tags transmitting. The reader detects the collision and sends an interrupt at time position **410**. The reader continues to send interrupts and bursts at time position **415** looking for tags. When the reader detects the presence of the second tag, it sends a continuous carrier signal while reading the tag. Because the second tag generated a random number of three, the tag transmits its data on the third interrupt **445**. Similarly, the third tag generated a random number of four and it sends its data after waiting one more time slot on the fourth interrupt **455**.

The present invention has been described above with reference to a preferred embodiment. However, those skilled in the art will recognize that changes and modifications may be made in this embodiment without departing from the scope of the present invention. Those skilled in the art will recognize that the various specific tasks and devices described herein in connection with this embodiment may be altered significantly without departing from the scope of the present invention. These and other changes and modifications which are obvious to those skilled in the art are intended to be within the scope of the present invention.

What is claimed is:

1. A method for an interrogator reading one or more RFID transponders in a field comprising the steps of:

- a. providing a carrier signal;
- b. detecting the presence of at least one transponder;
- c. receiving data from all active transponders in the field;
- d. determining whether the interrogator has received a valid data transmission; and
- e. upon determining an invalid data transmission, informing all active transponders in the field that there was an incomplete read, the informing including suppressing the carrier.

2. The method recited in claim **1**, wherein steps (c) and (d) are iteratively repeated until the interrogator determines that it has read the complete data for each transponder in the field.

3. The method recited in claim **2**, further comprising the step of transmitting the complete data for each transponder from the interrogator to a computer system for processing.

4. The method recited in claim **2**, wherein the interrogator includes a demodulator and the step of detecting the presence of one or more transponders comprises receiving data from the demodulator and modifying the carrier signal in a predetermined manner.

5. The method recited in claim **4**, wherein the step of modifying the carrier signal in a predetermined manner comprises sending out the carrier signal continuously.

6. The method as recited in claim **2**, wherein the step of determining whether the interrogator has received an invalid data transmission comprises detecting the interrogator's inability to compute a proper synchronization word, a proper CRC, or a proper word length.

7. The method as recited in claim **2**, wherein the step of informing active transponders in the field that there was an incomplete read comprises suppressing the carrier signal for a predetermined number of clock cycles.

8. The method as recited in claim **2**, wherein the step of informing active transponders in the field that there was an incomplete read is performed prior to the transponder sending its complete data transmission.

9. The method as recited in claim **8** wherein the step of informing active transponders in the field that there was an incomplete read is performed substantially simultaneously upon the determination that invalid data transmission has been received.

10. The method as recited in claim **2**, wherein the receiving step comprises receiving the data in groups of one or more bits and checking the validity of each group of data as it is received.

11. The method as recited in claim **2**, wherein the step of determining complete data transmission comprises determining that the CRC is valid and modifying the carrier signal in a predetermined manner.

12. The method as recited in claim **9**, wherein step of modifying the carrier signal in a predetermined manner comprises suppressing the carrier signal for a predetermined number of clock cycles.

13. A method for an interrogator reading one or more RFID transponders in a field, the interrogator including a demodulator, the method comprising:

- providing a carrier signal;
- detecting the presence of at least one transponder, the detecting including receiving data from the demodulator and modifying the carrier signal by suppressing the carrier signal for a predetermined number of clock cycles;

receiving data from all active transponders in the field, the receiving including receiving the data in groups of one or more bits and checking the validity of each group of data as the group is received;

determining whether the interrogator has received a valid data transmission by detecting the interrogator's inability to compute a proper synchronization word, a proper CRC, or a proper word length;

upon determining an invalid data transmission, modifying the carrier signal to inform all active transponders in the field that there was an incomplete read; and

transmitting the complete data for each transponder from the interrogator to a computer system for processing.

14. The method as recited in claim **13**, wherein the step of modifying the carrier signal is performed prior to the transponder sending its complete data transmission.

15. The method as recited in claim **13** wherein the step of modifying the carrier signal is performed substantially simultaneously upon the determination that invalid data transmission has been received.

11

16. The method as recited in claim 13 wherein the receiving and the determining whether the interrogator has received a valid data transmission are iteratively repeated until the interrogator determines that the interrogator has read the complete data for each transponder in the field. 5

17. The method as recited in claim 16, wherein determining that the interrogator has read the complete data for one of the transponders in the field comprises determining that a CRC is valid and modifying the carrier signal in a predetermined manner. 10

18. A method for an interrogator reading one or more RFID transponders in a field, the interrogator including a demodulator, the method comprising:

providing a carrier signal;

detecting the presence of at least one transponder, the detecting including receiving data from the demodulator and modifying the carrier signal in a predetermined manner; 15

receiving data from all active transponders in the field, the receiving including receiving the data in groups of one or more bits and checking the validity of each group of data as it is received; 20

determining whether the interrogator has received a valid data transmission; the receiving and the determining being iteratively repeated until the interrogator determines that the interrogator has read complete data for each transponder in the field, the determining that the interrogator has read complete data for one of the 25

12

transponders including determining that the CRC is valid and suppressing the carrier;

upon determining an invalid data transmission, modifying the carrier signal to inform all active transponders in the field that there was an incomplete read; and

transmitting the complete data for each transponder from the interrogator to a computer system for processing.

19. The method recited in claim 18, wherein the step of modifying the carrier signal in a predetermined manner comprises sending out the carrier signal continuously. 10

20. The method as recited in claim 18, wherein the step of modifying the carrier signal in a predetermined manner comprises suppressing the carrier signal for a predetermined number of clock cycles. 15

21. The method as recited in claim 20, wherein the step of modifying the carrier signal is performed prior to the transponder sending its complete data transmission.

22. The method as recited in claim 20 wherein the step of modifying the carrier signal is performed substantially simultaneously upon the determination that invalid data transmission has been received. 20

23. The method as recited in claim 18, wherein the step of determining whether the interrogator has received an invalid data transmission comprises detecting the interrogator's inability to compute a proper synchronization word, a proper CRC, or a proper word length. 25

* * * * *

UNITED STATES PATENT AND TRADEMARK OFFICE
CERTIFICATE OF CORRECTION

PATENT NO : 5,986,570

DATED : November 16, 1999

INVENTOR(S) : Donald L. Black et al.

It is certified that error appears in the above-identified patent and that said Letters Patent is hereby corrected as shown below:

Col. 1, line 25
replace "issuing"
with --requiring--.

Col. 4, line 52
replace "turning"
with --timing--.

Col. 5, line 37
replace "will"
with --will--.

Col. 9, line 20
replace "trnspnder"
with --transponder--.

Signed and Sealed this
Twentieth Day of February, 2001

Attest:



NICHOLAS P. GODICI

Attesting Officer

Acting Director of the United States Patent and Trademark Office



US005986570C1

(12) **EX PARTE REEXAMINATION CERTIFICATE** (10414th)
United States Patent
Black et al.

(10) **Number:** US 5,986,570 C1(45) **Certificate Issued:** Nov. 24, 2014

(54) **METHOD FOR RESOLVING SIGNAL COLLISIONS BETWEEN MULTIPLE RFID TRANSPONDERS IN A FIELD**

USPC 340/10.2; 340/10.3; 340/10.42; 714/748; 714/749; 714/797; 714/799

(75) Inventors: **Donald L. Black**, Erie, CO (US); **Dale Yones**, Boulder, CO (US)

(58) **Field of Classification Search**

None

See application file for complete search history.

(73) Assignee: **Round Rock Research, LLC**, Mt. Kisco, NY (US)

(56) **References Cited****Reexamination Request:**

No. 90/011,898, Sep. 14, 2011

To view the complete listing of prior art documents cited during the proceeding for Reexamination Control Number 90/011,898, please refer to the USPTO's public Patent Application Information Retrieval (PAIR) system under the Display References tab.

Reexamination Certificate for:Patent No.: **5,986,570**Issued: **Nov. 16, 1999**Appl. No.: **08/922,491**Filed: **Sep. 3, 1997***Primary Examiner* — Albert J Gagliardi

Certificate of Correction issued Feb. 20, 2001

(51) **Int. Cl.****G06K 7/00** (2006.01)**G06K 7/10** (2006.01)(52) **U.S. Cl.**CPC **G06K 7/10039** (2013.01); **G06K 7/0008** (2013.01)(57) **ABSTRACT**

Communications between an RFID interrogator and an RFID transponder require that no more than one transponder be present in the reading range of the interrogator and transmitting into motion at any given time. If multiple transponders are in the field, then a collision between the return signals of the transponders occurs, rendering the signals unreadable. A method to resolve the collisions and allow for accurate transmission of each transponder's data is given. This method is especially effective over other methods when the transponder is a read-only type of device, whereby there is no communications interrogator on board the read-only transponder.

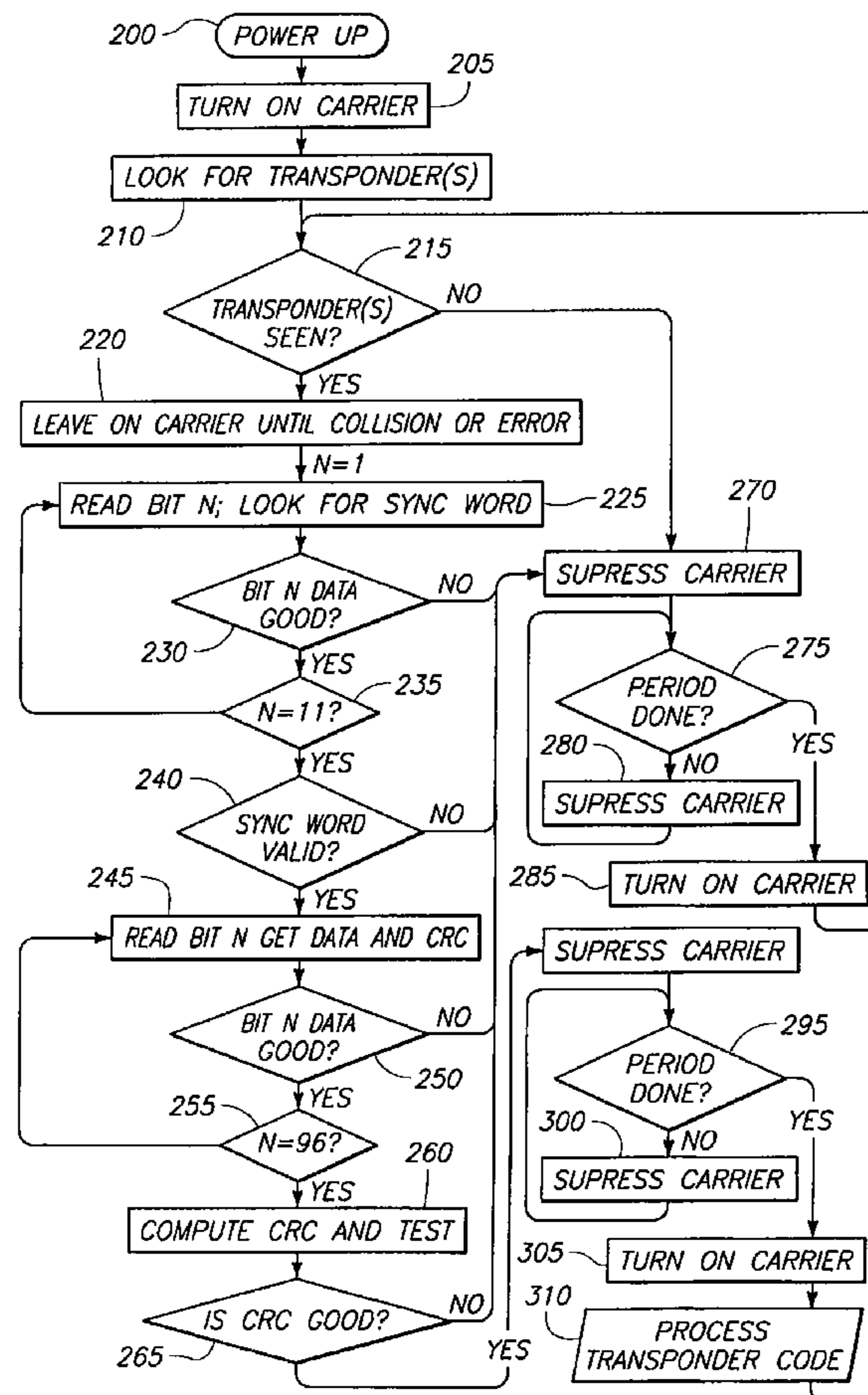

**EX PARTE
REEXAMINATION CERTIFICATE
ISSUED UNDER 35 U.S.C. 307**

THE PATENT IS HEREBY AMENDED AS
INDICATED BELOW.

5

AS A RESULT OF REEXAMINATION, IT HAS BEEN
DETERMINED THAT:

10

Claims **13** and **18** are cancelled.

Claims **1-12**, **14-17** and **19-23** were not reexamined.

* * * * *