



US005974651A

United States Patent [19]

[11] Patent Number: **5,974,651**

Weder

[45] Date of Patent: ***Nov. 2, 1999**

[54] **METHOD OF COVERING A FLOWER POT AND FLORAL GROUPING**

[75] Inventor: **Donald E. Weder**, Highland, Ill.

[73] Assignee: **Southpac Trust International, Inc.**

[*] Notice: This patent is subject to a terminal disclaimer.

2036163	12/1970	France .
2619698	3/1989	France .
345464	12/1921	Germany .
513971	11/1930	Germany .
8905250	10/1989	Germany .
560532	4/1975	Switzerland .
1204647	9/1970	United Kingdom .
2074542	11/1981	United Kingdom .
9315979	8/1993	WIPO .

OTHER PUBLICATIONS

[21] Appl. No.: **09/036,044**

[22] Filed: **Mar. 6, 1998**

Related U.S. Application Data

[63] Continuation of application No. 08/846,441, Apr. 30, 1997, Pat. No. 5,815,905, which is a continuation of application No. 08/468,502, Jun. 6, 1995, Pat. No. 5,625,937, which is a continuation of application No. 08/037,067, Mar. 25, 1995, Pat. No. 5,542,169, which is a continuation-in-part of application No. 07/926,098, Aug. 5, 1992, Pat. No. 5,809,629, and application No. 07/940,930, Sep. 4, 1992, Pat. No. 5,361,482.

[51] **Int. Cl.⁶ B21D 35/00**

[52] **U.S. Cl. 29/469.5; 29/469.5; 53/410**

[58] **Field of Search 29/505, 469.5, 29/515, 525; 47/72; 53/410**

[56] References Cited

U.S. PATENT DOCUMENTS

1,446,563	2/1923	Hughes .	
1,610,652	12/1926	Bouchard .	
1,868,853	7/1932	Sievers .	
1,988,886	1/1935	Wilson	47/37
2,152,648	4/1939	Jones	47/34
2,209,778	7/1940	Krasowski	41/10
2,302,259	11/1942	Rothfuss	41/10
2,621,142	12/1952	Wetherell	154/117
2,648,487	8/1953	Linda	229/55

(List continued on next page.)

FOREIGN PATENT DOCUMENTS

4231978 6/1979 Australia .

Color Them Happy With Highlander® Products, ©1922, 2 Pages.

Super Seller, Supermarket Floral, Sep. 15, 1992.

Costa Keeps the Christmas Spirit, Supermarket Floral, Sep. 15, 1992.

Now, More Than Ever, Supermarket Floral, Sep. 15, 1992.

Halloween, Link Magazine, Sep. 1992, 2 pages.

Speed Cover® Brochure—The Simple Solution . . . , ©1989.

Speed Sheets and Speed Rolls Brochure, ©1990.

Primary Examiner—S. Thomas Hughes

Assistant Examiner—Steven A Blount

Attorney, Agent, or Firm—Dunlap, Coddling & Rogers, P.C.

[57] ABSTRACT

A covering for a flower pot with a floral grouping disposed therein and extending a distance above an upper end of the flower pot wherein the flower pot has a lower end and an outer peripheral surface. The covering includes a sheet of material having an upper surface, a lower surface and an outer peripheral surface with a sheet extension connected to the outer peripheral surface of the sheet of material and extending a distance from the outer peripheral surface of the sheet of material. The sheet of material is formed about the flower pot to a position wherein the sheet of material extends about substantially the entire outer peripheral surface of the flower pot to provide a decorative covering and the sheet extension is formed about the floral grouping to a position wherein the sheet extension extends about a substantial portion of the floral grouping to provide a protective covering.

12 Claims, 10 Drawing Sheets

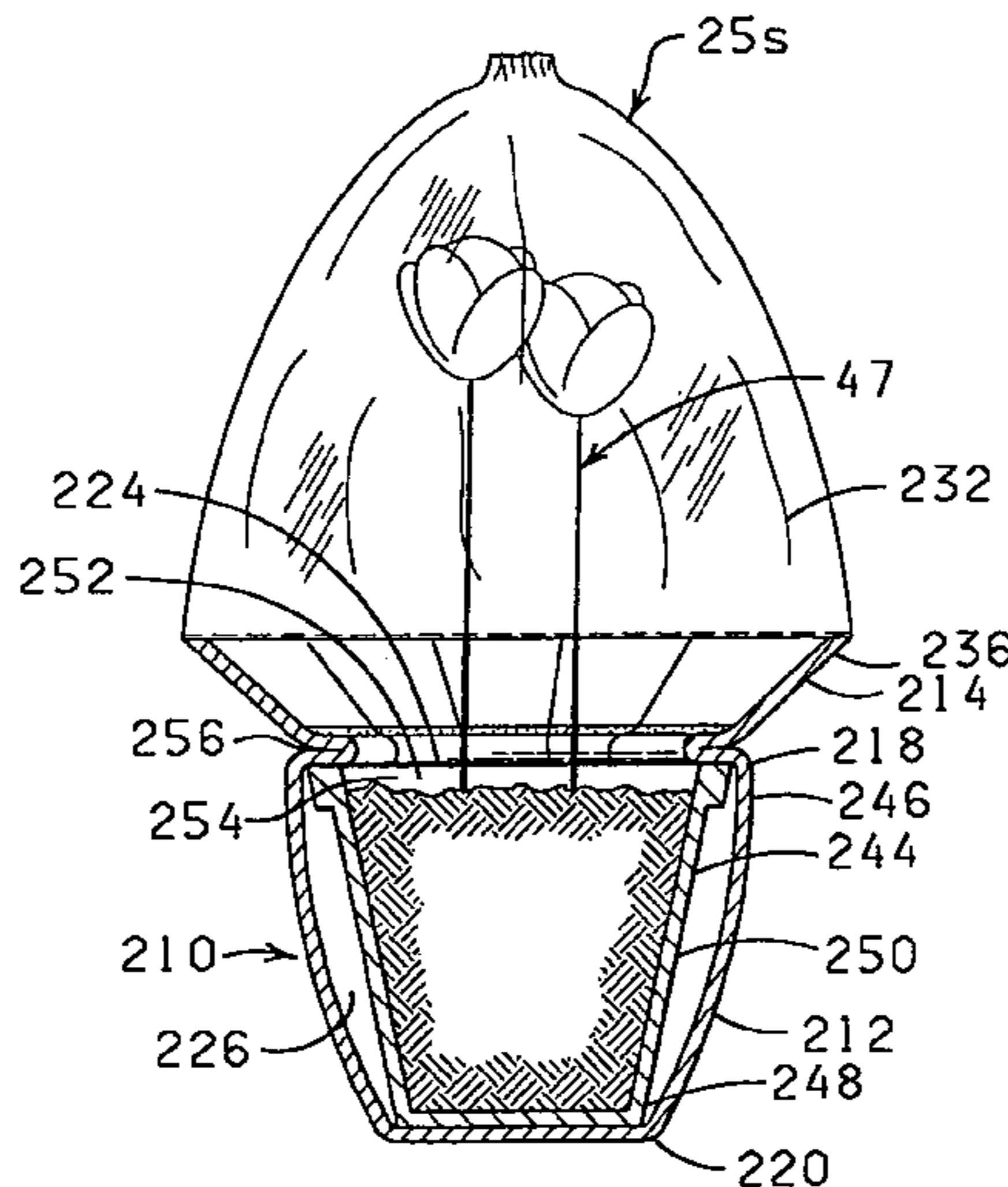

U.S. PATENT DOCUMENTS

2,774,187	12/1956	Smithers	47/41	4,733,521	3/1988	Weder et al.	53/580
2,850,842	9/1958	Eubank	47/58	4,773,182	9/1988	Weder et al.	47/72
3,022,605	2/1962	Reynolds	47/58	4,799,520	1/1989	Blackburn et al.	150/52
3,052,063	9/1962	Dunn	47/38	4,801,014	1/1989	Meadows	206/423
3,094,810	6/1963	Kalpin	47/37	4,941,572	7/1990	Harris	206/423
3,134,679	5/1964	Dreyfus	53/397	4,980,209	12/1990	Hill	428/34.1
3,271,922	9/1966	Wallerstein et al.	53/399	5,005,760	4/1991	van den Hoogen	229/125.38
3,316,675	5/1967	Cartwright	47/37	5,105,599	4/1992	Weder	53/399
3,431,706	3/1969	Stuck	53/390	5,111,638	5/1992	Weder	53/397
3,488,022	1/1970	Vittori	248/152	5,152,100	10/1992	Weder et al.	47/72
3,557,516	1/1971	Brandt	53/14	5,181,364	1/1993	Weder	53/397
3,616,197	10/1971	Amberg		5,199,242	4/1993	Weder et al.	53/397
3,962,503	6/1976	Crawford	53/397 X	5,205,108	4/1993	Weder et al.	53/397
4,333,267	6/1982	Witte	47/84	5,228,234	7/1993	de Klerk et al.	47/41.01
4,384,604	5/1983	DeLaura et al.	150/52	5,239,775	8/1993	Landau	47/72
4,413,725	11/1983	Bruno et al.	47/72 X	5,259,106	11/1993	Weder et al.	29/469.5
4,621,733	11/1986	Harris	206/423	5,353,575	10/1994	Stepanek	53/461
4,640,079	2/1987	Stuck	53/390	5,388,695	2/1995	Gilbert	206/423
				5,815,905	10/1998	Weder	.

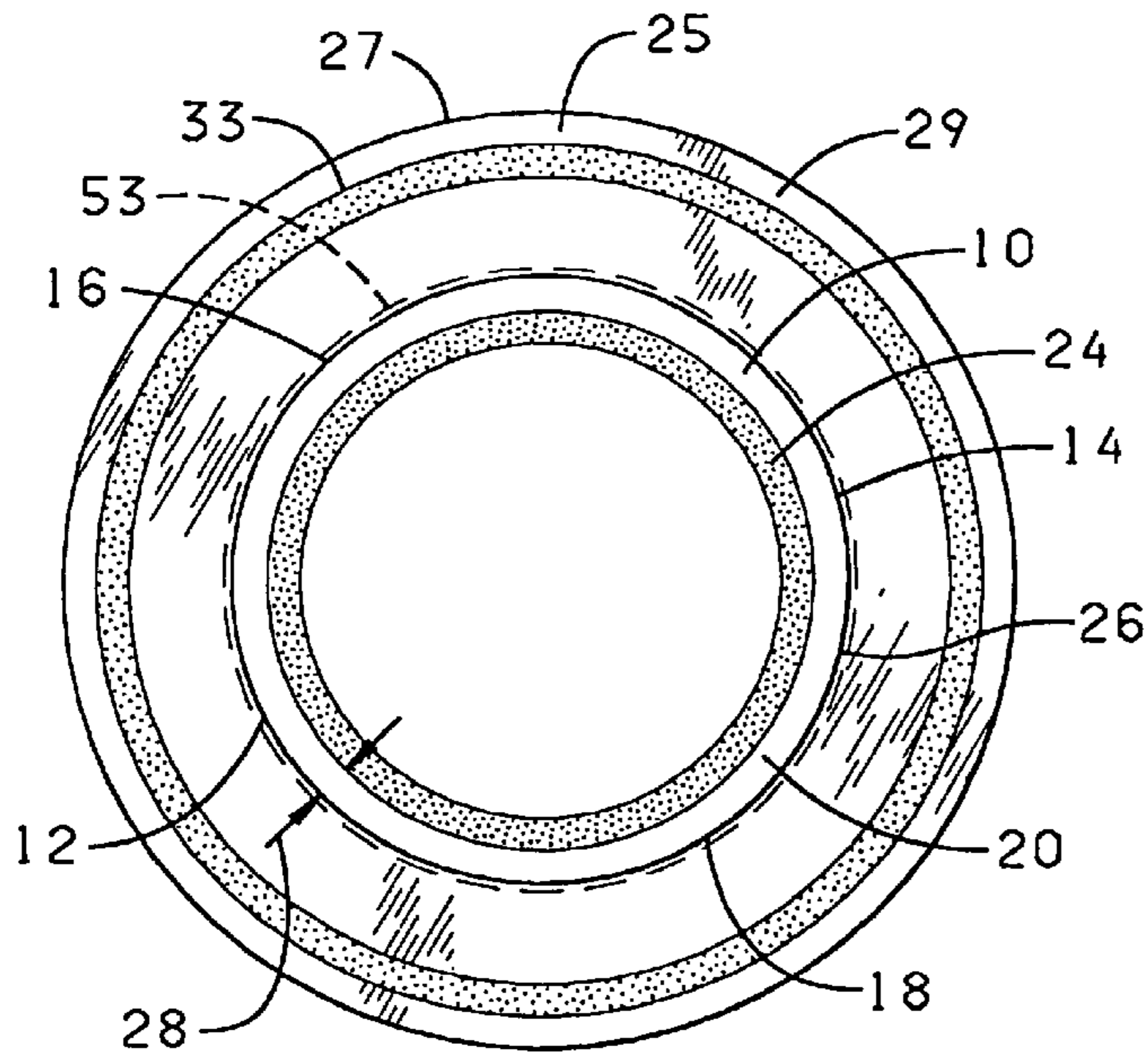

FIG. 1

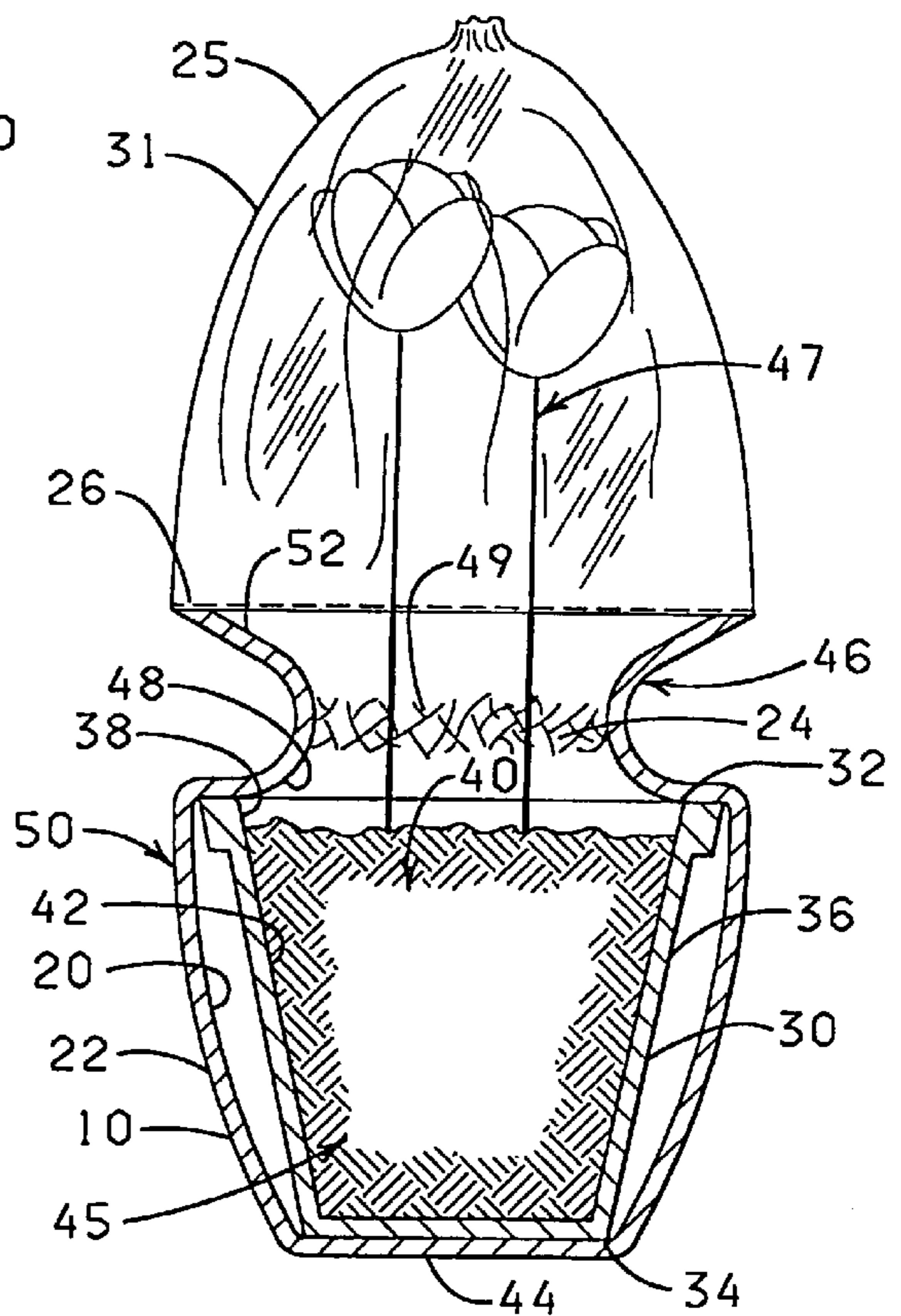

FIG. 2

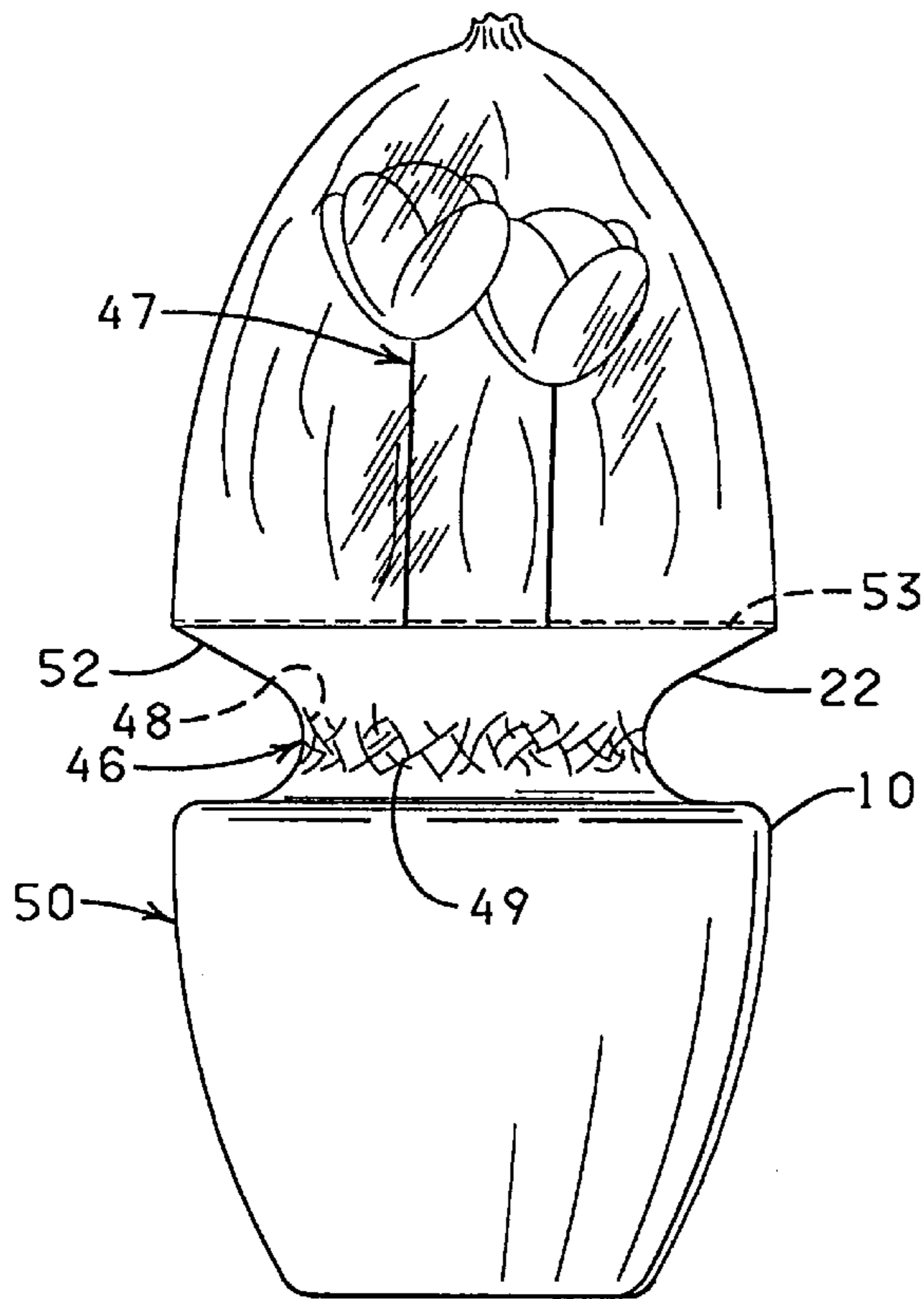

FIG. 3

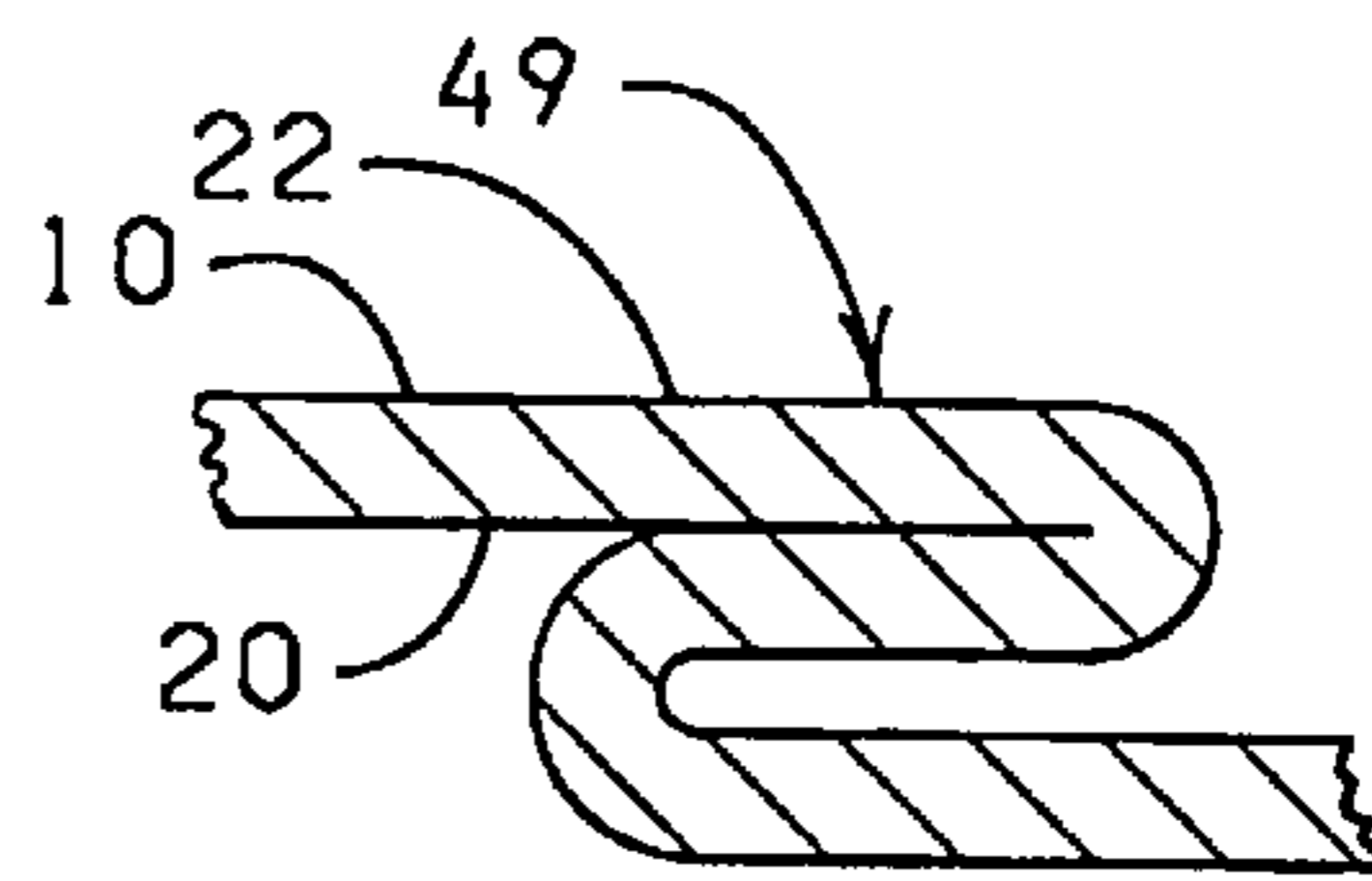

FIG. 4

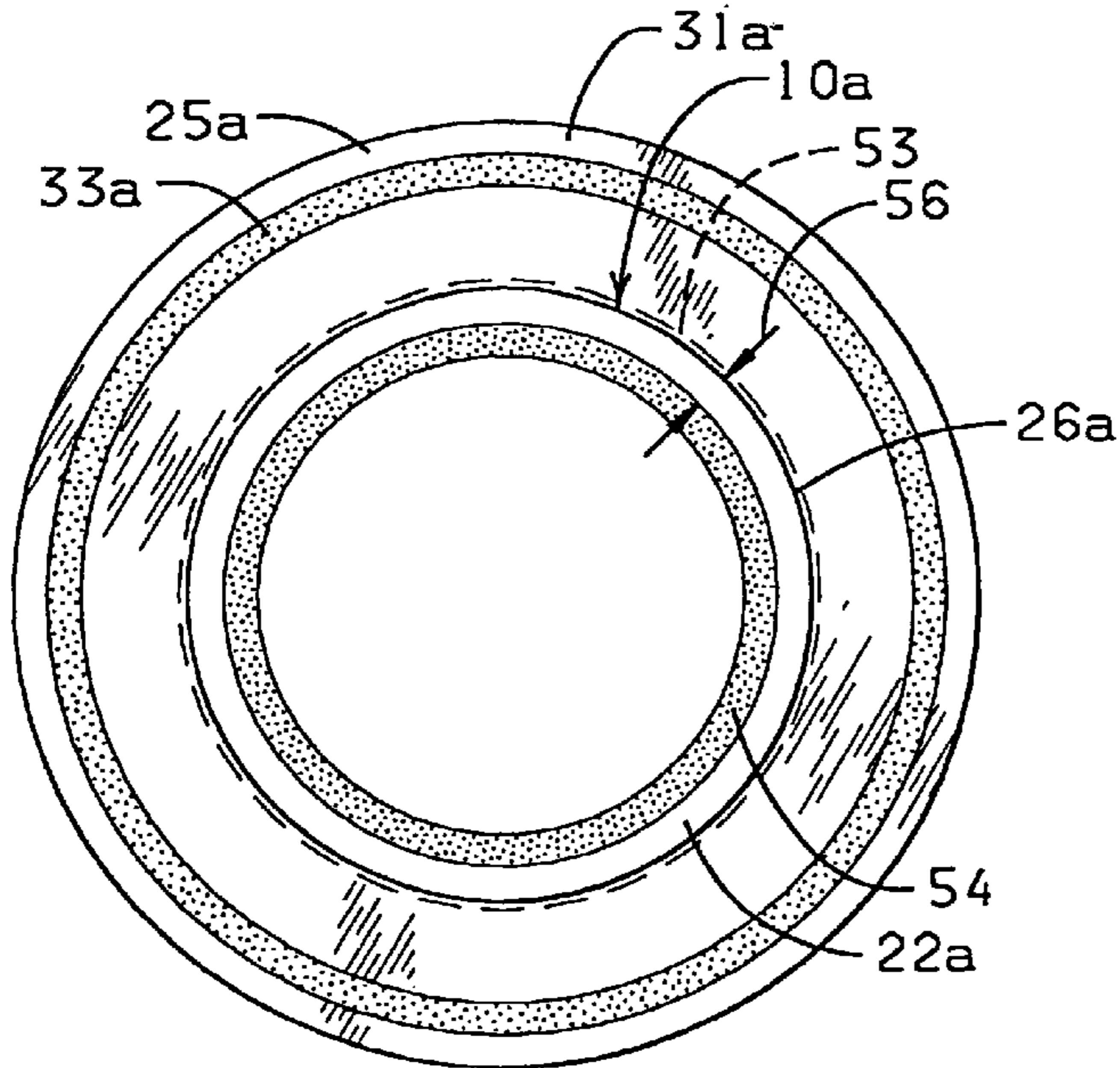

FIG. 5

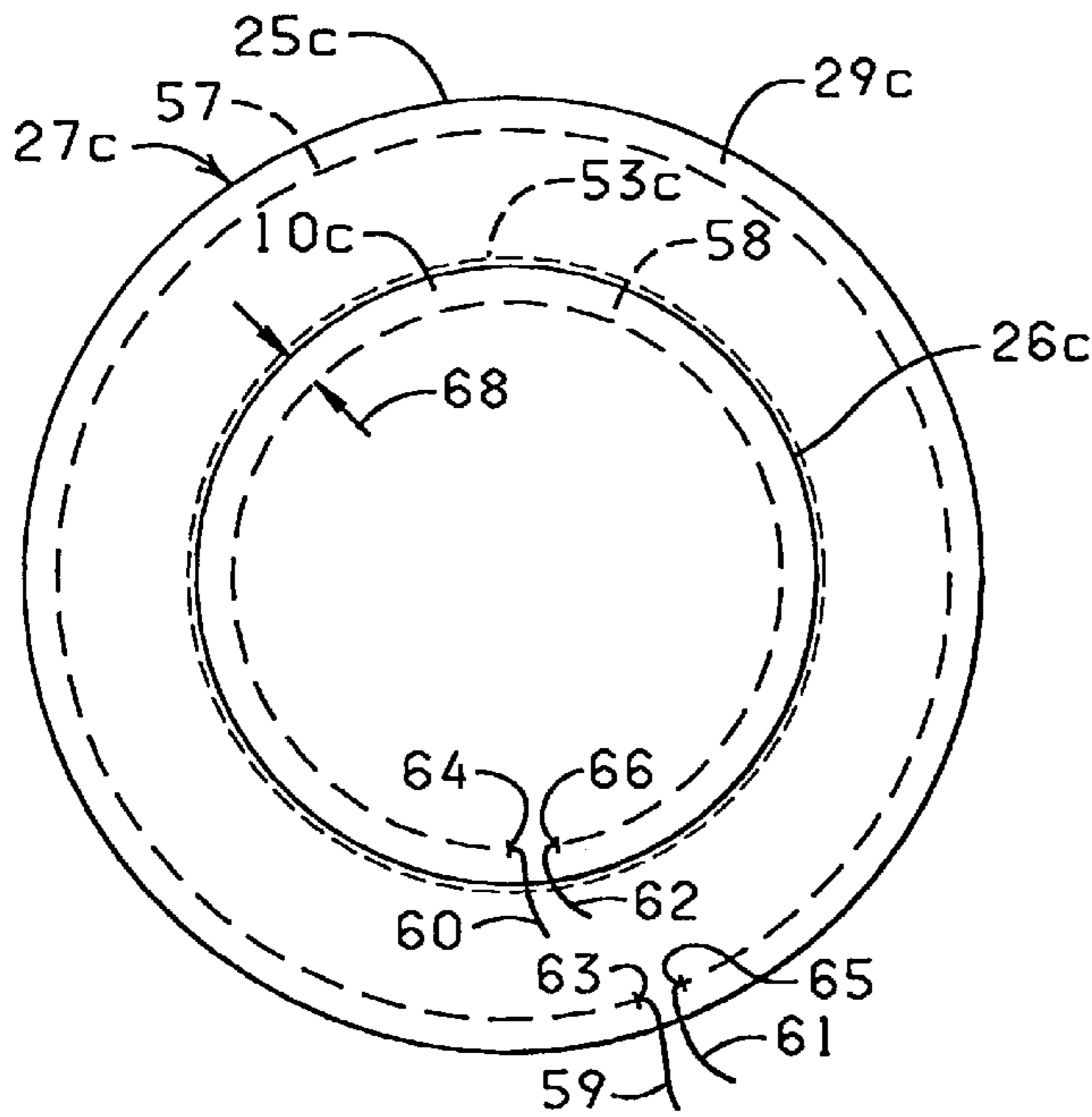
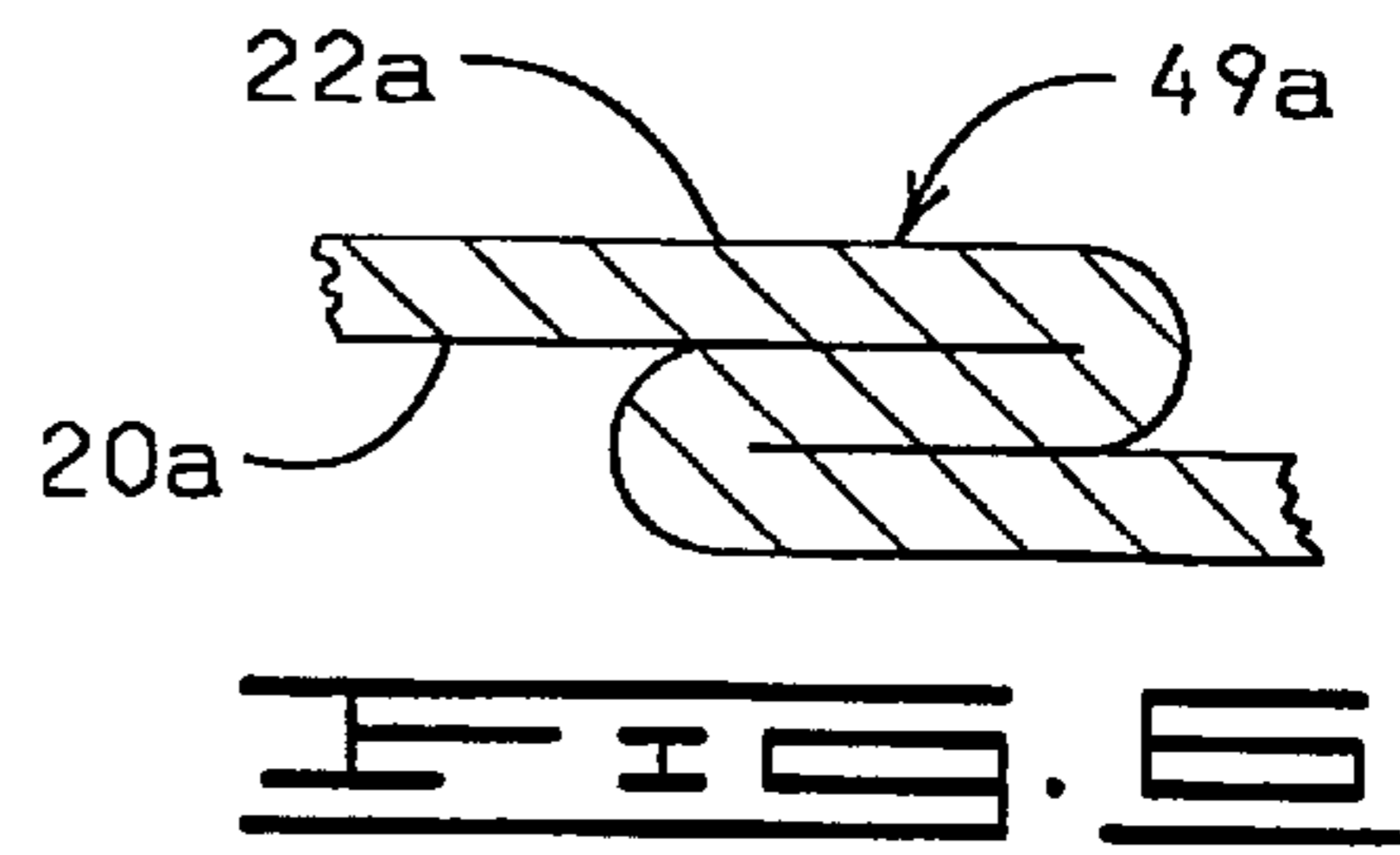

FIG. 7

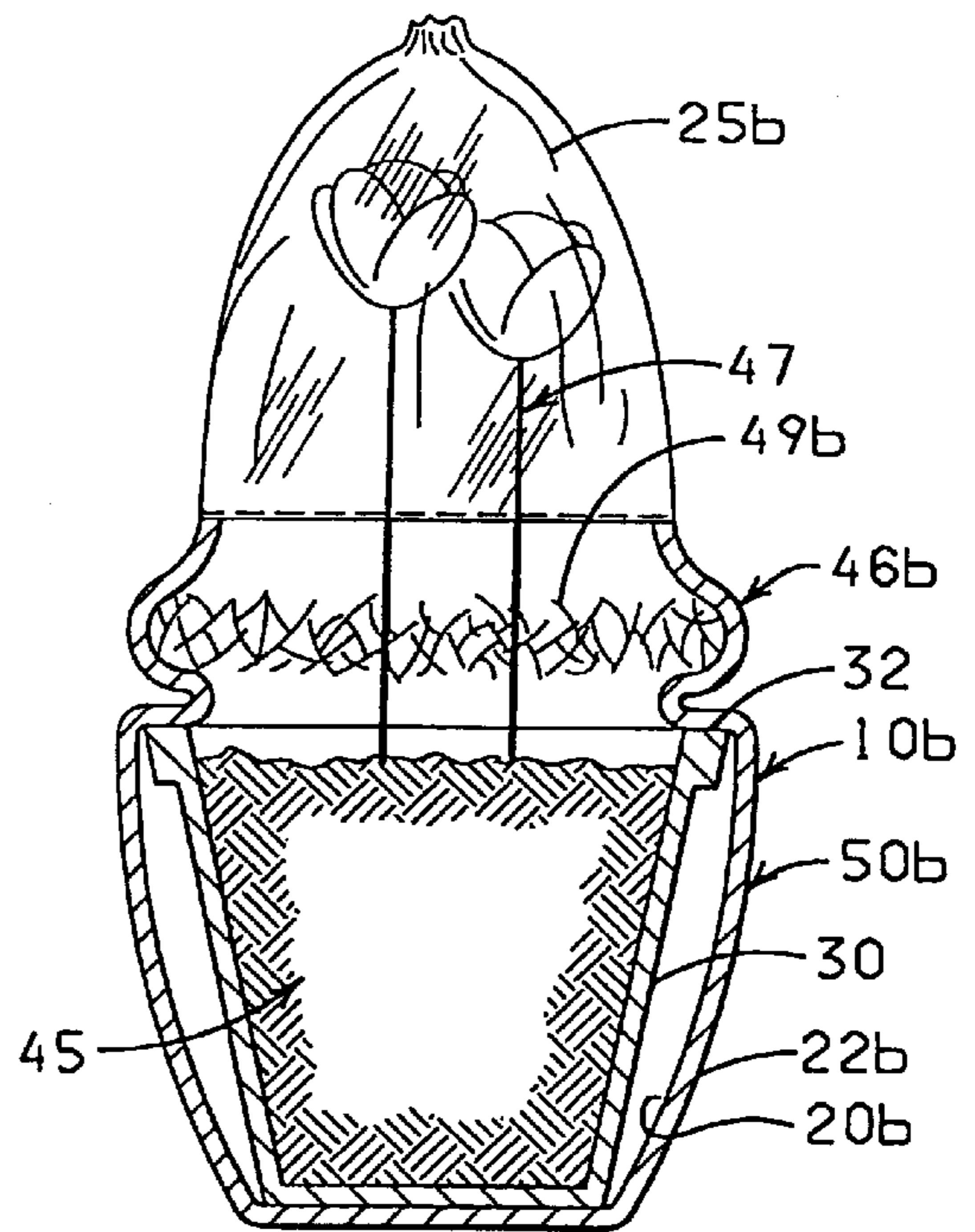

FIG. 8

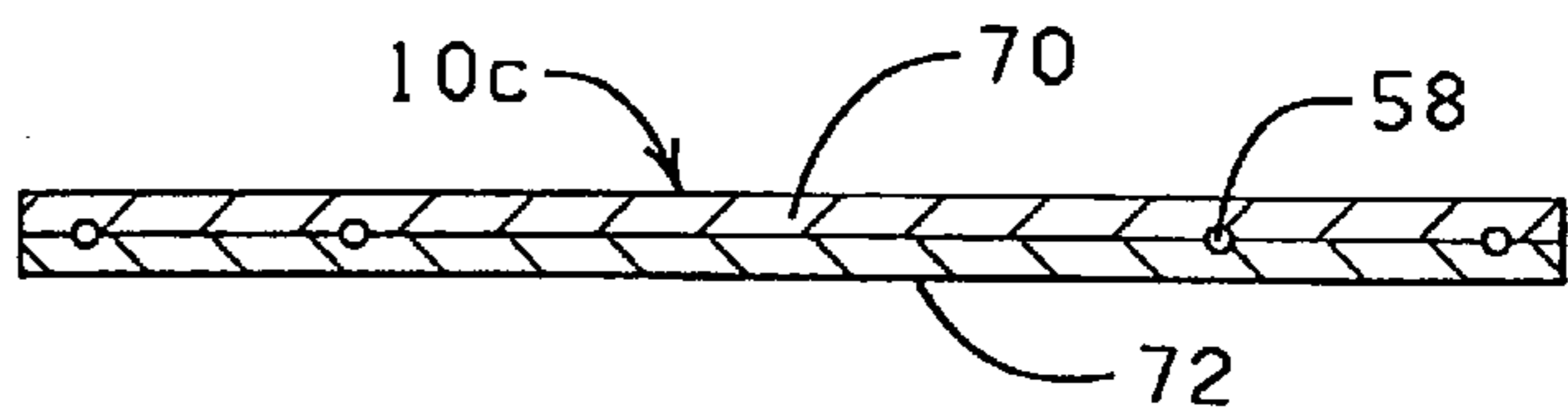

FIG. 9

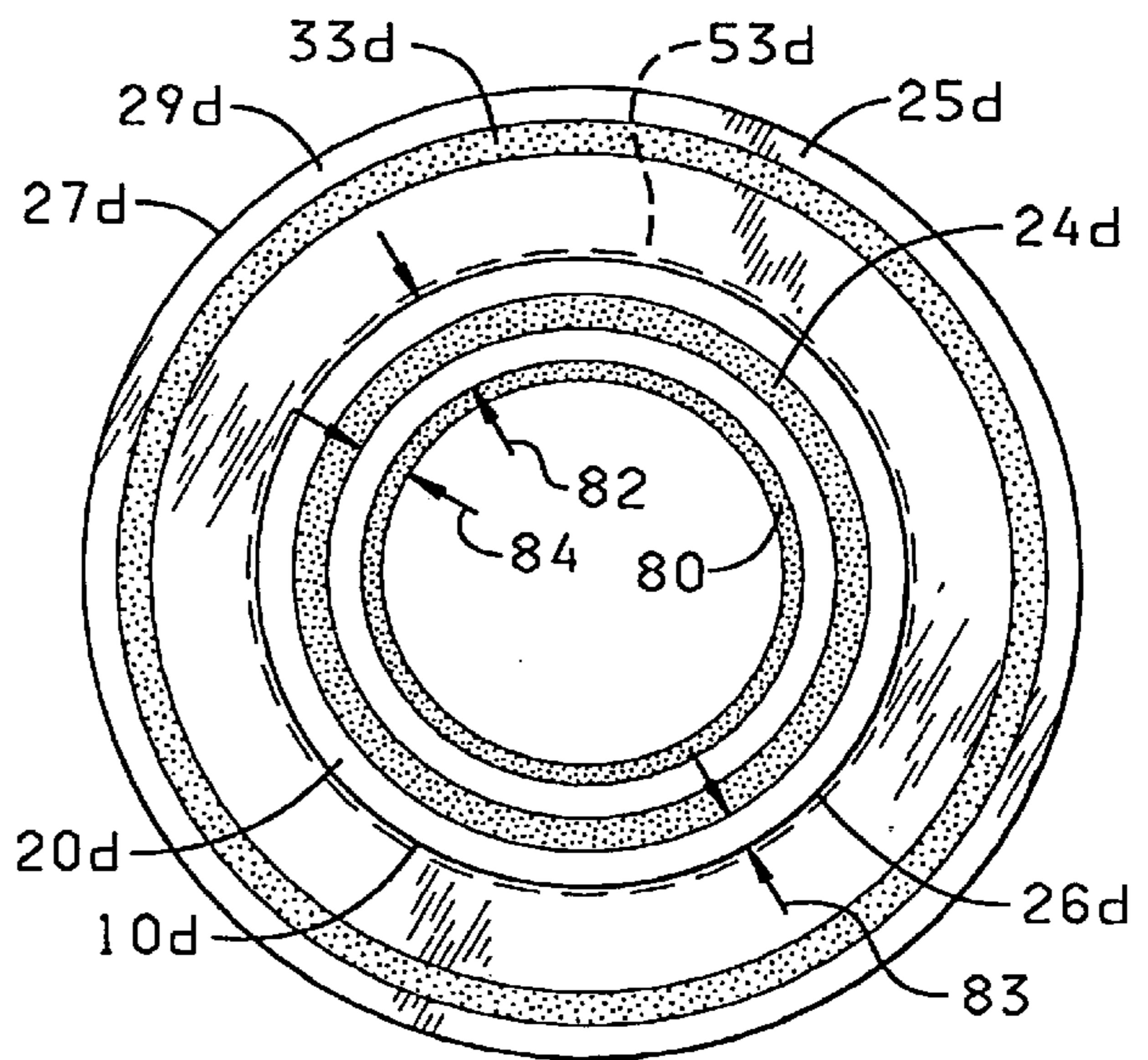
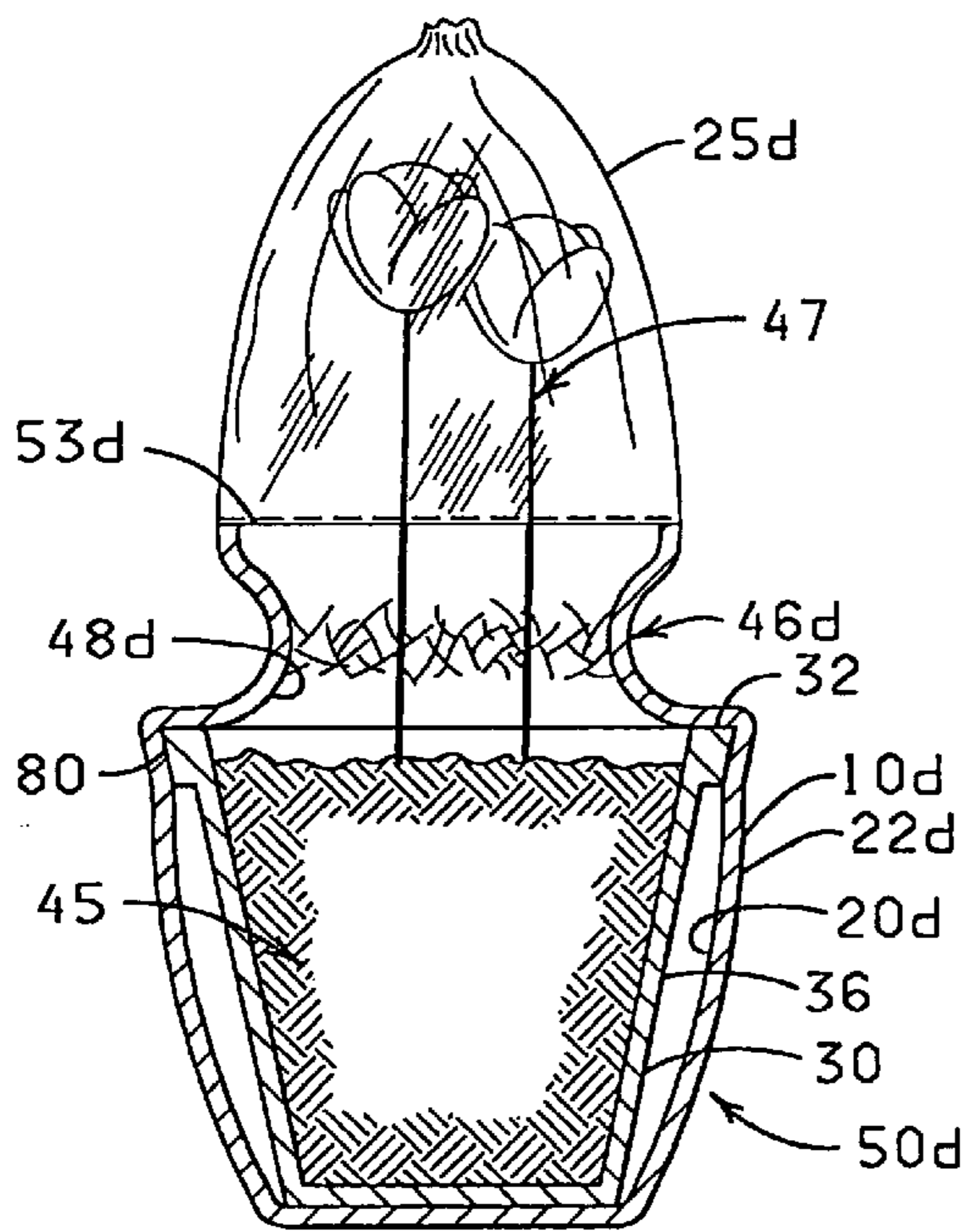

FIG. 10

FIG. 11

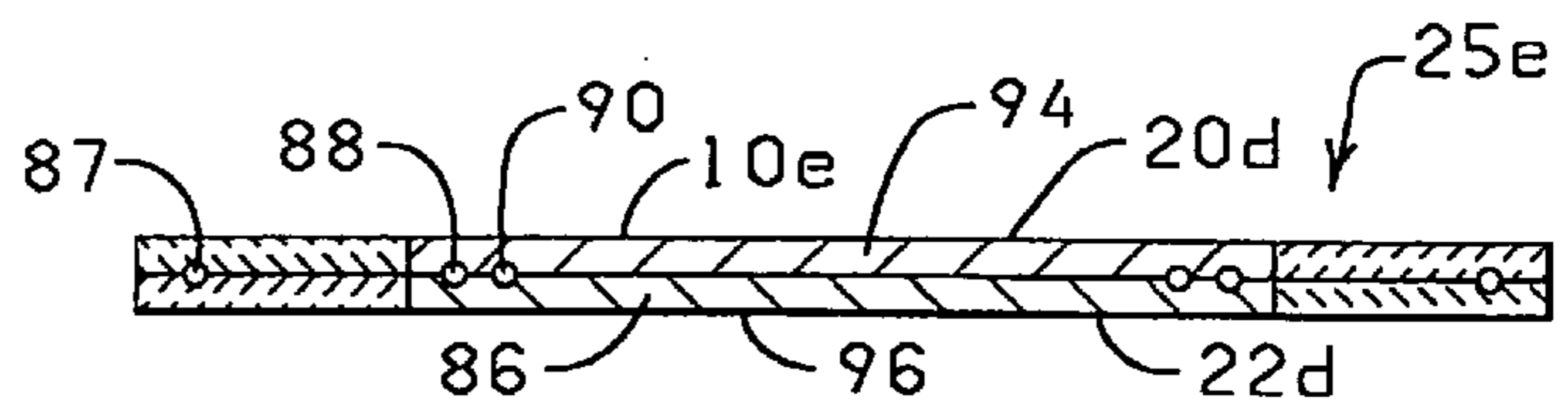

FIG. 12

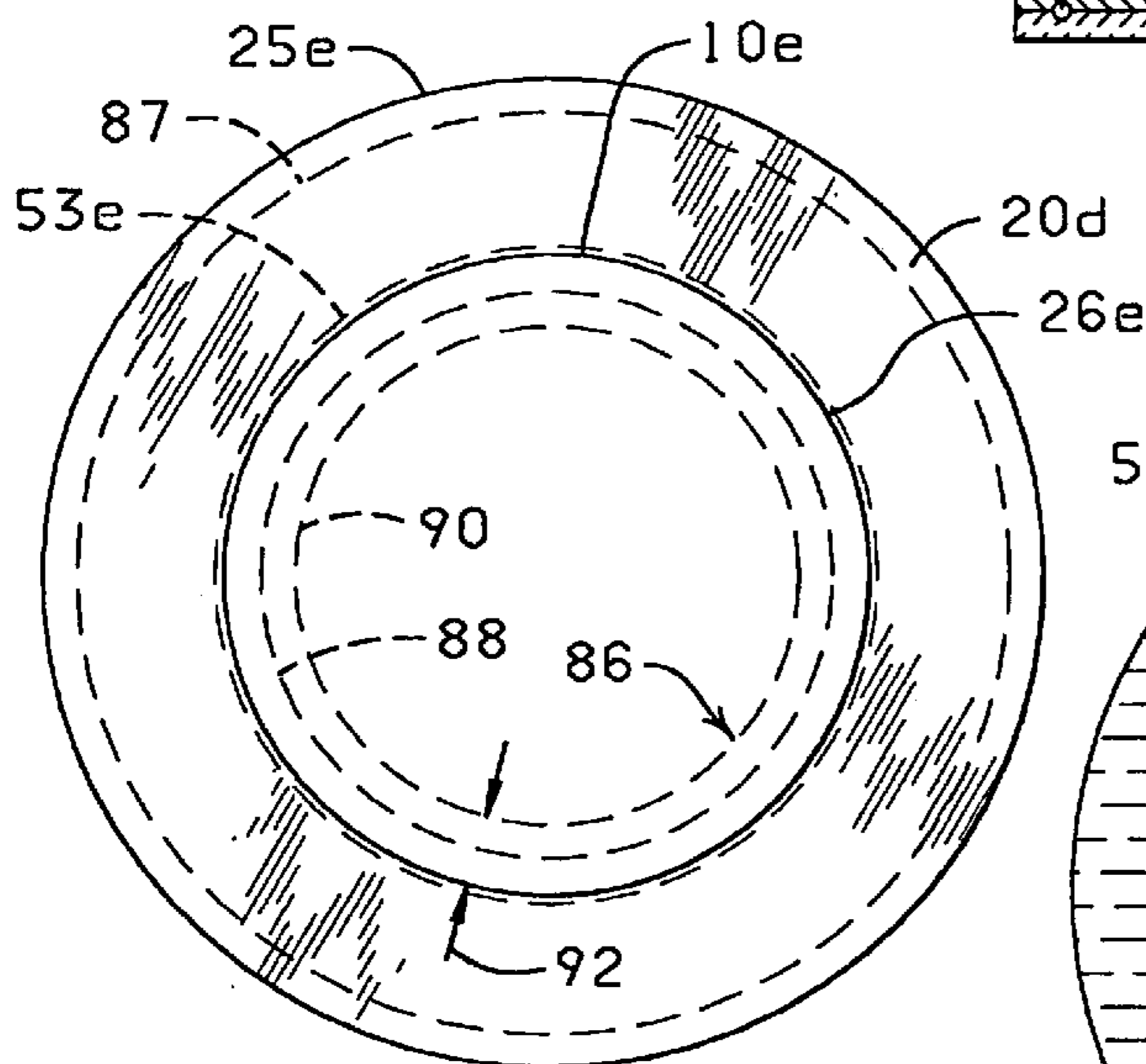

FIG. 13

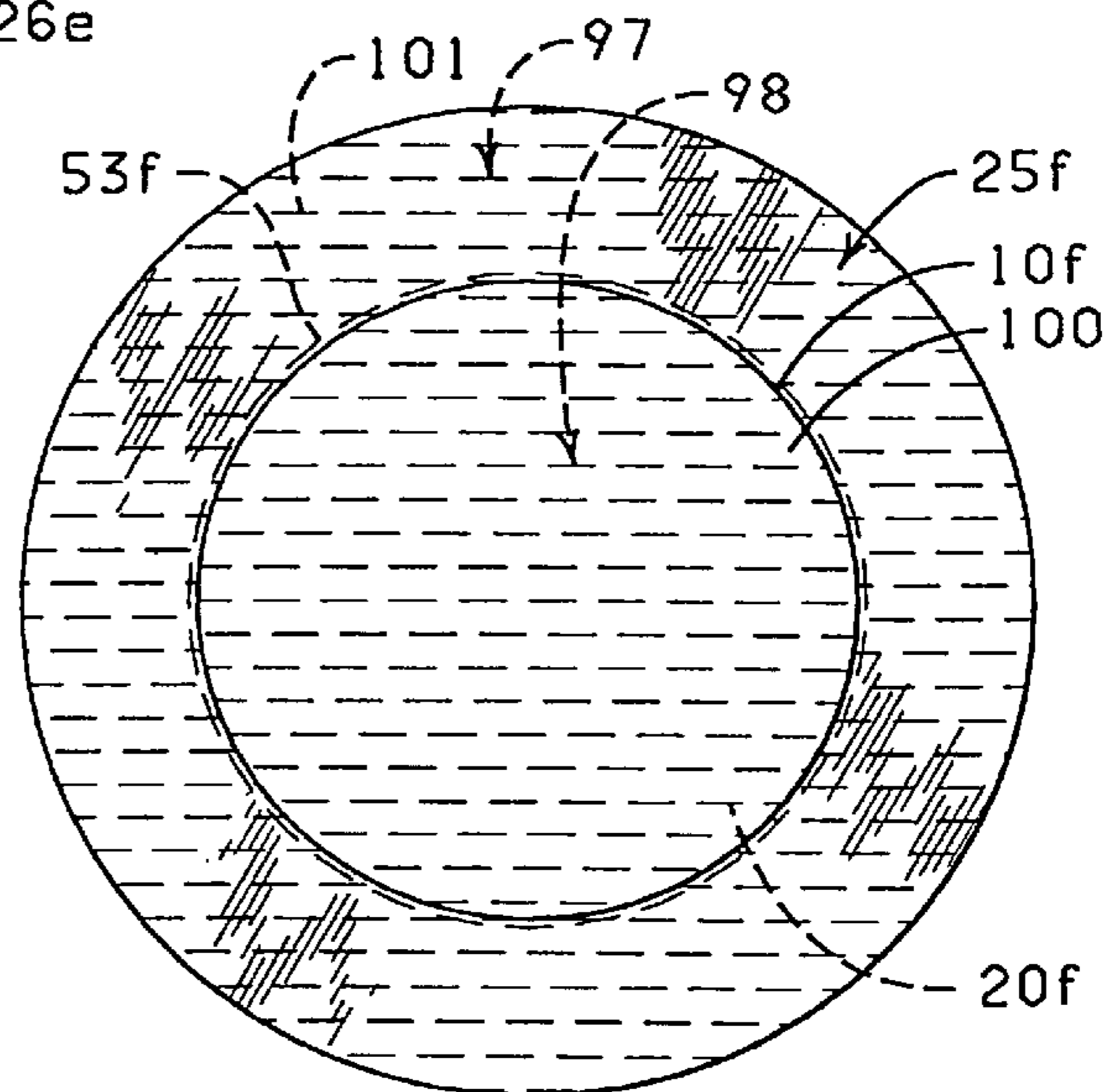

FIG. 14

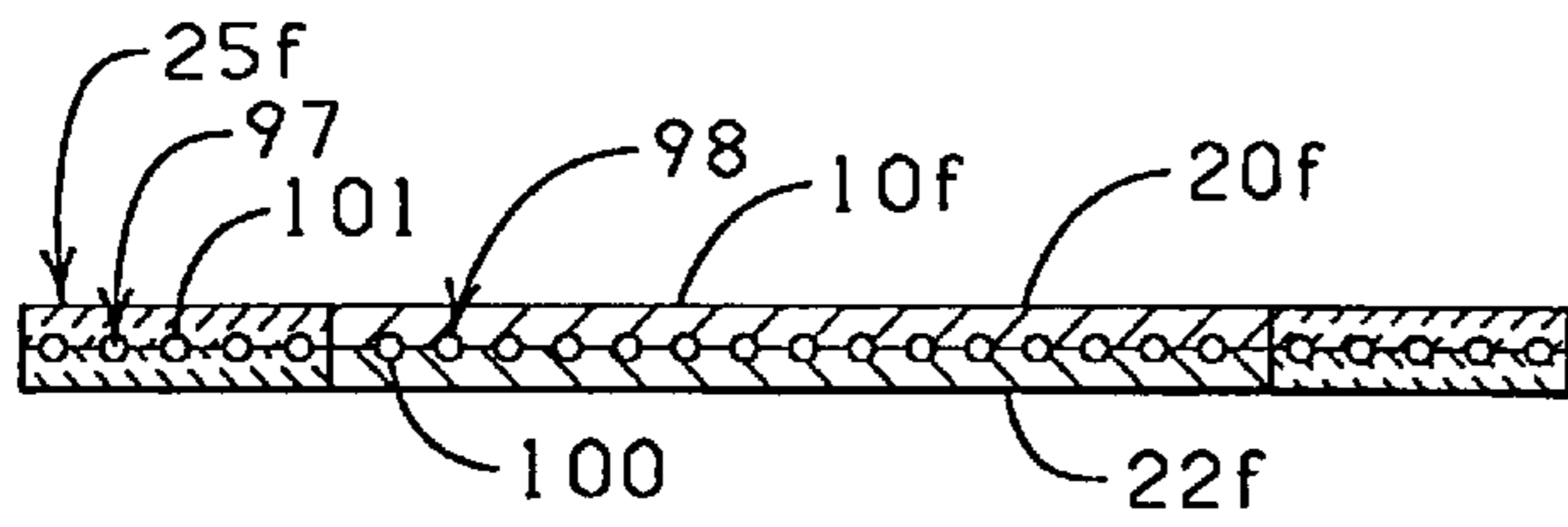

FIG. 15

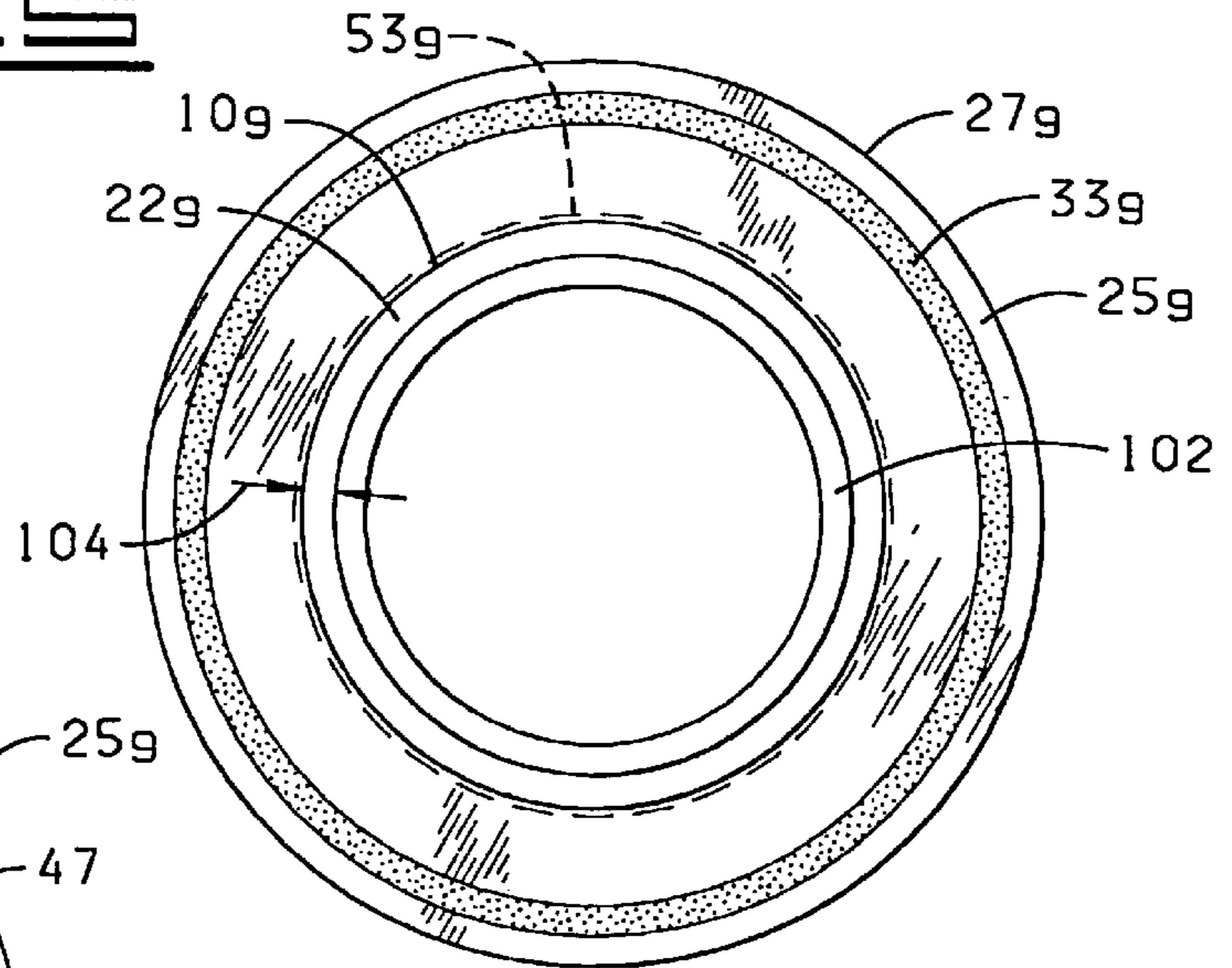

FIG. 16

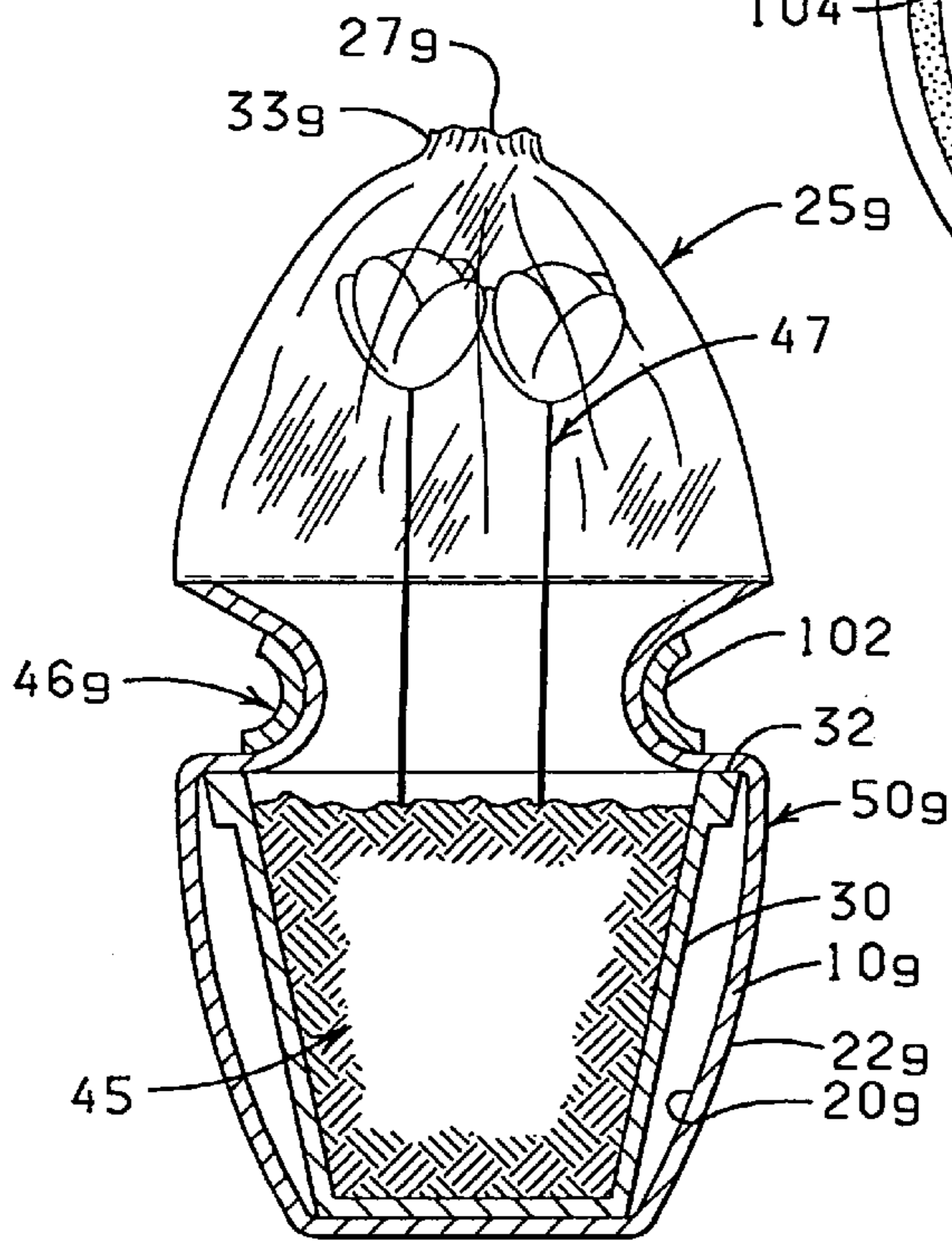

FIG. 17

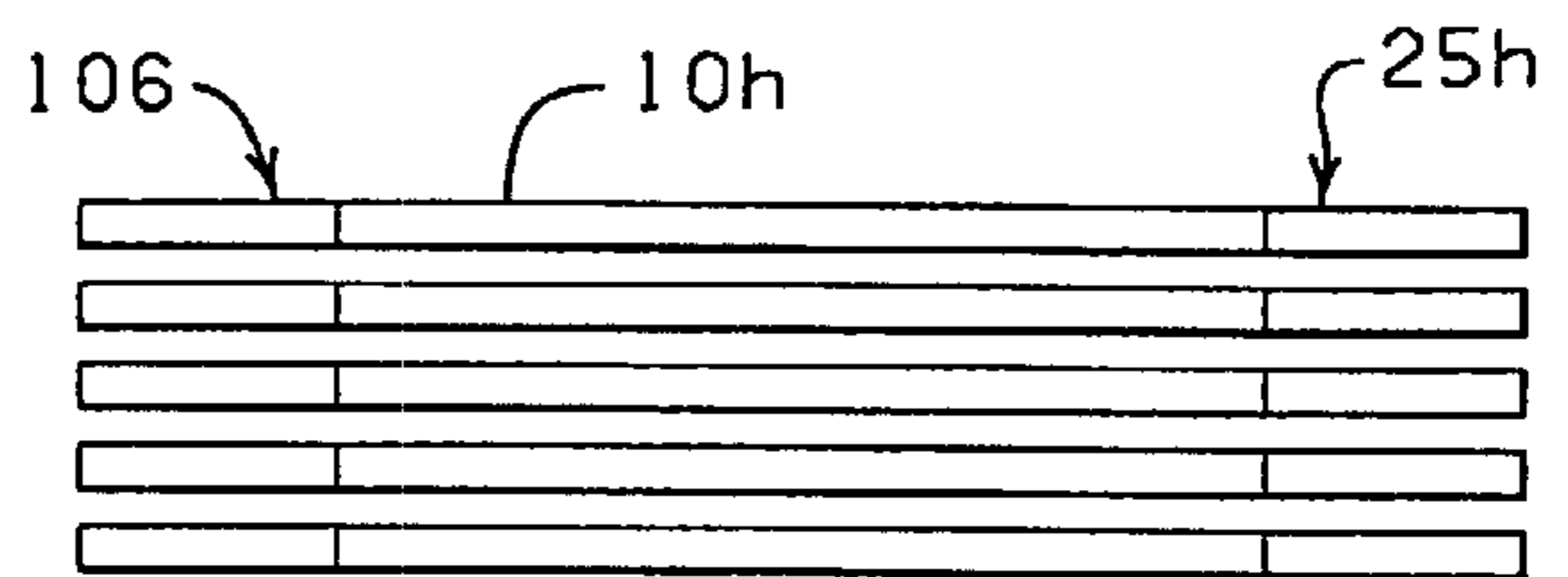

FIG. 18

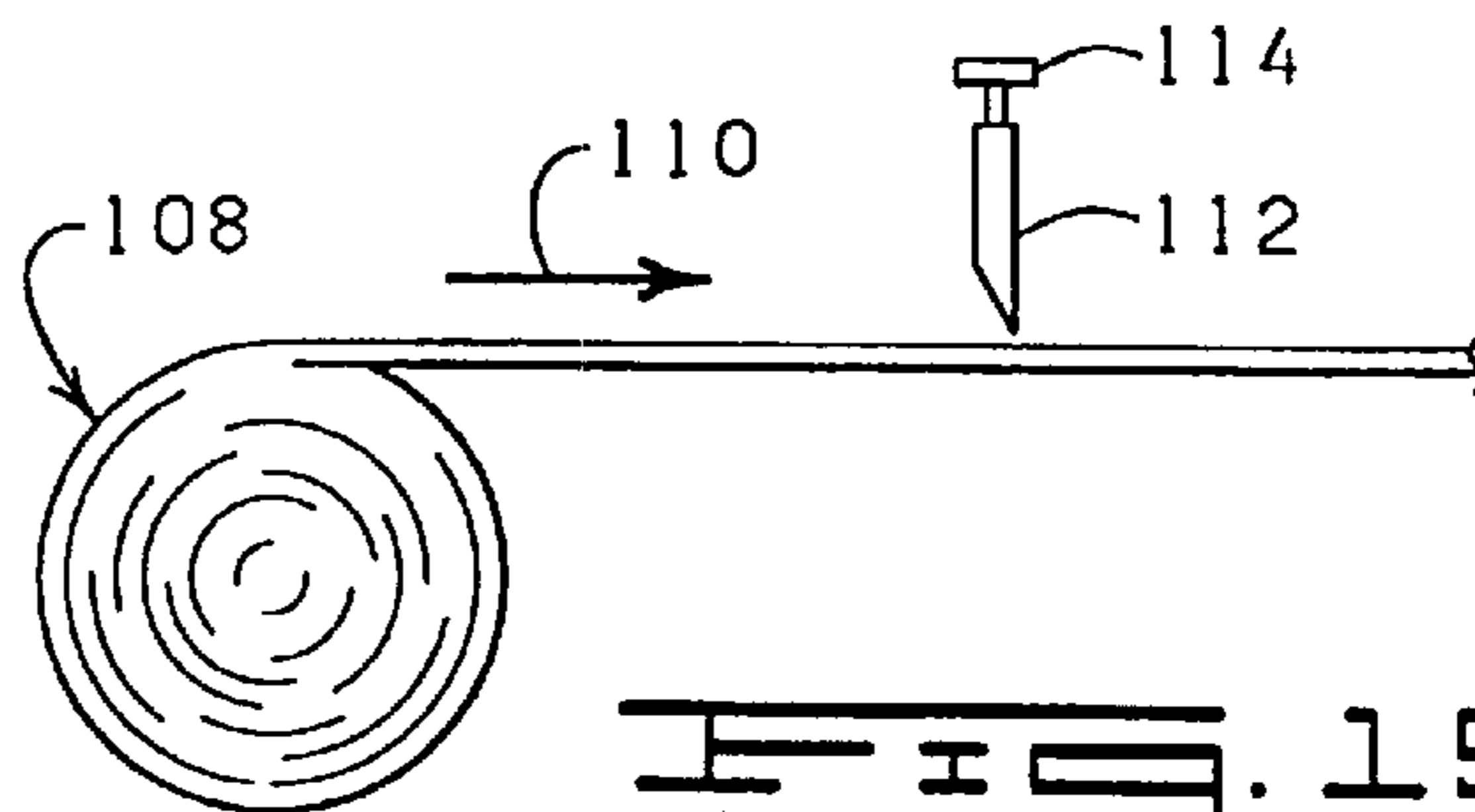

FIG. 19

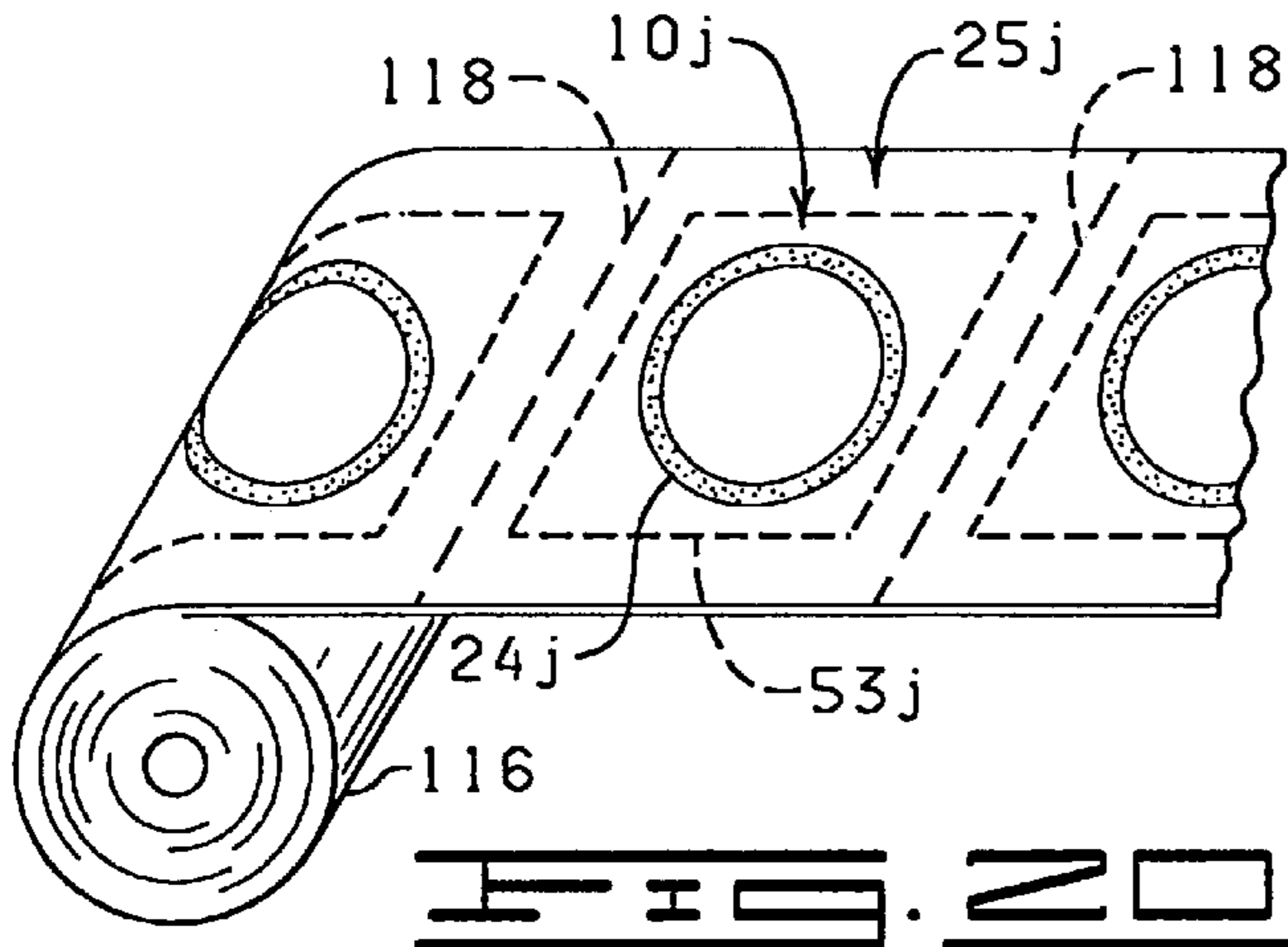

FIG. 20

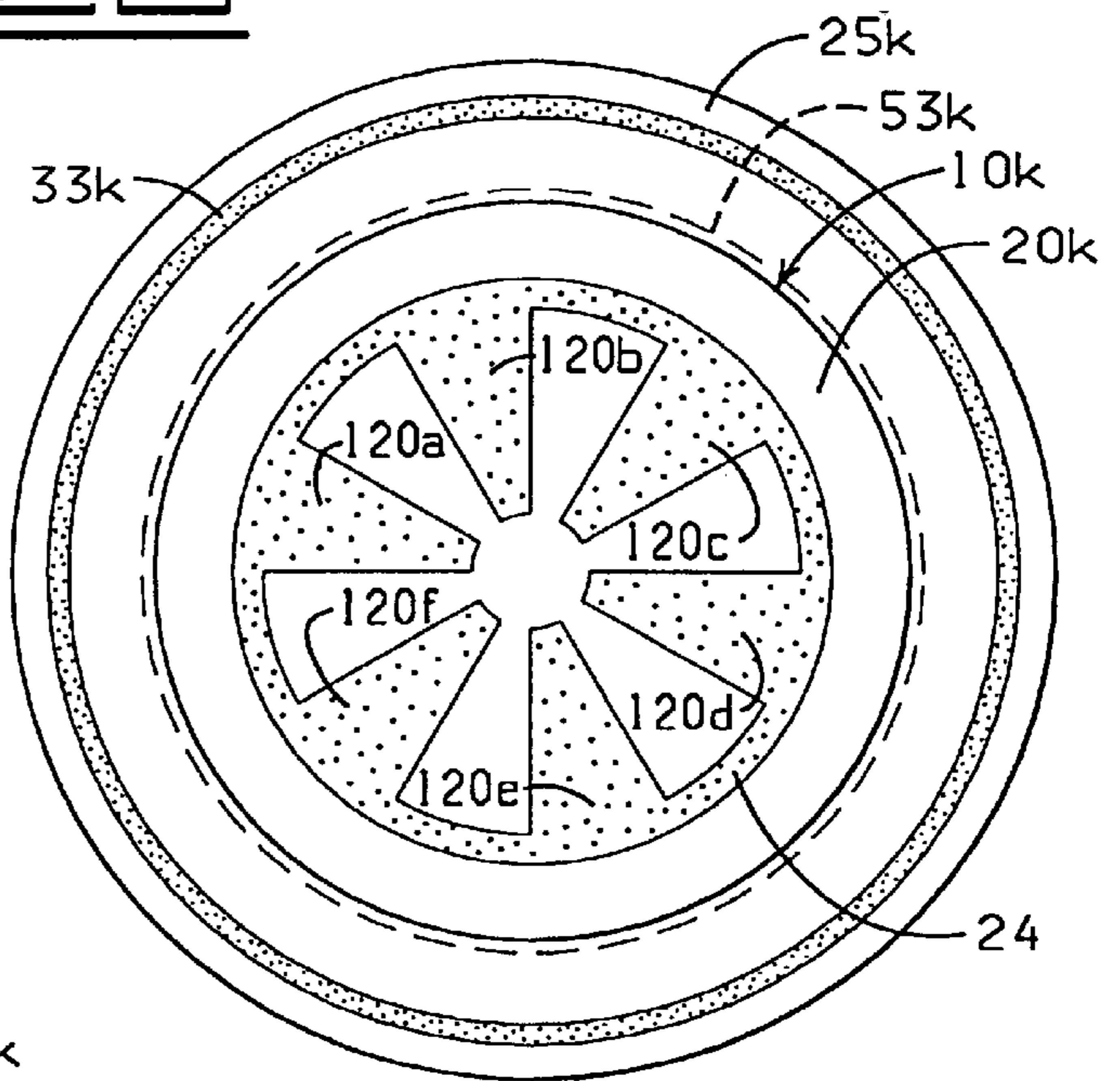

FIG. 21

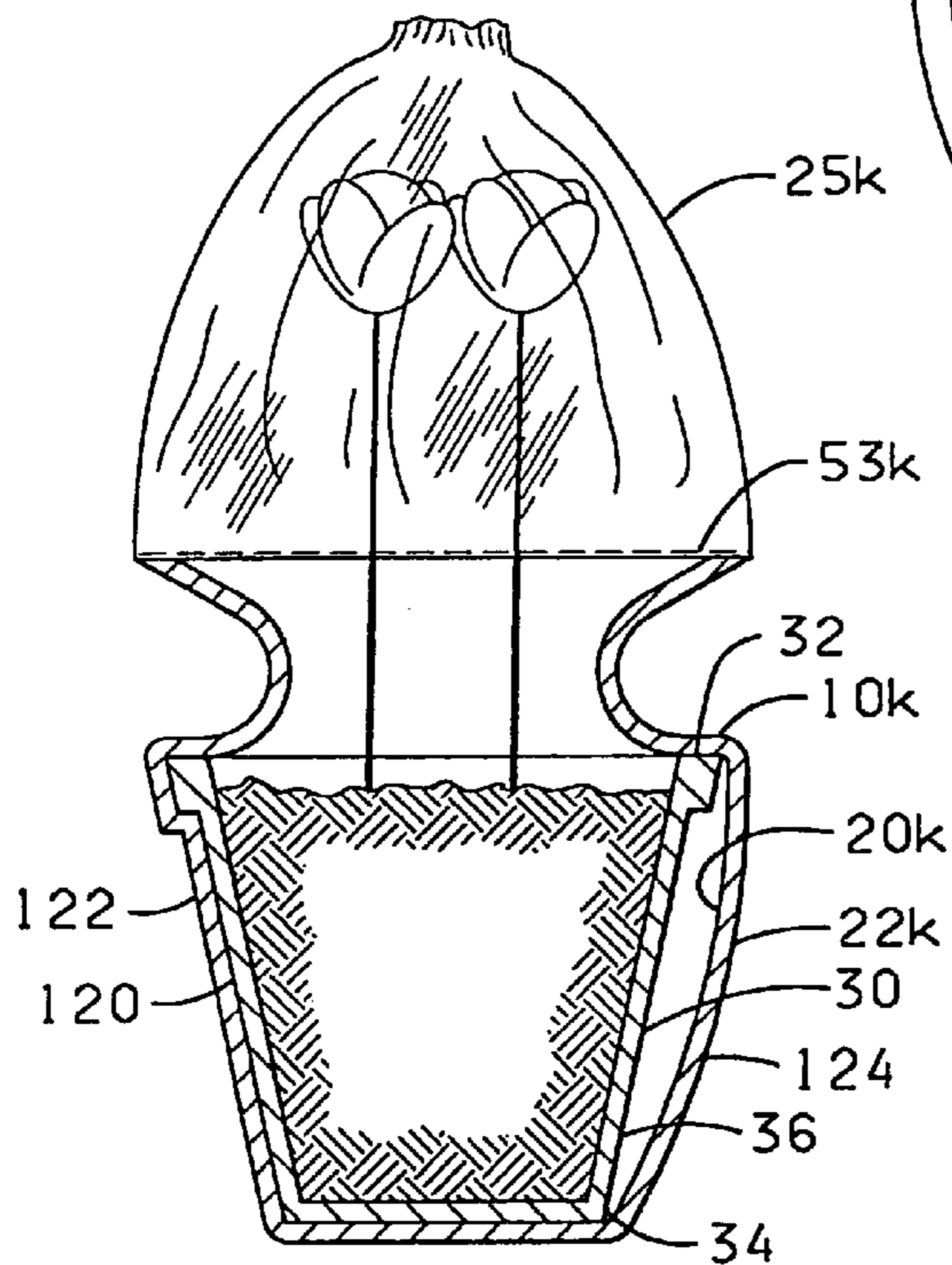
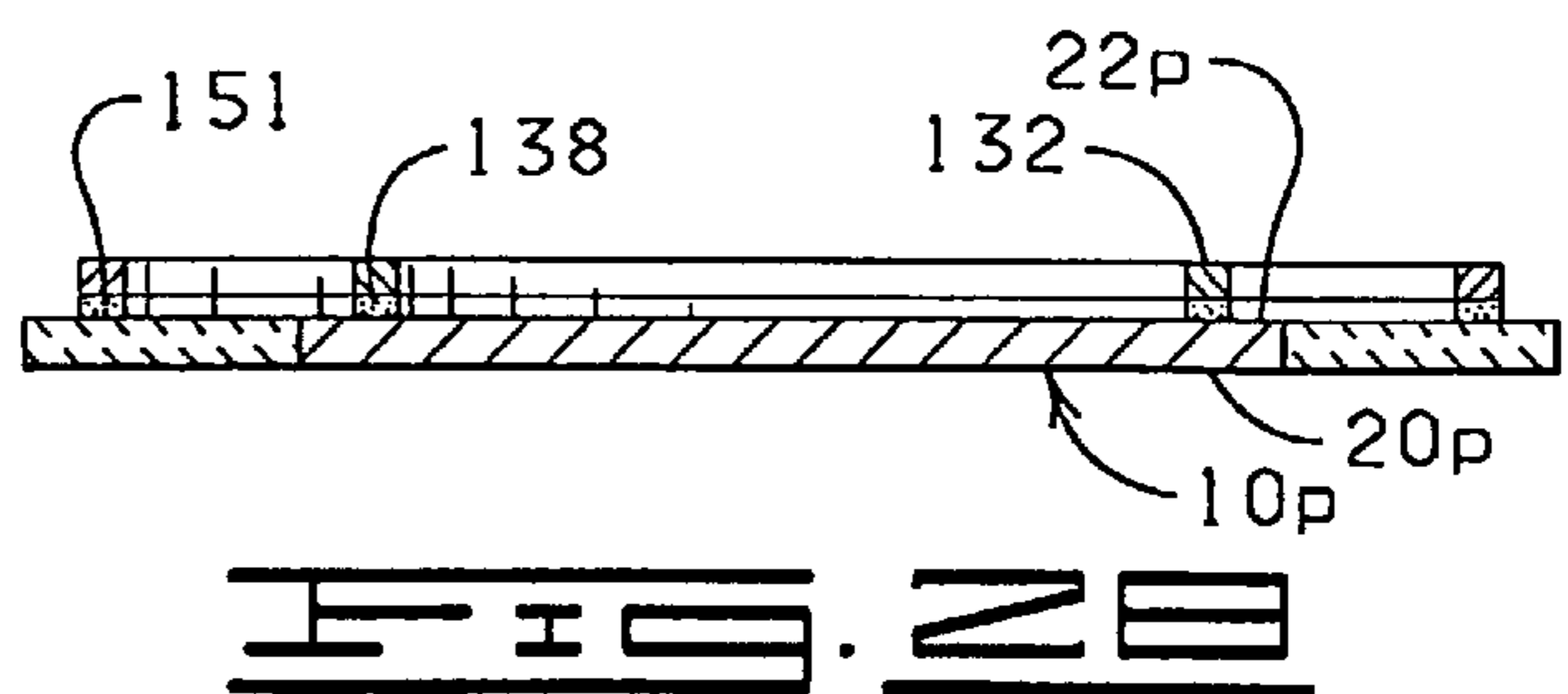
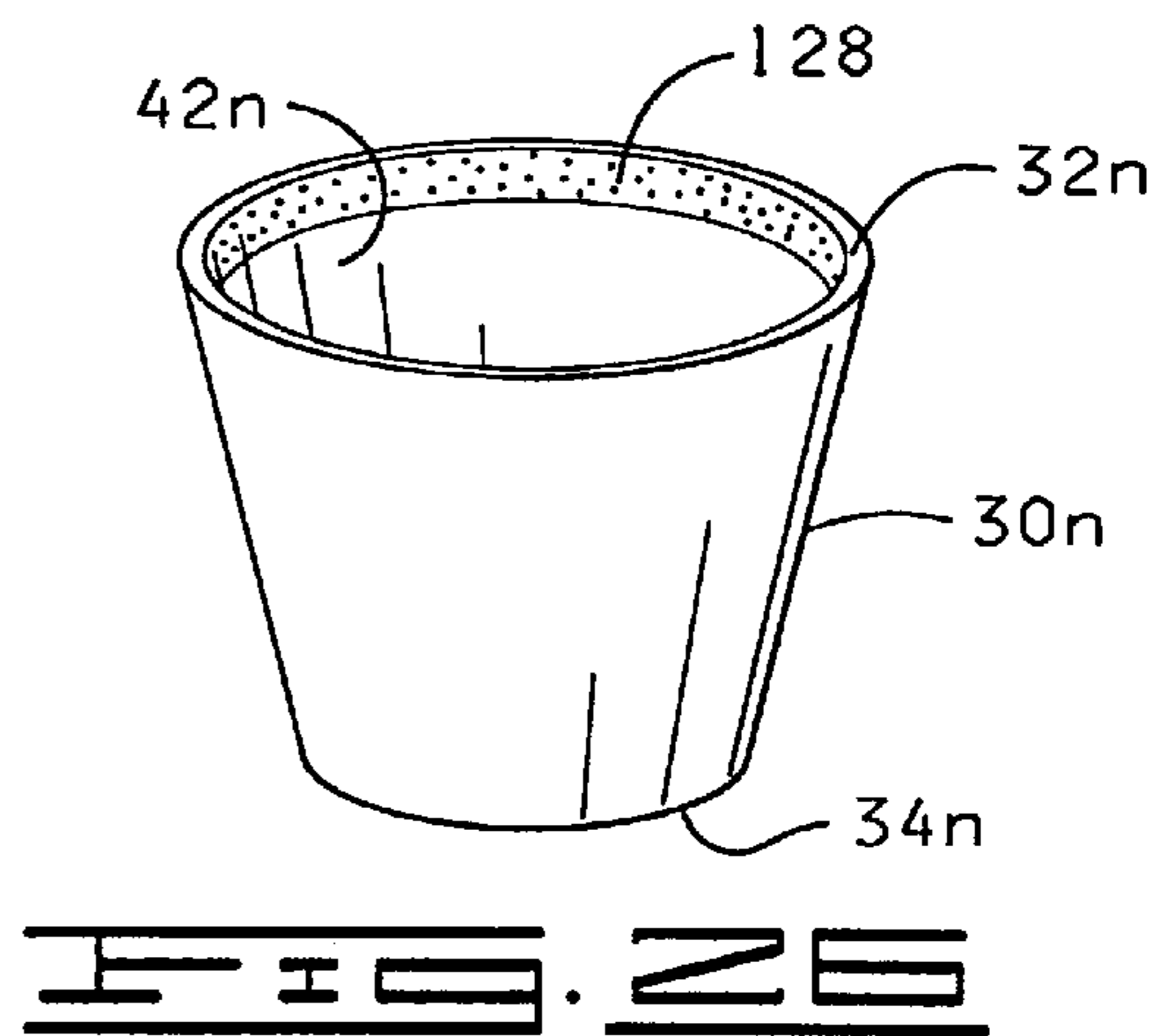
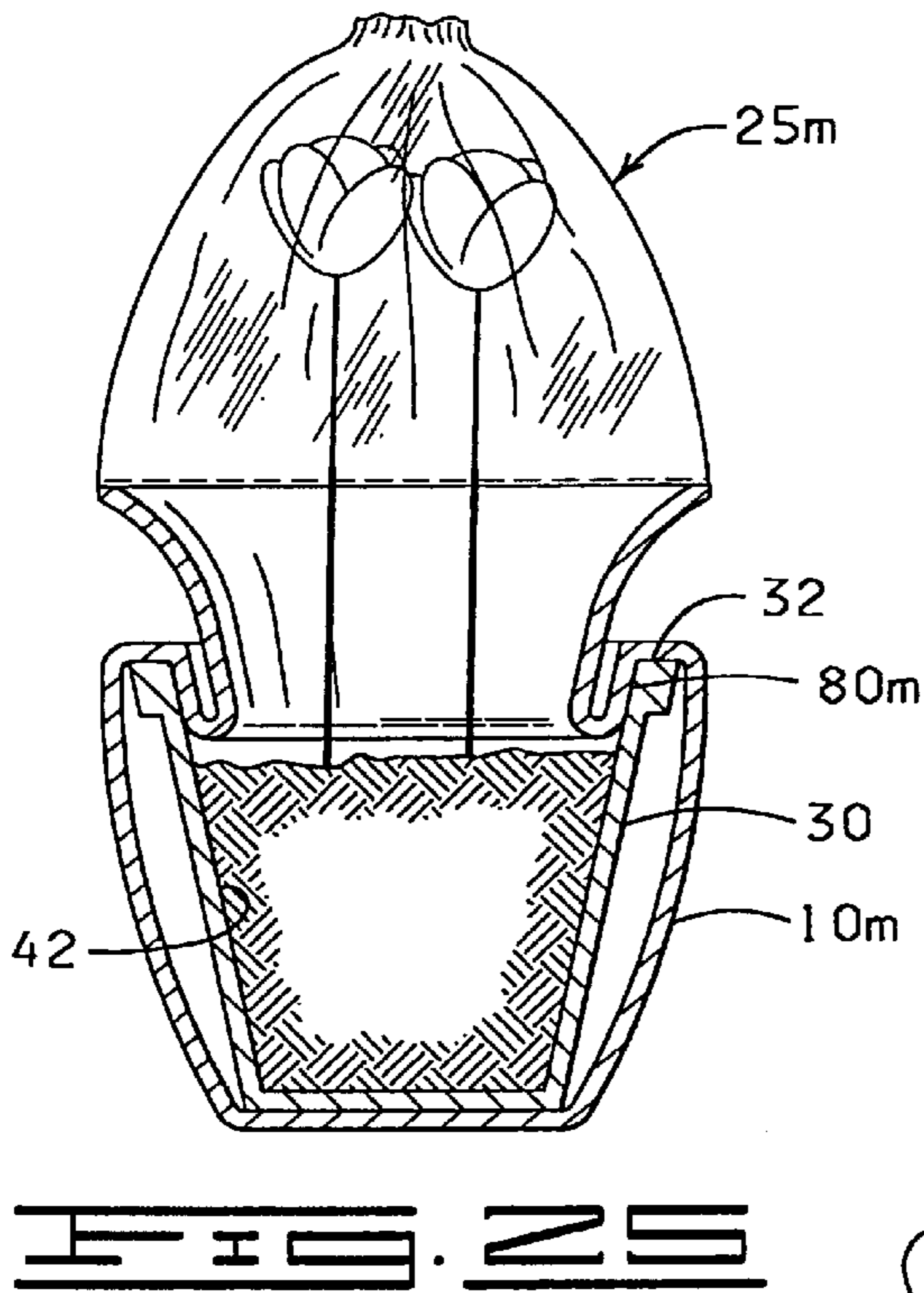
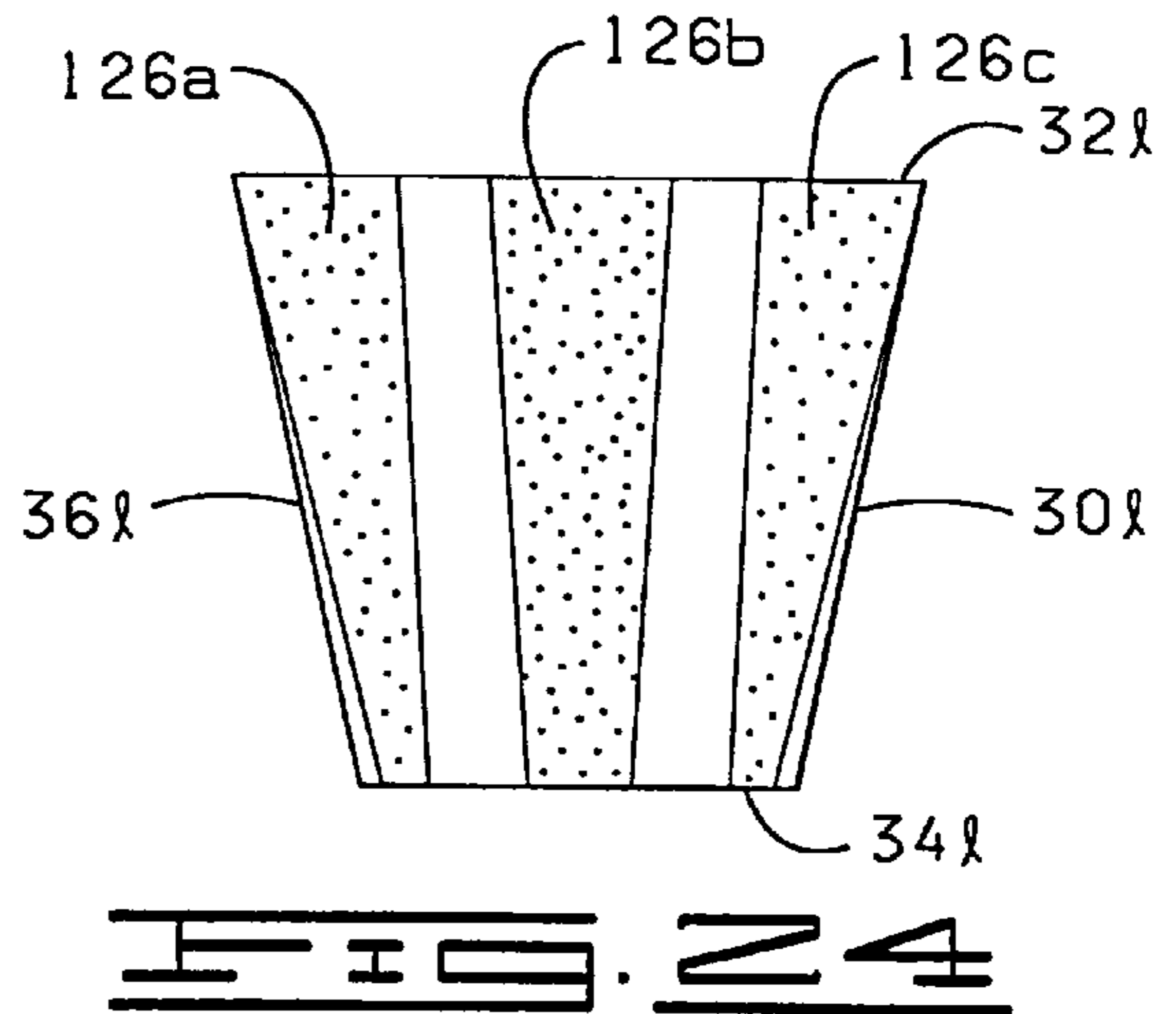
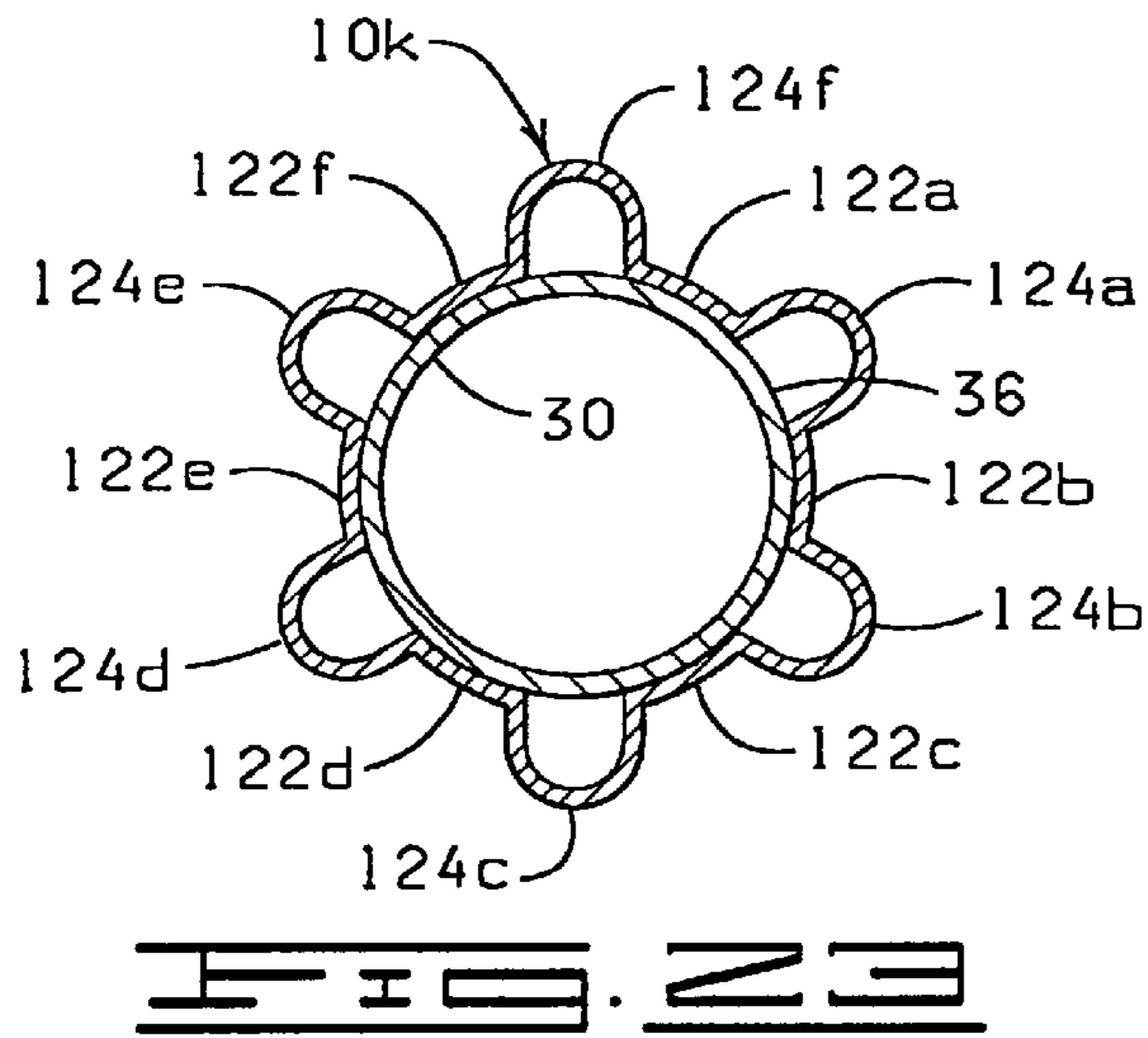

FIG. 22



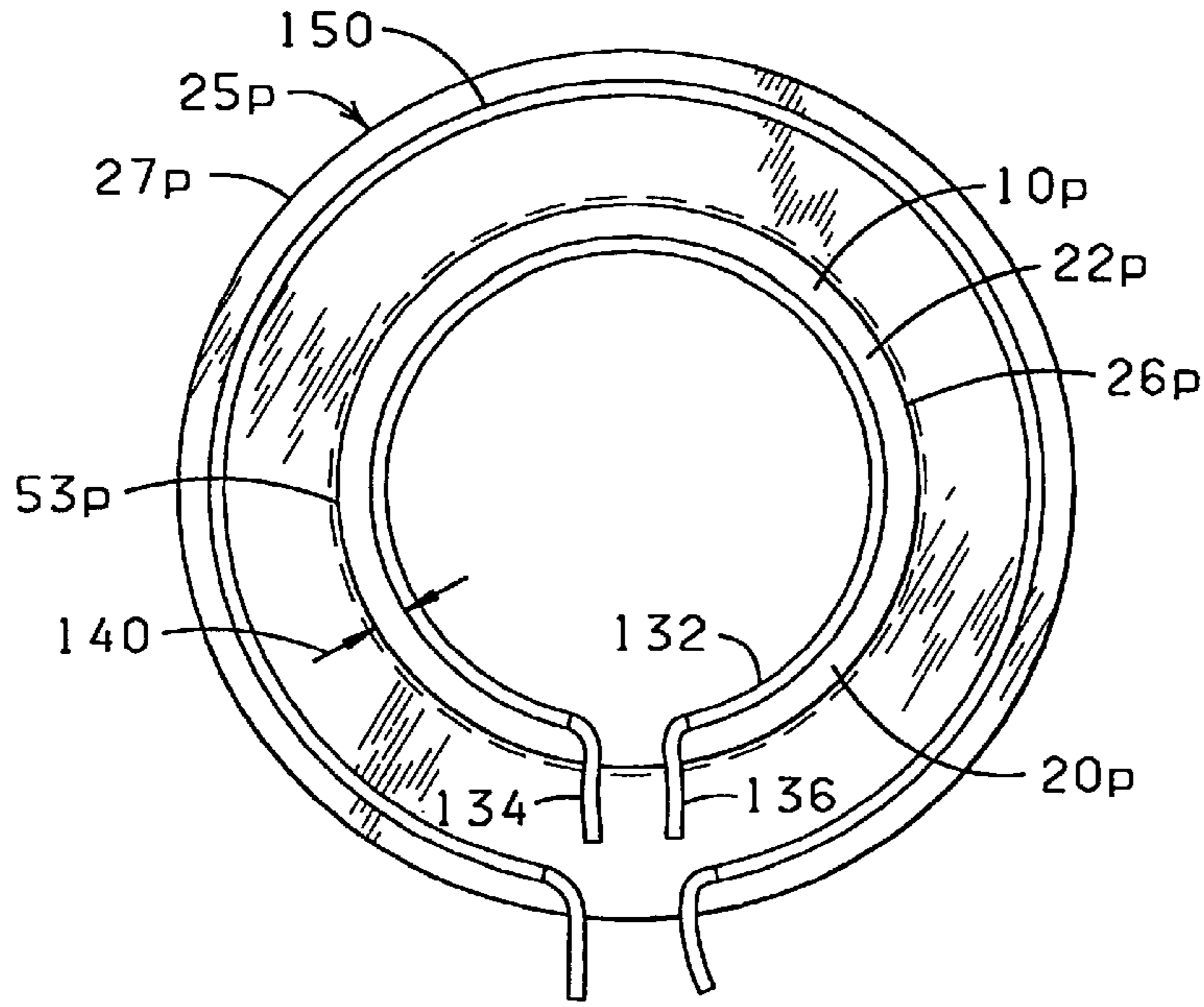

FIG. 27

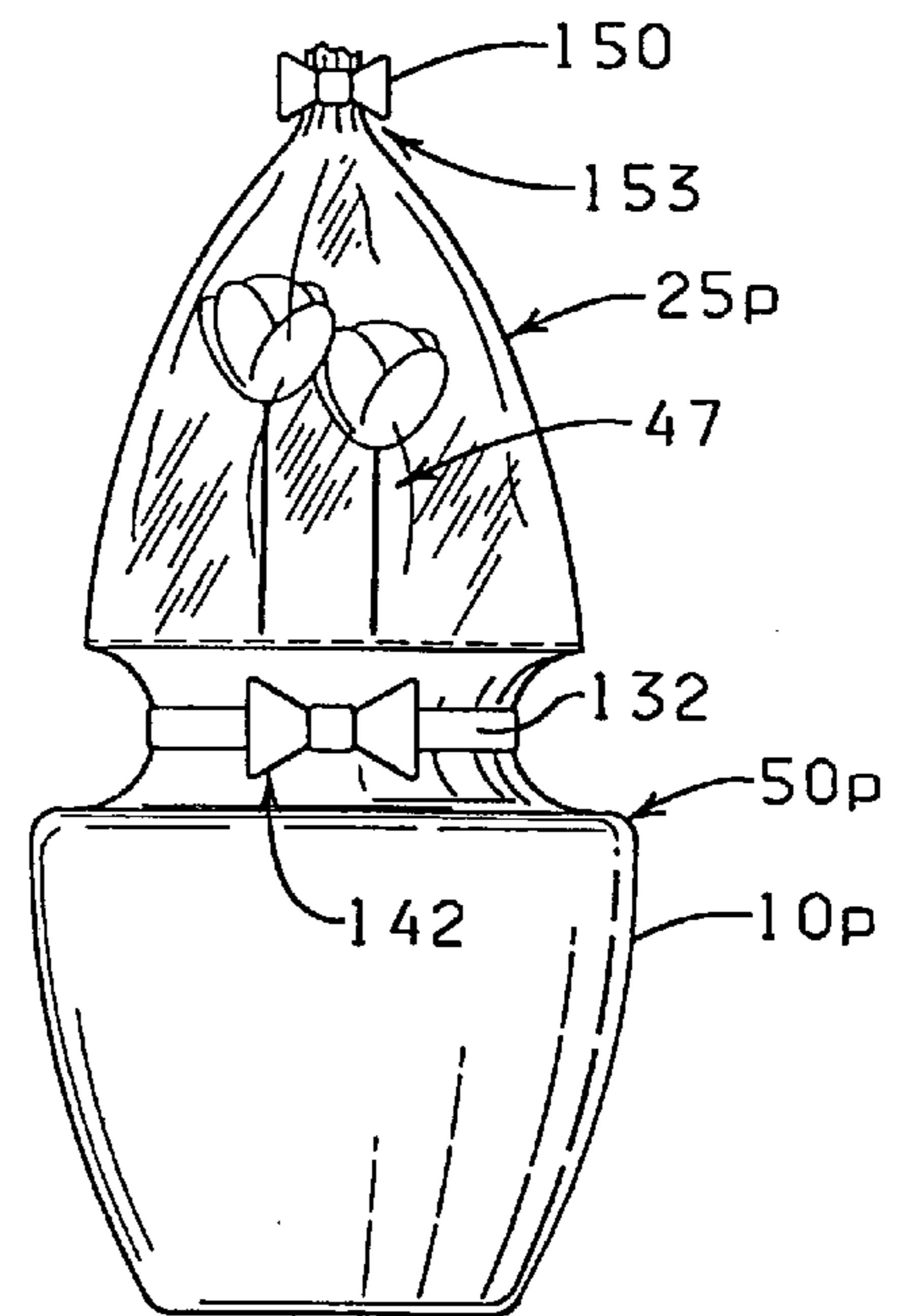

FIG. 28

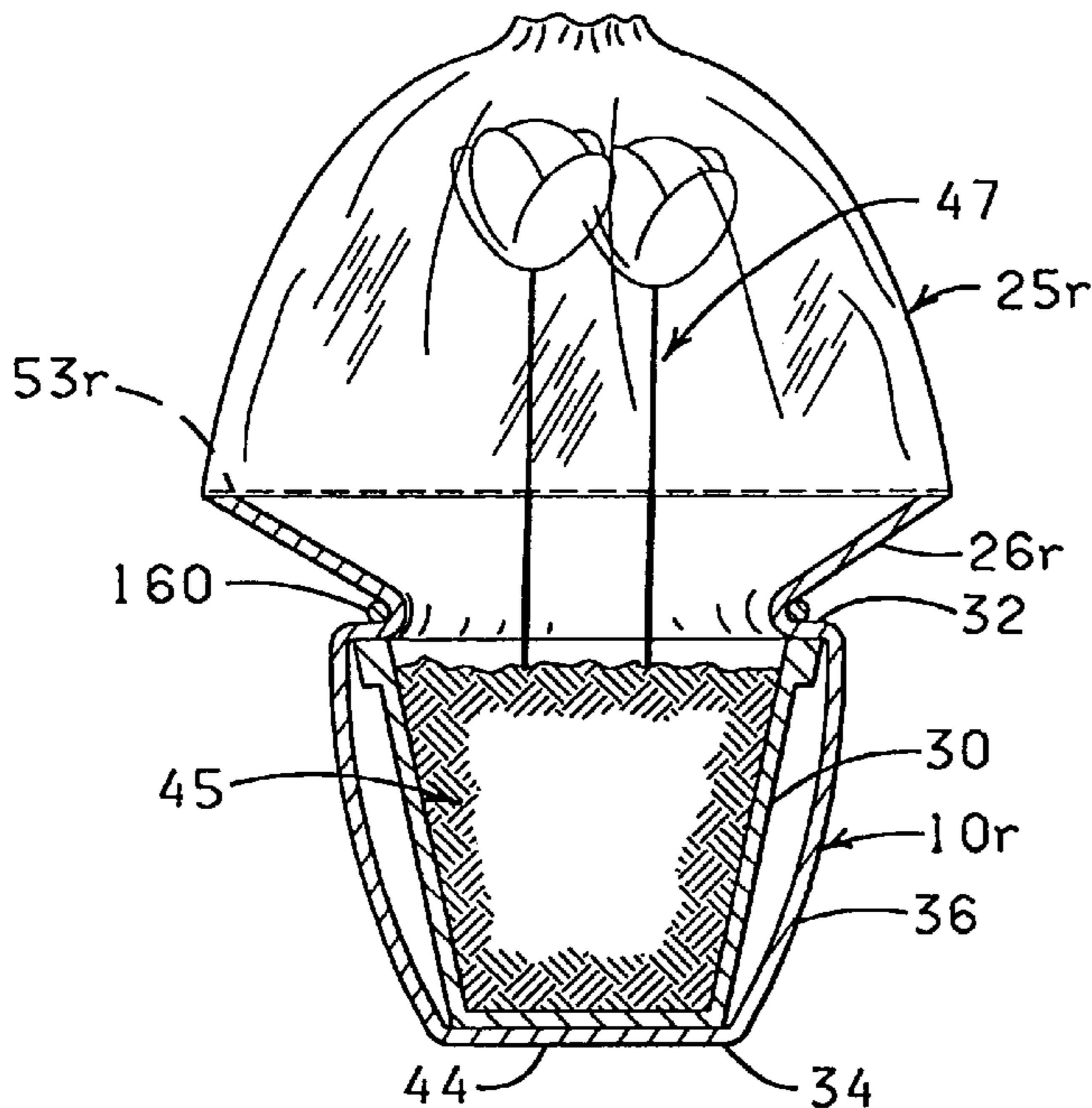

FIG. 29

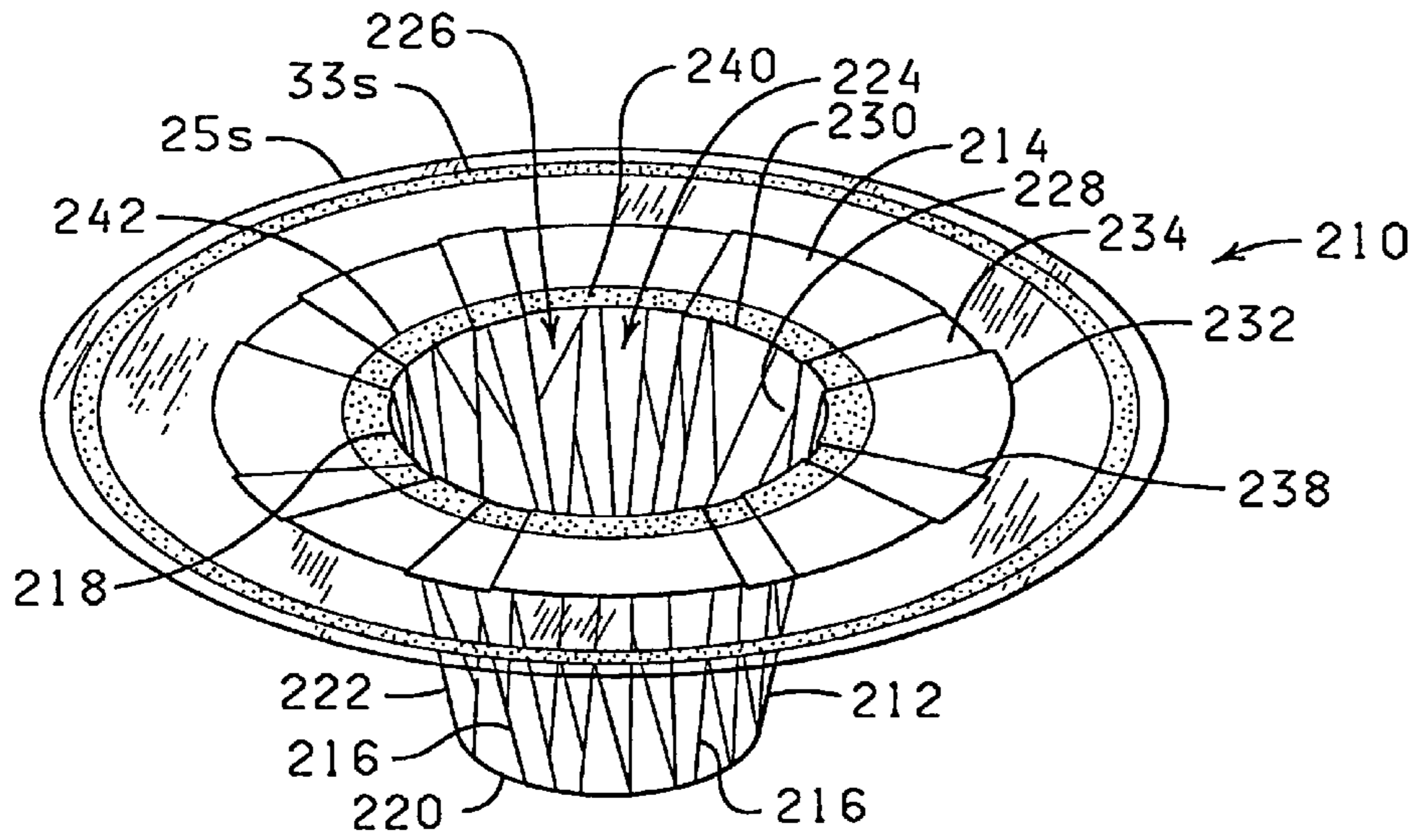

FIG. 31

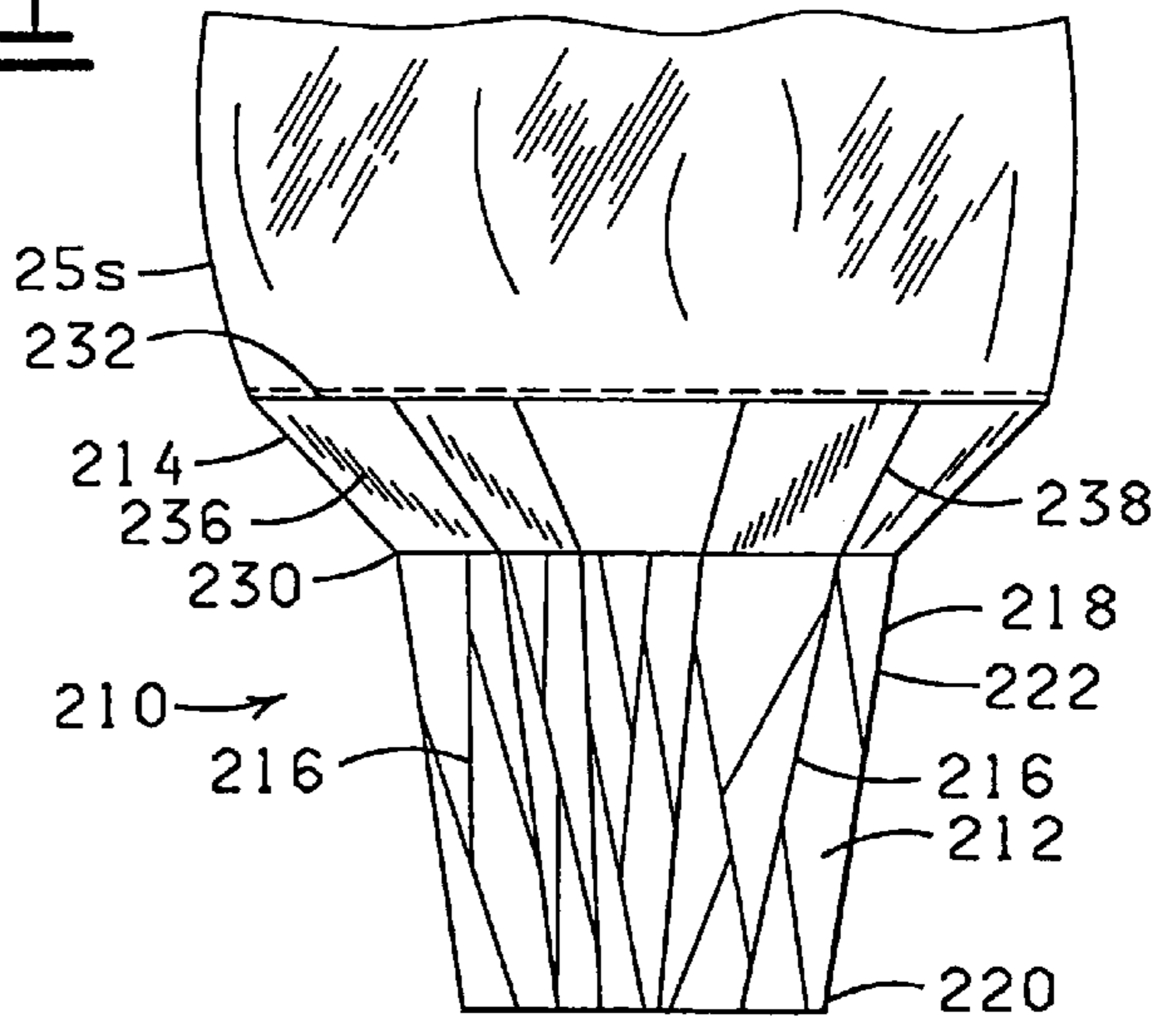

FIG. 32

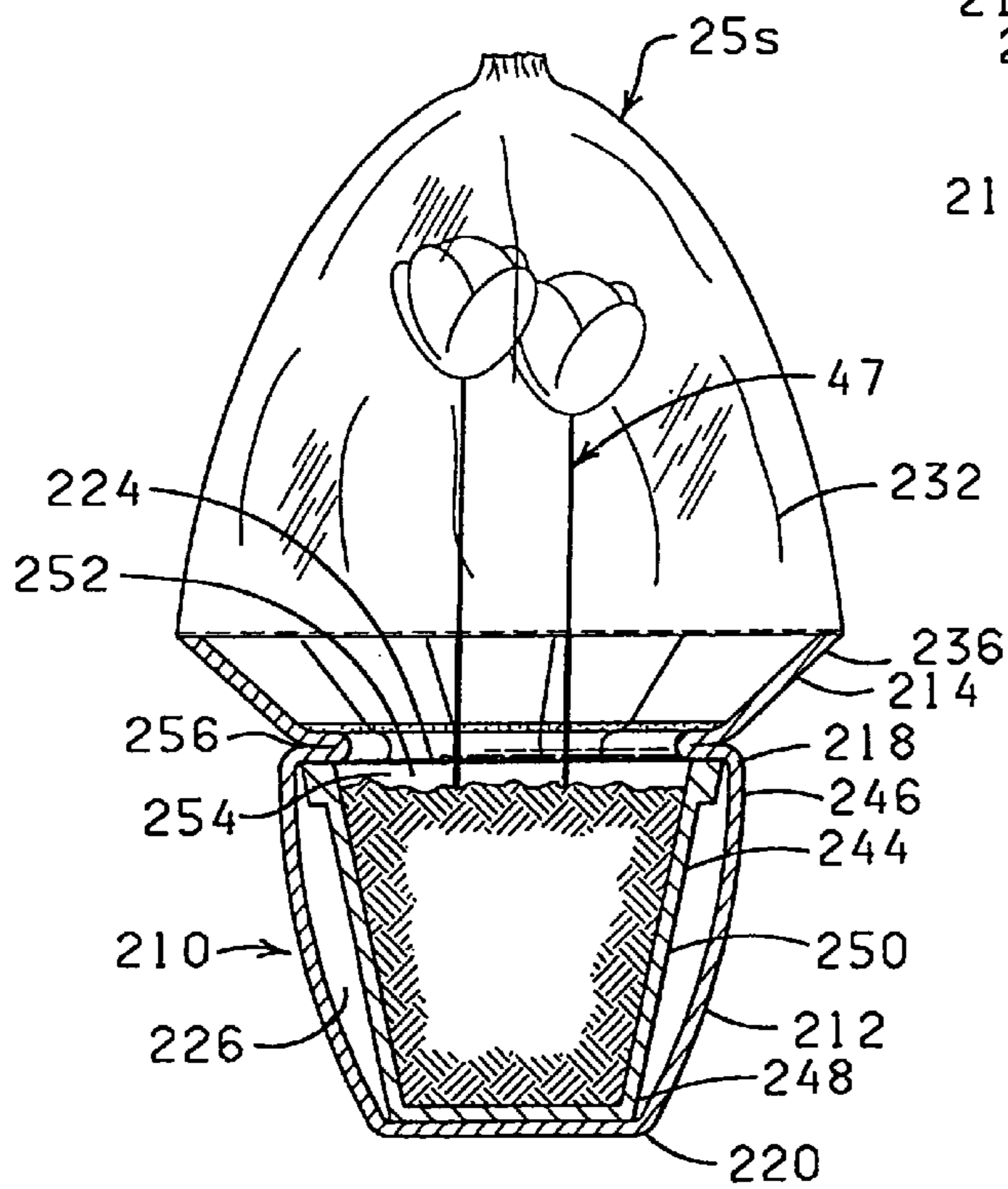

FIG. 33

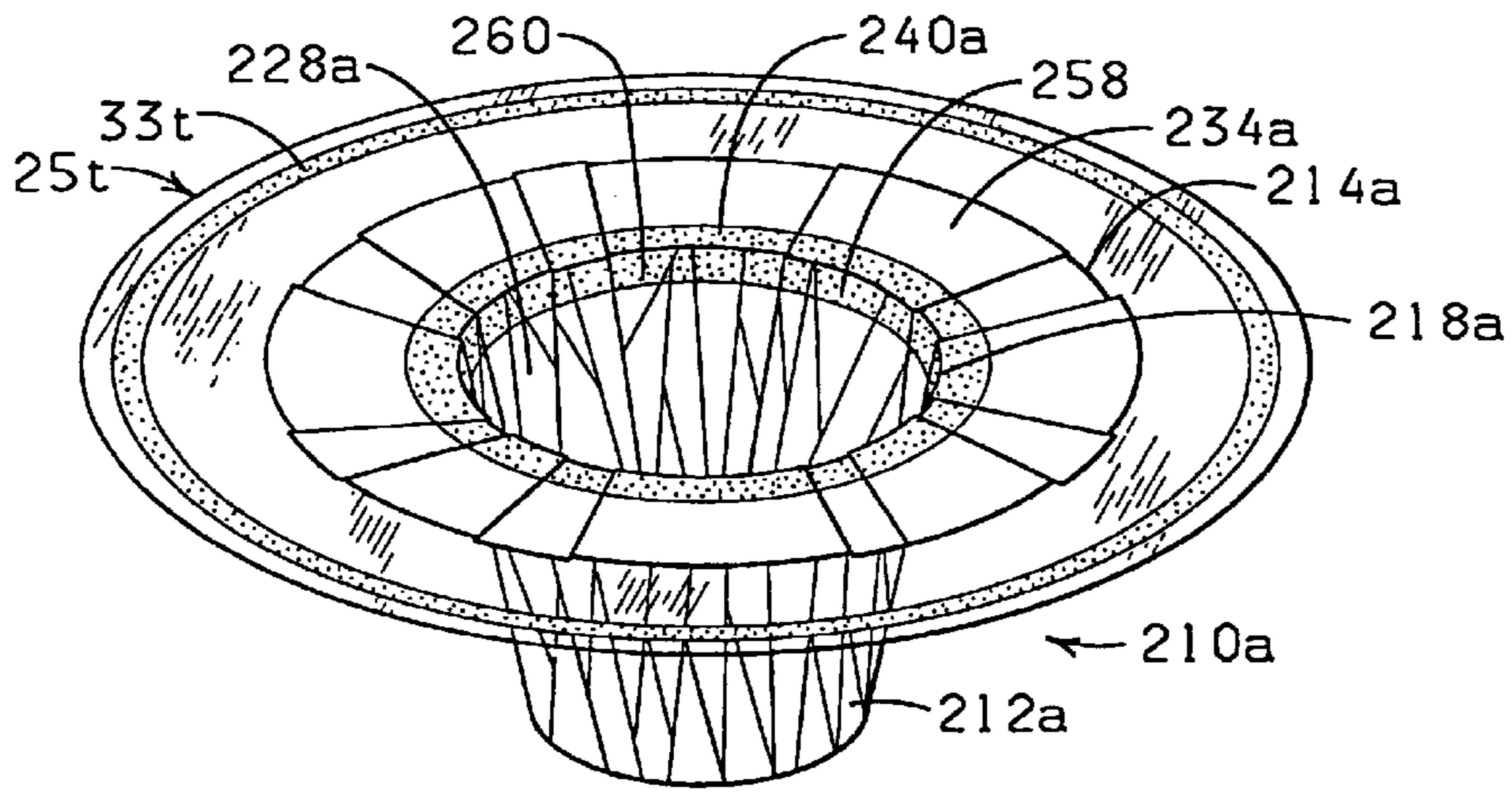

FIG. 34

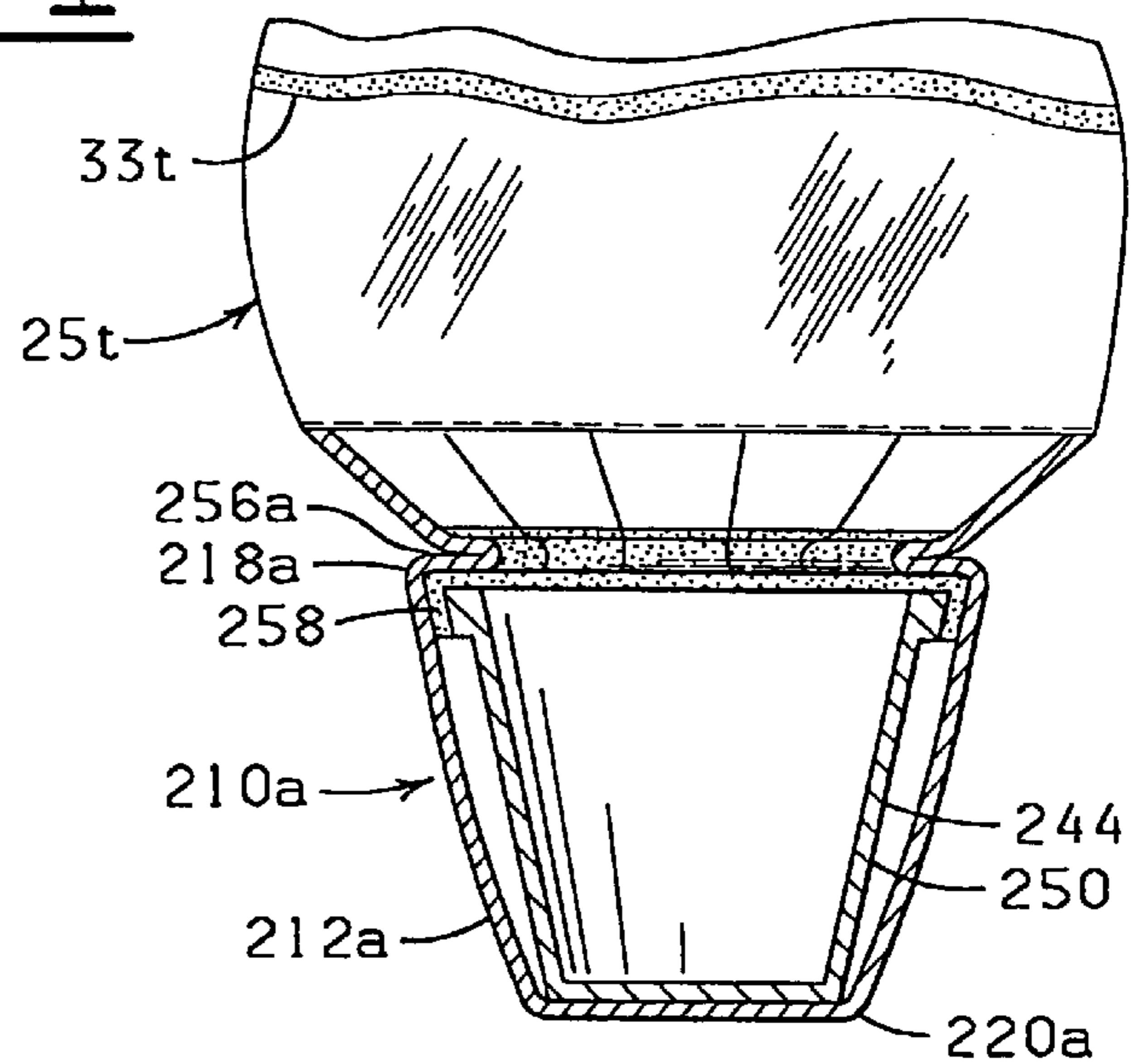

FIG. 35

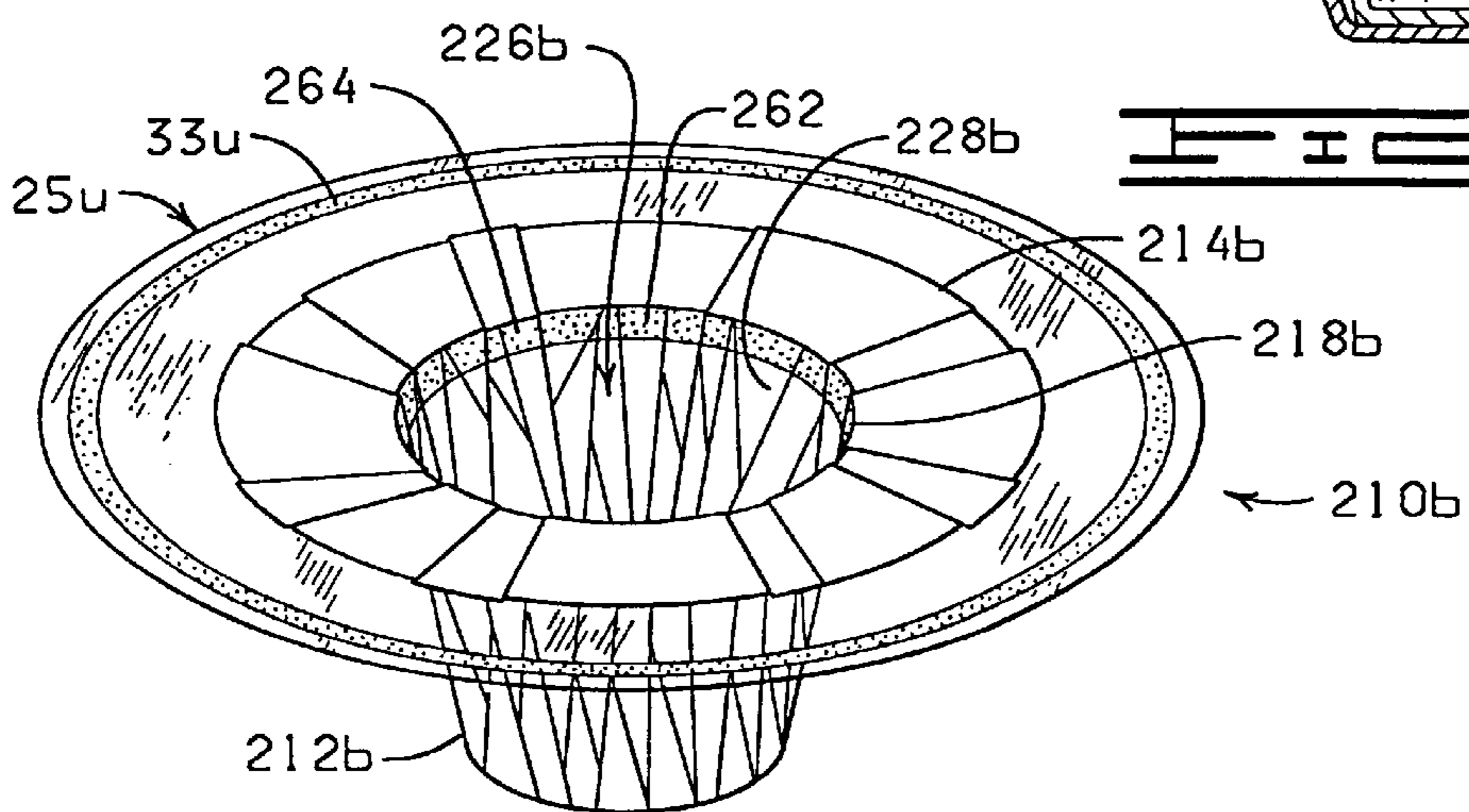
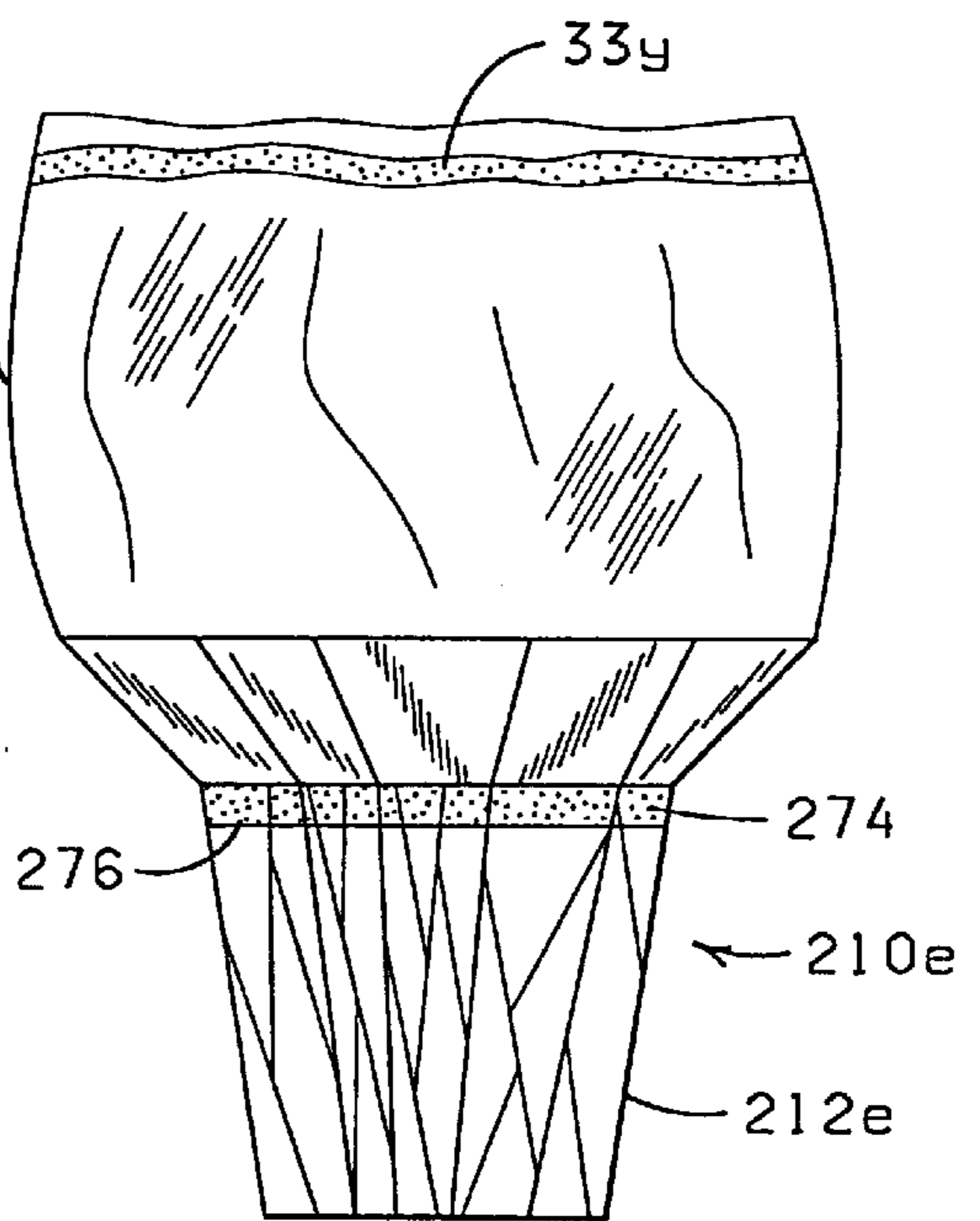
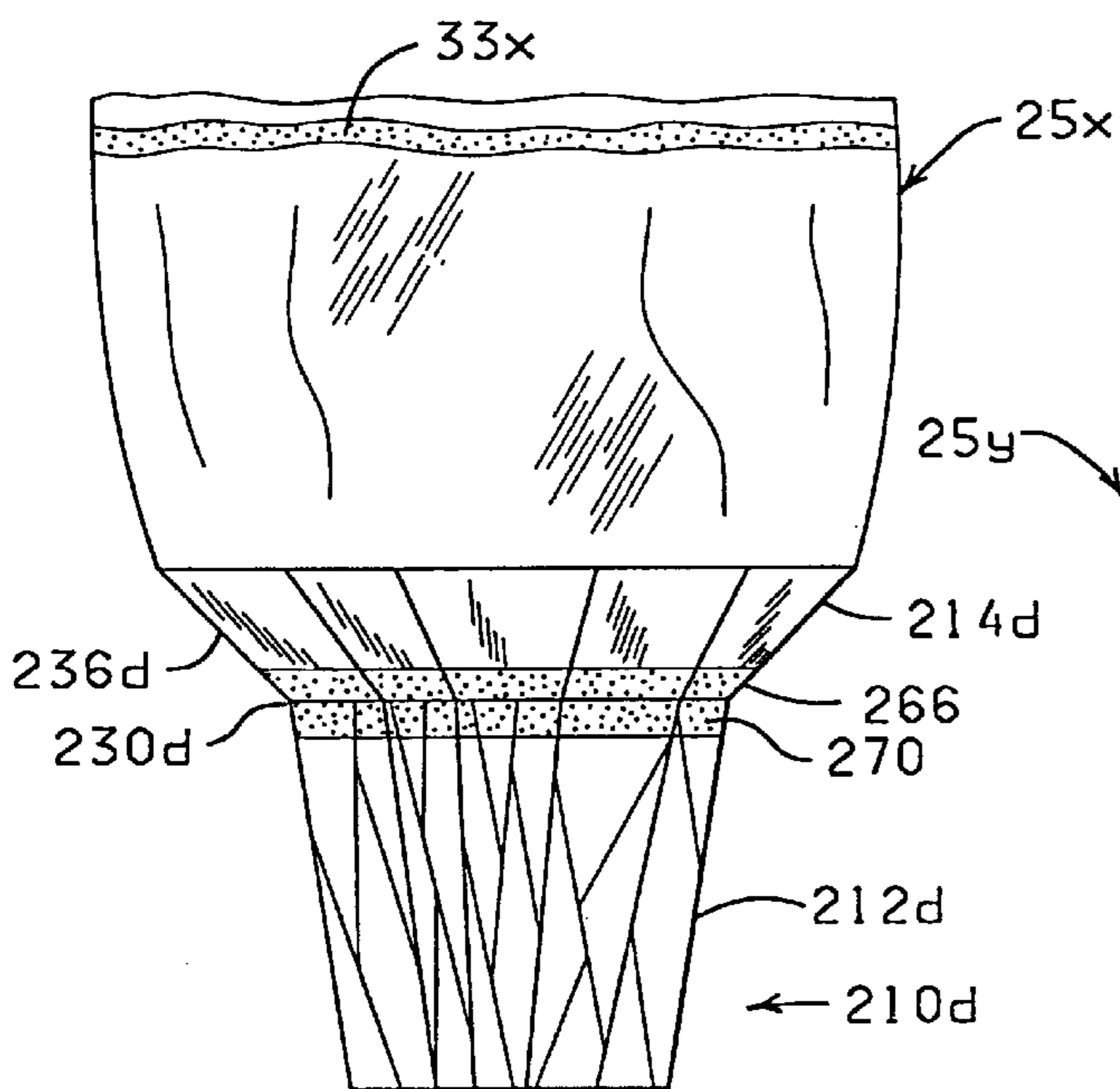
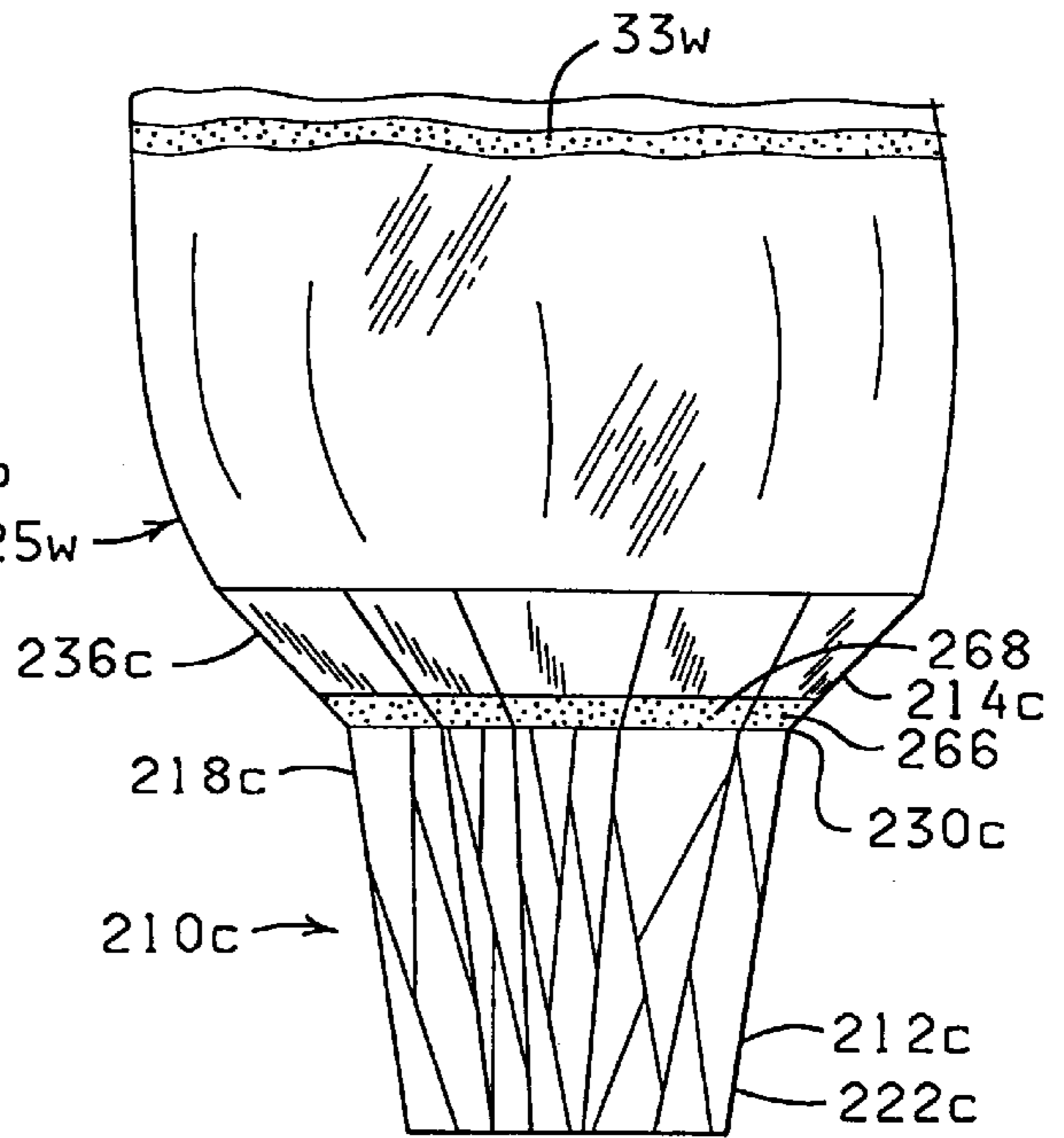
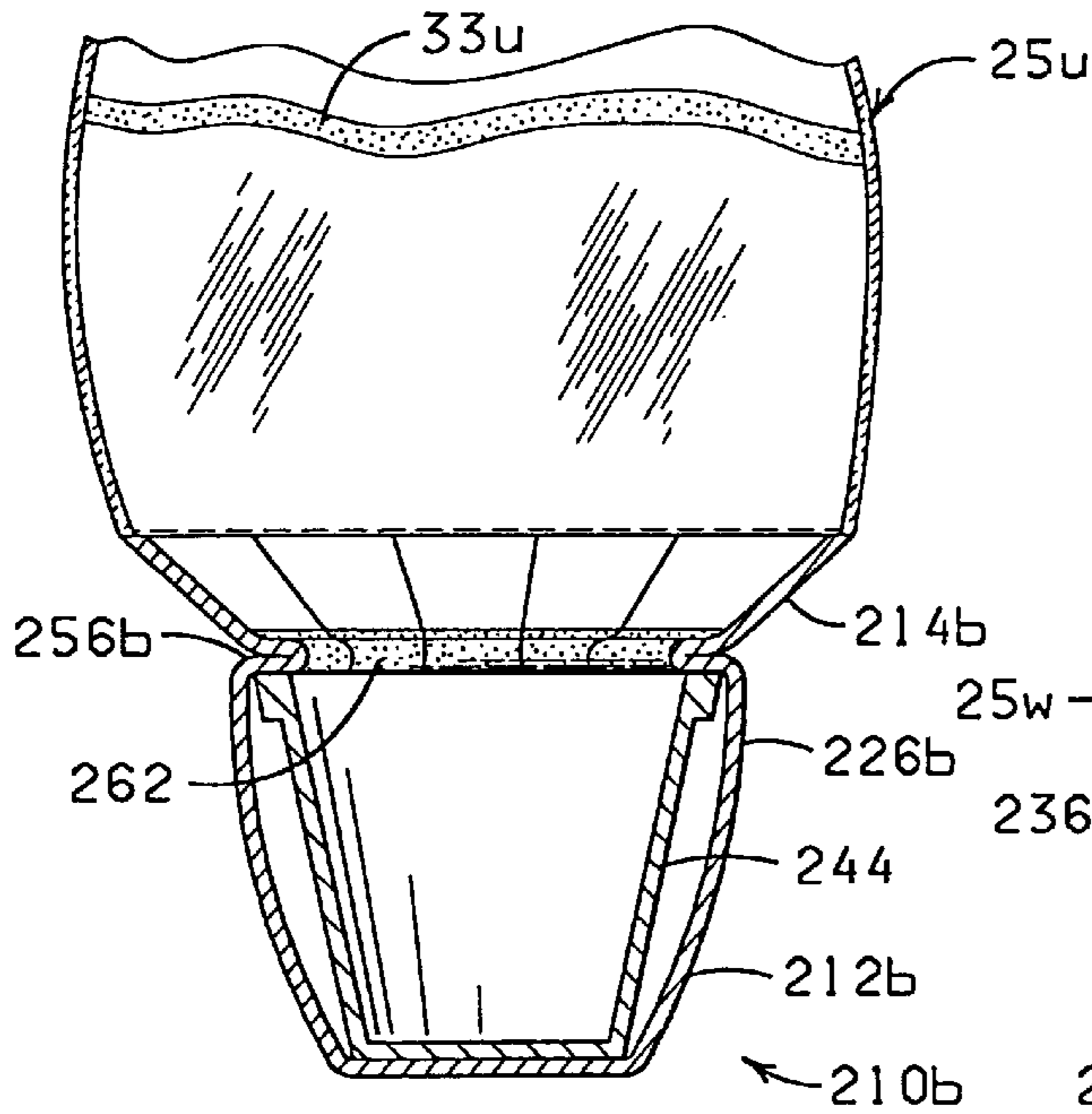

FIG. 36



METHOD OF COVERING A FLOWER POT AND FLORAL GROUPING

This is a continuation of U.S. Ser. No. 08/846,441, filed Apr. 30, 1997, now U.S. Pat. No. 5,815,905 which is a continuation of U.S. Ser. No. 08/468,502, filed Jun. 6, 1995, now U.S. Pat. No. 5,625,937, which is a continuation of U.S. Ser. No. 08/037,067, filed Mar. 25, 1995, now U.S. Pat. No. 5,542,169, which is a continuation-in-part of U.S. Ser. No. 07/926,098, filed Aug. 5, 1992, now U.S. Pat. No. 5,809,629; said U.S. Ser. No. 08/037,067, also a continuation-in-part of U.S. Ser. No. 07/940,930, filed Sep. 4, 1992, now U.S. Pat. No. 5,361,482.

FIELD OF THE INVENTION

The present invention relates generally to coverings for flower pots and floral groupings and, more particularly, but not by way of limitation, to a covering having a portion extending about a flower pot for providing a decorative covering and another portion extending about the floral grouping disposed in the flower pot for providing a protective covering for the floral grouping.

BRIEF DESCRIPTION OF THE DRAWINGS

FIG. 1 is a plan view showing the upper surface of a sheet of material with a sheet extension connected thereto constructed in accordance with the present invention.

FIG. 2 is a sectional view showing the sheet of material of FIG. 1 formed about a flower pot and the sheet extension formed about a floral grouping to provide a protective covering.

FIG. 3 is an elevational view showing the sheet of material formed about the flower pot as shown in FIG. 2 with the flower pot not being shown in FIG. 3 and showing the sheet extension wrapped about the floral grouping.

FIG. 4 is a sectional view of a portion of the sheet of material crimped to form an overlapping fold.

FIG. 5 is a plan view of the lower surface of a modified sheet of material having a sheet extension connected thereto.

FIG. 6 is a sectional view showing a portion of the sheet of material of FIG. 5 crimped to form an overlapping fold.

FIG. 7 is a sectional view showing a sheet of material wrapped about a flower pot to form a modified decorative covering and showing the sheet extension formed about a floral grouping to provide a protective covering.

FIG. 8 is a plan view of the upper surface of another modified sheet of material and showing a modified sheet extension connected thereto.

FIG. 9 is a sectional view of the sheet of material and sheet extension of FIG. 8.

FIG. 10 is a plan view of the upper surface of yet another modified sheet of material with a sheet extension connected thereto.

FIG. 11 is a sectional view showing the modified sheet of material of FIG. 10 formed about a flower pot and the sheet extension formed about a floral grouping.

FIG. 12 is a plan view of the upper surface of still another modified sheet of material with a modified sheet extension connected thereto.

FIG. 13 is a sectional view of the sheet of material and the sheet extension of FIG. 12.

FIG. 14 is a plan view of the upper surface of still another modified sheet of material with a modified sheet extension connected thereto.

FIG. 15 is a sectional view of the sheet of material and the sheet extension of FIG. 14.

FIG. 16 is a plan view of the lower surface of still another modified sheet of material with a sheet extension connected thereto.

FIG. 17 is a sectional view of the sheet of material of FIG. 16 formed about a flower pot and the sheet extension formed about a floral grouping.

FIG. 18 is an end elevational view of a pad of sheets of material with sheet extension connected thereto constructed in accordance with the present invention.

FIG. 19 is a diagrammatic, end elevational view of a roll of material for providing sheets of material with sheet extension connected thereto in accordance with the present invention.

FIG. 20 is a perspective view of the roll of material for providing sheets of material with sheet extension connected thereto in accordance with the present invention.

FIG. 21 is a plan view of the upper surface of yet another modified sheet of material with a sheet extension connected thereto.

FIG. 22 is a sectional view showing the sheet of material of FIG. 21 formed about a flower pot and the sheet extension formed about a floral grouping.

FIG. 23 is a sectional view of the sheet of material of FIG. 21 wrapped about a flower pot with the section taken along the horizontal plane as compared to the section taken along the vertical plane shown in FIG. 22.

FIG. 24 is an elevational view of a modified flower pot for cooperating to connect the sheet of material thereto.

FIG. 25 is a sectional view showing a sheet of material wrapped about a flower pot for forming yet another modified decorative cover with a sheet extension connected thereto.

FIG. 26 is a perspective view of a modified flower pot for cooperating to secure a sheet of material wrapped thereabout to form a modified decorative cover like the decorative cover shown in FIG. 25.

FIG. 27 is a plan view of the lower surface of still another modified sheet of material having a ribbon connected thereto and showing a sheet extension connected thereto with a ribbon connected to the sheet extension.

FIG. 28 is a sectional view of the modified sheet of material with the sheet extension connected thereto shown in FIG. 27.

FIG. 29 is a front elevational view of the sheet of material of FIG. 27 wrapped about a flower pot (not shown) to form another modified decorative covering and the sheet extension formed about the floral grouping to provide a protective covering.

FIG. 30 is a sectional view of a flower pot with a floral grouping disposed therein and showing a sheet of material wrapped about the flower pot and secured thereto with a band, the sheet of material having a sheet extension connected thereto formed about the floral grouping for providing a protective covering.

FIG. 31 is a perspective view of a flower pot cover with a sheet extension constructed in accordance with the present invention.

FIG. 32 is an elevational view of the flower pot cover of FIG. 1 with the sheet extension connected thereto.

FIG. 33 is a sectional view of a flower pot with the flower pot cover of FIGS. 1 and 2 placed thereabout and with a crimped portion formed in the flower pot cover and with the sheet extension connected thereto.

FIG. 34 is a perspective view of a modified flower pot cover with a sheet extension connected thereto constructed in accordance with the present invention.

FIG. 35 is a sectional view showing the flower pot cover of FIG. 34 placed about a flower pot with the flower pot cover having a crimped portion formed therein, the flower pot cover having the sheet extension connected thereto.

FIG. 36 is a perspective view of yet another modified flower pot cover with a sheet extension connected thereto.

FIG. 37 is a sectional view showing the flower pot cover of FIG. 36 disposed about a flower pot with a crimped portion being formed in the flower pot cover and showing the sheet extension formed about the floral grouping.

FIG. 38 is an elevational view of still another modified flower pot cover with the sheet extension connected thereto.

FIG. 39 is an elevational view of still another modified flower pot cover with the sheet extension connected thereto.

FIG. 40 is an elevational view of still another modified flower pot cover with a sheet extension connected thereto.

DESCRIPTION OF THE PREFERRED EMBODIMENTS

Shown in FIG. 1 and designated by the general reference number 10 is a sheet of material constructed in accordance with the present invention.

The sheet of material 10 includes a first end 12, a second end 14, a first side 16 and a second side 18. The sheet of material 10 also includes an upper surface 20 (FIG. 1) and a lower surface 22 (FIG. 2).

A connecting bonding material 24 is disposed on the upper surface 20 of the sheet of material 10. The sheet of material 10 has an outer peripheral edge 26. The connecting bonding material 24 is disposed near and spaced a distance 28 from the outer peripheral edge 26 of the sheet of material 10 and extends generally circumferentially about the sheet of material 10.

The sheet of material 10 shown in FIG. 1 generally is circularly shaped and the connecting bonding material 24 extends in a circularly shaped pattern over a portion of the upper surface 20 of the sheet of material 10. The sheet of material 10 may be any geometric shape such as square or rectangular or heart shaped or trapezoidally shaped or any other geometric shape. Further, the connecting bonding material 24 may extend in any geometric pattern over the upper surface 20 of the sheet of material 10, and the circularly shaped pattern is shown in FIG. 1 only by way of example.

A sheet extension 25 is connected to the sheet of material 10. The sheet extension 25 extends about the outer peripheral edge 26 of the sheet of material 10. The sheet extension 25 extends outwardly from the sheet of material 10 terminating with an outer peripheral edge 27. The sheet extension 25 has an upper surface 29 (FIG. 1) and a lower surface 31 (FIG. 2). The upper surface 29 is disposed in a plane about coplanar with the upper surface 20 of the sheet of material 10 and lower surface 31 is disposed in a plane about coplanar with the lower surface 22 of the sheet of material 10.

The sheet extension 25 and the sheet of material 10 may be integrally constructed of a single sheet of material or the sheet extension 25 may be laminated to the sheet of material 10. A connecting bonding material 33 is disposed on the upper surface 29 of the sheet extension 25. The connecting bonding material 33 is disposed near and spaced a distance from the outer peripheral edge 27 of the sheet extension 25 and extends generally circumferentially about the sheet extension 25.

The sheet extension 25 is shown in FIG. 1 as being circularly shaped. The sheet extension 25 may be any geometric shape such as a square or rectangular or heart shaped or trapezoidally shaped or any other geometric shape and the geometric shape of the sheet extension 25 may be the same as the geometric shape of the sheet of material 10 or the sheet extension 25 may have a geometric shape different from the geometric shape of the sheet of material 10. Further, although the sheet extension 25 is shown in FIG. 1 as extending circumferentially about the outer peripheral surface 26 of the sheet of material 10, the sheet extension 25 may extend only about a portion of the outer peripheral edge 26 of the sheet of material 10 or the sheet extension 25 may comprise segments with each segment extending about a portion of the outer peripheral edge 26 of the sheet of material 10.

The sheet of material 10 and the other sheets of material and the sheet extension 25 and the other sheet extensions described herein are constructed from any suitable flexible material that is capable of being wrapped or formed about a flower pot or a floral grouping as described herein. Preferably, the sheet of material 10 and the sheet extension 25 are constructed of a material selected from a group of materials consisting of paper, metal foil, cloth (natural or synthetic or combinations thereof), denim, burlap or polymer film or combinations thereof.

The term "polymer film" as used herein means any polymer film. For example, but not by way of limitation, one polymer film is a polypropylene film. Another example of a polymer film, but not by way of limitation, is cellophane.

The sheet of material 10 and the sheet extension 25 each have a thickness in a range from about 0.1 mils to about 30 mils. Preferably, the sheet of material 10 and the sheet extension 25 each have a thickness in a range from about 0.1 mils to about 5 mils.

The sheet of material 10 and the sheet extension 25 may be constructed of a single layer of material or a plurality of layers of the same or different types of materials. Any thickness of the sheet of material 10 and the sheet extension 25 may be utilized in accordance with the present invention as long as the sheet of material 10 and the sheet extension 25 are wrappable or formable about a flower pot or a floral grouping in the manners described herein. The layers of material comprising the sheet of material 10 and the sheet extension 25 may be connected together or laminated or may be separate layers.

A decorative pattern, such as a color and/or an embossed pattern, and/or other decorative surface ornamentation may be applied to the upper surface 20 and/or the lower surface 22 of the sheet of material 10 or portions thereof including, but not limited to printed design, coatings, colors, flocking or metallic finishes. The sheet of material 10 also may be totally or partially clear or tinted transparent material.

A decorative pattern, such as a color and/or an embossed pattern, and/or other decorative surface ornamentation may be applied to the upper surface 29 and/or the lower surface 31 of the sheet extension 25 or portions thereof including, but not limited to, printed design, coatings, colors, flocking or metallic finishes. The sheet extension 25 also may be totally or partially clear or tinted transparent material. In one preferred embodiment the sheet of material 10 has a decorative pattern applied to the upper surface 20 and/or the lower surface 22 while the sheet extension is totally or partially clear or tinted transparent. The sheet extension 25 is shown in the drawings as being transparent.

The term "bonding material" as used herein means an adhesive, preferably a pressure sensitive adhesive, or a

cohesive. Where the bonding material is a cohesive, a similar cohesive material must be placed on the adjacent surface for bondingly contacting and bondingly engaging with the cohesive material. The term "bonding material" also includes materials which are heat sealable and, in this instance, the adjacent portions of the material must be brought into contact and then heat must be applied to effect the seal. The term "bonding material" as used herein also means a heat sealing lacquer which may be applied to the sheet of material and, in this instance, heat also must be applied to effect the sealing. The term "bonding material" as used herein means any type of material or thing which can be used to effect the bonding or connecting of the two adjacent portions of the sheet of material **10** to effect the connection or bonding described herein. The term "bonding material" also includes other forms of effecting the bonding described herein such as chemical welds or heat fusion or welding by way of example only.

The connecting bonding materials **24** and **33** are shown in FIG. 1 as being applied to the upper surface **20** of the sheet of material **10** or the upper surface **29** of the sheet extension **25** in the form of a circularly shaped strip. The connecting bonding materials **24** or **33** may be applied in the form of spots or spaced apart strips and the spots may be any geometric pattern or any other type of pattern such as a logo for example. Further, the connecting bonding materials **24** or **33** may include a color to obscure the fact that the connecting bonding materials **24** and **33** are disposed on the sheet of material **10** or the sheet extension **25**.

Shown in FIG. 2 is a flower pot **30** having an upper end **32**, a lower end **34** and an outer peripheral surface **36**. An opening **38** is formed through the upper end **32** of the flower pot **30** providing access to a retaining space **40**. The retaining space **40** is sized to accommodate growing medium such as soil for example and at least a portion of a botanical item such as a plant or flower for example.

The retaining space **40** forms an inner peripheral surface **42** in the flower pot **30**. A bottom **44** of the flower pot **30** is disposed at the lower end **34** and cooperates to enclose or partially enclose the retaining space **40**. The flower pot **30** may be any conventional, commercially available container well known in the art.

Growing medium **45** is shown in FIG. 2 disposed in the retaining space **40** and a floral grouping **47** is shown in FIG. 2 partially disposed in the growing media **45**. A portion of the floral grouping **47** extends a distance upwardly above the upper end **32** of the flower pot **30**.

"Floral grouping" as used herein means any botanical item such as flowers or plants or trees or the like, or a single flower or a single plant or a single tree or the like, and may include other floral materials and may include other secondary plants and/or ornamentation which add to the aesthetics of the overall floral grouping. The botanical item may be a growing flower, plant or tree or the like, or may be an artificial flower plant or tree or the like.

The flower pot **30** is placed on the upper surface **20** of the sheet of material **10**. More particularly, the bottom **44** of the flower pot **30** is disposed on a central portion of the sheet of material **10**. In this position, the connecting bonding material **24** extends circumferentially about the flower pot **30** and the connecting bonding material **24** is spaced a distance from the flower pot **30**.

The sheet of material **10** then is formed about the flower pot **30** to a position wherein the sheet of material **10** extends about and encompasses substantially the entire outer peripheral surface **36** of the flower pot **30**, including the bottom **44**.

It should be noted that the sheet of material **10** does not have to cover the bottom **44**. In this position, a portion of the sheet of material **10** is disposed adjacent the bottom **44** of the flower pot **30** and portions of the sheet of material **10** extend upwardly and encompass the entire outer peripheral surface **36** of the flower pot **30** between the upper end **32** and the lower end **34** of the flower pot **30**. In one embodiment, the portions of the sheet of material **10** extending over the outer peripheral surface **36** are spaced a distance from the outer peripheral surface **36** of the flower pot **30** to provide a blossom type affect.

When the sheet of material **10** is formed about the flower pot **30**, a portion of the sheet of material **10** near the outer peripheral surface **36** thereof extends a distance above the upper end **32** of the flower pot **30** as shown in FIG. 2. Further, when the sheet of material **10** is formed about the flower pot **30**, the sheet of material **10** is sized and the connecting bonding material **24** is positioned on the upper surface **20** of the sheet of material **10** so that the connecting bonding material **24** is disposed a distance above the upper end **32** of the flower pot **30**.

In this position, the portion of the sheet of material **10** disposed near and about the connecting bonding material **24** is crimped by bringing together portions of the sheet of material **10** near and about the connecting bonding material **24** so that portions of the sheet of material **10** near and about the connecting bonding material **24** are disposed adjacent each other and the adjacent portions of the sheet of material **10** are connected by way of the connecting bonding material **24** thereby forming a plurality of overlapping folds **49** in the portion of the sheet of material **10** near and about the connecting bonding material **24**. The connected overlapping folds **49** extend at various distances and at various angles. The connected overlapping folds **49** (FIGS. 2 and 3) in the area near and about the portion of the sheet of material **10** containing the connecting bonding material **24** is designated in FIG. 2 by the reference numeral **46** and sometimes referred to herein as the crimped portion **46** (FIGS. 2 and 3).

A typical section showing a portion of a typical overlapping fold **49** is shown in FIG. 4. The adjacent portions of the sheet of material **10** on the upper surface **20** are shown in FIG. 4 as being connected while the adjacent portions of the sheet of material **10** on the lower surface **22** are unconnected since no bonding material is disposed on the lower surface **22**. It should be noted that connecting bonding material also can be disposed on the lower surface **22** for connecting adjacent portions of the lower surface **22** in the crimped portion **46** if desired and as described in more detail below.

The crimped portion **46** extends circumferentially about the upper end **32** of the flower pot **30**. The crimped portion **46** also extends a distance inwardly from the upper end **32** of the flower pot **30** toward a central portion of the retaining space **40** thereby forming a ridge portion **48** extending circumferentially about the flower pot **30** generally near the upper end **32** of the flower pot **30**. The crimped portion **46** and the ridge portion **48** thereof cooperate to engage the upper end **32** of the flower pot **30** to assist and cooperate in holding the sheet of material **10** formed about the flower pot **30** to provide a decorative cover **50** (FIGS. 2 and 3).

The crimped portion **46** when formed preferably causes adjacent portions of the upper and lower surfaces **20** and **22** of the sheet of material **10** to be brought together or positioned adjacent each other. The crimped portion **46** and the other crimped portions shown in the drawings are shown in an expanded form where the portions of the lower surface **22** are not disposed adjacent each other for the purpose of

illustration and because this expanded form may be desired in some applications.

The portion of the sheet of material **10** extending between the connecting bonding material **24** and the outer peripheral edge **26** of the sheet of material **10** extends a distance above the crimped portion **46** and is flared outwardly and extends a distance radially outwardly from the crimped portion **46** to form a flared portion **52**. The flared portion **52** extends circumferentially about the decorative cover **50** and circumferentially about the upper end **32** of the flower pot **30**.

In this embodiment, the connecting bonding material **24** preferably is a pressure sensitive adhesive or a cohesive, although the connecting bonding material **24** could be in any of the other forms described before.

The upper surface **20** of the sheet of material **10** forms the inner peripheral surface of the decorative cover **50** and the lower surface **22** of the sheet of material **10** forms the outer peripheral surface of the decorative cover **50**. The inner peripheral surface of the decorative cover **50** formed by the upper surface **20** of the sheet of material **10** is disposed adjacent the bottom **44**. The inner peripheral surface of the decorative cover **50** formed by the upper surface **20** is spaced a distance from the outer peripheral surface **36** of the flower pot **30**.

As described above, the flower pot **30** was placed on the upper surface **20** of the sheet of material **10** and then formed about the sheet of material **10** to form the decorative cover **50** with the upper surface **20** being disposed near the outer peripheral surface **36** of the flower pot **30** and the lower surface **22** providing the outer surface of the decorative cover **50**. In the alternative, the flower pot **30** may be placed on the lower surface **22** of the sheet of material **10**. In this last-mentioned embodiment, the sheet of material **10** is formed about the flower pot **30** in the manner exactly like that described before, except the lower surface **22** is disposed near the outer peripheral surface **36** of the flower pot **30** and the upper surface **20** forms the outer surface of the decorative cover **50** with the connecting bonding material **24** being disposed on the outer surface of the decorative cover **50**.

Either before or after or during the forming of the crimped portion **46**, the sheet extension **25** is formed about the floral grouping **47** to a position wherein the sheet extension **25** encompasses a substantial portion of the floral grouping **47**, as shown in FIGS. **2** and **3**. The sheet extension **25** extends upwardly about the floral grouping **47** with a portion of the sheet extension **25** extending upwardly beyond the upper end of the floral grouping **47** terminating with the outer peripheral surface **27** of the sheet extension **25** and forming an open upper end. In this position of the sheet extension **25**, portions of the sheet extension **25** near the outer peripheral edge **27** (the open upper end) thereof are brought into contact thereby bringing the bonding material **33** into contact and engagement with adjacent portions of the sheet extension **25** for closing the sheet extension **25** about or above an upper end of the floral grouping **47**.

In a preferred form, a line of perforations **53** (FIGS. **1** and **3**) is formed between the sheet of material **10** and the sheet extension **25**. The line of perforations **53** extends generally about the outer peripheral edge **26** of the sheet of material **10**. The sheet extension **25** encompasses the floral grouping **47** and provides a protective covering for the floral grouping **47** to protect the floral grouping **47** during shipment and/or storage. When it is desired to remove the protective covering provided by the sheet extension **25**, the operator tears the sheet extension **25** along the line of perforations **53** thereby

severing or separating the sheet extension **25** from the sheet of material **10** so that the sheet extension **25** can be removed from the sheet of material **10** or, in other words, the protective covering may be removed from the decorative covering by tearing along the line of perforations **53**.

EMBODIMENT OF FIGS. **5** AND **6**

Shown in FIG. **5** is a modified sheet of material **10a** which is constructed exactly like the sheet of material **10** shown in FIG. **1** and described in detail before, except the sheet of material **10a** includes a cohesive or pressure sensitive adhesive connecting bonding material **54** disposed on the lower surface **22a** of the sheet of material **10a**. The cohesive or pressure sensitive adhesive connecting bonding material **54** extends circumferentially about the lower surface **22a**. The cohesive or pressure sensitive adhesive connecting bonding material **54** is spaced a distance **56** from the outer peripheral edge **26a** of the sheet of material **10a**. Preferably, the distance **56** corresponds or equals the distance **28** described before in connection with the sheet of material shown in FIG. **1**.

The sheet of material **10a** includes the connecting bonding material **54** (preferably a pressure sensitive adhesive or cohesive connecting bonding material) on the upper surface **20a** of the sheet of material **10a** exactly like that described before in connection with the sheet of material **10** shown in FIG. **1**.

The sheet extension **25a** is constructed exactly like the sheet extension **25** shown in FIGS. **1** through **3** and described in detail before, except the sheet extension **25a** includes the connecting bonding material **33a** disposed on the lower surface **31a** of the sheet extension **25a**.

In this embodiment, the sheet of material **10a** is formed about the flower pot **30** in a manner exactly like that described before in connection with the sheet of material **10** formed about the flower pot **30** as shown in FIG. **2**, except in this embodiment, when the crimped portion like the crimped portion **46** (FIG. **2**) is formed, the adjacent portions of the sheet of material **10a** in the area containing the connecting bonding material **54** also will be bondingly connected (FIG. **6**). Thus, in this embodiment, the adjacent portions of the sheet of material **10a** on the upper surface **20a** and the lower surface **22a** are bondingly connected by way of the respective connecting bonding material **24** or the cohesive connecting bonding material **54**.

The sheet extension **25a** is formed about the floral grouping **47** in a manner exactly like that described before in connection with FIGS. **1** through **3**, except the bonding material **33a** on the lower surface **31a** is brought into bonding engagement with adjacent portions of the sheet extension **25a** to close the open upper end of the protective covering provided by the sheet extension **25a**.

EMBODIMENT OF FIG. **7**

Shown in FIG. **7** is another modified sheet of material **10b** which is constructed exactly like the sheet of material **10** shown in FIGS. **1-4** and described in detail before, except, in this embodiment, the crimped portion **46b** extends a distance radially outwardly and circumferentially about the upper end **32** of the flower pot **30**. The sheet of material **10b** is formed about the flower pot **30** in the manner exactly like that described before with respect to the sheet of material **10** shown in FIGS. **1-4** and described in detail before, except the crimped portion **46b** is formed to extend radially outwardly as opposed to radially inwardly in the manner described before in connection with the sheet of material **10** in the crimped portion **46** (FIGS. **1-4**).

It should be noted that in connection with the sheet of material **10**, **10a** or **10b**, the bottom **44** of the flower pot **30** may be placed on the lower surface **22** and the sheet of material **10**, **10a** or **10b** and then formed about the flower pot **30** in the manner described before with the upper surface **20** forming the outer peripheral surface of the decorative cover **50** in lieu of the lower surface **22** forming the outer peripheral surface of the decorative cover **50** in the manner described before in connection with the embodiments shown in FIGS. 1-7.

The sheet extension **25b** is constructed exactly like the sheet extension **25** shown in FIGS. 1 through 4 and described in detail before.

EMBODIMENT OF FIGS. 8 AND 9

Shown in FIGS. 8 and 9 is another modified sheet of material **10c** which is constructed exactly like the sheet of material **10** shown in FIGS. 1-4 and described in detail before, except the sheet of material **10c** does not include the connecting bonding material **24**. The sheet of material **10c** includes a drawstring **58**. The drawstring **58** is connected to the sheet of material **10c**. The drawstring **58** has opposite ends **60** and **62**. Portions of the drawstring **58** near each of the opposite ends **60** and **62** thereof exit through respective openings **64** and **66** formed in the upper surface **20c** of the sheet of material **10c**.

The drawstring **58** extends circumferentially about the sheet of material **10c** and the drawstring **58** is spaced a distance **68** from the outer peripheral edge **26** of the sheet of material **10c**.

The drawstring **58** may be connected to the sheet of material **10c** in any suitable manner so desired in any particular application. In one preferred embodiment, the sheet of material **10c** comprises a first sheet **70** and a second sheet **72** (FIG. 9). The drawstring **58** is disposed between the first and the second sheets **70** and **72** and the first and the second sheets **70** and **72** then are bondingly connected or laminated to form the sheet of material **10c**. Portions of the first and the second sheets **70** and **72** near the drawstring **58** are left unconnected so that the drawstring **58** may slidingly move between the first and the second sheets **70** and **72**. The openings **64** and **66** more particularly are formed through a portion of the first sheet **70**. The first and the second sheets **70** and **72** are constructed of materials exactly like that described before with respect to the sheet of material **10**.

The sheet extension **25c** is constructed exactly like the sheet extension **25** shown in FIGS. 1 through 4 and described in detail before, except the sheet extension **25** does not include the connecting bonding material **33**, although it could also include bonding material if desired.

The sheet extension **25c** includes a drawstring **57**. The drawstring **57** is connected to the sheet extension **25c**. The drawstring **57** has opposite ends **59** and **61**. Portions of the drawstring **57** near each of the opposite ends **59** and **61** exit through respective openings **63** and **65** formed in the upper surface **29c** of the sheet extension **25c**.

The drawstring **57** extends circumferentially about the sheet extension **25c**. The drawstring **57** is spaced a distance from the outer peripheral surface **27c** of the sheet extension **25c**.

The drawstring **57** may be connected to the sheet extension **25c** in any suitable manner so desired in any particular application. In one preferred embodiment, the sheet extension **25c** is formed by extending the first and the second sheets **70** and **72** (FIG. 9). The drawstring **57** is disposed between the first and the second sheets **70** and **72** and the

first and the second sheets then are bondingly connected or laminated to form the sheet of material **10c** and the sheet extension **25c**. Portions of the first and the second sheets **70** and **72** near the drawstring **57** are left unconnected so the drawstring may slidingly move between the first and the second sheet **70** and **72**. The opening **63** and **65** more particularly are formed through a portion of the first sheet **70**.

The sheet of material **10c** is formed about the flower pot **30** in the manner exactly like that described before with respect to the sheet of material **10** shown in FIGS. 1-4 and described in detail before. The drawstring **58** is positioned on the sheet of material **10c** and the sheet of material **10c** is sized and shaped so that, when the sheet of material **10c** is formed about the flower pot **30**, the drawstring **58** is disposed above the upper end **32** of the flower pot **30**. In this position, the ends **60** and **62** of the drawstring **58** are pulled thereby drawing the portions of the sheet of material **10c** generally near the drawstring **58** inwardly and crimping the portions of the sheet of material near the drawstring **58** to form the crimped portion like the crimp portion **46** shown in FIGS. 2 and 3. The ends **60** and **62** of the drawstring **58** then are tied or otherwise secured to maintain the crimped portion formed in the decorative covering formed by the sheet of material **10c**.

The sheet extension **25c** is formed about the floral grouping **47** to a position wherein the sheet extension **25c** extends about a substantial portion of the floral grouping **47**. In this position, the ends **59** and **61** of the drawstring **57** are pulled thereby drawing portions of the sheet extension **25c** generally near the drawstring **57** inwardly closing the open upper end of the sheet extension **25c** about the floral grouping. The ends **61** and **59** then are tied or otherwise secured to maintain the sheet extension **25c** extending about the floral grouping to provide the protective covering. The sheet extension **25c** may be separated from the decorative cover formed by the sheet of material **10c** by tearing along the line of perforations **53c**.

The decorative covering formed by the sheet of material **10c** will look like the decorative covering **50** shown in FIGS. 2 and 3, except the crimped portion **46** is formed by pulling the drawstring **58** and the resulting adjacent portions of the sheet of material **10c** are not bondingly connected in the manner described before with respect to the decorative cover **50**. It should be noted that the sheet of material **10c** also could include a cohesive or pressure sensitive adhesive bonding material on the upper surface **20c** of the sheet of material **10c** exactly like that described before with respect to the connecting bonding material **24** on the sheet of material **10** (FIGS. 1-4). In this embodiment, the adjacent portions of the sheet of material **10c** formed when the drawstring **58** is pulled to form the crimped portion, also would be bondingly connected in a manner like that described before with respect to the decorative cover **50** and the crimped portion **46** (FIGS. 1-4). Also, the sheet of material **10c** can be constructed like the sheet of material **10a** shown in FIGS. 5 and 6 and described in detail before so that the adjacent portions of the lower surface **22c** also are connected when the drawstring **58** is pulled to form the crimped portion.

EMBODIMENT OF FIGS. 10 AND 11

Shown in FIGS. 10 and 11 is a modified sheet of material **10d** which is constructed exactly like the sheet of material **10** shown in FIGS. 1-4 and described in detail before, except the sheet of material **10d** also includes a pot connecting

bonding material **80** disposed on the upper surface **20d** of the sheet of material **10d**. The pot connecting bonding material **80** extends circumferentially about the sheet of material **10d**. The pot connecting bonding material **80** is spaced a distance **82** from the outer peripheral edge **26d** of the sheet of material **10d** and the distance **82** is greater than the distance **83** between the connecting bonding material **24d** and the outer peripheral edge **26d**. The pot connecting bonding material **80** is spaced a distance **84** from the connecting bonding material **24d**.

The sheet of material **10d** is formed about the flower pot **30** in a manner exactly like that described before in connection with the sheet of material **10** shown in FIGS. 1-4, except, in this embodiment, the pot connecting bonding material **80** is positioned on the sheet of material **10d** so that, when the sheet of material **10d** is formed about the flower pot **30**, the pot connecting bonding material **80** is disposed near the outer peripheral surface **36** and near the upper end **32** of the flower pot **30**. In this position, the portions of the sheet of material **10d** having the pot connecting bonding material **80** disposed thereon are pressed or positioned against the outer peripheral surface **36** of the flower pot **30** so that the pot connecting bonding material **80** bondingly engages and bondingly connects a portion of the sheet of material **10d** to the outer peripheral surface **36** of the flower pot **30** generally near and adjacent the upper end **32** of the flower pot **30** for bonding a portion of the sheet of material **10d** to the flower pot **30**.

The sheet of material **10d** thus is bonded to the flower pot **30** by way of the pot connecting bonding material **80** and the connection between the sheet of material **10d** and the flower pot **30** extends circumferentially about the flower pot **30** generally near and adjacent the upper end **32** thereof.

In this embodiment, the crimped portion **46d** and the ridge portion **48d** cooperate to secure the sheet of material **10d** in the form of the decorative cover **50d** formed about the flower pot **30** and the pot connecting bonding material **80** also cooperates to maintain the sheet of material **10d** in the form of the decorative cover **50d** positioned about the flower pot **30**. The pot connecting bonding material **80** thus augments the crimped portion **46d** and the ridge portion **48d** in maintaining the sheet of material **10d** in the form of the decorative cover **50d** secured about the flower pot **30**.

The sheet of material **10d** also could be constructed like the sheet of material **10a** if desired. The sheet of material **10d** also could be constructed like the sheet of material **10b** to form the decorative cover **50b** in a manner like that described before with respect to FIG. 7 if desired in a particular application. The sheet of material **10d** also could include the drawstring in the manner described before with respect to the drawstring **58** shown in FIGS. 8 and 9 if desired in a particular application.

The sheet of material **10d** is connected to the sheet extension **25d** and the sheet extension **25d** is constructed exactly like the sheet extension **25** shown in FIGS. 1 through 4 and described in detail before. The sheet extension **25d** is formed about the floral grouping **47** to provide the protective covering in the manner exactly like that described before in connection with FIGS. 1 through 4. The sheet extension **25d** is shown in FIG. 11 formed about the floral grouping **47**.

EMBODIMENT OF FIGS. 12 AND 13

Shown in FIGS. 12 and 13 is another modified sheet of material **10e**, which is constructed exactly like the sheet of material **10** shown in FIGS. 1-4 and described in detail before, except the sheet of material **10e** does not necessarily

include the connecting bonding material like the connecting bonding material **24** on the sheet of material **10** shown in FIGS. 1-4. The sheet of material **10e** includes reinforcing means **86** connected to the sheet of material **10e**. The reinforcing means **86** more particularly comprises a plurality of reinforcing elements with two reinforcing elements **88** and **90** being shown in FIGS. 12 and 13 by way of example. Each of the reinforcing elements **88** and **90** are connected to the sheet of material **10e**. The reinforcing elements **88** and **90** each extend circumferentially about the sheet of material **10e**. The reinforcing elements **88** and **90** are spaced about a distance **92** from the outer peripheral surface **26e** of the sheet of material **10e**.

The reinforcing elements **88** and **90** may be connected to the sheet of material **10e** in any suitable manner. Preferably, the sheet of material **10e** is formed using a first sheet **94** and a second sheet **96** (FIG. 13) with the reinforcing elements **88** and **90** being disposed between the first and the second sheets **94** and **96**. In this position, the first and the second sheets **94** and **96** are bondingly connected or laminated together to form the sheet of material **10e**. The first and the second sheets **94** and **96** are constructed of any of the materials described before in connection with the sheet of material **10** shown in FIGS. 1-4.

In this embodiment, the sheet of material **10e** is formed about the flower pot **30** in the manner exactly like that described before in connection with the sheet of material **10** shown in FIGS. 1-4, except the crimped portion is maintained in the formed position by way of the reinforcing elements **88** and **90** which cooperate to maintain the portion of the sheet of material **10e** in a crimped position to form the crimped portion such as the crimped portion **46** shown in FIGS. 2 and 3 and described in detail before.

The reinforcing elements **88** and **90** may be constructed of any type of material capable of maintaining the shape of the crimped portion of the decorative cover like the crimped portion **46** of the decorative cover **50** described before. The reinforcing elements **88** and **90** may be wire elements for example or plastic rods and the reinforcing elements **88** and **90** may be continuous as illustrated in FIG. 12 or in the form of segments as may be desired in a particular application.

It also should be noted that the sheet of material **10e** can be formed about the flower pot **30** to provide a decorative covering like the decorative covering **50b** shown in FIGS. 7 and described in detail before. It also should be noted that the sheet of material **10e** may include connecting bonding material like the connecting bonding material **24** and/or connecting bonding material like the connecting bonding material **54** if desired in a particular application. In some instances, it also may be desirable to include a drawstring with the sheet of material **10e** like the drawstring **58** shown in FIGS. 8 and 9 and described in detail before. It also should be noted that the sheet of material **10e** may include pot connecting bonding material like the pot connecting bonding material **80** shown in FIGS. 10 and 11 for forming a decorative cover like the decorative covering **50d** shown in FIG. 11 if desired in a particular application.

The sheet of material **10e** includes a sheet extension **25e**. The sheet extension **25e** is constructed exactly like the sheet extension **25** shown in FIGS. 1 through 4 and described in detail before, except the sheet extension **25e** does not include a connecting bonding material, although it could include connecting bonding material if desired. Rather, the sheet extension **25e** includes reinforcing means. The reinforcing means more particularly comprises a reinforcing element **87**. The reinforcing element **87** is connected to the

sheet extension **25e** in a manner like that described before in connection with the reinforcing elements **88** and **90**.

The sheet extension **25e** is formed about the floral grouping in a manner like that described before in connection with the sheet extension **25** shown in FIGS. 1 through 4. The open upper end of the sheet extension **25** which extends above the upper end of the floral grouping is closed by bending and twisting the portion of the sheet extension **25e** having the reinforcing element **87** therein. The reinforcing element **87** cooperates to maintain the open upper end of the sheet extension **25e** closed over the floral grouping to provide the protective cover.

EMBODIMENT OF FIGS. 14 AND 15

Shown in FIGS. 14 and 15 is yet another modified sheet of material **10f** which is constructed exactly like the sheet of material **10** shown in FIGS. 1-4 and described in detail before, except the sheet of material **10f** does not necessarily include a connecting bonding material like the connecting bonding material **24** described in detail before with respect to the sheet of material **10**. The sheet of material **10f** more particularly includes reinforcing means **98**.

The reinforcing means **98** comprises a plurality of reinforcing elements **100**. (only one of the reinforcing elements **100** being designated with the reference numeral in FIGS. 14 and 15). The reinforcing elements **100** may be constructed of any material and any shape so long as the reinforcing elements **100** cooperate with the sheet of material **10f** to reinforce the sheet of material **10f** and assist in maintaining the formed shape of the sheet of material **10f**. In one form, the reinforcing elements **100** may comprise a plurality of wire elements or plastic rod like elements for example. The reinforcing elements **100** may be continuous as shown in FIGS. 14 and 15 or may be segmented as may be desired in a particular application. The reinforcing elements **100** extend over substantially the entire surface of the sheet of material **10f**.

The sheet of material **10f** is formed about the flower pot **30** in the manner described before in connection with FIG. 2 or 7, except, in this embodiment, the reinforcing elements **100** cooperate to maintain a portion of the sheet of material **10f** formed in the form of the crimped portion like the crimped portion **46** or **46b** in lieu of connecting bonding material.

The sheet of material **10f** may include connecting bonding material like the connecting bonding material **24** or connecting bonding material like the cohesive connecting bonding material **54** if desired in a particular application. Also, the sheet of material **10f** may include a drawstring like the drawstring **58** shown in FIG. 8 and described in detail before. Also, the sheet of material **10f** may include a pot connecting bonding material like the pot connecting bonding material **80** shown in FIGS. 10 and 11 and described in detail before.

The sheet of material **10f** includes the sheet extension **25f** connected thereto. The sheet extension **25f** includes reinforcing means **97**. In one form, the reinforcing means **97** comprises a plurality of reinforcing elements **101**. The reinforcing elements **101** may be continuous as shown in FIGS. 14 and 15 or may be segmented as may be desired in a particular application. The reinforcing elements **101** extend over substantially the entire surface of the sheet extension **25f**.

The sheet extension **25f** is formed about the floral grouping in a manner like that described before in connection with the sheet extension **25** shown in FIGS. 1 through 4. The open

upper end of the sheet extension **25f** then is closed over the upper end of the floral grouping to provide the protective covering. The reinforcing elements **101** cooperate to maintain the sheet extension **25f** closed over the open upper end of the floral grouping.

The reinforcing elements **101** preferably are not continuous or part of the reinforcing elements **100** so that the sheet extension **25f** may be separated from the sheet of material **10f** by tearing along the line of perforations **53f**. The sheet extension **25f** may include a drawstring like the drawstring **57** shown in FIG. 8 and described in detail before.

EMBODIMENT OF FIGS. 16 AND 17

Shown in FIGS. 16 and 17 is still another modified sheet of material **10g** which is constructed exactly like the sheet of material **10** shown in FIGS. 1-4 and described in detail before, except the sheet of material **10g** does not include connecting bonding material like the connecting bonding material **24** on the sheet of material **10** shown in FIGS. 1-4. Rather, the sheet of material **10g** includes a shrink material **102** disposed on the upper surface **20g** of the sheet of material **10g**. The shrink material **102** may be constructed of any material which shrinks when subjected to heat or liquid or some other outside force or fluid. Such materials are well known in the art.

The shrink material **102** extends circumferentially about the upper surface **20g** of the sheet of material **10g**. The shrink material **102** is spaced a distance **104** from the outer peripheral edge **26g** of the sheet of material **10g**.

The sheet of material **10g** is formed about the flower pot **30** in the manner exactly like that described before in connection with FIGS. 2 or 7. The shrink material **102** is positioned on the sheet of material **10g** and the sheet of material **10g** is sized and shaped so that the shrink material **102** is positioned above the upper end **32** of the flower pot **30** when the sheet of material **10g** is formed about the flower pot **30** in a manner like that described before with respect to the positioning of the connecting bonding material **24** on the sheet of material **10** (FIGS. 1-4). In this position, the shrink material **102** then is subjected to heat or any of the other means mentioned before causing the shrink material **102** to shrink thereby forming the crimped portion **46g** (FIG. 17). The crimped portion **46g** will operate in a manner exactly like that described before with respect to the crimped portion **46** on the decorative cover **50** (FIGS. 2 and 3).

The sheet of material **10g** has the sheet extension **25g** connected thereto. The sheet extension **25g** is constructed exactly like the sheet extension **25** shown in FIGS. 1 through 4 and described in detail before.

The sheet extension **25g** is formed about the floral grouping and a portion of the sheet extension **25g** near the outer peripheral edge **27g** is closed over the upper end of the floral grouping to a position wherein portions of the sheet extension **25g** are bondingly contacted by the bonding material **33g** to close the open upper end of the sheet extension **25g** over the upper end of the floral grouping to provide the protective covering. The bonding material **33g** may comprise shrink material.

EMBODIMENT OF FIG. 18

Shown in FIG. 18 is a plurality of sheets of material **10h** (only one of the sheets of material **10h** being designated with a reference numeral in FIG. 18 for example). The sheets of material **10h** are positioned and connected together to form a pad **106**. The sheets of material **10h** may be constructed in any of the forms of sheets of material described herein.

Each of the sheets of material **10h** includes the sheet extension **25h** (only one of the sheet extensions **25h** being designated with a reference numeral in FIG. 18 for example).

In this embodiment, one of the sheets of material **10h** in the pad **106** is removed from the pad **106** and formed about the flower pot **30** to provide the decorative covering in any of the manners described herein. In the alternative, the flower pot **30** may be placed on one of the sheets of material **10h** in the pad **106** and then formed about the flower pot **30** to provide the decorative cover in any of the manners described herein while simultaneously removing the sheet of material **10h** from the pad **106**. The sheet extensions **25h** are formed about the floral grouping to provide the protective covering in the manners described before.

EMBODIMENT OF FIG. 19

Shown in FIG. 19 is a roll of material **108** generally supported. In this embodiment, material from the roll of material **108** is unrolled and pulled from the roll of material **108** in a direction **110** to unroll a portion of the material from the roll of material **108**. When a predetermined amount of the material has been unrolled from the roll of material **108**, a knife edge **112** is brought into cutting contact with a portion of the material unrolled from the roll of material **108** to sever a sheet of material from the roll of material. The knife edge **112** may be automatically actuated by an actuator **114** which may be a hydraulic cylinder for example or the knife edge **112** may be a manually actuated knife edge or a knife edge on the edge of a container which contains the roll of material **108** for example.

In this embodiment, the material in the roll of material **108** is constructed of any of the materials described herein with respect to any of the sheets of materials with the sheet extension connected thereto described herein to provide any of the sheets of material with the sheet extension connected thereto described herein. In this embodiment, the sheets of materials with the sheet extension connected thereto described herein are supplied in the form of the roll of material **108** and the sheets of material with the sheet extension connected thereto are severed from the roll of material **108** in the manner just described.

EMBODIMENT OF FIG. 20

Shown in FIG. 20 is a roll of material **116** which is generally supported. The material in the roll of material may be constructed of any of the materials described herein with respect to any of the sheets of materials described herein. As shown in FIG. 20, the roll of material **116** contains a plurality of spaced apart bonding materials **24j** disposed on the material and the roll of material. The material in the roll of material also contains a plurality of spaced apart perforations **118** (only one of the perforations **118** being designated with a reference numeral in FIG. 20). The perforations **118** separate the material in the roll of material **116** into a plurality of sheets of material **10j**. Each of the sheets of material **10j** are constructed exactly like the sheet of material **10** shown in FIGS. 1-4 and described in detail before.

Each of the sheets of material **10j** has a sheet extension **25j** connected thereto.

In this embodiment, the material is unrolled from the roll of material **116** to a desired length. A portion of the material in the roll of material **116** then is separated from the roll of material **116** by tearing the material along one of the perforations **118** to provide the sheet of material **10j** with the sheet extension **25j**, connected thereto. The sheet of material

10j then is wrapped or formed about the flower pot **30** in any of the manners described herein.

It should be noted that the sheet of material **10j** has been described before as being constructed like the sheet of material **10** shown in FIGS. 1-4, although the sheet of material **10j** could be constructed like any of the other sheets of material described herein if desired in a particular application.

EMBODIMENT OF FIGS. 21, 22 AND 23

Shown in FIG. 23 is a sheet of material **10k** which is constructed exactly like the sheet of material **10** shown in FIG. 1 and described in detail before, except the sheet of material **10k** also includes a plurality of strips of pot connecting bonding material **120** with the individual strips of the pot connecting bonding material **120** being designated in FIG. 21 by the individual reference numerals **120a**, **120b**, **120c**, **120d** and **120e**.

The pot connecting bonding materials **120** are spaced a distance circumferentially apart about the sheet of material **10k**. Each of the pot connecting bonding materials **120** extends from the connecting bonding material **24** a distance radially inwardly toward a central portion of the sheet of material **10k**. The pot connecting bonding materials **120** preferably are pressure sensitive adhesive pot connecting bonding materials. The pot connecting bonding materials **120** also could be a cohesive, however, in this instance, a corresponding cohesive pot connecting bonding material also would be disposed on the flower pot **30** for reasons which will be made more apparent below.

The sheet of material **10k** is formed about the flower pot **30** (FIGS. 22 and 23) in a manner exactly like that described before in connection with the sheet of material **10** (FIGS. 1-4) except, in this instance, portions of the upper surface **20k** having the pot connecting bonding materials **120** disposed thereon are positioned adjacent a portion of the outer peripheral surface **36** of the flower pot **30** whereby the pot connecting bonding materials **120** bondingly engage and bondingly connect portions of the sheet of material **10k** to the outer peripheral surface **36** of the flower pot **30**. The pot connecting bonding materials **120** are positioned on the sheet of material **10k** and sized so that the pot connecting bonding materials **120** each extend generally between the upper end **32** and the lower end **30** of the flower pot **30** when the portions of the sheet of material **10k** having the pot connecting bonding materials **120** disposed thereon are positioned adjacent the outer peripheral surface **36** of the flower pot **30**.

Since the pot connecting bonding materials **120** are spaced a distance apart circumferentially about the sheet of material **10k**, portions of the sheet of material **10k** will be bondingly connected to the outer peripheral surface **42** of the flower pot **30** while other portions of the sheet of material **10k** will not be connected to the outer peripheral surface **42** of the flower pot **30** (FIGS. 22 and 23). More particularly, when the sheet of material **10k** is connected to the flower pot **30**, portions of the sheet of material **10k** will be connected to the outer peripheral surface **36** of the flower pot **30** at positions extending between the upper and the lower ends **32** and **34** of the flower pot **30** and extending a distance circumferentially about the flower pot **30** to form connected portions, while remaining portions of the sheet of material **10k** extending between the upper and the lower ends **32** and **34** of the flower pot **30** will not be connected to the flower pot **30** forming unconnected portions **124** (the specific or individual connected portions **122** being designated by the

reference numerals **122a**, **122b**, **122c**, **122d**, **122e** and **122f** in FIG. **23** and the specific or individual unconnected portions being designated in FIG. **23** by the specific reference numerals **124a**, **124b**, **124c**, **124d**, **124e** and **124f**). Each connected portion **122** extends a distance circumferentially about the flower pot **30** and extends generally between the upper and the lower ends **32** and **34** of the flower pot **30**. Each unconnected portion **124** extends between the upper and the lower ends **32** and **34** of the flower pot **30** and each unconnected portion **124** extends a distance circumferentially about the flower pot **30**. Each unconnected portion **124** is disposed generally between two adjacent connected portions **122**.

The sheet of material **10k** also could be constructed like the sheet of material **10a** (FIGS. **5** and **6**) or shaped to form an outwardly extending crimped portion like the crimped portion **46b** (FIG. **7**) or to include a drawstring like the drawstring **58** (FIGS. **8** and **9**) or to include reinforcing means like the reinforcing means **86** (FIG. **12**) or reinforcing means like the reinforcing means **98** (FIG. **14**) or shrink material like the shrink material **102** (FIG. **16**).

The sheet of material **10k** has the sheet extension **25k** connected thereto. The sheet extension **25k** is constructed exactly like the sheet extension **25** shown in FIGS. **1** through **4** and described in detail before.

In use, the sheet extension **25k** is formed about the floral grouping and the open upper end of the sheet extension **25k** is closed via the contact between the bonding material **33k** and adjacent portions of the sheet extension **25k** in a manner like that described before.

EMBODIMENT OF FIG. 24

Shown in FIG. **24** is a flower pot **30l** which is constructed exactly like the flower pot **30** described in detail before, except the flower pot **30l** includes pot connecting bonding materials **126** (only two pot connecting bonding materials **126** being shown in FIG. **24** and designated therein by the individual reference numerals **126a** and **126b**). The pot connecting bonding materials **126** are spaced apart circumferentially about the outer peripheral surface **36l** of the flower pot **30l** and each of the pot connecting bonding materials **126** extends between the upper and the lower ends **32l** and **34l** of the flower pot **30l**.

The flower pot **30l** may be used in connection with the sheet of material **10k** and the sheet extension **25k** shown in FIG. **21** where the pot connecting bonding materials **120** on the sheet of material **10k** are cohesive pot connecting bonding materials and the pot connecting bonding materials **126** on the flower pot **30l** are cohesive pot connecting bonding materials. In this embodiment, the cohesive pot connecting bonding materials **120** on the sheet of material **10k** cohesively bondingly engage and bondingly connect to the pot connecting bonding materials **126** on the flower pot **30l** to form a decorative cover like that described before in connection with the decorative cover **50k** (FIGS. **22** and **23**).

The pot connecting bonding materials **126** also may be adhesive pot connecting bonding materials **126**. In this instance, the flower pot **30l** may be used in connection with a sheet of material like the sheet of material **10** shown in FIGS. **1-4** and described in detail before. In this embodiment, the sheet of material **10** (FIGS. **1-4**) is formed about the flower pot **30l** in the manner like that described before in connection with the sheet of material **10k** (FIGS. **21-23**) and the adhesive pot connecting bonding materials **126** bondingly engage and bondingly connect to portions of the sheet of material **10** (FIGS. **1-4**) to form a decorative cover **50k** (FIGS. **22** and **23**).

The flower pot **30l** also may be used in connection with any of the other sheets of material and sheet extensions described herein.

EMBODIMENT OF FIG. 25

Shown in FIG. **25** is a sheet of material **10m** which is constructed exactly like the sheet of material **10d** (FIG. **10**), except the sheet of material **10m** does not necessarily include the connecting bonding material like the connecting bonding material **24d** shown in FIG. **10** in connection with the sheet of material **10d**. In this embodiment, the sheet of material **10m** is formed about the flower pot **30** in the manner exactly like that described before in connection with the sheet of material **10d** (FIGS. **10** and **11**), except a pot connecting bonding material **80m** is positioned on the sheet of material **10m** so that a portion of the sheet of material **10m** near the upper end **32** of the flower pot **30** is folded over and disposed adjacent a portion of the inner peripheral surface **42** of the flower pot **30** near the upper end of the flower pot **32**. In this position, the pot connecting bonding material **80m** is bondingly engaged with and bondingly connected to a portion of the inner peripheral surface **42** of the flower pot **30** near the upper end **32** thereof. The bonding engagement between the pot connecting bonding material **80m** and the inner peripheral surface **42** of the flower pot **30** extends circumferentially about the flower pot **30**.

The sheet of material **10m** may be constructed like any of the other sheets of material described herein, except the pot bonding material **80m** is positioned on the sheet of material **10m** to bondingly engage and connect with a portion of the inner peripheral surface **42** of the flower pot **30**.

The sheet of material **10m** has the sheet extension **25m** connected thereto. The sheet extension **25m** may be constructed exactly like the sheet extension **25** shown in FIGS. **1** through **4** and described in detail before.

EMBODIMENT OF FIG. 26

Shown in FIG. **26** is a modified flower pot **30n** which is constructed exactly like the flower pots **30** described herein, except the flower pot **30n** includes a pot connecting bonding material **128** disposed on a portion of the inner peripheral surface **42n** of the flower pot **30n** near and adjacent the upper end **32n** of the flower pot **30n**. The pot connecting bonding material **128** extends circumferentially about the inner peripheral surface **42n** of the flower pot **30n**.

The flower pot **30n** may be used in connection with a sheet of material and sheet extension constructed exactly like the sheet of material **10** and sheet extension **25** shown in FIGS. **1-4** and described in detail before, except the sheet of material **10** does not necessarily include the connecting bonding material like the connecting bonding material **24**. In this embodiment, the sheet of material is formed about the flower pot **30n** in a manner like that described before in connection with the sheet of material **10** (FIGS. **1-4**), except a portion of the sheet of material **10** is folded over and adjacent a portion of the inner peripheral surface **42n** of the flower pot **30n** into bonding engagement with the pot connecting bonding material **128** for bondingly connecting the sheet of material to the flower pot **30n** in a manner like that described before in connection with the sheet of material **10m** (FIG. **25**).

The pot connecting bonding material **128** as just described preferably is an adhesive pot connecting bonding material. The pot connecting bonding material **128** may be a cohesive pot connecting bonding material and, in this instance, the flower pot **30n** would be used in connection with a sheet of

material and sheet extension like the sheet of material **10m** and sheet extension **25m** (FIG. 25) except the pot connecting bonding material **80m** would be a cohesive pot connecting bonding material **80m** cohesively engaging and cohesively bonding with the cohesive pot connecting bonding material **128** on the flower pot **30n**.

The flower pot **30n** also may be used in connection with any of the other sheets of material or sheet extensions described herein, except portions of the sheet of materials would be bondingly connected to the flower pot by way of the pot connecting bonding material **128** and, in this instance, it is not necessary to form the crimped portion, although the crimped portion also could be formed if desired in any particular application.

EMBODIMENT OF FIGS. 27, 28 AND 29

Shown in FIGS. 27, 28 and 29 is another modified sheet of material **10p** which is constructed exactly like the sheet of material **10** shown in FIGS. 1-4 and described in detail before, except the sheet of material **10p** does not necessarily include the connecting bonding material like the connecting bonding material **24**. Rather, the sheet of material **10p** includes a drawstring in the form of a ribbon **132** having opposite ends **134** and **136** connected to a portion of the upper surface **20p** of the sheet of material **10p**. More particularly, a portion of the ribbon **132** between the opposite ends **134** and **136** is connected to the upper surface **20p** of the sheet of material **10p** while portions of the ribbon **132** near each of the ends **134** and **136** are unconnected from the sheet of material **10p**. The portions of the ribbon **132** near the opposite ends **134** and **136** which are unconnected to the sheet of material **10p** each extend a distance from the sheet of material **10p**. The ribbon **132** may be connected to the sheet of material **10p** in any suitable manner. As shown in FIG. 28, the ribbon **132** is connected to the sheet of material **10p** by way of an adhesive connecting bonding material **138**. The ribbon **132** may be connected between two sheets like described before in connection with the drawstring **58** shown in FIGS. 8 and 9.

The portion of the ribbon **132** connected to the sheet of material **10p** extends a distance circumferentially about the sheet of material **10p**. The portion of the ribbon **132** connected to the sheet of material **10p** is spaced a distance **140** from the outer peripheral surface **26p** of the sheet of material **10p**.

The sheet of material **10p** is formed about the flower pot with a portion of the sheet of material **10p** extending above the upper end **32** of the flower pot **30**. More particularly, the ribbon **132** is positioned on the sheet of material **10p** so that, when the sheet of material **10p** is formed about the flower pot **30**, the ribbon **132** extends above the upper end **32** of the flower pot **30**. In this position, the opposite ends of the ribbon **132** are cinched or drawn tight to gather the portions of the sheet of material **10p** near and adjacent the ribbon **132** over the upper end **32** of the flower pot **30** to form a crimped portion like the crimped portions **46** described before. In this position, the ends **134** and **136** of the ribbon **132** are tied or otherwise secured to secure the ribbon **132** in the drawn or pulled position. Then, a bow **142** may be secured to the decorative cover **50p** (FIG. 29) by adhesively connecting the bow **142** to either a portion of the ribbon **132** or a portion of the outer peripheral surface of the decorative cover **50p**.

The sheet of material **10p** also may be constructed like any of the other sheets of materials described herein to bond two portions of the flower pot or to include connecting bonding materials for bondingly connecting adjacent por-

tions of the sheet of material when the ribbon **132** is drawn tightly about the upper end of the flower pot for example.

The sheet of material **10p** has a sheet extension **25p** connected thereto. The sheet extension **25p** has a ribbon **150** connected thereto by way of an adhesive bonding material **151** (FIG. 28). The ribbon **150** may be connected between two sheets like that described before in connection with the drawstring **57** shown in FIGS. 8 and 9. The portion of the ribbon **150** connected to the sheet extension **25p** extends circumferentially about the sheet extension **25p**. The portion of the ribbon **150** connected to the sheet extension **25p** is spaced a distance from the outer peripheral edge **27p** (FIG. 27).

The sheet extension **25p** is formed about the floral grouping **47** (FIG. 29). The ribbon **150** is drawn or pulled and then tied into a bow **153** (FIG. 29) for closing the open upper end of the sheet extension **25p** and securing the sheet extension **25p** about the floral grouping **47** to form the protective covering.

EMBODIMENT OF FIG. 30

Shown in FIG. 30 is the flower pot **30** having the growing medium **45** disposed therein. The floral grouping **47** extends a distance above the upper end **32** of the flower pot **30** in the manner described before. In this embodiment, the sheet of material **10r** is formed about the outer peripheral surface of the flower pot **30** and positioned so that a portion of the sheet of material **10r** near the outer peripheral edge **26r** extends a distance above the upper end **32** of the flower pot **30**. A circularly shaped band **160** is disposed about the portion of the sheet of material **10r** extending above the upper end **32** of the flower pot **30**. The band **160** crimps a portion of the sheet of material and pulls a portion of the sheet of material inwardly above the upper end **32** of the flower pot **30** for securing the sheet of material **10r** in the position extending about the outer peripheral surface **36** of the flower pot **30** to form the decorative cover.

The sheet extension **25r** is connected to the sheet of material **10r**. The sheet extension **25r** is constructed exactly like the sheet extension **25** shown in FIGS. 1 through 4 and described in detail before or any of the other sheet extensions described herein. The sheet extension **25r** is formed about the floral grouping **47** and a portion of the sheet extension **25r** near the outer peripheral edge **27r** is closed via the bonding material in a manner like that described before in connection with the sheet extension **25** shown in FIGS. 1 through 4.

It should be noted that the band **160** may be disposed about the sheet of material **10r** and about the outer peripheral surface **36** of the flower pot **30** for securing the sheet of material **10r** in the position extending about the outer peripheral surface **36** of the flower pot **30** to provide the decorative covering if desired in a particular application.

As described herein, the various sheets of material are formed about the flower pot by hand forming the sheets of material about the flower pot and by hand crimping the material to form the crimped portions. It is contemplated that the forming of the sheet of material about the flower pot and the crimping of the sheet of material may be accomplished automatically or semi-automatically by way of a machine. For example, a machine may include pivoting elements or fingers which are automatically pivoted to move the sheet of material about the flower pot and position a sheet of material as described herein. In this instance, the fingers may include a separate element for forming the crimped portion or the element for forming the crimped portion may be a separate

device such as halves of a donut shaped device which are moved inwardly to form the crimped portion after the sheet of material has been formed about the flower pot. In lieu of fingers or elements, the sheet of material may be blown by way of air jets or the like around the flower pot and then a crimping device may be disposed adjacent portions of the sheet of material to form the crimped portions. In a like manner, the sheet extension may be formed about the floral grouping in an automatic or semi-automatic manner.

It also is contemplated that the crimped portion may be formed by a strivet or band which is automatically applied to the sheet of material after the sheet of material has been formed about the flower pot with the strivet or band being positioned above the upper end of the flower pot.

EMBODIMENT OF FIGS. 32 AND 33

Shown in FIGS. 31 and 33 and designated therein by the general reference numeral 210 is a flower pot cover constructed in accordance with the present invention. The flower pot cover 210 comprises a base 212 and a skirt 214. A sheet extension 25s is connected to the base 212 or, more particularly, to the outer periphery 232 of the skirt 214. The sheet extension 25s is constructed exactly like the sheet extension 25 shown in FIGS. 1 through 4 and described in detail before.

In one preferred form, the flower pot cover 210 is formed by taking a sheet of material constructed like the other sheets of material 10 described and placing it between a male and a female mold. In this embodiment, the male mold is brought into mating engagement with the female mold thereby forming the flower pot cover 210. In this process, a plurality of overlapping folds 216 (FIGS. 31 and 32) are formed in the base 212. The overlapping folds 216 cooperate to maintain the structural integrity of the base 212 and cooperate to maintain the base 212 in the preformed shape. Apparatus and methods for forming a flower pot cover as just described are disclosed in detail in U.S. Pat. No. 4,773,182, titled "ARTICLE FORMING SYSTEM" issued Sep. 27, 1988 and assigned to the Assignee of the present invention and the disclosure of this patent hereby specifically is incorporated herein by reference.

The base 212 has an upper end 218, a lower end 220 and an outer peripheral surface 222 (FIGS. 31-32). A pot opening 224 (FIGS. 31 and 33) is formed through the upper end 218 of the base 212 providing access to a pot receiving space 226 (FIGS. 31 and 33). The pot receiving space 226 forms an inner peripheral surface 228 in the base 212. As shown in FIGS. 31 and 32, the base 212 is generally cylindrically shaped, although the base 212 could be any geometric shape as may be desired in a particular application.

In a preferred manner, the skirt 214 is formed integrally with the base 212. The skirt 214 is connected to the upper end 218 of the base 212 at a connection 230 (FIGS. 32 and 33) between the upper end 218 of the base 212 and the skirt 214. The skirt 214 extends a distance radially outwardly from the base 212 terminating with an outer periphery 232. The skirt 214 has an inner peripheral face 234 (FIGS. 31 and 33) and an outer peripheral surface 236 (FIGS. 32 and 33). In one form, shown in FIGS. 31 and 32, a plurality of folds 238 also are formed in the skirt 214 with most of the folds 238 extending radially outwardly from the upper end 218 of the base 212 toward the outer periphery 232 of the skirt 214.

The base 212 and the skirt 214 may be constructed of any suitable material that is capable of being formed into the flower pot cover 210. As mentioned before, the base 212 and the skirt 214 are constructed from a sheet of material and the

sheet of material is constructed from any of the materials described before it connection with the sheet of material 10 for example.

A bonding material 240 (FIG. 31) is disposed on a portion of the inner peripheral surface 234 of the skirt 214. The bonding material 240 more particularly is disposed near the connection 230 between the skirt 214 and the upper end 218 of the base 212 (FIG. 31). The bonding material 240 covers an area extending from the connection 230 of the skirt 214 to the upper end 218 of the base 212 a distance radially outwardly to a line 242 (FIG. 31) spaced a distance radially outwardly from the connection 230. Although the bonding material 240 is shown in FIGS. 31 and 32 in the form of a continuous strip of the bonding material 240, the bonding material 240 may be in the form of spots or spaced apart strips or any other form desired in a particular application suitable for effecting the crimping described below.

As mentioned before, the bonding material 240 preferably is an adhesive or cohesive. More particularly, the bonding material 240 preferably is a cohesive. When the bonding material 240 is a cohesive, a plurality of the flower pot covers 210 may be stacked one on top of the other with the base 212 of an adjacent flower pot cover being disposed in the pot receiving space 226 of an adjacent flower pot cover 210. When the bonding material 240 is a cohesive, the bonding material 240 will not cause one flower pot cover 210 to be bonded to an adjacent flower pot cover 210 when the flower pot covers 210 are stacked in the manner just described.

The bonding material 240 may be applied to the sheet of material prior to forming the sheet of material into the flower pot cover 210 or the bonding material 240 may be applied during the forming of the sheet of material into the flower pot cover 210 or the bonding material 240 may be applied after the flower pot cover 210 has been formed.

As mentioned before, the flower pot cover 210 is adapted and configured to be used with a flower pot, a flower pot being shown in FIG. 33 and designated therein by the referenced numeral 244. As shown in FIG. 33, the flower pot 244 has an upper end 246, a lower end 248, an outer peripheral surface 250 with an opening 252 being formed through the upper end 246 of the flower pot 244 providing access to a plant or flower receiving space 254.

In use, the lower end 248 of the flower pot 244 is disposed through the pot opening 224 and into the pot receiving space 226 of the flower pot cover 210 to a position wherein the lower end 248 of the flower pot 244 is disposed near the lower end 220 of the flower pot cover 210 and the upper end 246 of the flower pot 244 is disposed near the upper end 218 of the flower pot cover 210.

After the flower pot 244 has been disposed in the pot receiving space 226, a crimped portion 256 (FIG. 33) is formed in the skirt 214 by bringing together adjacent portions of the skirt 214 about the bonding material 240 thereby causing the adjacent portions to be bonded together for forming the crimped portion 256. The crimping of the skirt 214 may be accomplished by hand or with a device or machine as may be desired in a particular application.

The crimped portion 256 extends a distance radially inwardly above the upper end 246 of the flower pot 244. The crimped portion 256 is disposed about adjacent the upper end 246 of the flower pot 244 and the crimped portion 256 engages a portion of the upper end 246 of the flower pot 244 for cooperating to maintain the flower pot cover 210 assembled around or connected to the flower pot 244.

The crimped portion 256 preferably extends circumferentially about the upper end 218 of the flower pot cover 210

and preferably circumferentially around the upper end 246 of the flower pot 244. In some applications, it may be desirable to form the crimped portion 256 only at certain positions spaced circumferentially about the upper end 218 of the base 212.

The flower pot cover 210 substantially encompasses the flower pot 244 when the flower pot 244 is disposed in the pot receiving space 226.

The sheet extension 25s is formed about the floral grouping 47 (FIG. 33). The sheet extension 25s is constructed exactly like the sheet extension 25 shown in FIGS. 1 through 4 and described in detail before. The open upper end of the sheet extension 25s is closed by contacting the bonding material 33s with adjacent portions of the sheet extension 25s in the manner described before. The sheet extension 25s substantially encompasses the floral grouping 47 and provides the protective covering in the manner described before.

EMBODIMENT OF FIGS. 34 AND 35

Shown in FIGS. 34 and 35 is a modified flower pot cover 210a which is constructed exactly like the flower pot cover 210 shown in FIGS. 31, 32 and 33 and described in detail before, except the flower pot cover 210a also includes a bonding material 258 disposed on the inner peripheral surface 228a of the base 212a near the upper end 218a of the base 212a in addition to the bonding material 240a disposed on the inner peripheral surface 234a of the skirt 214a.

The bonding material 258 extends from the upper end 218a of the base 212a a distance toward the lower end 220a of the base 212a to a line 260 disposed near and spaced a distance from the upper end 218a of the base 212a (FIG. 34). The bonding material 258 extends circumferentially about the upper end 218a of the base 212a (FIG. 34). The bonding material 258 substantially covers the entire area between the upper end 218a of the base 212a and the line 260. It should be noted that the bonding material 258, although shown as a continuous strip in FIG. 34, could be spots or spaced apart strips if desired in a particular application.

In operation, as illustrated in FIG. 35, the flower pot cover 210a is disposed about the flower pot 244 in the manner described before in connection with the flower pot 210 shown in FIGS. 31, 32 and 33, and the crimped portion 256a is formed in the flower pot cover 210a in a manner exactly like that described before in connection with the flower pot cover 210 and the crimped portion 256 shown in FIG. 33. In addition, the bonding material 258 on the inner peripheral surface 228a of the base 212a bondingly engages to a portion of the outer peripheral surface 250 of the flower pot 244 near the upper end 246 of the flower pot 244. The bonding engagement between the bonding material 258 and the flower pot 244 further cooperates to secure the flower pot cover 210a to the flower pot 244.

In those instances where the bonding material 258 is a cohesive, a cohesive material also is included on the outer peripheral surface 250 of the flower pot 244 for bondingly engaging with the bonding material 258 on the flower pot cover 210a.

A sheet extension 25t is connected to the flower pot cover 210a. The sheet extension 25t is constructed exactly like the sheet extension 25s shown in FIGS. 31 through 33 and described in detail before. The sheet extension 25t is formed about the floral grouping to provide the protective covering in the manner described before.

EMBODIMENT OF FIG. 36 and FIG. 37

Shown in FIG. 36 is another modified flower pot cover 210b which is constructed exactly like the flower pot cover

210 shown in FIGS. 31 and 32, except the flower pot cover 210b does not include bonding material on the skirt 214b like the bonding material 240 on the skirt 214 shown in FIGS. 31 and 32. Rather, the flower pot cover 210b includes bonding material 262 disposed on the inner peripheral surface 228b of the flower pot cover 210b near the upper end 218b of the base 212. The bonding material 262 extends circumferentially about the upper end 218b of the base 212b. The bonding material 262 extends from the upper end 218b to a line 264 spaced a distance from the upper end 218b of the base 212b. The bonding material 262 substantially covers the entire area between the upper end 218b and the lines 264. The bonding material 262 could be in the form of spots or spaced apart strips if desired in a particular application.

In use, the flower pot 244 is disposed in the pot receiving space 226b of the flower pot cover 210b, as shown in FIG. 37. The crimped portion 256b is formed in the flower pot cover 210b by crimping together portions of the flower pot cover 210b near the bonding material 262 with the bonding material 262 cooperating to bond the overlapping crimped portions for maintaining the shape of the crimped portion 256b in a manner like that described before. In this application, the crimped portion 256b is formed in the base 212b, rather than in the skirt 214b as is the case in connection with the flower pot cover 210 shown in FIGS. 31, 32 and 33.

The flower pot cover 210b includes the sheet extension 25u. The sheet extension 25u is constructed exactly like the sheet extension 25s shown in FIGS. 31 through 33 and described in detail before. The sheet extension 25u is formed about the floral grouping in the manner described before to provide the protective covering.

EMBODIMENT OF FIG. 38

Shown in FIG. 38 is another modified flower pot cover 210c which is constructed exactly like the flower pot cover 210 shown in FIGS. 31 and 32 and described in detail before, except the flower pot cover 210c does not include the bonding material 240 on the base 212. Rather, the flower pot cover 210c includes bonding material 266 on the outer peripheral surface 236c of the skirt 214c. The bonding material 266 extends circumferentially around the connection 230c of the skirt 214c to the upper end 218c of the base 212c. The bonding material 266 extends from the connection 230c to a line 268 spaced a distance from the upper end 218c of the base 212c toward the upper periphery 232c of the skirt 214c.

In use, the flower pot cover 210c is disposed about a flower pot 244 and the crimped portion is formed by crimping together portions of the flower pot cover near and adjacent the bonding material 266 to form the crimped portion in a manner like that described before in connection with the flower pot cover 210 shown in FIG. 31, except the bonding material 240 is on the inner peripheral surface 234 of the base skirt 214, rather than the outer peripheral surface 236c as is the case with the flower pot cover 210c shown in FIG. 37.

The flower pot cover 10c includes the sheet extension 25w. The sheet extension 25w is constructed exactly like the sheet extension 25s shown in FIGS. 1 through 3 and described in detail before. The sheet extension 25w is formed about the floral grouping to provide the protective covering in the manner described before and has bonding material 33w for closing the sheet extension 25w.

EMBODIMENT OF FIG. 39

Shown in FIG. 39 is a flower pot cover 210d which is constructed exactly like the flower pot cover 210c shown in

FIG. 38 described in detail before, except the flower pot cover 210d also includes bonding material 270 on the outer peripheral surface of the base 212d near the connection 230d. In this instance, the crimped portion is formed by crimping together portions of the base 212d and the skirt 214d having the bonding materials 270 and 266 respectively thereon.

The flower pot cover 210d includes the sheet extension 25x. The sheet extension 25x is constructed exactly like the sheet extension 25s shown in FIGS. 31 through 33 and described in detail before. The sheet extension 25x is formed about the floral grouping to provide the protective covering in the manner described before and has a bonding material 33x for closing the sheet extension 25x.

EMBODIMENT OF FIG. 40

Shown in FIG. 40 is another modified flower pot cover 210a which is constructed exactly like the flower pot cover 210e, except the flower pot cover 210e does not include the bonding material 266 on the skirt. Rather, the flower pot cover 210e includes only a bonding material 274 on the base 212e which extends to a line 276. The flower pot cover 210e will operate to form the crimped portion in a manner exactly like that described before with respect to the flower pot covers 210c and 210d shown in FIGS. 38 and 39, except the crimped portion only will be formed by crimping together portions of the bonding material 274 on the base 212e.

The flower pot cover 210e includes the sheet extension 25y. The sheet extension 25y is constructed exactly like the sheet extension 25s shown in FIGS. 31 through 33 and described in detail before. The sheet extension 25y is formed about the floral grouping to provide the protective covering in the manner described before and has a bonding material 33y for closing the sheet extension 25y.

The sheet extensions 25s, 25t, 25u, 25w, 25x and 25y may be constructed like any of the other sheet extensions described herein as may be desired in a particular application.

Changes may be made in the construction and the operation of the various components, elements and assemblies described herein and changes may be made in the steps or the sequence of steps of the methods described herein without departing from the spirit and scope of the invention as defined in the following claims.

What is claimed is:

1. A method for providing a decorative covering and a protective covering comprising:

providing a base having an upper end, a lower end, an outer peripheral surface and a pot opening formed through the upper end of the base providing access to a pot receiving space, the pot receiving space forming an inner peripheral surface in the base, a bonding material being disposed on the base, a sheet extension extending a distance from the upper end of the base;

providing a flower pot having an upper end, a lower end and an outer peripheral surface with a floral grouping being disposed in the flower pot;

disposing the flower pot in the pot receiving space of the base;

forming a crimped portion in the base by crimping together portions of the base with the bonding material thereon thereby providing the decorative cover; and

forming the sheet extension about the floral grouping to provide the protective covering.

2. The method of claim 1 wherein the step of forming the crimped portion is defined further as forming the crimped portion extending circumferentially about the base.

3. The method of claim 1 wherein the step of providing the base is defined further as providing the base with the bonding material disposed on the inner peripheral surface thereof.

4. The method of claim 1 wherein the step of providing the base is defined further as providing the base with the bonding material disposed on the outer peripheral surface thereof.

5. The method of claim 1 wherein the step of providing the base is defined further as providing the base having a skirt extending the distance from the upper end of the base.

6. The method of claim 5 wherein the bonding material disposed on the base is an adhesive or cohesive bonding material.

7. The method of claim 5 wherein the step of providing the base is defined further as providing the base with the bonding material disposed on the inner peripheral surface thereof.

8. The method of claim 5 wherein the step of providing the base is defined further as providing the base with the bonding material disposed on the outer peripheral surface thereof.

9. A method for providing a decorative covering and a protective covering comprising:

providing a base having an upper end, a lower end, an outer peripheral surface and a pot opening formed through the upper end of the base providing access to a pot receiving space, the pot receiving space forming an inner peripheral surface in the base, an adhesive or cohesive bonding material being disposed on the base, a sheet extension extending a distance from the upper end of the base;

providing a flower pot having an upper end, a lower end and an outer peripheral surface with a floral grouping being disposed in the flower pot;

disposing the flower pot in the pot receiving space of the base;

forming a crimped portion in the base by crimping together portions of the base with the adhesive or cohesive bonding material thereon thereby providing the decorative cover; and

forming the sheet extension about the floral grouping to provide the protective covering.

10. A method for providing a decorative covering and a protective covering comprising:

providing a base having an upper end, a lower end, an outer peripheral surface and a pot opening formed through the upper end of the base providing access to a pot receiving space, the pot receiving space forming an inner peripheral surface in the base, and a skirt extending a distance outwardly from the upper end of the base terminating with an outer edge, the skirt having an outer peripheral surface and an inner peripheral surface, an adhesive or cohesive bonding material being disposed on a portion of the base or of the skirt, and a sheet extension extending a distance from the outer edge of the skirt;

providing a flower pot having an upper end, a lower end and an outer peripheral surface with a floral grouping being disposed in the flower pot;

disposing the flower pot in the pot receiving space of the base;

forming a crimped portion in that portion of the base or skirt having the bonding material by crimping together portions of the base or skirt with the adhesive or cohesive bonding material thereon thereby providing the decorative cover; and

27

forming the sheet extension about the floral grouping to provide the protective covering.

11. The method of claim **10** wherein in the step of providing the base, the bonding material is disposed on the inner peripheral surface of the base or of the skirt thereof.

28

12. The method of claim **10** wherein in the step of providing the base the bonding material is disposed on the outer peripheral surface of the base or of the skirt thereof.

* * * * *

UNITED STATES PATENT AND TRADEMARK OFFICE
CERTIFICATE OF CORRECTION

PATENT NO. : 5,974,651
DATED : November 2, 1999
INVENTOR(S) : Donald E. Weder

Page 1 of 2

It is certified that error appears in the above-identified patent and that said Letters Patent is hereby corrected as shown below:

Column 4,

Line 34, delete the word "has".

Column 5,

Line 56, place a -- , -- between the words, flower plant.

Column 9,

Line 29, delete the numeral "26" and substitute therefore the numeral -- 26c --.

Column 10,

Line 6, delete the word "opening" and substitute therefore the word -- openings --.

Column 15,

Line 26, delete the word "severe" and substitute therefore the word -- sever --.

Column 16,

Line 45, delete "30" first occurrence and substitute therefore the numeral -- 34 --.

Column 17,

Line 15, delete the numeral "55" and substitute the numeral -- 5 --.

Column 19,

Line 21, delete "lop" and substitute therefore the numeral -- 10p --.

Column 21,

Line 16, delete "FIGS. 32 and 33" and substitute therefore -- FIGS. 31, 32 and 33 --.
Lines 54 and 55, delete "FIGS 32 and 33" and substitute therefore -- FIGS, 31 and 32 --.

Column 22,

Line 2, delete the word "it" and substitute therefore the word -- in --.

Column 23,

Line 66, delete the numeral "36" and substitute therefore the numerals -- 36 and 37 --.

Column 24,

Line 7, delete the numeral "212" and substitute therefore the numeral -- 212b --.

UNITED STATES PATENT AND TRADEMARK OFFICE
CERTIFICATE OF CORRECTION

PATENT NO. : 5,974,651
DATED : November 2, 1999
INVENTOR(S) : Donald E. Weder

Page 2 of 2

It is certified that error appears in the above-identified patent and that said Letters Patent is hereby corrected as shown below:

Column 25,

Line 17, delete the numeral "210a" and substitute therefore the numeral -- 210e --.
Line 18, delete the numeral "210e" and substitute therefore the numeral -- 210d --.

Signed and Sealed this

Ninth Day of April, 2002

Attest:



Attesting Officer

JAMES E. ROGAN
Director of the United States Patent and Trademark Office