



US005971202A

United States Patent [19]
Filbrun

[11] **Patent Number:** **5,971,202**
[45] **Date of Patent:** **Oct. 26, 1999**

[54] **ICE CUBE RESTRAINING DEVICE**

[76] Inventor: **Roland Filbrun**, 8201 St. Route 55,
Springfield, Ohio 45502

[21] Appl. No.: **09/139,486**

[22] Filed: **Aug. 25, 1998**

[51] **Int. Cl.**⁶ **B65D 25/02**

[52] **U.S. Cl.** **220/719**

[58] **Field of Search** 220/719, 716,
220/713

2,690,064	9/1954	Rupe	65/13
2,753,050	7/1956	Langston	210/163
2,761,301	9/1956	Tellier	220/719
3,040,897	6/1962	Holman	210/244
3,360,161	12/1967	Smith	220/719
3,549,044	12/1970	Lerner	220/90.4
3,752,320	8/1973	Biro	210/469
4,184,603	1/1980	Hamilton, Sr.	220/254
4,842,157	6/1989	Stone-Parker et al.	220/90.4
4,938,375	7/1990	Fantacone	220/90.4
4,938,377	7/1990	Jarvis	220/719
5,370,258	12/1994	Fair	220/719

Primary Examiner—Stephen Castellano
Attorney, Agent, or Firm—Biebel & French

[56] **References Cited**

U.S. PATENT DOCUMENTS

D. 173,121	9/1954	Lynn	D44/1
D. 190,512	6/1961	Ayala	D44/29
D. 315,478	3/1991	Liggins	D7/667
D. 315,479	3/1991	Liggins	D7/667
D. 345,889	4/1994	Herricks	D7/396.2
D. 353,298	12/1994	Hartpence, Jr., et al.	D7/400
586,833	7/1897	Brown .	
1,173,374	2/1916	Nolda .	
1,174,518	3/1916	Nolda .	
1,254,251	1/1918	Magnus	220/719
1,847,879	3/1932	Knecht .	
2,136,755	11/1938	Prince	65/13
2,555,766	6/1951	Siczkiwicz, Jr.	210/162
2,601,767	7/1952	Wall	220/719

[57] **ABSTRACT**

An ice cube restraining device for restraining ice cubes in the bottom of a drink container. The device includes a plurality of contact patches for engaging the interior surface of the drink container, and flexible circumferential web pieces which extend between adjacent pairs of the contact patches to support the contact patches in a circumferential direction. The device further includes a central hoop member and a plurality of flexible web pieces which extend radially inwardly from the contact patches to the central hoop member to thereby support the contact patches in a radial direction.

15 Claims, 4 Drawing Sheets

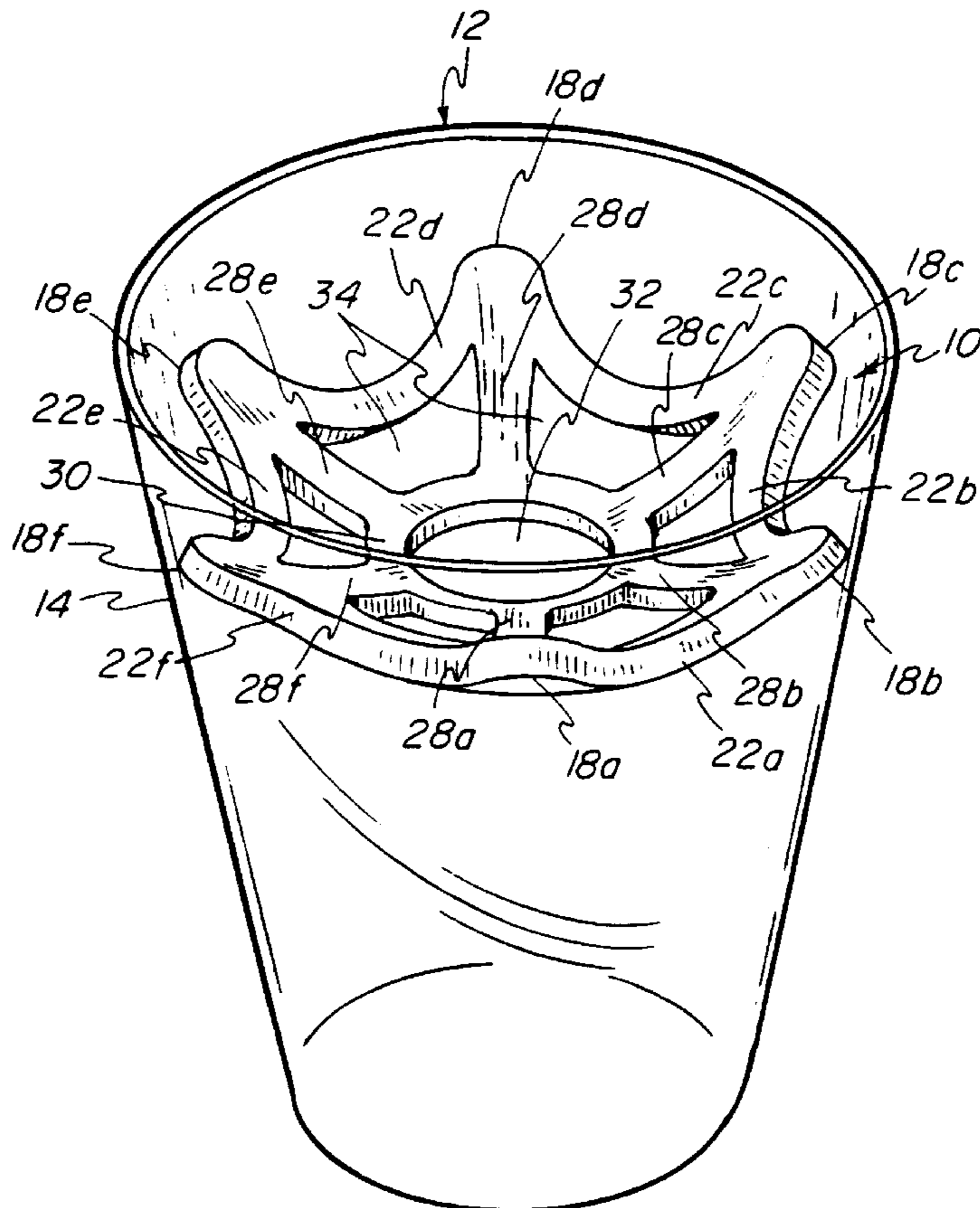

FIG -1

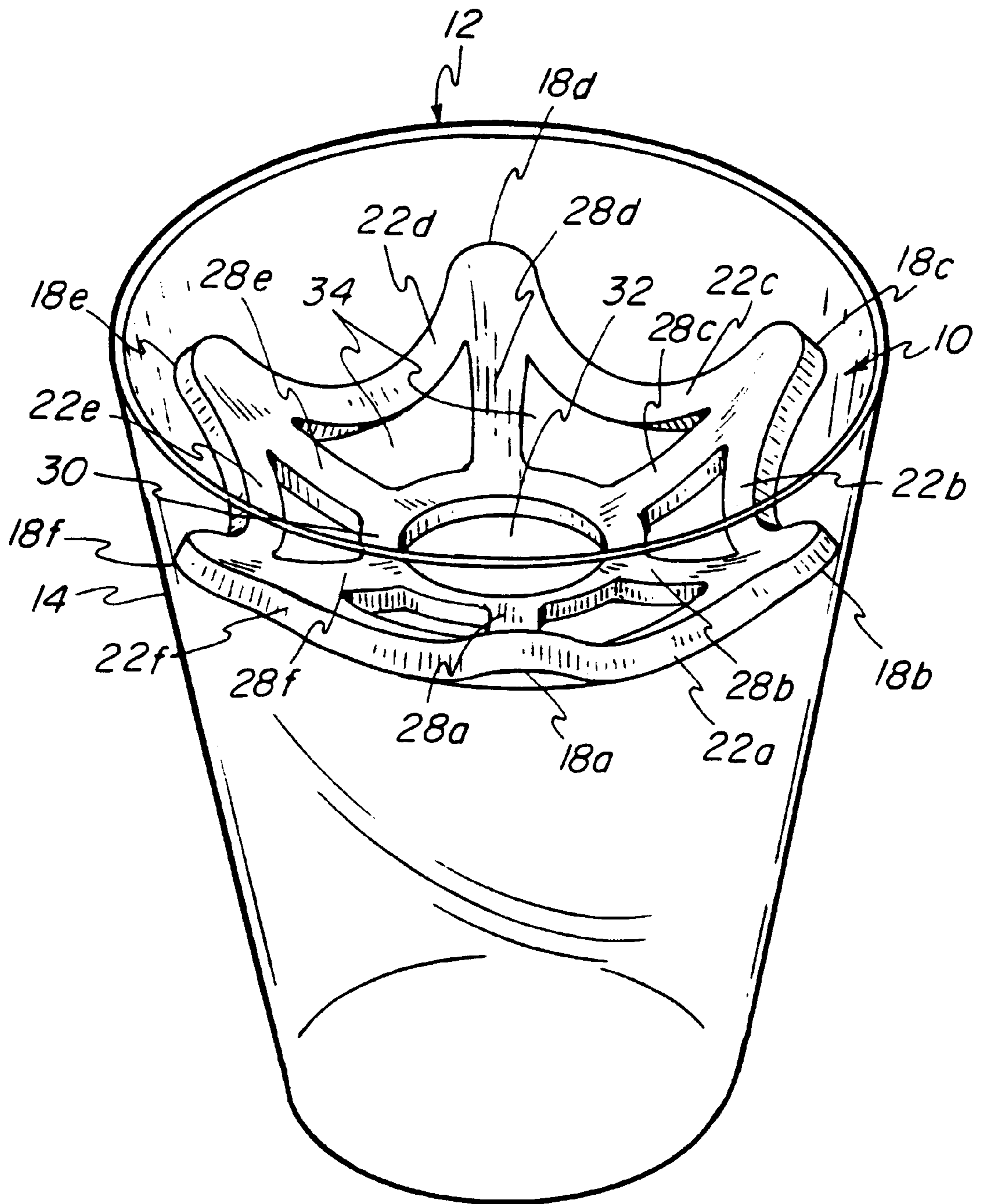

FIG - 2

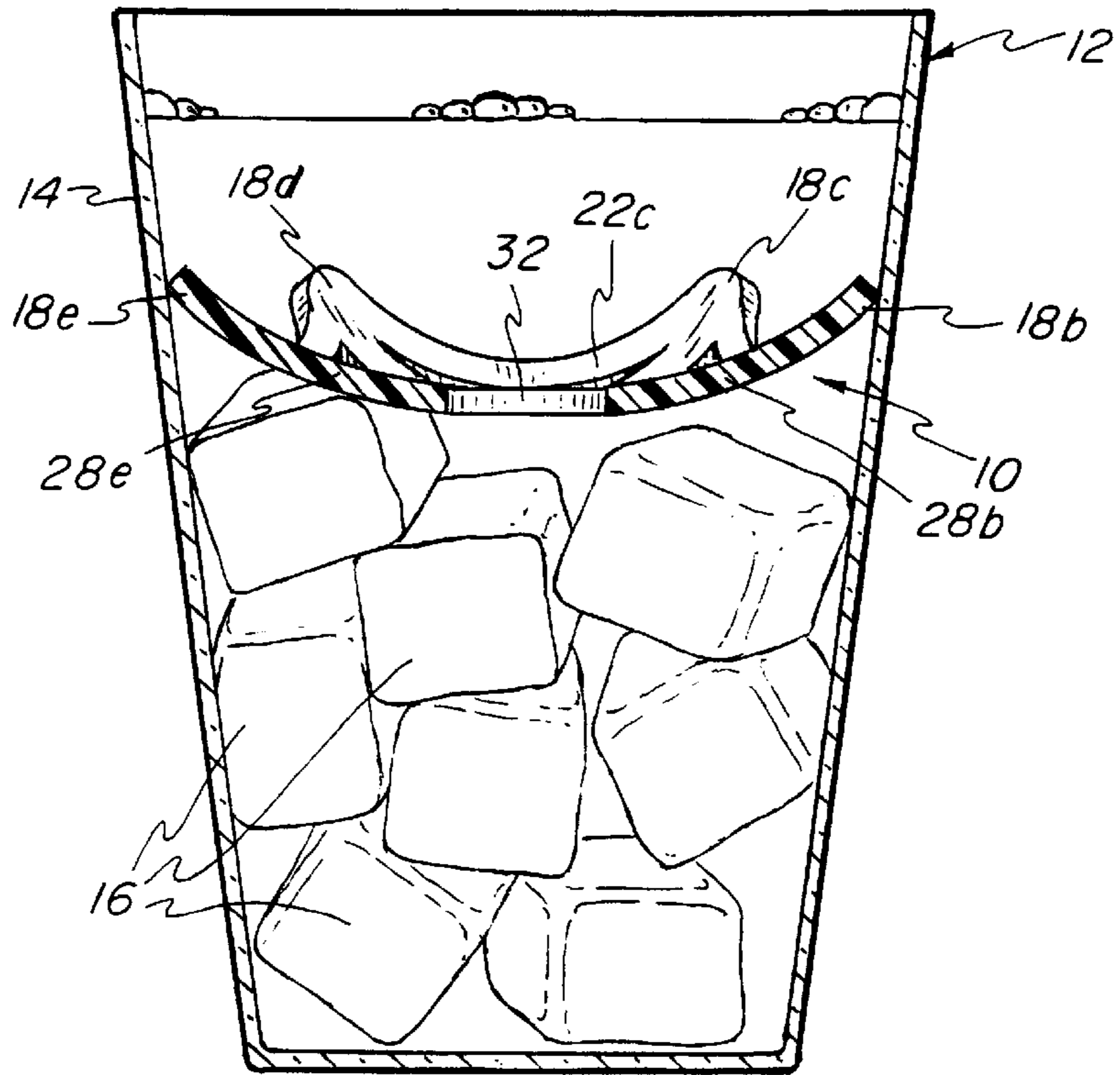

FIG - 3

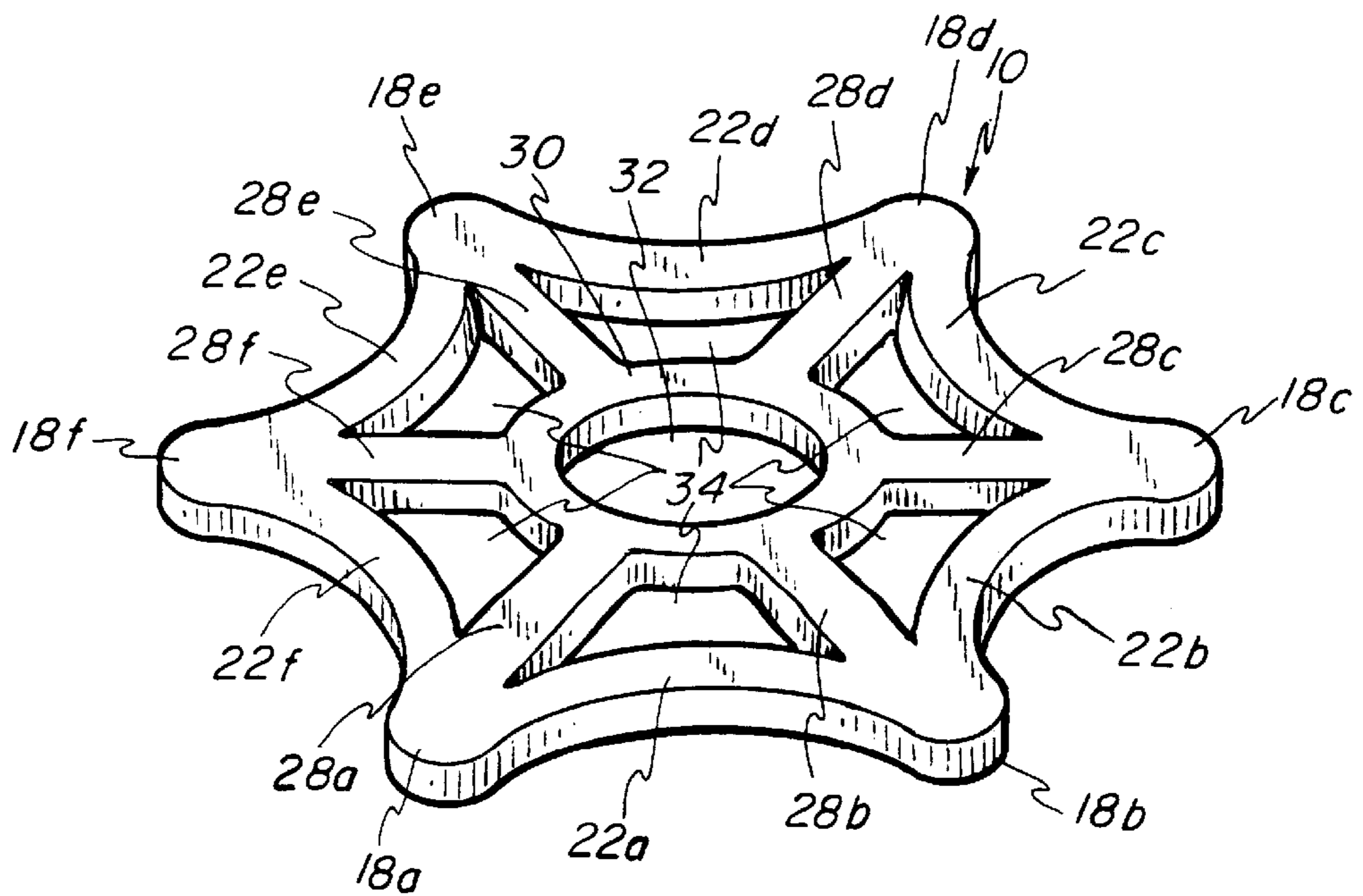

FIG - 4

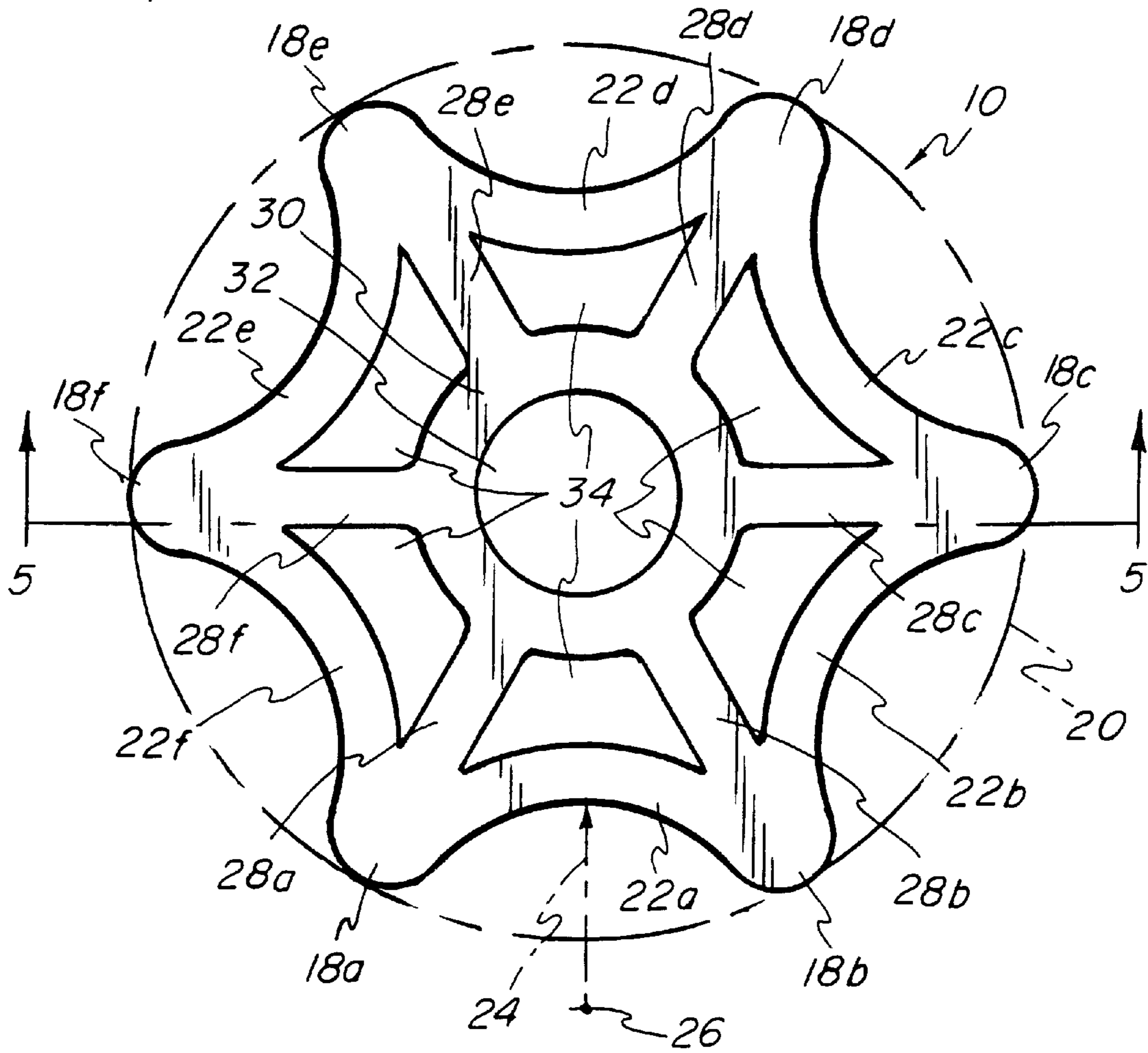

FIG-5

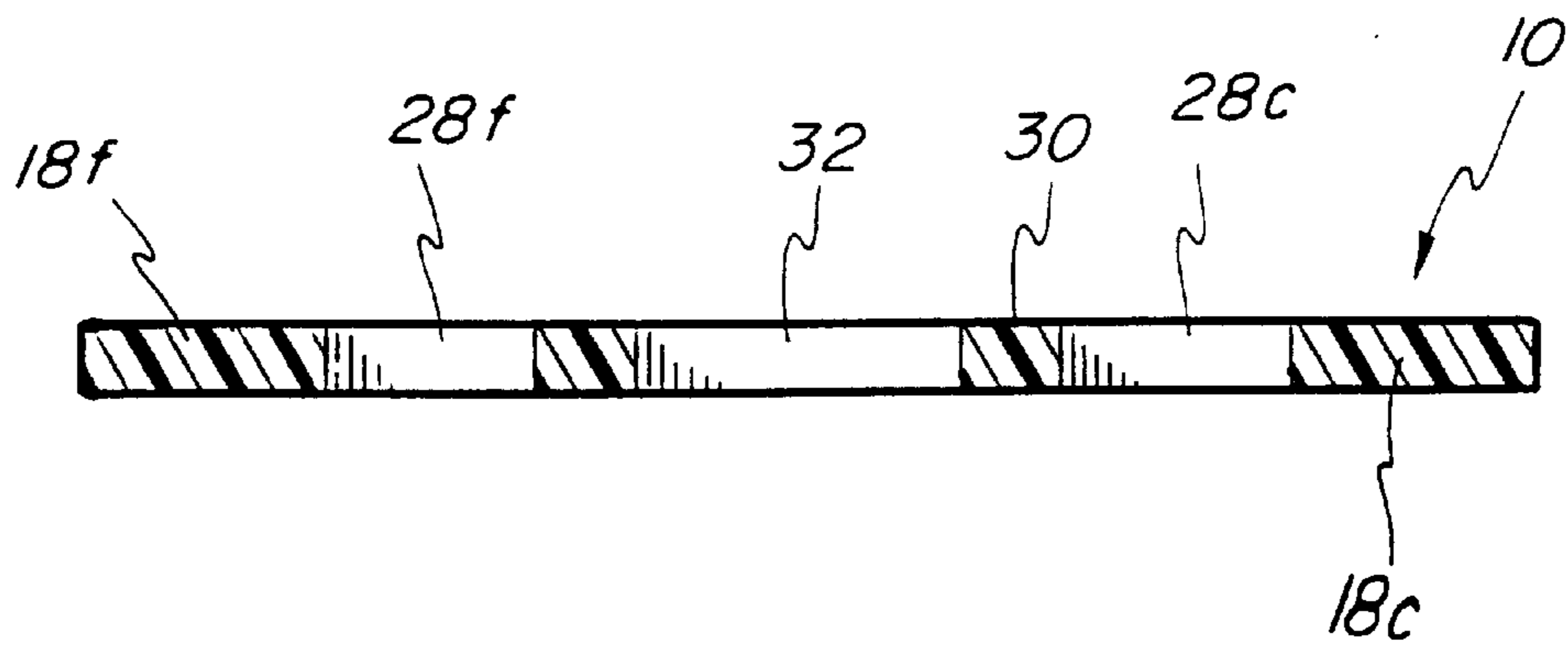
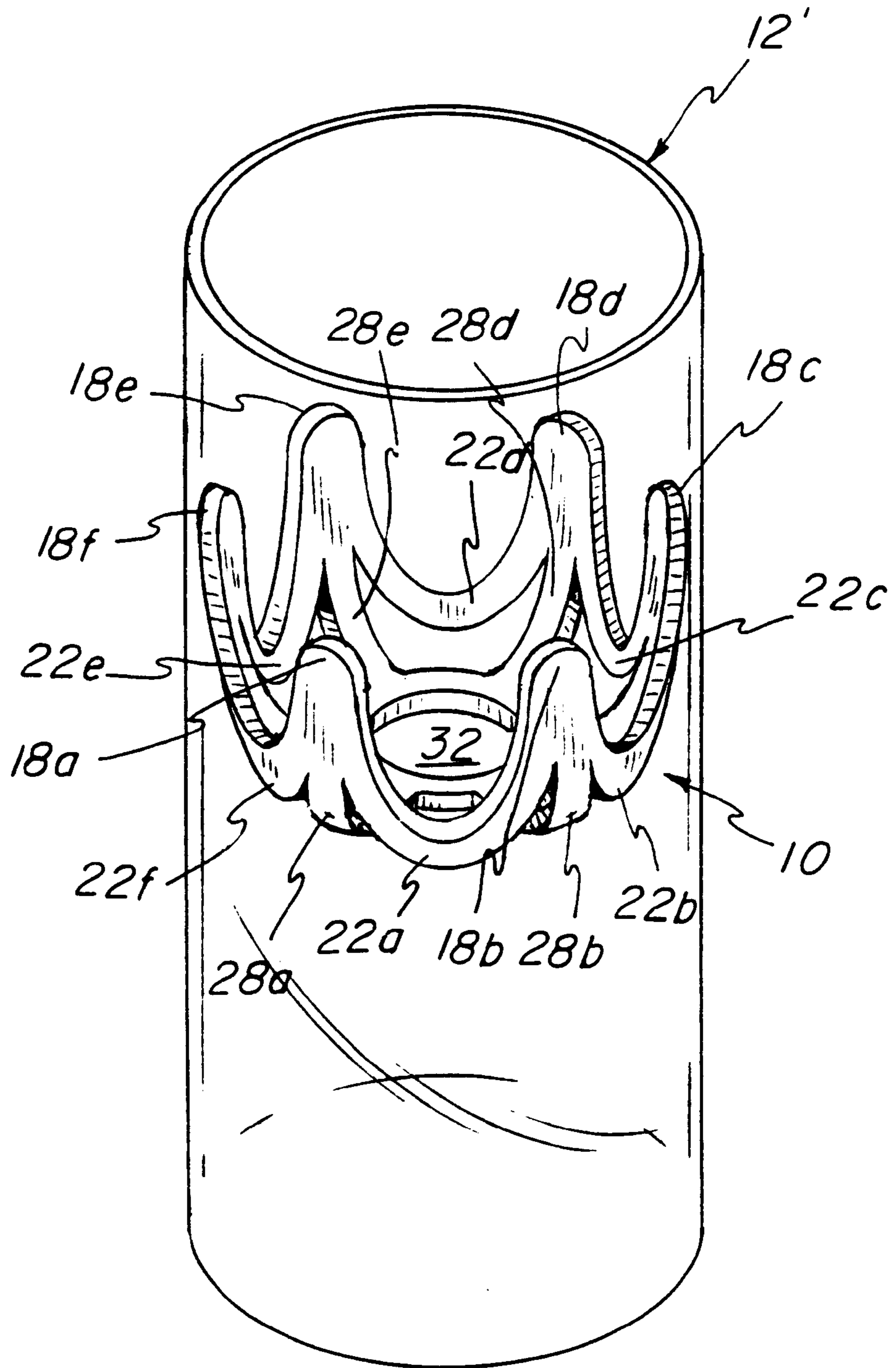

FIG - 6



ICE CUBE RESTRAINING DEVICE**FIELD OF THE INVENTION**

The present invention relates to accessories for use with drink containers and, more particularly, to devices adapted to be positioned within drink containers for restraining objects, such as ice cubes, within the containers.

BACKGROUND OF THE INVENTION

A long recognized need for glasses or drink containers containing solid objects, such as ice cubes or the like relates to the ability to provide a mechanism for restraining the objects in the container while permitting sufficient flow of the drink from the container. Various devices have been proposed to accomplish this task with varying results.

For example, U.S. Pat. No. 1,173,374 to Nolda discloses a device for retaining ice in a glass wherein the device comprises a resilient outer ring supporting inwardly extending prongs. The device is formed with a conical shaped outer wall for frictional engagement with the inner surface of a glass, and therefore is limited to use in combination with drinking vessels having walls angled similar to the angle of the outer wall of the device.

U.S. Pat. No. 3,752,320 to Biro discloses a device for holding ice in a glass wherein the disclosed device is a molded plastic unit forming a screen, and a U-shaped portion at a center portion of the device acts as a spring to bias the device against the sides of the drinking glass. This device is limited in its range of use by the range of travel of the U-shaped spring member, such that the device may be used only with a limited range of drinking glass diameters.

U.S. Pat. No. 4,938,375 to Fantacone discloses a drinking receptacle and ice trap for use in combination with one another wherein the trap includes a side section for engaging the sides of a glass and a bottom section, the side and bottom sections are formed with concentrically arranged openings. The drink receptacle is specifically formed with an internal annular lip for cooperating with a rim on the trap such that the trap is not designed for use with a wide range of drink vessels.

U.S. Pat. No. 4,842,157 to Stone-Parker et al. attempts to address the shortcomings of the previously mentioned prior art and provides a retainer device for insertion in a drinking container wherein the device includes a solid central portion with S-shaped arms extending radially outwardly for engagement with the interior of a drink container. The arms are preferably provided with a rubber tip on the ends thereof for engaging glass and plastic drink containers. While this device provides an advantage over prior art devices in increasing the range of drink containers that the device may be used in, it is still limited in that the S-shaped or double curved arms, which are formed of plastic, will only be adapted to flex to a certain degree for insertion into smaller diameter drink containers, as limited by the dimensions and stiffness of the plastic material forming the arms.

Accordingly, there remains a need for a device for restraining ice in a drink container wherein the device is adapted to be used in a wide range of drink container sizes and which is of simple construction formed of a single homogeneous material, and not requiring a specially designed container to hold the device in place.

SUMMARY OF THE INVENTION

The present invention provides an ice cube restraining device for use in combination with a drink container having

generally upright sides. The device includes a plurality of contact patches for engaging an interior surface of the drink container wherein the plurality of contact patches are substantially equally spaced from each other in a circumferential direction around an area circumscribed by an imaginary circle touching the outer edges of the contact patches. The contact patches are designed to engage the drink container at discrete locations for holding the restraining device at a desired vertical position within the container.

Flexible circumferential web pieces extend between adjacent pairs of the contact patches to exert a circumferentially extending force on the contact patches whereby the contact patches are supported, in a circumferential direction, by two of the circumferential web pieces. The contact patches are further supported in a radial direction by radial web pieces wherein a radial web piece extends radially inwardly toward a center portion of the restraining device from each of the contact patches. A central hoop member is engaged with the inner ends of each of the radial web pieces to provide a radial biasing force to each of the radial web pieces for controlling radial movement of the contact patches.

The central hoop member circumscribes a circular aperture at the center of the restraining device, and provides a flexible support for the inner ends of the web pieces wherein the central hoop member will flex and twist as the radial web pieces and contact patches are forced radially inwardly during insertion into a drink container. While the central hoop member, radial web pieces and circumferential web pieces provide support for the contact patches, the central circular aperture and an open annular area between the circumferential web pieces and the central hoop member provide a substantial unrestricted opening for fluid to flow past the restraining device.

The restraining device is formed of a highly flexible material which elastically deforms from a flat configuration to an upwardly concave configuration when in use positioned within a drink container. The highly flexible nature of the restraining device of the present invention permits the device to be used in a wide range of drink container diameters, and further facilitates easy insertion and removal of the device from the drink containers.

Therefore, it is an object of the present invention to provide a restraining device for use in a wide range of drink containers.

It is another object of the invention to provide a restraining device which is highly flexible and easily inserted into and removed from drink containers.

It is yet another object of the invention to provide a restraining device which is easily manufactured from a single homogeneous material.

Other objects and advantages of the invention will be apparent from the following description, the accompanying drawings and the appended claims.

BRIEF DESCRIPTION OF THE DRAWINGS

FIG. 1 is a perspective view of the ice cube restraining device of the present invention positioned in a large diameter glass;

FIG. 2 is an elevational cross-sectional view thereof;

FIG. 3 is a perspective view of the ice cube restraining device in its non-use configuration;

FIG. 4 is a top plan view thereof;

FIG. 5 is a cross-sectional view taken along line 5—5 in FIG. 4; and

FIG. 6 is a perspective view of the ice cube restraining device positioned in a small diameter glass.

DETAILED DESCRIPTION OF THE PREFERRED EMBODIMENT

Referring to FIGS. 1 and 2, the present invention provides an ice cube restraining device **10** for use in combination with a drink container **12** having generally upright sides and preferably comprising a drinking glass having generally cylindrical sides **14**. The restraining device **10** is adapted to be positioned within the drink container **12** and engaged with the interior surface of the sides **14** for retaining ice cubes **16** in a bottom portion of the drink container **12** while permitting fluid to flow freely through the restraining device **10** whereby ice cubes may be held immovably within the container **12** to prevent the ice cubes from sloshing or suddenly moving when the container **12** is tipped for drinking by a person.

Referring additionally to FIGS. 3-5, the ice restraining device **10** includes a plurality of discrete contact patches **18a-f** for engaging the interior surface of the drink container **12**. The contact patches **18a-f** are substantially equally spaced from each other in a circumferential direction within an area circumscribed by an imaginary circle **20** tangentially extending around the contact patches **18**. It should be noted that although six contact patches **18** are illustrated in the drawings, the present invention is not limited to this particular number of contact patches **18** and any number of contact patches **18** which function in the manner described herein are considered within the scope of this invention.

A plurality of flexible circumferential web pieces **22a-f** are formed integrally with the contact patches **18** wherein each of the circumferential web pieces **22a-f** extend between adjacent pairs of the contact patches **18a-f** such that each of the contact patches **18a-f** is supported, in a circumferential direction, by two of the circumferential web pieces **22a-f**. The circumferential web pieces **22a-f** define arcuate members, each having a center of curvature located radially outwardly from a respective circumferential web piece, as is illustrated by radius line **24** extending from the center of curvature **26** for the circumferential web piece **22a**. The circumferential web pieces **22** maintain the spacing between the contact patches to facilitate controlled movement of the contact patches **18** and avoid unwanted sideways distortion during insertion of the restraining device **10** in a drink container **12**.

A plurality of flexible radial web pieces **28a-f** are formed integrally with respective contact patches **18a-f** and extend radially inwardly from the respective contact patches **18a-f**. Inner ends of the radial web pieces **28** are integrally connected to a central hoop member **30** whereby the radial web pieces **28a-f** support the respective contact patches **18a-f** in a radial direction. The central hoop member **30** circumscribes a circular aperture **32**, and the central hoop member is formed as a flexible member capable of twisting and bending movement in the radial and vertical directions to accommodate flexing of the restraining device **10** during insertion into a drink container **12** while also providing a stable support for biasing the contact patches **18** in the radial direction.

In addition, each of the radial web pieces **28a-f** are formed having a width dimension, measured in the circumferential direction, which is greater than the width dimension of the contact patches **18a-f**, and which is greater than the vertical thickness dimension of the radial web pieces. In this manner, the radial web pieces **28** are formed as highly flexible members for flexing in a vertical direction perpendicular to the horizontal plane of the restraining device **10**.

It should be noted that an open annular area **34** is defined between the circumferential web pieces **22** and the central

hoop member **30** wherein the annular area **34** accommodates inward flexing of the circumferential web pieces **22**. Also, the open annular area **34** and circular aperture **32** provide open areas through which fluids may freely flow through the restraining device **10** when it is positioned within a drink container **12**.

The restraining device **10** is preferably formed of a single homogeneous polymeric material molded as an integral unit and is preferably formed of 55 durometer PVC. It should be understood that other materials may be used to provide a functional device and the restraining device **10** may be formed of other flexible, resilient materials having a durometer within the range of about 35-70 within the scope of the present invention. The main criteria for the material of the device being that it is highly elastic and of sufficient resiliency to provide good frictional engagement against the surface of a drinking glass while also providing sufficient rigidity to cause the device to bias the contact patches **18** against the sides of a glass or other drink container and to return to its normal configuration when not in use.

The restraining device **10** has a flat non-use configuration wherein the plurality of contact patches **18**, the circumferential web pieces **22**, the radial web pieces **28** and the central hoop member **30** all lie in a common plane, as is best seen in FIG. 5.

In addition, it can be seen that the device **10** is formed as a relatively thin structure which, in combination with the material comprising the device **10**, enables the device **10** to function as a flexible structure which readily conforms to the interior of various drink containers.

In a use configuration of the restraining device **10**, the restraining device **10** takes on a smooth concave curve configuration with the contact patches **18** engaging the interior surface of a drink container **12**, **12'**, as is best seen in FIGS. 2 and 6. FIG. 2 illustrates the restraining device **10** engaged with a drink container **12** which is of a maximum diameter the restraining device **10** is adapted to be used with, and FIG. 6 illustrates the restraining device **10** positioned in a container **12'** having a minimum diameter the restraining device **10** is adapted to be used with. In the preferred embodiment, the restraining device **10** has a non-use diameter, as defined by the imaginary circle **20**, of approximately 3½ inches, and the restraining device **10** is adapted to be used within drink containers having diameters ranging from about ¾ inches to about 2 inches. Thus, the restraining device **10** is designed for use within containers having diameters ranging from about 93% to about 57% of the diameter of the imaginary circle **20** defined when the restraining device **10** is in its flat non-use configuration. Accordingly, the present invention provides a restraining device **10** which is designed to be used within drink containers having a wide range of diameters not heretofore provided by prior art ice restraining devices.

In use, the restraining device **10** may be grasped through the circular aperture **32** and inserted into a drink container **12** wherein the center of the restraining device is flexed downwardly, and the degree of downward flexing is dependent upon the particular diameter of the drink container **12**. The spacing and outward biasing of the contact patches **18** is maintained through the circumferential and radial web pieces **18** and **28** in cooperation with the central hoop member **30** to maintain a sufficient outward biasing force on the contact patches **18** to maintain frictional engagement with the interior surface of the drink container **12** and, as can be seen by comparing FIGS. 2 and 6, the open annular area **34** is designed to accommodate varying degrees of flexing by the circumferential web pieces **22**.

In addition to being highly adaptable to various drink containers, the flat non-use configuration of the present ice cube restraining device permits the device to be easily packaged and stored in a minimum of space.

While the form of apparatus herein described constitutes a preferred embodiment of this invention, it is to be understood that the invention is not limited to this precise form of apparatus, and that changes may be made therein without departing from the scope of the invention which is defined in the appended claims.

What is claimed is:

1. An ice cube restraining device for use in combination with a drink container having generally upright sides, said restraining device comprising:

- a plurality of contact patches for engaging an interior surface of a drink container, said plurality of contact patches being substantially equally spaced from each other in a circumferential direction within an area circumscribed by an imaginary circle;
- a flexible circumferential web piece extending between adjacent pairs of said contact patches such that each contact patch is supported, in a circumferential direction, by two of said circumferential web pieces;
- a flexible radial web piece extending radially inwardly from each of said contact patches for supporting respective ones of said contact patches in a radial direction;
- a central hoop member engaged with inner ends of said radial web pieces wherein an annular area is defined between said circumferential web pieces and said central hoop member; and

wherein, in the absence of forces applied to said restraining device, said restraining device is substantially flat and, in a use position with said contact patches pressed inwardly and held in position by an interior surface of a drink container, said restraining device defines a smooth concave curve extending across the entire width of said restraining device.

2. The restraining device of claim **1** wherein said circumferential web pieces are spaced radially inwardly from said imaginary circle circumscribing said contact patches.

3. The restraining device of claim **2** wherein said circumferential web pieces are arcuate and each circumferential web piece is formed with a center of curvature located radially outwardly from a respective circumferential web piece.

4. The restraining device of claim **1** wherein each said contact patch defines a width, in the circumferential direction, which is greater than a width defined by a respective radial web piece, in the circumferential direction.

5. The restraining device of claim **1** wherein, in the use position, said restraining device is adapted to be flexed to engage interior surfaces of drink containers having interior diameters ranging from about 93 percent to about 57 percent of the diameter of the area circumscribed by the imaginary circle when said restraining device is flat.

6. The restraining device of claim **1** wherein restraining device is formed of a flexible, resilient material having a durometer of about 35 to 70.

7. The restraining device of claim **6** wherein said material comprises PVC.

8. The restraining device of claim **1** wherein said central hoop member circumscribes a circular aperture and provides a flexible support for said inner ends of said radial web pieces.

9. An ice cube restraining device for use in combination with a drink container having generally upright sides, said restraining device comprising:

a plurality of contact patches for engaging an interior surface of a drink container, said plurality of contact patches being substantially equally spaced from each other in a circumferential direction within an area circumscribed by an imaginary circle;

a plurality of flexible circumferential web pieces, each said circumferential web piece extending between adjacent pairs of said contact patches such that each said contact patch is supported, in a circumferential direction, by two of said circumferential web pieces, and each said circumferential web piece defining an arcuate member having a center of curvature located radially outwardly from a respective circumferential web piece;

a plurality of flexible radial web pieces, each said radial web piece extending radially inwardly from a respective one of said contact patches for supporting respective ones of said contact patches in a radial direction; and

a central hoop member engaged with inner ends of said radial web pieces wherein an annular area is defined between said circumferential web pieces and said central hoop member; and

wherein, in the absence of forces applied to said restraining device, said restraining device is substantially flat and, in a use position with said contact patches pressed inwardly and held in position by an interior surface of a drink container, said restraining device defines a smooth concave curve extending across the entire width of said restraining device.

10. The restraining device of claim **9** wherein each said contact patch defines a width, in the circumferential direction, which is greater than a width defined by a respective radial web piece, in the circumferential direction.

11. The restraining device of claim **9** wherein, in the use position, said restraining device is adapted to be flexed to engage interior surfaces of drink containers having interior diameters ranging from about 93 percent to about 57 percent of the diameter of the area circumscribed by the imaginary circle when said restraining device is flat.

12. The restraining device of claim **9** wherein restraining device is formed of a flexible, resilient material having a durometer of about 35 to 70.

13. The restraining device of claim **12** wherein said material comprises PVC.

14. The restraining device of claim **9** wherein said central hoop member circumscribes a circular aperture and provides a flexible support for said inner ends of said radial web pieces.

15. An ice cube restraining device for use in combination with a drink container having generally upright sides, said restraining device formed of a polymeric material having a durometer of about 55 and comprising:

a plurality of discrete contact patches for engaging an interior surface of a drink container, said plurality of contact patches being substantially equally spaced from each other in a circumferential direction within an area circumscribed by an imaginary circle;

a plurality of flexible circumferential web pieces formed integrally with said contact patches, each said circumferential web piece extending between adjacent pairs of said contact patches such that each said contact patch is supported, in a circumferential direction, by two of said circumferential web pieces, and each said circumferential web piece defining an arcuate member having a center of curvature located radially outwardly from a respective circumferential web piece;

7

a plurality of flexible radial web pieces, each said radial web piece formed integrally with and extending radially inwardly from a respective one of said contact patches for supporting respective ones of said contact patches in a radial direction; 5

a central hoop member circumscribing a circular aperture and formed integrally with inner ends of said radial web pieces wherein an open annular area is defined between said circumferential web pieces and said central hoop member; and 10

wherein said restraining device has a flat non-use configuration and a curved use configuration such that in said non-use configuration, said plurality of contact

8

patches, said circumferential web pieces, said radial web pieces and said central hoop member all lie in a common plane, and in said use configuration, said restraining device defines a smooth concave curve with said contact patches lying within an area circumscribed by an imaginary circle having a maximum diameter ranging from about 93 percent to about 57 percent of the diameter of an imaginary circle circumscribing outer portions of said contact patches positioned in said flat non-use configuration.

* * * * *