



US005967508A

# United States Patent [19] Olexy

[11] **Patent Number:** **5,967,508**

[45] **Date of Patent:** **Oct. 19, 1999**

[54] **FILM SHEET PICKER ASSEMBLY**

[75] Inventor: **Anthony M. Olexy**, Honeoye Falls, N.Y.

[73] Assignee: **Eastman Kodak Company**, Rochester, N.Y.

[21] Appl. No.: **08/976,856**

[22] Filed: **Nov. 24, 1997**

[51] **Int. Cl.**<sup>6</sup> ..... **B65H 5/08**; B65H 3/46; B65H 3/08

[52] **U.S. Cl.** ..... **271/106**; 271/11; 271/107

[58] **Field of Search** ..... 271/11, 106, 107

[56] **References Cited**

**U.S. PATENT DOCUMENTS**

3,039,767	6/1962	Staines	.....	271/106
3,669,445	6/1972	Wallis	.....	271/26 X
4,585,222	4/1986	Nishibori et al.	.....	271/106
4,968,019	11/1990	Tanaby et al.	.....	271/106
5,127,645	7/1992	Torisawa	.....	271/11

*Primary Examiner*—William E. Terrell  
*Assistant Examiner*—Ku Bower  
*Attorney, Agent, or Firm*—William F. Noval

[57] **ABSTRACT**

A film sheet picker assembly comprising: a picker member which is movable into and out of proximity with the top film sheet of a stack of film sheets; a plurality of vacuum cups rotatably mounted on the picker member; means for biasing the plurality of vacuum cups at an angle relative to the top surface of the top film sheet; a roller assembly operatively associated with the plurality of vacuum cups; and a control for moving the picker member into proximity with the top film sheet of a stack of film sheets, such that the roller assembly contacts the top film sheet and rotates the plurality of vacuum cups into vacuum engagement with the top film sheet and for moving the picker member out of proximity with the stack of film sheets such that the biasing means rotates the vacuum cups to move the top film sheet out of contact with the stack of film sheets.

**3 Claims, 14 Drawing Sheets**

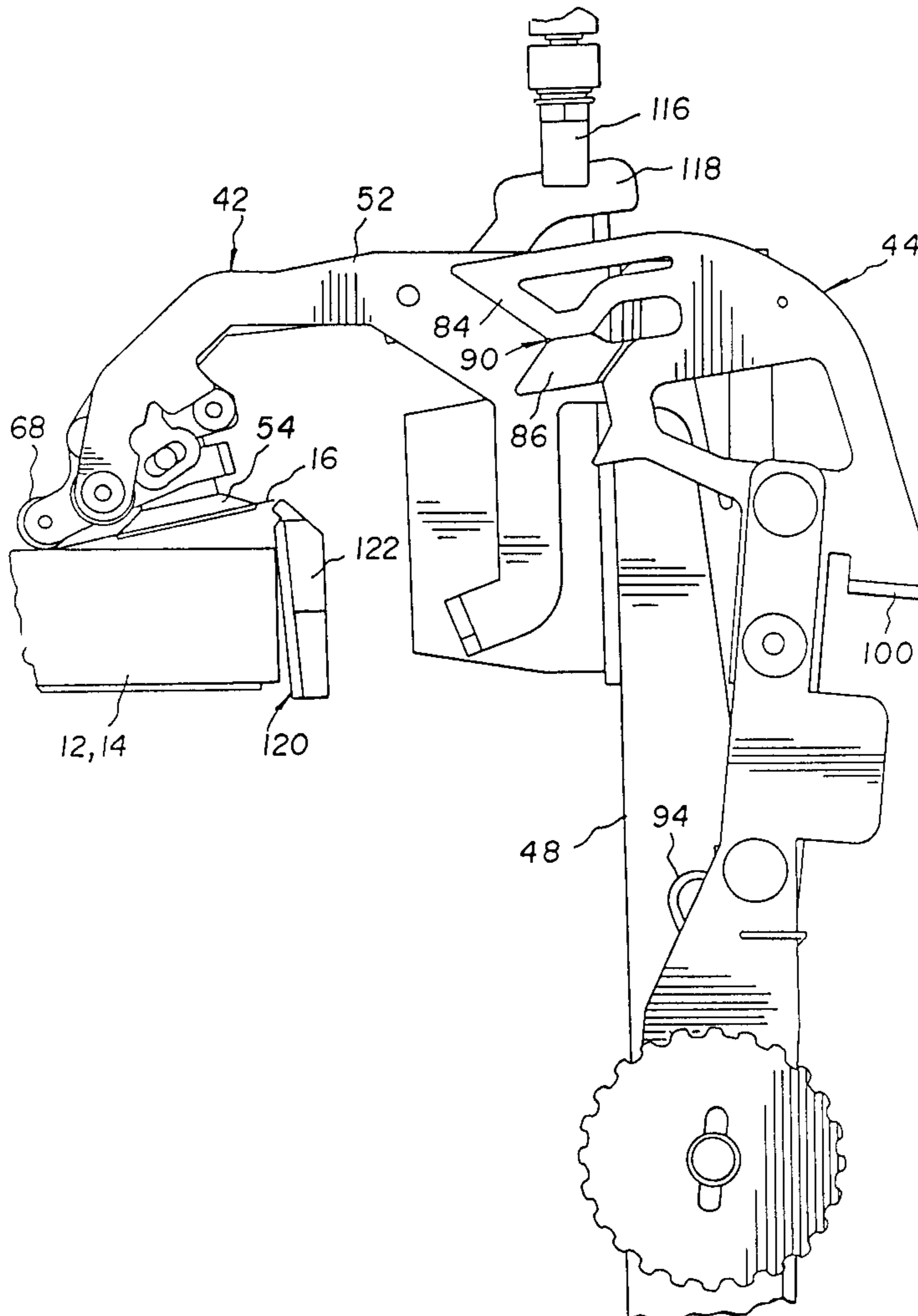

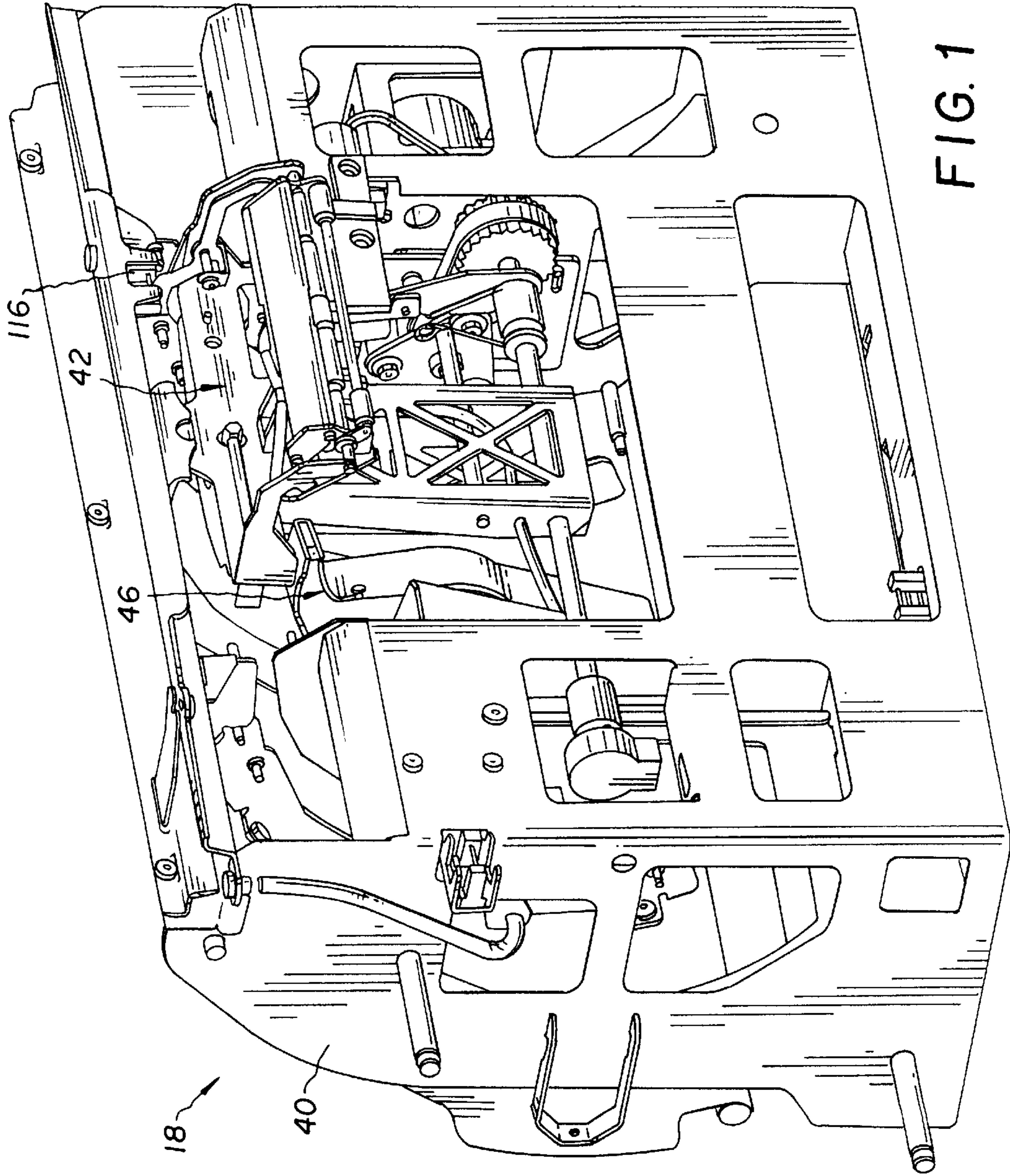
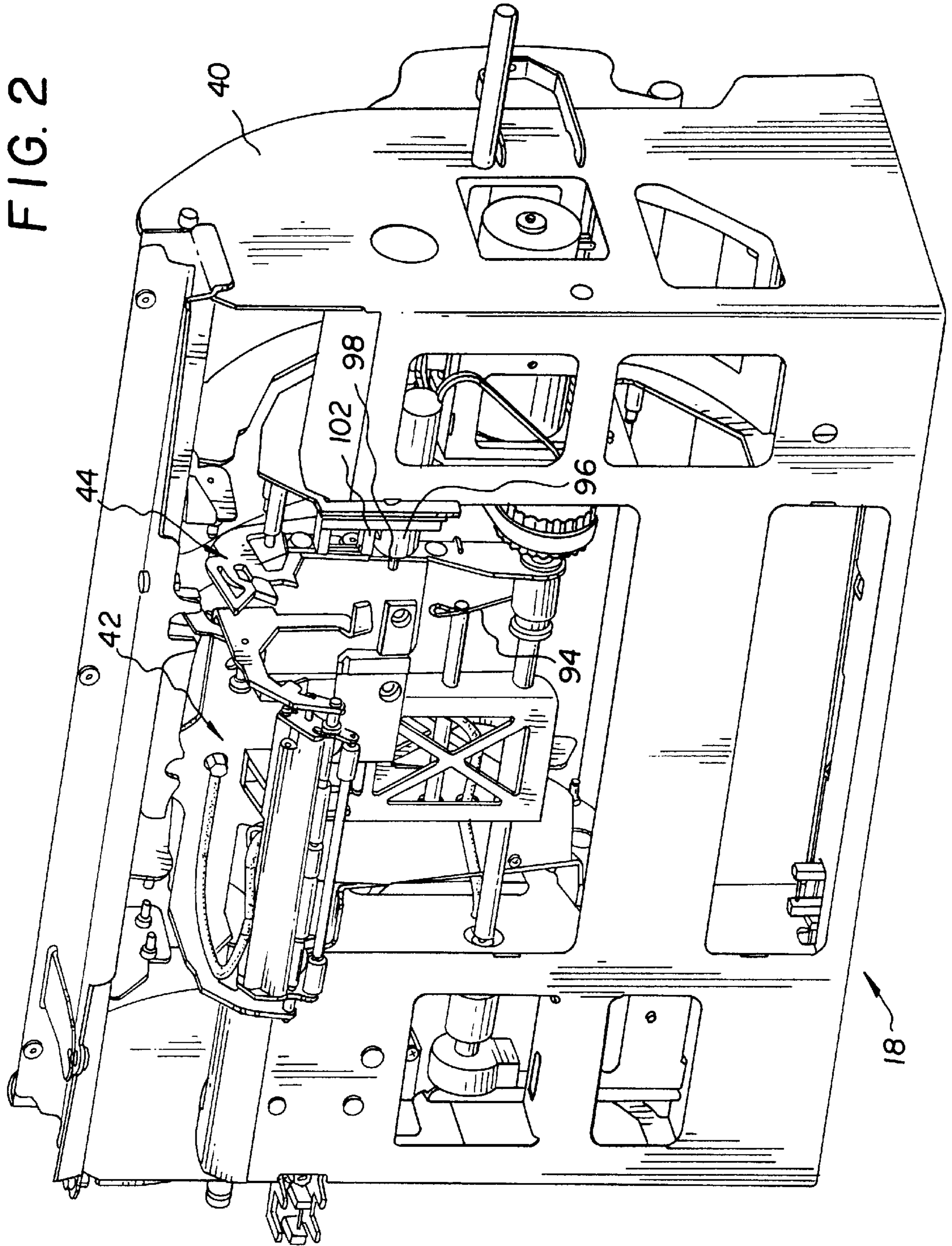

FIG. 2



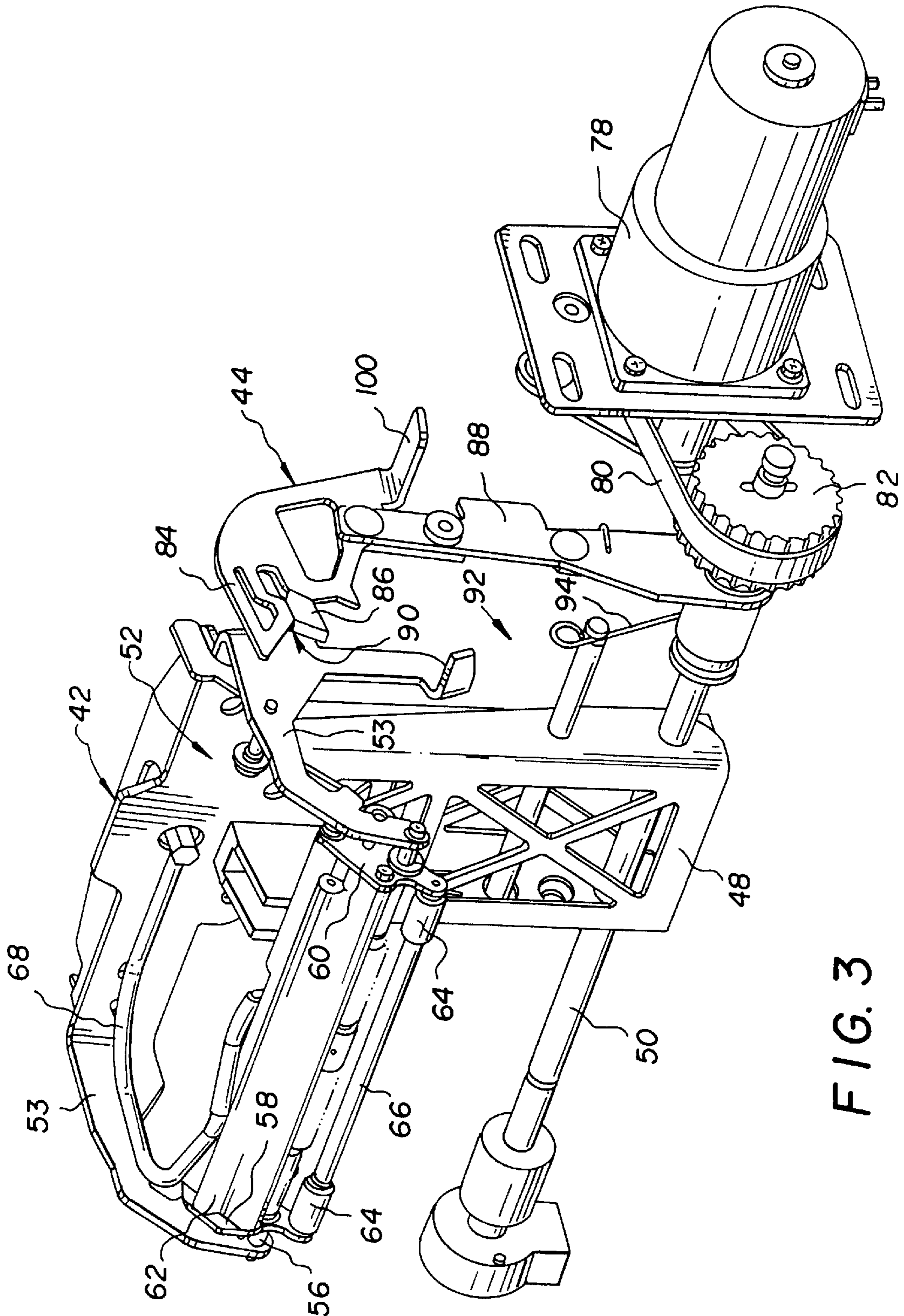
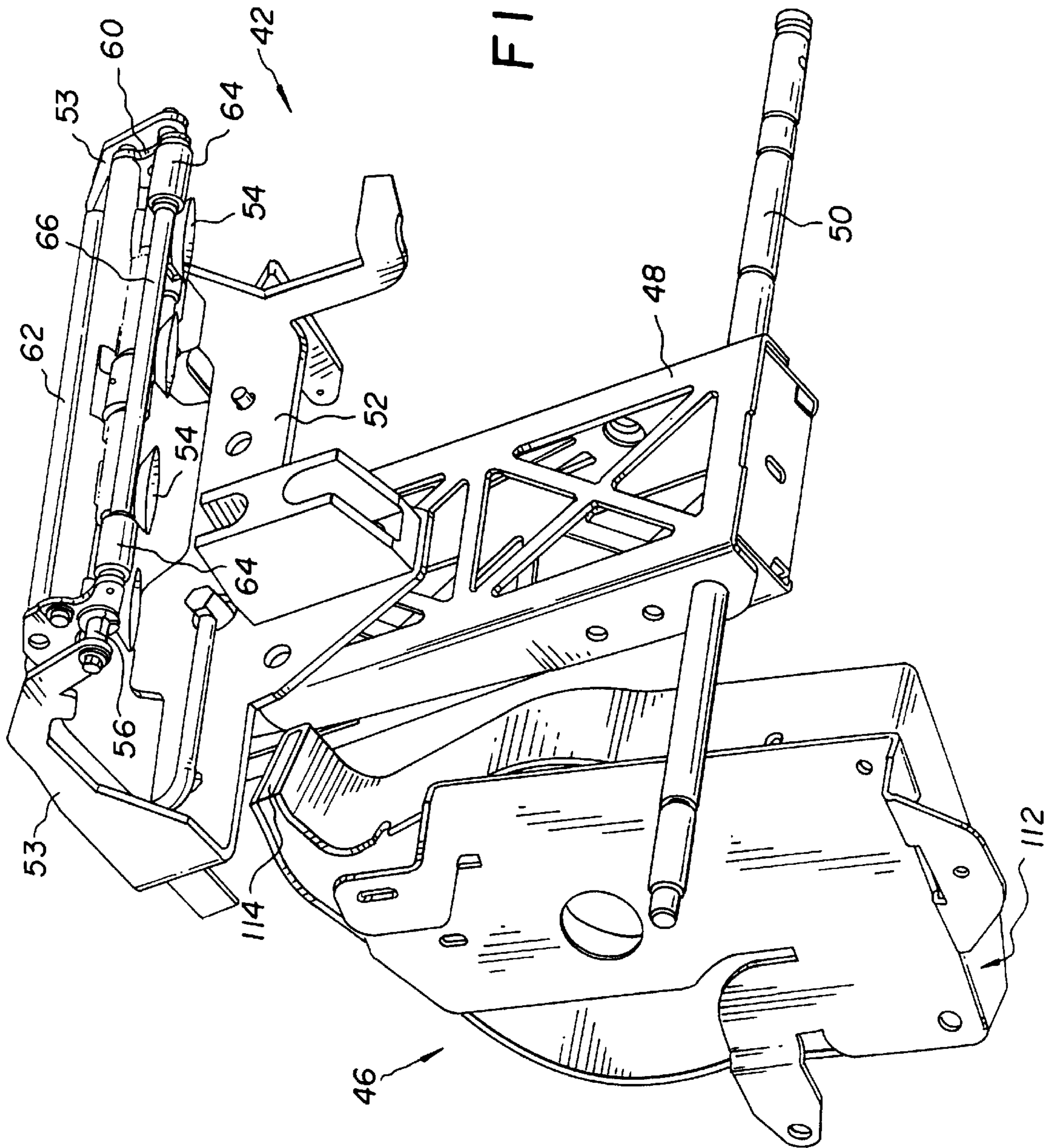

FIG. 3

FIG. 4



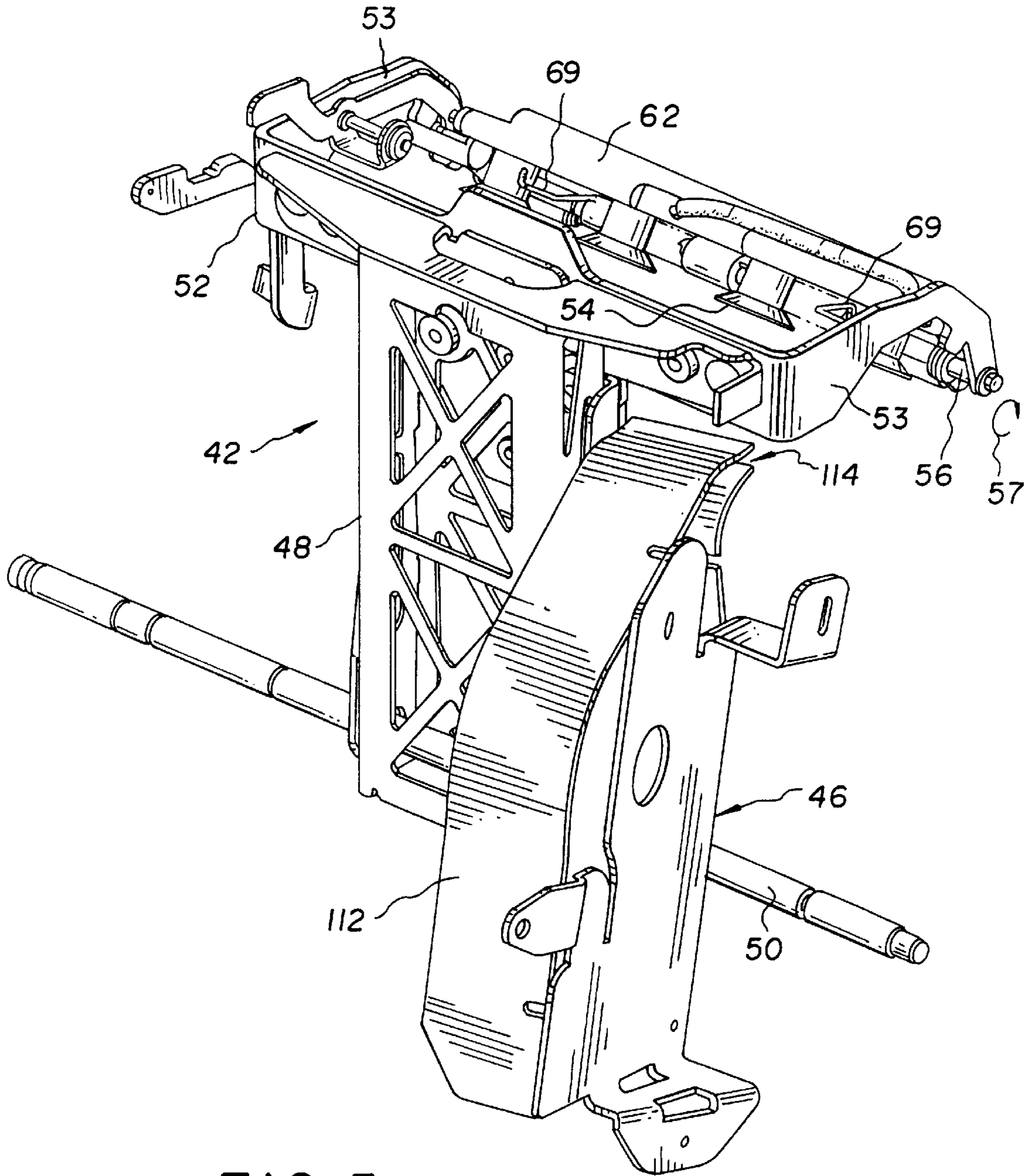

FIG. 5

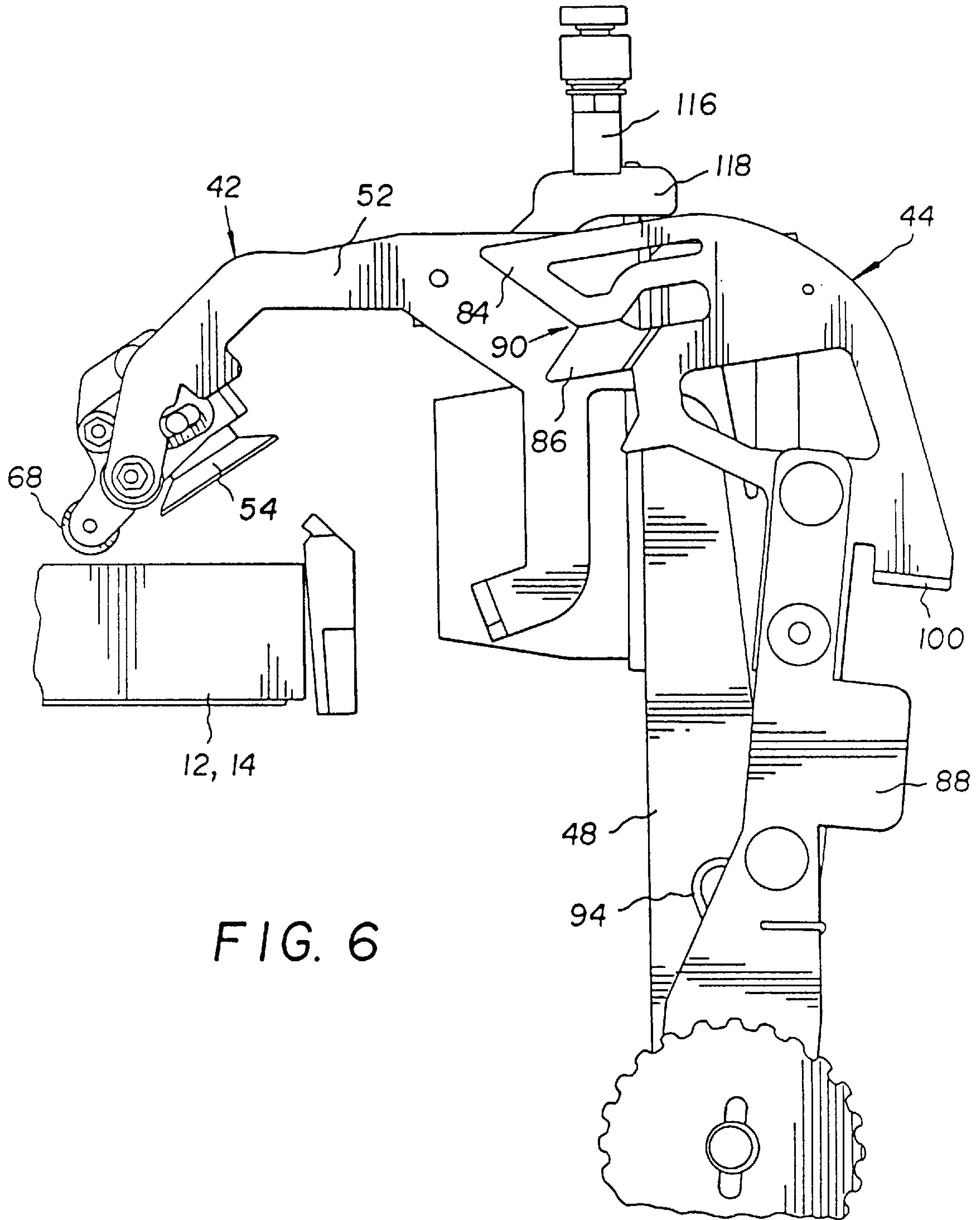

FIG. 6

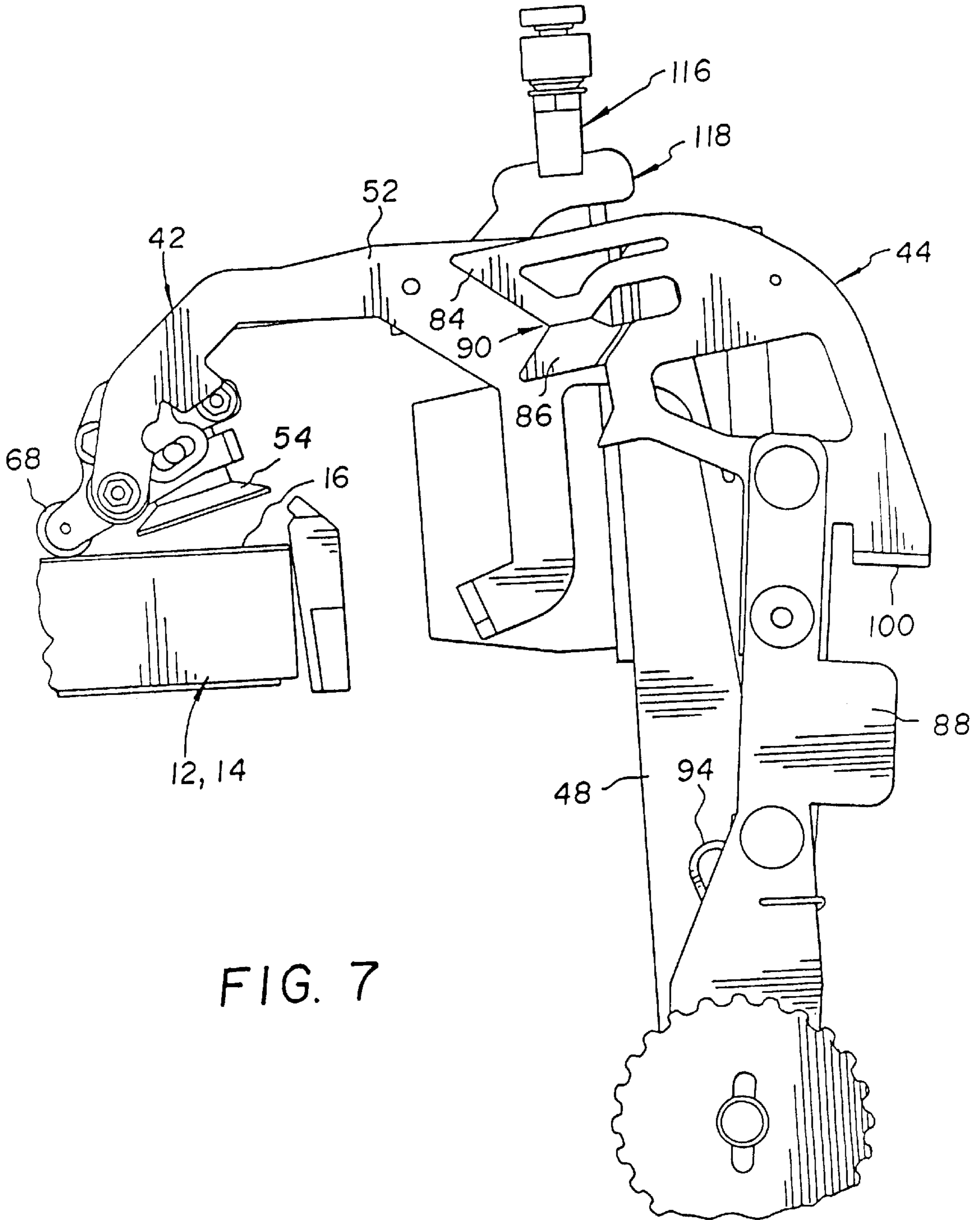

FIG. 7



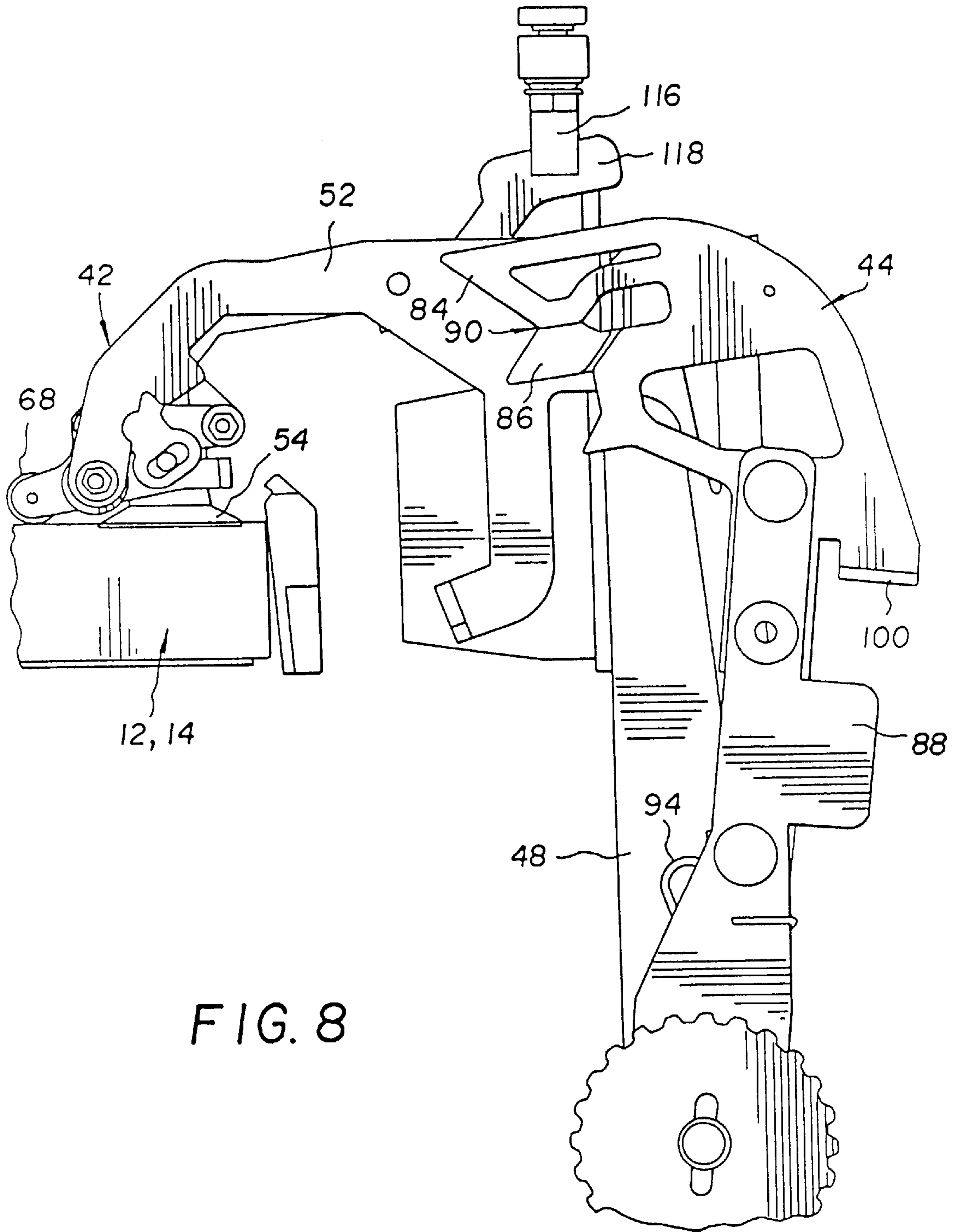

FIG. 8

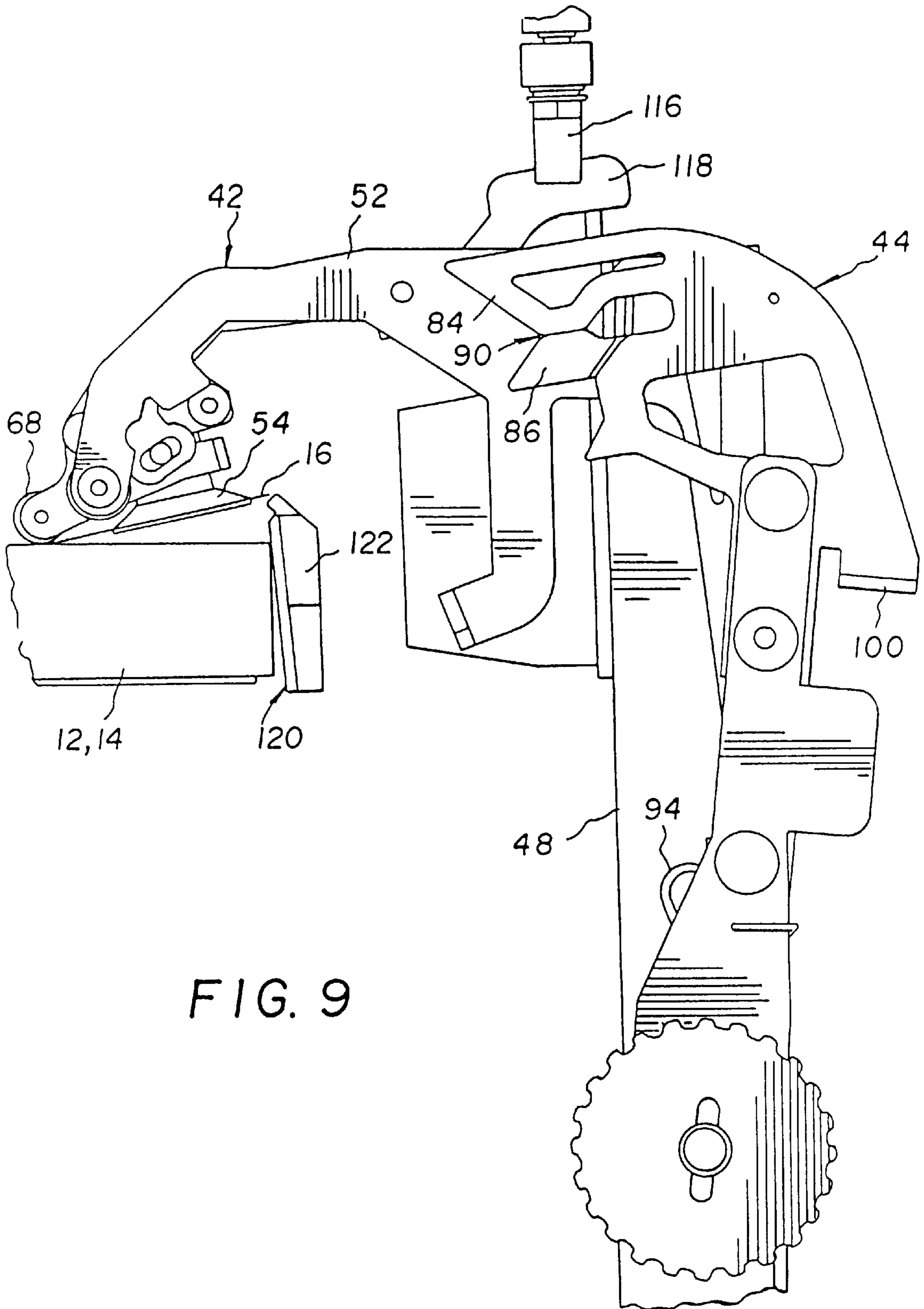

FIG. 9

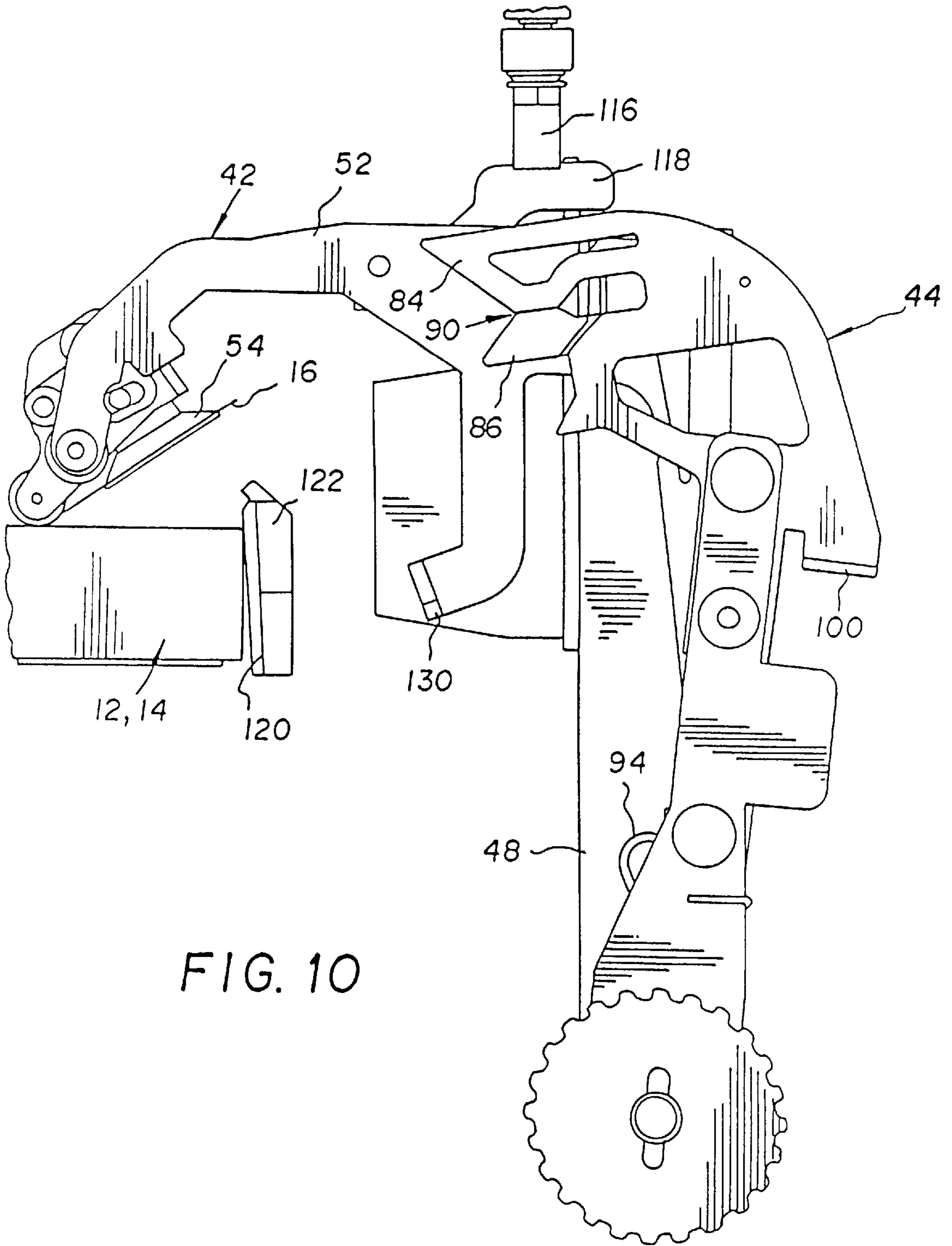

FIG. 10

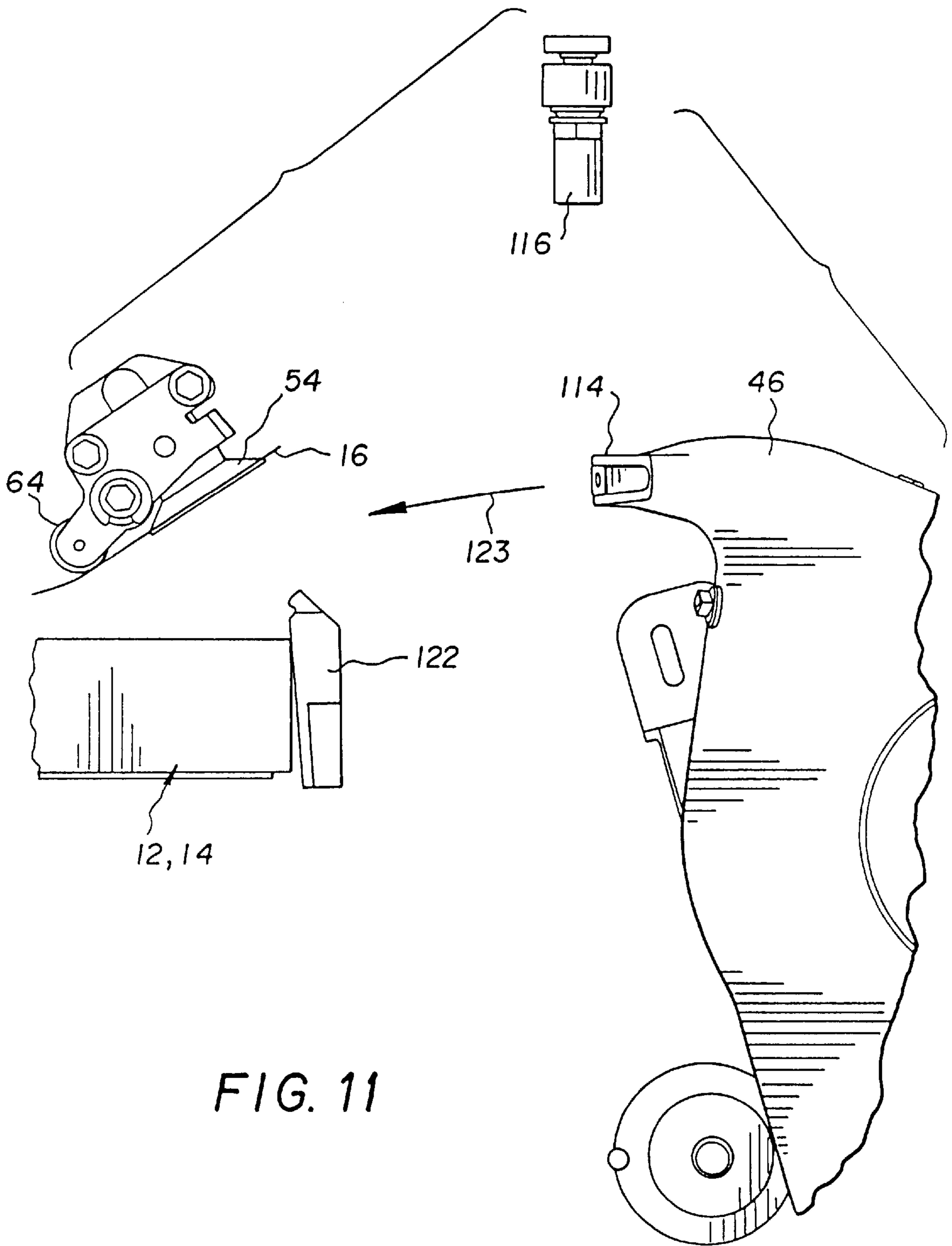

FIG. 11

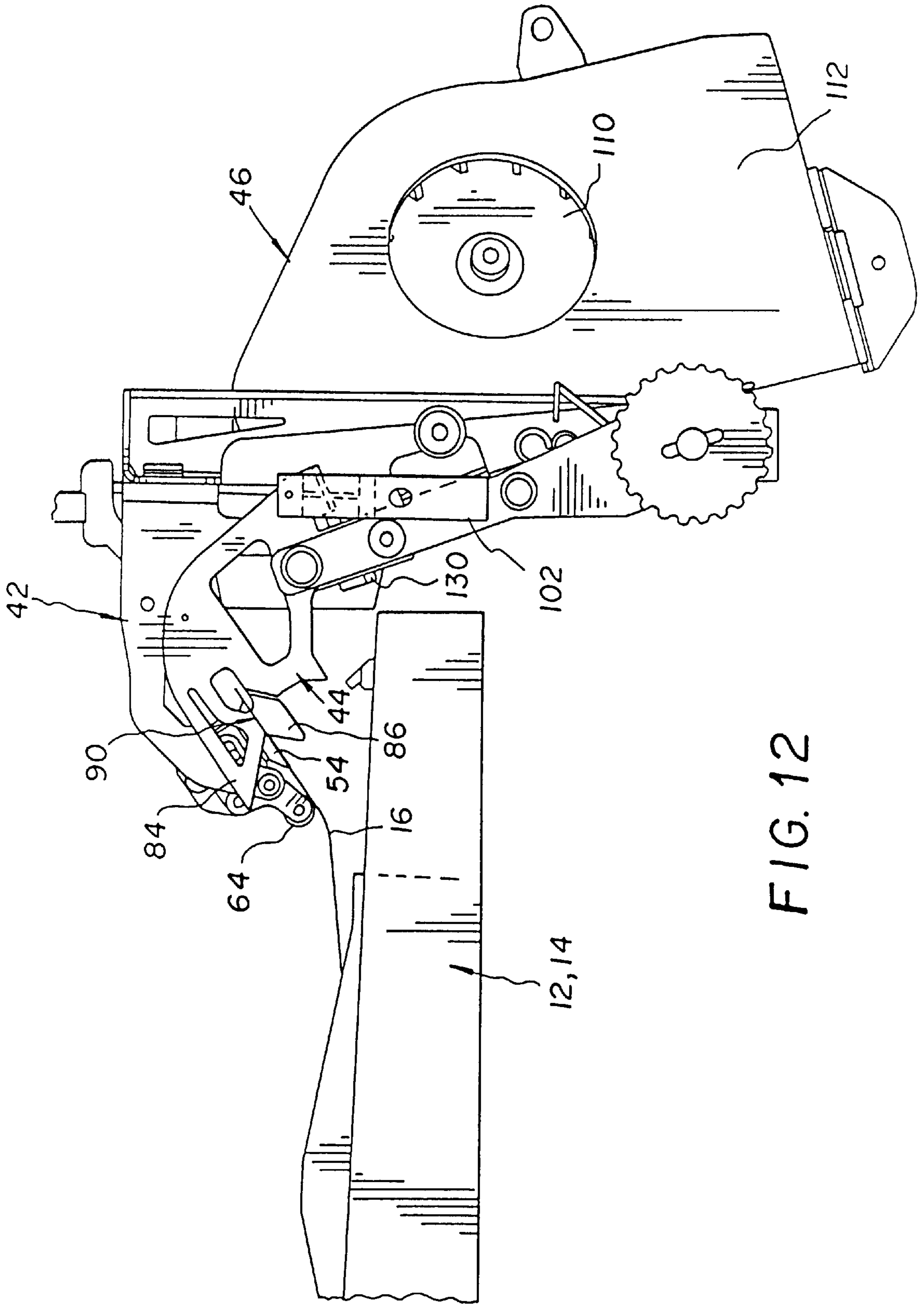

FIG. 12

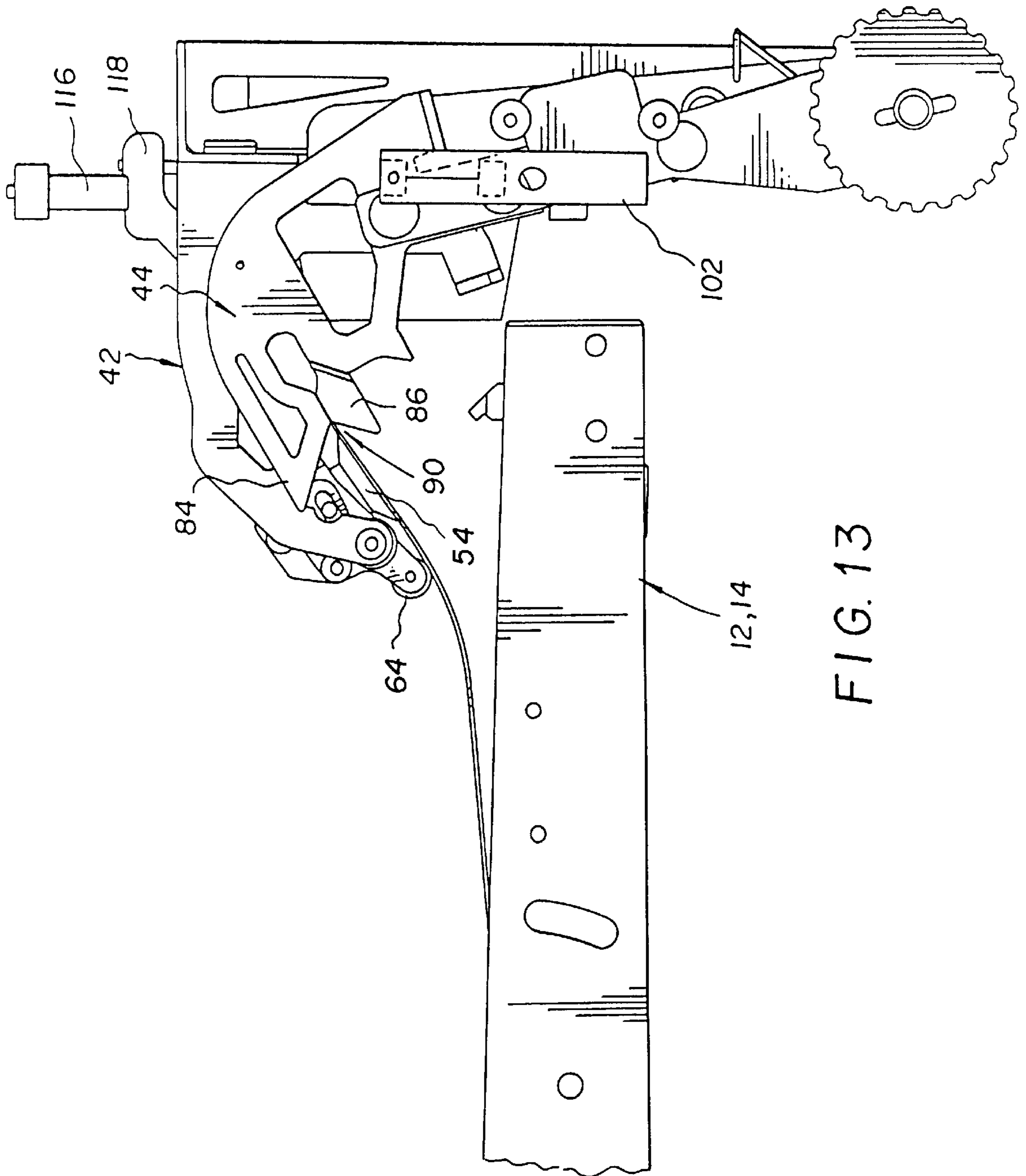

FIG. 13

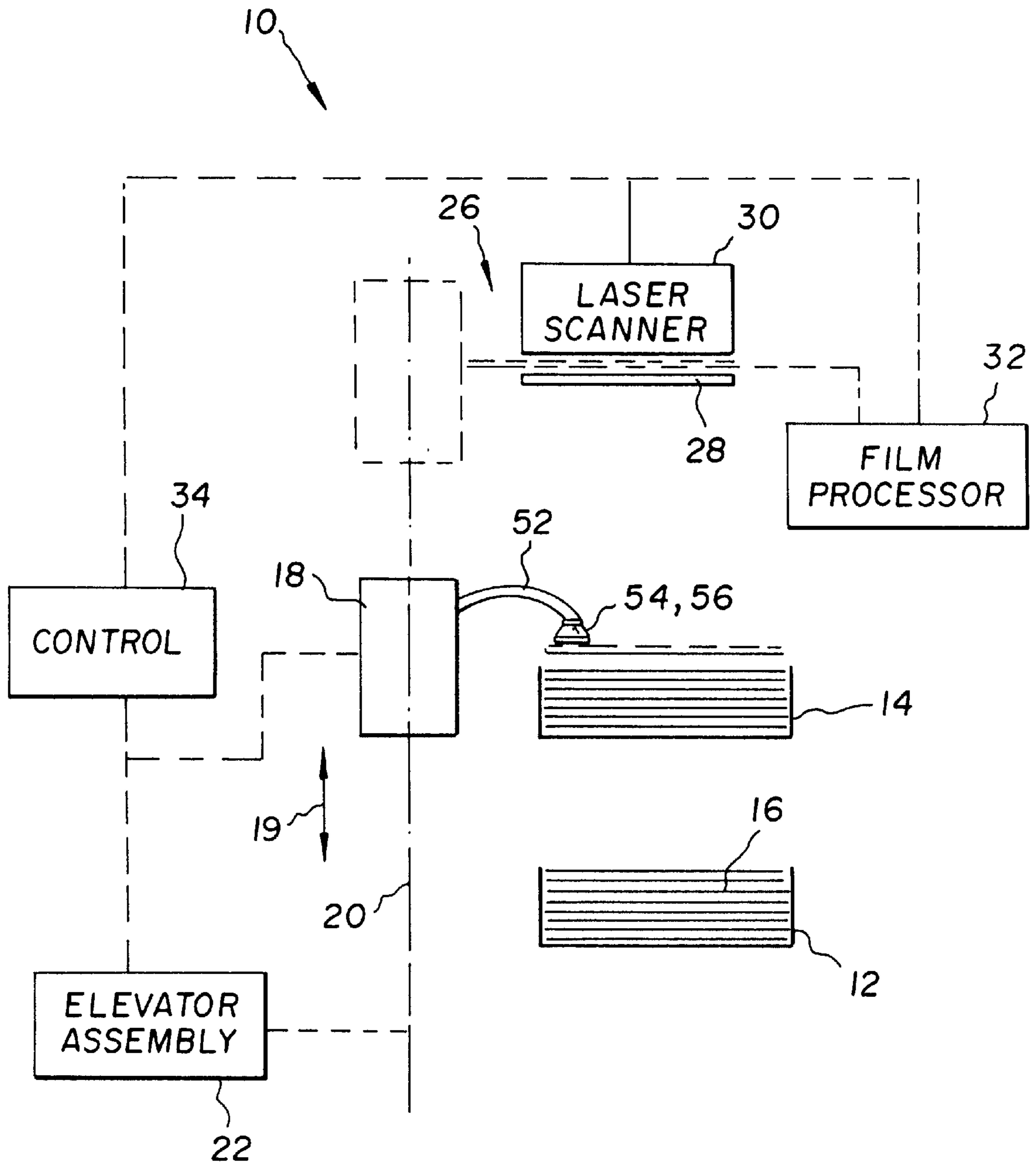

FIG. 14

## FILM SHEET PICKER ASSEMBLY

### FIELD OF THE INVENTION

This invention relates in general to film sheet handling and more particularly to a picker assembly for removing a film sheet from a stack of film sheets.

### BACKGROUND OF THE INVENTION

In radiographic laser printers, an unexposed radiographic film sheet is removed from a stack of film sheets and transported to an exposure station where it is exposed by a laser to a radiographic image. The unexposed film sheets are contained in a light tight magazine or cartridge which is opened when a film sheet is to be removed.

A known film sheet picker mechanism includes several vacuum cups mounted on a rigid manifold which is rotatably mounted at the end of a movable picker arm. A linkage driven by a standard electrical solenoid positions the vacuum cups in a manner that allows their perimeter to make full contact with the surface of the top film sheet. When the electrical power to the solenoid is removed a spring moves the vacuum cups in a manner that enhances the ability of the top sheet of film to separate itself from the sheet immediately below. The picker mechanism also incorporates a top of film detector designed to alert the mechanism's control system that the vacuum cups are near the top surface of the top film in a stack. Electrical conductors connect both the solenoid and detector to the support frame for the picker mechanism.

Such a picker assembly has several disadvantages.

1. The solenoid electrical conductors and the linkage connecting the solenoid to the vacuum cups frequently fail in a catastrophic manner which can result in a total machine shut down and an untimely and costly repair.
2. The solenoid, its linkage and associated electrical circuits are complex, expensive and unreliable.
3. The electrical wiring connecting the top of film sensor to the control electronics can fail due to abrasion and numerous flexures during normal operation. The consequent failure of the top of film detector can result in a destructive collision between the film picking mechanism and the top surface of the film.

There is thus a need for a film sheet picker mechanism which solves these problems.

### SUMMARY OF THE INVENTION

According to the present invention there is provided a solution to the problems discussed above.

According to a feature of the present invention there is provided a film sheet picker assembly comprising: a picker member which is movable into and out of proximity with the top film sheet of a stack of film sheets; a plurality of vacuum cups rotatably mounted on the picker member; means for biasing the plurality of vacuum cups at an angle relative to the top surface of the top film sheet; a roller assembly operatively associated with the plurality of vacuum cups; and a control for moving the picker member into proximity with the top film sheet of a stack of film sheets, such that the roller assembly contacts the top film sheet and rotates the plurality of vacuum cups into vacuum engagement with the top film sheet and for moving the picker member out of proximity with the stack of film sheets such that the biasing means rotates the vacuum cups to move the top film sheet out of contact with the stack of film sheets.

## ADVANTAGEOUS EFFECT OF THE INVENTION

The invention has the following advantages.

1. The elimination of the known solenoid, linkage, and connecting electrical wiring results in a robust design having long life and low repair cost.
2. The unit manufacturing cost and complexity is substantially reduced while eliminating several potential causes of failure.
3. Frequent failures caused by flexing electrical conductors connected to a sensor mounted to a rotating lever are eliminated.
4. Elimination of the top of film detector from the moving picker mechanism eliminates the possibility of failures to detect the presence of film due to broken wires that have fatigued during normal usage.

### BRIEF DESCRIPTION OF THE DRAWINGS

FIGS. 1 and 2 are perspective views of film sheet handling apparatus incorporating the present invention.

FIGS. 3-5 are perspective views of components of the apparatus of FIGS. 1 and 2.

FIGS. 6-13 are elevational, diagrammatic views useful in explaining the present invention.

FIG. 14 is a diagrammatic view of radiographic laser imaging apparatus incorporating the present invention.

### DETAILED DESCRIPTION OF THE INVENTION

Referring now to FIG. 14, there is shown radiographic laser imaging apparatus incorporating the present invention. As shown, radiographic laser imaging apparatus 10 includes film sheet supplies 12 and 14 containing stacks of unexposed radiographic film sheets 16. Supplies 12 and 14 can be light tight cartridges or magazines containing film sheets of the same or different sizes or the same or different film characteristics. An elevator and film sheet picker assembly 18 is driven in opposite vertical directions 19 on vertical guide 20 by elevator assembly 22. Assembly 18 includes a sheet picker 52 with suction cups 54. As will be described in more detail later, assembly 18 is driven to a supply 12,14, where picker 52 is rotated to bring suction cups 54 into contact with a top film sheet 16 for removal from the film sheet stack. After a single film sheet 16 has been removed, assembly 18 is driven to exposure station 26 where film sheet 16 is delivered to exposure platen 28. Laser scanner 30 exposes the unexposed film sheet to a radiographic image.

The exposed film sheet 16 is delivered to film processor 32 which processes the film sheet 16 to produce a developed radiographic film. Depending upon the type of film used, processor 32 can be either a wet or dry film processor.

Control 34 controls the operation of all of the components of apparatus 10, including elevator guide 20, elevator and picker assemblies 18,22, laser scanner 30, and film processor 32.

Referring now to FIGS. 1-5, there will be described in greater detail the film sheet picker assembly 18. As shown, assembly 18 includes a frame 40 which supports a film sheet picker assembly 42, a multiple sheet detector 44, and an air mover 46. Assembly 42 includes member 48, mounted at one end on shaft 50, and at the other end mounting U-shaped member 52. Member 52 has arms 53 supporting suction cups 54 by means of shaft 56 extending between arms 53, rocker member 58,60 mounted on shaft 56, plenum member 62



supporting cups **54** mounted on one side of rocker members **58,60** and rollers **64** mounted on shaft **66** on the other side of rocker members **58,60**. Suction cups **54** are supplied a vacuum by way of plenum member **62** and vacuum conduit **68**. Springs **69** bias cups **54** in a clockwise direction **57** (FIG. **5**) about shaft **56** to a position such that cups **54** are disposed at an angle to the surface of film sheets **16**.

A motor **78** mounted on frame **40** drives picker arm assembly **42** by means of belt **80** trained about sprocket **82** on shaft **50**.

Multiple sheet detector **44** is journaled on shaft **50** and includes jaws **84** and **86** mounted at the end of lever **88**. Jaws **84** and **86** have a space **90** between them which allows the passage of a single film sheet but which blocks the passage of more than one film sheet. The space has a dimension which is slightly greater than the thickness of one sheet of film but which is less than the thickness of two sheets of film. Detector **44** is biased in the direction of arrow **92** by spring **94**. Solenoid **96** with pin **98** holds detector **44** against the bias of spring **94**. Detector **44** has an interrupter member **100** which cooperates with photosensor **102** (see FIGS. **2**, **12**, and **13**) mounted on frame **40** to detect single or multiple sheets (as will be explained later).

Air mover **46** is fixedly mounted on frame **40** and includes a fan **110** (FIG. **12**) which moves air through chamber **112** out nozzle **114** to facilitate separation of a film sheet from its stack.

A top of film sensor **116** cooperates with linkage **118** on member **52** to indicate contact of the suction cups **54** with the top film sheet in a stack.

The operation of film sheet picker arm assembly **42**, multiple sheet detector **44**, and air mover **46** will now be described with particular reference to FIGS. **6-13**, but also with reference to the other figures.

As shown in FIG. **6**, the film sheet picker assembly **18** is moved by the elevator assembly **22** to a position relative to an open supply magazine **12,14** containing a stack of unexposed film sheets **16** that will allow the vacuum cups **54** to rotate into the magazine unobstructed.

As shown in FIG. **7**, picker arm assembly **42** including vacuum cups **54** is rotated into the selected supply magazine **12,14**. As rollers **64** engage the top film sheet, vacuum cups **54** are rotated into contact with the top film sheet.

The elevator assembly **22** then slowly lowers the entire picker assembly **18** until a top of film sheet photo sensor/linkage **116,118** indicates that the picker arm **52** is in proximity with the top film sheet **16** in the magazine **12,14**. Linkage **118** is rotated by rollers **64** and rocker members **58,60**.

As shown in FIG. **8**, upon sensing the presence of the top film sheet **16**, the elevator assembly **22** will continue to move downward a predetermined number of steps (this number is calibrated at machine assembly and is referred to as "press steps") that will bring the vacuum cups **54** into full contact with the top film sheet **16** through contact of rollers **64** with top film sheet **16**.

Upon completion of the press steps, the picker arm assembly **42** will utilize a vacuum switch (not shown) located within the picker assembly **18** to determine if the vacuum cups **54** have created an adequate seal with the top film sheet **16**. If the seal between the cups **54** and the film sheet **16** is not sufficiently to actuate the vacuum switch, the elevator assembly **22** will lower the picker assembly **18** an additional three elevator "steps" before checking the integrity of the seal again. This procedure will be repeated up to

six times before an error condition will be logged and displayed to the machine operator.

After the top film sheet **16** is secured to the vacuum cups **54**, the air mover **46** (FIGS. **4,5**) is signaled by the control **34** to change fan **110** from its low speed mode of operation to high speed to allow time for it to achieve maximum air flow in preparation for a film separation function that will to occur later in the picking cycle.

As shown in FIG. **9**, the picker arm assembly **42** is then moved slightly upward by elevator assembly **22** and the torque being applied by the picker arm motor **78** is decreased to allow the reaction forces in the picker assembly **42** to drive the edge of the top film sheet **16** into surface **120** film holdbacks **122** within the supply magazine **12,14**.

The picker assembly **42** is then moved higher to allow the surface **120** on the holdbacks **122** to aid separating the top film sheet **16** from the film sheet(s) **16** immediately below it.

As shown in FIG. **10**, the picker arm assembly **42** disengages the film sheet **16** from surface **120** as the vacuum cups **54** are rotated to a  $35^\circ$  angle relative to the top surface of the film stack through the bias effect of spring **69**.

With the front area of film sheet **16** positioned at  $35^\circ$  and being supported only by the vacuum cups **54**, the picker arm assembly **42** is held motionless for several seconds to allow gravity and the ambient air pressure to dislodge any film sheets **16** that may still be attached to the top film sheet **16**.

As shown in FIG. **11**, at the completion of this dwell time, the picker assembly **18** is moved to allow the air flow from the air mover **46** to completely separate the film sheet **16** being held by the vacuum cups **54** from the film sheet **16** immediately below it in the supply magazine **12,14**.

As shown in FIG. **12**, at the completion of the dwell, the picker assembly **42** is then move downwardly to a position to allow the multiple sheet detector **44** to function correctly.

Upon reaching this position, the detector **44** release solenoid **96** is activated and the detector **44** is allowed to rotate into the supply magazine **12,14**.

If the detector **44** encounters a single film sheet **16**, film sheet **16** will pass through space **90** between jaws **84,86**, and it will signal the control **34** (FIG. **14**) that the attempted pick was successful and the picker arm assembly **42** will pull the film sheet **16** attached to its vacuum cups **54** into the picker assembly **18** thus removing the film sheet **16** from the supply magazine **12,14**. Detector **44** will be stopped by stop **130** on assembly **42**. If, however, as shown in FIG. **13**, detector **44** indicates that more than one sheet **16** is being held by the vacuum cups **54** because the multiple sheets are stopped by jaws **84,86** since they fail to pass through space **90**. The control **34** will remove the vacuum from the cups **54** and allow the film sheets **16** to fall back into the supply magazine **12,14**. The control **34** will then begin a sequence of actions that is intended to insure that the fallen film sheets are located directly on top of the film stack and not resting on top of the film holdbacks **122**.

An indication of a multiple sheet pick will allow two additional attempts to be made to achieve a pick that has only one film sheet **16** held by the vacuum cups **54**. If the picker assembly is not capable of picking a single film sheet **16** from the stack after a total of three attempts, the control **34** will inform the operator of a machine malfunction and record the event in the machine's error log.

If a successful picking sequence occurred, it will be followed by the control **34** directing the elevator assembly **22** to move the picker assembly **18** upward until it is in a position that will allow the reverse rotation of the picker arm

## 5

assembly **42** to transfer film sheet **16** from the picker assembly **18** to the exposure platen **28** (FIG. 14).

After the film sheet **16** is resting on the platen **28**, the vacuum is removed from the vacuum cups **54** and the film sheet **16** is allowed to fall onto the platen **28**.

After the picker arm assembly **42** has returned to its "home" position, the elevator assembly **22** will lower the picker assembly **18** to a supply magazine **12,14** and the picking sequence can begin again.

The invention has been described in detail with particular reference to certain preferred embodiments thereof, but it will be understood that variations and modifications can be effected within the spirit and scope of the invention.

## PARTS LIST

10	imaging apparatus
12,14	supply magazine
16	film sheet
18	film sheet picker assembly
19	vertical directions
20	vertical guide
22	elevator assembly
24	sheet picker
26	suction cup
28	exposure platen
30	laser scanner
32	film processor
34	control
40	frame
42	film sheet picker arm assembly
44	multiple sheet detector
46	air mover
48	member
50	shaft
52	U-shaped member
53	arms
54	suction cups
56	shaft
57	clockwise direction
58,60	rocker members
62	plenum member
64	rollers
66	shaft
68	vacuum conduit
69	springs
78	motor
80	belt
82	sprocket
84,86	jaws
88	lever
90	space

## 6

-continued

## PARTS LIST

92	arrow
94	spring
96	solenoid
98	pin
100	interrupter member
102	photosensor
110	fan
112	chamber
114	nozzle
116	film sensor
118	linkage
120	surface
122	film holdbacks

What is claimed is:

**1.** A film sheet picker assembly comprising:

a picker member which is movable into and out of proximity with the top film sheet of a stack of film sheets;

a plurality of vacuum cups rotatably mounted on said picker member;

means for biasing said plurality of vacuum cups at an oblique angle relative to the top surface of said top film sheet;

a roller assembly operatively associated with said plurality of vacuum cups; and

a control for moving said picker member into proximity with the top film sheet of said stack of film sheets, such that said roller assembly contacts said top film sheet and rotates said plurality of vacuum cups into vacuum engagement with said top film sheet and for moving said picker member out of proximity with said stack of film sheets such that said biasing means rotates said vacuum cups to move said top film sheet out of contact with said stack of film sheets.

**2.** The assembly of claim **1** wherein said plurality of vacuum cups and said roller assembly are mounted on opposite ends of a rocker member structure that is rotatably mounted on said picker member.

**3.** The assembly of claim **1** including a top of film sensor mounted on said picker member for sensing engagement of said plurality of vacuum cups with said top film sheet.

\* \* \* \* \*