



US005946097A

United States Patent [19]

[11] Patent Number: **5,946,097**

Sanders et al.

[45] Date of Patent: **Aug. 31, 1999**

[54] VIBRATION RECTIFICATION ERROR REDUCER FOR FIBER OPTIC GYROSCOPE

[75] Inventors: **Glen A. Sanders**, Scottsdale; **Rudolf C. Dankwort**; **Ralph A. Bergh**, both of Phoenix, all of Ariz.

[73] Assignee: **Honeywell Inc.**, Minneapolis, Minn.

[21] Appl. No.: **09/001,967**

[22] Filed: **Dec. 31, 1997**

[51] Int. Cl.⁶ **G01C 19/72**

[52] U.S. Cl. **356/350**

[58] Field of Search **356/350, 345**

[56] References Cited

U.S. PATENT DOCUMENTS

5,278,631	1/1994	Hollinger et al.	356/350
5,351,123	9/1994	Spahlinger	356/350
5,469,257	11/1995	Blake et al.	356/350

OTHER PUBLICATIONS

Aritaka Ohno, Shinji Motohara, Ryuji Usui, Yuji Itoh and Kenichi Okada, "Development of Fiber-Optic-Gyroscope with Environmental Ruggedness", SPIE vol. 1585 Fiber Optic Gyros: 15th Anniversary Conference (1991).

Primary Examiner—Samuel A. Turner
Attorney, Agent, or Firm—Albert K. Kau

[57] ABSTRACT

An apparatus for eliminating or reducing vibration-induced errors due to vibration rectification by applying a variable weighting function at the demodulator or analog-to-digital converter by changing the size of the demodulator reference signal or the converter gain, respectively. The changing is performed within the frequency spectrum of the vibration. Sampling of the detector output may be utilized and the samples are accumulated and processed to remove the variations due to vibration, and the rotation rate is recovered by digital demodulation.

19 Claims, 14 Drawing Sheets

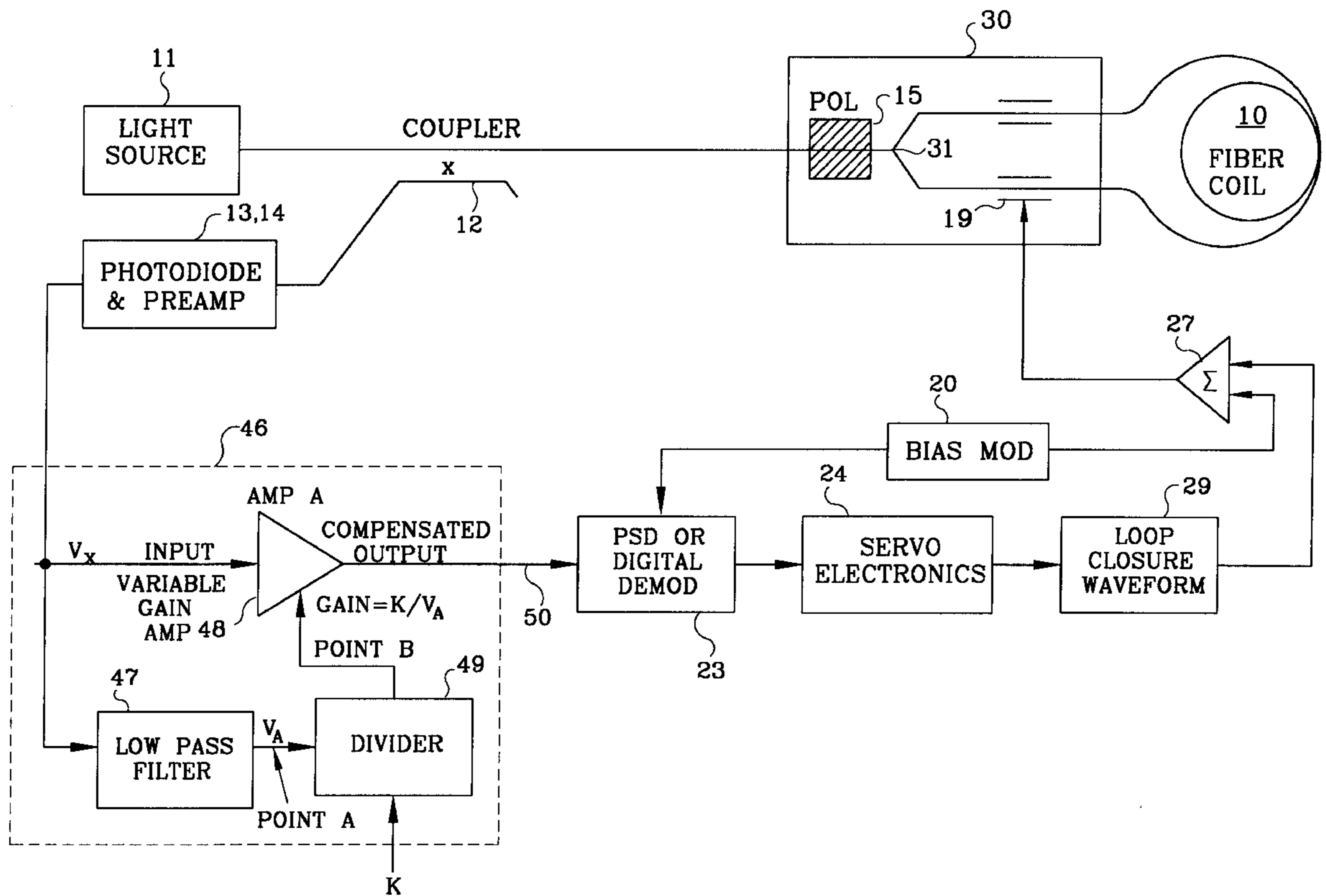

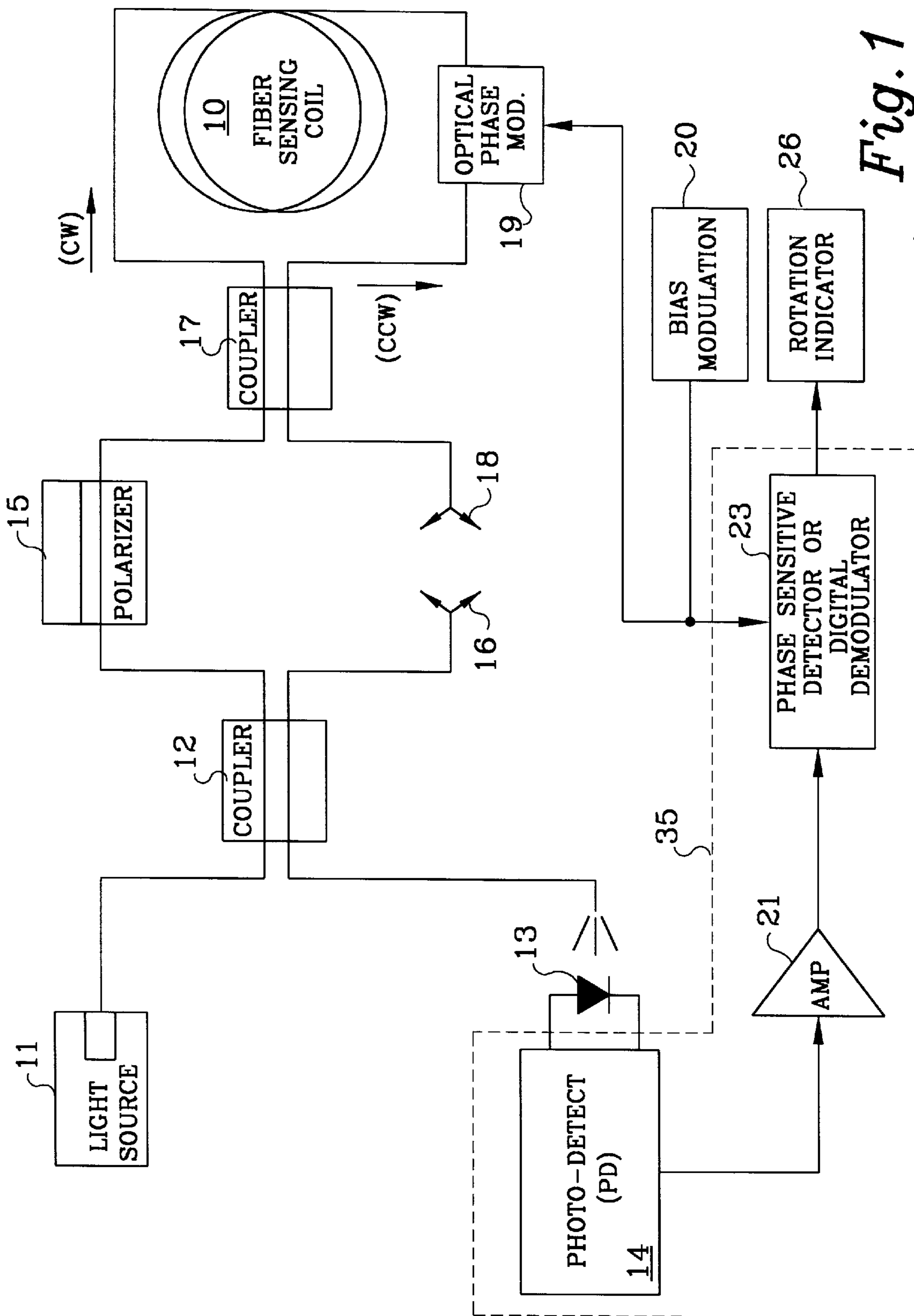

Fig. 1
(PRIOR ART)

DETECTED OPTICAL INTENSITY
OR DETECTOR OUTPUT CURRENT

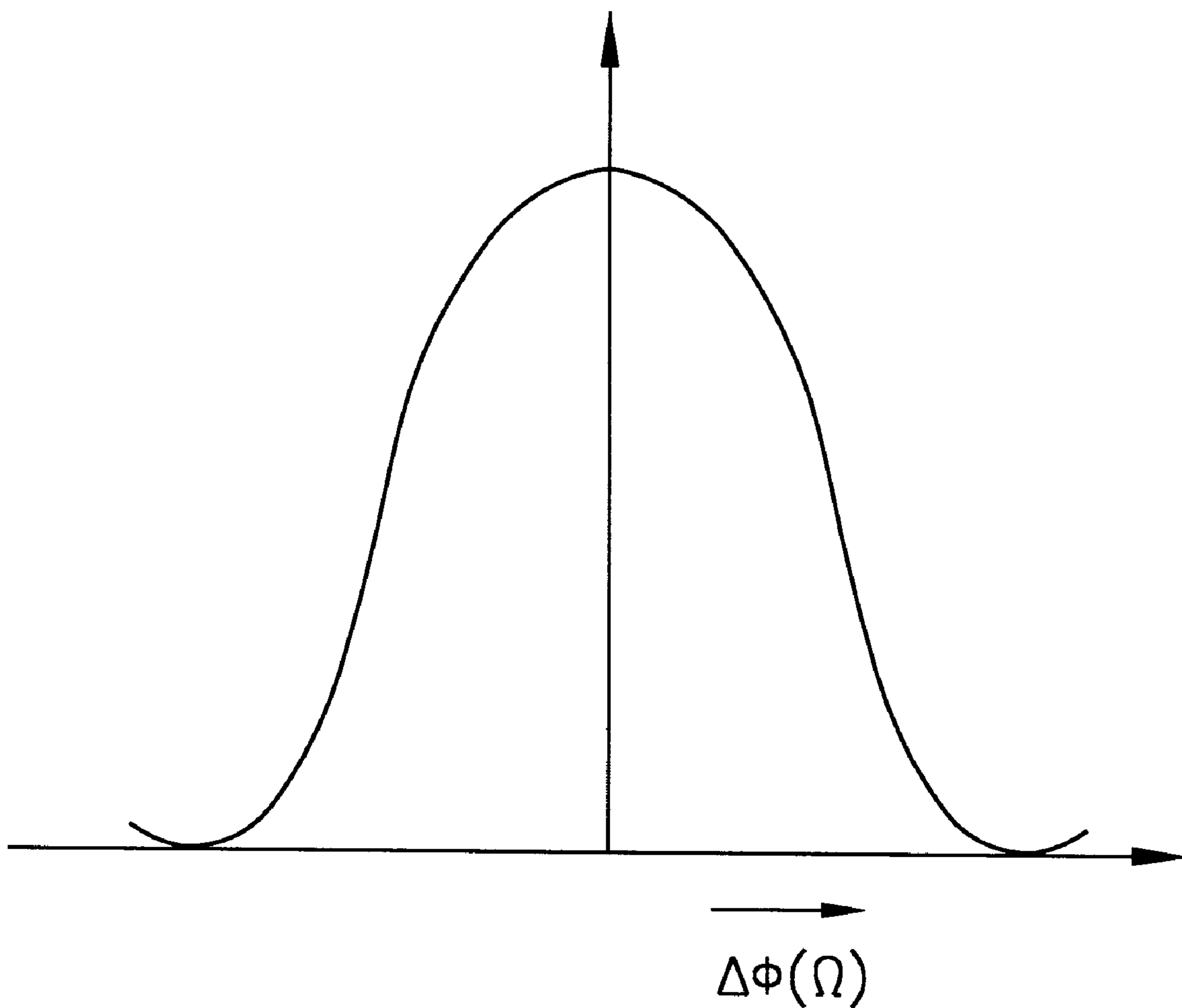
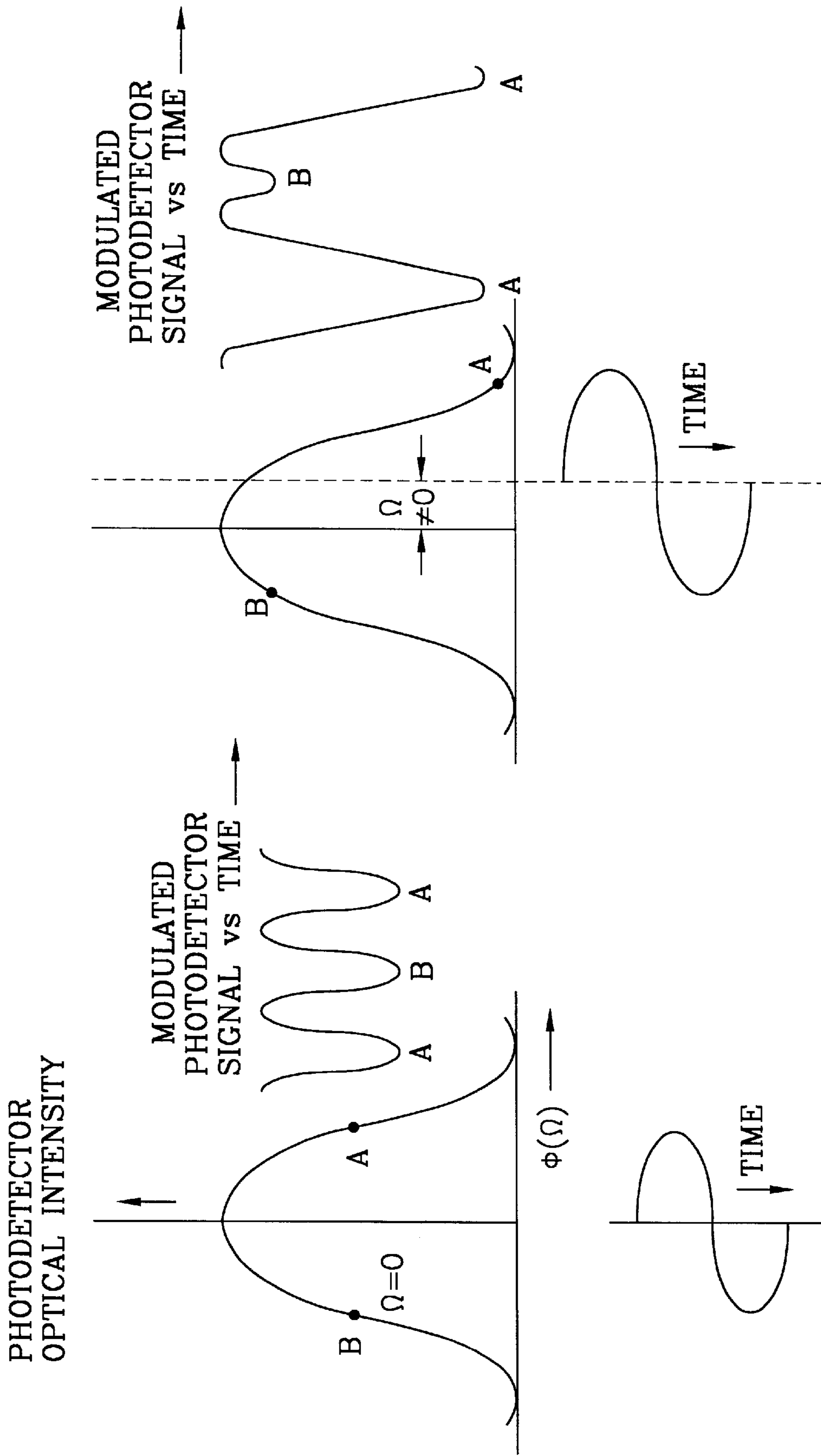

Fig. 2



APPLIED BIAS PHASE MODULATION AT f_b *Fig. 3b*

APPLIED BIAS PHASE MODULATION AT f_b *Fig. 3a*

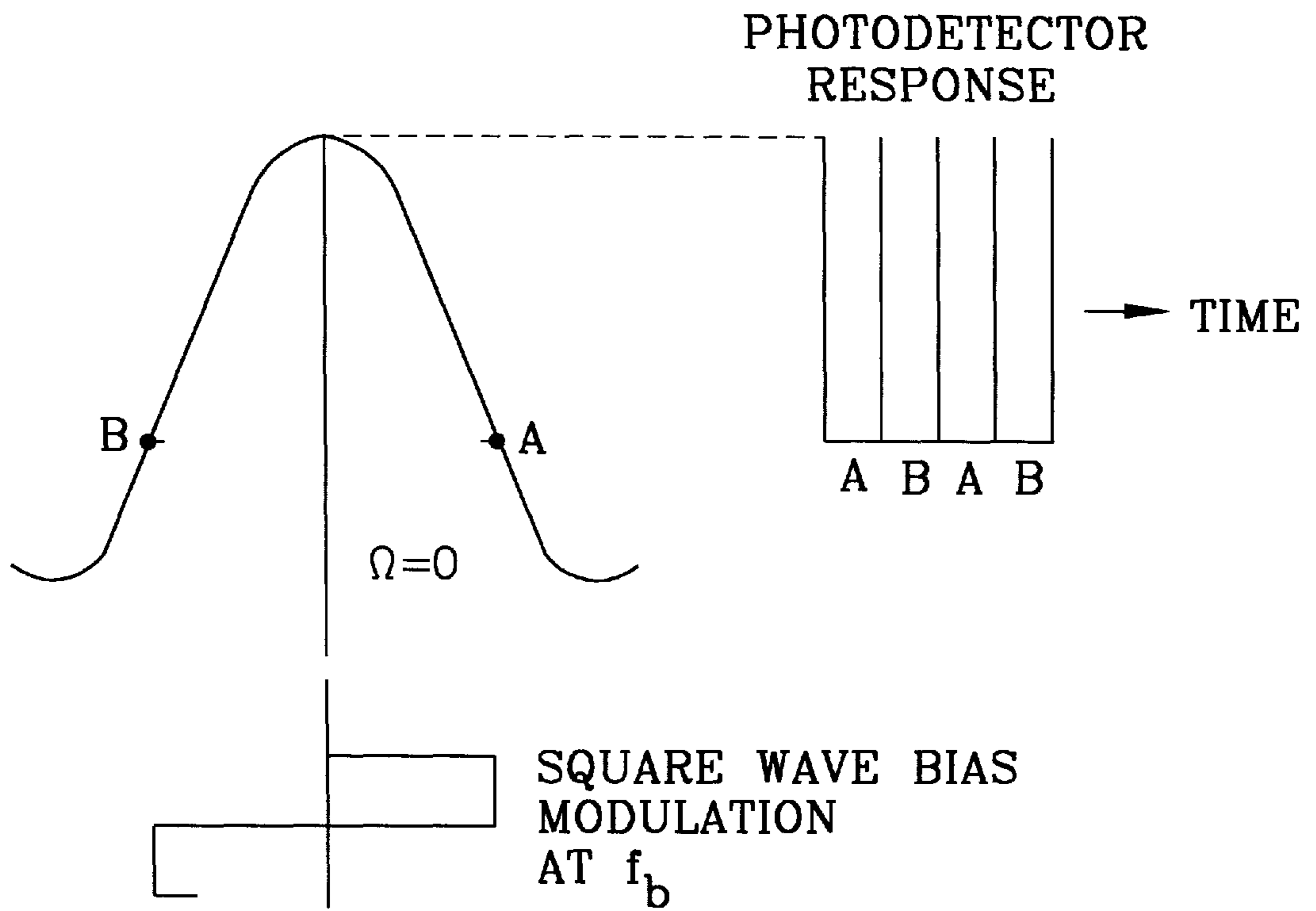

Fig. 4a

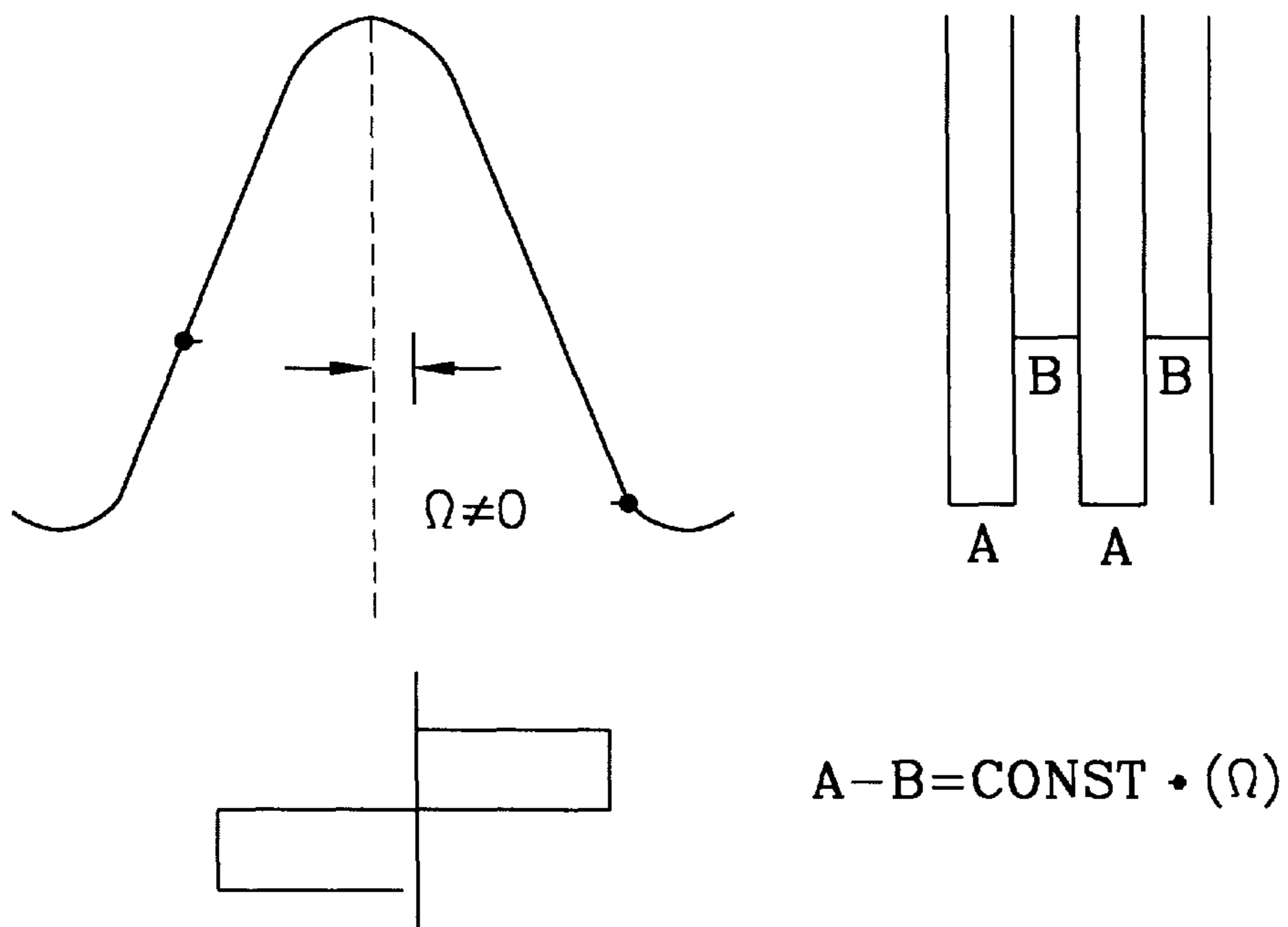

Fig. 4b

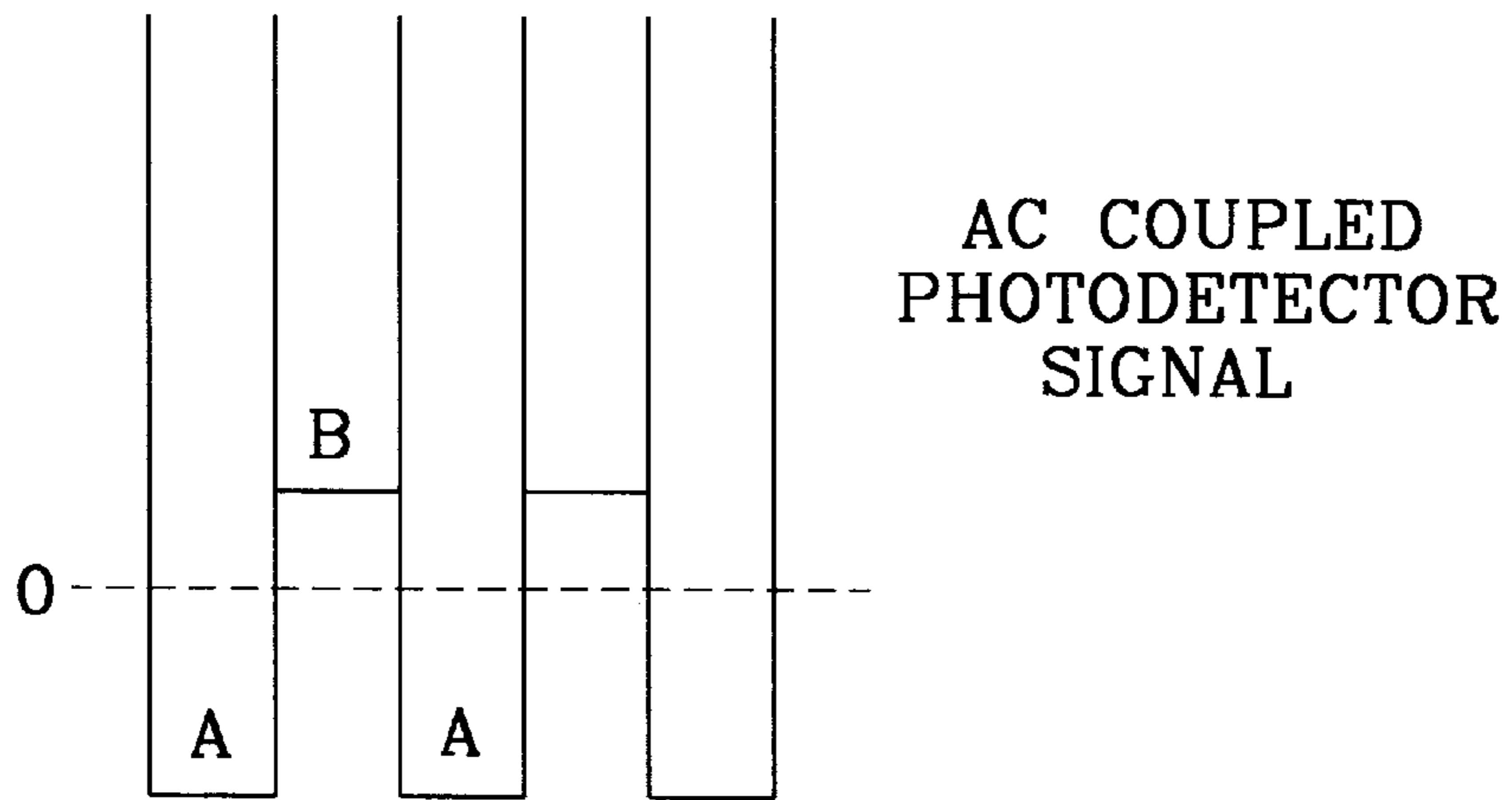

Fig. 5a

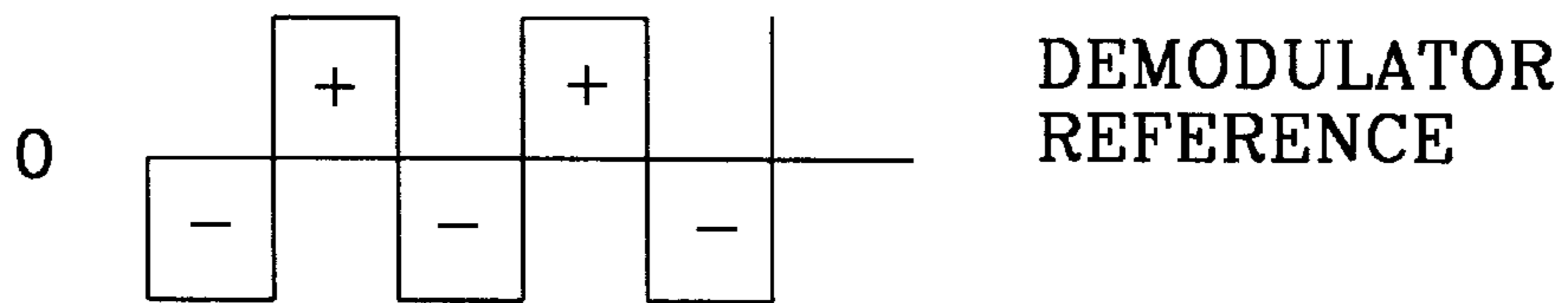

Fig. 5b

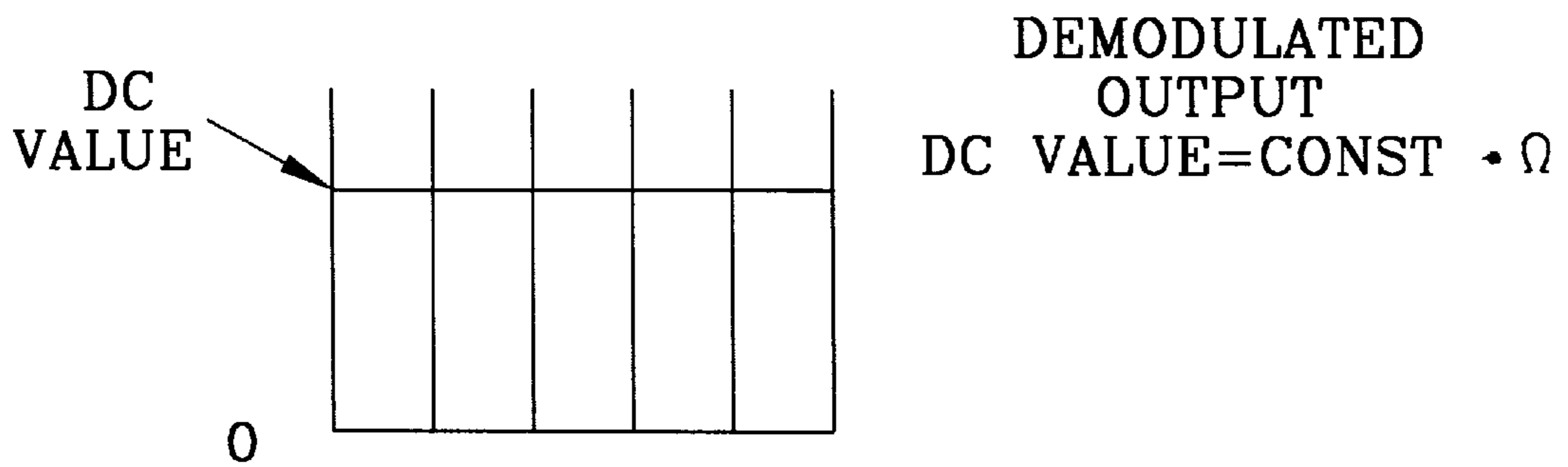
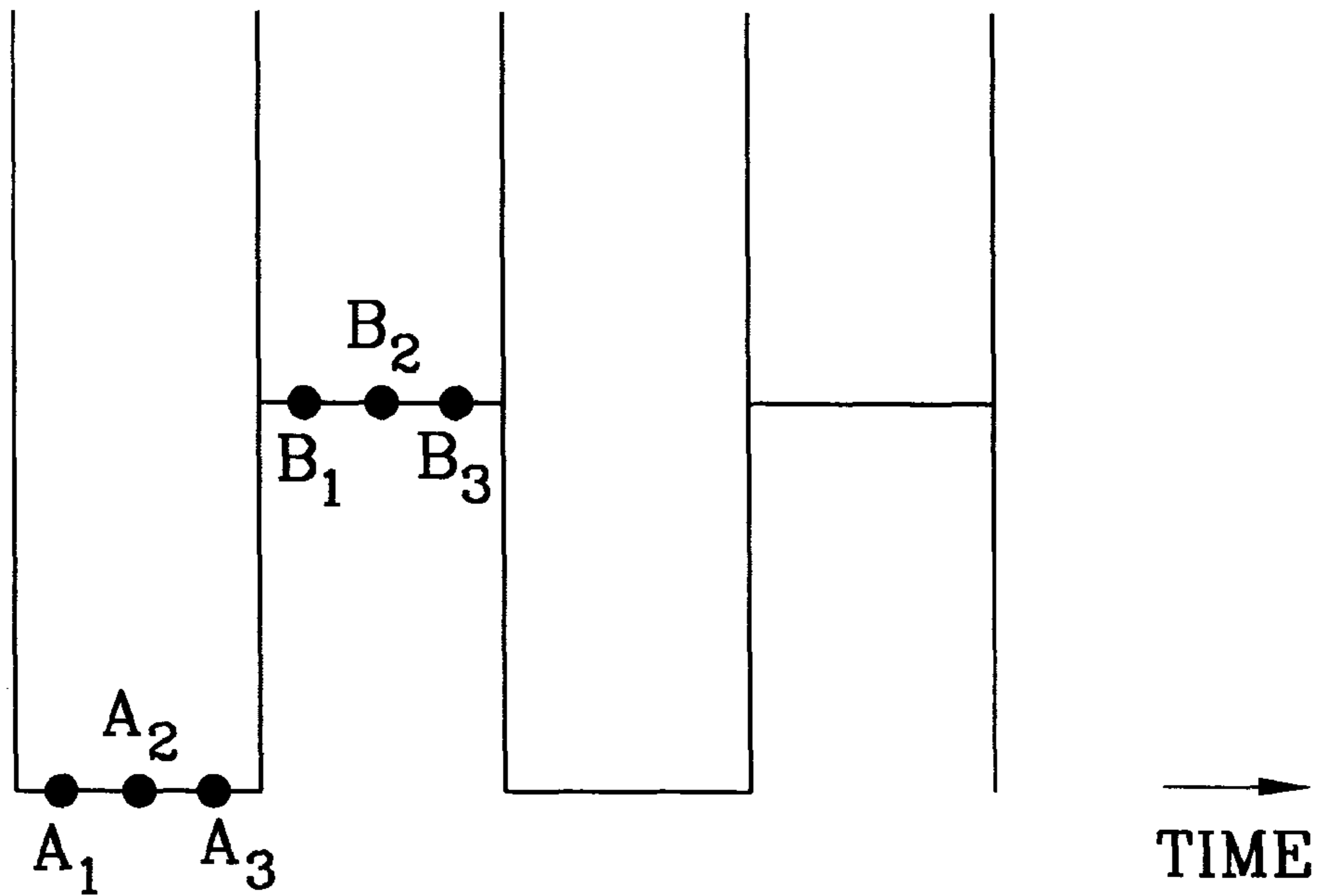

Fig. 5c

MODULATED
PHOTODETECTOR OUTPUT



SAMPLED SYSTEM
A_i, B_i ARE DIGITAL
NUMBERS

$$\sum_i (A_i - B_i) = \text{CONST} \cdot \Omega$$

Fig. 6

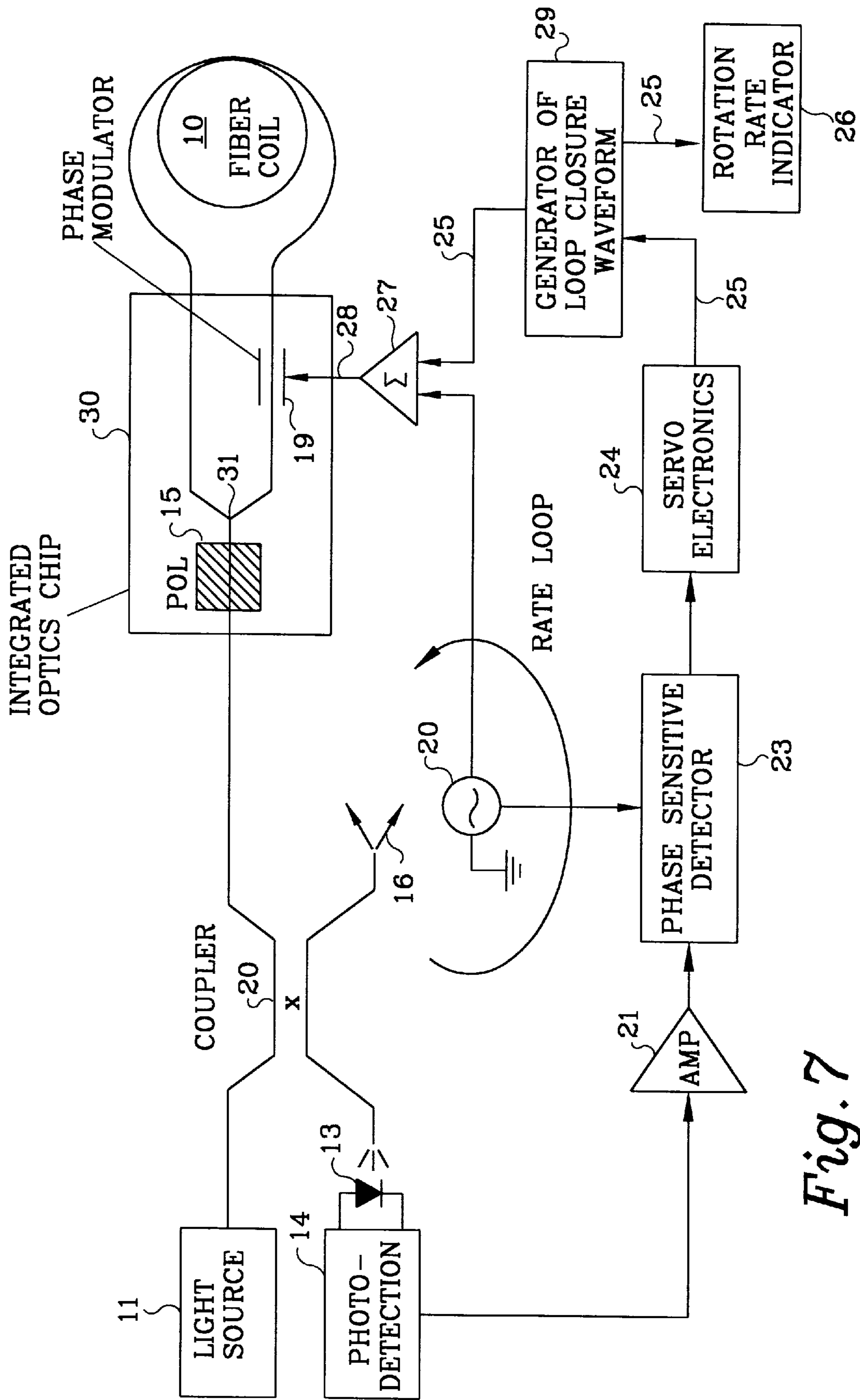

Fig. 7
(PRIOR ART)

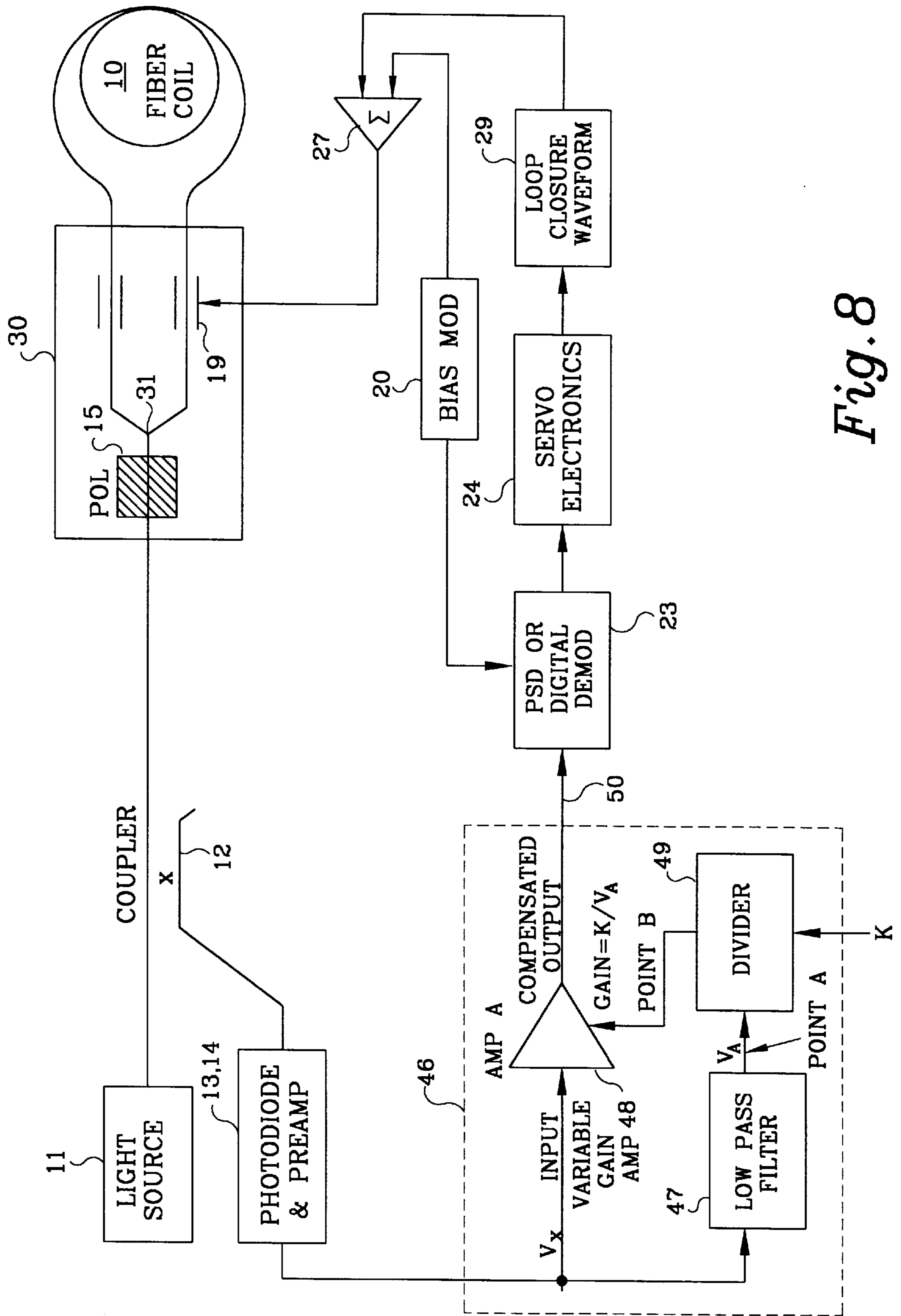

Fig. 8

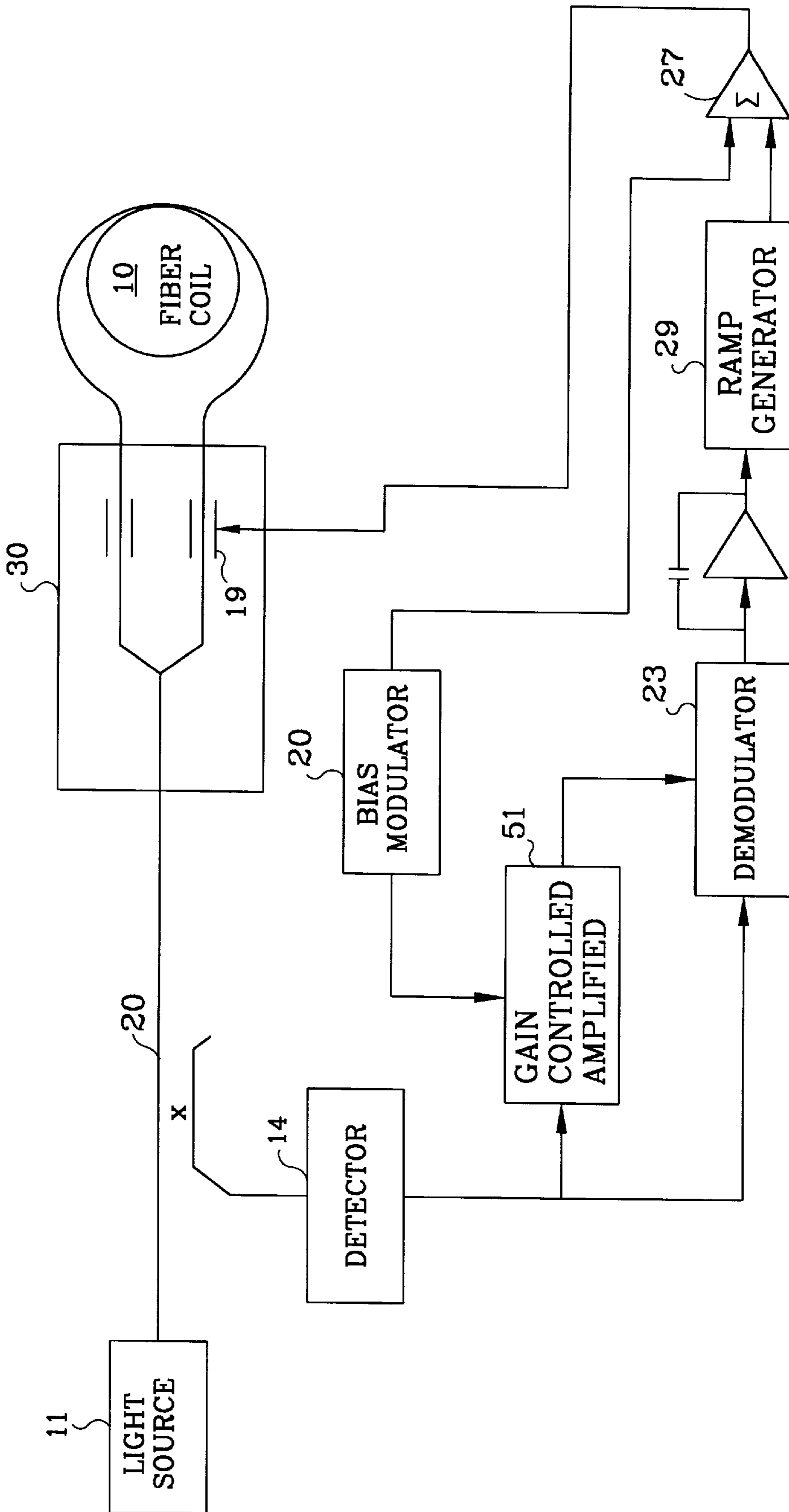

Fig. 9

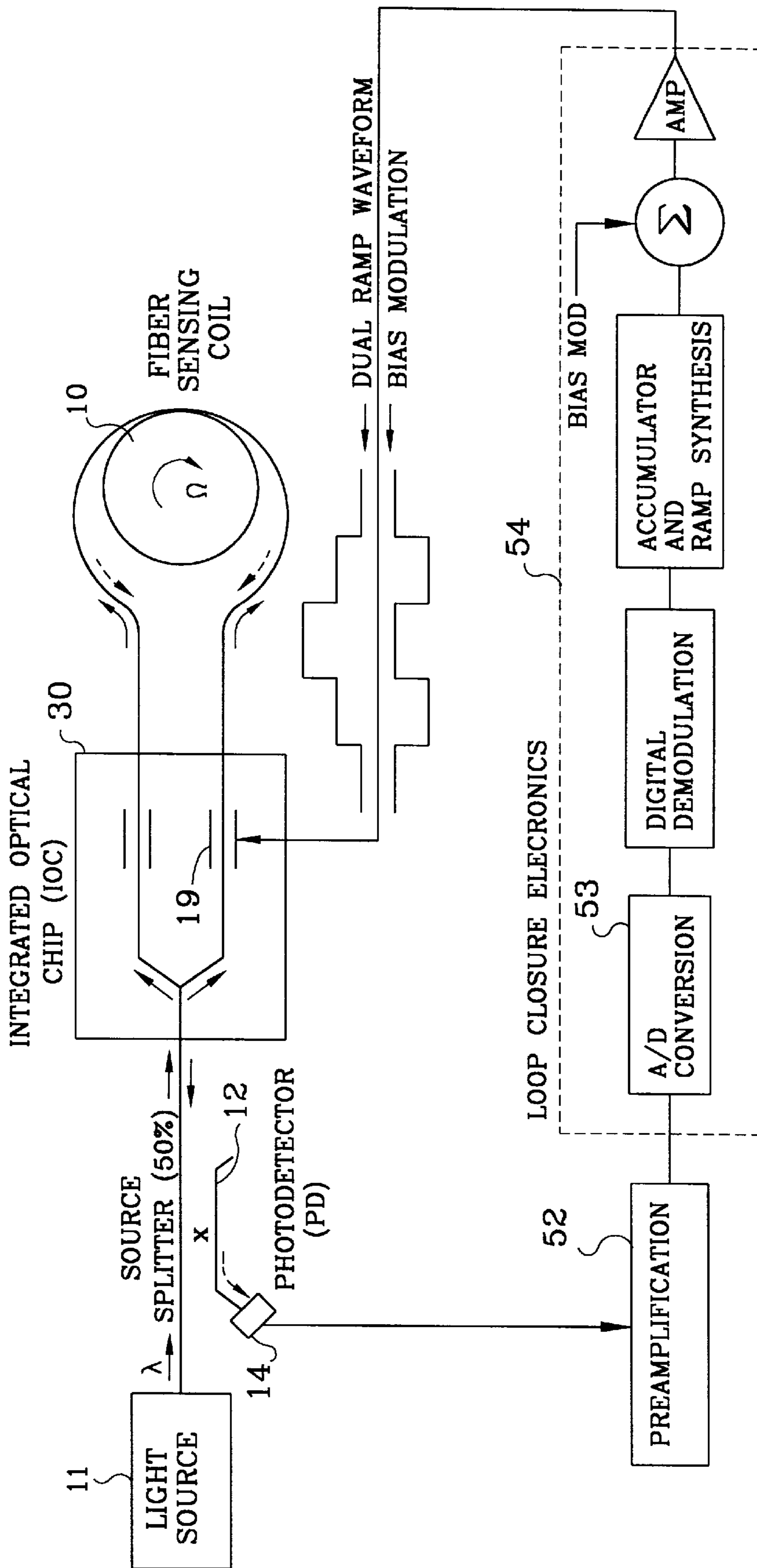

Fig. 10a
(PRIOR ART)

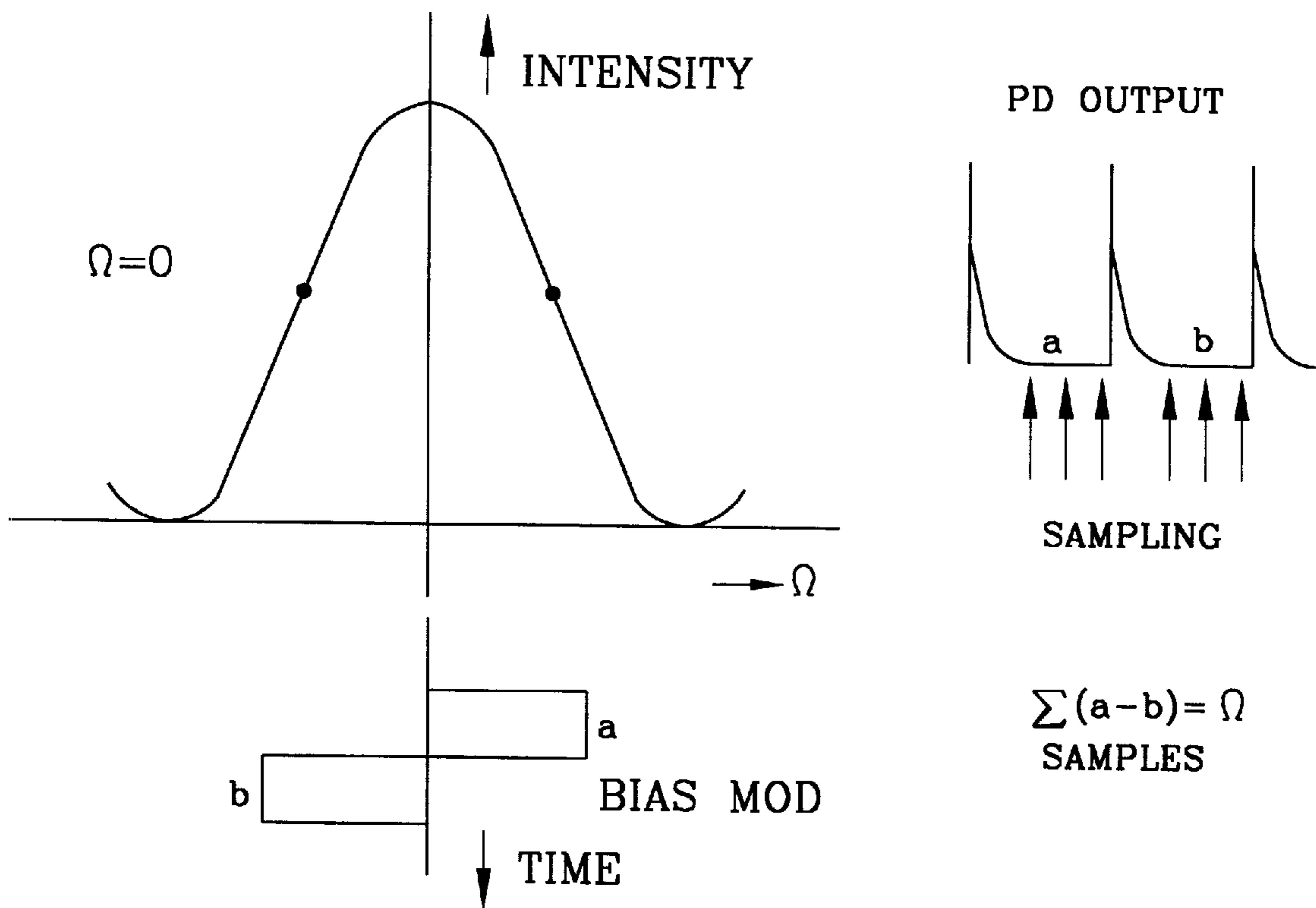

Fig. 10b

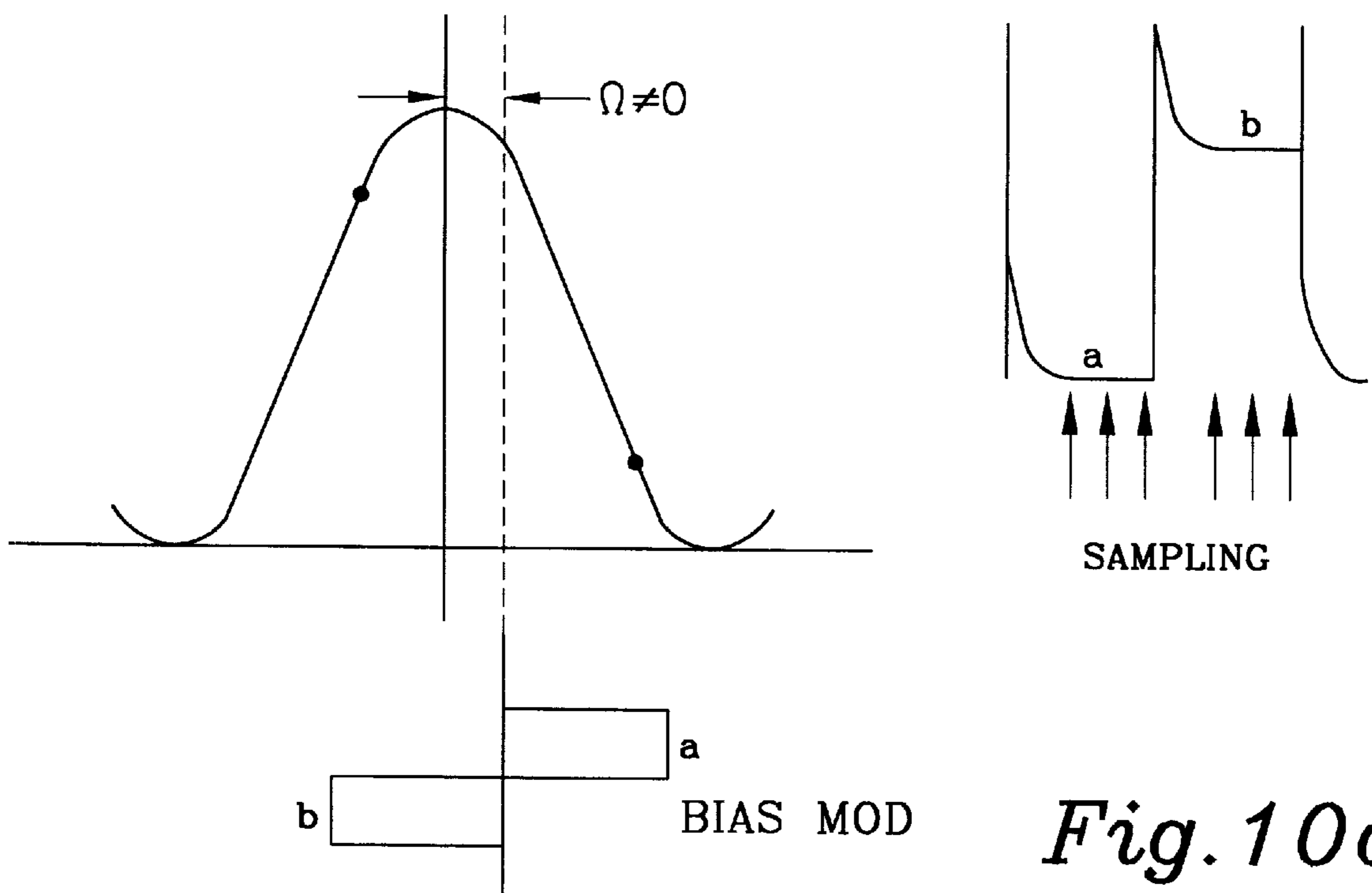

Fig. 10c

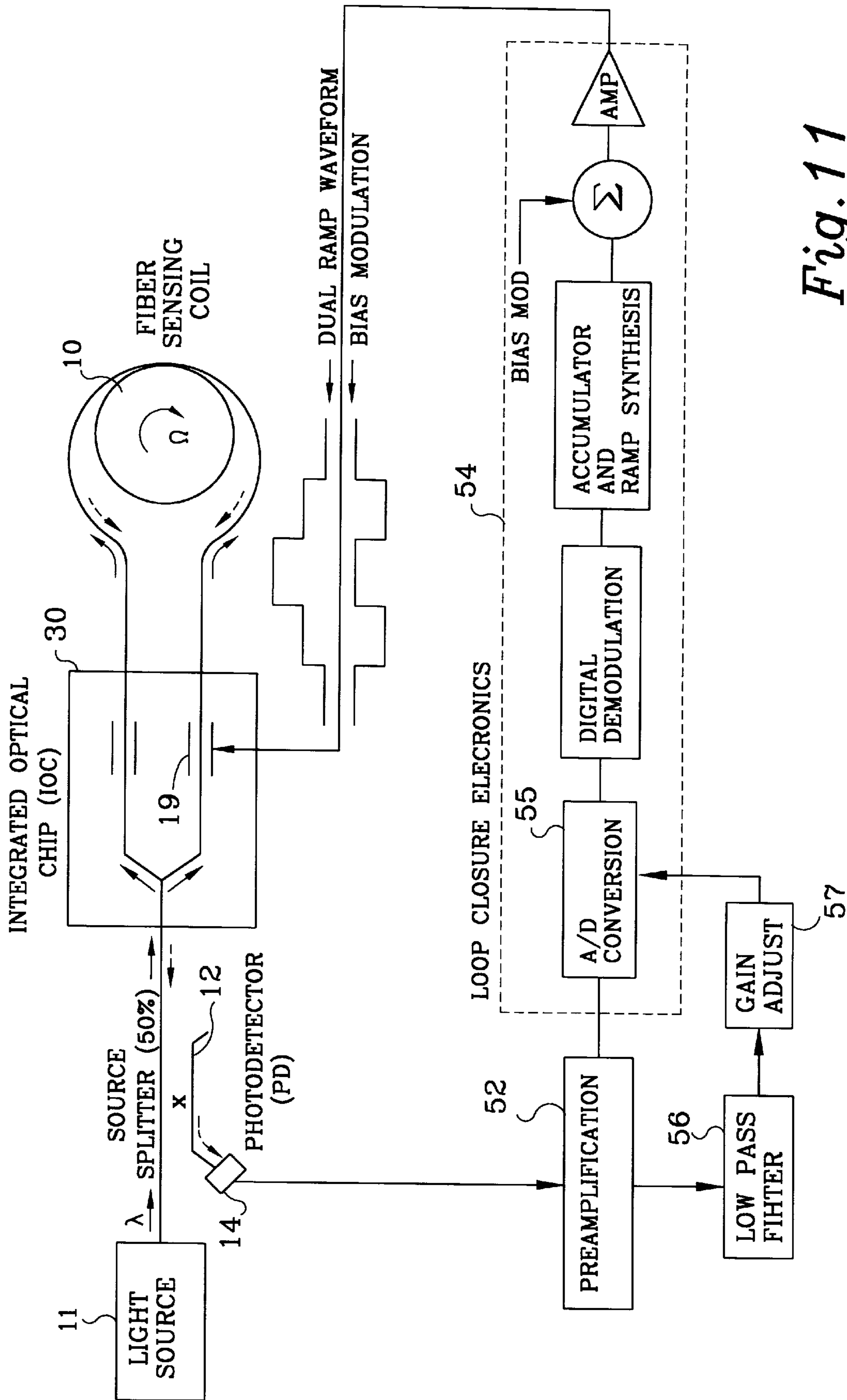

Fig. 11

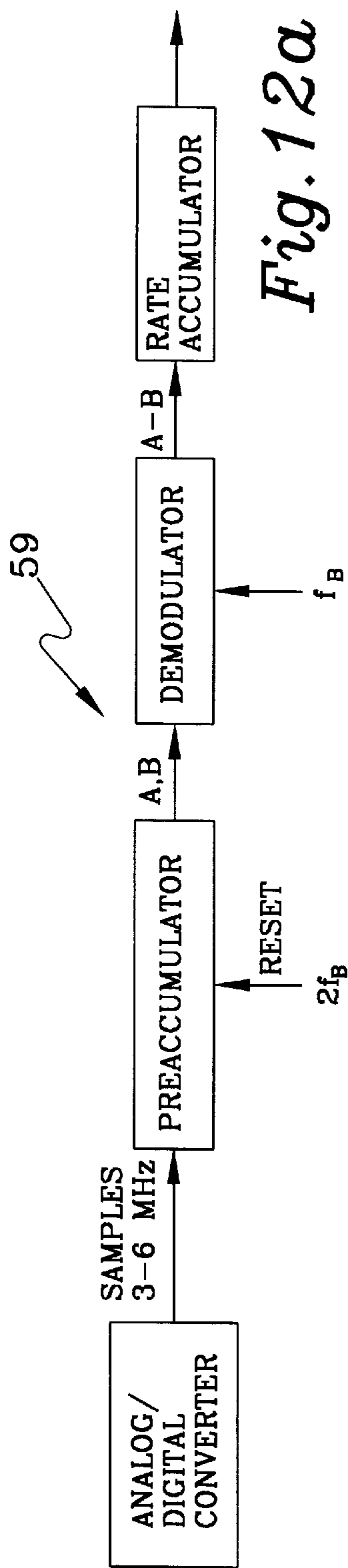

Fig. 12a
(PRIOR ART)

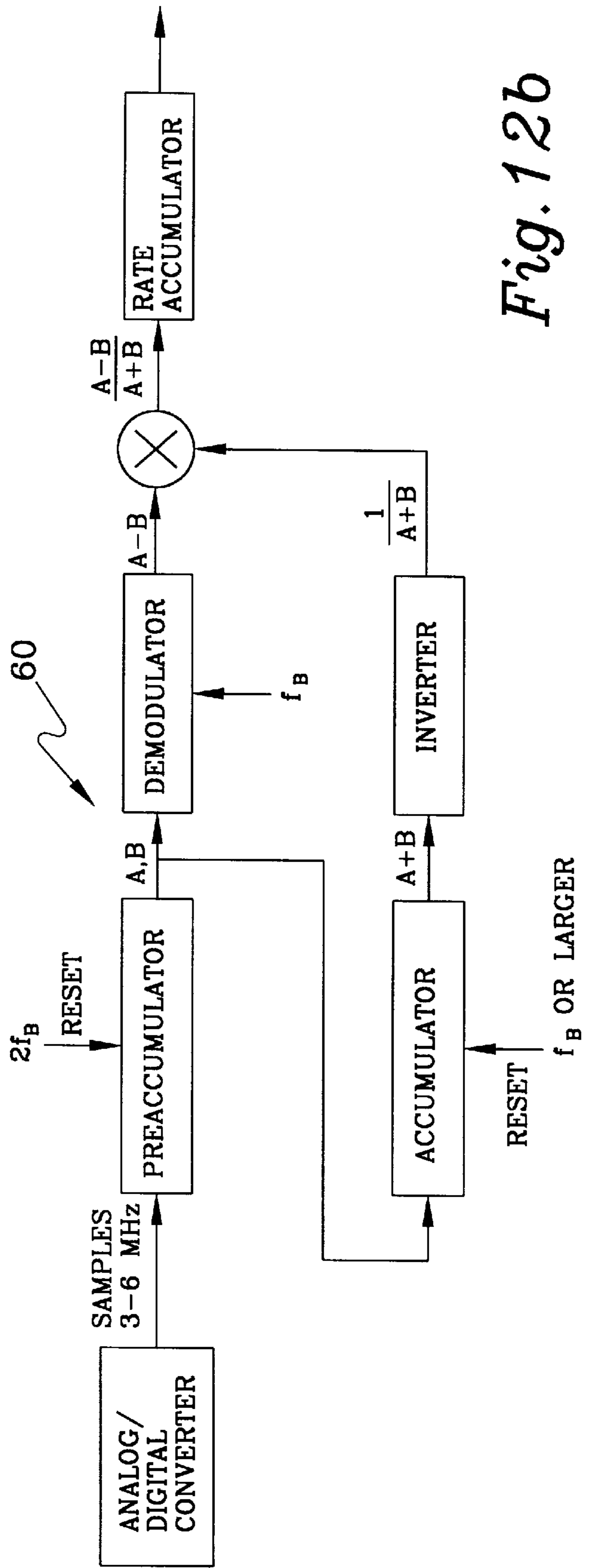

Fig. 12b

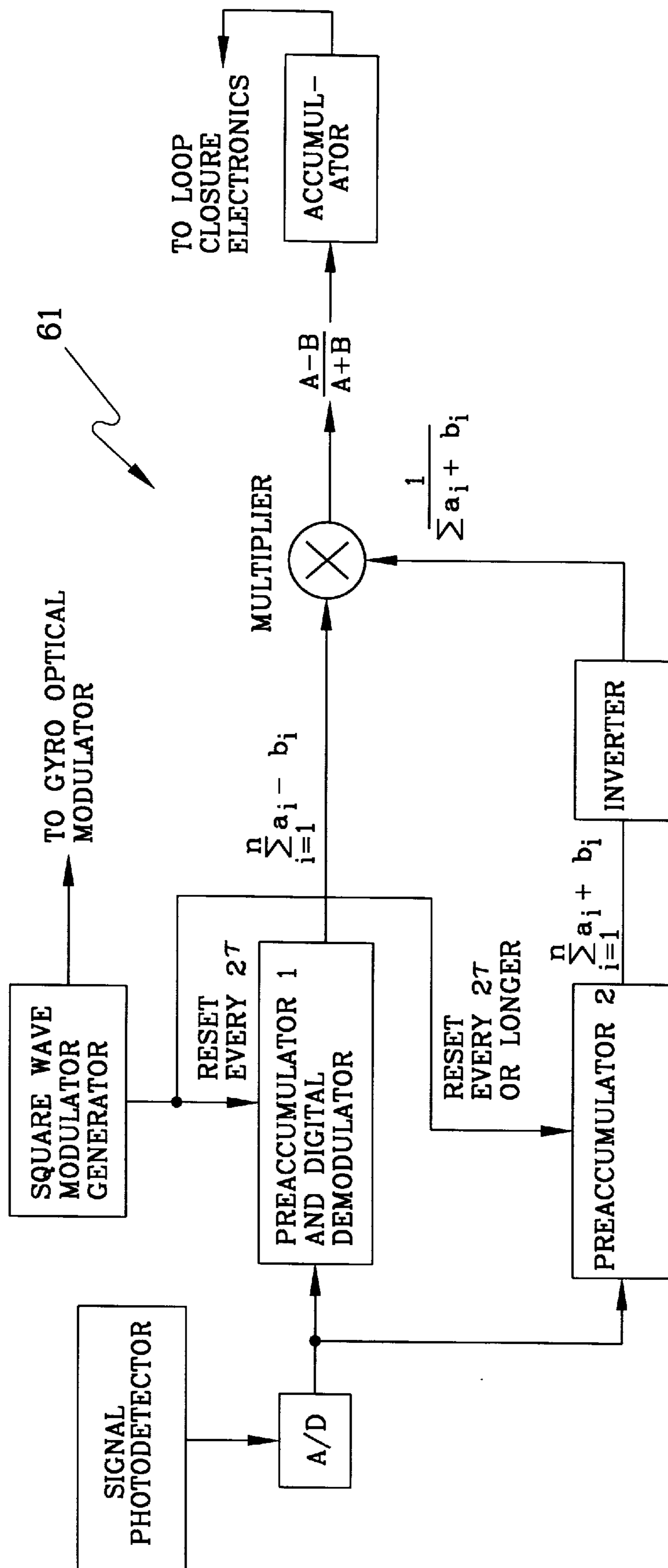

Fig. 13

VIBRATION RECTIFICATION ERROR REDUCER FOR FIBER OPTIC GYROSCOPE

BACKGROUND

The present invention concerns fiber optic gyroscopes having vibration-error reduction schemes, and more particularly alleviating false indications of rotation rate due to rectification of vibration at vibration frequencies in the gyroscope operating environment.

Fiber optic gyroscopes are an attractive means with which to sense rotation of an object supporting such a gyroscope. Such gyroscopes can be made quite small and can be constructed to withstand considerable mechanical shock, temperature change, and other environmental extremes. Due to the absence of moving parts, they can be nearly maintenance free, and they have the potential of becoming economical in cost. They can also be sensitive to low rotation rates that can be a problem in other kinds of optical gyroscopes.

A fiber optic gyroscope, as shown in FIG. 1, has a coiled optical fiber wound on a core and about the axis thereof around which rotation is to be sensed. The optical fiber is typical of a length of 50 to 2,000 meters, or so, and is part of a closed optical path in which an electromagnetic wave, or light wave, is introduced and split into a pair of such waves to propagate in clockwise (cw) and counterclockwise (ccw) directions through the coil to both ultimately impinge on a photodetector. Rotation Ω about the sensing axis of the core, or the coiled optical fiber, provides an effective optical path length increase in one rotational direction and an optical path length decrease in the other rotational direction for one of these waves. The opposite result occurs for rotation in the other direction. Such path length differences between the waves introduce a phase shift between these waves for either rotation direction, i.e., the well-known Sagnac effect. This gyroscope is known as the interferometric fiber optic gyro (IFOG). The use of a coiled optical fiber is desirable because the amount of phase difference shift due to rotation, and so the output signal, depends on the length of the entire optical path through the coil traversed by the two electromagnetic waves traveling in opposed direction, and so a large phase difference can be obtained in the long optical fiber but in the relatively small volume taken by it as a result of being coiled.

The output light intensity impinging on the photodetector and hence the current emanating from the photodetector system photodiode (PD), in response to the opposite direction traveling electromagnetic waves impinging thereon after passing through the coiled optical fiber, follows a raised cosine function. That is, the output current depends on the cosine of the phase difference $\phi(\Omega)$ between these two waves as shown in FIG. 2. Since a cosine function is an even function, such an output function gives no indication as to the relative directions of the phase difference shift, and so no indication as to the direction of the rotation about the coil axis. In addition, the rate of change of a cosine function near zero phase is very small, and so such an output function provides very low sensitivity for low rotation rates.

Because of these unsatisfactory characteristics, the phase difference between the two opposite direction traveling electromagnetic waves is usually modulated by placing an optical phase modulator, or what is sometimes referred to as a bias modulator, in the optical path on one side of or adjacent to one side of the coiled optical fiber. In order to achieve sensitive detection of rotation, the Sagnac interferometer is typically biased at a frequency f_b by a sinusoidal

or square wave modulation of the differential phase between the counter-propagating beams within the interferometric loop. As a result, one of these oppositely directed propagating waves passes through the modulator on the way into the coil while the other wave, traversing the coil in the opposite direction, passes through the modulator upon exiting the coil.

In addition, a phase-sensitive detector PSD serving as part of a demodulator system or a digital demodulator is provided to receive a signal representing the photodetector output current. Both the phase modulator and the phase-sensitive detector can be operated by the modulation signal generator or a synchronized derivative thereof at the so-called "proper" frequency to reduce or eliminate modulator induced amplitude modulation.

FIGS. 3a, 3b, 4a and 4b show the effect of modulation and demodulation over the raised cosine function. In FIGS. 3a and 3b, the phase difference $\Delta\phi$ of the gyro optical waves are modulated with a sine wave bias modulation for the cases of $\Omega=0$ and $\Omega\neq 0$ respectively. The resulting modulated intensity output of the photodetector vs time is shown to the right of the raised cosine function. As FIGS. 3a and 3b show, for $\Omega=0$ the phase modulation is applied symmetrically about the center of the raised cosine function and for $\Omega\neq 0$ the phase modulation is applied asymmetrically. In the first case, the output is the same when the sensor is biased at point A as when it is biased at point B, giving only even harmonics of f_b on the photodetector output. In the second case, the outputs at A and B are unequal, giving significant photodetector signal content at f_b , which is indicative of rotation rate. This signal content at f_b , recovered by the phase sensitive demodulator (PSD), is proportional to the rotation rate Ω . The signal also changes sign for an oppositely directed rotation rate.

FIGS. 4a and 4b show the case of square wave modulation for $\Omega=0$ and $\Omega\neq 0$, respectively. Here, in practice, square wave modulation produces a modulation transient by the value of switching $\Delta\phi$ from point A to point B on the raised cosine function. These are shown by the vertical lines in the resultant modulated photodetector current vs. time, which is proportional to the optical intensity impinging on the photodetector for an ideal photodetector. Again, in the absence of rotation, the output at points A and B are equal, while the presence of rotation makes the output unequal for the "A" half periods and "B" half periods. In the square wave demodulation process depicted in FIGS. 5a, 5b and 5c, the signal component synchronous with the bias modulation frequency f_b is recovered from the photodetector signal by multiplying by a square wave demodulator reference waveform of zero mean, synchronized to the bias modulation. The average, or DC component of the resultant demodulated output is proportional to rotation rate.

One other method of recovering the rotation rate, shown in FIG. 6, is that of a digital demodulation scheme where the output of the photodetector in a square wave modulated system is sampled at points A_i during the first half cycle and points B_i during the second half cycle. The sample event is represented by an arrow. Each sample is converted from an analog signal to a digital one and the difference between the digital sum of the A_i 's and the digital sum of the B_i 's is proportional to Ω .

In all of these cases, the PSD/digital demodulator output is an odd function having a large rate of change at zero phase shift, and thus changes algebraic sign on either side of zero phase shift. Hence, the phase-sensitive detector PSD/digital demodulator signal can provide an indication of which

direction a rotation is occurring about the axis of the coil, and can provide the large rate of change of signal value as a function of the rotation rate near a zero rotation rate, i.e., the detector has a high sensitivity for phase shifts near zero so that its output signal is quite sensitive to low rotation rates. This is possible, of course, only if phase shifts due to other sources, that is, errors, are sufficiently small. In addition, this output signal in these circumstances is close to being linear at relatively low rotation rates. Such characteristics for the output signal of the demodulator/PSD are a substantial improvement over the characteristics of the output current of the photodetector without optical phase modulation.

An example of such a system from the prior art is shown in FIG. 1. The optical portion of the system contains several features along the optical paths to assure that this system is reciprocal, i.e., that substantially identical optical paths occur for each of the opposite direction propagating electromagnetic waves except for the specific introductions of non-reciprocal phase difference shifts, as will be described below. The coiled optical fiber forms a coil **10** about a core or spool using a single mode optical fiber wrapped about the axis around which rotation is to be sensed. The use of a single mode fiber allows the paths of the electromagnetic or light waves to be defined uniquely, and further allows the phase fronts of such a guided wave to also be defined uniquely. This greatly aids maintaining reciprocity.

In addition, the optical fiber can be so-called polarization-maintaining fiber in that a very significant birefringence is constructed in the fiber so that polarization fluctuations introduced by unavoidable mechanical stresses, by the Faraday effect in magnetic fields, or from other sources, which could lead to varying phase difference shifts between the counter-propagating waves, become relatively insignificant. Thus, either the high refractive index axis, i.e., the slower propagation axis, or the low index axis is chosen for propagating the electromagnetic waves depending on the other optical components in the system.

The electromagnetic waves which propagate in opposite directions through coil **10** are provided from an electromagnetic wave source, or light source **11**, in FIG. 1. This source is a broadband light source, typically a semiconductor superluminescent diode or a rare earth doped fiber light source which provide electromagnetic waves, typically in the near-infrared part of the spectrum, over a range of typical wavelengths between 830 nanometers (nm) and 1550 nm. Source **11** must have a short coherence length for emitted light to reduce the phase shift difference errors between these waves due to Rayleigh and Fresnel scattering at scattering sites in coil **10**. The broadband source also helps to reduce errors caused by the propagation of light in the wrong state of polarization.

Between light source **11** and fiber optic coil **10** there is shown an optical path arrangement in FIG. 1 formed by the extension of the ends of the optical fiber forming coil **10** to some optical coupling components which separate the overall optical path into several optical path portions. A portion of optical fiber is positioned against light source **11** at a point of optimum light emission therefrom, a point from which it extends to a first optical directional coupler **12** which may also be referred to as a optical light beam coupler or wave combiner and splitter.

Optical directional coupler **12** has light transmission media therein which extend between four ports, two on each end of that media, and which are shown on each end of coupler **12** in FIG. 1. One of these ports has the optical fiber

extending from light source **11** positioned thereagainst. At the other port on the sense end of optical directional coupler **12** there is shown a further optical fiber positioned thereagainst which extends to be positioned against a photodiode **13** which is electrically connected to a photodetection system **14**.

Photodiode **13** detects electromagnetic waves, or light waves, impinging thereon from the portion of the optical fiber positioned there against and provides a photo current in response to a signal component selection means **35**. This photocurrent, as indicated above, in the case of two nearly coherent light waves impinging thereon, follows a raised cosine function in providing a photocurrent output which depends on the cosine of the phase difference between such a pair of substantially coherent light waves. This photodetector device will operate into a very low impedance to provide the photo current which is a linear function of the impinging radiation, and may typically be a p-i-n photodiode.

Optical directional coupler **12** has another optical fiber against a port at the other end thereof which extends to a polarizer **15**. At the other port on that same side of coupler **12** there is a non-reflective termination arrangement **16**, involving another portion of an optical fiber.

Optical directional coupler **12**, in receiving electromagnetic waves, or light, at any port thereof, transmits such light so that approximately half thereof appears at each of the two ports of coupler **12** on the end thereof opposite that end having the incoming port. On the other hand, no such waves or light is transmitted to the port which is on the same end of coupler **12** as is the incoming light port.

Polarizer **15** is used because, even in a single spatial mode fiber, light can propagate in two polarization modes through the fiber. Thus, polarizer **15** is provided for the purpose of passing light propagating of one polarization such that clockwise (cw) and counterclockwise (ccw) waves of the same polarization are introduced into sensing loop **10** and only light from the sensing loop of the same polarization for the cw and ccw waves are interfered at the detector. Polarizer **15**, however, does not entirely block light in the one state of polarization that it is intended to block. Again, this leads to a small non-reciprocity between two opposite direction traveling electromagnetic waves passing there-through and so a small non-reciprocal phase shift difference occurs between them which can vary with the conditions of the environment in which polarizer **15** is placed. In this regard, the high birefringence in the optical fiber used or the broad bandwidth of the light source used again aids in reducing this resulting phase difference, as indicated above.

Polarizer **15** has a port on either end thereof with the electromagnetic wave transmission medium contained therein positioned therebetween. Positioned against the port on the end thereof opposite that connected to optical directional coupler **12** is another optical fiber portion which extends to a further optical bidirectional coupler **17** which has the same wave transmission properties as does coupler **12**.

The port on the same end of coupler **17** from which a port is coupled to polarizer **15** again is connected to a non-reflective termination arrangement **18**, using a further optical fiber portion. Considering the ports on the other end of coupler **17**, one is connected to further optical components in the optical path portions extending thereto from one end of the optical fiber in coil **10**. The other port in coupler **17** is directly coupled to the remaining end of optical fiber **10**. Between coil **10** and coupler **17**, on the side of coil **10**

opposite the directly connected side thereof, is provided an optical phase modulator **19**. Optical phase modulator **19** has two ports on either end of the transmission media contained therein shown on the opposite ends thereof in FIG. **1**. The optical fiber from coil **10** is positioned against a port of modulator **19**. The optical fiber extending from coupler **17** is positioned against the other port of modulator **19**.

Optical modulator **19** is capable of receiving electrical signals to cause it to introduce a phase difference in electromagnetic waves transmitted therethrough by either changing the index of refraction or the physical length of the transmission medium, therein to thereby change the optical path length. Such electrical signals are supplied to modulator **19** by a bias modulation signal generator **20** providing either a sinusoidal voltage output signal at a modulation frequency f_b that is intended to be equal to $C_1 \sin(\omega_b t)$ where ω_b is the radian frequency equivalent of the modulation frequency f_b , or a square wave modulation signal at f_b , and C_1 is the amplitude of the modulation. Other suitable periodic waveforms could alternatively be used.

This completes the description of the optical portion of the system of FIG. **1** formed along the optical path followed by the electromagnetic waves, or light waves, emitted by source **11**. Such electromagnetic waves are coupled from that source **11** through the optical fiber portion to optical directional coupler **12**. Some of such wave entering coupler **12** from source **11** is lost in non-reflecting terminating arrangement **16** coupled to a port on the opposite end thereof, but the rest of that wave is transmitted through polarizer **15** to optical directional coupler **17**.

Coupler **17** serves as a beam-splitting apparatus in which electromagnetic waves entering the port thereof, received from polarizer **15**, split approximately in half with one portion thereof passing out of each of the two ports on the opposite ends thereof. Out of one port on the opposite end of coupler **17** an electromagnetic wave passes through optical fiber coil **10**, modulator **19**, and back to coupler **17**. There, a portion of this returning wave is lost in non-reflective arrangement **18** connected to the other port on the polarizer **15** connection end of coupler **17**, but the rest of that wave passes through the other port of coupler **17** to polarizer **15** and to coupler **12** where a portion of it is transmitted to photodiode **13**. The other part of the wave passed from polarizer **15** to coil **10** leaves the other port on the coil **10** end of coupler **17**, passes through modulator **19**, and optical fiber coil **10** to re-enter coupler **17** and, again, with a portion thereof following the same path as the other portion to finally impinge on photodiode **13**.

As indicated above, photodiode **13** provides an output photocurrent i proportional to the intensity of the two electromagnetic waves or light waves impinging thereon, and is therefore expected to follow the cosine of the phase difference between these two waves impinging on that diode. For sinusoidal bias modulation, the photodiode signal is given by the following equation:

$$i = I_o/2\eta[1 + \cos(\phi_R + \phi_b \cos \omega_b t)] \quad (1)$$

where I_o is the light intensity magnitude at photodetector **13** in the absence of any phase difference between counter-clockwise waves and η is the detector responsivity coefficient. This is because the current depends on the resulting optical intensity of the two substantially coherent waves incident on photodiode **13**, an intensity which will vary from a peak value of I_o to a smaller value depending on how much constructive or destructive interference occurs between the two waves. This interference of waves will change with

rotation of the coiled optical fiber forming coil **10** about its axis as such rotation introduces a phase difference shift of ϕ_R between the waves. Further, there is an additional variable phase shift introduced in this photodiode output current by modulator **19** with an amplitude value of ϕ_b and which is intended to vary as $\cos(\omega_b t)$.

For the case of square wave modulation, the photodiode current is represented by

$$i = \frac{1}{2}\eta I_o [1 + \cos(\phi_R + \phi_b)] \quad (2)$$

Where the amplitude of the phase difference modulation is

$$\phi_b = \begin{cases} |\phi_b| & nT \leq t < \left(n + \frac{1}{2}\right)T \\ -|\phi_b| & \left(n + \frac{1}{2}\right)T \leq t < (n+1)T \end{cases} \quad (3)$$

where $n=0, 1, 2, 3 \dots$, and where T is the bias modulation period. Optical phase modulator **19** is of the kind described above and is used in conjunction with a PSD or digital demodulator **23** as part of an overall detection system for converting the output signal of photodetection system **14**, following a cosine function as indicated above, to a signal function that provides in that output signal, as indicated above, information both as to the rate of rotation and the direction of that rotation (as can be shown by rotation indicator **26**) about the axis of coil **10**.

Thus, the output signal from photodetection system **14**, including photodiode **13**, is converted to a voltage and provided through an amplifier **21**, where it is amplified and passed to PSD/digital demodulator means **23**. Photodetection system **14**, amplifier **21** and PSD/digital demodulator **23** constitute signal component selection means **35**. PSD/digital demodulator **23**, serving as part of a phase demodulation system, is a well known device. Such a PSD/digital demodulator **23** extracts the amplitude of the fundamental frequency f_b of the photodiode **13** output signal, or the fundamental frequency of modulation signal generator **20** plus higher odd harmonics, to provide an indication of the relative phase of the electromagnetic waves impinging on photodiode **13**. This information is provided by PSD/digital demodulator **23**.

Bias modulator signal generator **20**, in modulating the light in the optical path at the frequency f_b described above, also leads to harmonic components being generated by the recombined electromagnetic waves in photodetection system **14**.

In operation, the phase difference changes in the two opposite direction propagating electromagnetic waves passing through coil **10** in the optical path, because of rotation, will vary relatively slowly compared with the phase difference changes due to modulator **19**. Any phase differences due to rotation, or the Sagnac effect, will merely shift the phase differences between the two electromagnetic waves. The amplitude of the modulation frequency component of the output signal of photodetection system **14**, is expected to be set by the magnitude of this phase difference modified further only by the factors of a) the amplitude value of the phase modulation of these waves due to modulator **19** and generator **20**, and b) a constant representing the various gains through the system. Then, the periodic effects of this sinusoidal modulation due to generator **20** and modulator **19** in this signal component are expected to be removed by demodulation in the system containing PSD/digital demodulator **23** leaving a demodulator system (detector) output signal depending on just the amplitude scaling factor thereof.

Thus, the voltage at the output of amplifier **21** will typically appear as:

$$V_{21-out} = \frac{1}{2} I_o \eta k \{1 + \cos[\phi_R + \phi_b \cos(\omega_b t + \theta)]\} \quad (4)$$

for sine wave modulation. The constant k represents the gains through the system to the output of amplifier **21**. The symbol θ represents additional phase delay in the output signal of amplifier **21** at ω_b with respect to the phase of the signal at ω_b on the photocurrent. This phase shift is thus introduced in photodetection system **14**. The other symbols used in the preceding equation have the same meaning as they did in the first equation above.

The foregoing equation can be expanded in a Bessel series expansion to give the following:

$$\begin{aligned} V_{21-out} = \frac{1}{2} I_o \eta k \left\{ [1 + J_0(\phi_b) \cos \phi_R] - 2J_1(\phi_b) \sin \phi_R \cos(\omega_b t + \theta) - \right. \\ \left. 2J_2(\phi_b) \cos \phi_R \cos 2(\omega_b t + \theta) + 2J_3(\phi_b) \sin \phi_R \cos(\omega_b t + \theta) + \right. \\ \left. \sum_{n=2}^{\infty} [(-1)^n J_{2n}(\phi_b) \cos \phi_R \cos 2n(\omega_b t + \theta) - \right. \\ \left. (-1)^n 2k J_{2n+1}(\phi_b) \sin \phi_R \cos(2n+1)(\omega_b t + \theta)] \right\} + \\ \left. \sum_{n=2}^{\infty} [(-1)^n J_{2n}(\phi_b) \cos \phi_R \cos 2n(\omega_b t + \theta) - \right. \\ \left. (-1)^n 2k J_{2n+1}(\phi_b) \sin \phi_R \cos(2n+1)(\omega_b t + \theta)] \right\}. \end{aligned} \quad (5)$$

This signal at the output of amplifier **21** is applied to the input of PSD **23**, as is the signal from bias modulator generator **20**, the latter again intended to be equal to $C_1 \sin(\omega_b t)$ where ω_b is the radian frequency equivalent of the modulation frequency f_b . Assuming that PSD **23** picks out only the signal of interest at ω_b , the output of that detector with such a generator **20** output signal will then be the following:

$$V_{23-out} = I_o \eta k J_1(\phi_b) \sin \phi_R \quad (6)$$

The constant k' accounts for the system gains from photodetector **13** output current through PSD/digital demodulator **23**.

A similar result is obtained for square wave bias modulation where the photocurrent is

$$i = \begin{cases} \frac{1}{2} I_o \eta [1 + \cos \phi_R \cos |\Delta \phi_b| - \sin \phi_R \sin |\Delta \phi_b|] & t_1 \leq t < t_2 \\ \frac{1}{2} I_o \eta [1 + \cos \phi_R \cos |\Delta \phi_b| + \sin \phi_R \sin |\Delta \phi_b|] & t_2 \leq t < t_3 \end{cases} \quad (7)$$

where

$$t_1 = nT$$

$$t_2 = (n + \frac{1}{2})T$$

$$t_3 = (n+1)T$$

$$\text{and } n=0, 1, 2, \dots$$

and the output of PSD **23** will be

$$V_{23-out} = K'' I_o \eta \sin \phi_R \sin |\Delta \phi_b| \quad (8)$$

where K'' is a constant of proportionality that includes the amplifier gains between the photodetector **14** current output and the PSD **23** output.

As can be seen from these equations, the output of PSD/digital demodulator **23** depends on the rotation rate.

However, there may be error terms that may prevent the device from achieving the expected results in the system of FIG. 1. One reason for failing to achieve the expected results is that bias modulation signal generator **20**, in modulating the light in the optical path at frequency f_b as described above through phase modulator **19**, not only results in harmonic components being generated in photodetection system **14** by the recombined electromagnetic waves, but also directly supplies some harmonic components in the varying optical path phase because of nonlinearities occurring both in generator **20** and modulator **19**.

That is, as a first possibility, the output signal supplied by modulation generator **20** at its output may contain not only a fundamental signal at frequency f_b , but also significant harmonics thereof. Even if a signal free of such harmonics could be provided, nonlinear component characteristics and hysteresis in phase modulator **19** can result in introducing such harmonics into the varying phase provided thereby in the optical path. Such harmonics can lead to significant rate bias errors in the output signal of the fiber optic gyroscope. Thus, there is desired an interferometric fiber optic gyroscope in which such errors due to the modulation system are reduced or eliminated.

The "proper" frequency is selected to be that frequency which results in the modulating of one of the waves 180 degrees out of phase with the modulation of the other. This modulation providing 180 degrees of phase difference between the two waves has the effect of eliminating modulator induced amplitude modulation of the resulting photodetector signal. The value of the "proper" frequency can be determined from the length of the optical fiber and the equivalent refractive index therefor.

The resulting signal output of PSD **23** follows a sine function, i.e. the output signal depends on the sine of the phase difference between the two electromagnetic waves impinging on the photodiode **13**, primarily the phase shift due to rotation about the axis of the coil **10**. A sine function is an odd function having its maximum rate of change at zero, and so changes algebraic sign on either side of zero. Hence, the phase sensitive demodulator signal can provide both an indication of which direction a rotation is occurring about the axis of coil **10**, and can provide the maximum rate of change of signal value as a function of rotation rate near a zero rotation rate, i.e., has its maximum sensitivity near zero phase shifts, so that its output signal is quite sensitive to low rotation rates. This is possible, of course, only if phase shifts due to other sources, that is, errors, are made sufficiently small. In addition, this output signal in these circumstances is very close to being linear at relatively low rotation rates. Such characteristics for the output signal of the phase sensitive demodulator **23** are a substantial improvement over the characteristics of the output current of photodetector **14**.

Nevertheless, the phase sensitive demodulator **23** output, in following a sine function, results in an output that at rotation rates further from zero, is less and less linear. The output does not become linear again until large enough rotation rates are encountered that give optical phase difference shifts of $\phi_R = \pm m\pi$, where m is an integer. In fact, the output of demodulator **23** is zero at $\phi_R = 0$ or $\phi_R = \pm m\pi$ and linear in regions close to these values. There is a strong desire to operate the gyroscope at a null, thereby gaining a gyro scale factor that is independent of the output signal size, gains of the electronics and having phase sensitive demodulator **23** stay within its linear operation region near its null condition.

This can be accomplished by adding a further phase modulator **19**, or frequency shifter, near the end of the coil **10** in an optical path portion used by the opposite direction traveling electromagnetic waves propagating through the coiled optical fiber **10** to reach the photodetector **13**. This phase modulator **19**, or frequency shifter, is operated in a feedback loop from the photodetector system **14**, i.e., the so-called rate loop, and provides sufficient negative feedback such that phase modulator **19** introduced phase change ϕ_f is just enough to cancel the phase shift difference between the opposite traveling direction electromagnetic waves resulting from a rotation about the axis of the coiled optical fiber **10** or enough such that $\phi_f = -\phi_R \pm m\pi$.

The resultant photodetector **13** current in such a closed loop system can now be represented as

$$i = \frac{I_o\eta}{2} [1 + \cos(\phi_R + \phi_f + \phi_b \cos \omega_b t)]$$

$$i = \frac{I_o\eta}{2} [1 + \cos(\phi_R + \phi_f + \phi_b \cos \omega_b t)]$$

for the sine-wave modulated system, and hence if $\phi_f = -\phi_R \pm m\pi$, then it can be shown that $V_{23-out} = 0$. Likewise, in the case of square wave demodulation

$$i = \begin{cases} \frac{1}{2} I_o\eta [1 + \cos(\phi_R + \phi_f) \cos|\phi_b| - \sin(\phi_R + \phi_f) \sin|\phi_b|] & t_1 \leq t < t_2 \\ \frac{1}{2} I_o\eta [1 + \cos(\phi_R + \phi_f) \cos|\phi_b| + \sin(\phi_R + \phi_f) \sin|\phi_b|] & t_2 \leq t < t_3 \end{cases} \quad (10)$$

and $V_{23-out} = 0$ when the closed loop system adjusts $\phi_f = -\phi_R \pm m\pi$.

As a result of the rate loop, there will be little net average phase shift $\phi_N = \phi_f + \phi_R$ from $0 \pm m\pi$ occurring at photodetector **13** except for transient rotation rate changes, and so little net average phase shift sensed by phase sensitive demodulator **23**. Thus, the DC-averaged output signal of this phase sensitive demodulator **23** will always be near to, or at, zero. This is true, because the feedback gain of a typical servo loop is extremely high near frequencies close to zero. The signal from a generator **20** connected to phase sensitive demodulator **23** for operating this additional phase modulator **19**, through providing a signal directing the modulator to provide a particular phase shift sufficient to cancel the phase shift due to rotation or make $\phi_f = -\phi_R \pm m\pi$ will thus contain within it or a related signal the information as to the magnitude and direction of the rotation rate and the value of m .

Several forms for the output signal from the generator **20** connected to phase sensitive demodulator **23** in the rate feedback loop have been suggested for operating this additional optical phase modulator **19**. One common and good choice is to use a serrodyne generator which applies a sawtooth-like signal to optical phase modulator **19**. A sawtooth or sawtooth-like signal is chosen because it can be shown that an ideal sawtooth signal of 2π phase amplitude provides what amounts to a pure frequency translation for the modulated electromagnetic waves, a single-sideband modulator. As a result, light passing through the phase modulator being operated with such a sawtooth signal will leave modulator **19** with its frequency translated by an amount equal to the frequency of the sawtooth signal. A non-ideal sawtooth signal won't result in pure frequency translation, there instead will be added harmonics generated which can be kept small by providing very nearly an ideal sawtooth waveform of 2π amplitude and by careful design of the modulator.

Another type of modulation waveform is called a dual ramp waveform that consists of a linear ramp of positive slope followed by a ramp of negative slope. In this case, the feedback loop alternately locks to $\phi_N = -\pi$ and $\phi_N = +\pi$ or more generally to $\phi_N = m\pi$ and $\phi_N = (m+2)\pi$. In the absence of rotation, the slope magnitudes of the up-ramp and the down-ramp are equal. In the presence of rotation, the slope magnitudes are different with the magnitude of the difference in slopes between the two ramps being proportional to the rotation rate magnitude. Which ramp, the up-ramp or the down-ramp, has the greater slope magnitude is an indication of rotational directions. This technique has the performance advantage that there is no fast fly-back required in the phase shifter voltage as is the case with the serrodyne waveform.

The following discussion will assume the use of serrodyne feedback modulation for the purposes of illustration, but dual ramp or other modulation schemes could be used as well. In addition, it is recognized that the bias modulation and the feedback ramp may be added together and applied to a single or multiple phase modulators.

Since optical phase modulator **19** so operated will be on one side of the coiled optical fiber **10**, one of the electromagnetic waves will have its frequency translated upon entering coil **10** while the other will not have its frequency translated until it exits the coil. Hence, one wave traverses the loop having a higher frequency than the other (though both have the same frequency on reaching the photodetector) with the result that, for a fixed modulator (or serrodyne generator) frequency, one will have a phase shift with respect to the other at photodetector **13** in an amount set by the frequency of the sawtooth and the optical length of the fiber of $2\pi\tau\Delta f$. Here, Δf is the modulator **20** or generator frequency, and τ is the transit time of the light waves through the coil. This phase shift will act to counter the phase shift between the light waves, caused by rotation, because of the negative feedback loop in which the modulator is provided. Thus, the frequency of the sawtooth, or sawtooth-like generator output signal will be an indication of the rotation rate, and the polarity of the sawtooth will indicate the direction of rotation.

One example of a rate feedback loop is shown in FIG. 7. Rather than to the rotation rate indicator of FIG. 1, the signal from phase sensitive detector **23** goes to servo electronics **24** which is incorporated in FIG. 7. In response to such phase difference, servo electronics **24** outputs a phase ramp signal **25** provided by a loop closure waveform generator **29** that supplies the phase ramp to modulator **19** in the form of signal **28** to phase-shift one beam relative to the other beam so as to bring the beams in phase with each other. A signal either from the servo electronics **24** or loop closure waveform generator **29** contains the magnitude and sign of the phase difference between optical waves. Summing amplifier **27** also supplies in signal **28** the bias modulation signal to this phase modulator **19**. The feedback signal required to return beams into phase, such as the frequency of the sawtooth in the serrodyne modulation case, is an indication of the rate of rotation of sensing loop. In this closed loop case the modulator of choice is typically a phase modulator **19** on an integrated optic chip (IOC) **30** shown in FIG. 7 in order to accommodate the necessary high frequency content of the desired phase ramp signal which may be a sawtooth or a dual-ramp-type triangular wave. The signal **25**, indicative of rotation, is then supplied to a rotation rate indicator **26** which provides a convenient and readily useful indication of rotation rate of loop. In the case of employing a phase modulator **19** on an integrated optical chip (IOC) **30** it is also convenient to implement coupler function **17** of FIG. 1 as a

y-junction **31** on the IOC and to implement the polarizer **15** on the IOC chip or construct the IOC waveguides using a single polarization design. Y-junction **31** may be regarded as an optical lightwave or beam splitter/combiner, like that as of coupler **12**.

In general, there may be reasons why the fiber optic gyro does not give the expected rotation sensing accuracy. One of these is due to the presence of vibration. There may be vibration-induced periodic stretching of the fiber or periodic strain in interferometer loop after the light is split into two waves to counterpropagate around the sensing coil **10** can cause a periodic phase difference modulation to the two light waves if the strain response to vibration is not equally applied to all fiber points located symmetrically in the sensing loop; that is, points located symmetrically from the center of the loop. This time varying phase difference shift δ at the vibration frequency f_v of amplitude $\Delta\phi_v$ can be written as

$$\delta = \Delta\phi_v \cos(\omega_v t + \epsilon) \quad (11)$$

where $\omega_v = 2\pi f_v$ and ϵ is an arbitrary phase. In this case, the error due to δ itself is a rapidly varying function with a zero mean, and averages to zero and does not cause a time-averaged error. As long as $\Delta\phi_v$ is small, this error in itself does not cause a large problem in most applications. Another cause of optical phase difference shift δ at angular frequency ω_v due to vibration is that of a actual angular or torsional vibration which induces a true AC rotation rate. This effect takes the same functional form for a vibration-induced phase difference modulation $\delta = \Delta\phi_v \cos(\omega_v t + \epsilon)$ and the output of the gyro will correctly indicate the actual rotation rate environment by having its output suitably vary at ω_v . Again, it must be noted that ideal gyro operation would indicate no DC or average rotation rate when the input rate was assumed to be an AC phenomena for this case. However, in either of the two above situations, the presence of other synchronously-induced vibration effects in the gyro (in combination with the phase difference modulation δ) may cause a rectified error with a non-zero average value which does appear falsely as an indication of steady state rotation rate. One such secondary effect is that of intensity modulation in the optical circuit caused by vibration. This may be due to the modulation of microbending losses in the fiber, both inside and outside the interferometer loop or to the light source **11** fiber pigtail. Another source of intensity modulation may be due to modulation of fiber stress points that convert light to the unwanted polarization state in the gyro path and this light will be eliminated by polarizer **15** before reaching the photodetector. The latter effect produces signal intensity modulation and may be caused by the modulation of polarization in source **11**, in the source pigtail, in the IOC fiber pigtail to the IOC chip **30**, or in coil **10**. This effect may also be caused by modulating stresses inside the IOC **30** or coupler **17** or source **11** packages.

The optical intensity modulation in any of these cases can be represented by,

$$I_o = I_a(1 + \alpha \sin[\omega_v t]) \quad (12)$$

where I_a is the average intensity impinging on the photodiode **13** during vibration without bias modulation. Neglecting steady state or DC rotation rate to simplify the mathematical analysis, the error due to vibration can be derived by noting that the photodiode **13** output current for a sine wave bias modulation system is given by

$$i = \frac{1}{2} I_o \eta (1 + \cos[\phi_b \cos(\omega_b t + \theta) + (\delta + \phi_R)]) \quad (13)$$

The output of demodulator **23**, which selects the signal component at f_b , can be shown to be

$$V_{23-out} = \eta k' I_o J_1(\phi_b) \sin(\delta + \phi_R) \quad (15)$$

$$V_{23-out} = \eta k' I_o J_1(\phi_b) \sin(\delta + \phi_R)$$

$$= \eta k' I_a (1 + \alpha \sin[\omega_v t]) J_1(\phi_b) \{ \sin[\Delta\phi_v \cos(\omega_v t + \epsilon)] + \sin\phi_R \}$$

$$= \eta k' I_a (1 + \alpha \sin[\omega_v t]) J_1(\phi_b) \{ \sin[\Delta\phi_v \cos(\omega_v t + \epsilon)] + \sin\phi_R \}$$

where it was assumed that $\Delta\phi_v$ and ϕ_R are small so that $\cos[\Delta\phi_v \cos(\omega_v t + \epsilon)] = 1$ and $\cos\phi_R = 1$. It can be shown that it can be simplified to

$$V_{23-out} = \eta k' I_a J_1(\phi_b) \{ -\alpha J_1(\Delta\phi_v) \sin\epsilon + 2J_1(\Delta\phi_v) \cos(\omega_v t + \epsilon) + \quad (16)$$

$$\alpha J_1(\Delta\phi_v) \sin(2\omega_v t + \epsilon) + \alpha J_3(\Delta\phi_v) \sin(2\omega_v t + \epsilon) \} +$$

$$\eta k' I_a J_1(\phi_b) \sin\phi_R [1 + \alpha \sin\omega_v t]$$

$$V_{23-out} = \eta k' I_a J_1(\phi_b) \{ -\alpha J_1(\Delta\phi_v) \sin\epsilon + 2J_1(\Delta\phi_v) \cos(\omega_v t + \epsilon) +$$

$$\alpha J_1(\Delta\phi_v) \sin(2\omega_v t + \epsilon) + \alpha J_3(\Delta\phi_v) \sin(2\omega_v t + \epsilon) \} +$$

$$\eta k' I_a J_1(\phi_b) \sin\phi_R [1 + \alpha \sin\omega_v t]$$

The approximation of $\Delta\phi_v \ll 1$ rad has been made and that we have dropped terms at higher frequencies than $2\omega_v t$. The first term in the above equation is a "DC" or rectified term that does not average to zero, giving a false indication of rotation rate. The other terms average to zero over a period long compared to ω_v^{-1} . The rectified error or bias is a product of the intensity modulation of amplitude α and the phase difference modulation at f_v of amplitude $\Delta\phi_v$. The rectified error vanishes when the intensity modulation and the phase modulation are 90° out of phase, i.e., $\epsilon = 0$ and is peaked when they are in phase, i.e., $\epsilon = 90^\circ$. Note that in a typical gyroscope application device bandwidths of around a few hundred hertz are required. By merely low-pass filtering the output any terms in the kHz range may be attenuated. However the rectified error, due to vibration in the kHz or higher region, will not be removed and will cause errors.

Similarly, it can be shown that the same rectified bias occurs for the square wave bias-modulated system. Here, the photodiode signal is given by

$$i = \frac{1}{2} \eta I_o (1 + \cos[\phi_b + \delta + \phi_R]) \quad (17)$$

Using a typical case of $|\phi_b| = \pi/2$ for simplicity, that is

$$\phi_b = \begin{cases} \frac{\pi}{2} & nT \leq t < \left(n + \frac{1}{2}\right)T \\ -\frac{\pi}{2} & \left(n + \frac{1}{2}\right)T \leq t < (n+1)T \end{cases} \quad (18)$$

where $n=0, 1, 2, 3 \dots$

This gives a photodiode current signal of

$$i(t) = \begin{cases} \frac{1}{2} \eta I_o (1 - \sin[\delta + \phi_R]) & nT \leq t < \left(n + \frac{1}{2}\right)T \\ \frac{1}{2} \eta I_o (1 + \sin[\delta + \phi_R]) & \left(n + \frac{1}{2}\right)T \leq t < (n+1)T \end{cases} \quad (19)$$

The average output of the square wave demodulator will then be

$$\langle V_{23-out} \rangle = \eta I_o k'' \sin[\delta + \phi_R] \langle V_{23-out} \rangle = \eta I_o k'' \sin[\delta + \phi_R] \quad (20)$$

where k'' is a constant representing the gain of the electronics chain through the demodulator and the $\langle \rangle$ represents the

time average of the signal over the bias modulation cycle. Substituting for the values of I_o and δ gives

$$\langle V_{23-out} \rangle = \eta k'' I_a (1 + \alpha \sin(\omega_v t)) \{ \sin[\Delta\phi_v \cos(\omega_v t + \epsilon)] + \sin\phi_R \} \quad (21)$$

where again ϕ_R and $\Delta\phi_v$ are assumed to be $\ll 1$. This gives the same result as the sinusoidal case if $J_1(\phi_b) \rightarrow 1$ and $k' \rightarrow k''$.

Reference one in the prior art does point out that this rectified error may be reduced in amplitude by the following means. The first method is to use a quadrupolar coil **10** winding pattern aimed at reducing $\Delta\phi_v$ by causing fiber segments inside the coils that are equidistant from the coil center to experience the same strain when vibrated. The second method is to reduce $\Delta\phi$ by impregnating coil **10** with varnish to prevent mechanical motion of the coil fibers under the influence of vibration. A third method is to improve the mechanical ruggedness of the source module, IOC **30** packaging and component packaging to attenuate intensity modulation resulting from fiber pigtail and fiber motion in a vibrational environment. The last is to enhance the rigidity of the mounting features in the gyro to reduce mechanical stress on optical components and subassemblies during vibration.

The first part of this invention relates to attenuation of the rectified bias error primarily through reduction of the vibration induced intensity modulation. This can be effectively accomplished by sensing photodiode **13** signal in the range of expected vibration frequencies f_v , typically 5 Hz to 3 kHz. This provides an in-situ measurement of α , the intensity modulation amplitude, which in turn may be used in a signal processing system to directly compensate for intensity variations at f_v , which will be described in the following description.

A key element of this scheme is the ability to independently observe the intensity modulation, $\alpha \sin\omega_v t$. It should be noted that the instantaneous intensity at photodiode **13**, i.e.,

$$I = \frac{1}{2} I_o (1 + \cos[\phi_b \cos\omega_b t + \delta + \phi_R + \phi_f]) \quad (22)$$

has already been analyzed for its spectral content at ω_b , which is essentially measured in PSD/digital demodulator **23**. This frequency content ranges typically from 25 kHz to 2 MHz for gyros operating at the proper frequency of a sensing coil of 4 km length to 50 m length, respectively. Important information, however, exists near baseband, i.e., the photodetector **13** signal content from 0 Hz to 3 kHz, the frequency range of the intensity modulation induced by vibration. This baseband signal content I_L is given by,

$$I_L = I_o [1 + J_o(\phi_b) \cos(\delta + \phi_R + \phi_f)] \quad (23)$$

$$= I_a [1 + \alpha \sin(\omega_v t)] [1 + J_o(\phi_b) \cos(\delta + \phi_R + \phi_f)] \quad (24)$$

for the sine wave modulated case.

Assuming $\delta + \phi_R$ is $\ll 1$, the $\cos(\delta + \phi_R)$ is approximately unity. Hence I_L is a direct measure of the intensity of modulation in the optical circuit in the presence of vibration. This is also true in the square wave modulated case where (assuming $|\phi_b| = \pi/2$)

$$I_L = \frac{1}{2} I_a (1 + \alpha \sin\omega_v t) \quad (25)$$

The corresponding photodetector current near baseband caused by I_L is given by

$$i_L = \frac{1}{2} I_a \eta (1 + \alpha \sin\omega_v t) \quad (26)$$

FIG. **8** shows a method of actively sensing i_L and compensating the main gyro photodetector signal for variations in

I_L , and thus reduce the rectified bias error. This method called an intensity compensator was the subject of U.S. patent application Ser. No. 08/879,902 filed on Jun. 19, 1997. Here, again, rotation is sensed as described in the prior art either obtaining the open-loop output of PSD **23** for the rotation indication or using the output of PSD **23** to close the rate servo loop with a loop closure waveform in response to rotation as shown in FIG. **8**. In either case, this signal amplitude stabilization technique employs an "intensity compensator" **46** in the electrical signal path after photodiodes **13**, **14** but before demodulator **23**. It does not stabilize the photodiode signal at frequency f_v , but it does the equivalent function from the standpoint of vibration error rectification reduction, i.e., it normalizes the signal prior to the demodulation process. In this case, intensity changes at f_v due to vibration are observed at signal photodiode **13**. The variations of interest at the vibration frequency band of interest are separated out by a filtering process **47**, amplified **48** and fed forward to change the gain of the signal at the frequencies of interest. If the signal intensity at the photodiode falls because of vibration, the gain of amplifier **48** is increased to by an output of divider **49** to compensate for this variation. Likewise, it is decreased by the output of divider **49** to compensate for photodiode **13** signal increases. In this way the compensated signal **50** has no (or significantly reduced) variations at f_v or in the range of possible values of f_v . The low pass filter **47** may be tailored to optimize signal variation attenuation versus frequency, obtaining the desired attenuation properties. This method has some advantages in addition to being useful for cases where multiple gyros are sharing a common light source **11**. These are:

1. It is an open loop intensity compensation technique. The filtering required to eliminate the gyro rate induced signals from the AM signals is not restrained by the typical closed loop stability requirements. Because gain and phase margin requirements do not exist, complex filtering can be applied without concern for how phase affects stability. This overcomes the inherent limitations on bandwidth and gain that a closed loop system imposes.
2. It applies the adjustment to the signal without a delay. The bandwidth of the compensation is controlled entirely by the local dedicated filters. In contrast, approaches which may control the laser diode current using negative feedback are bandwidth limited by the fiber loop transit time and other signal processing delays.
3. For small intensity modulation levels the inverse characteristic can effectively be approximated by measuring the gain error, normalizing, negating, and adjusting the output gain. The circuit can be implemented in either digital or analog components with very high bandwidth. The scaling of the output gain sensitivity to the adjustment input can be tailored long term to compensate for temperature, life or other typical variations in the circuit. Intentional perturbations in the light source output could be introduced to allow continuous calibration of the circuit where extremely good performance is desired.

In this way, the input signal that is intensity modulated due to vibration represented by the term $[1 + \alpha \sin(\omega_v t)]$, is compensated in the signal processing intensity compensator arrangement of FIG. **8** by changing the gain of the signal path by a variable gain $g(t)$ in response to the intensity modulation. Here $g(t)$ is the amplifier gain of amp **A** which is varying in time in response to the inverse of the baseband intensity $I_L = \frac{1}{2} I_a [1 + \alpha \sin(\omega_v t)]$. This was described in U.S. patent application Ser. No. 08/879,902 filed on Jun. 19, 1997. As can be seen in FIG. **8**, the signal path is compen-

sated prior to demodulation which is represented by multiplying the signal in eqn 13 (modified for closed loop by adding ϕ_f term) by variable gain $g(t)$. Hence the output of amplifier A is given by

$$V_{A-out} = \frac{1}{2} I_o \eta (1 + \alpha \sin[\omega_v t]) g(t) [1 + \cos(\omega_v t + \theta + \delta + \phi_R + \phi_f)] \quad (\text{eqn 27})$$

for the case of sinusoidal modulation

The gain $g(t)$ of amplifier A is given by,

$$g(t) = \frac{g_o}{(1 + \alpha \sin \omega_v t)} \quad (\text{eqn 28})$$

where g_o is a constant. This assumes, for simplicity of illustration that the low pass filter has a flat gain at DC and in the range of vibration frequencies ω_v , and that the intensity is only varying at one vibration frequency ω_v . However, the equations could be generalized for the case of multiple vibration frequencies and a more complex filter function. Substituting equation (28) into equation (27) shows the $g(t)$ compensates out signal variations at ω_v , i.e., α drops out, and no rectified bias is present any longer. That is shown in the open loop system by setting $\alpha=0$ in equation 16, and in the closed loop system by letting $\phi_R \rightarrow \phi_R + \phi_f$ in equation 16 and then setting $\alpha=0$.

SUMMARY OF INVENTION

Another apparatus used for eliminating or attenuating vibration-induced errors due to vibration rectification is one that applies a variable weighting function at the demodulator by effectively changing the size of the demodulator reference signal. This can be illustrated by the following demonstration. In the case of sinusoidal modulation and demodulation, the signal at the photodetector (with no vibration) is given by eqn 5. It contains many harmonics of ω_b . The step of demodulation essentially pulls out the component of interest at ω_b by multiplying by a periodic signal that is phase-locked to the modulation signal, then time averaging the result. Typically, but not necessarily, the periodic signal may be a sine wave and time-averaging may be accomplished in the demodulator by a low-pass filter. The first step may thus be implemented by analog multiplication, i.e., taking V_{2-out} from equation 5 and then multiplying it by $W_t = \cos(\omega_b t + \theta)$

$$W(t)V_{21-out} = \frac{1}{2} I_o \eta k \left\{ [1 + J_o(\phi_b) \cos \phi_R] \cos(\omega_b t + \theta) - 2J_1(\phi_b) \sin \phi_R \left[\frac{1}{2} + \frac{1}{2} \cos 2(\omega_b t + \theta) \right] - 2J_2(\phi_b) \cos \phi_R \left[\frac{3}{4} \cos(\omega_b t + \theta) + \frac{1}{4} \cos 3(\omega_b t + \theta) \right] + 2J_3(\phi_b) \sin \phi_R \left[\frac{3}{8} + \frac{1}{2} \cos 2(\omega_b t + \theta) + \frac{1}{8} \cos 4(\omega_b t + \theta) \right] \right\} \quad (\text{eqn 29})$$

Talking the time average of the above equation gives the desired result. Assuming some constant demodulator gain the output of the demodulator is,

$$\langle V_{21-out} W(f) \rangle = I_o \eta k J_1(\phi_b) \sin \phi_R \quad (\text{eqn 30})$$

where k' is a constant and the $\langle \rangle$ symbol indicates the time average. Equation (30) thus represents the same result as equation (6). It may be generalized to include vibration effects and closed loop operation by substituting for I_o from eqn 12 and by letting $\phi_R \rightarrow (\phi_R + \delta + \phi_f)$.

Similarly square demodulation may be depicted as multiplication by the function $H(t)$ and then time averaging,

where $H(t)$ is given by,

$$H(t) = \begin{cases} -1 & t_1 \leq t < t_2 \\ +1 & t_2 \leq t < t_3 \end{cases} \quad (\text{eqn 31})$$

where t_1, t_2, t_3 are defined in eqn 7.

Thus, if the signal detector current is given by eqn 7, then

$$H(t)i(t) = \begin{cases} \frac{1}{2} I_o \eta [-1 - \cos \phi_R \cos |\Delta \phi_B| + \sin \phi_R \sin |\Delta \phi_B|] & t_1 \leq t < t_2 \\ \frac{1}{2} I_o \eta [1 + \cos \phi_R \cos |\Delta \phi_B| + \sin \phi_R \sin |\Delta \phi_B|] & t_2 \leq t < t_3 \end{cases} \quad (\text{eqn 32})$$

Taking the time average merely requires addition of the values in the two intervals weighted by the time in each interval and division by the total period $t_3 - t_1 = T$. Assuming, again, a constant gain, the demodulator output is given by,

$$\langle H(t)i(t) \rangle = k' I_o \eta \sin \phi_R \sin |\Delta \phi_B| \quad (\text{eqn 33})$$

which is the same result as eqn 8. Again, this equation may be generalized to include the effects of vibration by substituting from eqn 12 for I_o and letting $\phi_R \rightarrow \phi_R + \phi_f + \delta$.

BRIEF DESCRIPTION OF THE DRAWINGS

FIG. 1 shows a basic interferometric fiber optic gyroscope.

FIG. 2 is a graph of detected optical intensity or output current of a photodetector versus phase difference of counterpropagating light waves in the sensing coil of a fiber optic gyroscope.

FIGS. 3a and 3b show the phase differences of the optical light waves and outputs of the gyroscope for zero and non-zero rotation rates, respectively.

FIGS. 4a and 4b reveal the phase differences of the optical waves and outputs of the gyroscope for zero and non-zero rotation rates, respectively, for square wave modulation.

FIGS. 5a, 5b and 5c show signal components synchronous with the bias modulation signal.

FIG. 6 reveals a sampling scheme for a photodetector output.

FIG. 7 shows an interferometric fiber optic gyroscope having a rate feedback loop.

FIG. 8 shows an intensity compensator for a fiber optic gyroscope.

FIG. 9 reveals a basic concept of the invention.

FIGS. 10a, 10b and 10c show a sampling scheme of the invention.

FIG. 11 reveals a filter approach for adjusting a gain of an analog-to-digital converter.

FIGS. 12a and 12b show older and newer schemes of processing samples from the analog-to-digital converter.

FIG. 13 is a variant of the scheme shown in FIG. 12b.

DESCRIPTION OF THE EMBODIMENTS

The focus of the invention is shown in FIG. 9 for the case of sinusoidal modulation and demodulation but can be shown in the cases of 1) square wave modulation and square wave or sine wave demodulation and 2) square wave modulation and digital demodulation. In this invention, the values of the demodulator reference signals, represented by $H(t)$ or

$\omega(t)$ in the preceding treatments are made to vary in a vibrating environment so as to eliminate or attenuate the vibration rectification effects in the gyroscope. This is accomplished, as shown in FIG. 9, by first sensing the baseband value of the signal photodetector which is affected by the undesirable effects of intensity modulation of amplitude α at frequency ω_v , represented in eqn 12. This output then feeds a voltage controlled signal generator or amplifier 51 that modulates the amplitude of the demodulator reference signal. Referring to FIG. 9, the reference signal to the demodulator would now be increased when the intensity I_o of eqn 12 decreases due to vibration at ω_v and will be decreased when the intensity I_o of eqn 12 increases due to vibration. Thus, the new form of $W(t)$ is given by

$$W(t) = \frac{W_o}{[1 + \alpha \sin(\omega_v t)]} \cos(\omega_b t + \theta) \quad (\text{eqn 34})$$

where W_o is a constant. This again assumes a single frequency of vibration but can be generalized for a general variation in the intensity $I_o(t)$ by letting

$$W(t) = \frac{W'_o}{I_o(t)} \cos(\omega_b t + \theta) \quad (\text{eqn 35})$$

Where W'_o is a constant. Thus, under the influence of vibration, the gyro signal i will be given by eqn 13 for the sinusoidal modulation case and then the demodulation process is given by,

$$\langle \omega(t)i(t) \rangle = \frac{1}{2} \eta I_o \left\{ (1 + \alpha \sin \omega_v t) \left(1 + \cos [\phi_b \cos(\omega_b t + \theta + \delta + \phi_R)] \frac{\omega_o \cos(\omega_b t + \theta)}{(1 + \alpha \sin \omega_v t)} \right) \right\} \quad (\text{eqn 36})$$

which automatically compensates for the intensity modulation of amplitude α . This adjustment eliminates the bias rectification term which is the first term of eqn 16, equivalent to setting $\alpha=0$.

The same concept can be used in reducing the effects of vibration in the case of a system using square wave modulation and demodulation by letting

$$H(t) = \frac{H_o}{[1 + \alpha \sin(\omega_v t)]} \begin{cases} -1 & t_1 \leq t < t_2 \\ +1 & t_2 \leq t < t_3 \end{cases} \quad (\text{eqn 37})$$

where H_o is a constant and t_1 , t_2 and t_3 are defined in eqn 7. It can be shown by evaluating the average of $H(t)i(t)$ where $i(t)$ is given in eqn 19 for a square wave modulated system in the presence of vibration, that the demodulated output contains no DC term, that is, no rectified bias due to vibration. Again, equation 19 may be modified for closed loop operation by letting $\phi_R \rightarrow \phi_R + \phi_f$.

Another system of signal processing, based on digital demodulation is shown in FIG. 10. In this case, the output of the photodetector preamp 52 is "sampled" by a flash A/D converter 53 at a sample rate much faster than the bias modulation frequency. The bias modulation is typically a square wave. As shown in 10b, the sampling is represented by arrows. At each arrow the voltage signal output of the photodetector preamp 52 is converted to a digital number representative of the preamp output. Many samples, η , are performed for half period "a" and half period "b". The "a" samples, a_i , are then accumulated, or added and so are the

"b" samples, b_i , for each modulation period. The rotation rate is recovered by digital demodulation, typically

$$\Omega = k_5 \sum_{i=1}^{i=n} a_i - b_i \quad (\text{eqn 38})$$

for the open loop case where k_5 is a constant of proportionality. In the absence of rotation $\Omega=0$ and the sum in eqn 38 is zero as shown in FIG. 10b. The open loop case of $\Omega \neq 0$ is shown in FIG. 10c and the average a_i 's are different from the b_i 's as shown. During closed loop operation, the loop closure 54 generates a ramp, such as a dual ramp waveform described earlier that restores the output to null, i.e., as illustrated by FIG. 10b. Thus, FIG. 10b represents the closed loop case where

$$\phi_R - \phi_f = k_6 \sum_{i=1}^{i=n} a_i - b_i \quad (\text{eqn 39})$$

and k_6 is a constant, and ϕ_R and ϕ_f are the optical phase differences due to rotation and due to the feedback waveform.

The invention may also be applied to this case in that the weighting function for each sample may be varied in response to the signal amplitude variations due to intensity modulation caused by vibration. This can be done by varying the analog to digital gain of the A/D converter 55 in response to the signal variations represented by,

$$i_L = \frac{1}{2} I_o \eta (1 + \alpha \sin \omega_v t) \quad (\text{eqn 40})$$

Hence, as shown in FIG. 11, the gain of the A/D 55 is adjusted inversely to the baseband current from the signal photodetector 14 which compensates for signal variations into the A/D 55 and prevents vibration rectification. The vibration spectrum and gain signal are determined by low pass filter 56 and gain adjust 57.

Another apparatus 60 is shown in FIG. 12b where a preaccumulator is used to sum the a_i , i.e. $A = \sum a_i$, and the b_i , i.e. $B = \sum b_i$ after sampling. For comparison, a related art version 59 is shown in FIG. 12a. Variations in intensity due to vibration are sensed by adding A and B in an accumulator while the demodulator determines $A-B$ for only one modulation cycle. In this case, in contrast to previous discussions, there is no intended time averaging in the demodulator represented in FIG. 12b. The value of $A+B$ is then divided into the value of $A-B$ to compensate for intensity variations. Time averaging can then be performed on the signal by means of a rate accumulator. This scheme automatically eliminates effects due to variations in i_L due to vibration before time averaging in the rate accumulator. In this way, no vibration-rectified bias occurs.

The approach of FIG. 12b may also be implemented by device 61 as shown in FIG. 13, where preaccumulator 1 automatically sums the a_i during the first half modulation cycle of time t and then decrements for values of b_i during the second half period t of the bias modulation period giving an output that is $A-B$ for one modulation cycle. It is then reset.

The second preaccumulator increments the a_i and the b_i over the first and second modulation half periods to obtain a signal representative of the average intensity over the modulation period. It is reset every $2t$ of time also. Its output is inverted and multiplied by the output of preaccumulator 1 to obtain signal indicative of rotation rate without significant

bias rectification due to vibration. The signal may then be low-pass filtered in an accumulator that drives the loop closure electronics.

One last method of reducing vibration rectification errors is to increase the bandwidth of the primary rate servo so as to counteract the vibration induced phase shift δ at frequency f_v . In the prior art treatments, the primary purpose of the rate servo was to provide a feedback phase shift ϕ_f equal and opposite to that of the rotation rate to be measured. This is reflected in equation 10. Since the rotation rates of interest change slowly, typically at rates of less than 100 Hz, the necessary conventional rate loop bandwidth is at most a few hundred Hz.

However, by expanding the loop bandwidth to have considerable gain up to frequencies beyond that of the expected vibration spectrum, one may attenuate the net phase shift at f_v and therefore attenuate the DC error of equation 16. That is, equation 13 would be modified for a closed loop system to give

$$i = \frac{1}{2} I_o \eta (1 + \cos[\phi_b \cos \omega_b t + (\delta + \phi_R + \phi_f)])$$

$$i = \frac{1}{2} I_o \eta (1 + \cos[\phi_b \cos \omega_b t + (\delta + \phi_R + \phi_f)]) \quad (26)$$

for the case of sinusoidal modulation. It is possible to construct a rate servo that has sufficiently high bandwidth so that the phase shift ϕ_f will not only contain a low frequency component ϕ_{fo} that is equal and opposite to ϕ_R , but also a high frequency component $\Delta\phi_f$ at the frequency f_v . This latter term will produce an oppositely directed phase shift to that of the vibration induced phase modulation at f_v . Thus, the photodetector current may be represented as,

$$i = \frac{1}{2} I_o \eta (1 + \cos[\phi_b \cos \omega_b t + [\Delta\phi_v \cos(\omega_v t + \epsilon) + \Delta\phi_f \cos(\omega_v t + \beta)] + \phi_R + \phi_{fo}])$$

$$i = \frac{1}{2} I_o \eta (1 + \cos[\phi_b \cos \omega_b t + [\Delta\phi_v \cos(\omega_v t + \epsilon) + \Delta\phi_f \cos(\omega_v t + \beta)] + \phi_R + \phi_{fo}])$$

$$i = \frac{1}{2} I_o \eta (1 + \cos[\phi_b \cos \omega_b t + [\Delta\phi_v \cos(\omega_v t + \epsilon) + \Delta\phi_f \cos(\omega_v t + \beta)] + \phi_R + \phi_{fo}]) \quad (27)$$

where β represents a phase angle of the feedback signal of f_v . The net optical phase shift $\Delta\phi_{nv}$ at f_v is a combination of two terms shown in eqn 27,

$$\Delta\phi_{nv} = \Delta\phi_v \cos(\omega_v t + \epsilon) + \Delta\phi_f \cos(\omega_v t + \beta) \quad (28)$$

As the bandwidth of the rate loop is increased, $\Delta\phi_f$ approaches a value of $\Delta\phi_v$, and β approaches $\epsilon + \pi$. Hence, the net phase difference modulation $\Delta\phi_{nv}$ at f_v approaches zero. By substituting $\Delta\phi_{nv}$ for $\Delta\phi_v$ in eqn 16, one can see that the rectification term vanishes as $\Delta\phi_{nv} \rightarrow 0$.

Thus, in this invention, another method of eliminating or reducing vibration rectification errors is to greatly increase the bandwidth of the rate feedback loop, well beyond that needed for rotation sensing, to beyond the expected vibration spectrum. This technique may be used in combination with all intensity servo and intensity compensator arrangements discussed previously. Similarly, it may be used with square wave modulation schemes. Finally, it must be noted that for simplicity, the above discussion focused on sinusoidal vibration inputs. In reality, a real environment contains a superposition of sinusoidal vibration inputs, known as a random or more precisely a pseudo-random vibration spec-

trum. In this case, the cumulative rectified error is a combination of error contributions from arising from vibration at various frequencies. Each error contribution is a result of intensity modulation and a non-zero net optical phase shift at a specific frequency in the spectrum. The techniques discussed in this invention disclosure for eliminating rectification at single frequencies also apply simultaneously to a spectrum of frequencies, i.e., to a random vibration input.

We claim:

1. A vibration rectification error reducer for a fiber optic gyroscope, comprising:

- a light source;
- a coupler having a first port connector to said light source, and having second and third ports;
- a splitter having a first port connected to the second port of said coupler, and having second and third ports;
- an optical fiber coil having a first end connected to the second port of said splitter and a second end connected to the third port of said splitter;
- a detector having an optical port connected to the third port of said coupler, and having an electrical output;
- a bias modulation source having an output;
- a gain-controlled amplifier having a first input connected to the output of said detector, a second input connected to the output of said bias modulation source, and having an output;
- a demodulator having a first input connected to the output of said detector, a second input connected to the output of said gain controlled amplifier;
- an integrator having an input connected to the output of said demodulator and having an output;
- a ramp generator having an input connected to the output of said integrator and having an output;
- a modulator situated proximate to a second port of said splitter, and having an input connected to the output of said ramp generator and to the output of said bias modulation source.

2. A vibration rectification error reducer for a fiber optic gyroscope, comprising:

- a light source;
- a first splitter having a first port connected to an output of said light source;
- a second splitter having a first port connected to a second port of said first splitter;
- an optical fiber coil having a first end connected to a second port of said second splitter and a second end connected to a third port of said second splitter;
- a detector having an optical input connected to a third port of said first splitter;
- a low pass filter having an input connected to an electrical output of said detector;
- an analog-to-digital converter having a first input connected to the output of said detector and having a second input connected to an output of said low pass filter;
- a digital demodulator having an input connected to an output of said analog-to-digital converter;
- an accumulator having an input connected to an output of said digital demodulator; and
- a ramp signal synthesizer having an input connected to the output of said accumulator.

3. The error reducer of claim 2 further comprising:

- a digital-to-analog converter having an input connected to an output of said ramp signal synthesizer; and

21

a modulator proximate to the third port of said second splitter connected to an output of said digital-to-analog converter.

4. A vibration rectification error reducer for a fiber optic gyroscope, comprising:

a light source;

a first splitter having a first port connected to said light source;

a second splitter having a first port connected to a second port of said first splitter;

an optical fiber coil having a first end connected to a second port of said second splitter and a second end connected to a third port of said second splitter;

a detector having an input connected to a third port of said first splitter;

an analog-to-digital converter having an input connected to an output of said detector;

a first accumulator having an input connected to said analog-to-digital converter;

a second accumulator having an input connected to an output of said first accumulator;

an inverter having an input connected to the output of said second accumulator;

a demodulator having an input connected to the output of said first accumulator; and

a multiplier having a first input connected to an output of said demodulator and a second input connected to the output of said inverter.

5. The error reducer of claim 4 further comprising:

a third accumulator having an input connected to an output of said multiplier;

a ramp signal synthesizer having an input connected to an output of said ramp signal synthesizer;

a digital-to-analog converter having an input connected to an output of said ramp signal synthesizer; and

a modulator proximate to the third port of said second splitter, having an input connected to an output of said digital-to-analog converter.

6. A vibration rectification error reducer for a fiber optic gyroscope, comprising:

a light source;

a first splitter having a first port connected to said light source;

a second splitter having a first port connected to a second port of said first splitter;

an optical fiber coil having a first end connected to a second port of said second splitter and a second end connected to a third port of said second splitter;

a detector having an input connected to a third port of said first splitter;

an analog-to-digital converter having an input connected to an output of said detector;

a first accumulator having an input connected to an output of said analog-to-digital converter;

a second accumulator having an input connected to the output of said analog-to-digital converter;

an inverter having an input connected to an output of said second accumulator; and

a multiplier having a first input connected to an output of said first accumulator, and a second input connected to an output of said inverter.

22

7. The error reducer of claim 6 further comprising:

a third accumulator having an input connected to an output of said inverter;

a ramp signal synthesizer having an input connected to an output of said third accumulator;

a digital-to-analog converter having an input connected to an output of said ramp signal synthesizer; and

a modulator proximate to the third port of said second splitter, having an input connected to an output of said digital-to-analog converter.

8. A vibration rectification error reducer for a fiber optic gyroscope, comprising:

a light source;

a coupler having a first port connector to said light source, and having second and third ports;

a splitter having a first port connected to the second port of said coupler, and having second and third ports;

an optical fiber coil having a first end connected to the second port of said splitter and a second end connected to the third port of said splitter;

a detector having an optical port connected to the third port of said coupler, and having an electrical output;

a bias modulation source having an output;

a gain-controlled amplifier having a first input connected to the output of said detector, a second input connected to the output of said bias modulation source, and having an output; and

a demodulator having a first input connected to the output of said detector, a second input connected to the output of said gain controlled amplifier.

9. The error reducer of claim 1, wherein an output of said demodulator is indicative of a rotation rate.

10. A vibration rectification error reducer for a fiber optic gyroscope, comprising:

a light source;

a coupler having a first port connector to said light source, and having second and third ports;

a splitter having a first port connected to the second port of said coupler, and having second and third ports;

an optical fiber coil having a first end connected to the second port of said splitter and a second end connected to the third port of said splitter;

a detector having an optical port connected to the third port of said coupler, and having an electrical output;

a bias modulation source having an output; and

a demodulator having a first input connected to the output of said detector, for detecting a fundamental and/or harmonics of a signal having a frequency of a bias modulation signal from the output of said bias modulation source wherein the fundamental and/or harmonics are indicative of a non-reciprocal phase shift of light propagating in said optical fiber coil and a gain of said demodulator is varied to compensate for amplitude variations that cause the non-reciprocal phase shift.

11. The error reducer of claim 10, wherein the output of said bias modulation source provides a reference signal to a second input of said demodulator.

12. The error reducer of claim 11, wherein an amplitude of the output of said bias modulation source is varied to compensate for changes of amplitude of the signal from the output of said detector due to vibration in the fiber optic gyroscope.

13. A vibration rectification error reducer for a fiber optic gyroscope, comprising:

a light source;
 a first splitter having a first port connected to an output of said light source;
 a second splitter having a first port connected to a second port of said first splitter;
 an optical fiber coil having a first end connected to a second port of said second splitter and a second end connected to a third port of said second splitter;
 a detector having an optical input connected to a third port of said first splitter;
 a low pass filter having an input connected to an electrical output of said detector;
 an analog-to-digital converter having a first input connected to the output of said detector and having a second input connected to an output of said low pass filter; and
 a digital demodulator having an input connected to an output of said analog-to-digital converter.

14. The error reducer of claim **13**, wherein an output of said digital demodulator is proportional to rotation rate.

15. A vibration rectification error reducer for a fiber optic gyroscope, comprising:

a light source;
 a first splitter having a first port connected to an output of said light source;
 a second splitter having a first port connected to a second port of said first splitter;
 an optical fiber coil having a first end connected to a second port of said second splitter and a second end connected to a third port of said second splitter;
 a detector having an optical input connected to a third port of said first splitter; and
 an analog-to-digital converter having a variable gain connected to an output of said detector; and
 wherein the variable gain changes in response to amplitude variations of a signal from the output of said detector.

16. The error reducer of claim **15**, further comprising means for sensing amplitude variations of the signal from the output of said detector, having a frequency within a vibration frequency spectrum and for outputting a signal to said analog-to-digital converter having the variable gain vary a gain of said analog-to-digital converter in response to the amplitude variations of the signal from the output of said detector.

17. A vibration rectification error reducer for a fiber optic gyroscope, comprising:

a light source;
 a first splitter having a first port connected to said light source;
 a second splitter having a first port connected to a second port of said first splitter;
 an optical fiber coil having a first end connected to a second port of said second splitter and a second end connected to a third port of said second splitter, for conveying counter-propagating light waves;
 a phase modulator proximate to the third port of said second splitter;

a detector having an input connected to a third port of said first splitter;
 an analog-to-digital converter having an input connected to an output of said detector;
 a bias modulation source connected to an input of said phase modulator, having an output that causes a periodic phase difference modulation between the counter-propagating light waves;
 first means having a first input connected an output of said analog-to-digital converter and a second input connected to the output of said bias modulation source, for providing at an output a signal representing differences of amplitudes of a signal at the output of said analog-to-digital converter during adjacent half-cycles of periods of the periodic phase difference modulation;
 second means having a first input connected to the output of said analog-to-digital converter and a second input connected to the output of said bias modulation source, for providing at an output a signal representing an average over at least one cycle of the signal at the output of said bias modulation source of the amplitudes of the signal at the output of said analog-to-digital converter for adjacent half-cycles of the periods of the periodic phase difference modulation; and
 third means having first and second inputs connected to the outputs of said first and second means, respectively, for normalizing the signal at the output of said first means by the signal at the output of said second means to compensate for rotation rate signal variation caused by vibration.

18. The error reducer of claim **17**, wherein the normalizing of said third means comprises multiplying the signal at the output of said first means by an inverse of the signal at the output of said second means.

19. A vibration rectification error reducer for a fiber optic gyroscope, comprising:

a light source;
 a first splitter having a first port connected to an output of said light source;
 a second splitter having a first port connected to a second port of said first splitter;
 an optical fiber coil having a first end connected to a second port of said second splitter and a second end connected to a third port of said second splitter;
 a detector having an optical input connected to a third port of said first splitter;
 a variable-gain analog-to-digital converter connected to an output of said detector; and
 means for sensing amplitude variations of the signal from the output of said detector, having a frequency within a vibration frequency spectrum and for outputting a signal to said variable-gain analog-to-digital converter to vary a gain of said analog-to-digital converter in response to the amplitude variations of the signal from the output of said detector.