



US005939142A

# United States Patent [19]

[11] Patent Number: **5,939,142**

Comiskey et al.

[45] Date of Patent: **Aug. 17, 1999**

[54] **REFLECTED LIGHT GLARE MINIMIZATION FOR ATHLETIC CONTEST PARTICIPANTS WHILE PROVIDING A NON-VERBAL COMMUNICATION**

4,957,124	9/1990	Mooney	132/200
5,186,190	2/1993	Hirzel	132/319
5,816,269	10/1998	Mohammed	132/319

### OTHER PUBLICATIONS

[75] Inventors: **Stephen W. Comiskey**, Washington, D.C.; **Barrett O. Comiskey**, Cambridge, Mass.

Mueller "No Glare™ Strips" packaging, 1994. Sports Illustrated magazine, Jan. 10, 1994 issue, front cover. Three exemplary Temporary Tattoo sheets copyright 1993, produced by J.B. Marketing, Inc.

[73] Assignee: **Stephen W. Comiskey**, Washington, D.C.

"Game Faces" 1993 color brochure, Team Dynamics, Inc. J.B. Marketing, Inc. 1993 color advertising brochures and flyers.

[21] Appl. No.: **08/240,895**

"Anderson's" 1993-1994 color catalog, front cover, rear cover, pp. 61 through 63.

[22] Filed: **May 11, 1994**

*Primary Examiner*—Marie Yamnitzky  
*Attorney, Agent, or Firm*—Nixon & Vanderhye P.C.

[51] **Int. Cl.**<sup>6</sup> ..... **B05D 5/00**; B05D 1/32

[52] **U.S. Cl.** ..... **427/256**; 427/282; 427/322; 427/331; 427/401; 427/155; 428/913; 428/914

### [57] ABSTRACT

[58] **Field of Search** ..... 428/196, 199, 428/207, 211, 537.5, 542.2, 913, 914; 427/1, 282, 155, 256, 322, 331, 401; 128/858

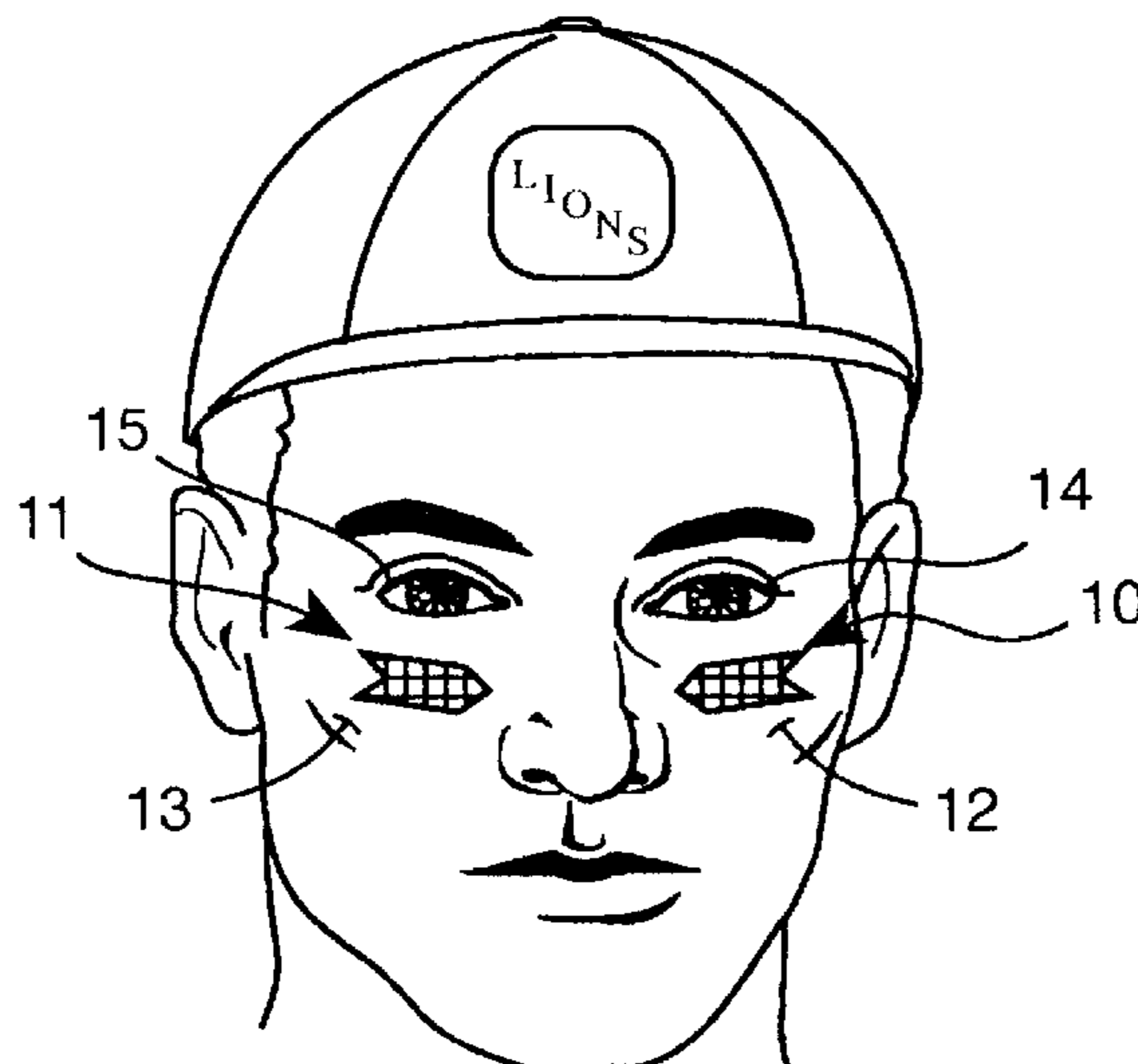
A method and product for reducing reflected light glare into a human's eyes from the human's cheeks while simultaneously providing a non-verbal communication to others is provided, especially for use by participants in athletic contests. Underneath the human's eyes on the cheeks at a reflective location on the cheeks at which incident direct or indirect light is likely to be reflected into a human's eyes a non-toxic, non-reflective colored and finished material in the form of a predefined clearly demarcated geometric shape is applied. Within a week after the application (typically within less than a few hours after the athletic contest is over) the non-reflective material is removed. The non-reflective material may comprise eye black, applied using a stencil, or it may comprise a temporary tattoo or decal, applied in the conventional manner. The shape preferably is a sports apparel or equipment manufacturer's or distributor's logo and/or letters, or a team name, mascot or logo. The material is preferably black or dark colored, and any non-black or non-dark colored portions providing demarcation between elements of the shape comprises a dull or matte color having a wavelength of greater than about 650 nm and less than about 470 nm.

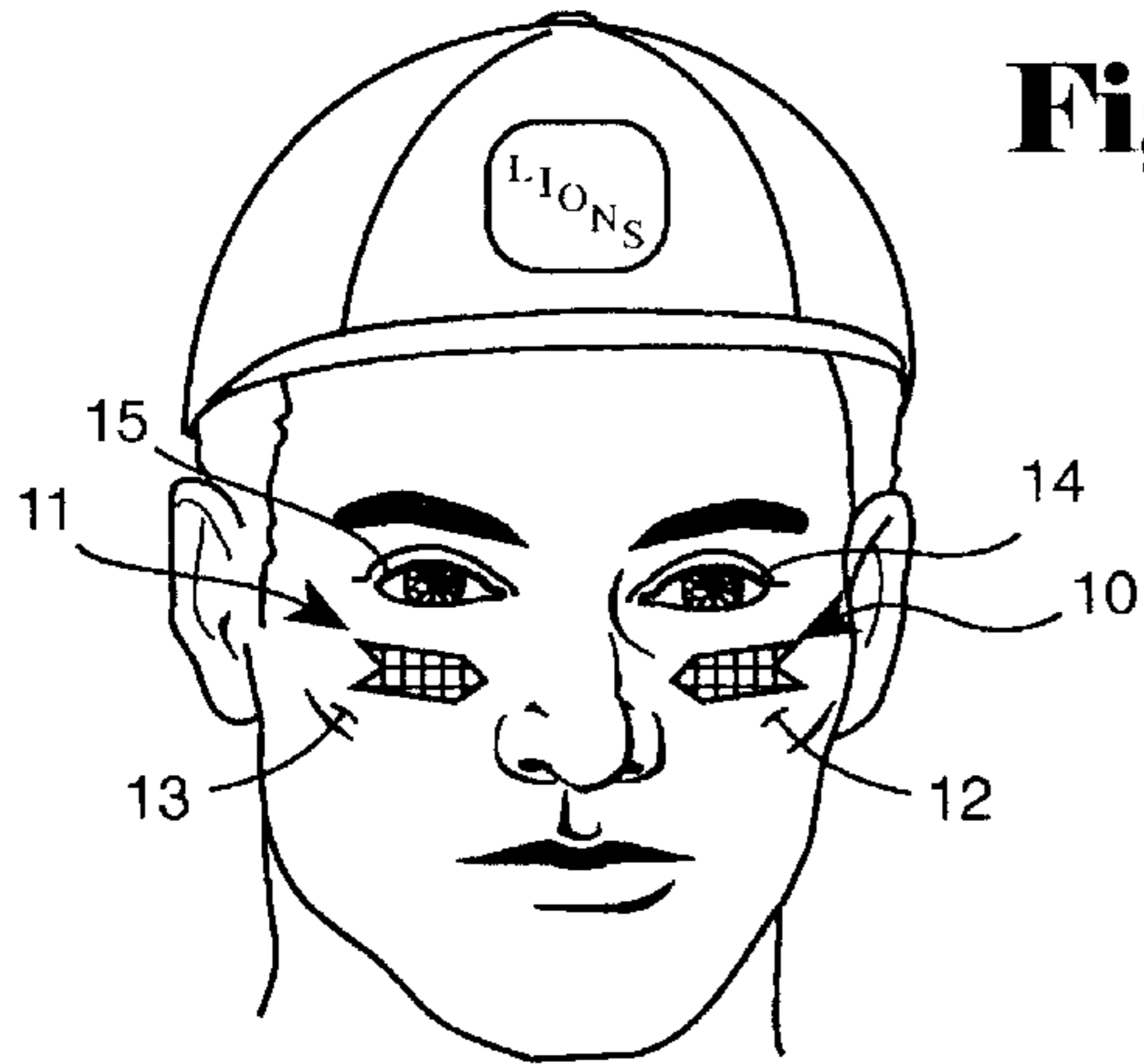
### [56] References Cited

#### U.S. PATENT DOCUMENTS

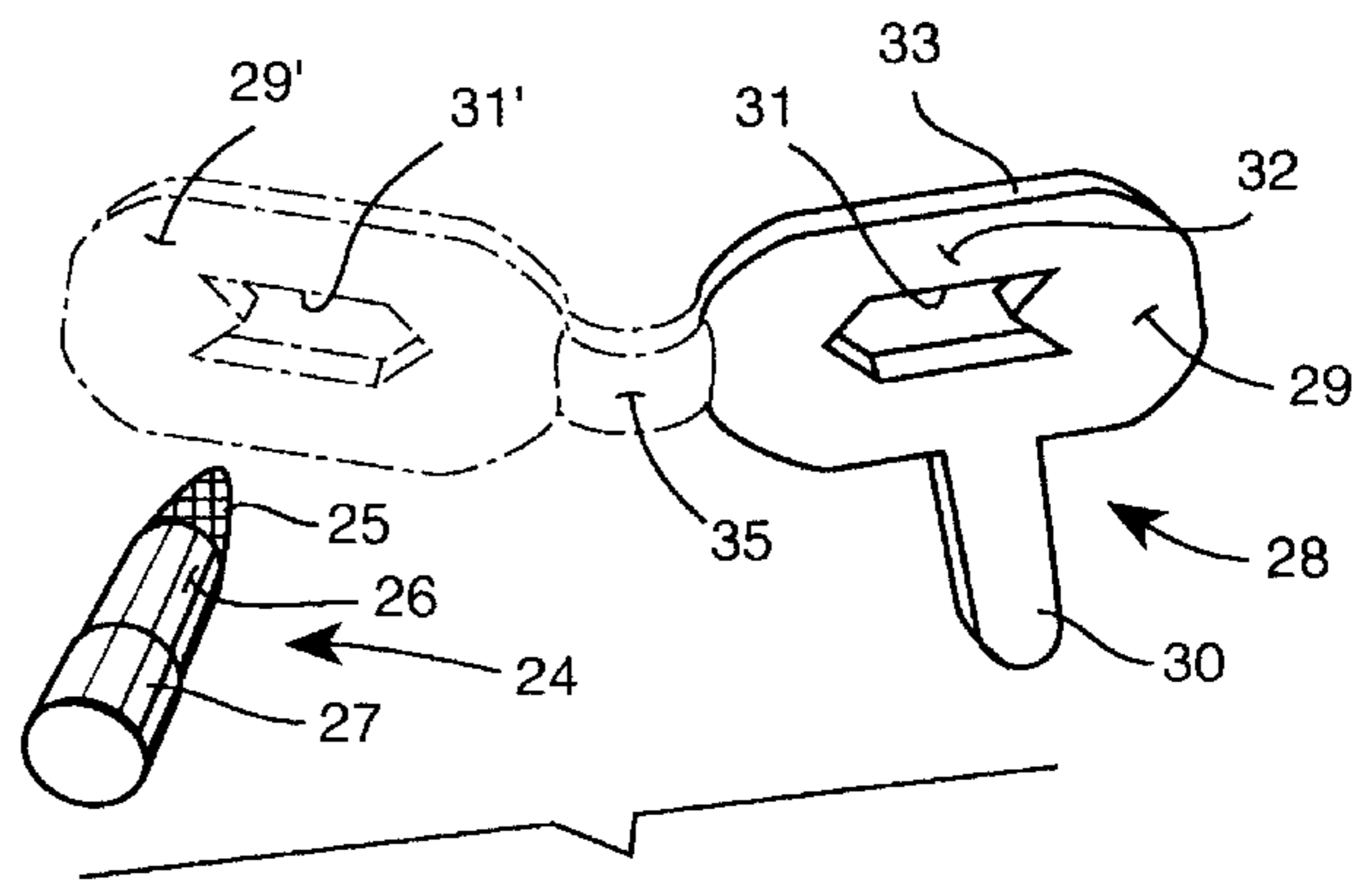
1,627,407	5/1927	Reese .	
1,803,836	5/1931	Bihl .	
1,811,804	6/1931	Poschel .	
2,578,150	12/1951	Rathke .	
2,941,916	6/1960	Akkeron .	
3,681,186	8/1972	Findlay et al. .	
3,898,357	8/1975	Miller et al. ....	428/42
4,060,643	11/1977	Blanks	428/195
4,105,483	8/1978	Lin	156/154
4,115,602	9/1978	Bullard	427/140
4,169,169	9/1979	Kitabatake	427/149
4,175,151	11/1979	Eppich et al. ....	428/202
4,522,864	6/1985	Humason et al. ....	428/201
4,594,276	6/1986	Relyea	428/40
4,674,133	6/1987	Oschner	2/206
4,719,909	1/1988	Micchia et al. ....	128/156
4,745,916	5/1988	Seber	128/155
4,783,350	11/1988	DeMatteo et al. ....	428/16
4,936,325	6/1990	Davis	132/319

**18 Claims, 3 Drawing Sheets**

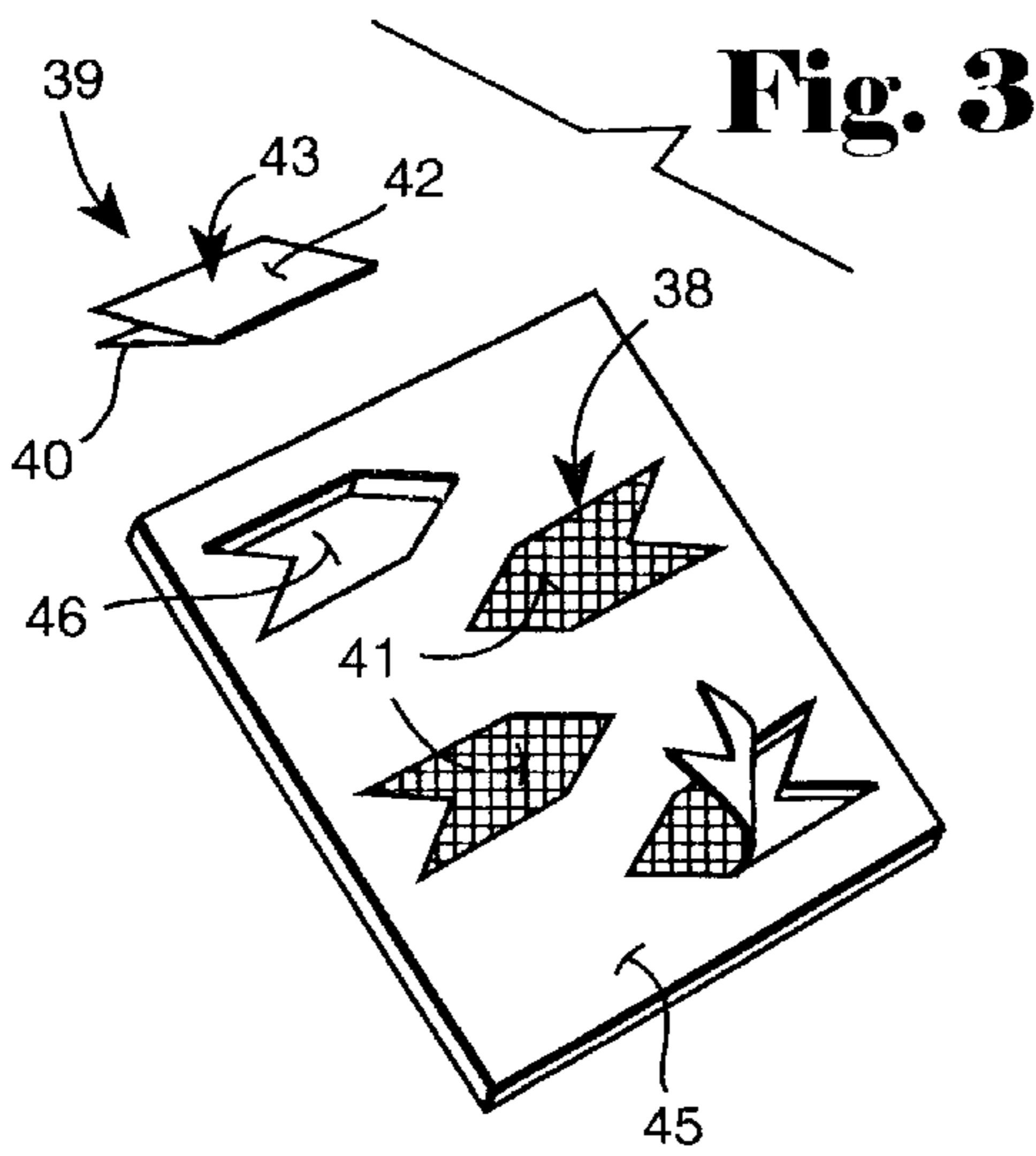




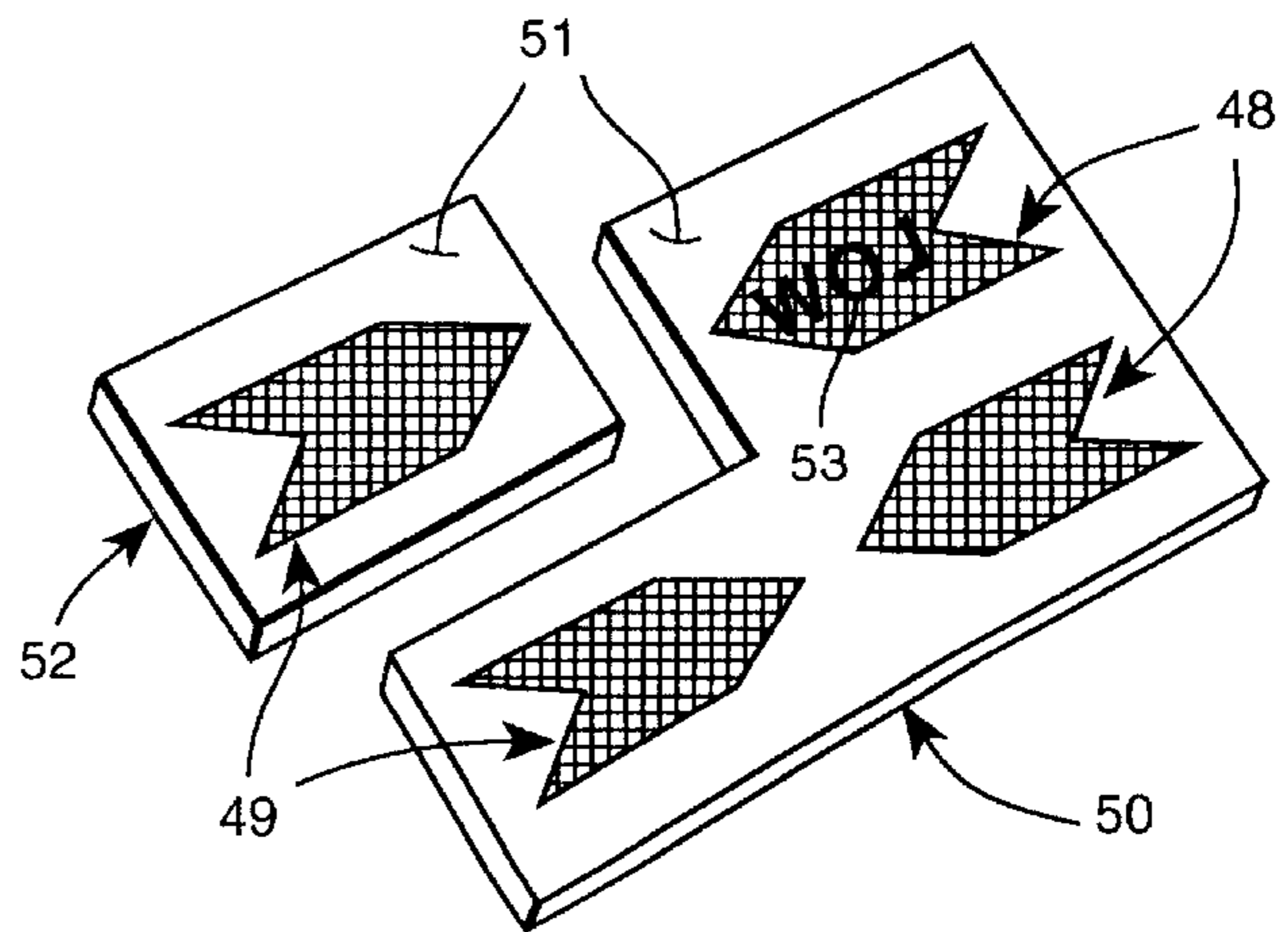
**Fig. 1**



**Fig. 2**

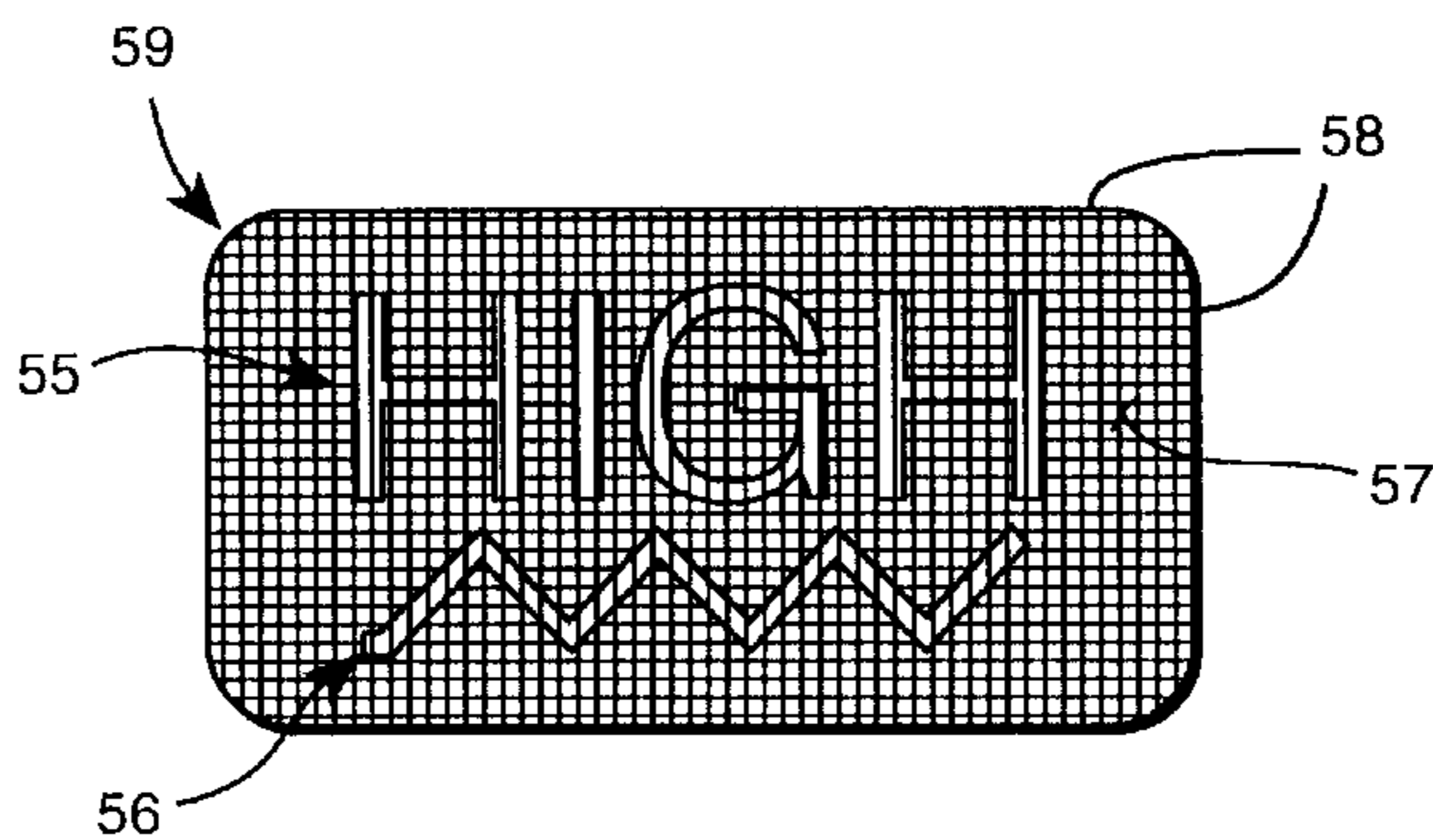


**Fig. 3**

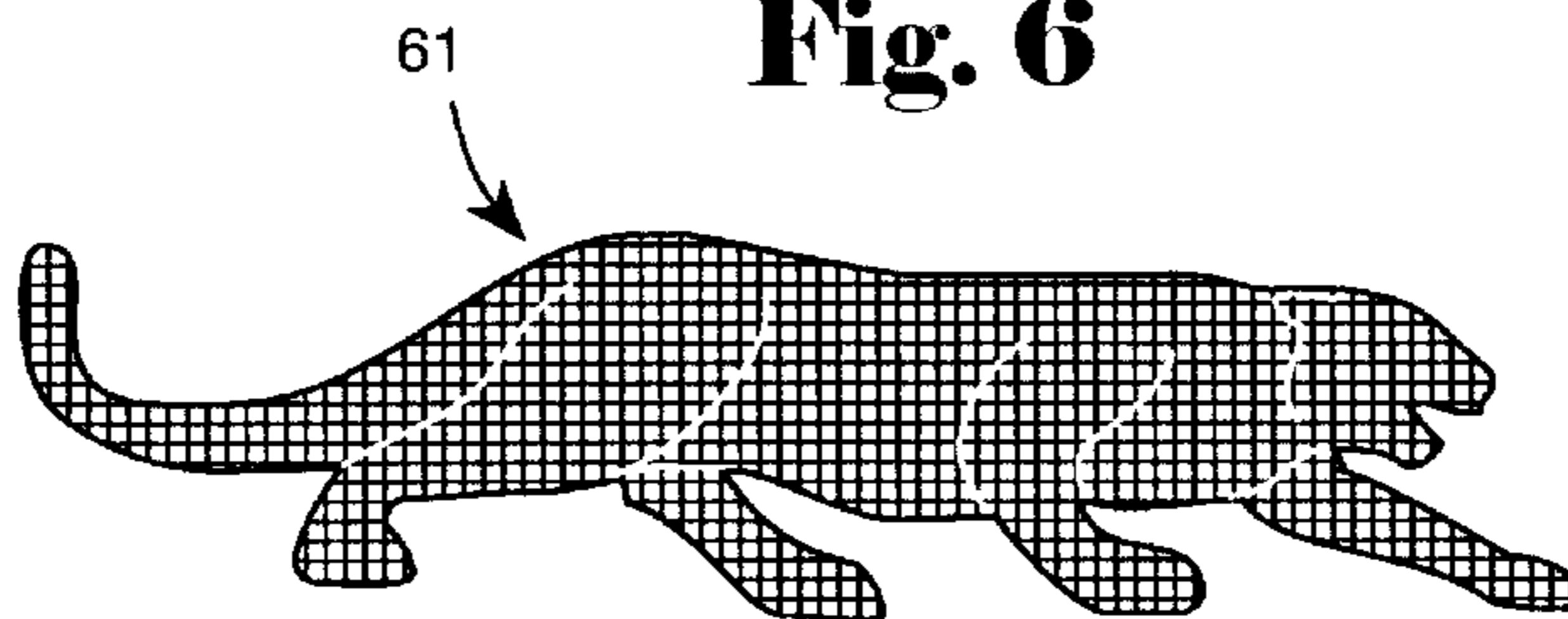


**Fig. 4**

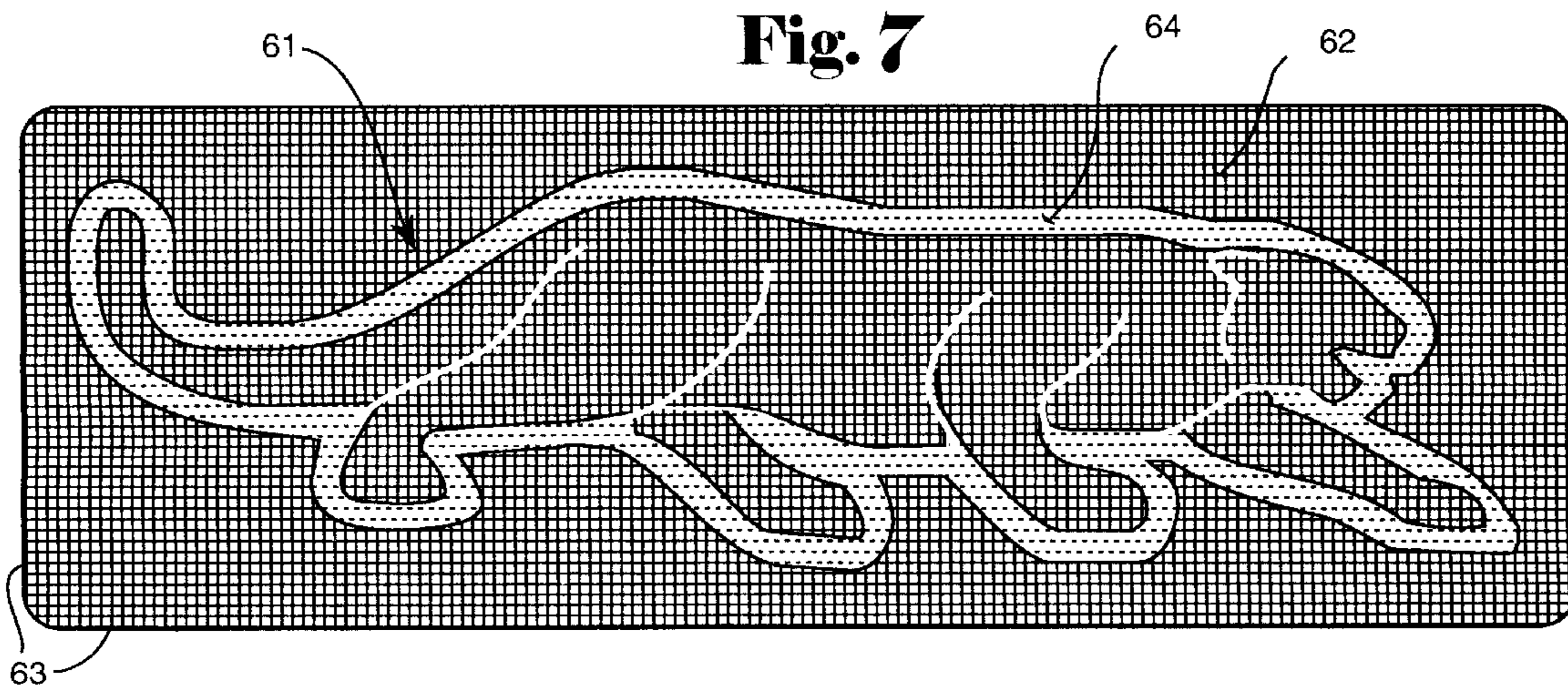
**Fig. 5**



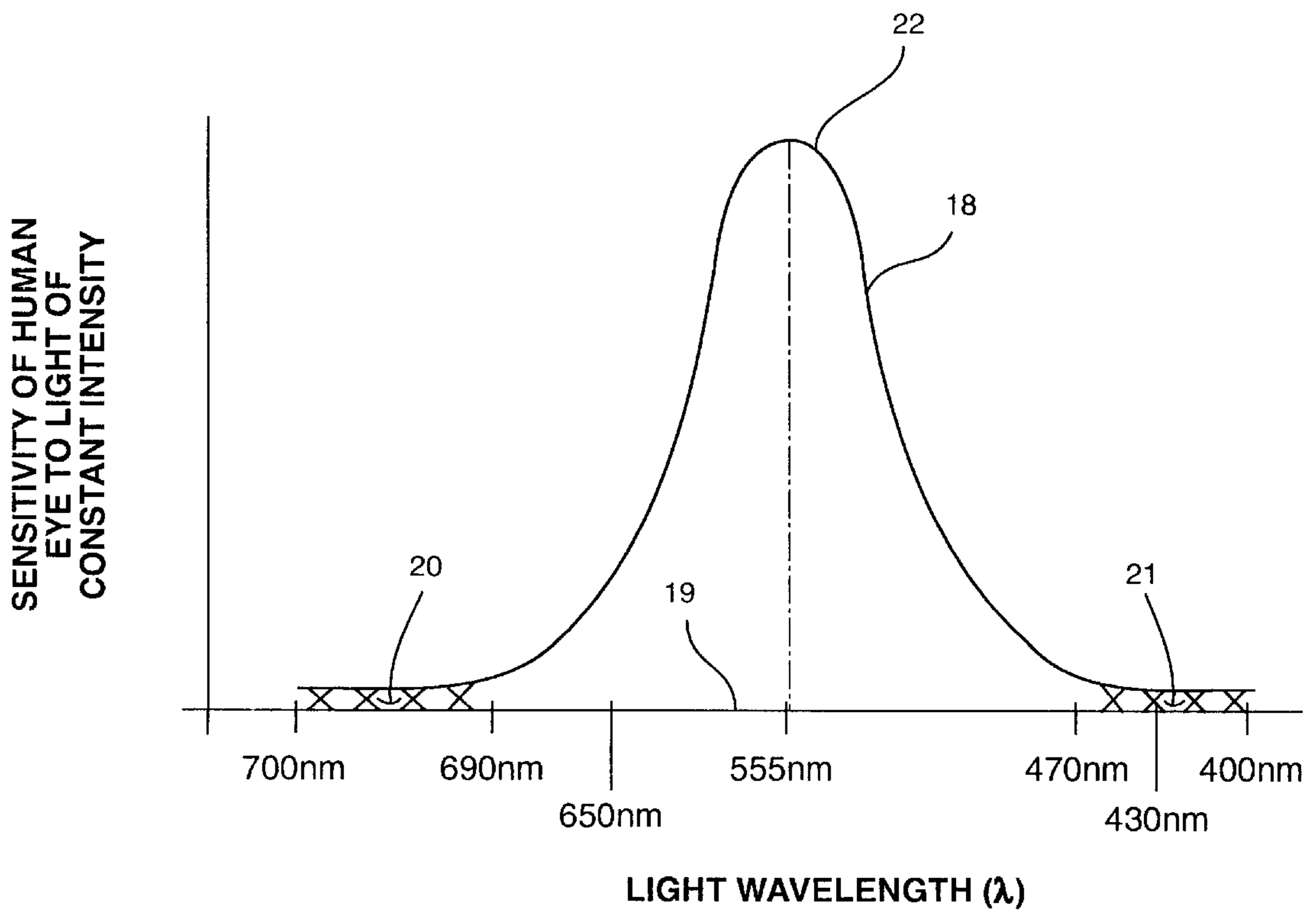
**Fig. 6**



**Fig. 7**



**Fig. 8**



**REFLECTED LIGHT GLARE  
MINIMIZATION FOR ATHLETIC CONTEST  
PARTICIPANTS WHILE PROVIDING A NON-  
VERBAL COMMUNICATION**

**BACKGROUND AND SUMMARY OF THE  
INVENTION**

Participants in athletic contests, particularly participants in team sports such as football, soccer, baseball, and lacrosse, that are played outside during the day, or in well lit stadiums, minimize the light that is reflected from their cheeks into their eyes by applying conventional eye black to their cheeks. Conventional eye black typically includes as ingredients Vaseline, lanolin, ceresin wax, beeswax, carnauba wax, and black oxide of iron C177499UV. Eye black may be applied with a finger by dipping it into a large container and wiping on the cheeks under the eye, or applied with a marker in much the same form that lipstick is applied.

In the promotion of sports apparel and equipment by apparel or equipment manufacturers or distributors, there is intense competition and one of the major ways that such companies promote their products is by having their products used by participants in high visibility athletic contests, especially those that are televised. For example the larger shoe manufacturers in the world have millions of dollars of endorsement contracts with teams, sports leagues, and individual players to promote their products through players wearing equipment such as shoes, shirts, wrist bands, or the like, having the logo of the manufacturer or distributor thereon.

Another product market area also usually associated with athletics, but also used for other purposes, are the supply and sale of decals or temporary tattoos having team names, logos, mascots, slogans, and the like. The decals and temporary tattoos are made to be bright and/or reflective and can be applied on different parts of the body, although the manufacturers often caution against applying them near the eyes or on sensitive skin, often because the products are widely used by children.

According to the present invention, a method and products are provided which utilize and simulate concepts from each of the three heretofore distinct art areas described above, providing a method and product by which participants in athletic contests can accomplish the functional task of reducing reflected light glare into their eyes while at the same time advertising a sports apparel or equipment manufacturer's or distributor's logo and/or name, or providing a like non-verbal communication to others. According to the present invention eye black, or temporary tattoos or decals having basically the same non-reflective properties as eye black, are applied underneath the eyes in the form of a predefined clearly demarcated geometric shape which provides a non-verbal communication to others. Unlike conventional temporary tattoos and decals, the geometric shape according to the invention is non-reflective, typically as a dull or matte black or other dark color having a wavelength greater than about 690 nm and less than about 430 nm. It is non-reflective in the sense that it reflects very little light from the visible spectrum and, therefore, appears dull or matte. Unlike conventional eye black, the material is applied in a clearly demarcated shape which—rather than being a blob or streak, provides a non-verbal communication to others, such as an advertisement for a sports apparel or equipment manufacturer or distributor, or a team name, mascot or logo.

According to one aspect of the present invention, a method of reducing reflective light glare into a human's eyes

from the human's cheeks while simultaneously providing a non-verbal communication to others is provided. The method comprises the steps of: (a) Applying underneath the human's eyes, on the human's cheeks, generally covering a reflective location on the cheeks, at which incident direct or indirect light is likely to be reflected into the human's eyes, a non-toxic material having a non-reflective colored and finished exterior in the form of a predefined clearly demarcated geometric and predefined shape which provides a non-verbal communication to others. And, (b) within a week after application of the non-reflective material from step (a), removing it. Typically the human is a participant in an athletic contest, in which case step (a) is practiced within a few hours or less before the start of the athletic contest and so that the material substantially eliminates reflection of incident direct or indirect light off the participant's cheeks into the participant's eyes, and step (b) is practiced within a few hours or less after the athletic contest is over.

Steps (a) and (b) as set forth above may be practiced in a number of different ways. According to one particular aspect of the invention, step (a) is practiced by placing a stencil underneath one of the human's eyes and over the reflective location on a cheek, the stencil having a cutout of the clearly demarcated geometric and predefined shape, and then applying eye black to the cheek reflective location under the cutout, and then removing the stencil; and wherein step (b) is practiced by wiping off the eye black, or washing it off with soap and water, or both wiping it off and washing it off. Step (a) further may be practiced by repeating the steps of claim 3 for the other of the human's eyes.

According to another aspect of the invention, the material is a decal comprising a substrate, having top and bottom faces, the top face of the decal being the non-reflective material, and the bottom face of the decal having a pressure sensitive adhesive thereon; and in which case step (a) is practiced by applying the bottom face of the decal to the reflective cheek portion and pressing so that the adhesive holds the decal in place.

According to yet another aspect of the invention, the material is a temporary tattoo, provided on a backing, the temporary tattoo provided on a top face of the backing and illustrating the reverse of the clearly demarcated geometric and predefined shape, and the backing having a bottom face; and in which case step (a) is practiced by cleaning a cheek where the temporary tattoo is to be applied, putting the temporary tattoo on the top face of the backing on the reflective location of the human's cheek to which it is to be applied, wetting the bottom face of the backing with water and pressing it into contact with the cheek for sufficient time for the temporary tattoo to adhere to the cheek, and sliding off the backing from the temporary tattoo. Step (b) is typically practiced by rubbing the temporary tattoo off using alcohol or baby oil, or applying tape thereto and then pulling off the tape.

Regardless of the details of practicing the invention as described above, step (a) is preferably practiced to provide as the clearly demarcated geometric and predefined shape a sports apparel or equipment manufacturer's or distributor's logo, the logo having a size complying with regulations of a regulatory body which oversees the athletic contest. Further, the geometric shape may include letters instead of or in addition to the logo, with a primarily black or dark colored area sized to comply with the regulatory body's standards, and with the letters or any demarcation between any letters in the primarily black or dark colored area comprising a dull or matte color and absorbing most of the light in the visible spectrum. Alternatively the clearly demar-

cated geometric and predefined shape may comprise a representation of a sports team name, mascot or logo. In some cases the logo (whether commercial or sports team) may have a directional bias and step (a) of the method described above may be practiced by applying the logo with the correct directional bias under one of the human's eyes, and with the reverse of the correct directional bias under the other of the human's eyes; or the logo may have the correct directional bias under both the human's eyes.

According to another aspect of the present invention a decal or temporary tattoo having a clearly demarcated geometric and predefined shape and dimensioned to substantially cover the area on a human's cheek underneath one of the human's eyes is provided. The decal or temporary tattoo comprises: A clearly demarcated geometric and predefined shape dimensioned to substantially cover the area of a reflective location on a human's cheek at which incident direct or indirect light is likely to be reflected into the human's eye, the temporary tattoo or decal being non-toxic and having an exterior, when applied, surface of non-reflective colored and finished material sufficient to substantially eliminate the reflection of incident direct or indirect light off the human's cheek into the human's eye. Desirably, the clearly demarcated geometric and predefined shape is a sports apparel or equipment manufacturer's or distributor's logo and/or letters identifying the manufacturer or distributor, no part of the shape that is not a dull or matte black or dark color having a size significant enough to allow significant reflection of incident direct or indirect light off the human's cheeks into the human's eyes. For example, the clearly demarcated geometric and predefined shape may consist of a sports apparel or equipment manufacturer's or distributor's logo and/or letters, and a clearly demarcated shape will have a size complying with the regulations of any regulatory body which oversees the participants in an athletic contest by whom the decal or temporary tattoo is utilized.

According to yet another aspect of the present invention an eye black clearly demarcated geometric and predefined shape is provided produced according to the method as described above wherein a particular design is stenciled under a user's eyes using eye black.

It is the primary object of the present invention to provide a method and apparatus for simultaneously reducing reflective light glare into a human's eyes from the human's cheeks while simultaneously providing a non-verbal communication to others in a simple and effective manner, particularly one that lends itself to commercial advertisement or sports team promotion. This and other objects of the invention will become clear from an inspection of the detailed description of the invention, and from the appended claims,

#### BRIEF DESCRIPTION OF THE DRAWINGS

FIG. 1 is a front schematic view of an athletic contest participant having non-reflective material applied under his or her eyes in a clearly demarcated geometric and predefined shape in accordance with the present invention;

FIG. 2 is a schematic perspective view showing an exemplary stencil, and eye black marker, that can be used to apply the logo illustrated in FIG. 1;

FIG. 3 is a schematic perspective view of exemplary decals that may be utilized according to the present invention to apply the logos illustrated in FIG. 1;

FIG. 4 is a view like that of FIG. 3 only showing temporary tattoos;

FIG. 5 is another exemplary form that the predefined clearly demarcated geometric shape according to the invention can take;

FIGS. 6 and 7 are views like that of FIG. 5 only for other embodiments according to the invention; and

FIG. 8 is a schematic graphical representation of the sensitivity of a human's eyes to light of constant intensity plotted against light wavelength.

#### DETAILED DESCRIPTION OF THE DRAWINGS

FIG. 1 schematically illustrates clearly demarcated geometric and predefined shapes **10** and **11** according to the present invention which are applied to generally cover a reflective location on each of the cheeks **12**, **13** of a human, such as a participant in an athletic contest. The reflective locations on the cheeks **12**, **13** are those at which incident direct or indirect light is likely to be reflected into the human's eyes **14**, **15**. The shapes **10**, **11** are applied at the same location that conventional eye black is applied. This location is not scientifically precise or uniform from person to person since it may depend upon the person's facial contours, but for most participants in outdoor or brightly lighted athletic facilities, particularly participants in team sports using a ball (such as football, soccer, baseball, lacrosse, etc.), it is applied about one-quarter to three-quarters of an inch under the participant's eyes (e.g. starting at the bottom of the eye socket) and continuing downwardly about a half inch to an inch, and extending in width generally the width of the eye **14** or **15** (or slightly more or less). In the embodiment illustrated in FIG. 1, the shapes **10**, **11** are a fictional sports apparel or equipment manufacturer's or distributor's logo (**10**) and a reverse image of the logo (**11**), although the logo itself (**10**), rather than the reverse image (**11**), may be provided under both eyes **14**, **15**.

The shapes **10**, **11** are of a non-toxic material (although care still must be taken not to get the material or any component thereof into the eyes **14**, **15** since at least temporary discomfort will result) having a non-reflective colored and finished exterior. The non-reflective colored and finished exterior preferably has characteristics comparable to conventional eye black (typically a mixture and gel of semi-solid form of Vaseline, lanolin, ceresin wax, beeswax, carnauba wax, and black oxide of iron C177499UV). That is it is dull or matte, rather than shiny or glossy, and is black and/or of other non-reflective colors. With particular reference to FIG. 8 which is a schematic graphical representation of the sensitivity of the human eye for light of constant intensity (plotted on the Y axis) versus light wavelength (plotted on the X axis) for the range of human visibility, typically the colors utilized according to the invention for the exterior of the shapes **10**, **11** comprise colors having a wavelength greater than about 650 nm (middle of red) and less than about 470 nm (all of blue and violet), and preferably greater than about 690 nm and less than about 430 nm. The full range of human sensitivity is not well defined, varying from person to person, because—as illustrated in FIG. 8—the eye sensitivity curve **18** approaches the zero sensitivity line (X axis) **19** asymptotically. Typical limits include about 700 nanometers (nm) for red and about 400 nanometers for violet. The approximate values 690 nanometers and 430 nanometers, which define the shaded areas **20**, **21** in FIG. 8, are provided where eye sensitivity has dropped to one percent of the maximum value at point **22** (typically at about 555 nm). The colors in area **20** range from deep reds to blacks while the colors in area **21** range from deep violets to blacks.

While it is highly preferable for maximum utility of the shapes **10**, **11** that no colors except as described above are provided, where functionality can be compromised slightly,

or where functionality is not the primary purpose for utilizing the shapes **10**, **11**, some white or brighter colors can be utilized to provide demarcation, or less than the entire conventional reflective area on the cheeks **12**, **13** under the eyes **14**, **15** may be covered by the shapes **10**, **11**. However in no case should shiny or glossy exterior surfaces of the shapes **10**, **11** be provided, nor should large or continuous areas of white or bright colors.

FIG. **2** illustrates apparatus that may be utilized in the practice of the method of the present invention. A conventional eye black marker **24**, having a stick of eye black **25** that is movable in and out of the conventional lipstick style container **26** by rotation of the end portion **27** thereof is provided for use in association with a stencil or mask **28**. The stencil or mask assembly **28** may comprise a simple stencil **29**, e.g. having an extension **30** for easy gripping by the user, and having a cut out **31** formed therein corresponding to the shape **10** or the shape **11**. The stencil **29** may also have a centering mark **32** thereon for centering the cut out **31** underneath an eye **14**, **15**, and the spacing between the top edge **33** of the stencil and the first portion of the cut out **31** may be dimensioned so that the top edge **33** is placed underneath the eye **14**, **15** during use so that the cut out **31** is at a position whereby eye black **25** may be safely and functionally applied on the cheek **12** or **13**. If desired, instead of a simple stencil **29** the stencil assembly **28** may also include a nose piece **35** and a second stencil **29'** on the opposite side of the nose piece **35** from the stencil **29**. The cut out **31'** provided therein (which is either identical to the cut out **31** or the reverse thereof) so that both cheeks **12**, **13** can be done at the same time.

The eye black **25**, when it is desired to be removed (e.g. typically a few minutes after an athletic contest, and certainly within a few hours after), is removed in the same manner that eye black is conventionally removed. That is it may be wiped off, washed off with soap and water, or both.

FIG. **3** illustrates alternative products that may be utilized to practice the method of the present invention, which products are also an aspect of the present invention. The products of FIG. **3** comprise decals **38**, **39** of basically conventional construction (e.g. such as shown in U.S. Pat. Nos. 3,898,357 or 4,522,864) which comprise a substrate having a top face **41** and a bottom face **42**. The bottom face **42** has a pressure sensitive adhesive thereon as illustrated schematically at **43** in FIG. **3**, while the top face **41** comprises an exterior surface (during use) of a non-reflective colored and finished material described earlier. That is—as illustrated in FIG. **3**—the surface **41** may be solid dull black, with or without lettering. As is conventional, the decals **38**, **39** can be peeled off a supporting sheet assembly **45** from which the decals **38**, **39** have been die-cut, being held in place before use with the adhesive **43** in contact with a release sheet **46** comprising the bottom substrate of the sheet assembly **45**. The decals **38**, **39** are applied merely by pressing them with the pressure sensitive adhesive **43** into contact with the cheeks **12**, **13** so that they are held in place against the skin by the adhesive **43**. To remove them one need simply peel off part of an edge of one of the decals **38**, **39** from the skin, and pull.

FIG. **4** illustrates other products according to the present invention utilizable in practicing the method of the present invention. In FIG. **4** conventional temporary tattoos **48**, **49** are illustrated, the tattoos having the shapes **10**, **11**. The temporary tattoos **48**, **49** are provided on a substrate **50**, i.e. on top face **51** thereof, and are the reverse of the clearly demarcated geometric shape desired. That is the temporary tattoos **48** will provide the shapes **11** and the temporary

tattoos **49** the shapes **10**. As is conventional for the use of temporary tattoos, a section of the substrate **50** containing one of the tattoos (**49**) is cut out from the rest of the substrate **50**, as illustrated for the cut out portion **52** in FIG. **4**. After the cheek **12** to which it is applied has been cleaned so that it is free of oils, dirt, etc. the temporary tattoo **49** is put on the cheek **12**, the bottom face (not shown) of the substrate **50** is wet (typically with water) and the substrate section **52** is pressed on so that the temporary tattoo **49** is in contact with the cheek **12** a sufficient time for the temporary tattoo **49** to adhere to the cheek, at which point the substrate portion **52** is slid off from the temporary tattoo **49** which adheres to the cheek **12**. While conventional temporary tattoos last about three to five days, in most circumstances according to the invention it will be desirable to remove the temporary tattoo **48**, **49** shortly after an athletic contest. Removal may be accomplished, as is conventional, using rubbing alcohol or baby oil which is applied and rubbed on the tattoo **48**, **49**, or by using pressure sensitive adhesive tape, the adhesive on the tape being applied to the temporary tattoo **48**, **49** and being removed when the tape is removed.

FIG. **4** also illustrates for the upper of the temporary tattoos **48** another embodiment according to the invention. In this embodiment words are provided within the tattoo **48**. The words—in the embodiment illustrated in FIG. **4** the single word “Low” which is a fictional name of a sports apparel or equipment manufacturer or distributor, such as a sports shoe manufacturer—is provided within the logo of that same manufacturer or distributor, as illustrated at **53**. The word “Low” is illustrated in reverse in FIG. **4** since when it is applied as the shape **11** the letters will be mirror image. In order to maintain optimum functionality of the temporary tattoo **48** for preventing reflection of light into the human’s eyes, the letters making up the word **53** are preferably of a red or a blue or violet, or there are red or blue or violet demarcation lines between it and the black of the body of the tattoo **48**. Where optimum functionality is not critical, however, the word **53** may be of a clearer contrasting color to black than red or blue or violet, or it may have demarcation lines around the word **53** of a clearer contrasting color.

FIG. **5** illustrates another exemplary construction according to the invention. In this construction a decal is illustrated (although it could as easily be a tattoo, or even possibly a stencil image depending upon the details of what is illustrated therein). In this case clearly demarcated predefined geometric shapes are formed of a fictional sports apparel or equipment manufacturer’s or distributor’s name **55** and logo **56**, within a primarily black or dark color surrounding area **57**, also having predefined borders **58**. The letters **55** and logo **56** are sized so as to comply with regulations of any regulatory body which oversees the athletic contest in which a participant utilizing the decal **59** will be participating (typically as a player or referee). For example if the contest is an NCAA sanctioned contest then the words **55** and logo **56** must fit within an area that is one and one-half inch square. Where optimum functionality is desired, the letters **55** and logo **56**, or any demarcation between them and the surrounding primarily black area **57**, are of a dull or matte color having a wavelength greater than about 650 nm and less than about 470 nm (preferably greater than about 690 nm and less than about 430 nm). Where optimum functionality is not required, and/or where the areas covered by the elements **55**, **56** are small enough or discontinuous enough, a clearer contrasting (to the black or dark colored area **57**) color may be utilized.

FIGS. **6** and **7** illustrate additional embodiments according to the invention. In FIG. **6** an exemplary team mascot—a

black panther—is illustrated which may be stenciled on with eye black, or applied in decal or temporary tattoo form as long as the color thereof is dull or matte (not reflective). FIG. 7 illustrates the same mascot configuration 61 from FIG. 6 but within a surrounding background 62 having predefined clearly demarcated edges 63, with the mascot 61 demarcated from the surrounding black or dark colored area 62 by lines 64. The lines 64 preferably are a dull or matte color having a wavelength greater than about 690 nm and less than about 430 nm, but again where optimum functionality is not required may be of a clearer contrasting non-reflective color. The embodiment of FIG. 7 is typically more functional than the embodiment of FIG. 6 since the surrounding area 62 can be dimensioned for optimum functionality for minimizing light reflection into the user's eyes, whereas the mascot shape 61 per se may or may not properly cover the appropriate reflective portion of the cheeks 12, 13.

It will thus be seen that according to the present invention a highly advantageous yet simple method and products are provided for simultaneously reducing reflective light glare into a human's eyes from the human's cheeks while simultaneously providing a non-verbal communication to others. While the invention has been herein shown and described in what is presently conceived to be the most practical and preferred embodiment thereof it will be apparent to those of ordinary skill in the art that many modifications may be made thereof within the scope of the present invention, which scope is to be accorded the broadest interpretation of the appended claims so as to encompass all equivalent processes and products.

What is claimed is:

1. A method of reducing reflected light glare into a human's eyes from the human's cheeks while simultaneously providing a non-verbal communication to others, wherein the human is a participant in an athletic contest, comprising the steps of:

- (a) within a few hours or less before the start of the athletic contest, applying underneath the human's eyes, on the human's cheeks, covering a reflective location on the cheeks at which incident direct or indirect light is likely to be reflected into the human's eyes, a non-toxic material having an exterior surface appearing as a dull or matte color having a wavelength of greater than 690 nm and less 430 nm, in the form of a predefined clearly demarcated geometric shape which provides a non-verbal communication to others; and
- (b) within a few hours or less after the athletic contest is over, removing the non-toxic material; and

wherein step (a) is practiced by placing a stencil underneath one of the human's eyes and over the reflective location on a cheek, the stencil having a cutout of the clearly demarcated geometric and predefined shape, and then applying eye black to the cheek reflective location under the cutout, and then removing the stencil; and wherein step (b) is practiced by wiping off the eye black, or washing it off with soap and water, or both wiping it off and washing it off.

2. A method as recited in claim 1 which is further practiced by repeating the steps of claim 1 for the other of the human's eyes.

3. A method as recited in claim 1 wherein step (a) is practiced to provide as the clearly demarcated predefined geometric shape a sports apparel or equipment manufacturer's or distributor's logo and/or letters identifying the manufacturer or distributor within a primarily black or dark colored area, and sized to comply with regulations of any regulatory body which oversees the athletic contest.

4. A method as recited in claim 1 wherein step (a) is practiced to provide as the clearly demarcated geometric and predefined shape a representation of a sports team name, mascot or logo.

5. A method as recited in claim 1 wherein step (a) is practiced to provide as the clearly demarcated geometric and predefined shape a sports apparel or equipment manufacturer's or distributor's logo and/or letters identifying the manufacturer or distributor.

6. A method as recited in claim 5 wherein step (a) is further practiced to apply a logo having a directional bias, and by applying the logo with the correct directional bias under one of the human's eyes, and with the reverse of the correct directional bias under the other of the human's eyes.

7. A method of reducing reflected light glare into a human's eyes from the human's cheeks while simultaneously providing a non-verbal communication to others, wherein the human is a participant in an athletic contest, comprising the steps of:

- (a) within a few hours or less before the start of the athletic contest, applying underneath the human's eyes, on the human's cheeks, covering a reflective location on the cheeks at which incident direct or indirect light is likely to be reflected into the human's eyes, a non-toxic material having an exterior surface appearing as a dull or matte color having a wavelength of greater than 690 nm and less 430 nm, in the form of a predefined clearly demarcated geometric shape which provides a non-verbal communication to others; and
- (b) within a few hours or less after the athletic contest is over, removing the non-toxic material; and

wherein the material is a temporary tattoo, provided on a substrate, the temporary tattoo provided on a top face of the substrate and illustrating the reverse of the clearly demarcated geometric and predefined shape, and the substrate having a bottom face; and wherein step (a) is practiced by cleaning a cheek where the temporary tattoo is to be applied, putting the temporary tattoo on the top face of the substrate on the reflective location of the human's cheek to which it is to be applied, wetting the bottom face of the substrate with water and pressing it into contact with the cheek for sufficient time for the temporary tattoo to adhere to the cheek, and sliding off the substrate from the temporary tattoo.

8. A method as recited in claim 7 wherein step (b) is practiced by rubbing the temporary tattoo off using alcohol or baby oil, or applying tape thereto and then pulling off the tape.

9. A method as recited in claim 7 wherein step (a) is practiced to provide as the clearly demarcated predefined geometric shape a sports apparel or equipment manufacturer's or distributor's logo.

10. A method as recited in claim 9 wherein step (a) is further practiced to apply a logo having a directional bias, and by applying the logo with the correct directional bias under one of the human's eyes, and with the reverse of the correct directional bias under the other of the human's eyes.

11. A method as recited in claim 7 wherein step (a) is practiced to provide as the clearly demarcated predefined geometric shape a sports apparel or equipment manufacturer's or distributor's logo and/or letters identifying the manufacturer or distributor within a primarily black or dark colored area, and sized to comply with regulations of any regulatory body which oversees the athletic contest, with the letters or logo, or any demarcation between any letters or logo and the primarily black or dark colored area, appearing as a dull or matte color.



12. A method as recited in claim 7 wherein step (a) is practiced to provide as the clearly demarcated geometric and predefined shape a representation of a sports team name, mascot or logo.

13. A method of reducing reflected light glare into a human's eyes from the human's cheeks while simultaneously providing a non-verbal communication to others, comprising the steps of:

(a) applying underneath the human's eyes, on the human's cheeks, covering a reflective location on the cheeks at which incident direct or indirect light is likely to be reflected into the human's eyes, a non-toxic material having an exterior surface appearing as a dull or matte color having a wavelength of greater than 690 nm and less 430 nm, in the form of a predefined clearly demarcated geometric shape which provides a non-verbal communication to others; and

(b) within a week after application of the non-toxic material from step (a), removing it; and

wherein step (a) is practiced by placing a stencil underneath one or both of the human's eyes and over the reflective location on a cheek, the stencil having a cutout of the clearly demarcated geometric and predefined shape, and then applying eye black to the cheek reflective location under the cutout, and then removing the stencil; and wherein step (b) is practiced by wiping off the eye black, or washing it off with soap and water, or both wiping it off and washing it off.

14. A method as recited in claim 13 wherein step (a) is practiced to provide as the clearly demarcated geometric and predefined shape a sports apparel or equipment manufacturer's or distributor's logo and/or letters identifying the manufacturer or distributor.

15. A method as recited in claim 14 wherein step (a) is further practiced to apply a logo having a directional bias, and by applying the logo with the correct directional bias under one of the human's eyes, and with the reverse of the correct directional bias under the other of the human's eyes.

16. A method of reducing reflected light glare into a human's eyes from the human's cheeks while simulta-

neously providing a non-verbal communication to others, comprising the steps of:

(a) applying underneath the human's eyes, on the human's cheeks, covering a reflective location on the cheeks at which incident direct or indirect light is likely to be reflected into the human's eyes, a non-toxic material having an exterior surface appearing as a dull or matte color having a wavelength of greater than 690 nm and less 430 nm, in the form of a predefined clearly demarcated geometric shape which provides a non-verbal communication to others; and

(b) within a week after application of the non-toxic material from step (a), removing it; and

wherein the material is a temporary tattoo, provided on a backing, the temporary tattoo provided on a top face of the backing and illustrating the reverse of the clearly demarcated geometric and predefined shape, and the substrate having a bottom face; and wherein step (a) is practiced by cleaning a cheek where the temporary tattoo is to be applied, putting the temporary tattoo on the top face of the backing on the reflective location of the human's cheek to which it is to be applied, wetting the bottom face of the backing with water and pressing it into contact with the cheek for sufficient time for the temporary tattoo to adhere to the cheek, and sliding off the backing from the temporary tattoo.

17. A method as recited in claim 16 wherein step (a) is practiced to provide as the clearly demarcated geometric and predefined shape a sports apparel or equipment manufacturer's or distributor's logo and/or letters identifying the manufacturer or distributor.

18. A method as recited in claim 17 wherein step (a) is further practiced to apply a logo having a directional bias, and by applying the logo with the correct directional bias under one of the human's eyes, and with the reverse of the correct directional bias under the other of the human's eyes.

\* \* \* \* \*

UNITED STATES PATENT AND TRADEMARK OFFICE  
**CERTIFICATE OF CORRECTION**

PATENT NO. : 5,939,142

Page 1 of 2

DATED : August 17, 1999

INVENTOR(S) : Stephen W. Comiskey, et. al.

It is certified that error appears in the above-identified patent and that said Letters Patent is hereby corrected as shown below:

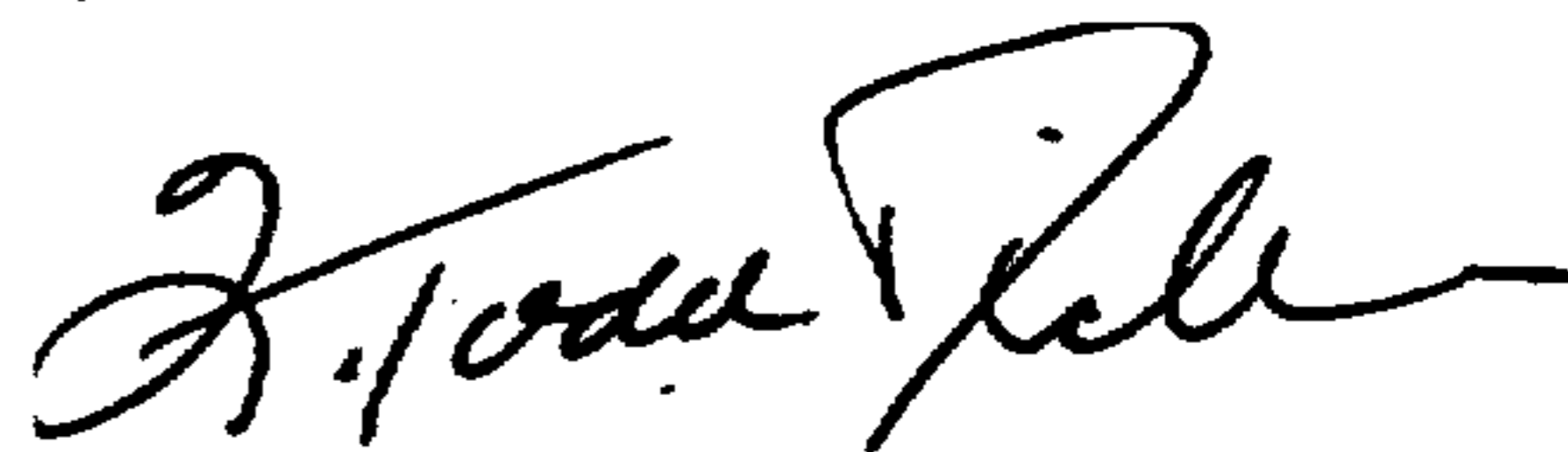
Title page, item [73], Assignee: change "Comisky" to --Comiskey--

Drawings:

Substitute the attached Figure 8 for Figure 8 appearing at Sheet 3 of the drawings.

Signed and Sealed this  
Twelfth Day of September, 2000

Attest:



Q. TODD DICKINSON

Attesting Officer

Director of Patents and Trademarks

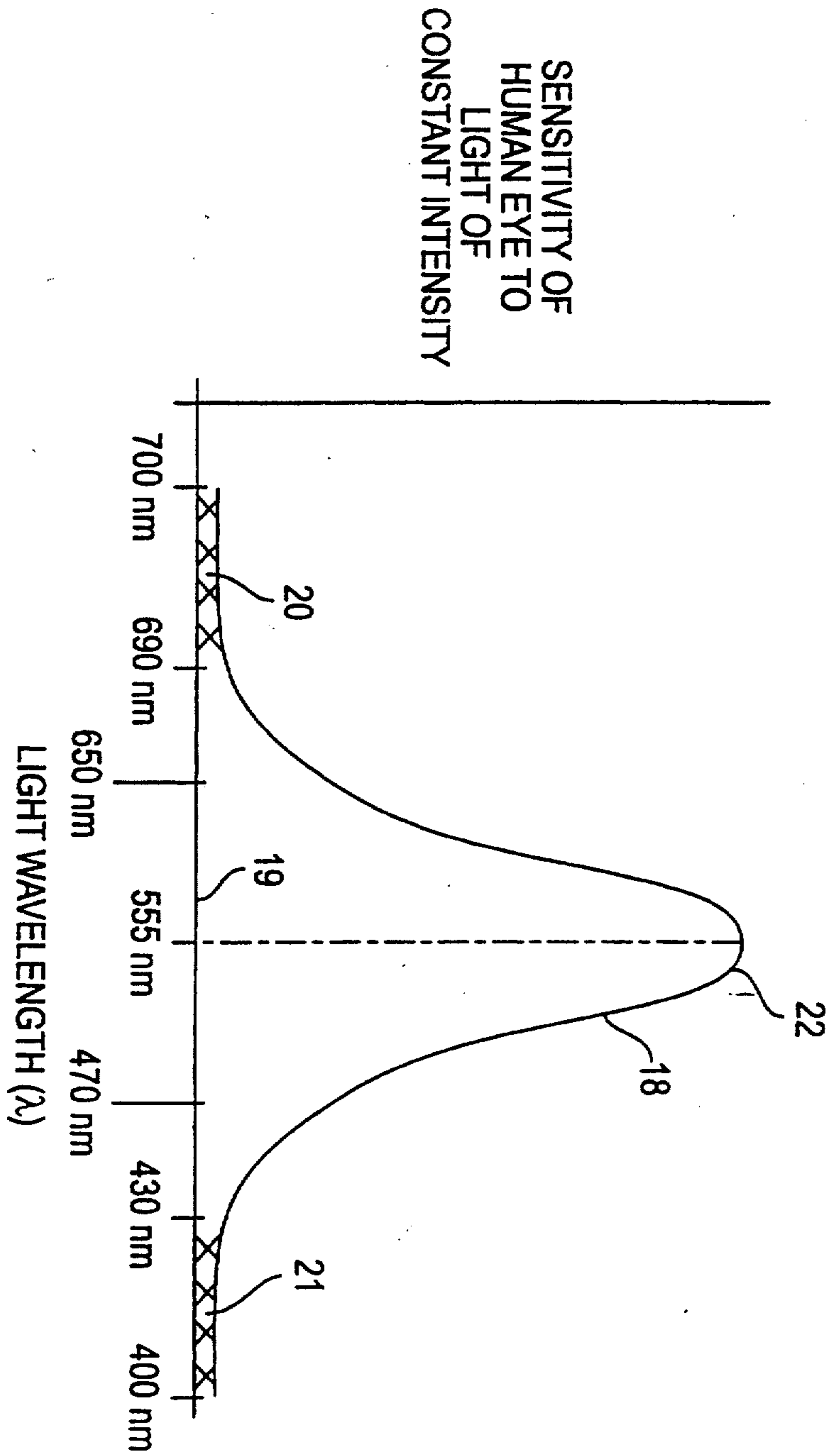


FIG. 8