



US005934221A

**United States Patent** [19]  
**Kirschner**

[11] **Patent Number:** **5,934,221**  
[45] **Date of Patent:** **Aug. 10, 1999**

[54] **DEVICE AND METHOD FOR WATERING A PET**

[76] Inventor: **Jonathan Kirschner**, 5224 Old Mountain La., Powder Springs, Ga. 30127

[21] Appl. No.: **08/933,180**

[22] Filed: **Sep. 18, 1997**

[51] **Int. Cl.<sup>6</sup>** ..... **A01K 7/00**

[52] **U.S. Cl.** ..... **119/72**

[58] **Field of Search** ..... 119/69.5, 72, 666, 119/667, 718; 239/16

[56] **References Cited**

**U.S. PATENT DOCUMENTS**

|           |         |               |         |
|-----------|---------|---------------|---------|
| 4,987,861 | 1/1991  | Lemire et al. | 119/667 |
| 5,063,880 | 11/1991 | Bouthillier   | 119/667 |
| 5,630,379 | 5/1997  | Gerck et al.  | 119/667 |

*Primary Examiner*—Robert P. Swiatek  
*Attorney, Agent, or Firm*—James L. Sherman

[57] **ABSTRACT**

A pet watering device is for automatically providing water to a pet, such as a dog, from a source of water under pressure. The pet watering device includes a water supply conduit having a first end which is operably connected to a faucet and a second end which is disposed remote from the faucet to allow a discharge of the water therefrom. A valve is in the water supply conduit for being opened to allow the water to flow through the water supply conduit and closed to prevent the flow of the water therethrough. The water supply conduit includes a mounting element for mounting the second end at a selected position for allowing the pet to drink the water therefrom. A sensor is for sensing the movement of the pet near the second end of the water supply conduit. The sensor is operably connected to the valve to cause the valve to be opened when the pet is sensed moving near the second end and to be closed after the pet is no longer sensed near the second end. The water supply conduit and the second end thereof are configured to facilitate the flow of water therethrough at a flow rate which will allow the pet to drink the water without being frightened thereby.

**34 Claims, 3 Drawing Sheets**

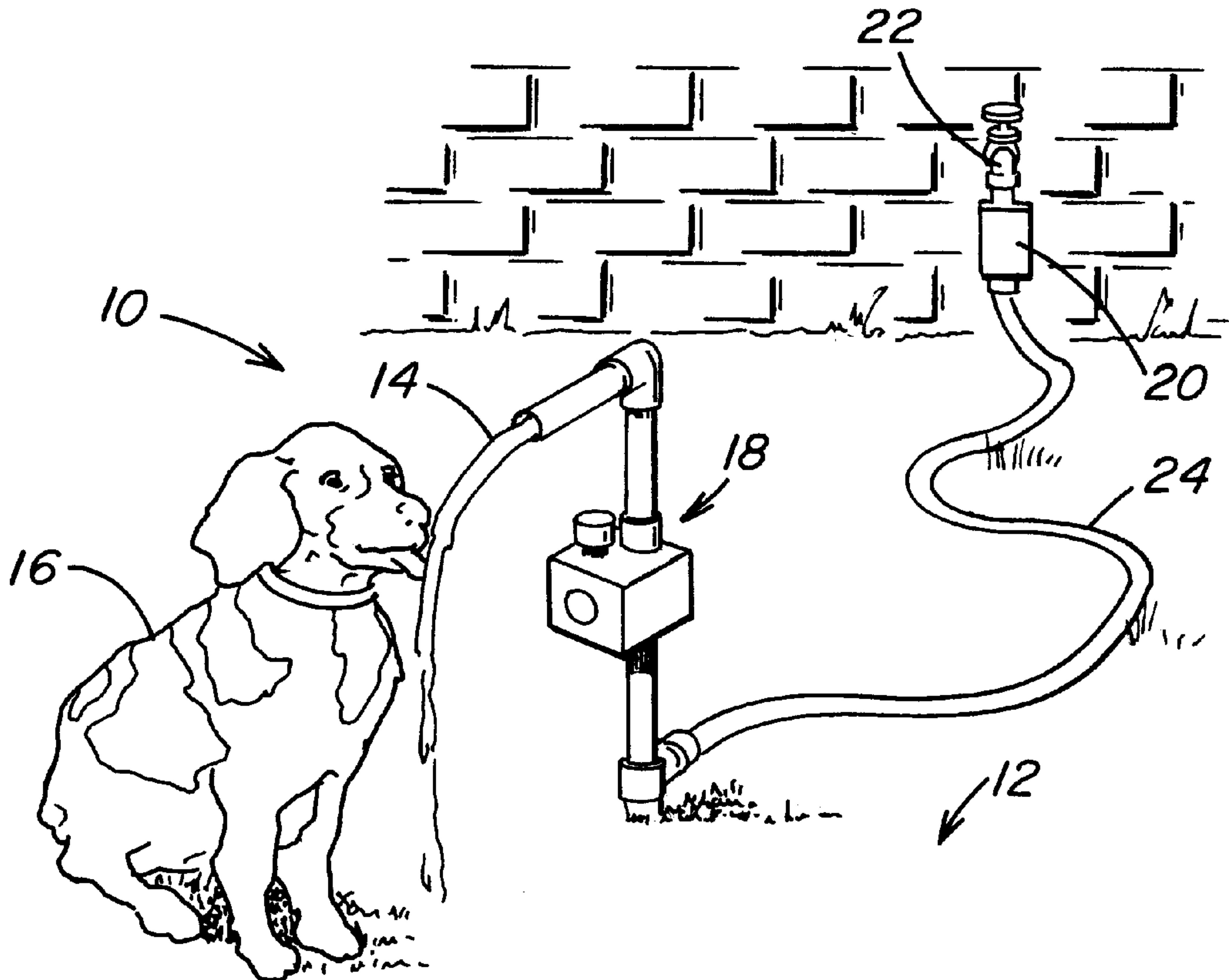

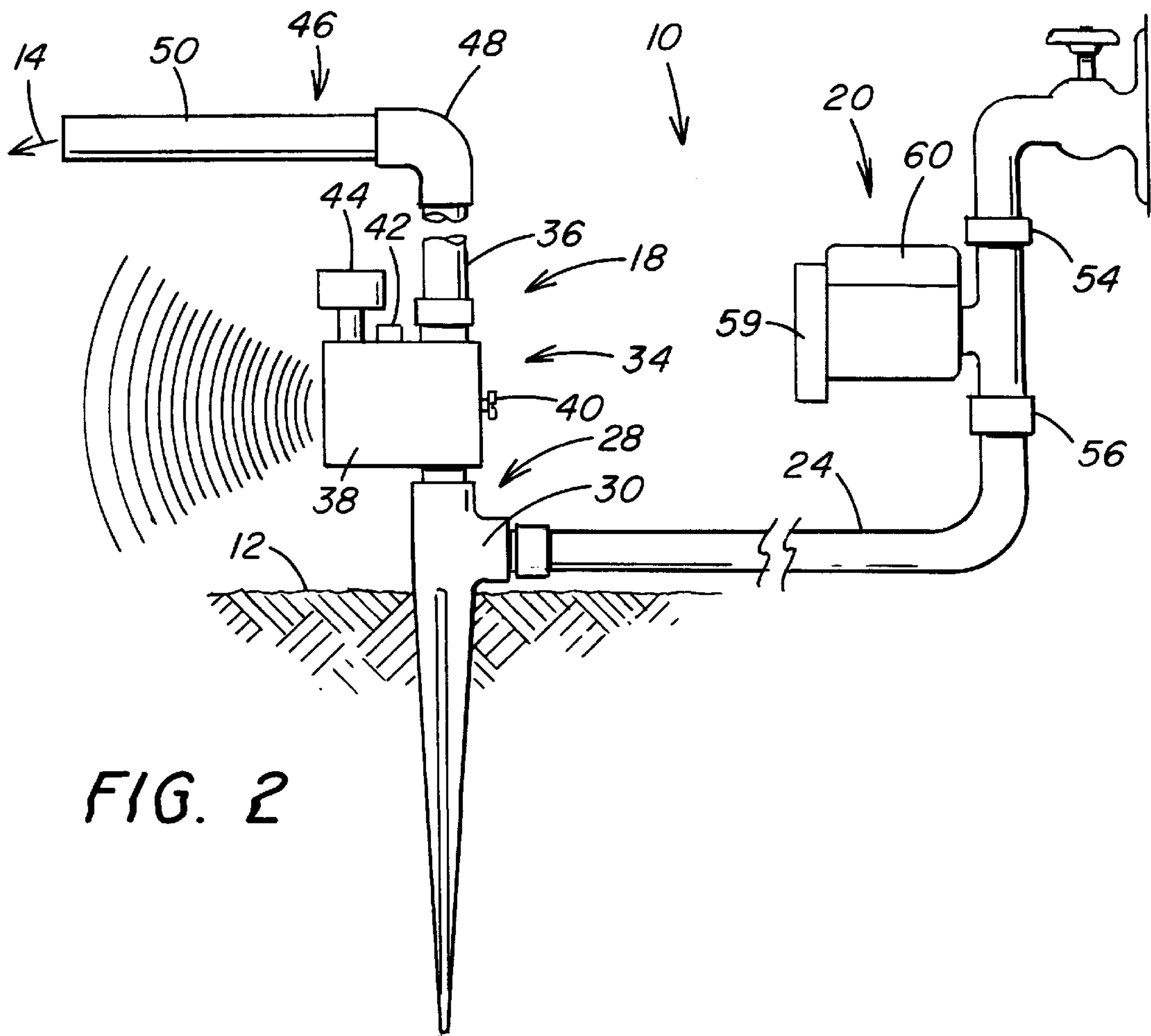
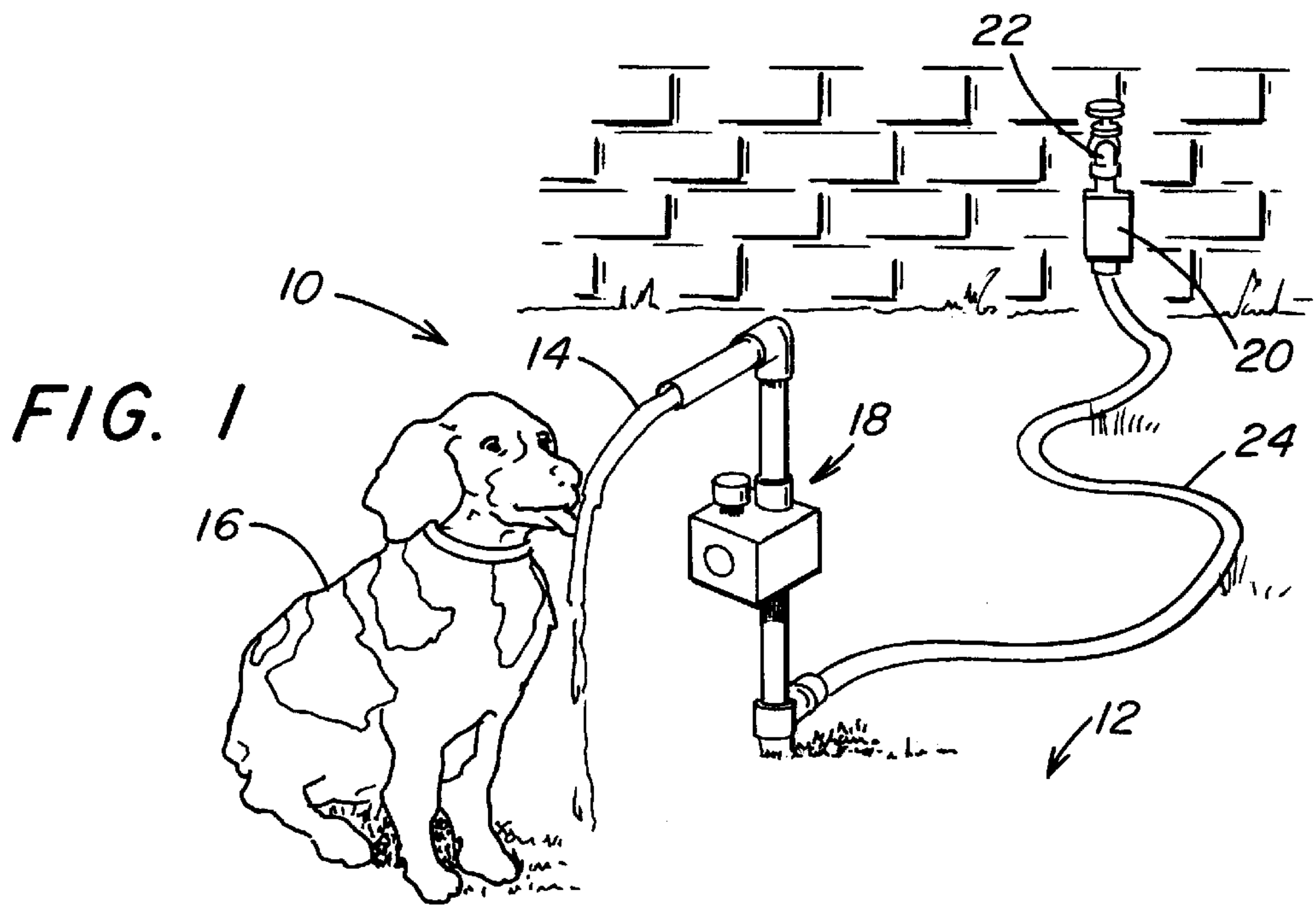

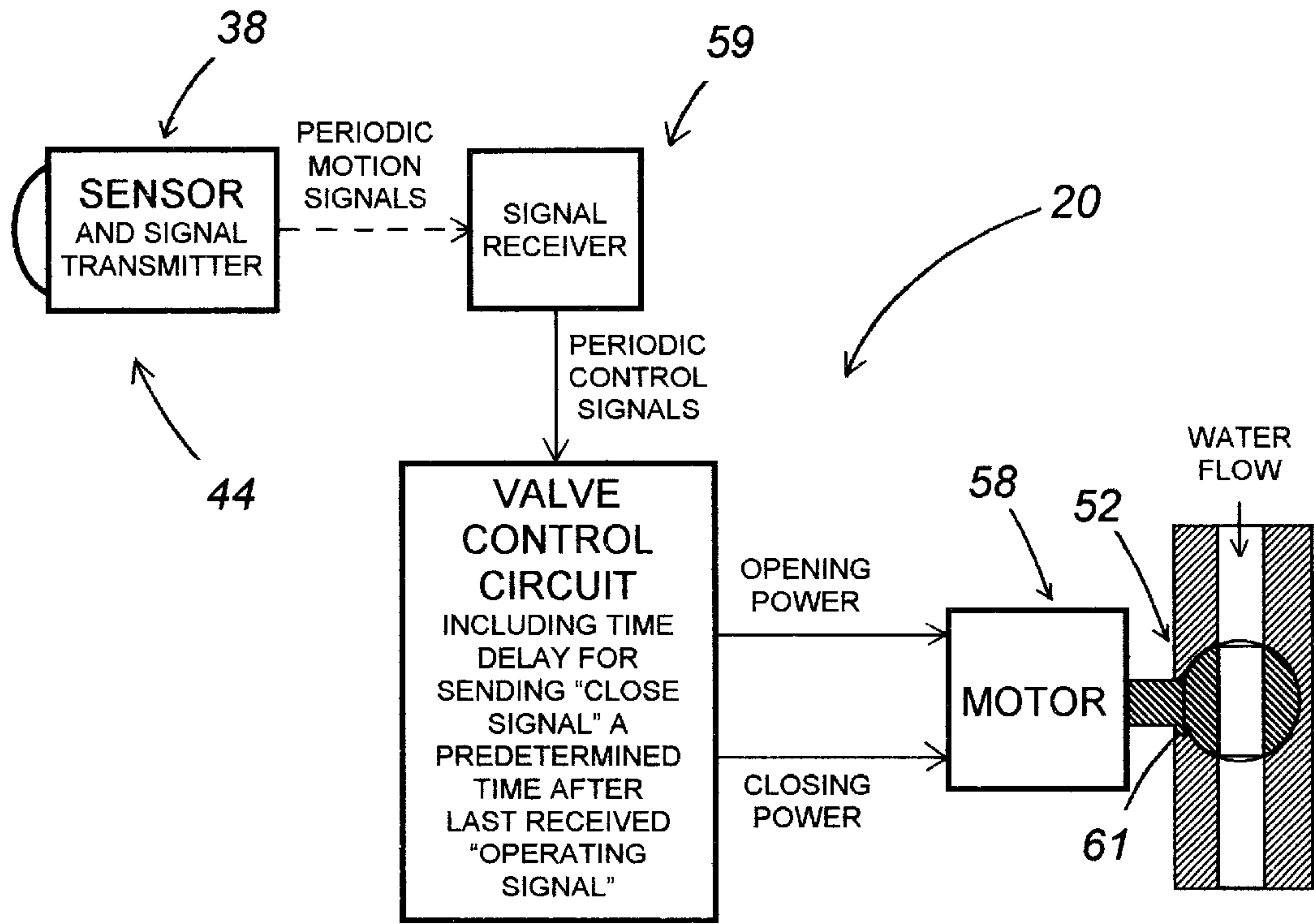

FIG. 3

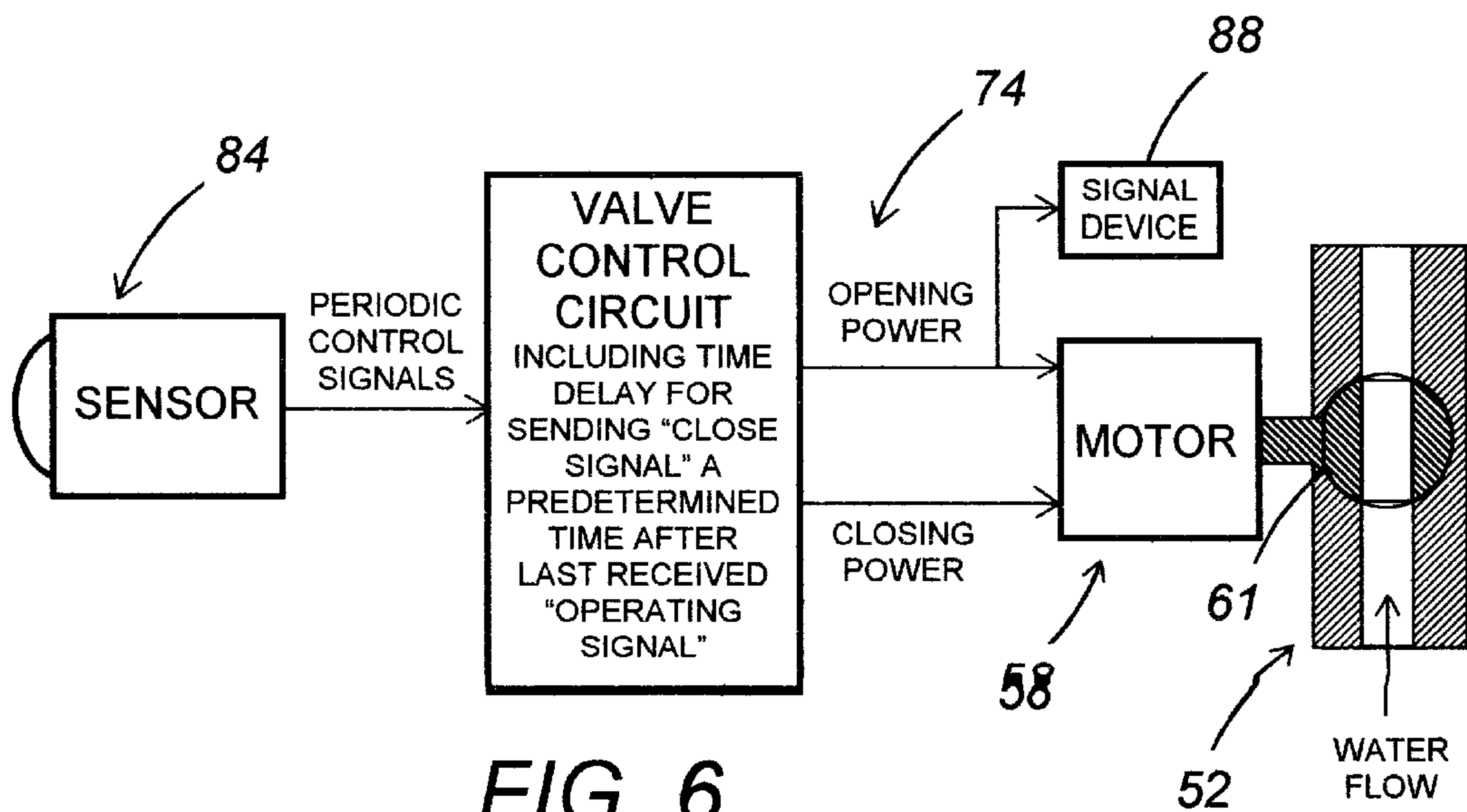

FIG. 6

FIG. 4

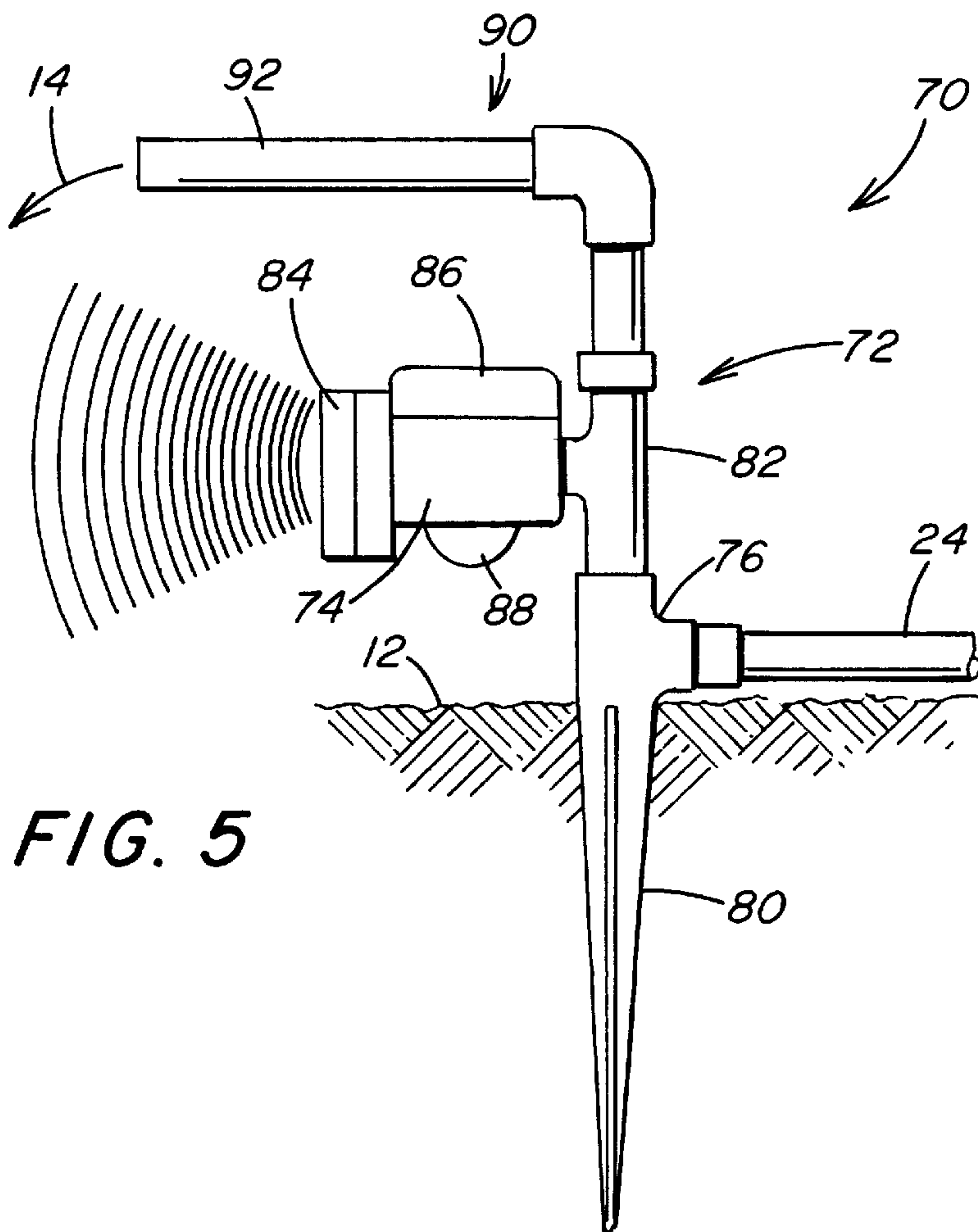
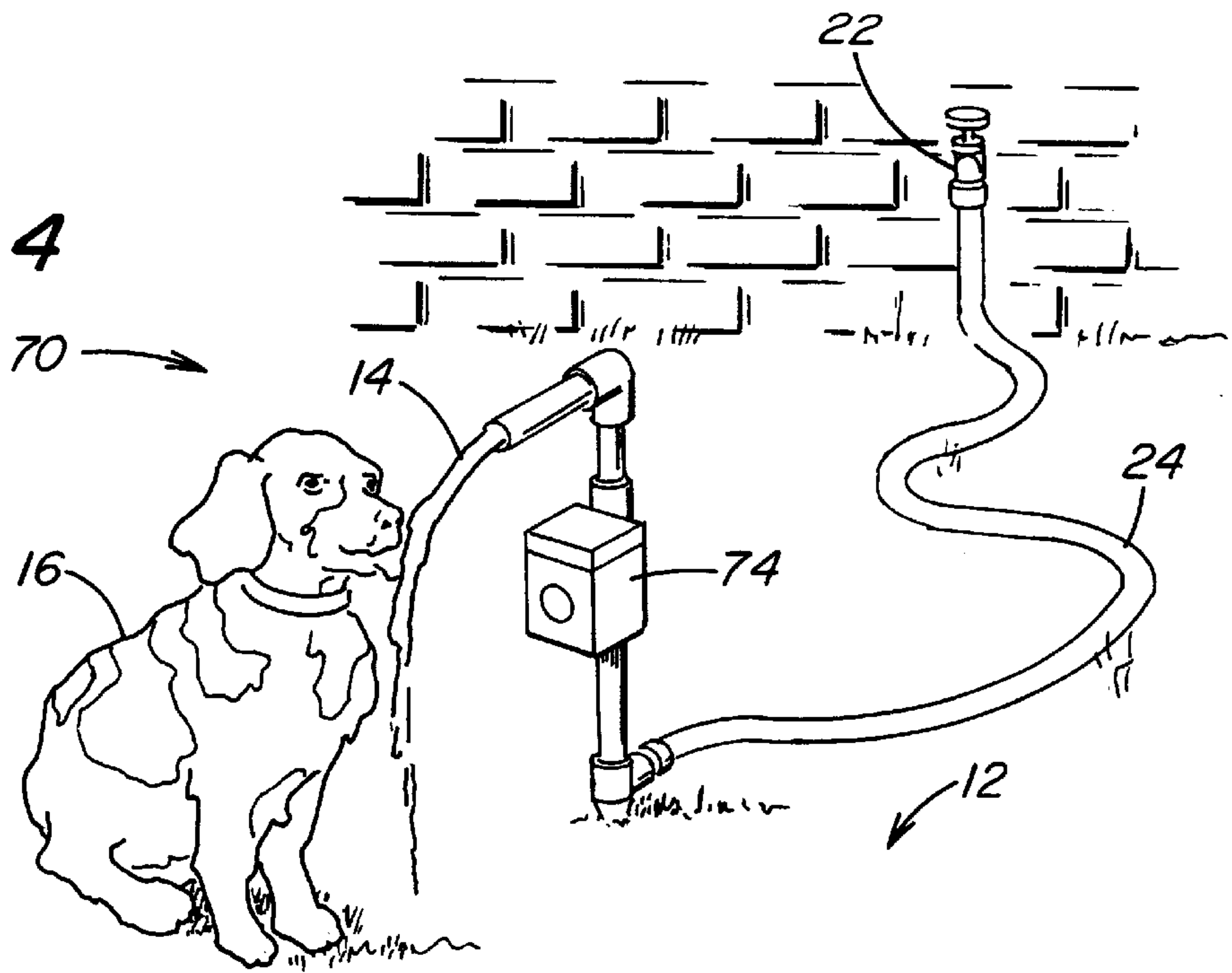

FIG. 5



## DEVICE AND METHOD FOR WATERING A PET

### BACKGROUND OF THE INVENTION

#### 1. Field of the Invention

This invention relates to a device for watering a pet, such as a dog, and, more specifically, to such a device which utilizes a source of water under pressure to direct water in a general outward direction at a convenient height for allowing access thereto by the pet when the pet is sensed in the general outward direction from the device.

#### 2. Brief Description of the Prior Art

While there is a need for providing water to pets, such as dogs, it is not uncommon for owners to simply provide a water dish or the like from which the pet is able to drink water as desired. The owner typically tries to maintain a sufficient quantity of water in the bowl for the pet over an extended period of time. However, the water in such bowls can become contaminated and not truly fit for drinking by the pet. In any case, it is also uncommon for the owner to sometimes fail to provide the water needed and thus cause the pet to be deprived of the desired amount of water. Additionally, if the owner has a number of pets having access to the bowl or bowls, such problems would be compounded. The failure to provide a sufficient quantity of water over an extended amount of time would be more significant if the pet or pets are being kept outside of the house where the temperature and conditions would be more critical if water is not available.

While some pet stores offer feeding dishes that include complicated means for metering out controlled amounts of food for pets over an extended period of time, the automatic supply of water has been a different matter and continues to be of concern. For pets which primarily remain within a house, the owner is at least periodically able to observe the water dish and much more likely to determine if more water is needed in the dish. However, with some pets, such as larger dogs, it is not uncommon for them to be kept outside of the house and thus outside of the frequent observation of the owner. When a water dish is used for pets that are kept outside of the house, the owner may not be in a position to frequently or accurately monitor the amount of water in the dish.

U.S. Pat. No. 4,986,221 disclosed a livestock waterer which is relatively complicated and expensive to provide. The device includes a bowl that must be mounted in a fixed location to provide a bottom drain system. The drain area includes a water supply line and has a drain valve which is capable of being automatically closed to collect the water and opened to release the water from the bowl. While the draining of the water would tend to prevent the contamination of the water, as discussed above, it is apparent that the device would by necessity be relatively complicated. The device includes one embodiment that employs an infrared sensor and an infrared detector to sense an object therebetween at the bowl and another embodiment employs a passive infrared detector to sense the presence of an animated body at the bowl. The device is intended to automatically supply water to the bowl when in use and to cause the water to drain from the bowl when not in use. While such a device to provide water to livestock at a outside location could be used for pets, the expense and difficulty of providing such a device tends to make its use for pets highly unlikely.

Accordingly, there remains a need for conveniently and reliably providing water to pets, preferably at an outside

location, where the need for water by the pets might be greater and more difficult to provide and monitor by owners.

On the other hand, as seen in U.S. Pat. No. 5,009,192, an animal deterrent apparatus is intended to be installed in a field, yard or garden to selectively activate a pulse type sprinkler connected to a garden hose or the like to produce noise and direct a jet spray of water toward a selected area. The objective is to detect the presence of an animal by an infrared sensor physically separated from the sprinkler but directed toward the area to frighten the animal away. The apparatus can include a plurality of such sensors and sprinklers and is expected to cover an area extending approximately 50 feet. When the presence of an animal is detected in the area by one of the sensors, the sprinklers are turned on by providing power to open a solenoid valve which remains activated until the animal leaves the area and, perhaps, for a few additional seconds by the use of a time delay feature.

There are presently available numerous devices for automatically supplying water to people for washing hands at a sinks, such as those disclosed in U.S. Pat. Nos. 4,839,039 (and Reexamination Certificate No. B1 4,839,039 related thereto); 4,872,485; 4,941,219; 5,074,520; and 5,074,520. In fact, U.S. Pat. No. 4,872,485 even includes an embodiment which is configured to turn on the water of a water fountain when the presence of a person is sensed at the fountain. Nevertheless, while these devices appear to work for the particular purpose as intended, it is clear that they are relatively complicated and expensive to provide and not configured to simple provide water to pets in a convenient or reliable manner and would therefore not be appropriate for such use.

### SUMMARY OF THE INVENTION

It is an object of the present invention to provide a pet watering device for automatically providing water to a pet, such as a dog, from a source of water under pressure.

It is another object to provide such a pet watering device which is capable of sensing the presence of the pet to automatically supply the water when the pet is moving near the device.

It is still another object to provide such a pet watering device which can be conveniently mounted on the ground and is configured to direct the water in a general outward direction at a convenient height to allow easy access thereto by the pet.

It is a further object to provide such a pet watering device with a configuration which will facilitate the flow of water therethrough at a flow rate to allow the pet to drink the water without being frightened thereby.

It is yet another object to provide such a pet watering device that can be easily installed at selected locations that are remote from the source of the water.

These and other objects of the invention are provided in a preferred embodiment thereof including a pet watering device for automatically providing water to a pet, such as a dog, from a source of water under pressure. The pet watering device includes a water supply conduit having a first end for being operably connected to the source of water and a second end for allowing a discharge of the water therefrom. A valve is in the water supply conduit for being opened to allow the water to flow through the water supply conduit and closed to prevent the flow of the water therethrough. The water supply conduit includes a mounting element for mounting the second end at a selected position for allowing the pet to drink the water therefrom. A sensor is for sensing the movement of the pet near the second end of the water



supply conduit. The sensor is operably connected to the valve to cause the valve to be opened when the pet is sensed moving near the second end and to be closed after the pet is no longer sensed near the second end. The water supply conduit and the second end thereof are configured to facilitate the flow of water therethrough at a flow rate which will allow the pet to drink the water without being frightened thereby.

In the preferred pet watering device, the source of water includes a faucet and the pet watering device is for being used with a hose. The water supply conduit includes a major portion independent of the valve. The major portion includes the second end and an input hose connection opposite of the second end. The valve includes the first end and an output hose connection opposite the first end. The first end is connected to the faucet. The output hose connection and the input hose connection are capable of being joined by the hose to allow the second end to be located remote from the faucet.

The preferred pet watering device is for being installed on a lawn and the major portion includes the mounting element for mounting on the ground and for directing the water from the second end in a general outward direction from the major portion at a convenient height above the ground for allowing the pet access thereto. The sensor is mounted on the major portion to sense the movement of the pet located in the general outward direction from the major portion. The sensor includes a signal transmitter and the valve includes a signal receiver. The sensor is operably connected to the valve by the transmission of a motion signal from the signal transmitter to the signal receiver when the pet is sensed moving near the second end of the major portion. The sensor can be adjusted for only sensing the movement of the pet within a range of about five feet from the second end. The sensor can include a sensor power source and the valve can include a valve power source independent of the sensor power source. The sensor power source could include a solar battery. The valve power source provides operating power to activate the valve and the operating power is preferably only utilized to cause the valve to open and to cause the valve to close.

The preferred pet watering device can further include a time delay feature for delaying the utilization of the operating power to close the valve after a predetermined amount of time during which the sensor does not sense any movement of the pet near the second end. The predetermined amount of time could be between ten and twenty seconds.

In another preferred pet watering device, the source of water includes a faucet and a hose which is capable of being connected from the faucet to the first end of the water supply conduit and the second end is located at the selected position remote from the faucet. The water supply conduit includes the mounting element for mounting in a fixed location relative to the ground and for directing the water from the second end in a general outward direction from the water supply conduit at a convenient height above the ground for allowing the pet access thereto. The valve is located between the first end and the second end. The sensor is mounted on the water supply conduit to sense the movement of the pet located in the general outward direction from the water supply conduit. The sensor can be adjusted for only sensing the movement of the pet within a range of about five feet from the second end.

In still another form of the preferred pet watering device, the valve includes a valve power source for providing operating power to activate the valve and the operating

power is only utilized to cause the valve to open and to cause the valve to close. The pet watering device can further include a time delay feature for delaying the utilization of the operating power to close the valve after a predetermined amount of time during which the sensor does not sense any movement of the pet near the second end. The preferred predetermined amount of time is between ten and twenty seconds.

In another embodiment of the invention, a pet watering device is for automatically providing water to a pet, such as a dog, in a lawn from a faucet under pressure and for use in conjunction with a hose. The pet watering device includes a water supply conduit including a valve and a major portion independent of the valve. The valve includes a first end and an output hose connection opposite the first end. The major portion includes a second end for allowing a discharge of the water therefrom and an input hose connection opposite of the second end. The first end is for being connected to the faucet. The output hose connection and the input hose connection are capable of being joined by the hose to allow the second end to be located remote from the faucet. The valve in the water supply conduit is for being opened to allow the water to flow from the faucet, though the hose and the major portion, and out of the second end and for being closed to prevent the flow of the water therethrough. The major portion includes a mounting element for mounting the major portion on the lawn and for directing the water from the second end in a general outward direction from the major portion to cause the second end to be at a selected position for allowing the pet to drink the water therefrom. A sensor is on the major portion for sensing the movement of the pet located near the second end in the general outward direction from the major portion. The sensor includes a signal transmitter and the valve includes a signal receiver. The sensor is operably connected to the valve by the transmission of a motion signal from the signal transmitter to the signal receiver when the pet is sensed moving near the second end of the major portion. The motion signal causes the valve to be opened when the pet is sensed moving near the second end and to be closed after the pet is no longer sensed near the second end. The water supply conduit and the second end thereof are configured to facilitate the flow of water therethrough at a flow rate which will allow the pet to drink the water without being frightened thereby.

It should be noted that the valve can include a valve power source for providing operating power to activate the valve and the operating power is only utilized to cause the valve to open and to cause the valve to close. The pet watering device could further include a time delay feature for delaying the utilization of the operating power to close the valve after a predetermined amount of time during which the sensor does not sense any movement of the pet near the second end. The predetermined amount of time is preferable between ten and twenty seconds. The sensor can be adjusted for only sensing the movement of the pet within a range of about five feet from the second end.

The invention also includes a method of automatically providing water to a pet, such as a dog, from a source of water under pressure. The preferred method includes the steps of:

- providing a water supply conduit having a first end for receipt of the water from the source of water and a second end for allowing discharge of the water therefrom;
- providing a valve in the water supply conduit between the first end and the second end for being selectively



opened to allow the water to flow through the water supply conduit and closed to prevent the flow of the water therethrough;  
 mounting the second end at a fixed location and in a position for allowing the pet to drink the water therefrom;  
 sensing the movement of the pet near the second end of the water supply conduit;  
 opening the valve after the sensing of the movement of the pet near the second end;  
 closing the valve after there is no longer any such sensing of the movement of the pet near the second end; and  
 causing the flow of the water through the second end to be at a controlled flow rate which will allow the pet to drink the water without being frightened thereby after the opening of the valve.

In the preferred method, the step of mounting includes locating the second end above the ground and the step of causing the flow of water includes directing the water from the second end in a general outward direction from the water supply conduit at a convenient height above the ground for allowing the pet access thereto. The step of sensing is provided by mounting a sensor on the water supply conduit adjacent the second end thereof for the sensing of the movement of the pet in the general outward direction from the water supply conduit.

Where the source of water includes a faucet, the step of providing the water supply conduit can include providing a major portion physically separated from the valve with the second end on the major portion and the first end on the valve. The method would further include steps of securing the first end to the faucet and installing a hose between the valve and the major portion of the water supply conduit. The step of sensing includes transmitting a motion signal from the sensor adjacent the second end and receiving the motion signal at the valve for the opening and the closing of the valve.

In one form of the preferred method, the source of water includes a faucet and a hose and the step of providing the water supply conduit includes connecting the hose between the faucet and the first end.

In the preferred method, the step of sensing only occurs when the pet is moving within a range of about five feet from the second end.

The method can further include the steps of providing operating power to activate the valve and only utilizing the operating power for the opening of the valve and for the closing of the valve.

The method can further include the step of delaying the utilizing of the operating power for the closing of the valve after a predetermined amount of time during which there is no such sensing of any movement of the pet near the second end. The preferred delaying is for the predetermined amount of time of between ten and twenty seconds.

#### BRIEF DESCRIPTION OF THE DRAWINGS

FIG. 1 is a view of the preferred pet watering device including various features of the invention as it would be installed in a lawn.

FIG. 2 is an elevational view of the preferred device of FIG. 1 with the valve thereof in the opened position.

FIG. 3 is a schematic diagram demonstrating the operation of the valve control circuitry for controlling the valve of the preferred device of FIG. 1.

FIG. 4 is a view of another preferred pet watering device including various features of the invention as it would be installed in a lawn.

FIG. 5 is an elevational view of the preferred device of FIG. 4 with the valve thereof in the opened position.

FIG. 6 is a schematic diagram demonstrating the operation of the valve control circuitry for controlling the valve of the preferred device of FIG. 4.

#### DETAILED DESCRIPTION OF THE PREFERRED EMBODIMENTS

As seen in FIGS. 1, 2 and 3, the preferred pet watering device 10 is installed on a lawn, yard or ground 12 for automatically providing water 14 for a pet, such as a dog 16, from a source of water under pressure. The preferred pet watering device 10 basically includes water conduit element that is primarily formed of two parts, a major outlet portion 18 and a valve portion 20. The valve portion 20 is configured to be installed on an outside faucet 22, the preferred source of water under pressure. A conventional hose 24 is used to connect the valve portion 20 to the major outlet portion 18 to allow the major outlet portion 18 to be installed at any convenient location on the lawn or ground 12. As will be seen, when the major outlet portion 18 is properly installed on the lawn 12 at a desired location, the pet 16 will be able to approach to within about five feet of the major outlet portion 18 to automatically activate the device 10 to cause water 14 to flow therefrom in a manner that allows the pet 16 to drink the water 14. The water 14 from the device 10 will preferably flow at a maximum rate of less than about three gallons per minute and with a velocity which will not produce any loud noises to frighten the pet 16 but will allow the pet 16 to drink directly therefrom as it flows generally outwardly to the ground 12.

The major outlet portion 18 includes a base 28 that has an inlet connection 30 for the hose 24 and a spike 32 for being securely mounted in the ground 12. The central region 34 includes a portion of the conduit that extends vertically above to the ground 12 and may include means for altering the height thereof above the ground 12. For example, with the preferred device 10, alternative pipe sections 36 of different lengths or a single pipe section 36 which could be cut to a desired length can be provided for installation by the owner to provide the desired height above the ground for the particular pet intended to use the device 10.

The central region 34 also includes a sensor means 38 which preferably senses the movement of the pet within a maximum range of about five feet. The preferred sensor means 38 includes physical adjusting means 40 for adjusting the location and direction of the sensor means 38 on the central region 34 of the major outlet portion 18. Additionally, the preferred sensor means 38 is an infrared detector of the reflector type which is well known in the sensing art and may also include electronic adjusting means for adjusting the sensitivity thereof in order to insure that the pet 16 is only sensed when moving relatively close to the major outlet portion 18 and not when it is simply walking thereby at some remote distance. Although conventional batteries could be used as the power source, the preferred sensor means 38 is powered by a solar battery 42 and is further adapted to transmit a motion signal through a signal transmitter 44 each time the movement of the pet 16 is detected. The use of the motion signal for causing the opening and the closing of the valve in the valve portion 20 will be discussed hereinbelow.

As will be seen, providing the preferred sensor means 38 with the solar battery 42 and with the signal transmitter 44 allows the major outlet portion 34 to be easily and conveniently separated from the valve portion 20 and the faucet



22. Although a "line-of-sight" must be maintained between the signal transmitter 44 on the major outlet portion 34 and the valve portion 20 of the preferred device 10, the general limit on the distance therebetween would be the length of the connecting hose 24.

The major outlet portion 18 most significantly includes an upper region 46 having an elbow 48 connected to the pipe 36 for supporting a second end 50 of the major outlet portion 18. The second end 50 extends horizontally in a direction generally outwardly of the central region 34. When the device 10 is activated, water 14 will flow from the second end 50 at a flow rate which will allow the pet to drink therefrom but without creating sufficient spraying or noise that would tend to scare the pet 16.

As best seen in FIG. 3, to actually control the flow of water through the device 10, the valve portion 20 preferably includes a rotatable ball valve 52 which is to be opened when the pet is moving near the second end 50 and to be closed after the pet is no longer near the second end 50. The valve portion 20 includes a first end 54 for being directly connected to the outlet of the faucet 22 and an outlet end 56 to which one end of the hose 24 is connected. The valve portion 20 includes a valve operator which, in the preferred device 10, is a motor 58 which will cause rotation of the ball valve 52 and associated control circuitry of the type which is well known in the valve control art. While numerous types of solenoid operated valves might be used, the preferred valve is the rotating ball valve 52 that can be rotated in one direction into alignment by the motor 58 to allow the water to flow therethrough. To close the valve 52, the motor 58 is rotated in the other direction to block the flow of the water. The rotating ball valve 52 is preferred because it allows the valve control circuit to be configured to only require operating power when the valve 52 is being specifically opened and when the valve 52 is being specifically closed.

In order to cause the valve 52 to open and close in response to the movement of the pet 16 near the second end 50 of the major portion 18, the valve portion 20 includes a signal receiver 59 for receiving an initial motion signal from the transmitter 44 as soon as the pet is sensed to be moving within the range of the sensor means 38. The signal receiver 59 is operably connected to the valve control circuit and provides a control signal thereto whenever any motion signal is received from the transmitter 44. The valve control circuit includes the operating power for both the signal receiver 58 and the motor 58 from a battery 60 which is expected to simply include one conventional nine volt battery.

The sensor means 38 will detect any motion from a pet and cause a motion signal to be transmitted each time any motion is detected. When the motion signal is first received by the signal receiver 59, the valve control circuit will provide opening power to the motor 58 for a required amount of time to rotate the ball valve 52 from the closed position (not shown) through ninety degrees to open the valve 52 for the flow of water therethrough as shown in FIG. 3. After the required time, the opening power for the motor 58 is discontinued so that the valve 52 will physically be at the opened position. A mechanical stop 61 is also provided in the valve 52 to insure that the opened position is accurately obtained. As will be seen, once the valve 52 is opened, it will remain opened without any power being provided thereto until the valve control circuit causes the valve 52 to be closed.

The signal receiver 59 will continue to receive motion signals from the transmitter 44 as long as there is any movement of the pet 16 being sensed and will provide a

corresponding control signals to the valve control circuit. However, when the valve control circuit receives additional control signals, it does not continue to power the motor 58 or needlessly reduce the power in the battery after it has been opened.

After the valve 52 has been opened, the valve control circuit utilizes a time delay means that is started each time there is a discontinuation of the control signals. The time delay means remains active as long as there are no new control signals but will begin each time that any newly received control signal is discontinued. If, after the time delay means has been activated, no new control signal is received for a predetermined amount of time, the valve control circuit will provide the closing power to the motor 58 for the required time to cause the valve 52 to rotate in the opposite direction to stop the flow of the water therethrough. The mechanical stop 61 again insures that the closed position is accurately obtained. Once closed, no more power is provided to the motor 58 and the valve 52 remains closed until a new movement of the pet is sensed by the sensor means 38 and the valve 52 is opened to repeat the entire process.

In operation, when a pet moves within the range of the sensor means 38, the valve 52 will open and water will flow from the second end 50 for the pet to drink therefrom. It has been found that when the pet is drinking the water it is not uncommon for the pet to remain relatively still so that the sensor means 38 no longer senses any movement. Without the time delay means, the valve 52 would be closed and the water would stop flowing. However, in the preferred device 10, the water will continue to flow for the predetermined amount of time to allow the pet to continue to drink. Admittedly, after the predetermined amount of time the pet may still be at the second end 50 and in a position to drink, but the valve 52 will be closed and the pet will not then be able to continue drinking the water. However, any movement by the pet, such as, for example, simply moving away from the second end 50, will cause the valve 52 to be opened to cause the water to begin flowing again. After the pet 16 leaves the range of the sensor 38, the valve 52 will be closed after the predetermined amount of time and the water will stop flowing. The predetermined amount of time for the time delay means is preferably between ten to twenty seconds and about fifteen seconds has resulted in satisfactory operation of the device 10.

It has been found that various pets soon learn that the water might on occasion stop flowing but that it will begin to flow again once there is some new movement by the pet. Although the discussion above is generally directed to a use of the device 10 for one pet, it would be possible for several pets to attempt to use the device 10 at about the same time. The device 10 would operate to open the valve 52 whenever the sensor means 38 senses any movement of one or more pets within the range of the sensor means 38 and to attempt to close the valve 52 after no movement is being sensed. The presence of additional pets might increase the "activity" of the sensor means 38 but, because of the time delay means, there would not be any undue opening or closing of the valve 52 which would needlessly increase the power required for the operation of the device 10. In any case, the preferred valve portion 20 is configured to save power and thus the life of the battery by only requiring operating power for the activation of the motor 58 to open the valve 52 and for the activation of the motor 58 to close the valve 52. It will be apparent to those skilled in the valve control art that there are many valve configurations that employ solenoids that require operating power throughout



the time the valve is opened and that such valve configurations would require a greater amount of power to operate the valve and would thus significantly reduce the life of the battery.

The preferred pet watering device **10** is particularly configured to provide a number of desired features intended to improve its overall operation. For example, the device **10** includes the physically separated valve portion **20** and major outlet portion **18** in order to prevent the hose **24** from being continuously operated under water pressure. It is not uncommon for hoses and/or the end fittings thereof to develop leaks when maintained under pressure over an extended period of time. With normal use, hoses tend to last a number of years. However, it has been found that hoses maintained under pressure for days and days cause stress that will cause the hose to fail prematurely. If such a failure occurs when the owner was not present, the uncontrolled loss of water could create serious problems. The preferred configuration would tend to eliminate any such possibility.

Still further, the ball of the valve **52** and other passages through the device **10** are generally sized to restrict the flow of the water therethrough to about three gallons per minute for a typical water pressure at the faucet **22**. While the faucet **22** could be partially closed to further restrict the maximum flow of the water if a reduced rate is desired for a particular pet, the maximum flow rate of about three gallons per minute provided by the design of the valve **58** and passages would allow the faucet **22** to be completely opened in a manner well known in the valve art to prevent leaking around the stem when the faucet **22** is under full pressure.

As seen in FIGS. **4**, **5** and **6**, another preferred wet watering device **70**, which is simpler and less expensive to provide than the device **10**, does not include all of the features thereof and might be used in situations where the device **70** is only used under faucet pressure periodically and for limited amounts of time. However, the device **70** does include other features that might also be employed in the device **10**. The device **70** has conduit means **72** which includes valve means **74** therein rather than being physically separated for direct installation on the faucet **22**. Instead, the source of the water under pressure for the device **70** is the faucet **22** and an attached hose **24** which is connect to the first end **76** at the base **78** of the conduit means **72**. A spike **80** is again employed to mount the device **70** on the ground **12**. A central region **82** of the device **70** includes the valve means **74** which is again configured to be opened and closed as required for the control of the water therethrough. The upper region **90** of the device **70** again has a horizontally extending second end **92** from which the water **14** for the pet **16** will flow at the maximum rate of about three gallons per minute and at a velocity which would not tend to frighten the pet **16** by creating movement which is too rapid or noise that is too loud.

In the device **70**, the sensor **84**, generally configured like the sensor **38**, is mounted directly on the body of the valve means **74**. Accordingly, there is no need for a transmitter **44** or a separate source of power **42** for the sensor **84**. Instead, the power for the sensor **84** and the valve control circuit of the valve means **74** would be a single nine volt battery **86**. As best seen in FIG. **6**, the valve means **74** again includes a valve control circuit, a motor **58**, a ball valve **52** and a mechanical stop **61** like those of the valve portion **20**. However, the device **70** has includes therein a signal device **88**, such as small buzzer or bell, which is also activated by the valve control circuit as the opening power is being provided to the ball valve **52**. The small buzzer or bell is intended to simply attract the attention of the pet **16** as the

water **14** is being supplied at the second end **92**. The periodic activation of the buzzer or bell might also provide an audible indication to the owner when and how often the device is being used by the pet or pets **16**.

The other preferred pet watering device **70** will function in the same manner as the device **10**. When a pet is first sensed moving near the second end **92**, the valve control circuit will again cause the valve **52** to open to allow the water to be discharged from the second end **92** in a general outward direction from the device **70** to allow the pet to drink the water. Because of the time delay means, the valve **52** will again only be closed at the end of the predetermined amount of time after the last movement of the pet is sensed by the sensor **84**. Consequently, the overall configuration of the device **70** will only require a minimum amount of power to open and close the valve **52** to significantly extend the life of the battery **86**.

It is clear from the discussions of the preferred embodiments that any number of alterations could be provided thereto without departing from the scope of the invention as claimed. For example, while the batteries **60** and **86** are preferred, it would be possible to include another source of power, such as house power, that would work satisfactorily but would tend to complicate the installation of the devices. While the reflector type of infrared detector is preferred, it should be clear to those skilled in the sensing art that other sensors could be employed. For example, a beam type of infrared detector or an ultrasonic detector could as be used to sense the movement or presence of the pet near the second, outlet end of the device. In fact, if a particular installation of the device would appear to include a significant number of "false" signals, such as with the detection of birds, animals or people that are not intended to operate the device, a transmitter-receiver sensor configuration could be used. Such a sensor configuration would include the receiver thereof mounted on and associated with the device for only being activated (to open the valve and supply the water) by a transmitter which could be attached, for example, to the collar of the pet for which the water is intended.

While it is clear that the preferred embodiments of the invention are particularly configured for installation in a lawn or yard for the discharge of the water on the ground, there is nothing to prevent the invention as claimed from being used in other manners while still falling within the scope of the invention as claimed. For example, there would be nothing to prevent the devices as taught herein from being altered to included a different mounting means which would allow them to be installed on a patio or in a garage area having a drain to allow the hose to be conveniently located in a shaded area so that the temperature of the water therein would not be significantly raised between uses. In fact, a similar such device could even be installed in a large walk-in shower within a house to enable automatic watering of a pet being kept within a house rather than only when the pet is located in lawn or yard of the house. It should be clear that any number of alterations could be made to the preferred embodiments without departing from the scope of the invention as claimed.

What is claimed is:

1. A pet watering device for automatically providing water to a pet, such as a dog, from a source of water under pressure, said pet watering device comprising:

water supply conduit means having a first end for being operably connected to the source of water and a second end for allowing a discharge of the water therefrom;  
valve means in said water supply conduit means for being opened to allow the water to flow through said water



## 11

supply conduit means and closed to prevent the flow of the water therethrough;

said water supply conduit means including mounting means for mounting said second end at a selected position for allowing the pet to drink the water therefrom;

sensing means for sensing the movement of the pet near said second end of said water supply conduit means; said sensing means being operably connected to said valve means to cause said valve means to be opened when the pet is sensed moving near said second end and to be closed after the pet is no longer sensed near said second end; and

said water supply conduit means and said second end thereof being configured to facilitate the flow of water therethrough at a flow rate which will allow the water to flow generally outwardly from said second end without creating a spray to allow the pet to drink the water without being frightened thereby.

2. The pet watering device as set forth in claim 1, wherein the source of water includes a faucet and said pet watering device is for being used with a hose, said water supply conduit means includes a major portion independent of said valve means, said major portion includes said second end and an input hose connection opposite of said second end, said valve means includes said first end and an output hose connection opposite said first end, said first end is connected to the faucet, and said output hose connection and said input hose connection are capable of being joined by the hose to allow said second end to be located remote from the faucet.

3. The pet watering device as set forth in claim 2, wherein said pet watering device is for being installed on a lawn, said major portion of said water supply conduit means includes said mounting means for mounting on the ground and for directing the water from said second end in a general outward direction from said major portion at a convenient height above the ground for allowing the pet access thereto.

4. The pet watering device as set forth in claim 3, wherein said sensing means is mounted on said major portion of said water supply conduit means to sense the movement of the pet located in said general outward direction from said major portion.

5. The pet watering device as set forth in claim 4, wherein said sensing means includes a signal transmitter, said valve means includes a signal receiver, and said sensing means is operably connected to said valve means by the transmission of a motion signal from said signal transmitter to said signal receiver when the pet is sensed moving near said second end of said major portion.

6. The pet watering device as set forth in claim 5, wherein said sensing means includes adjustment means for only sensing the movement of the pet within a range of about five feet from said second end.

7. The pet watering device as set forth in claim 6, wherein said sensing means includes a sensor power source and said valve means includes a valve power source independent of said sensor power source.

8. The pet watering device as set forth in claim 7, wherein said sensor power source includes a solar battery.

9. The pet watering device as set forth in claim 7, wherein said valve power source provides operating power to activate said valve means and said operating power is only utilized to cause said valve means to open and to cause said valve means to close.

10. The pet watering device as set forth in claim 9, further including time delay means for delaying the utilization of said operating power to close said valve means after a

## 12

predetermined amount of time during which the sensing means does not sense any movement of the pet near said second end.

11. The pet watering device as set forth in claim 10, wherein said predetermined amount of time is between ten and twenty seconds.

12. The pet watering device as set forth in claim 1, wherein the source of water includes a faucet and a hose which is capable of being connected from the faucet to said first end of said water supply conduit means and said second end is located at said selected position remote from the faucet.

13. The pet watering device as set forth in claim 12, wherein said water supply conduit means includes said mounting means for mounting in a fixed location relative to the ground and for directing the water from said second end in a general outward direction from said water supply conduit means at a convenient height above the ground for allowing the pet access thereto.

14. The pet watering device as set forth in claim 13, wherein said valve means is located between said first end and said second end and said sensing means is mounted on said water supply conduit means to sense the movement of the pet located in said general outward direction from said water supply conduit means.

15. The pet watering device as set forth in claim 14, wherein said sensing means includes adjustment means for only sensing the movement of the pet within a range of about five feet from said second end.

16. The pet watering device as set forth in claim 1, wherein said valve means includes a valve power source for providing operating power to activate said valve means and said operating power is only utilized to cause said valve means to open and to cause said valve means to close.

17. The pet watering device as set forth in claim 16, further including time delay means for delaying the utilization of said operating power to close said valve means after a predetermined amount of time during which the sensing means does not sense any movement of the pet near said second end.

18. The pet watering device as set forth in claim 17, wherein said predetermined amount of time is between ten and twenty seconds.

19. A pet watering device for automatically providing water to a pet, such as a dog, in a lawn from a faucet under pressure and for being used in conjunction with a hose, said pet watering device comprising:

water supply conduit means including valve means and a major portion independent of said valve means;

said valve means includes a first end and an output hose connection opposite said first end;

said major portion including a second end for allowing a discharge of the water therefrom and an input hose connection opposite of said second end;

said first end for being connected to the faucet;

said output hose connection and said input hose connection being capable of being joined by the hose to allow said second end to be located remote from the faucet;

said valve means in said water supply conduit means for being opened to allow the water to flow from the faucet, though the hose and said major portion, and out of said second end and for being closed to prevent the flow of the water therethrough;

said major portion including mounting means for mounting said major portion on the lawn and for directing the water from said second end in a general outward



direction from said major portion to cause said second end to be at a selected position for allowing the pet to drink the water therefrom;

sensing means on said major portion for sensing the movement of the pet located near said second end in said general outward direction from said major portion; said sensing means including a signal transmitter;

said valve means including a signal receiver;

said sensing means being operably connected to said valve means by the transmission of a motion signal from said signal transmitter to said signal receiver when the pet is sensed moving near said second end of said major portion;

said motion signal causing said valve means to be opened when the pet is sensed moving near said second end and to be closed after the pet is no longer sensed near said second end; and

said water supply conduit means and said second end thereof being configured to facilitate the flow of water therethrough at a flow rate which will allow the pet to drink the water without being frightened thereby.

**20.** The pet watering device as set forth in claim **19**, wherein said valve means includes a valve power source for providing operating power to activate said valve means and said operating power is only utilized to cause said valve means to open and to cause said valve means to close.

**21.** The pet watering device as set forth in claim **20**, further including time delay means for delaying the utilization of said operating power to close said valve means after a predetermined amount of time during which the sensing means does not sense any movement of the pet near said second end.

**22.** The pet watering device as set forth in claim **21**, wherein said predetermined amount of time is between ten and twenty seconds.

**23.** The pet watering device as set forth in claim **19**, wherein said sensing means includes adjustment means for only sensing the movement of the pet within a range of about five feet from said second end.

**24.** A method of automatically providing water to a pet, such as a dog, from a source of water under pressure, said method comprising the steps of:

providing water supply conduit means having a first end for receipt of the water from the source of water and a second end for allowing discharge of the water therefrom;

providing valve means in said water supply conduit means between said first end and said second end for being selectively opened to allow the water to flow though said water supply conduit means and closed to prevent the flow of the water therethrough;

mounting said second end at a fixed location and in a position for allowing the pet to drink the water therefrom;

sensing the movement of the pet near said second end of said water supply conduit means;

opening said valve means after said sensing of the movement of the pet near said second end;

closing said valve means after there is no longer any said sensing of the movement of the pet near said second end; and

causing the flow of the water through said second end to be at a controlled flow rate which will allow the pet to drink the water without being frightened thereby after said opening of said valve means.

**25.** The method as set forth in claim **24**, wherein said step of mounting includes locating said second end above the ground and said step of causing the flow of water includes directing the water from said second end in a general outward direction from said water supply conduit means at a convenient height above the ground for allowing the pet access thereto.

**26.** The method as set forth in claim **25**, wherein said step of sensing is provided by mounting a sensor on said water supply conduit means adjacent said second end thereof for said sensing of the movement of the pet in said general outward direction from said water supply conduit means.

**27.** The method as set forth in claim **26**, wherein the source of water includes a faucet, said step of providing the water supply conduit means includes providing a major portion physically separated from said valve means with said second end on said major portion and said first end on said valve means and further including the steps of securing said first end to the faucet and installing a hose between said valve means and said major portion of said water supply conduit means.

**28.** The method as set forth in claim **27**, wherein said step of sensing includes transmitting a motion signal from said sensor adjacent said second end and receiving said motion signal at said valve means for said opening and said closing of said valve means.

**29.** The method as set forth in claim **24**, wherein the source of water includes a faucet and a hose and said step of providing said water supply conduit means includes connecting the hose between the faucet and said first end.

**30.** The method as set forth in claim **24**, wherein said step of sensing only occurs when the pet is moving within a range of about five feet from said second end.

**31.** The method as set forth in claim **24**, further including the steps of providing operating power to activate said valve means and only utilizing said operating power for said opening of said valve means and for said closing of said valve means.

**32.** The method as set forth in claim **31**, further including the step of delaying said utilizing of said operating power for said closing of said valve means after a predetermined amount of time during which there is no said sensing of any movement of the pet near said second end.

**33.** The method as set forth in claim **32**, wherein said delaying is for said predetermined amount of time of between ten and twenty seconds.

**34.** A pet watering device for automatically providing water to a pet, such as a dog, from a source of water under pressure, said pet watering device comprising:

water supply conduit means having a first end for being operably connected to the source of water and a second end for allowing a discharge of the water therefrom;

valve means in said water supply conduit means for being opened to allow the water to flow though said water supply conduit means and closed to prevent the flow of the water therethrough;

said water supply conduit means including mounting means for mounting said second end at a selected position for allowing the pet to drink the water therefrom;

sensing means for sensing the movement of the pet near said second end of said water supply conduit means; said sensing means being operably connected to said valve means to cause said valve means to be opened when the pet is sensed moving near said second end and to be closed after the pet is no longer sensed near said second end;



**15**

said water supply conduit means and said second end thereof being configured to facilitate the flow of water therethrough at a flow rate which will allow the pet to drink the water without being frightened thereby;  
said valve means including a valve power battery having a limited battery life to provide operating power to activate said valve means; and

**16**

said operating power only being utilized to cause said valve means to open and to cause said valve means to close to extend the time that said pet watering device can be used to water the pet prior to the termination of said limited battery life.

\* \* \* \* \*