



US005907958A

United States Patent [19]

[11] Patent Number: **5,907,958**

Coates et al.

[45] Date of Patent: ***Jun. 1, 1999**

[54] **REFRIGERATOR WATER FILTER**

[75] Inventors: **Donald A. Coates**, Columbus; **Robert C. Russell**, Dublin; **Kenneth E. Morris**, Dublin; **Walton E. Sparks**, Dublin, all of Ohio; **Rickie L. Gunderson**, Greenville, Mich.

4,571,953 2/1986 Caruso 62/339
 4,580,542 4/1986 Kawabata .
 4,764,275 8/1988 Robichaud .
 4,808,302 2/1989 Beall, Jr. .
 4,815,497 3/1989 Pick .
 4,839,037 6/1989 Bertelsen et al. .

(List continued on next page.)

[73] Assignee: **White Consolidated Industries, Inc.**,
Cleveland, Ohio

FOREIGN PATENT DOCUMENTS

3-230069 10/1991 Japan .
 5-149663 6/1993 Japan .

[*] Notice: This patent is subject to a terminal disclaimer.

Primary Examiner—William Doerrler
Attorney, Agent, or Firm—Pearne, Gordon, McCoy & Granger LLP

[21] Appl. No.: **09/006,062**

[22] Filed: **Jan. 12, 1998**

[57] ABSTRACT

Related U.S. Application Data

[62] Division of application No. 08/587,635, Jan. 17, 1996, Pat. No. 5,707,518.

[51] **Int. Cl.**⁶ **F25D 23/12**

[52] **U.S. Cl.** **62/338; 62/67; 62/389; 210/416.3; 210/444**

[58] **Field of Search** 62/338, 339, 389, 62/67; 210/416.3, 444, 443, 323, 238, 455, 497.01

A water filter assembly mounted to an inner surface of a refrigerator and accessible from within a refrigeration compartment of the refrigerator. The filter assembly includes a first housing part, a second housing part, and a replaceable filter cartridge. The first and second housing parts cooperate to define a fluid-tight chamber for receipt of the filter cartridge. The first housing part includes an inlet port through which unfiltered water may be introduced into the chamber and an outlet port through which filtered water may exit the chamber. The second housing part surrounds a portion of the first housing part and provides a volume sufficient to hold the filter cartridge and any water within the chamber when the second housing part is released from the first housing part to replace the filter cartridge, and thereby prevents or minimizes spillage of water from the filter assembly during filter cartridge replacement. A shield member is disposed within the refrigeration compartment and cooperates with a cabinet wall to define a filter compartment which surrounds the filter assembly. A heater disposed within the filter compartment adjacent the filter assembly and is operable to heat the filter assembly to prevent freezing of water contained therein.

[56] References Cited

U.S. PATENT DOCUMENTS

2,567,062 9/1951 Edelen .
 2,622,738 12/1952 Kovacs .
 3,122,501 2/1964 Hultgren .
 3,146,606 9/1964 Grimes et al. .
 3,367,127 2/1968 Walker 62/353
 3,982,406 9/1976 Hanson et al. 62/339
 4,172,798 10/1979 Kronsbein .
 4,529,866 7/1985 Leary .
 4,556,484 12/1985 Hunter et al. .
 4,561,979 12/1985 Harms et al. .

30 Claims, 6 Drawing Sheets

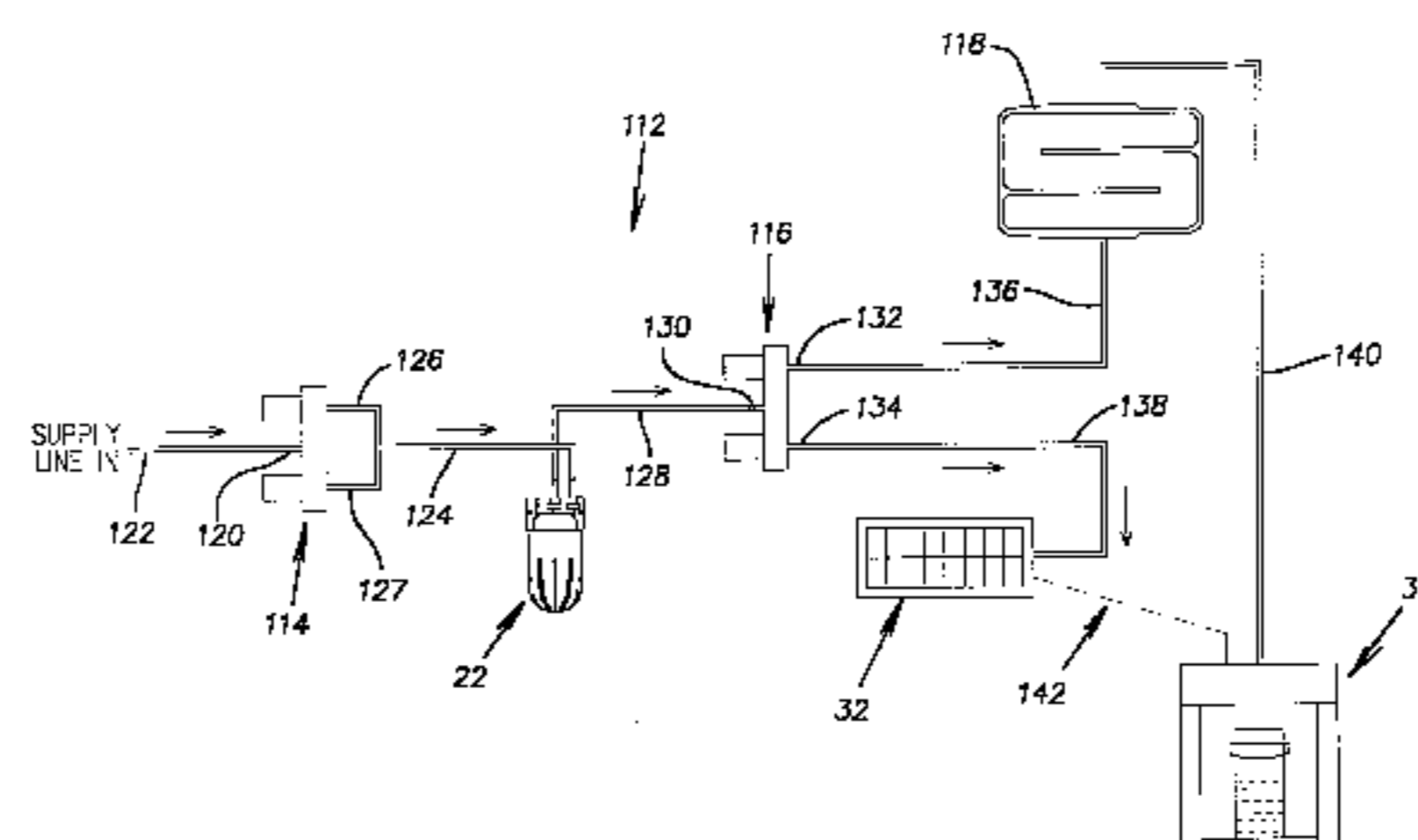
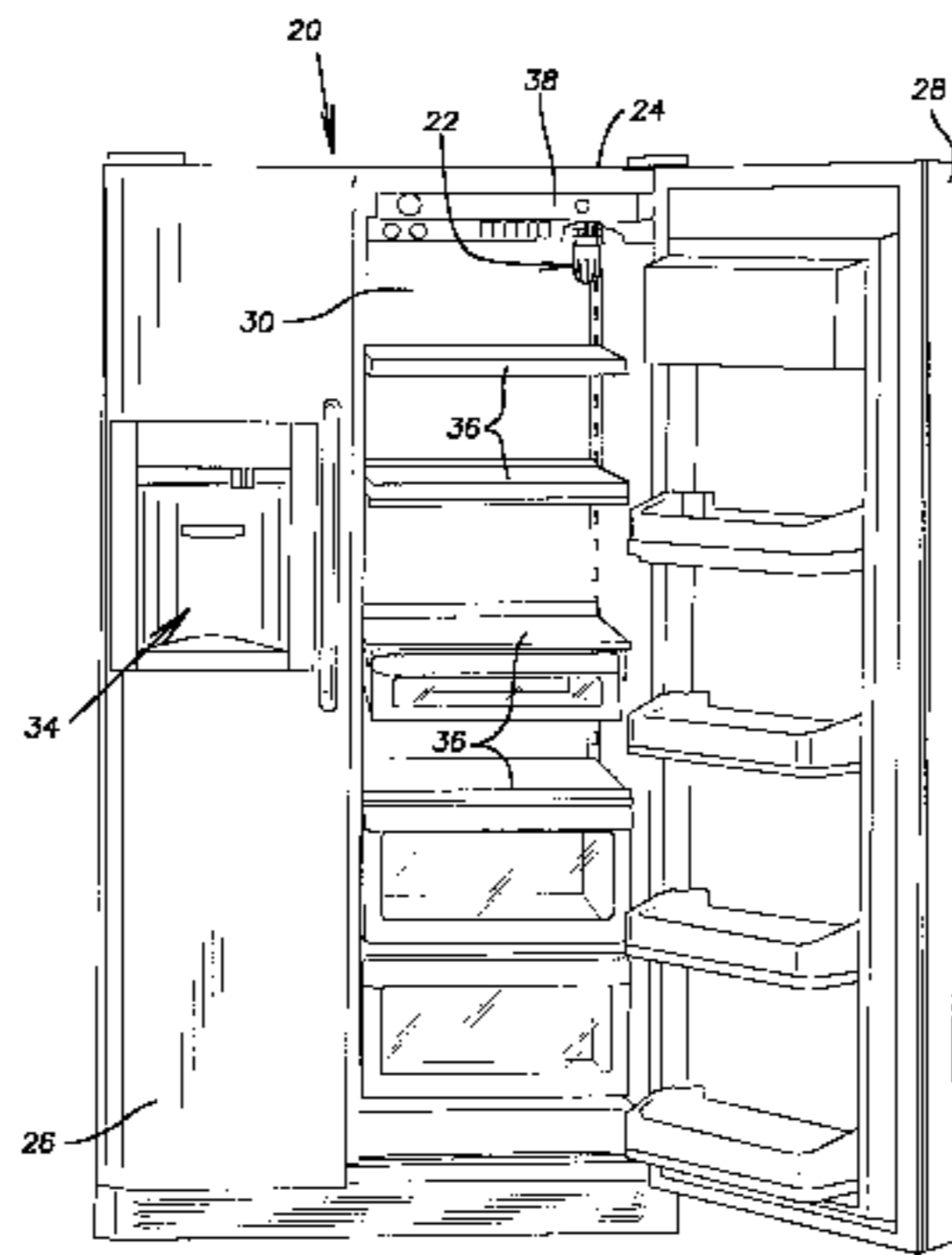

U.S. PATENT DOCUMENTS

4,859,320	8/1989	Beall, Jr. .	5,171,430	12/1992	Beach et al. .
4,866,250	9/1989	Pasbrig .	5,200,067	4/1993	Sann .
4,915,831	4/1990	Taylor .	5,269,154	12/1993	Schmidt .
5,013,434	5/1991	Furrow .	5,290,442	3/1994	Clack .
5,049,269	9/1991	Shah .	5,336,406	8/1994	Stanford et al. .
5,083,442	1/1992	Vlock 62/338	5,445,734	8/1995	Chen .
5,122,272	6/1992	Iana et al. .	5,454,944	10/1995	Clack .
5,133,858	7/1992	Walz et al. .	5,490,547	2/1996	Abadi et al. 141/359
5,135,645	8/1992	Sklenak et al. 210/97	5,707,518	1/1998	Coates et al. 210/232
			5,715,699	2/1998	Coates 62/338

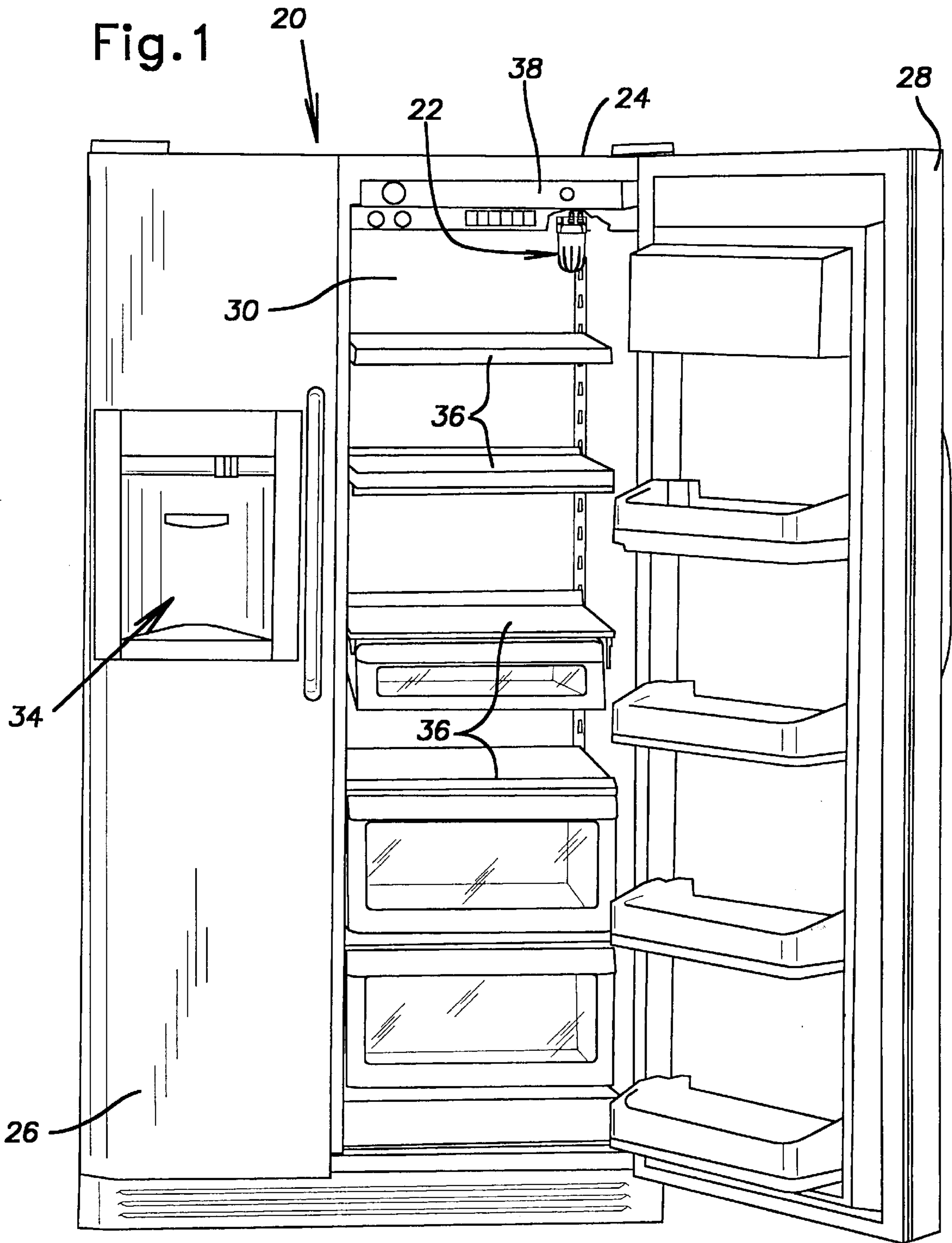

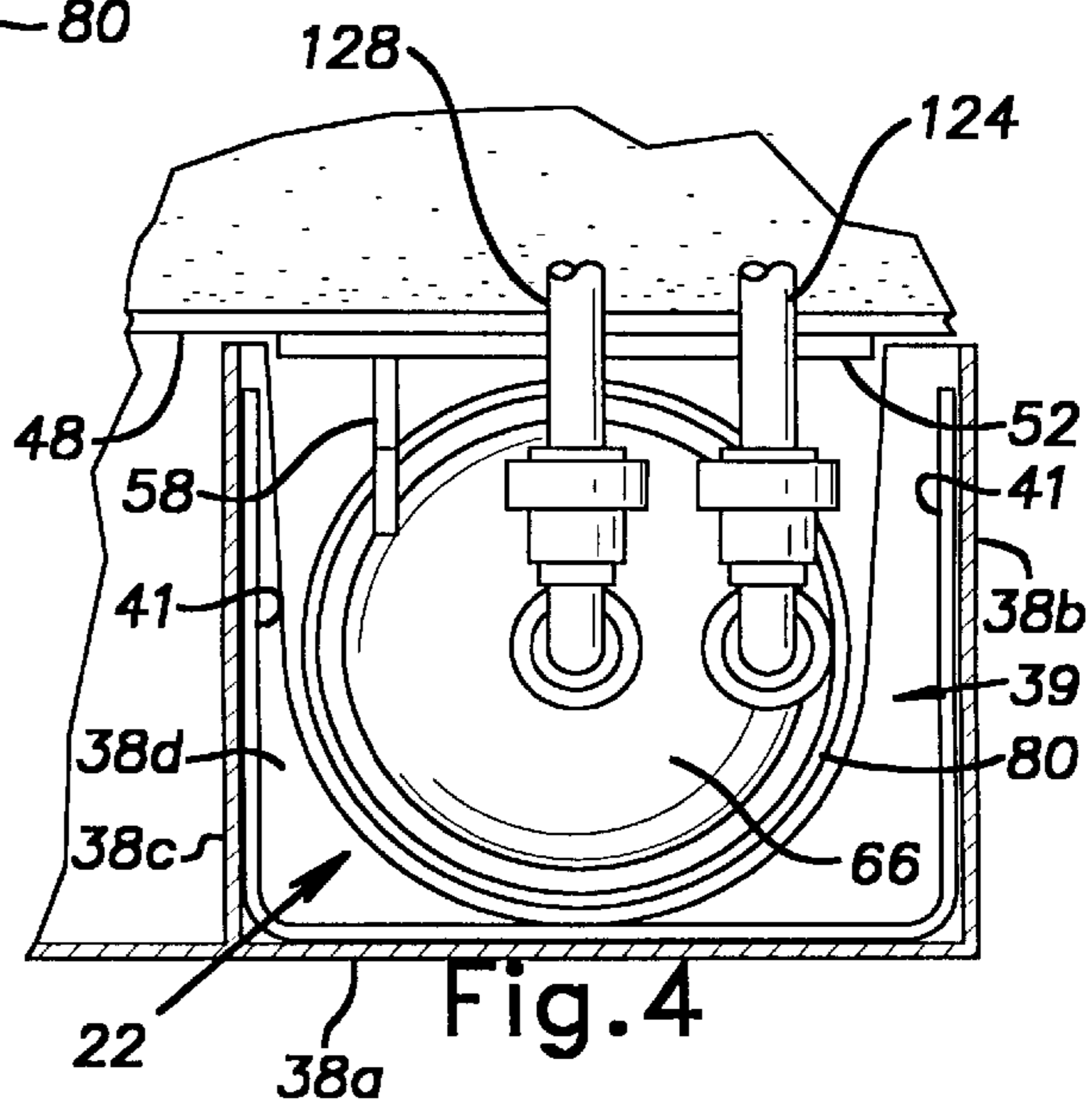
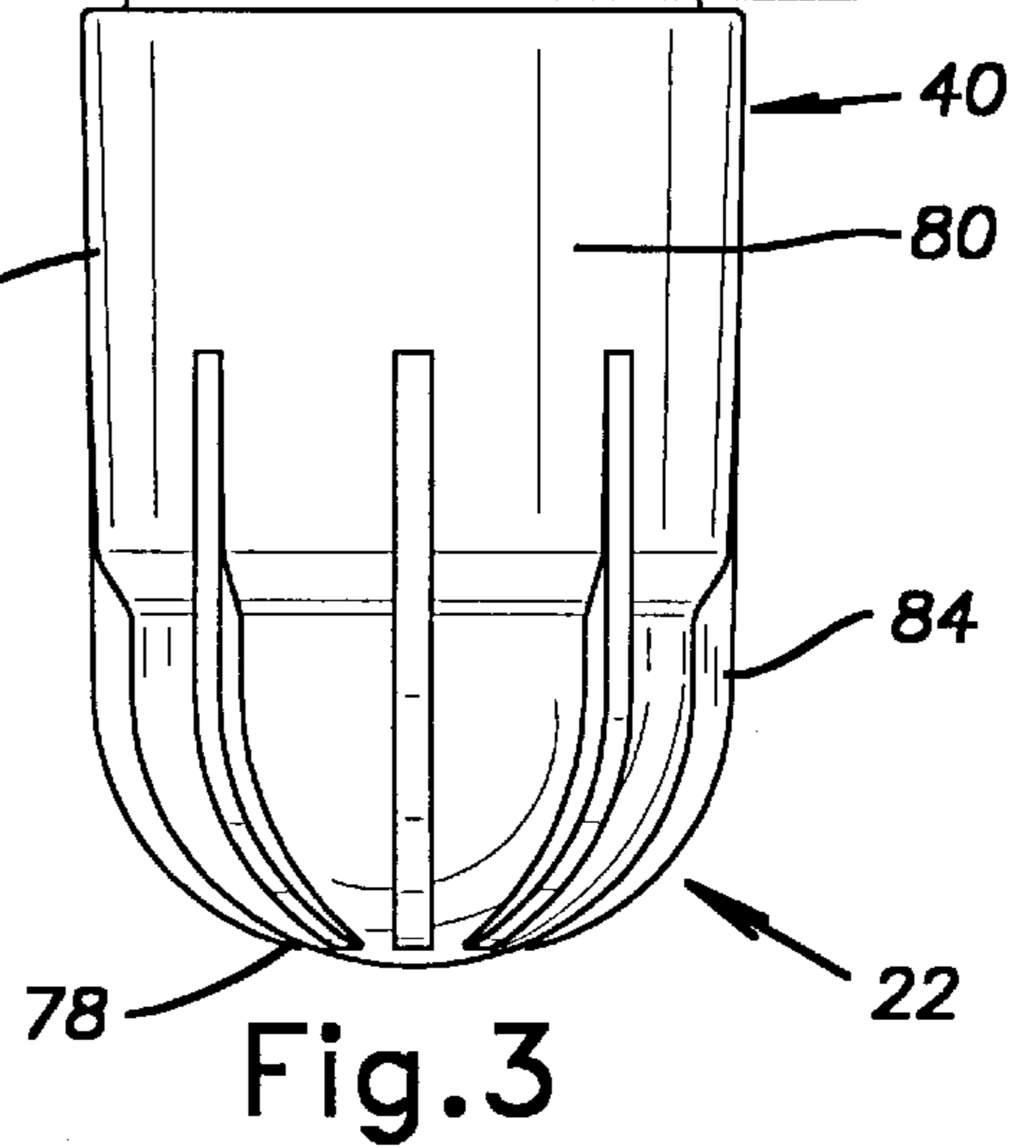
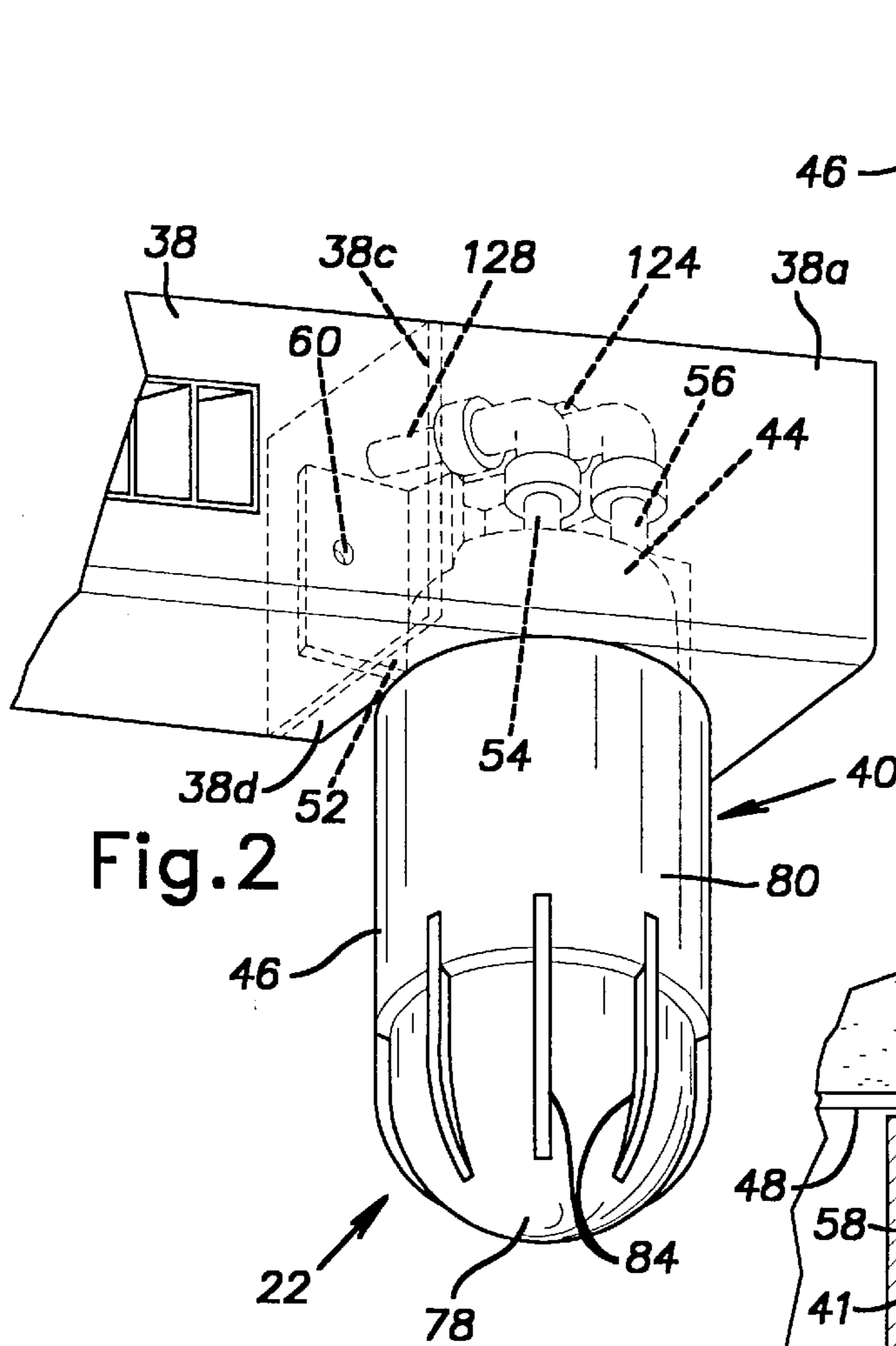
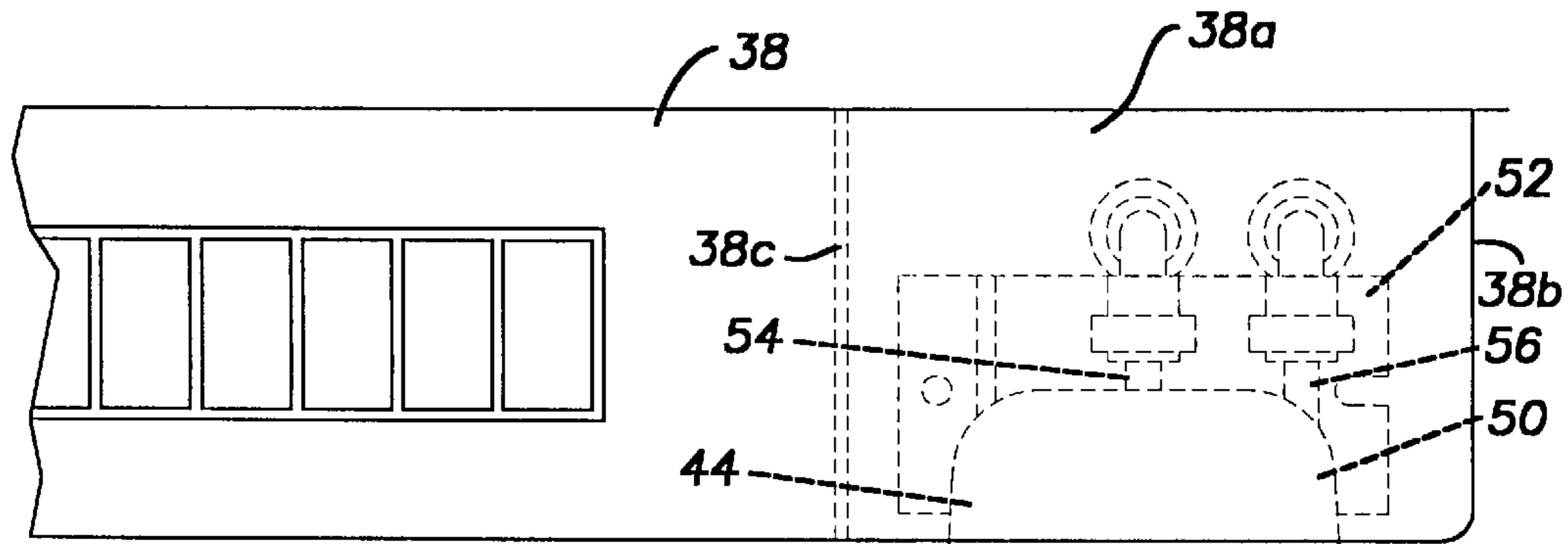

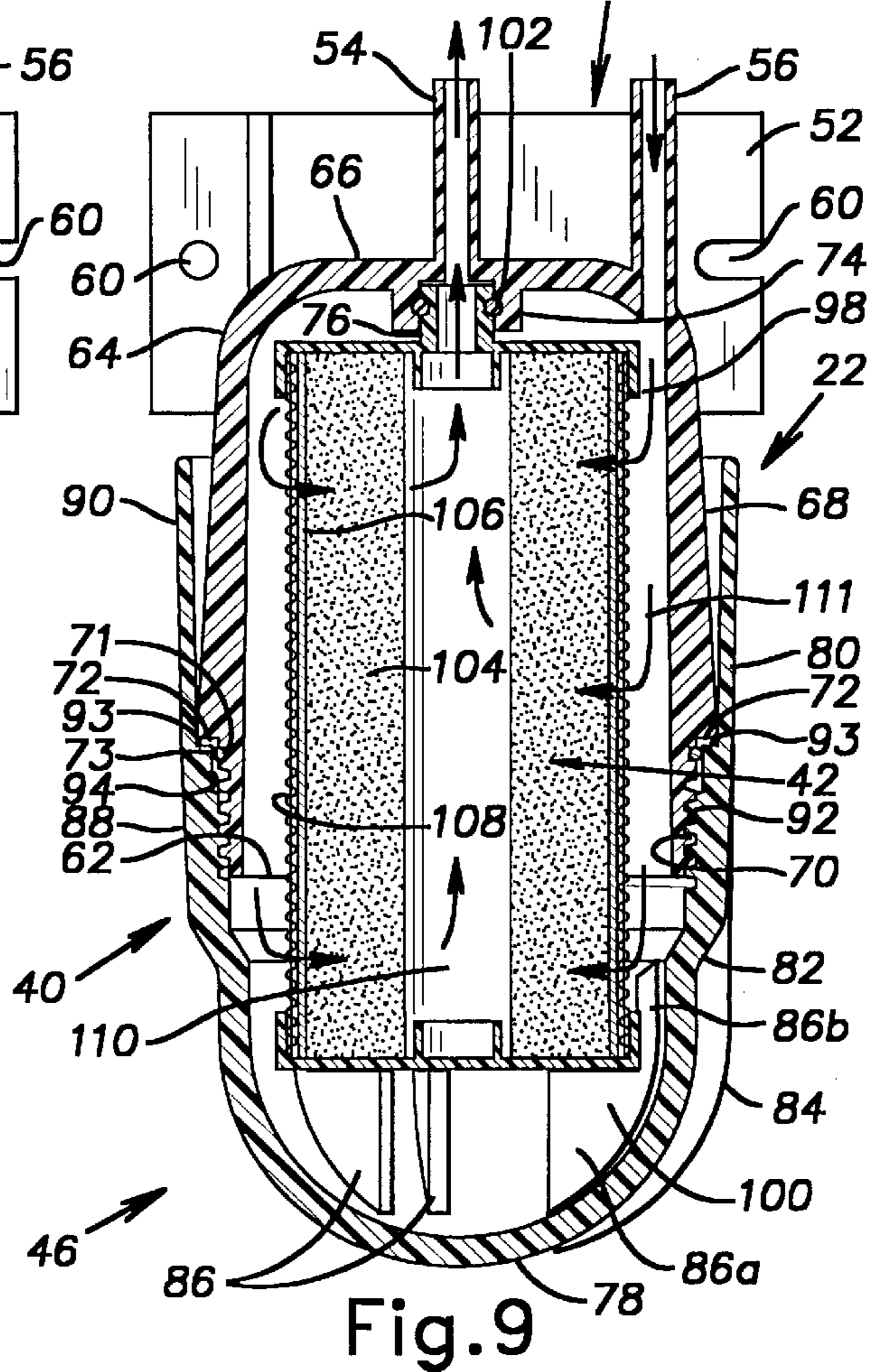
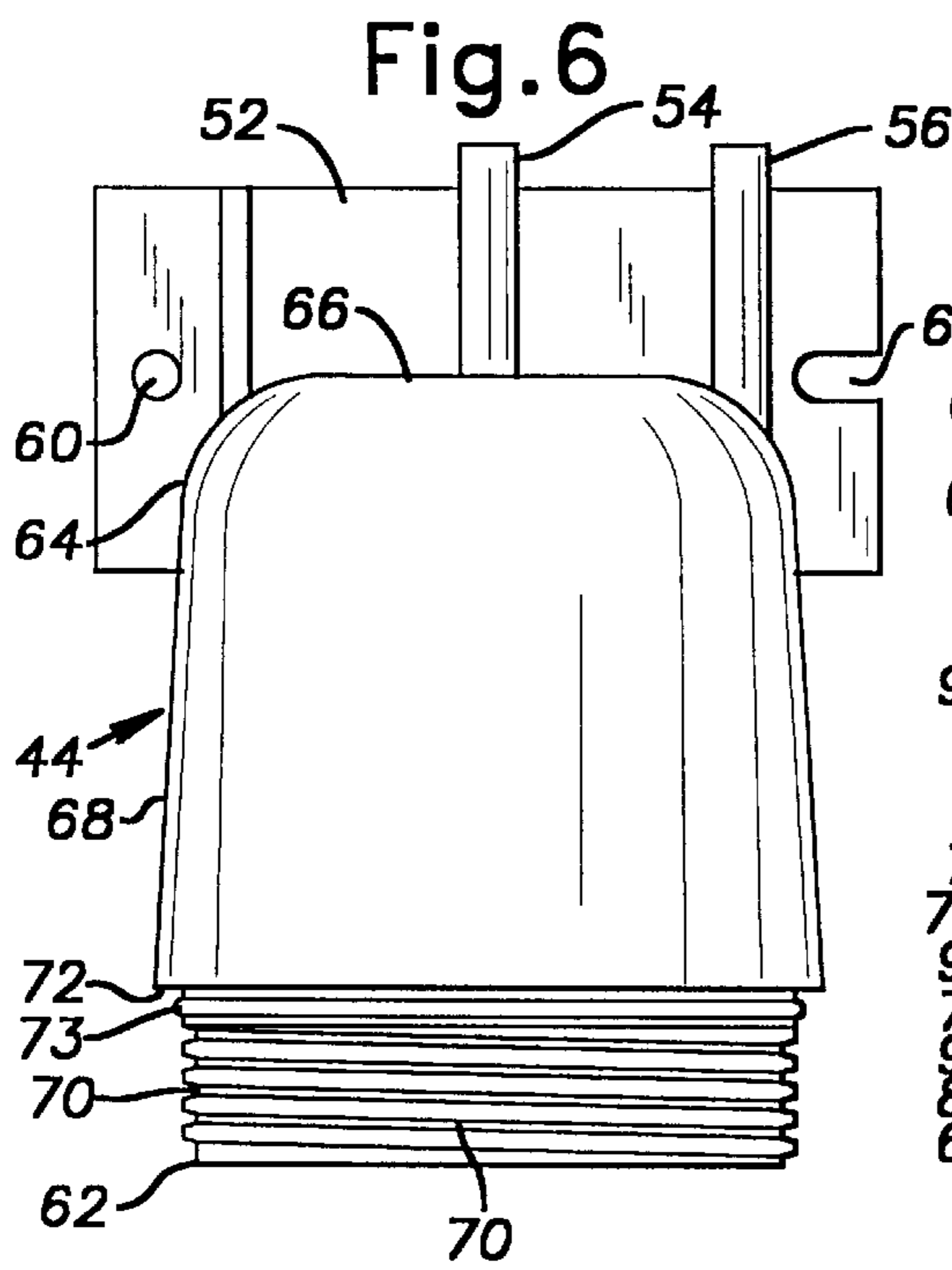
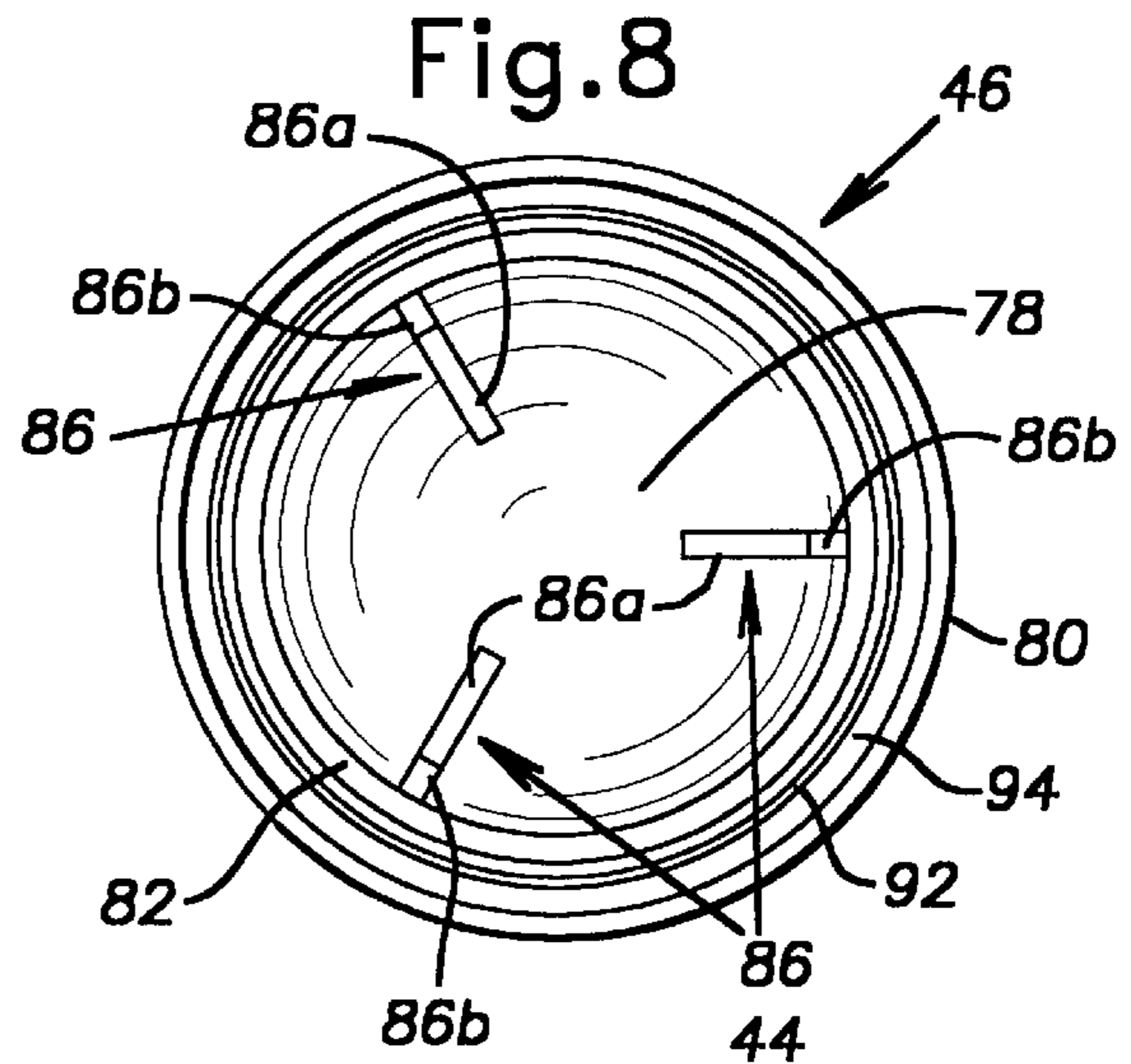
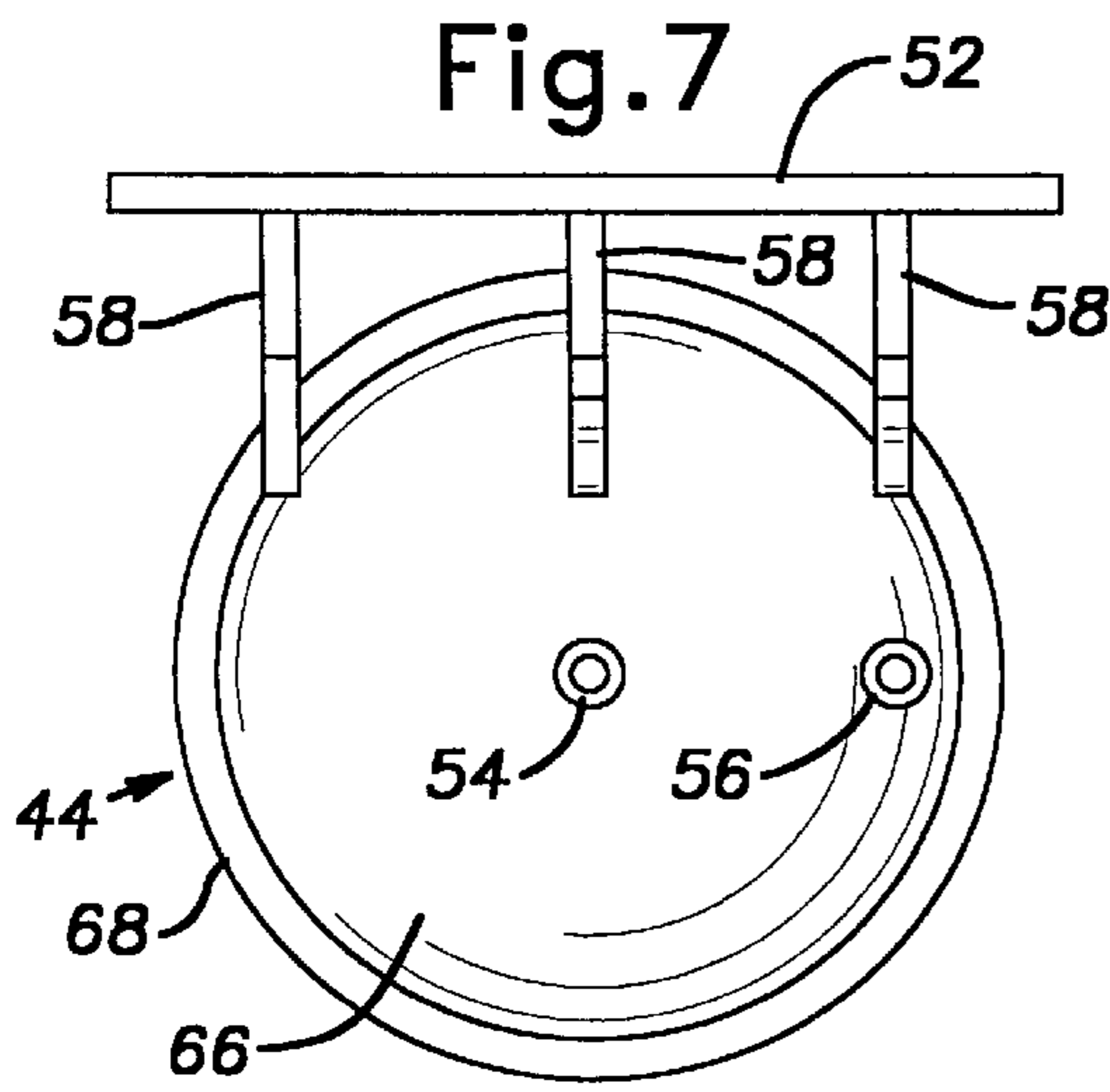

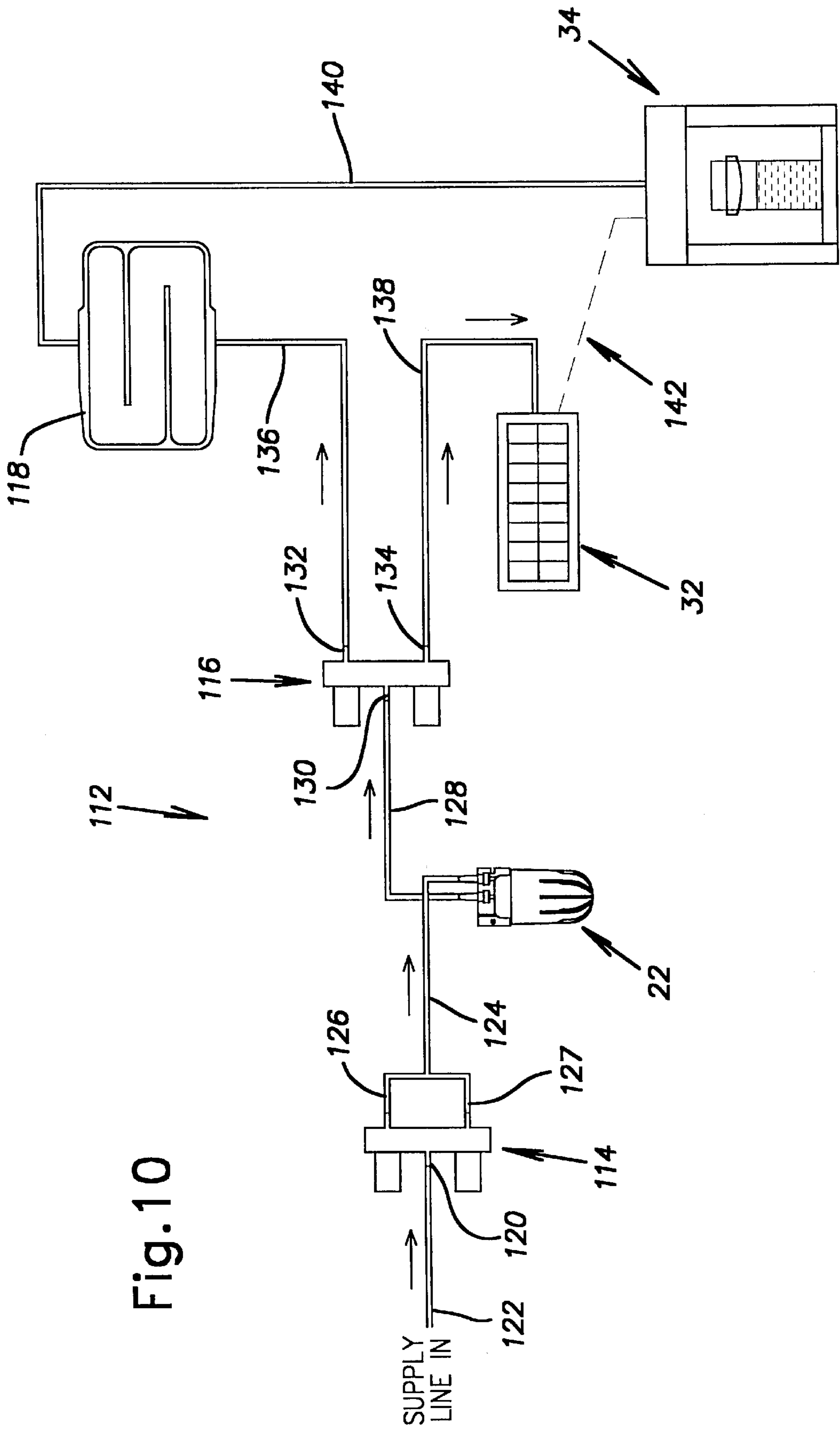
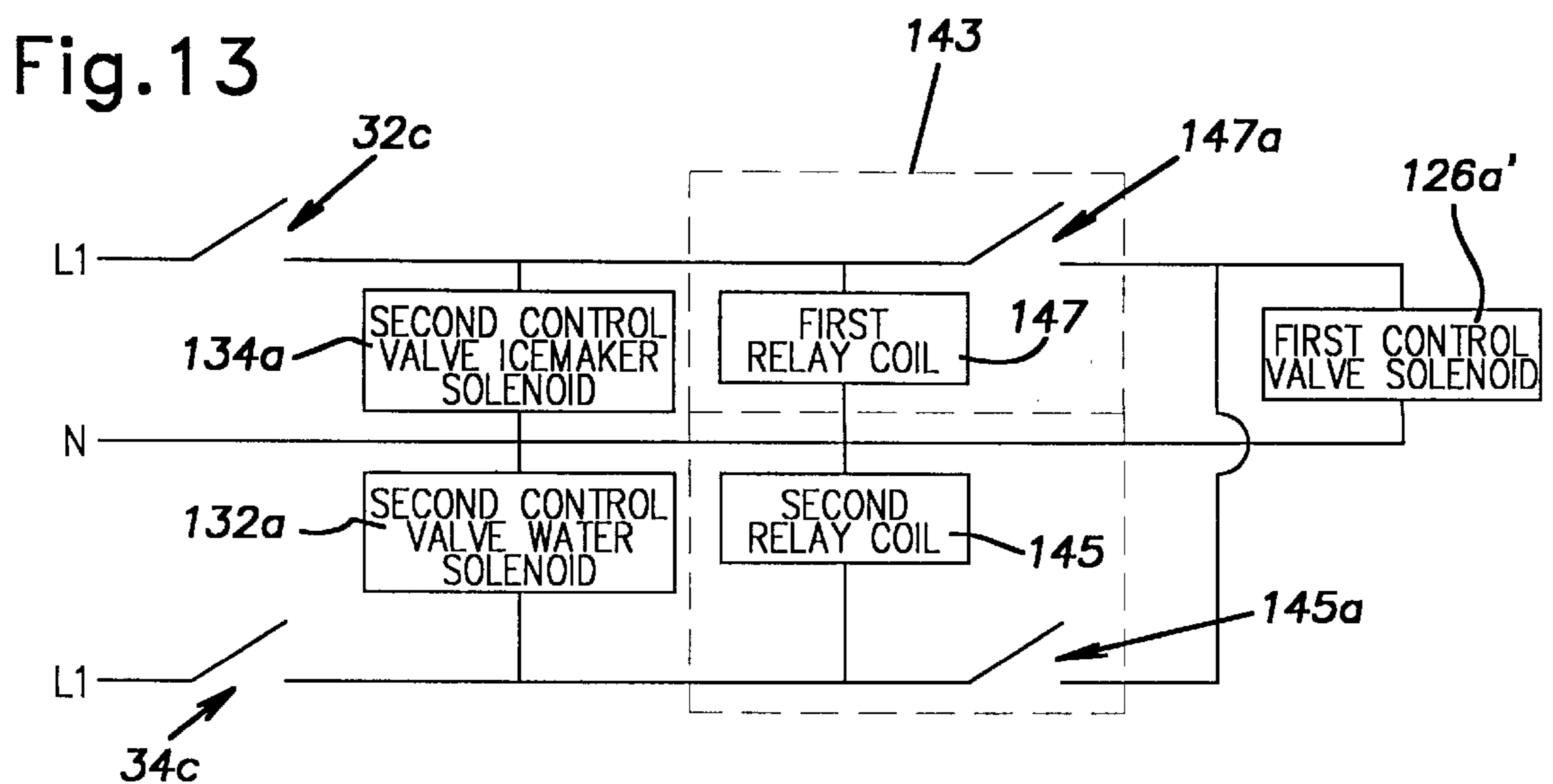
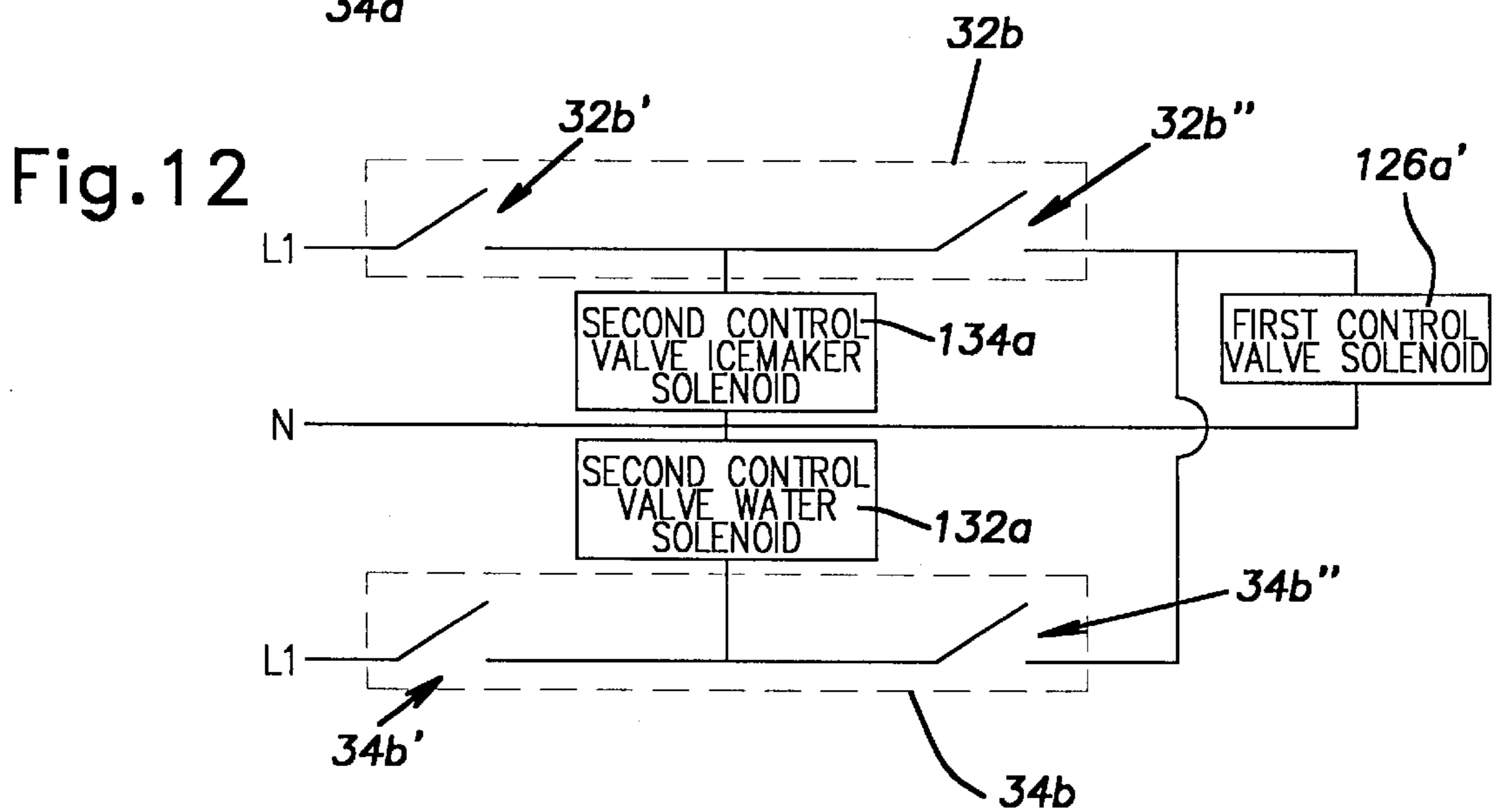
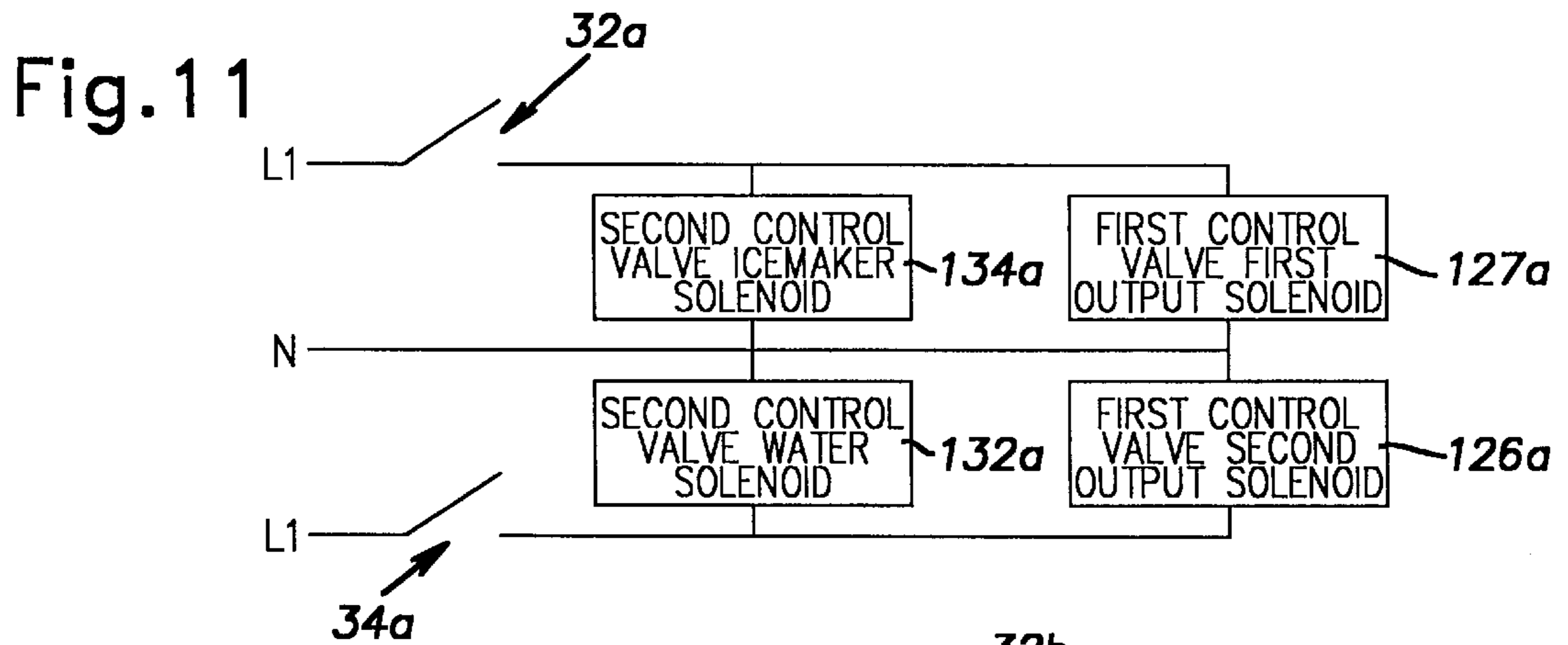

Fig. 10



REFRIGERATOR WATER FILTER
CROSS-REFERENCE TO RELATED
APPLICATIONS

The present application is a division of application Ser. No. 08/587,635, filed Jan. 17, 1996, which issued on Jan. 13, 1998, as U.S. Pat. No. 5,707,518, and is also related to application Ser. No. 08/739,256, filed Oct. 30, 1996, which has been allowed.

BACKGROUND OF THE INVENTION

1. Field of the Invention

The present invention relates to water filters and, more particularly, to refrigerator mounted water filters.

2. Description of Related Art

In recent years, as the public has begun to realize the benefits derived from drinking water and, preferably, highly pure water, there has been a great increase in the sale and availability of household water filtration devices. Concurrently, refrigerator mounted water dispensers and automatic ice makers have become more affordable, and more commonplace. In response to this fact, there have been attempts to incorporate water filters into household refrigerators to provide a filtered water supply for direct dispensing via the refrigerator water dispenser, or for use in making ice cubes via an automatic ice maker.

U.S. Pat. No. 5,135,645 discloses one attempt to incorporate a water filter into a refrigerator. The '645 patent teaches mounting the water filter within a compartment accessible via a door from the inside of the refrigerator compartment. The filter is formed as a replaceable cartridge having a cylindrical body from which inlet and outlet lines extend. A valve is operated by a manual switch, by removal of the filter cartridge, by opening the refrigerator door, or by opening the filter compartment door, to cut off the water supply to the filter. It is felt that the filtration system disclosed in the '645 patent is undesirable in that the filter cartridge must be mechanically disassembled from the water lines for replacement, which may be difficult for the user. It is also felt that concealing the filter cartridge may cause the user to forget to periodically replace the cartridge. It is also felt that the switches and shut off valves required by the '645 system introduce manufacturing costs to the resulting refrigerator which may render it cost-prohibitive, except on the most expensive refrigerator models.

U.S. Pat. No. 4,571,953 discloses a refrigerator having a water filtration unit. The water filtration unit includes a pair of chambers or filters which receive tap water and supply filtered water to a dispensing pipe extending from a top of the refrigerator. The '953 refrigerator is basically dedicated to providing a filtered cold water supply, and does not provide sufficient storage space required for a household refrigerator. See also, U.S. Pat. Nos. 4,859,320 and 4,808,302.

U.S. Pat. No. 5,083,442 discloses a refrigerator combined with a reverse-osmosis water purification system. The purification system is positioned external of the refrigerated compartment. U.S. Pat. No. 3,982,406 also provides an external filtration system for a refrigerator.

Despite the progress in the art exemplified by the foregoing patents, there exists a need in the art for a water filtration system for a household refrigerator which is accessible from within the refrigeration compartment, and which includes a filter cartridge that is easily replaceable.

SUMMARY OF THE INVENTION

The present invention provides an improved water filtration system for a household refrigerator. The system

includes a water filter assembly which is accessible from within a refrigeration compartment of the refrigerator, and which includes an easily accessed and replaced filter cartridge.

In accordance with the present invention, a filter assembly includes a first housing part, a second housing part, and a replaceable filter cartridge. The first housing part and second housing part cooperate to define a chamber for receipt of the filter cartridge.

In further accordance with the present invention, the first housing part is secured to an internal surface of the refrigerator cabinet and includes an inlet port through which unfiltered water may enter the chamber and an outlet port through which filtered water may exit the chamber. The second housing part is releasably secured to the first housing part in a fluid tight manner.

In further accordance with the present invention, the second housing part has a bowl-shaped bottom portion from which a cylindrical sidewall extends upwardly. The cylindrical sidewall radially surrounds a portion of the first housing part. A threaded inner surface of the cylindrical sidewall is threaded onto the first housing part to releasably secure the first and second housing parts together in a fluid tight manner.

In further accordance with the present invention, a portion of the filter assembly is disposed within a filter compartment. A heater is provided within the filter compartment and is operable to heat the filter assembly and thereby prevent freezing of the water within the filter assembly.

In further accordance with the present invention, a water filtration and dispensing method includes providing first and second water control valves and a water filter assembly, wherein the first water control valve is upstream of the inlet to the water filter assembly and the second water control valve is downstream of an outlet of the water filter assembly. The water control valves are opened to permit dispensing of water, and can be sequentially closed such that the first water control valve closes slightly before the second water control valve to reduce the water pressure experienced by the filter assembly.

BRIEF DESCRIPTION OF THE DRAWINGS

These and further features of the present invention will be described hereafter with reference to the following description and drawings, wherein:

FIG. 1 is a perspective view of a household refrigerator incorporating a filter assembly according to the present invention;

FIG. 2 is a perspective view of a portion of the household refrigerator and the filter assembly of the present invention;

FIG. 3 is a front elevational view of the filter assembly and a portion of the refrigerator;

FIG. 4 is a top plan view of the filter assembly secured to the refrigerator;

FIG. 5 is an exploded perspective view of a filter assembly according to the present invention;

FIG. 6 is a front elevational view of an upper part of the filter housing according to the present invention;

FIG. 7 is a top plan view of the filter housing upper part shown in FIG. 6;

FIG. 8 is a top plan view of a lower part of the filter housing according to the present invention;

FIG. 9 is a cross-sectional view of the filter assembly according to the present invention;

FIG. 10 is a schematic illustration of a water supply circuit for a household refrigerator incorporating the filter assembly of the present invention;

FIG. 11 is a schematic illustration of a control circuit for the water supply circuit illustrated in FIG. 10;

FIG. 12 is a schematic illustration of a first alternative control circuit according to the present invention; and,

FIG. 13 is a schematic illustration of a second alternative control circuit according to the present invention.

DETAILED DESCRIPTION OF THE PREFERRED EMBODIMENT

With reference to the drawing figures and, in particular, FIG. 1, a refrigerator 20 incorporating a filter assembly 22 according to the present invention is illustrated. The illustrated refrigerator includes a cabinet 24 having a plurality of insulated walls. A freezer door 26 and a refrigerator door 28 are pivotally mounted to the cabinet 24 and cooperate with the cabinet to define a freezer compartment (not shown) and a refrigeration compartment 30. The illustrated refrigerator 20 is commonly known in the art as a "side-by-side" refrigerator.

Naturally, it is contemplated that the filter assembly 22 of the present invention is useful in other types of refrigerators, such as ones wherein the freezer and refrigeration compartments are vertically offset relative to one another. Furthermore, although the following discussion is based upon incorporation of the filter assembly into a refrigerator which, as illustrated in FIG. 1 and schematically shown in FIG. 10, includes an automatic ice maker 32 and a freezer-door mounted ice and water dispenser 34, it is considered apparent that the filter assembly could be used in refrigerators that do not include an automatic ice maker, and in refrigerators wherein the ice and/or water dispenser is not accessible from an exterior of the refrigerator.

As shown in FIG. 1, the refrigeration compartment 30 is generally rectangular in configuration, and has a series of shelves 36 mounted therein for storage of foodstuffs. At an upper, rear portion of the refrigeration compartment a shield 38 is provided to which various controls (not shown) for regulating operating conditions of the refrigerator 20 may be mounted. The filter assembly 22 is partially concealed and surrounded by the shield 38, as illustrated in FIGS. 2-3.

The shield 38 includes a front wall 38a, a lateral side wall 38b, a partition wall 38c, and a bottom wall 38d which cooperate with a rear wall 48 of the cabinet 24 to define a filter compartment 39 which receives a portion of the filter assembly 22. The bottom wall 38d defines an opening through which the filter assembly 22 extends, as illustrated.

A thin film-type electrical resistance heater 41 is secured to inner surfaces of the front, lateral, and partition walls 38a, 38b, 38c, and serves to heat the shield 38, air within the filter compartment 39, the filter assembly 22, and water lines disposed within the filter compartment 39. Thus, the heater 41 prevents freezing of water within the filter assembly 22 and associated water lines, as will be apparent from the discussion to follow.

With reference to FIGS. 2-9, the filter assembly 22 includes a filter housing 40 and a replaceable filter cartridge 42. The filter housing 40 includes a first housing part 44 and a second housing part 46. The first housing part is preferably secured to the rear wall 48 of the cabinet 24 and, more preferably, is located in a rear and upper corner of the refrigeration compartment 30. The first housing part 44 is generally received within the filter compartment 39, and

projects downwardly through the opening in the shield bottom wall 38d, as illustrated.

The first housing part 44 includes a main body 50 from which a mounting bracket 52, an outlet port connector 54, and an inlet port connector 56 integrally extend. The mounting bracket 52 is integrally connected to the main body 50 by a series of connecting webs 58, as illustrated. A pair of mounting apertures 60 are formed in the mounting bracket 52 to facilitate attachment of the bracket to the rear wall 48 of the cabinet 24 by mechanical fasteners, such as screws (not shown). Naturally, it is contemplated that various other means of mechanical attachment may be employed to secure the first housing part 44 to the refrigerator cabinet 24 without departing from the scope and spirit of the present invention. For example, snap-lock or bayonet-type connectors could be used in place of more conventional mechanical fasteners.

As shown best in FIGS. 5-7 and 9, the main body 50 of the first housing part 44 is generally cup-shaped, being open at its lower end 62, closed at its upper end 64 by an end wall 66, and having a generally cylindrical sidewall 68. The outlet port connector 54 projects from the end wall 66 and is generally co-axial with the sidewall 68 of the first housing part main body 50. The inlet port connector 56 also projects from the end wall 66, but is radially spaced from the common axis of the sidewall 68 and the outlet port connector 54, as illustrated.

The sidewall 68 of the first housing part main body 50 gradually increases in thickness as it extends downwardly away from the end wall 66. The outer periphery of the sidewall 68 is gradually sloped, while the inner diameter is generally constant, as illustrated.

At the lower end 62 of the main body 50, the sidewall 68 includes a reduced-thickness, externally threaded portion 70, a circumferential groove 71, and a downwardly-facing annular surface 72. The circumferential groove 71 receives an O-ring 73. The threaded portion 70 and the O-ring 73 cooperate with the second housing part 46 to permit fluid tight connection of the second housing part 46 to the first housing part 44, as will be described more fully hereafter.

The end wall 66 of the first housing part main body 50 has a mounting ring 74 projecting downwardly from an inner surface thereof. The mounting ring 74 is coaxial with the outlet port connector 54, and cooperates with an outlet connector 76 of the filter cartridge 42 to seal the filter cartridge outlet to the first housing part 44 and prevent unfiltered water from bypassing the filter cartridge 42, as will be apparent from the discussion to follow.

As shown best in FIGS. 5, 8 and 9, the second housing part 46 includes a bowl-shaped lower portion 78 and an upstanding, generally cylindrical sidewall 80 which are interconnected by a short frustoconical portion 82. A series of external ribs 84 are formed on the second housing part 46 to enhance gripping of the second housing part by the user, as will be necessary for the user to turn the second housing part 46 relative to the first housing part 44 during assembly and disassembly.

The bowl-shaped portion 78 of the second housing part also has a series of ribs 86 formed on an internal surface thereof to aid in locating and supporting the filter cartridge 42 during assembly. The ribs 86 include a first part 86a and a second part 86b. The first parts 86a of the ribs 86 define a horizontal support surface for the filter cartridge 42. The second parts 86b extend upwardly from the first parts 86a, and define vertical surfaces which radially surround and support the filter cartridge 42.

The sidewall 80 of the second housing part 46 includes a lower or first portion 88 and an upper or second portion 90,

as shown best in FIG. 9. The first portion 88 is relatively thicker than the second portion 90, and includes a threaded inner surface 92, an upwardly facing annular surface 93, and an annular sealing surface 94. The threaded inner surface 92 is threadably received by the externally threaded portion 70 of the first housing part 44. The upwardly facing annular surface 93 of the second housing part 46 is adjacent the downwardly facing annular surface 72 of the first housing part. The annular sealing surface 94 engages the O-ring 73 to provide a fluid-tight seal between the housing parts 44, 46.

As shown in FIGS. 5 and 9, the filter cartridge 42 includes a cylindrical filter body 96 and upper and lower end caps 98, 100. The upper and lower end caps 98, 100 cover the ring-shaped ends of the filter body 96, and extend along the cylindrical sides of the filter body 96 a short distance, as illustrated in FIG. 9.

The upper end cap 98 has the outlet connector 76 projecting upwardly therefrom. The outlet connector 76 is generally coaxial with the filter body 96 and extends into the downwardly extending mounting ring 74 provided by the first housing part end wall 66. Preferably, the outlet connector 76 has a circumferential groove which receives an O-ring 102 to sealingly attach the upper end cap 98 of the filter cartridge 42 to the first housing part 44, and thereby prevents unfiltered water from bypassing the filter cartridge, as mentioned previously.

The lower end cap 100 is engaged and supported by the ribs 86 extending from the inner surface of the bowl-shaped portion 78 of the second housing part 46. The first parts 86a of the ribs 86 engage the circular bottom surface of the lower end cap 100 and vertically support the filter cartridge 42. The second parts 86b of the ribs radially surround the lower end cap 100, and radially align or orient the filter cartridge 42.

During assembly, as will be described hereafter, the ribs 86 engage the lower end cap 100 to support the filter cartridge 42 while the second housing part 46 is being threaded onto the first housing part 44. The ribs 86 serve to properly position and align the filter cartridge 42 such that the outlet connector 76 is inserted into the mounting ring 74.

The cylindrical filter body 96 preferably has a multi-material construction, including an inner cylinder of compressed or extruded carbon 104, an intermediate layer of fiber floss 106, and an outer mesh wrap 108. A longitudinal bore 110 extends the length of the filter body 96 and is in fluid communication with the outlet connector 76 and the outlet port connector 54.

Water is introduced through the inlet port connector 56 into a chamber 111 defined by the first and second housing parts and in which the filter cartridge 42 is disposed. The unfiltered water is filtered as it flows radially inwardly through the filter body 96 and toward the longitudinal bore 110. The filtered water thereafter flows upwardly through the bore 110, through the outlet connector 76 and out the outlet port connector 54. Naturally, it is contemplated that other types or styles of filter cartridges may be interchanged with the preferred and illustrated filter cartridge 42 without departing from the scope and spirit of the present invention.

During assembly, and with the first housing part 44 secured to the rear wall 48 of the cabinet 24, the filter cartridge 42 is inserted into the first housing part 44 such that the outlet connector 76 extends into the mounting ring 74 provided by the first housing part end wall 66 and the O-ring 102 sealingly engages an inner surface of the mounting ring 74 in a fluid-tight manner. Thereafter, the second housing part 46 is threaded onto the first housing part 44.

As the second housing part 46 is completely threaded onto the first housing part 44, the inner ribs 86 of the second

housing part engage the filter cartridge lower end cap 100 to longitudinally and radially support the filter cartridge 42, and force the filter cartridge outlet connector 76 further into the mounting ring 74. Also, the second housing part's annular sealing surface 94 is brought into sealing engagement with the O-ring 73 provided by the first housing part 44, as described briefly hereinbefore.

Alternatively, the filter cartridge 42 may first be inserted into the second housing part 46 such that the lower end cap 100 is radially and longitudinally supported by the second housing part's inner ribs 86. The second parts 86b of the ribs 86 serve to vertically and radially align the filter cartridge 42 such that, upon subsequent threaded attachment of the first and second housing parts 44, 46, the outlet connector 76 of the filter cartridge is coaxially aligned with, and inserted into, the mounting ring 74 of the first housing part, and the O-ring 102 on the outlet connector 76 sealingly engages the inner surface of the mounting ring 74 in a fluid-tight manner.

The water filter assembly 22 described above is intended for use as part of a water filtering and dispensing system 112, schematically illustrated in FIG. 10. The filtering and dispensing system 112 includes, in addition to the above-described water filter assembly 22, first and second control valves 114, 116, a filtered water storage tank 118, the automatic ice maker 32, and the combination ice/water dispenser 34.

The first control valve 114 is relatively upstream, in a direction of water flow, from the water filter assembly 22, and controls the delivery of unfiltered water to the water filter assembly 22. The first control valve 114 has an input 120 and first and second outputs 126, 127 which are opened and closed by solenoids 126a, 127a, respectively (FIG. 11).

The first control valve input 120 is connected to a source of household tap water by a household water supply line 122. The first and second outputs 126, 127 are connected to the inlet port connector 56 via an unfiltered water supply line 124. The unfiltered water supply line 124 lies within the insulated cabinet rear wall 48, and extends or projects into the filter compartment 39 a short distance, as shown in FIGS. 2-4.

A filtered water supply line 128 extends from the outlet port connector 54 of the first housing part 44 to an input 130 of the second control valve 116. Like the unfiltered water supply line 124, the filtered water supply line 128 lies within the insulated cabinet rear wall 48, and extends or projects into the filter compartment 39 a short distance (FIGS. 2-4).

The second control valve 116 has first and second outputs 132, 134 which are opened and closed by solenoids 132a, 134a, respectively (FIG. 11). The first output 132 is fluidly connected to the water storage tank 118 via a first conduit 136, and the second output 134 is connected to the ice maker 32 via a second conduit 138. Preferably, the second output 134 of the second control valve 116 includes a "flow washer" to regulate the flow of water into the ice maker 32 to provide a controlled filling thereof, as is known in the art.

An output of the water storage tank 118 is also connected to the ice/water dispenser 34 by a third conduit 140. The ice maker 32 delivers ice to the ice/water dispenser 34 via a chute 142, as is well known in the art. The ice/water dispenser 34 includes a water dispenser switch 34a. The ice maker 32 includes a switch 32a.

With reference to FIG. 11, when the ice/water dispenser 34 is actuated to dispense water, the water dispenser switch 34a is closed which, in turn, provides power to the first control valve's first solenoid 126a and to the second control valve's first solenoid 132a to open the control valves' first

outputs **126**, **132**, respectively. Opening the first outputs **126**, **132** permits the flow of unfiltered water into the filter assembly **22** and the flow of filtered water into the cold water storage tank **118** and out of the ice/water dispenser **34**.

Similarly, when the automatic ice maker **32** needs water to make more ice, the ice maker switch **32a** is closed which, in turn, provides power to the first control valve's second solenoid **127a** and to the second control valve's second solenoid **134a** to open the control valves' second outputs **127**, **134** respectively. Opening the second outputs **126b**, **132b** permits the flow of unfiltered water into the filter assembly **22** and the flow of filtered water to the ice maker **32**.

A first alternative control circuit is shown in FIG. **12**, and is adapted for use with an alternative first control valve (not shown) The alternative first control valve differs from the previously-described first control valve **114** in that it has only a single output controlled by a solenoid **126a'**. The first alternative control circuit includes, in addition to the second control valve **116** described hereinbefore and the alternative first control valve, a double-throw ice maker switch **32b** having first and second contacts **32b'**, **32b''**, and a double-throw water dispenser switch **34b** having first and second contacts **34b'**, **34b''**.

Closing the water dispenser switch **34b** closes the first and second contacts **34b'**, **34b''**, and provides power to the alternative first control valve solenoid **126a'** and to the second control valve's first solenoid **132a** to thereby open the alternative first control valve output and the first output **132** of the second control valve **116** and permit the flow of unfiltered water into the filter assembly **22** and the flow of filtered water into the cold water storage tank **118** and out of the ice/water dispenser **34**.

Similarly, closing the ice maker switch **32b** closes the first and second contacts **32b'**, **32b''**, and provides power to the alternative first control valve solenoid **126a'** and to the second control valve's second solenoid **134a** to open the alternative first control valve output and the second output **134** of the second control valve **116** and thereby permit the flow of unfiltered water into the filter assembly **22** and the flow of filtered water to the ice maker **32**.

A second alternative control circuit is shown in FIG. **13**. The circuit includes, in addition to the second control valve **116** and the alternative first control valve described hereinbefore, a single-throw ice maker switch **32c**, a single-throw water dispenser switch **34c**, and a relay **143**. The relay **143** has a first relay coil **145** controlling a first relay contact **145a** and a second relay coil **147** controlling a second relay contact **147a**.

When the water dispenser switch **34c** is closed, the first solenoid **132a** of the second control valve **132** is energized to open the second control valve's first output **132**. The first relay coil **145** is energized to close the first contact **145a** and supply power to the alternative first control valve solenoid **126a'** and thereby open the alternative first control valve. Thus, unfiltered water flows into the filter assembly **22** and filtered water flows into the cold water storage tank **118** and out of the ice/water dispenser **34**.

Similarly, when the ice maker switch **32c** is closed, the second solenoid **134a** of the second control valve **116** is energized to open the second control valve's second output **134**. The second relay coil **147** is energized to close the second contact **147a** and supply power to the alternative first control valve solenoid **126a'** and thereby open the alternative first control valve. Thus, unfiltered water flows into the filter assembly **22** and filtered water flows into the ice maker **32**.

In each case (i.e., whether the water dispenser **34** or ice maker **32** is supplied with water), the first control valve **114** is preferably closed prior to the closing of the second control valve **116**. More preferably, the first control valve **114** is closed about one second before the second control valve **116** is closed. Delaying the closure of the second control valve **116** relative to the first control valve **114** reduces the water pressure on the water filter assembly **22**, and thereby reduces the chance for failure of the filter assembly, the necessary strength of the seals and parts of the filter assembly, and the resulting cost of the filter assembly. The delayed closure of the second control valve **116** also makes disassembly of the filter housing **40** by removal of the second housing part **46** from the first housing part **44** easier by reducing the water-pressure induced tension on the filter assembly **22**.

As should be apparent from the foregoing, access to the filter cartridge **42** for replacement is gained by simply twisting or turning the second housing part **46** to unthread the second housing part **46** off the first housing part **44**. During such replacement, the second housing part's bowl-shaped lower portion **78** and sidewall **80** cooperate to define a receptacle which has an available volume sufficient to receive and contain the filter cartridge **42**, the water within the filter assembly chamber **111**, as well as any water within the unfiltered water supply line **124** and the filtered water supply line **128**. Thus, leakage or spillage of water into the refrigeration compartment **30** during filter cartridge replacement is eliminated or minimized. Once the spent filter cartridge **42** is removed, a new filter cartridge is installed in the manner described hereinbefore.

Several alternative means may be employed to notify the user that the filter cartridge **42** needs replacement. The simplest, and least expensive, is simply the reduction in the flow rate of water during dispensing, which occurs when the filter cartridge becomes clogged. Other more sophisticated devices, such as clock reminders or flow rate and pressure drop across filter monitors, with associated indicators, may also be used.

It is noted that the filter assembly **22** can be used without a filter cartridge **46** when a filtered water supply is not desired. This would be the case, for instance, when the household has a filter for all tap water, such as a household reverse-osmosis filter.

Due to the location of the water filter assembly **22** at a top rear portion of the refrigeration compartment **30**, which tends to be the warmest portion of the refrigeration compartment, the water pressure at the filter assembly **22**, and the short lengths of the unfiltered water supply line **124** and filtered water supply line **128** exposed within the filter compartment **39**, the water within the filter assembly chamber **111** and water lines **124**, **128** does not tend to freeze. However, in the illustrated and preferred embodiment, the heater **41** is provided to more completely eliminate the risk of water freezing within the filter assembly **22** and water lines **124**, **128** disposed within the refrigeration compartment **30**.

As noted briefly hereinbefore, the illustrated and preferred heater **41** is a thin film or strip-type electrical resistance heater and is attached to the inner surfaces of the shield's front, lateral, and partition walls **38a**, **38b**, **38c**. The heater **41** is preferably wired to the refrigerator compressor (not shown) so that the heater is activated when the refrigerator compressor is operating to supply cold air to the refrigeration compartment **30**. Therefore, the heater **41** warms the shield **38** and air within the filter compartment **39** at the same time cold air is being introduced into the refrigeration

compartment **30**, and thereby warms the water within the filter assembly **22**, the unfiltered water supply line **124**, and the unfiltered water supply line **128**.

The heater **41** may, alternatively, be activated automatically on an as-needed basis, via a thermostat or other controls which sense air or water temperature, may be activated periodically, or may be activated concurrent with other cycles of the refrigerator **20**, such as the defrost cycle.

While the preferred embodiment of the present invention is shown and described herein, it is apparent that numerous modifications, rearrangements, alterations, and substitutions of parts may be resorted to without departing from the scope and spirit of the present invention as defined in the claims appended hereto. For example, it is contemplated that the flow path of water within the filter assembly **22** may be altered such that unfiltered water is introduced into the longitudinal bore **110** within the filter body **96** and flows radially outwardly into the chamber **111** to an axially-displaced outlet. Alternatively, unfiltered water may be introduced into the filter chamber **111** outside a filter cartridge and flow vertically upwardly through the cartridge bottom to an axially-aligned output.

It is also contemplated, though not preferred due to spacial constraints within the refrigeration compartment **30**, that the second or lower housing part could be fixedly attached to the cabinet **24** and the first or upper housing part removably secured to the second housing part to more completely eliminate the chance for spillage of water during filter cartridge replacement.

It is also contemplated that the filter cartridge **42** could be threadably secured to the first or second housing parts **44**, **46** to provide a more positive alignment and sealing thereof, or that the filter cartridge could be integrally formed with the removable second (or first) housing part. Therefore, the scope of the present invention is not limited solely to the preferred embodiment shown and described herein, but rather includes numerous other devices that fall within the meaning of the following claims.

What is claimed is:

1. A refrigerator comprising a cabinet having a plurality of insulated walls, said plurality of walls including a side wall, an upper wall, and a rear wall, a door pivotally mounted to said cabinet and cooperating with said plurality of cabinet walls to define a refrigeration compartment, wherein an interior wall is disposed in the refrigeration compartment and is spaced forwardly from the rear wall of the cabinet, an unfiltered water supply line extends through said cabinet and into said refrigeration compartment, a water filter assembly is disposed within said refrigeration compartment and includes a mounting bracket secured to one of said rear and side walls of said cabinet at a location adjacent said upper wall and between said interior wall and said rear wall, and a filtered water supply line extends from said water filter assembly and into said cabinet, said unfiltered water supply line being connected to an inlet of said water filter assembly, said filtered water supply line being connected to an outlet of said water filter assembly and fluidly connected to a filtered water dispenser.

2. A refrigerator according to claim **1**, wherein said water filter assembly includes a filter housing and a replaceable filter cartridge, said filter housing including a first housing part and a second housing part which cooperate to define a chamber for receipt of said filter cartridge.

3. A refrigerator according to claim **2**, wherein said filter cartridge is separate from said first and second housing parts and is adapted to be removed from said filter assembly when said first and second housing parts are disconnected from one another.

4. A refrigerator according to claim **2**, wherein said first housing part includes the inlet through which unfiltered water enters the chamber and the outlet through which filtered water exits the chamber.

5. A refrigerator according to claim **2**, further comprising a second interior wall extending between the interior wall and the rear wall of the cabinet, said second interior wall defining an opening through which the first housing part extends; and

wherein said first housing part is integrally joined to the mounting bracket.

6. A refrigerator according to claim **2**, wherein said first and second housing parts are releasably secured to one another in a fluid tight manner.

7. A refrigerator according to claim **6**, wherein said second housing part radially surrounds a portion of said first housing part.

8. A refrigerator according to claim **7**, wherein said second housing part has a bowl-shaped bottom portion from which a generally cylindrical wall upwardly extends, a bottom of said cylindrical wall including a threaded inner surface which threadably engages a threaded outer surface of said first housing part to secure said first and second housing parts together.

9. A refrigerator according to claim **6**, wherein said second housing part has an available volume sufficient to receive any water within said chamber to minimize spillage when said first and second housing parts are disconnected from one another.

10. A refrigerator comprising a cabinet having a plurality of insulated walls, a door pivotally mounted to said cabinet and cooperating with said walls to define a refrigeration compartment, a water filter assembly secured to one of said walls and disposed within said refrigeration compartment, and a heater disposed within said refrigeration compartment and adjacent said water filter assembly, said heater being operable to heat said water filter assembly and thereby prevent freezing of water contained within said water filter assembly.

11. A refrigerator according to claim **10**, further comprising a shield member disposed within said refrigeration compartment and at least partially surrounding said filter assembly, wherein said shield member cooperates with at least said one of said walls to define a filter compartment and said heater is disposed within said filter compartment.

12. A refrigerator according to claim **11**, wherein said water filter assembly includes a filter housing and a replaceable filter cartridge, said filter housing including a first housing part and a second housing part which cooperate to define a chamber for receipt of said filter cartridge.

13. A refrigerator according to claim **12**, wherein a first portion of said first housing part is received within said filter compartment and a second portion of said first housing part extends through an opening in said shield, and said second housing part is secured to said second portion of said first housing part and located outside said filter compartment.

14. A refrigerator according to claim **10**, further comprising an unfiltered water supply line fluidly connected to an input of said filter assembly, and a filtered water supply line fluidly connected to an output of said filter assembly, at least a portion of said supply lines being disposed within said refrigeration compartment, and said heater being operable to prevent freezing of water within said supply lines.

15. A refrigerator according to claim **11**, further comprising an unfiltered water supply line fluidly connected to an input of said filter assembly, and a filtered water supply line fluidly connected to an output of said filter assembly, at least

a portion of said supply lines being disposed within said filter compartment, and said heater being operable to prevent freezing of water within said supply lines.

16. A refrigerator, comprising a cabinet having a plurality of insulated walls, and a door pivotally mounted to said cabinet and cooperating with said walls to define a refrigeration compartment, a shield disposed within said refrigeration compartment and delimiting at least a portion of a filter compartment, a water filter assembly secured to said cabinet and disposed within said refrigeration compartment, an unfiltered water supply line extending through said cabinet to said filter assembly, and a filtered water supply line extending from the filter assembly and into said cabinet, wherein said filter assembly includes a first portion which is disposed within said filter compartment and a second portion which extends from said filter compartment, said first portion being fluidly connected to said unfiltered water supply line and said filter water supply line.

17. A refrigerator according to claim **16**, wherein said water filter assembly includes a filter housing and a filter, said filter housing including a first housing part and a second housing part which cooperate to define a chamber in which said filter is disposed.

18. A refrigerator according to claim **16**, wherein said first housing part includes an inlet connected to said unfiltered water supply line and an outlet connected to said filter water supply line.

19. A refrigerator according to claim **17**, wherein said first housing part is at least partially disposed within said filter compartment.

20. A refrigerator according to claim **17**, wherein said shield includes a wall through which a portion of said first housing part projects, said second housing part being releasably secured to the projecting portion of said first housing part.

21. A refrigerator according to claim **16**, wherein said shield includes a plurality of walls which cooperate with at

least one of said plurality of insulated walls to define the filter compartment.

22. A refrigerator according to claim **21**, wherein at least a rear and sidewall of said refrigerator cabinet cooperate with the shield walls to define said filter compartment.

23. A refrigerator according to claim **21**, wherein one of said plurality of shield walls defines an opening through which said filter assembly extends.

24. A refrigerator according to claim **23**, wherein said water filter assembly includes a filter housing and a filter, said filter housing including a first housing part and a second housing part which cooperate to define a chamber in which said filter is disposed.

25. A refrigerator according to claim **23**, wherein said first housing part includes an inlet connected to said unfiltered water supply line and an outlet connected to said filter water supply line.

26. A refrigerator according to claim **24**, wherein said first housing part is at least partially disposed within said filter compartment.

27. A refrigerator according to claim **24**, wherein a portion of said first housing part projects through the opening in said one of said plurality of shield walls, said second housing part being connected to the projecting portion of said first housing part.

28. A refrigerator according to claim **27**, further comprising heater, said heater being disposed within said filter compartment and being operable to prevent freezing of water with and said filter assembly.

29. A refrigerator according to claim **28**, wherein said heater is an electrical resistant type heater which is secured to said shield.

30. A refrigerator according to claim **16**, wherein said first portion is concealed by said shield and said second portion is exposed and readily seen by a user looking into said refrigeration compartment.

* * * * *