

US005902731A

United States Patent [19]

Ouyang et al.

[11] Patent Number: **5,902,731**

[45] Date of Patent: **May 11, 1999**

[54] **DIAGNOSTICS BASED ON TETRAZOLIUM COMPOUNDS**

[75] Inventors: **Tianmei Ouyang**, Fremont; **Yeung Siu Yu**, Pleasanton, both of Calif.

[73] Assignee: **Lifescan, Inc.**, Milpitas, Calif.

[21] Appl. No.: **09/161,876**

[22] Filed: **Sep. 28, 1998**

[51] Int. Cl.⁶ **C12Q 1/32; C12Q 1/54; G01N 33/49; G01N 33/52**

[52] U.S. Cl. **435/26; 435/14; 435/287.7; 435/287.8; 435/962; 435/970; 436/110**

[58] Field of Search **435/26, 14, 287.7, 435/287.8, 962, 970; 436/110**

[56] **References Cited**

U.S. PATENT DOCUMENTS

4,803,158 2/1989 Shigeta et al. 435/25
5,510,245 4/1996 Magers 435/26

FOREIGN PATENT DOCUMENTS

0 638 805 A2 2/1995 European Pat. Off. G01N 33/52

OTHER PUBLICATIONS

Lindquist et al. Rapid Determination of Toxic Cyanide in Blood. *Clinical Chemistry* 35 (4), pp. 617-619. (4/1989).
Tietz Textbook of Clinical Chemistry, 2nd Ed., ed. by C. Burtis et al., W.B. Saunders Co., Philadelphia, PA, 1994, pp. 974, 976-978 and 1174-1175.

KetoSite® test (available from GDS Diagnostics, Elkhart, IN.) 12/29/93.

Hemoglobin:Molecular, Genetic and Clinical Aspects, by Franklin H.Gunn and Bernard G. Forget, W.B. Saunders Co., Philadelphia, PA, 1968, pp. 638-644.

Glucometer Encore™ Blood Glucose Test Strips, Distributed by Miles Canada, Inc., Diagnostics Division, Etobicoke, Ontario M9W 1G6, 1992.

Primary Examiner—Kathleen K. Fonda
Assistant Examiner—Marjorie A. Moran
Attorney, Agent, or Firm—James Riesenfeld

[57] **ABSTRACT**

A reagent is suitable for measuring the concentration of an analyte in a hemoglobin-containing biological fluid, such as whole blood. The reagent comprises dehydrogenase enzyme that has specificity for the analyte, NAD or an NAD derivative, a tetrazolium dye precursor, a diaphorase enzyme or an analog thereof, and a nitrite salt. The reagent causes dye formation that is a measure of the analyte concentration. The nitrite salt suppresses interfering dye formation caused non-enzymatically by the hemoglobin. Preferably, the reagent is used in a dry strip for measuring ketone bodies, such as beta-hydroxybutyrate.

14 Claims, 2 Drawing Sheets

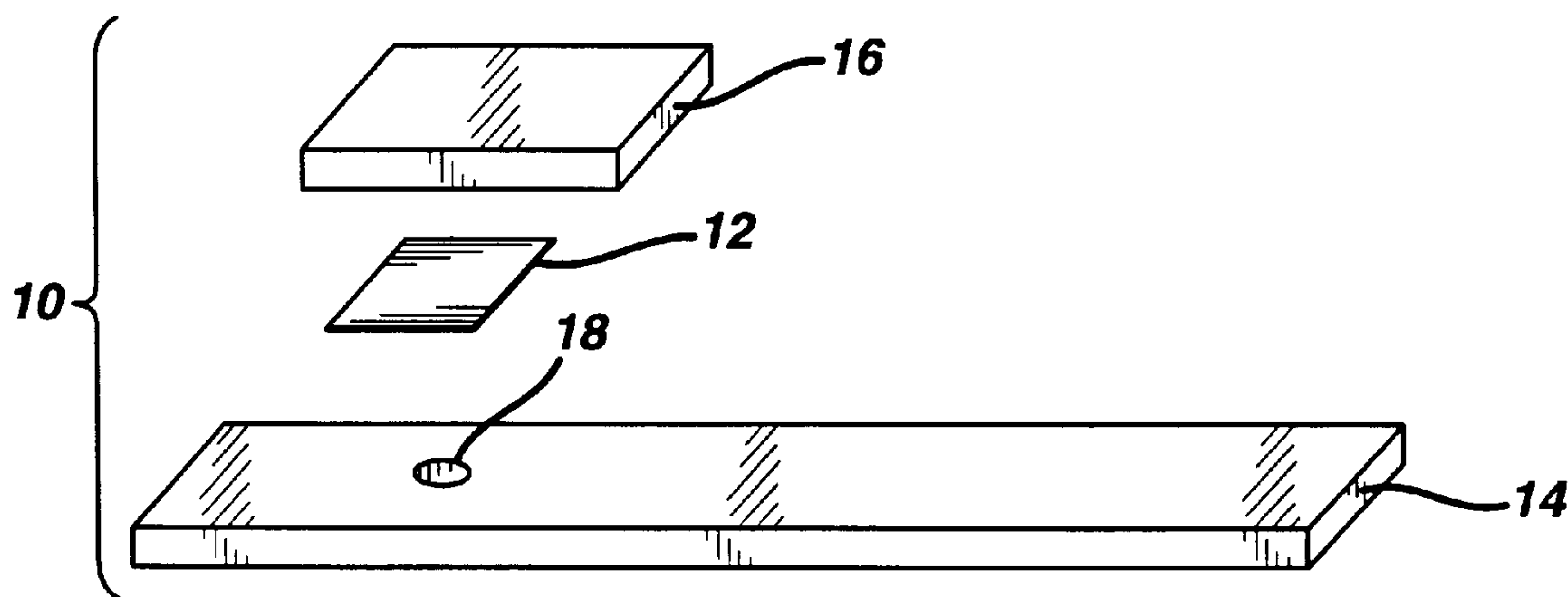

FIG. 1

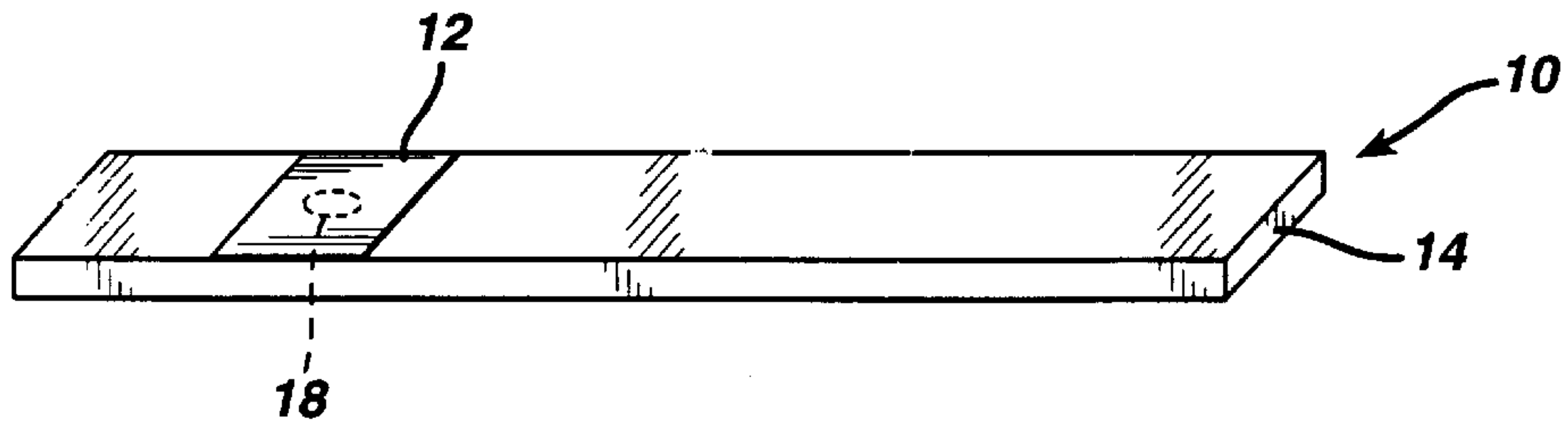

FIG. 2

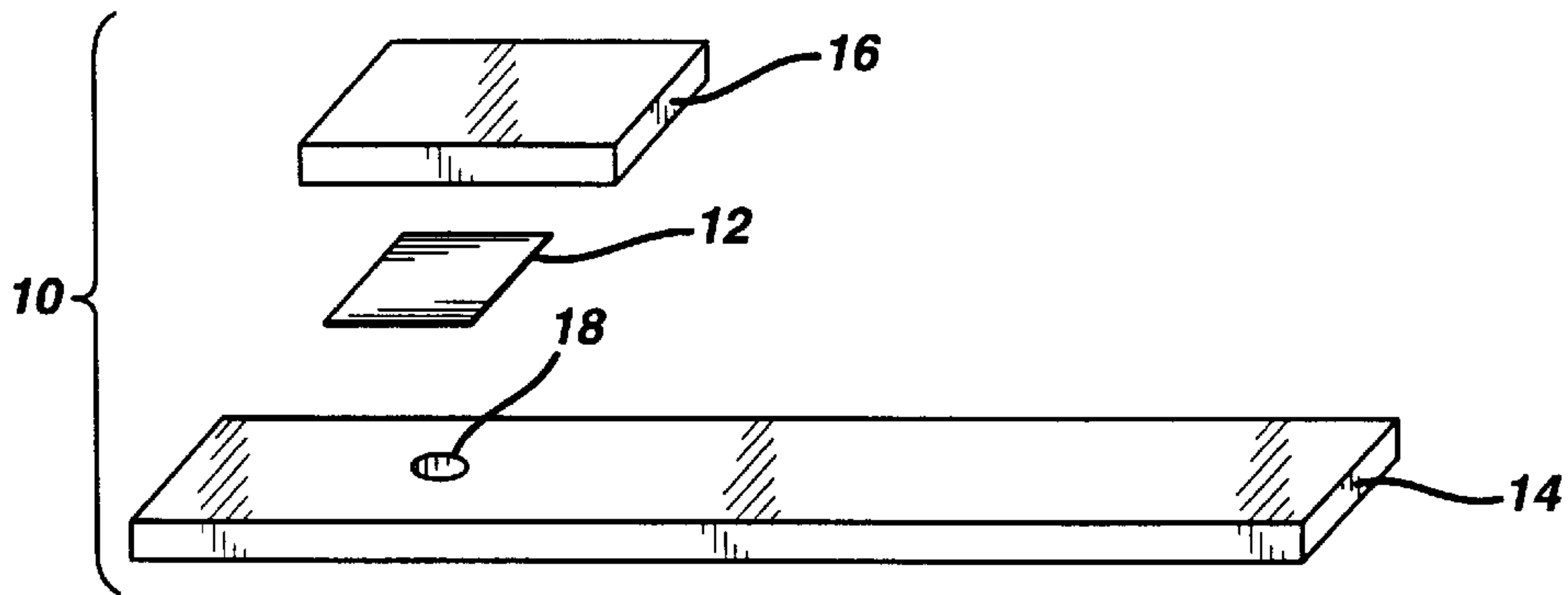

FIG. 3

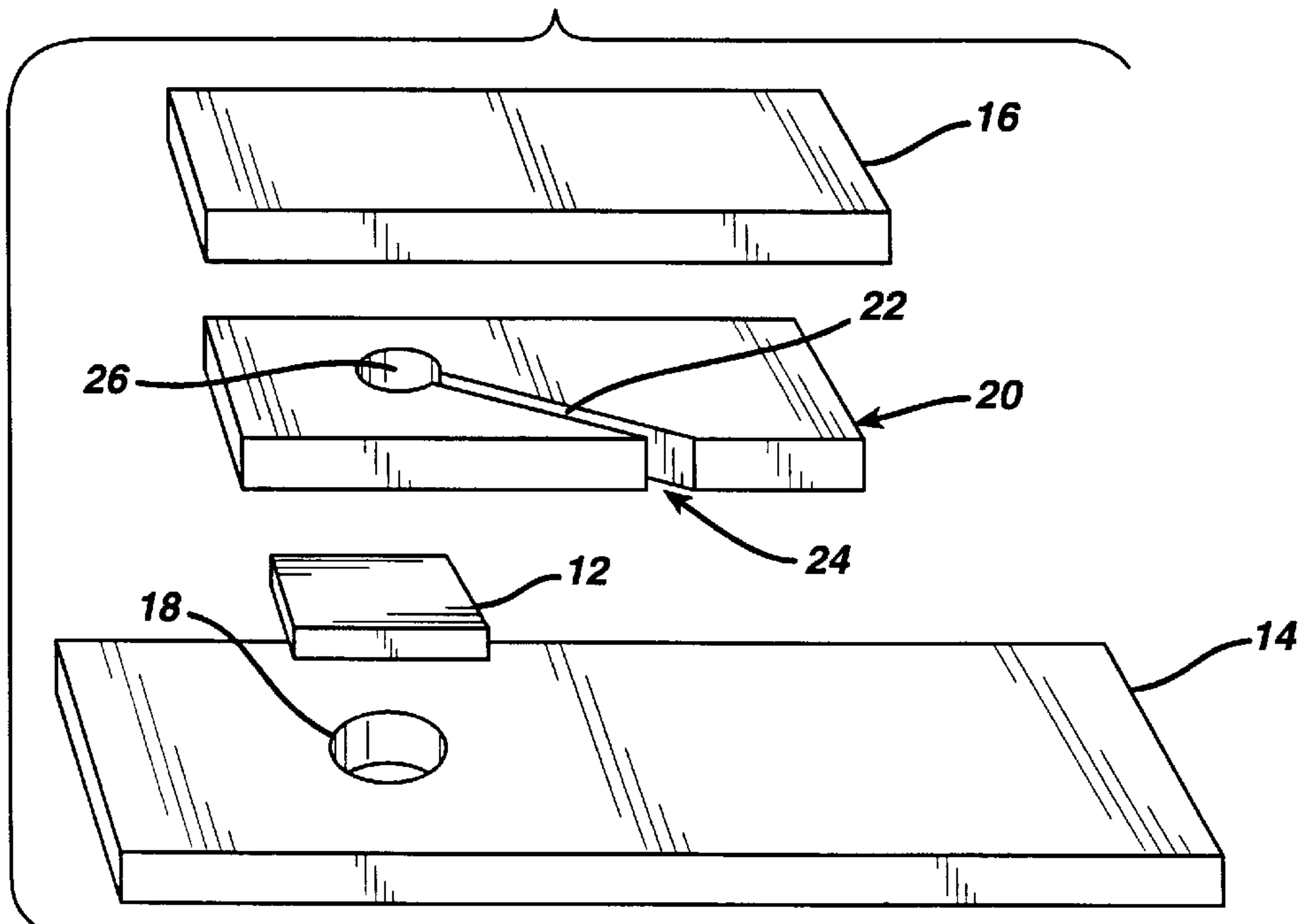

FIG. 4

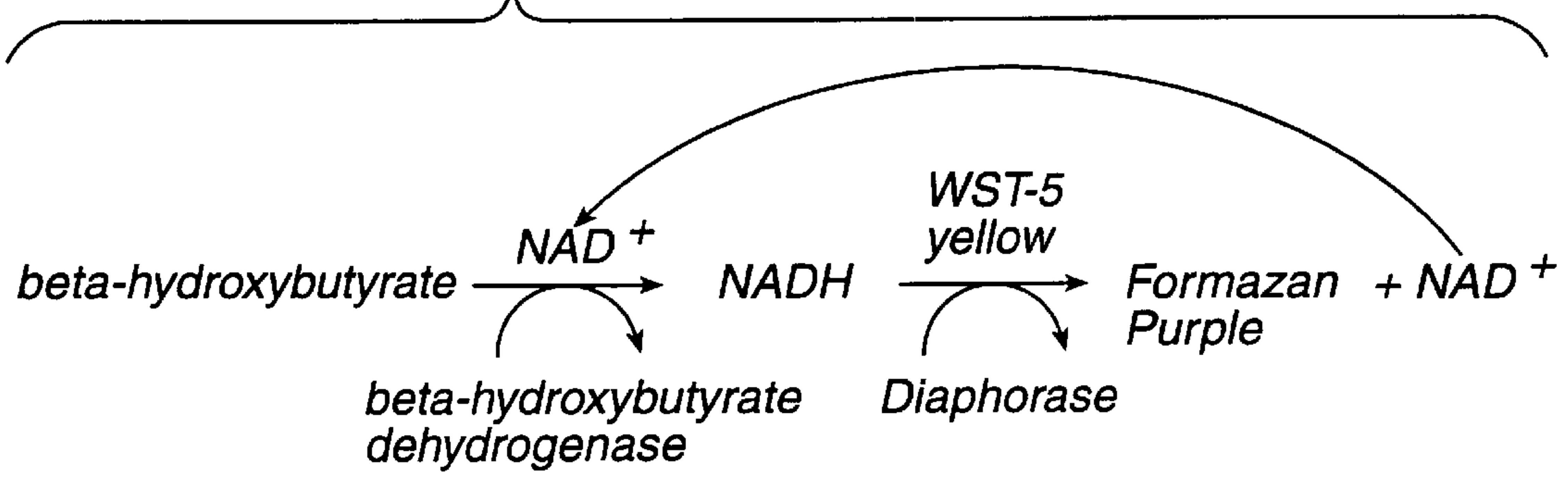
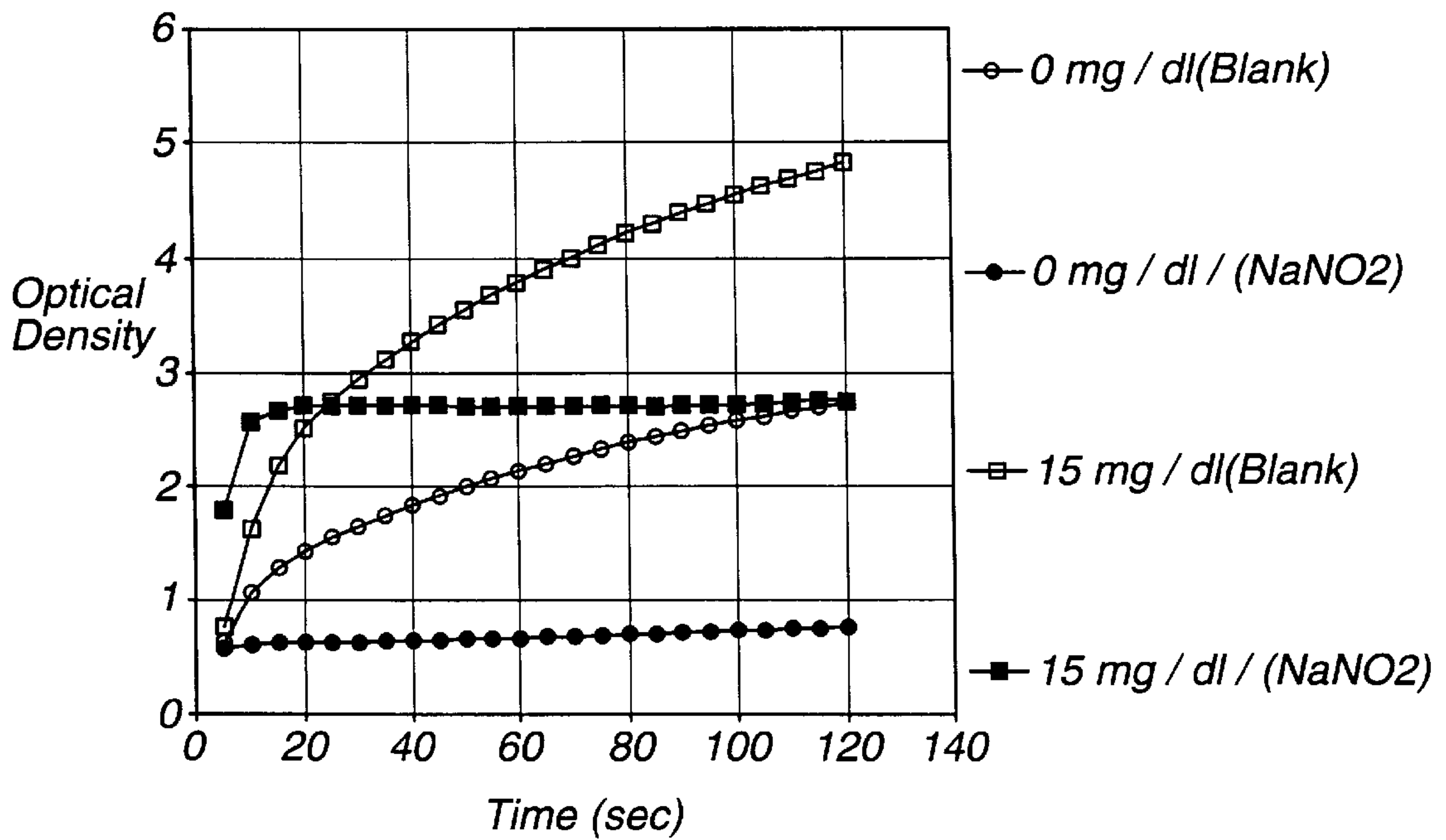

FIG. 5



DIAGNOSTICS BASED ON TETRAZOLIUM COMPOUNDS

BACKGROUND OF INVENTION

1. Field of the Invention

This invention relates to diagnostic compositions that permit the measurement of analyte concentrations in hemoglobin-containing biological fluids. The compositions are based on tetrazolium dye precursors and involve suppressing the hemoglobin-induced reduction of them.

2. Description of the Related Art

Adipose tissue is one of the most abundant forms of energy storage in the body. It releases stored fatty acids into the circulatory system to be metabolized primarily by the liver. In the process, fat is consumed and energy is released and made available to the body. Normally, little fat is consumed, the fatty acids are completely metabolized to carbon dioxide and water, and the conversion does not upset the delicate pH balance of the body. However, if insufficient amounts of carbohydrates are present in the body, due, for example, to dieting, then fat consumption and fatty acid production can increase to potentially harmful levels. In addition to dieters, insulin-dependent patients are vulnerable, because of their impaired carbohydrate metabolism. When excessive fatty acid is used to supply a body's energy demand, then large quantities of acetoacetate, acetone, and beta-hydroxybutyrate are produced. These intermediates are referred to as ketone bodies, and the condition is known as ketoacidosis.

The ketone bodies can normally be recycled into other forms by the body, provided it is not overwhelmed. Therefore, a healthy individual accumulates a negligible amount of these analytes. When a large quantity of fats is being metabolized in a relatively short period or when most of the energy is derived from fats, massive amounts of ketone bodies are produced. Excessive production of these fat metabolites can cause certain neurologic disorders, if the problem is not corrected promptly.

Ketone bodies are present in blood and, if a threshold is exceeded, are excreted via the urine. They are easily detected by a modern clinical analyzer. On average, the percentages of beta-hydroxybutyrate, acetoacetate, and acetone are 78%, 20% and 2%, respectively. Because of its relatively low concentration and high volatility, acetone is seldom measured. Instead, acetoacetate is quantitatively determined by a nitroprusside reaction and the beta-hydroxybutyrate is quantified with an enzymatic method. Acetoacetate test strips have been available for decades. They are based on a nitroprusside ion coupling reaction with aldehydes and ketones. An alkaline urine sample or a serum specimen is allowed to react with the nitroprusside for some minutes, and a purple color is developed. The intensity of the color indicates the acetoacetate concentration. However, acetone interferes with the test, resulting in higher readings. Further, as the patient recovers from a ketoacidosis episode, the acetoacetate level in urine and in blood increases, thus making the diagnosis difficult.

The beta-hydroxybutyrate test is more useful for monitoring ketone body concentrations. It is based on the oxidation of beta-hydroxybutyrate with the corresponding dehydrogenase in the presence of nicotinamide adenine dinucleotide (NAD) cofactor. (Strictly speaking, only D-beta-hydroxybutyrate is naturally present and oxidized, but we omit the "D" for brevity throughout this specification and the appended claims.) Upon the oxidation, NADH is produced, and its concentration is measured directly with a

UV spectrophotometer. Hence, the corresponding signal change in the spectrum is proportional to the analyte's concentration. Unfortunately, the excitation of NADH occurs in the UV region; thus, this mode of detection is suitable only for laboratory instruments. Another method for monitoring beta-hydroxybutyrate is by oxidizing the NADH with a tetrazolium compound.

Tetrazolium compounds have played an important role in studies of tissue metabolism. For example, this class of compounds has been used in probing anaerobic oxidation and reduction reactions in cells. Further, they are commonly used in clinical diagnostics. The compounds are typically light-colored or colorless compounds that undergo a reduction reaction, in the presence of a reducing agent, to yield a highly colored formazan. Reducing agents such as ascorbates, sulfhydryls, or variants of NADH and NADPH are capable of forming the dye.

In clinical diagnostics, these dyes have been found to be invaluable for monitoring the formation of NAD(P)H from their parent compounds, NAD(P)⁺, in anaerobic reactions. The redox reaction is rapid and is not sensitive to oxygen. The resulting dye color is very intense and has low solubility in water.

In principle, tetrazolium dye precursors can be used to measure ketone bodies and glucose in whole blood. However, the tetrazolium can be reduced non-enzymatically by hemoglobin (Fe(II)) to form a colored formazan, if the hemoglobin is not contained within the red cells of the blood. Thus, free hemoglobin causes serious interference with the measurements. In fact, due to hemolysis and the resultant abundance of free hemoglobin relative to the analyte of interest, in a typical clinical sample, the interfering signal from hemoglobin could exceed the intended signal. This is particularly true in high hematocrit samples or when the reaction is carried out at a higher temperature, where the hemoglobin oxidation reaction is faster. Since the hemolysis of red blood cells, which causes free hemoglobin to be present, cannot easily be avoided, red blood cells must be removed from samples prior to testing, if tetrazolium is to be used for the analysis.

Red blood cells can be removed from samples by filtering with membranes and filters, by trapping with chemical reagents, or by a combination of both methods. Filtration methods for separating red cells from whole blood are costly and require rather large sample volumes. An example of a blood ketone (beta-hydroxybutyrate) test that uses filtration to eliminate red cells from a whole blood sample is the KetoSite® test available from GDS Diagnostics, Elkhart, Ind. (See Tietz Textbook of Clinical Chemistry, 2nd Ed., ed. by C. Burtis et al., W. B. Saunders Co., Philadelphia, Pa., 1994, p. 974.) The "Test Card" used in that test has two filter layers, which makes the card rather costly and necessitates a large (25 μ L) blood sample. Further, the blood must not be hemolyzed.

A combination of filtration and chemical trapping is used in the Ames® Glucometer Encore™ blood glucose strip, available from Miles. That strip uses a layer of filter material and an agglutination aid (potato lectin) to eliminate interference from red cells. (See Chu et al., European Pat. Appl. 0 638 805 A2, publ. Feb. 15, 1995.)

Introducing an oxidizing agent into a system, to oxidize the hemoglobin to methemoglobin, is another way to reduce the hemoglobin interference. Although ferricyanides are known to transform hemoglobin to methemoglobin, they also destroy the desired product, NADH.

SUMMARY OF THE INVENTION

The present invention provides a reagent for measuring the concentration of an analyte in a hemoglobin-containing biological fluid. The reagent comprises:

- a) a dehydrogenase enzyme that has specificity for the analyte,
- b) nicotinamide adenine dinucleotide (NAD) or an NAD derivative,
- c) a tetrazolium dye precursor,
- d) a diaphorase enzyme or an analog thereof, and
- e) a nitrite salt.

The reagent is particularly suited for coating onto one or more substrates to form a dry reagent strip for measuring an analyte. A particularly preferred strip comprises

- a) a support layer,
- b) on the support layer, a test pad having a coating that comprises
 - i) a dehydrogenase enzyme that has specificity for the analyte,
 - ii) nicotinamide adenine dinucleotide (NAD) or an NAD derivative,
 - iii) a tetrazolium dye precursor, and
 - iv) a diaphorase enzyme or an analog thereof, and
- c) on the test pad, a bibulous top layer that is coated with a nitrite salt.

BRIEF DESCRIPTION OF THE DRAWINGS

FIG. 1 is a perspective view of a test strip of this invention.

FIG. 2 is an exploded view of another test strip of this invention.

FIG. 3 is an exploded view of yet another test strip of this invention.

FIG. 4 is a pictorial depiction of the chemistry of a ketone assay of this invention.

FIG. 5 is a graph that shows the effect of nitrite as a hemoglobin suppressor.

DETAILED DESCRIPTION OF THE INVENTION

The present invention provides a reagent for measuring analyte concentration in hemoglobin-containing biological fluids (such as whole blood), by producing a concentration of NADH that is a measure of the analyte concentration. Inclusion of nitrite in the reagent overcomes the interference of hemoglobin with the measurement of the NADH concentration. It is particularly useful for, but not limited to, measurement of ketone bodies.

FIG. 1 depicts a typical test strip 10 of the invention, which consists of a test pad 12 affixed onto a support 14. The support may be a plastic—e.g., polystyrene, nylon, or polyester—or metallic sheet or any other suitable material known in the art. The test pad is coated with a reagent that reacts with the analyte to cause a color change. The test pad preferably comprises a bibulous material, such as filter paper or polymer membrane. However, since the reaction doesn't require oxygen, the test pad may be a non-bibulous material, such as plastic film. The reagent includes an enzyme that is specific to the analyte, a hydride transfer agent, a tetrazolium dye precursor, a suitable enzyme cofactor, and a hemoglobin suppressor. Optionally, a buffer and stabilizer are included for greater stability.

As shown in FIG. 2, the test strip can also be a multilayer construction, with top layer 16 overlaying test pad 12. In that construction, the reagent may be divided between the two layers. For example, the hemoglobin suppressor may be coated onto optional top layer 16 and the balance of the reagent coated onto test pad 12. Preferably, top layer 16 is

bibulous and serves as a spreading layer and as an absorbent layer to absorb excess sample. Sample is applied to top layer 16, and it passes through to test pad 12. The analyte concentration is determined by measuring the color change through support layer 14 or, if layer 14 is not transparent where it adjoins the reaction area, through optional window or through-hole 18.

In the alternative embodiment shown in FIG. 3, spacer 20 separates top layer 16 and test pad 12. Spacer 20 is preferably a non-bibulous plastic film having an adhesive coating (not shown) on both faces. Channel 22 in spacer 20 provides a capillary path for sample to flow from opening 24 to measurement area 26. The flow depends on air venting between a surface of test pad 12 and an adjoining layer or, alternatively, through optional vent 18. The color change in measurement area 26 is monitored through optional vent/window 18. Reagent may all be on test pad 12 or, alternatively, may be divided among the test pad and one or both of non-bibulous layers 14 and 16. Thus a first part of the reagent may be on the test pad and a second part of the reagent may be on one or both of the non-bibulous layers. When we refer to reagent as being a "coating" or "on" a layer, we intend to include the possibility that reagent will be absorbed into the layer, particularly if it is bibulous.

The enzymes that are suitable for assays with this invention and the corresponding analytes are: alcohol dehydrogenase for alcohol, formaldehyde dehydrogenase for formaldehyde, glucose dehydrogenase for glucose, glucose-6-phosphate dehydrogenase for glucose-6-phosphate, glutamate dehydrogenase for glutamic acid, glycerol dehydrogenase for glycerol, beta-hydroxybutyrate dehydrogenase for beta-hydroxybutyrate, hydroxysteroid dehydrogenase for steroid, L-lactate dehydrogenase for L-lactate, leucine dehydrogenase for leucine, malate dehydrogenase for malic acid, and pyruvate dehydrogenase for pyruvic acid.

A suitable enzyme cofactor is needed to activate the enzyme. Depending on the enzyme, these cofactors may be used: beta-nicotinamide adenine dinucleotide (beta-NAD), beta-nicotinamide adenine dinucleotide phosphate (beta-NADP), thionicotinamide adenine dinucleotide, thionicotinamide adenine dinucleotide phosphate, nicotinamide 1,N6-etheno adenine dinucleotide, and nicotinamide 1,N6-etheno adenine dinucleotide phosphate. In the presence of the enzyme, the analyte reduces the cofactor.

The next step in the dye-forming process is hydride abstraction from the reduced cofactor. It can be accomplished either by a diaphorase, such as lipoic dehydrogenase, ferredoxin-NADP reductase, lipoamide dehydrogenase, or by a synthetic analog, such as phenazine methosulfate (PMS) or Meldola Blue. Reaction kinetics and stability are the primary factors for selecting a hydride transfer agent or "abstractor". For example, PMS is the universal hydride abstractor, because it has relatively fast reaction kinetics with most of the tetrazolium compounds listed below. It is, however, more sensitive to light than enzyme-based hydride abstractors. Diaphorase is more stable and, for that reason, is preferred.

The captured hydride is transferred to a tetrazolium compound (dye precursor) to form a colored formazan. Tetrazolium compounds that are most suitable for this device are: 2-(2'-benzothiazolyl)-5-styryl-3-(4'-phthalhydrazidyl) tetrazolium (BSPT), 2-benzothiazolyl-(2)-3,5-diphenyl tetrazolium (BTDP), 2,3-di(4-nitrophenyl) tetrazolium (DNP), 2,5-diphenyl-3-(4-styrylphenyl) tetrazolium (DPSP), distyryl nitroblue tetrazolium (DS-NBT), 3,3'-[3,3'-dimethoxy-(1,1'-biphenyl)-4,4'-diyl]-bis[2-(4-

nitrophenyl)-5-phenyl(-2H tetrazolium (NBT), 3-(4,5-dimethyl-2-thiazolyl)-2,5-diphenyl-2H tetrazolium (MTT), 2-phenyl-3-(4-carboxyphenyl)-5-methyl tetrazolium (PCPM), tetrazolium blue (TB), thiocarbamyl nitroblue tetrazolium (TCNBT), tetranitroblue tetrazolium (TNBT), tetrazolium violet, (TV), 2-benzothiazothiazolyl-3-(4-carboxy-2-methoxyphenyl)-5-[4-(2-sulfoethylcarbamoyl)phenyl]-2H-tetrazolium (WST-4), and 2,2'-dibenzothiazolyl-5,5'-bis [4-di(2-sulfoethyl)carbamoylphenyl]-3,3'-(3,3'-dimethoxy-4,4'-biphenylene)ditetrazolium, disodium salt (WST-5). WST-5 is preferred, because it readily dissolves in an aqueous medium, which is most compatible with biological samples. Further, the resulting formazan compound exhibits strong spectral absorption at the purple-blue region, thus reducing the need for correcting the background signal from hemoglobin.

Finally, a hemoglobin suppressor is present in the reagent to curtail the undesirable dye-forming reaction between hemoglobin and the tetrazolium compound. The role of the hemoglobin suppressor is to oxidize the hemoglobin to methemoglobin, which does not react with the tetrazolium. Surprisingly, nitrite salts, such as sodium nitrite, potassium nitrite, and their derivatives, are very effective in suppressing the hemoglobin, while not destroying the NADH. The nitrites are effective, as well, at elevated temperature and with high hematocrit samples. Sodium nitrite is preferred, because it has high aqueous solubility, is not toxic, and is relatively inexpensive.

Although the reagent of this invention can be used in a wet chemical mode, such as in a cuvette, in a preferred embodiment, the invention is a dry strip for assaying beta-hydroxybutyrate in whole blood. It consists of a membrane test pad, preferably of nylon, that is placed between a support and a top layer. The support is preferably of polyester sheet. The top layer can be any bibulous material known in the art. A preferred material is a porous polyethylene treated with sodium methyl oleoyl taurate, available from the Porex Corp. of Fairburn, Ga. We refer to this material as "Porex". The test pad contains a reagent comprising beta-hydroxybutyrate dehydrogenase, NAD, diaphorase, and WST-5 (Table 1, below). The Porex top layer contains a nitrite reagent (Table 2).

In operation, a user applies a drop of whole blood to the upper surface of the Porex top layer. As the whole blood or lysed blood comes into contact with the Porex, the sodium nitrite is reconstituted and reacts with the available free hemoglobin, thus rendering the hemoglobin harmless to the assay. The resulting, substantially hemoglobin-free sample is transferred to the test pad below, via capillary or gravitational force. On the test pad, the sample initiates the cascade reaction depicted in FIG. 4 to yield a colored dye, whose concentration is proportional to the beta-hydroxybutyrate in the sample and can be determined directly with a photometer.

FIG. 5 depicts the effect of nitrite on the color-forming reaction in this system, using blood samples containing 0 and 15 mg/dL. In the absence of nitrite, hemoglobin reduces the tetrazolium to form a continually increasing dye concentration, with a corresponding increase in optical density. Nitrite, by removing the hemoglobin (by oxidation), limits the color formation to that which results solely from the ketone bodies (i.e., beta-hydroxybutyrate) in the sample.

The following example demonstrates a preferred embodiment of the present invention, in which the analyte is beta-hydroxybutyrate and the enzyme is beta-hydroxybutyrate dehydrogenase. The composition can readily be modified for application to other analyte-enzyme combinations listed earlier. (See, for example, *Tietz Textbook of Clinical Chemistry*, 2nd Ed., ed. by C. Burtis et al., W. B.

Saunders Co., Philadelphia, Pa., 1994, pp 976-978 and 1174-1175.) The Example is not intended to be in any way limiting.

EXAMPLE 1

A 0.8 μ m nylon membrane obtained from Cuno (Meriden, Conn., USA) was dipped into the reagent of Table 1, until saturated. The excess reagent was scraped off gently with a glass rod. The resulting membrane was hung to dry in a 56° C. oven for 10 minutes. Porex (0.6 mm thick) was soaked in the nitrite solution of Table 2 and then hung to dry in a 100° C. oven for ten hours. Finally, the membrane was laminated between a polyester stock (0.4 mm Melenex® polyester from ICI America, Wilmington, Del.) and the nitrite-impregnated Porex.

TABLE 1

Reagent for the Test Pad	
Components	Quantity
Water	100ml
Tris(hydroxymethyl)Aminomethane (MW 121, Sigma, St. Louis, MO, USA) (Adjust pH to 8.5 by adding 6M HCl)	1.2gm
Sodium Chloride (MW 56.44, Sigma, St. Louis, MO, USA)	560mg
Magnesium Chloride (MW 203, Sigma, St. Louis, MO, USA)	2.5gm
PSSA, polystyrenesulfonic acid, sodium salt (MW 70,000, Polysciences, Inc., Warrington, PA, USA)	3gm
Crotein (Croda Inc. Parsippany, NJ, USA)	3gm
Oxamic acid, sodium salt (MW 111.03, Aldrich Chemicals, Milwaukee, WI, USA)	250mg
Tetronic 1307 (BASF Corporation, Mount Olive, New Jersey, USA)	2gm
Sucrose (MW 342.30, Aldrich Chemicals, Milwaukee, WI, USA)	5gm
NAD (MW 663.4, N-7004, Sigma, St. Louis, MO, USA)	450mg
D-3-hydroxybutyrate dehydrogenase (Origin: Pseudomonas sp., HBD-301, 125 U/mg, Toyobo, Japan)	50,000U
Diaphorase (Origin: <i>B. Stearothermophilus</i> , New, 1033 U/mg, Toyobo, Japan)	340890U
WST-5 (MW 1331.37, Dojindo, Japan)	1.8gm

TABLE 2

Nitrite Reagent	
Components	Quantity
10 mM Phosphate Buffer Saline, pH 7.4, (P-3813, Sigma, St. Louis, MO, USA)	70ml
Ethanol	30ml
Sodium Nitrite (MW 69, Aldrich Chemicals, Milwaukee, WI, USA)	5gm
Polyvinylpyrrolidone (MW 40,000, Sigma, St. Louis, MO, USA)	200mg
Oxamic acid, sodium salt (MW 111.03, Aldrich Chemicals, Milwaukee, WI, USA)	500mg

We claim:

1. A reagent for measuring a concentration of an analyte in a hemoglobin-containing biological fluid, comprising
 - a) a dehydrogenase enzyme that has specificity for the analyte,
 - b) nicotinamide adenine dinucleotide (NAD) or an NAD derivative,
 - c) a tetrazolium dye precursor,
 - d) a diaphorase enzyme or an analog thereof, and
 - e) a nitrite salt.
2. The reagent of claim 1 in which the analyte is beta-hydroxybutyrate and the enzyme is beta-hydroxybutyrate dehydrogenase.

7

3. A dry reagent strip for determining the presence and amount of an analyte in a hemoglobin-containing biological fluid comprising a support layer on which is a test pad having a coating of the reagent of claim 1.

4. The strip of claim 3 further comprising a bibulous top layer overlaying the test pad.

5. A dry reagent strip for determining the presence and amount of an analyte in a hemoglobin-containing biological fluid comprising a support layer on which is a test pad and a top layer overlaying the test pad in which a first part of the reagent of claim 1 is on the test pad and a second part of the reagent is on the support and/or top layer.

6. The strip of claim 5 in which the top layer is bibulous.

7. The strip of claim 5 further comprising a spacer and channel between the top layer and test pad to provide a capillary path between the top layer and pad.

8. The strip of claim 5 in which the analyte is beta-hydroxybutyrate and the enzyme is beta-hydroxybutyrate dehydrogenase.

9. The strip of claim 5 in which the analyte is glucose and the enzyme is glucose dehydrogenase.

10. The strip of claim 5 in which the analyte is glucose-6-phosphate and the enzyme is glucose-6-phosphate dehydrogenase.

11. The strip of claim 5 in which the analyte is alcohol and the enzyme is alcohol dehydrogenase.

8

12. The strip of claim 5 in which the analyte is L-lactate and the enzyme is L-lactate dehydrogenase.

13. The strip of claim 5 in which the tetrazolium dye precursor is 2,2'-dibenzothiazolyl-5,5'-bis[4-di(2-sulfoethyl) carbamoylphenyl]-3,3'-(3,3'-dimethoxy- 4,4'-biphenylene) ditetrazolium, disodium salt (WST-5).

14. A dry reagent test strip for determining the presence and amount of an analyte in a hemoglobin-containing biological fluid, comprising

a) a support layer,

b) on the support layer, a test pad having a coating that comprises

i) a dehydrogenase enzyme that has specificity for the analyte,

ii) nicotinamide adenine dinucleotide (NAD) or an NAD derivative,

iii) a tetrazolium dye precursor, and

iv) a diaphorase enzyme or an analog thereof, and

c) on the test pad, a bibulous top layer that is coated with a nitrite salt.

* * * * *