



US005865017A

United States Patent [19]

[11] Patent Number: **5,865,017**

Short

[45] Date of Patent: ***Feb. 2, 1999**

[54] **GANG MOWER**

[76] Inventor: **Douglas Short**, 12210 Leo Rd., Fort Wayne, Ind. 46825

[*] Notice: The term of this patent shall not extend beyond the expiration date of Pat. No. 5,497,603.

[21] Appl. No.: **860,682**

[22] PCT Filed: **Jan. 11, 1996**

[86] PCT No.: **PCT/US96/00191**

§ 371 Date: **Jun. 10, 1997**

§ 102(e) Date: **Jun. 10, 1997**

[87] PCT Pub. No.: **WO96/21344**

PCT Pub. Date: **Jul. 18, 1996**

- 1,725,375 8/1929 Seeley .
- 1,902,928 3/1933 Worthington .
- 2,177,189 10/1939 Roseman .
- 2,830,421 4/1958 Blue et al. .
- 3,058,280 10/1962 Lewis .
- 3,650,096 3/1972 Caldwell .
- 3,808,778 5/1974 Hoffmeyer et al. .
- 4,021,996 5/1977 Bartlett et al. .
- 4,287,706 9/1981 Tobin, Jr. .
- 4,330,981 5/1982 Hall et al. .
- 5,343,680 9/1994 Reichen et al. .

FOREIGN PATENT DOCUMENTS

- 2842739 4/1980 Germany .
- 9312843.6 2/1994 Germany .
- 714138 8/1954 United Kingdom .

Related U.S. Application Data

[63] Continuation of Ser. No. 370,664, Jan. 10, 1995, Pat. No. 5,497,603.

[51] Int. Cl.⁶ **A01D 75/30**

[52] U.S. Cl. **56/7; 56/249**

[58] Field of Search 56/6, 7, 249, 294, 56/15.4, 15.5, 15.6

References Cited

U.S. PATENT DOCUMENTS

1,663,900 3/1928 Braun .

Primary Examiner—Heather Shackelford
Attorney, Agent, or Firm—Michael B. McNeil

[57] ABSTRACT

A gang mower for garden tractors includes a frame, a hitch and either three, five or seven reel-type mower units attached to the frame. The frame is attached below the forward wheel axis of each mower unit. In action, the frame leverages the forward drive wheels downward to turn the mower blades when the frame is pulled forward by a garden tractor.

20 Claims, 3 Drawing Sheets

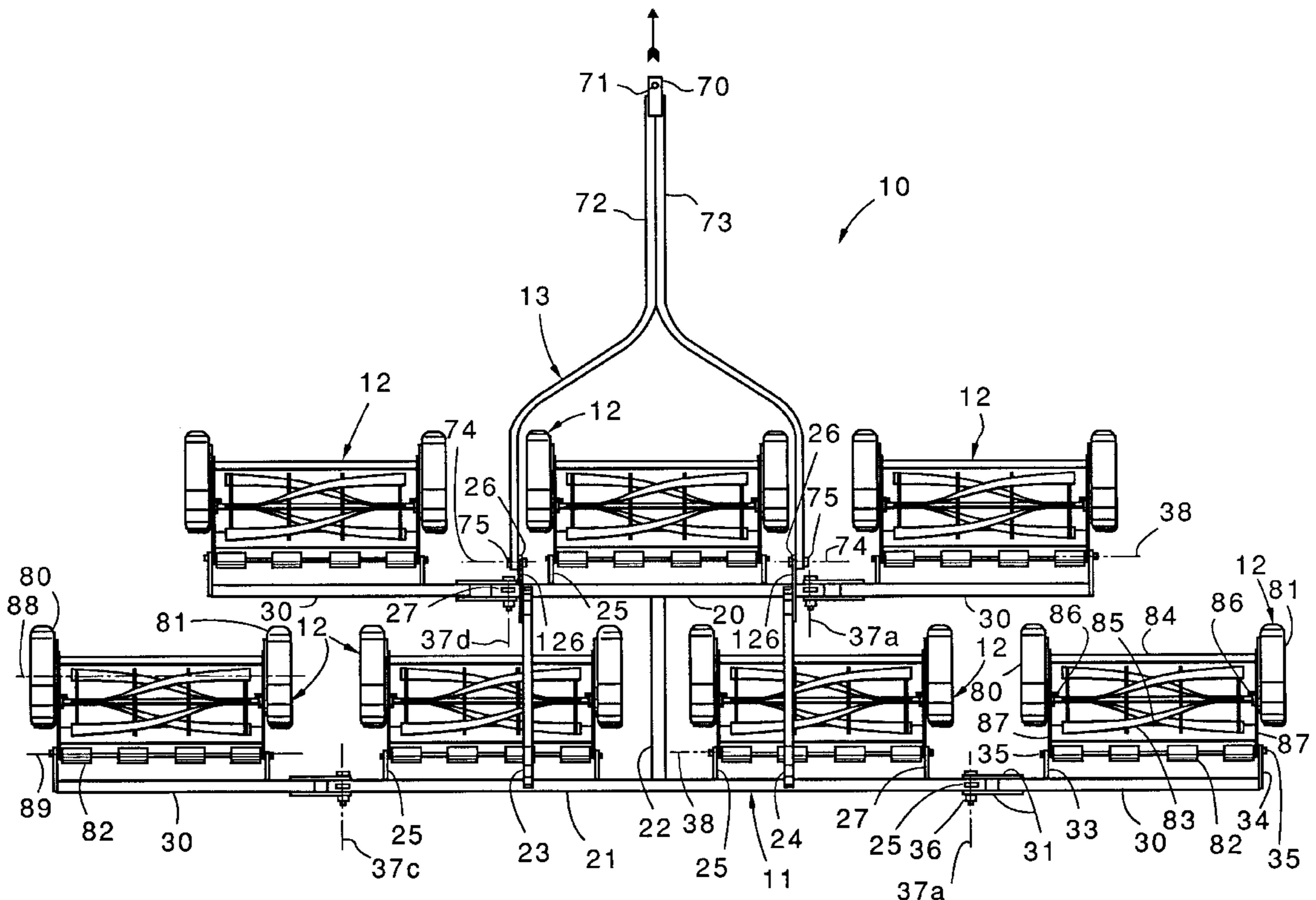

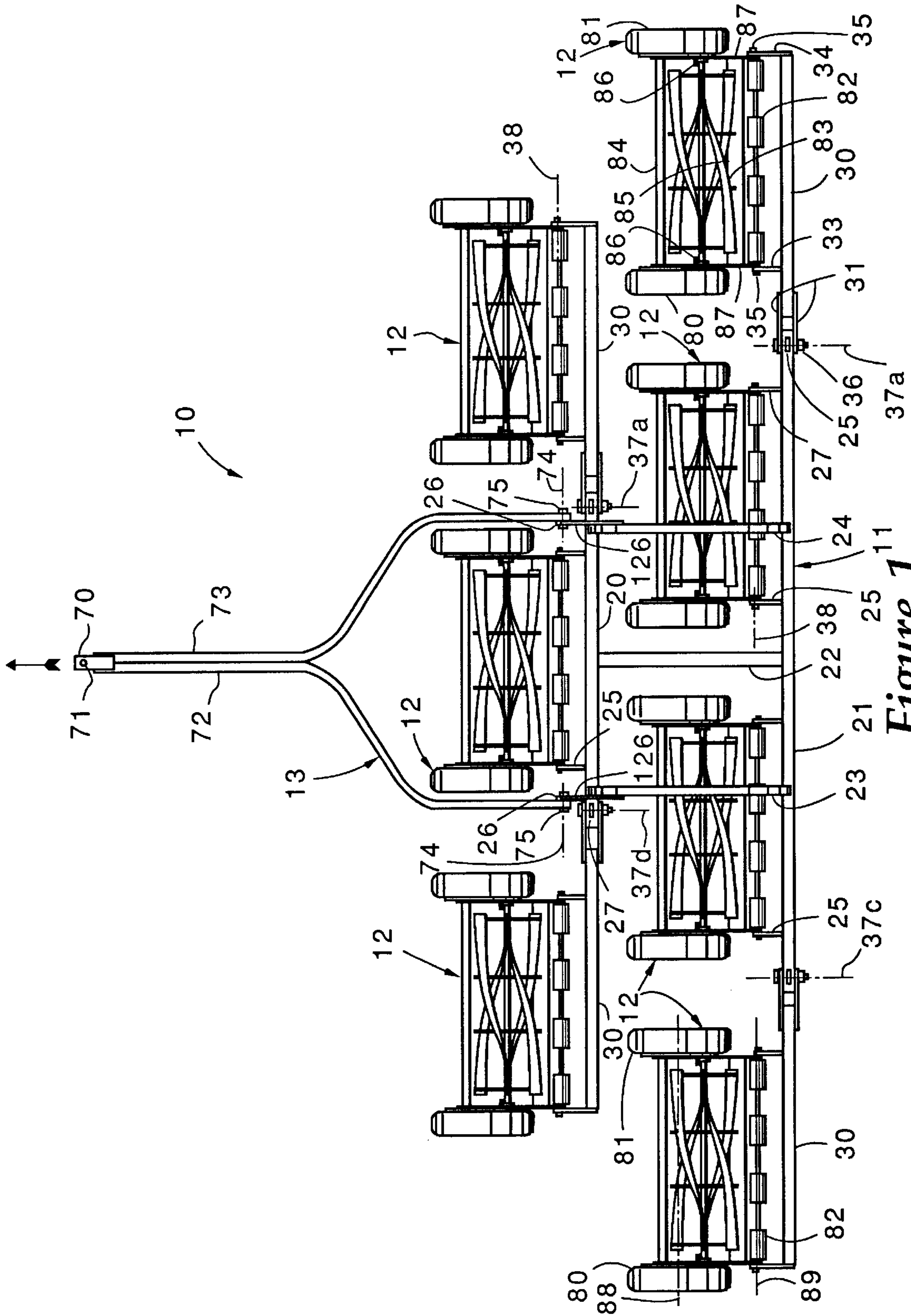
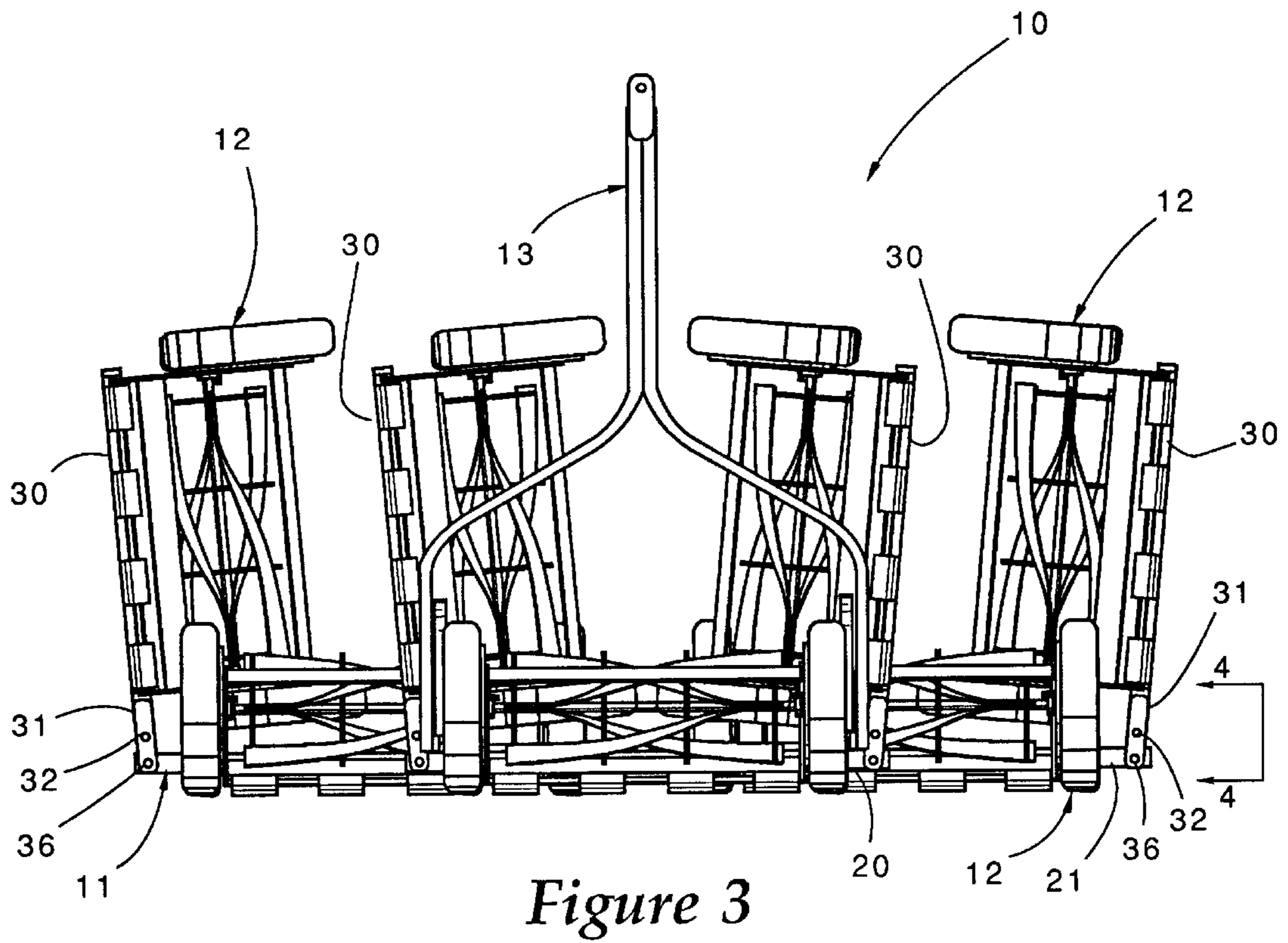
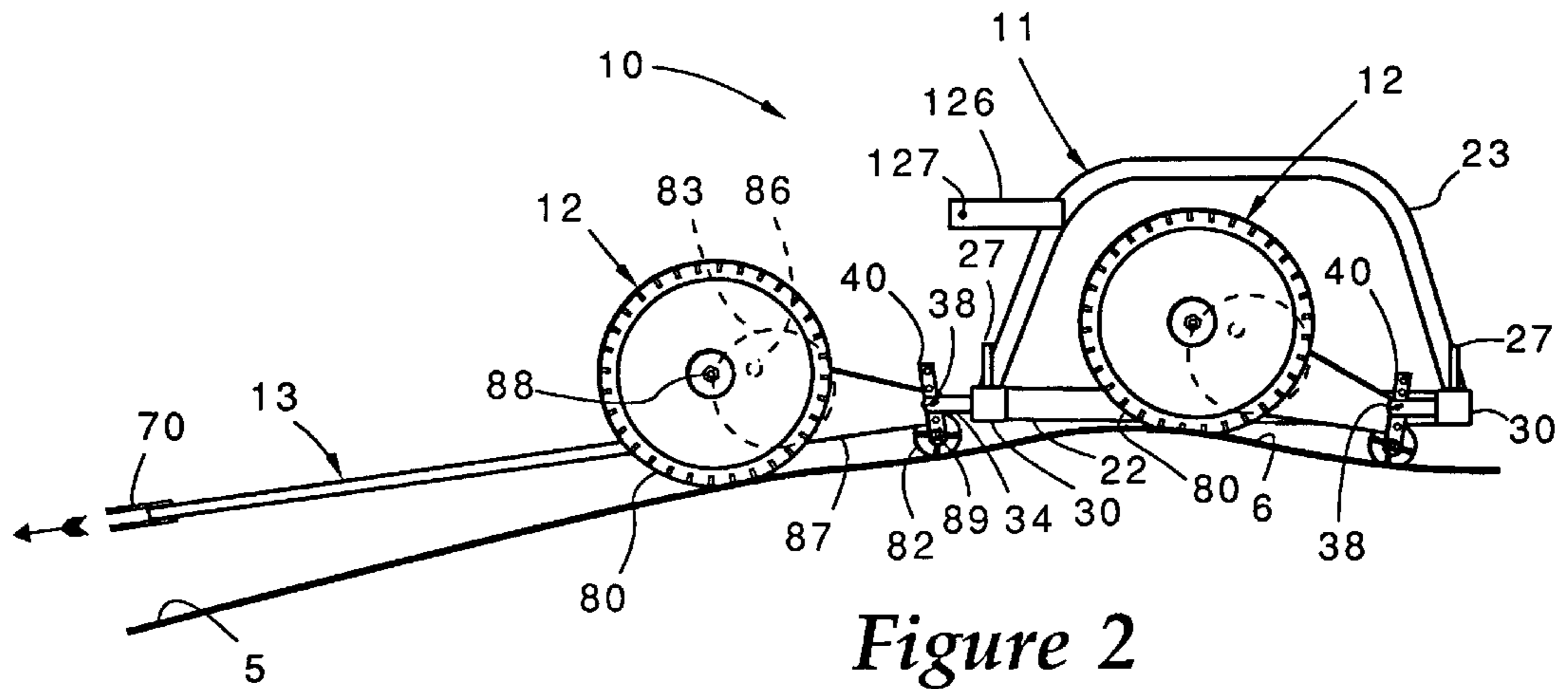
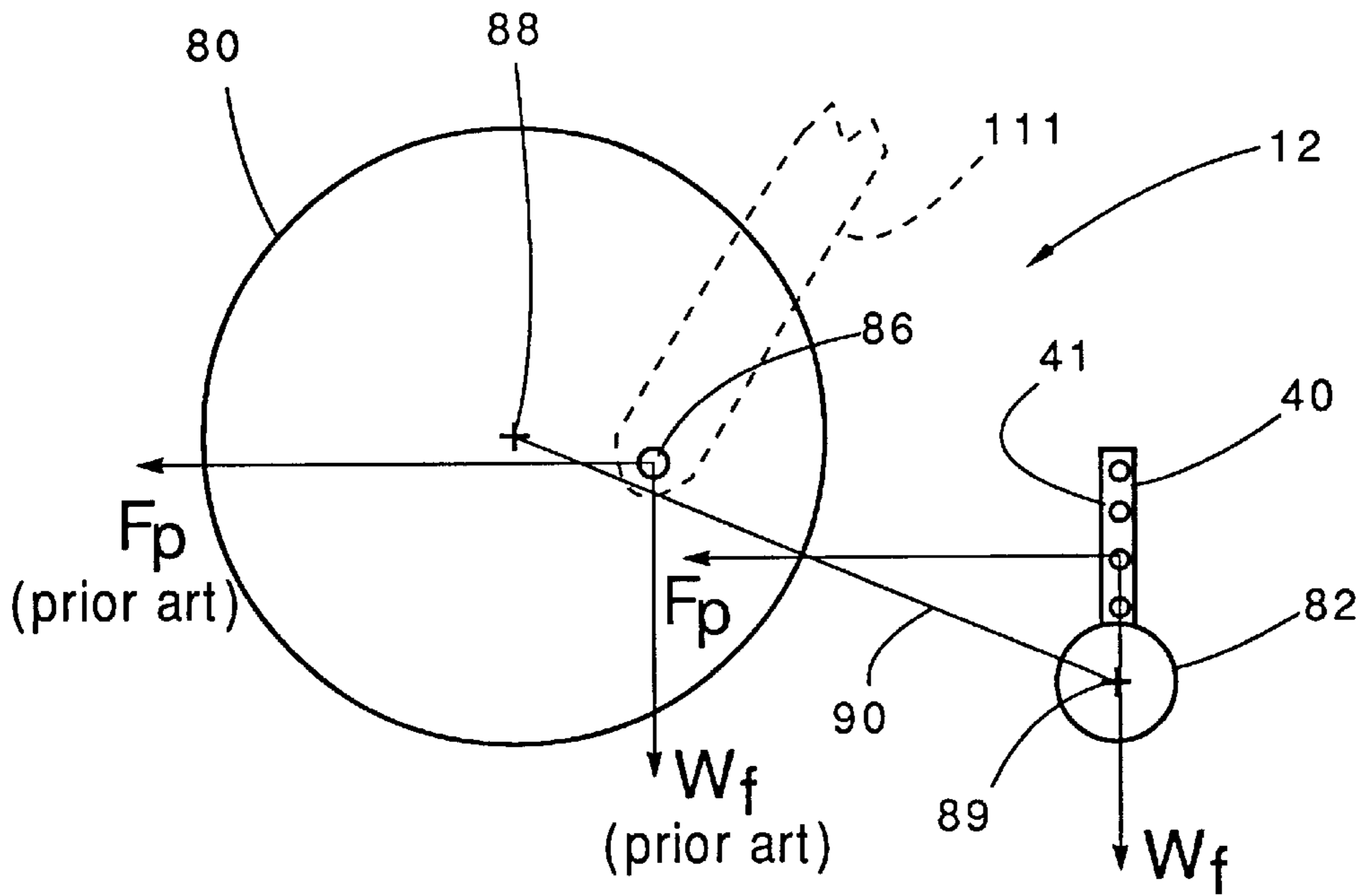
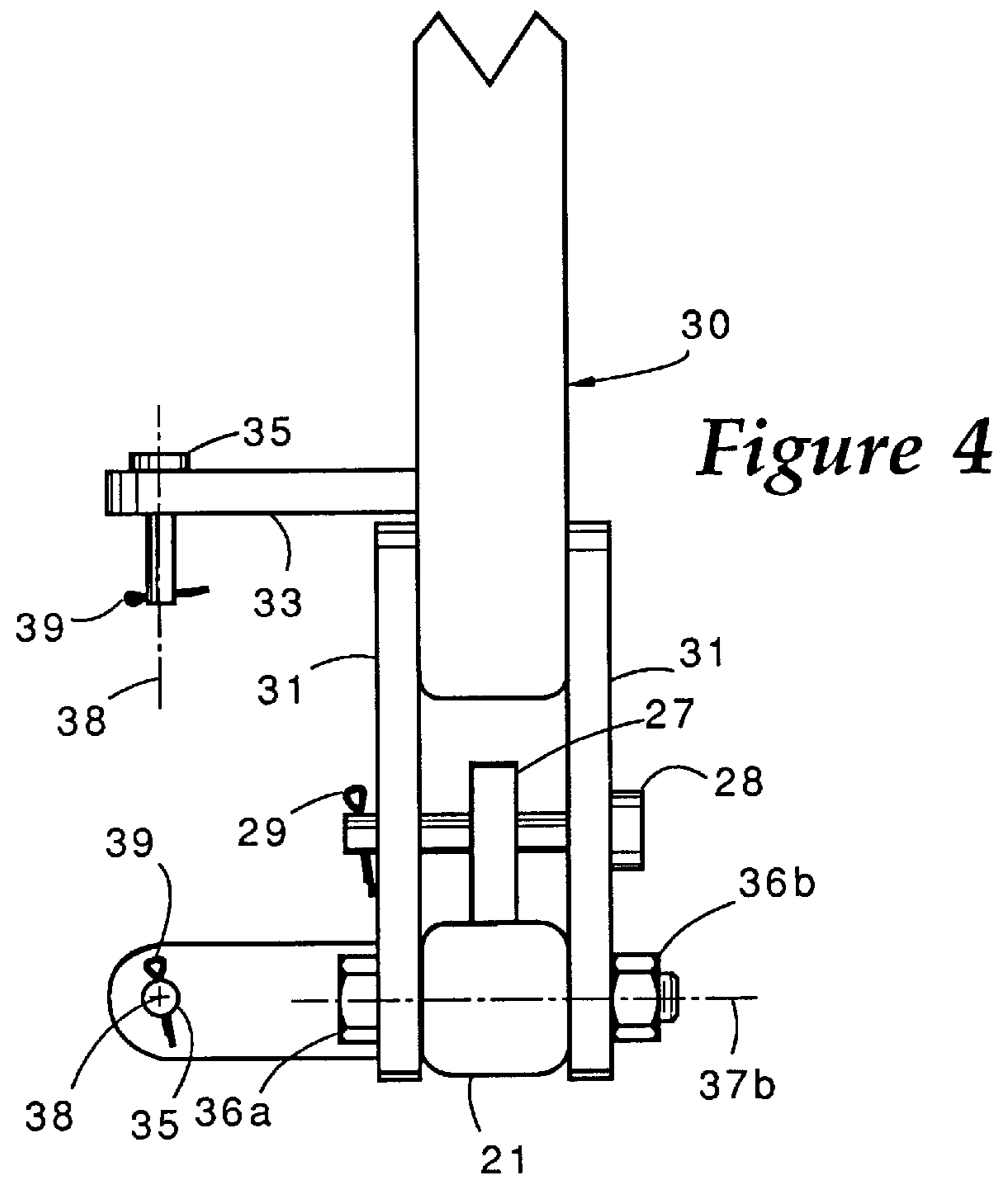

Figure 1





GANG MOWER**RELATION TO OTHER PATENT APPLICATION**

This application is a continuation of U.S. patent application Ser. No. 08/370,664, filed Jan. 10, 1995, and entitled Gang Mower, now U.S. Pat. No. 5,497,603.

FIELD OF THE INVENTION

The present invention relates generally to reel-type gang mowers, and in particular to gang mowers for use with home garden tractors or draft animals.

BACKGROUND OF THE INVENTION

Reel-type gang mowers have long been known in the art, and are most often identified with golf courses and other wide open areas requiring an attractive contoured cut. Gang mowers are often recognized for their ability to mow a given area in a significantly shorter amount of time than that possible with conventional power mowers. This is due in part to the relatively large swath (8 feet or more) possible with gang mowers, whereas power mowers typically cut a swath of four feet or less with each pass. Gang mowers can also usually be pulled faster than a comparable power mower without sacrificing on the quality of the cut. Therefore, not only are gang mowers well known for their ability to make an attractive contoured cut, they are also known to be significantly faster than the largest counterpart power mowers, provided one has a tractor with sufficient power to pull the gang mower.

Most prior art gang mowers are relatively heavy and normally require a relatively powerful tractor to pull the gang mower. In other words, home garden tractors have typically not been sufficiently powerful to pull most commercially available gang mowers. Thus, most if not all homeowners with relatively large estates (several acres or more) must choose between one of a variety of home garden tractors with power mower attachments for use in mowing their large lawns. These tractor power mowers typically have a rotating blade on the order of three feet in diameter but rarely, if ever, exceeding four feet in diameter. This is because larger decks, 40 inches or larger, will often scalp the ground on one side while being too far off the ground on the other when the mower encounters even moderate contouring. Thus, the homeowner that desires an attractive cut must necessarily choose a smaller sized deck and spend multiple hours each week riding his or her lawn mower back and forth around their yard. Reel-type gang mowers have not been a realistic alternative to these homeowners because the gang mowers of the prior art typically require a large storage area, and relatively larger tractors, which are prohibitively expensive and also require their own added storage space.

One of the reasons that gang mowers of the prior art are relatively heavy is because the individual mower units are typically attached to the gang mower frame in a way that requires a relatively large downward force in order to maintain the individual mower units in proper contact with the ground at all times. In particular, prior art gang mower frames are typically attached above and forward from the individual mower units, with the consequence being that the frames (and mower units) must be relatively heavy in order to maintain both the drive wheels and the trailing rollers of the individual mower units in contact with the ground. Examples of such gang mowers include but are not limited to the gang mowers shown in U.S. Pat. No. 1,663,900 to Braun, U.S. Pat. No. 1,902,928 to Worthington and U.S. Pat. No. 2,830,421 to Blue et al.

A more recent gang mower assembly illustrated in U.S. Pat. No. 4,287,706 to Tobin Jr., overcomes some of the weight problems of the prior art to produce a gang mower suitable for use with home garden tractors. Tobin Jr. accomplishes this by making a gang mower frame that attaches to the handle studs of the individual reel-type mower units. Thus, in theory the frame pushes forward and downward on the handle studs of the individual mower units when the frame is pulled forward by a garden tractor. In other words, the individual mowers units are pushed forward when the frame is pulled. While this concept apparently permitted a lower weight frame suitable for use with garden tractors, a number of problems have persisted in the Tobin Jr. gang mower design. Not the least of which is the recognition by Tobin that a spring is often required in order to apply a moment about the handle studs of the mower units in order to help maintain the rollers of the individual mowers on the ground at all times. It is well known that it is absolutely critical for the proper functioning of a reel-type mower that both the drive wheels and the trailing roller always remain in contact with the ground. Tobin Jr., also suffers from a number of other problems that have persisted in the art, including the inability to back up when the gang mower is attached to a tractor, the inability to store the gang mower in a relatively small space, the inability of the gang mower to properly follow lawn contours, and other problems.

In view of the prior art, what is needed is a reel-type gang mower that is low weight, capable of being stored in a relatively small space, is suitable for use with home garden tractors and overcomes many of the practicality problems encountered with the various gang mowers of the prior art.

SUMMARY OF THE INVENTION

In responding to this need, the present invention provides a gang mower for garden tractors comprising a frame, a hitch attached to and extending forward from the frame, and a plurality of reel-type mowers attached to the frame. Each of the reel-type mowers has a pair of forward wheels and a rear roller. The forward wheels are rotatable about a forward axis, and the rear roller is rotatable about a rear axis that is substantially parallel to the forward axis. The frame is attached to each of the reel-type mowers at a position higher than the rear axis, lower than the forward axis and a sufficient distance away from forward axis that a majority of the frame's weight is supported by the rollers of the reel-type mowers instead of by the forward wheels of the reel-type mower units. When in action, the frame pushes the reel-type mower forward when the frame itself is pulled forward by the hitch.

The present invention can include a number of enhancements including the possibility of a frame that is substantially rigid with respect to a vertical axis such that the relative positioning of the reel-type mowers in a plane perpendicular to the vertical axis remain substantially constant regardless whether the gang mower is being pulled forward around curves or pushed backward. Also, the reel-type mowers can be attached to the frame at pivot points that permit the individual mower units to pivot with respect to the frame about horizontal axes through the pivot points. In another enhancement the frame can include a plurality of outer portions that are attached to the central frame at pivot points that permit the outer mower units to pivot about horizontal axes. Both pivoting enhancements allow the mower to follow lawn contours and produce a more attractive cut. Furthermore, the outer frame units and the hitch can be made to pivot to a stowed position so that the gang mower can be stored in a relatively small space. Other aspects and

potential enhancements of the invention will be more thoroughly identified and discussed in the detailed description of the invention.

One object of the present invention is to provide a gang mower that will permit a homeowner to mow their lawn in a fraction of the amount of time possible with counterpart power mowers.

Another object of the present invention is to provide a gang mower for garden tractors that overcomes the storage and backing up problems of the prior art.

Still another object of the present invention is to provide a relatively light-weight gang mower.

Still another object of the present invention is to provide homeowners with a professional looking contoured cut to their lawns at a fraction of the price possible with counterpart riding power mowers.

Another object of the present invention is to provide an improved gang mower for garden tractors.

BRIEF DESCRIPTION OF THE DRAWINGS

FIG. 1 is a top view of a gang mower for garden tractors according to the present invention.

FIG. 2 is a side elevational view of a gang mower for garden tractors according to the present invention.

FIG. 3 is a front elevational view of a gang mower for garden tractors according to the present invention in its stowed configuration.

FIG. 4 is an enlarged side elevational view of a portion of a gang mower frame according to one aspect of the present invention.

FIG. 5 is a side diagrammatic illustration of a reel-type mower unit contrasting the force distribution of the frame of the present invention versus that of the prior art.

DETAILED DESCRIPTION OF THE PREFERRED EMBODIMENT

Referring now to FIG. 1, a gang mower for garden tractors 10 according to the present invention includes a frame 11, a hitch 13 and seven individual reel-type mower units 12. Frame 11 includes a central portion made up of a forward sub-frame 20 and a rearward sub-frame 21 arranged behind and substantially parallel to the forward sub-frame. Sub-frames 20 and 21 are interconnected by a horizontal stiffener 22 and a pair of arched stiffeners 23 and 24. Forward sub-frame 20, rearward sub-frame 21 and horizontal stiffener 22 are preferably made from square metal tubing welded to one another in a conventional manner. Arched stiffeners 23 and 24 are preferably formed from square steel bar stock and welded at each end to the forward and rearward sub-frames. The shape of the arched stiffeners is best illustrated in FIG. 2.

A pair of brackets 25 are welded to extend forward of forward sub-frame 20, and serve as a means by which the central mower in the front row is attached to the frame. Likewise, four substantially identical brackets 25 are welded to extend forward of the rearward sub-frame 21, and serve as a means by which the central two mower units 12 in the second row are attached to the frame. Brackets 25 are preferably cut from steel bar stock, on the order of at least one quarter inch thick, and welded into place. Each of brackets 25 includes a bore that facilitates attachment of the individual mower units 12 through a pin arrangement (best illustrated in FIG. 4) that permits the individual mower units to pivot with respect to the frame about a pivot axes 38. This

aspect of the invention allows the individual mower units to independently pivot and follow contours 6 encountered as the gang mower is pulled forward over the ground 5, as shown in FIG. 2.

Hitch 13 is attached to frame 11 via a pair of brackets 26 that are substantially similar to brackets 25 discussed earlier. Brackets 26, which are partially obscured in FIG. 1 by upper brackets 126, are welded to and extend forward from forward sub-frame 20. When the gang mower is reduced to three central mower units and the mower is to be pulled by a draft animal, upper brackets 126 (see also FIG. 2) are used as the mounting location for hitch 13 via bore 127. Upper brackets 126 are welded to arched stiffeners 23 and 24. Hitch 13 includes a pair of symmetrically bent square steel bars 72 and 73. Bars 72 and 73 are bent generally into the shape shown in FIG. 1 and are welded at a number of locations along their contact surfaces. A pair of flanges 70 are attached to one end of bar 72 and 73. Flanges 70 are preferably made from steel bar stock on the order of about one quarter inch in thickness and are machined to include a bore 71, which facilitates hitching the gang mower to an ordinary garden tractor in a conventional manner. The other end of bars 72 and 73 include a bore (not shown) which facilitates the attachment of hitch 13 to brackets 26 via a pair of nut/bolts 75. Thus, hitch 13 has the ability to pivot with respect to frame 11 about axis 74 to better facilitate the gang mower following contours when going over the top of hills or the bottom of valleys between hills. Furthermore, this feature allows the hitch to be pivoted to an upright stowed position (FIG. 3) to better facilitate storing the gang mower in a relatively small space.

Attached to the rigid central frame 11 are four outer sub-frames 30. In particular, FIG. 1 shows a forward left sub-frame, a forward right sub-frame, a rearward left sub-frame and a rearward right sub-frame. Although the outer sub-frames 30 are located in different positions and inverted with respect to one another, their individual structures are substantially identical. In particular, each outer sub-frame 30 includes a length of square tubular stock welded adjacent one end to a pair of extension members 31, which are preferably cut from a length of steel bar stock on the order of about one quarter inch in thickness. Extensions 31 each include a bore that permits attachment to the central frame 11 via a nut/bolt set 36, as best shown in FIG. 4. This permits the outer sub-frames to pivot about individual horizontal axes 37a-d. This allows the outer mower units to float with the contour of the lawn independently of one another. Also, outer sub-frames 30 have the ability to pivot to an upright stowed position (FIGS. 3 and 4) in order to better facilitate storage of the gang mower in a relatively small space. Outer sub-frames 30 also include a pair of brackets 33 and 34 which are substantially similar to brackets 25 discussed earlier, except that bracket 34 is slightly longer and welded to one end of the particular outer sub-frame 30. Brackets 33 and 34 include a bore that facilitates an attachment of a mower unit 12 via a pin arrangement that permits pivoting about a horizontal axis 38. Thus, the outer sub-frames can pivot about first horizontal axes 37a-d and each of the mower units can pivot about a separate and perpendicular horizontal axis 38. This permits the outer mower units to have two degrees of rotational freedom so that gang mower can easily follow virtually any ground contour.

The individual reel-type mower units 12 are commercially available from a variety of known sources, and can be utilized without modification in the present invention. Each mower unit includes a pair of forward wheels 80 and 81 that define a localized forward axis 88. Each mower also

includes a rear roller **82** with the ability to rotate about a localized rearward axis **89**. Rear roller **82** and forward wheels **80**, **81** are interconnected via a pair of supports **87**. Rotating blades **83** are attached between supports **87** and are driven to rotate adjacent cutting bar **85** when four forward wheels **80** and **81** are rotated in the forward direction. A stabilizer bar **84** extends between brackets **87**, and apparently serves to give the individual mower unit **12** greater rigidity. The mower units also include a pair of handle mounting studs **86** which will be discussed infra in relation to FIG. 5. Thus, mower units **12** are off the shelf components except that the individual handles for the reel-type mowers are excluded. Cutting height can be adjusted by connecting the rear roller **82** to different locations along height adjustment bracket **40** (see FIG. 2 and 5). Height adjustment brackets are positioned and attached within a channel on supports **87**.

The gang mower of the present invention permits a portion of the individual mower units **12** to pivot about a pair of mutually perpendicular horizontal axes with respect to one another. Furthermore, the pivoting ability of the hitch better facilitates cutting over the top and at the bottom of relatively steep hills. However, it should be noted that none of the mower units have the ability to rotate with respect to one another about any vertical axis. This permits the user to back up the gang mower **10** without risking the jack-knifing problems encountered with prior art mower units that have the ability to rotate with respect to one another about a vertical axis. This feature also permits the mower to effectively complete zero radius turns while maintaining the proper overlapping cutting arrangement afforded by the two staggered rows of gang mowers shown in FIG. 1.

Although the gang mower **10** shown in FIG. 1 includes seven individual mower units **12**, the present invention can also utilize either five or three mowers if a thinner mower swath is desirable. In its basic form, only the central frame **11** is included with three individual mower units, giving the overall gang mower a cutting swath on the order of about four feet. The next extension up to approximately a six foot cutting swath is accomplished by adding a pair of outer sub-frames **30** to forward sub-frame **20** as discussed earlier. Such a configuration would have three mowers in the front row and two mowers in the back row and have a cutting swath on the order of about six feet or more. The next enhancement comes by adding another pair of mower units **12** to the rearward sub-frame **21** via another pair of outer sub-frames **30**. Thus, it should be clear that the present invention has the versatility to accommodate several different cutting swaths to suit virtually any individual user. Furthermore, maintenance on the present invention is relatively low since the individual mower units can be replaced at a relatively low cost and the underlying frame is virtually maintenance free. Prior art mower units are typically specially modified for use in the gang mower and often require costly maintenance and repairs when problems occur.

FIG. 3 shows the gang mower **10** of FIG. 1 in its stowed configuration for storage. Each of the outer sub-frames **30** has the capability of pivoting about its individual axis **37a-d** (FIG. 1) to an upright stowed position. The outer sub-frames **30** can be locked in their stowed configuration via the pin arrangement illustrated in FIG. 4. In particular, at the connection with each outer sub-frame **30** an upright bracket **27** is welded to the underlying sub-frame **20** or **21** (see FIGS. 1, 2 and 4). Upright brackets **27** each include a bore which aligns with bores made through extensions **31**. When in the stowed configuration, these bores align and permit the insertion of a pin **28** which is kept in place via a retaining pin

29, or another equivalent arrangement known in the art. Thus, each of the outer units is locked in an upright stowed position and the hitch is pivoted to an upright stowed position when it is desired to store the gang mower. If proper clearances are maintained, the gang mower can still be pulled forward or pushed in reverse when in its stowed configuration as shown in FIG. 3. In such a case, the weight of the gang mower, which is typically on the order of about 200 pounds, is supported by the three central mower units. Thus, the user can quickly pivot and lock the outer mower units to their stowed configuration and simply back the gang mower into a storage place within a garage or barn. Gang mower **10** takes up the space about equal to that of a motorcycle when in its stowed configuration, or less than half the space of its deployed configuration as shown in FIG. 1.

FIG. 4 is an enlarged view illustrating the interconnection between rearward right sub-frame **30** and rearward sub-frame **21**. Nevertheless, the attachment of each outer sub-frame to the central frame is identical since all the outer sub-frames are structurally identical. As discussed earlier, the framing is attached to the individual mower units via a pin arrangement **35** that permits the mower units to pivot about an axis **38**. Outer sub-frame **30** is attached to rearward sub-frame **21** via aligning bores (not shown) which receive a bolt **36a**. The bolt is secured in place with a conventional nut **36b**. When the outer sub-frame **30** is pivoted to its upright stowed configuration, the bores in extensions **31** and upright bracket **27** align and permit the insertion of a pin **28**. Pin **28** is held in place via a removable retaining pin **29** that is inserted through a hole in one end of pin **28**. When the outer sub-frames **30** are lowered into their deployed configuration, pin **28** is reinserted through bracket **27** and left in place until needed. The pin and retaining pin arrangement shown for attaching the frames to the individual mower units and for locking the outer sub-frames in an upright position could have a variety of other mechanical connections substituted therefore which are known in the art. For instance, a nut and bolt arrangement could be substituted for each of the pin/retaining pin connections illustrated.

Referring now to FIG. 5, the force distribution aspect of the present invention is contrasted with that of the closest known prior art (U.S. Pat. No. 4,287,706 to Tobin, Jr.). In particular, FIG. 5 shows a diagrammatic view of a mower unit **12** having a forward wheel **80** that is rotatable about a forward axis **88**. The rear roller **82**, which is rotatable about a rearward axis **89** is attached to the forward mower via a height adjusting bracket **40**. The present invention is preferably attached directly above rearward axis **89** so that the weight of the frame (**Wf**) is supported by the rear rollers. Although the present invention would perform well with the mowers attached either for or aft of rearward axis **89**, attaching directly above rearward roller **82** is the most easily facilitated because height adjusting bracket **40** typically includes several bores for adjusting the height of rollers **82**. Roller units **12** are preferably attached directly above roller **82**. It is also important to note that the frame is attached lower than forward axis **88** but higher than rearward axis **89**. The result being that the force (**Fp**) supplied by pulling the gang mower always intersects a line **90** connecting axis **88** and axis **89**. The result being that each individual mower unit is leveraged downward when pulled forward to increase the friction contact between drive wheels **80**, **81** and the ground. This contrasts with the Tobin connection via a bracket **111** that attaches to handle studs **86**. Handle studs **86** are typically located relatively close to forward axis **88**. Thus in

the Tobin mower, the majority of the frame's weight is supported by the forward wheels rather than the rear roller. The consequence being that the rear roller tends to bounce along the ground when the Tobin mower is pulled forward. Tobin attempted to eliminate this problem by including a spring which constantly supplies a restoring moment to maintain the rollers in contact with the ground. The present invention solves the roller bouncing problem inherent in the Tobin gang mower.

It should be understood that the above description is intended to serve only in aiding those skilled in this art to understand the present invention, and is therefore intended for illustrative purposes only. Although a number of enhancements to the present invention have been discussed above, those skilled in the art may also recognize additional enhancements to the present invention. For instance, a spiked roller could be substituted for the smooth rollers 82 illustrated for purposes of allowing the user to aerate their lawns as they mow. Another variation might be the inclusion of a slightly modified hitch so that the present invention could be pulled by a horse or other draft animal. Still another variation might be accomplished by utilizing reel-type mowers that have no rear roller. In such a case, the frame might be supported by its own rollers or wheels attached at strategic locations with the ability to adjust the height of the frame off the ground in order to adjust the cutting height of the individual mower units. Thus, while it may be preferable to use off the shelf reel-type mowers, modifications can be made to the illustrated invention without departing from the intended scope of the present invention.

Still other enhancements to the present invention might include utilizing the present frame with a plurality of golf ball retrievers substituted in place of the reel-type mower units. Such an alternative might prove attractive in retrieving balls at driving ranges. The present invention could also be utilized as a trailer for a number of other lawn implements including aerators, fertilizer units, or any other suitable lawn implement that could be substituted for the reel-type mower units illustrated. There is also the possibility of attaching implements requiring electrical power to the frame of the present invention and supplying power via a hook up to the alternator or battery of the garden tractor. This possibility may be especially attractive in attaching a number of weed eater units to the frame in order to cut any stemmy weeds or fescue grasses that are difficult to cut in a single pass with a reel-type mower. Finally, there is also the possibility of mounting a fertilizer tank on the frame and running a number of nozzles from the tank along the rearward base of the frame so that the user could distribute liquid fertilizers over their lawn while cutting. Thus, the above description is clearly not meant to limit in any way the intended scope of the present invention, which is defined solely in terms of the claims as set forth below.

I claim:

1. A gang mower comprising:

- a frame having a weight and including a central portion and a plurality of outer portions, and each of said outer portions being attached to said central portion at pivot points, and being pivotable with respect to said central portion about horizontal axes;
- a plurality of reel-type mowers having forward drive wheels that rotate about a forward axis to drive rotation of a cutting reel and a rear roller that rotates about a rear axis, and being attached to said frame in a fixed relative orientation to one another about a vertical axis, a number of said reel-type mowers being attached to said central portion of said frame, and another number of said reel-type mowers being attached to said outer portions;

means, including a positioning of said frame relative to said reel-type mowers, for causing a majority of said weight to be supported by said rear rollers.

2. The gang mower of claim **1** wherein each of said outer portions of said frame is positioned substantially behind an individual one of said another number of said reel-type mowers.

3. The gang mower of claim **2** wherein said outer portions of said frame are pivotable between a horizontal deployed position and an upright stowed position.

4. The gang mower of claim **3** wherein said frame consists essentially of:

- a plurality of metal tubing pieces attached to one another in an orientation parallel to said horizontal axes; and
- a plurality brackets attached to said metal tubing pieces.

5. The gang mower of claim **4** wherein said plurality of reel-type mowers is seven;

- three of said seven being attached to said central portion of said frame; and

- four of said seven being attached to said outer portions of said frame.

6. The gang mower of claim **5** wherein said reel-type mowers are independently pivotable with respect to one another about pivot axes that are perpendicular to said horizontal axes and said vertical axis.

7. A gang mower comprising:

- a frame that includes a forward subframe attached to, and positioned in front of, a rearward sub-frame;

a plurality of reel-type mowers each of said reel type mowers having forward drive wheels that rotate about a forward axis to drive rotation of a cutting reel and a rear roller that rotates about a rear axis, and being attached to said frame in a fixed relative orientation to one another about a vertical axis, but being pivotable about first horizontal axes that are parallel to said rear axis, and a portion being pivotable about second horizontal axes that are perpendicular to said first horizontal axes;

a first number of said reel-type mowers being positioned substantially in front of, and attached to, said forward subframe;

- a second number of said reel-type mowers being positioned substantially in front of, and attached to, said rearward subframe;

said frame being positioned such that a majority of said weight is supported by said rear rollers.

8. The gang mower of claim **7** wherein said forward subframe is attached to said rearward subframe with a plurality of rigid connecting members.

9. The gang mower of claim **7** wherein said plurality of gang mowers includes a first group of at least three attached to said forward subframe and a second group of at least three attached to said rearward subframe; and

- two of said first group and two of said second group being independently pivotable about said second horizontal axes.

10. The gang mower of claim **7** wherein said frame consists essentially of:

- a plurality of metal tubing pieces attached to one another in an orientation parallel to said first axes; and
- a plurality brackets attached to said metal tubing pieces.

11. The gang mower of claim **7** wherein said plurality of reel-type mowers is seven;

- three of said seven being attached to said frame in a fixed relative orientation about said second axes; and

four of said seven being positioned on opposite sides of said three and pivotable about different ones of said second axes.

12. The gang mower of claim 11 wherein said four are pivotable between a horizontal deployed position and an upright stowed position.

13. A gang mower comprising:

a frame having a weight;

a plurality of reel-type mowers attached to said frame and each of said reel type mowers having a rear roller and forward drive wheels to drive rotation of a cutting reel; and

means, including a positioning of said frame relative to said reel-type mowers, for causing a majority of said weight to be supported by said rear rollers.

14. The gang mower of claim 13 wherein said forward drive wheels rotate about a forward axis and said rear roller rotates about a rear axis; and

said frame producing a force on each of said reel-type mowers that intersects a line connecting said forward axis to said rear axis, when said frame is pulled forward.

15. The gang mower of claim 13 wherein said frame includes a forward subframe attached to a rearward subframe;

said plurality of reel-type mowers including at least two attached to, and substantially in front of, said forward

subframe and at least two attached to, and substantially in front of, said rearward subframe.

16. The gang mower of claim 13 further comprising means, including said frame, for leveraging said forward wheels of said reel-type mowers downward when said frame is moved forward.

17. The gang mower of claim 13 wherein said frame is substantially rigid with respect to a vertical axis such that a relative positioning of said reel-type mowers in a plane perpendicular, to said vertical axis remains substantially constant regardless whether said gang mower is being moved forward around curves or moved backward.

18. gang mower of claim 13 wherein each of said reel-type mowers is attached to said frame at pivot points; and said reel-type mowers being pivotable with respect to said frame about horizontal axes.

19. The gang mower of claim 13 wherein said frame includes a central portion and a plurality of outer portions; each of said outer portions being attached to said central portion at pivot points;

said outer portions being pivotable with respect to said central portion about horizontal axes that are perpendicular to said rear roller.

20. The gang mower of claim 13 wherein a portion of said plurality of reel type mowers can pivot between a horizontal deployed position and an upright stowed position.

* * * * *

UNITED STATES PATENT AND TRADEMARK OFFICE
CERTIFICATE OF CORRECTION

PATENT NO. : 5,865,017
DATED : Feb. 2, 1999
INVENTOR(S) : Douglas Short

It is certified that error appears in the above-identified patent and that said Letters Patent is hereby corrected as shown below:

In claim 7, line 20, after the word "frame",
insert the phrase --having a weight and--.

Signed and Sealed this
Twenty-seventh Day of July, 1999

Attest:



Q. TODD DICKINSON

Attesting Officer

Acting Commissioner of Patents and Trademarks