



US005854190A

United States Patent [19]

[11] Patent Number: **5,854,190**

Knipe, Jr. et al.

[45] Date of Patent: **Dec. 29, 1998**

[54] **WATER-BASED FLUSHING FOR PAINTS AND OTHER COATINGS**

[75] Inventors: **Richard E. Knipe, Jr.**, Montebello, N.Y.; **Savarimuthu M. Jacob**, Edison; **Thomas Mancini**, Lincoln Park, both of N.J.

[73] Assignee: **DALCO Industries, Ltd.**, Spring Valley, N.Y.

4,140,647	2/1979	Mizutani et al.	252/89
4,749,510	6/1988	Nelson	252/166
5,158,710	10/1992	VanEenam	252/539
5,202,049	4/1993	Bingham	252/162
5,250,230	10/1993	Steele et al.	252/544
5,334,331	8/1994	Fusiak	252/542
5,393,451	2/1995	Koetzle	252/170
5,494,594	2/1996	Rodzewich	252/49.3
5,498,805	3/1996	Koetzle	568/827
5,631,216	5/1997	Morris et al.	510/276
5,747,439	5/1998	Dunn et al.	510/255

[21] Appl. No.: **950,615**

[22] Filed: **Oct. 15, 1997**

Primary Examiner—Paul Lieberman
Assistant Examiner—Gregory E. Webb
Attorney, Agent, or Firm—Notaro & Michalos P.C.

Related U.S. Application Data

[62] Division of Ser. No. 784,315, Jan. 16, 1997, Pat. No. 5,701,922.

[51] **Int. Cl.**⁶ **C11D 1/66; C11D 3/08**

[52] **U.S. Cl.** **510/241; 510/202; 510/212; 510/252; 510/272; 510/421; 510/435; 510/437**

[58] **Field of Search** 510/212, 202, 510/505, 206, 201, 241, 252, 272, 421, 435, 437; 134/38

[57] ABSTRACT

An apparatus, method and purge concentrate are capable of purging water-based and non-water-based paints and other coatings from automated and manual equipment using non-VOC containing aqueous purge solutions. Purge solutions of the invention contain water, detergent builder and wetting agents. The solution is maintained at a selected concentration and at a selected elevated temperature range by continuously recirculating the solution through the automated coating equipment. For manual equipment the solution is set at the correct concentration and maintained at the correct temperature range. For an automated system, spent purge solution can be reconditioned and recirculated to avoid waste.

[56] References Cited

U.S. PATENT DOCUMENTS

2,975,140	3/1961	Yaroch	252/110
4,062,814	12/1977	Hansen	252/529

7 Claims, 3 Drawing Sheets

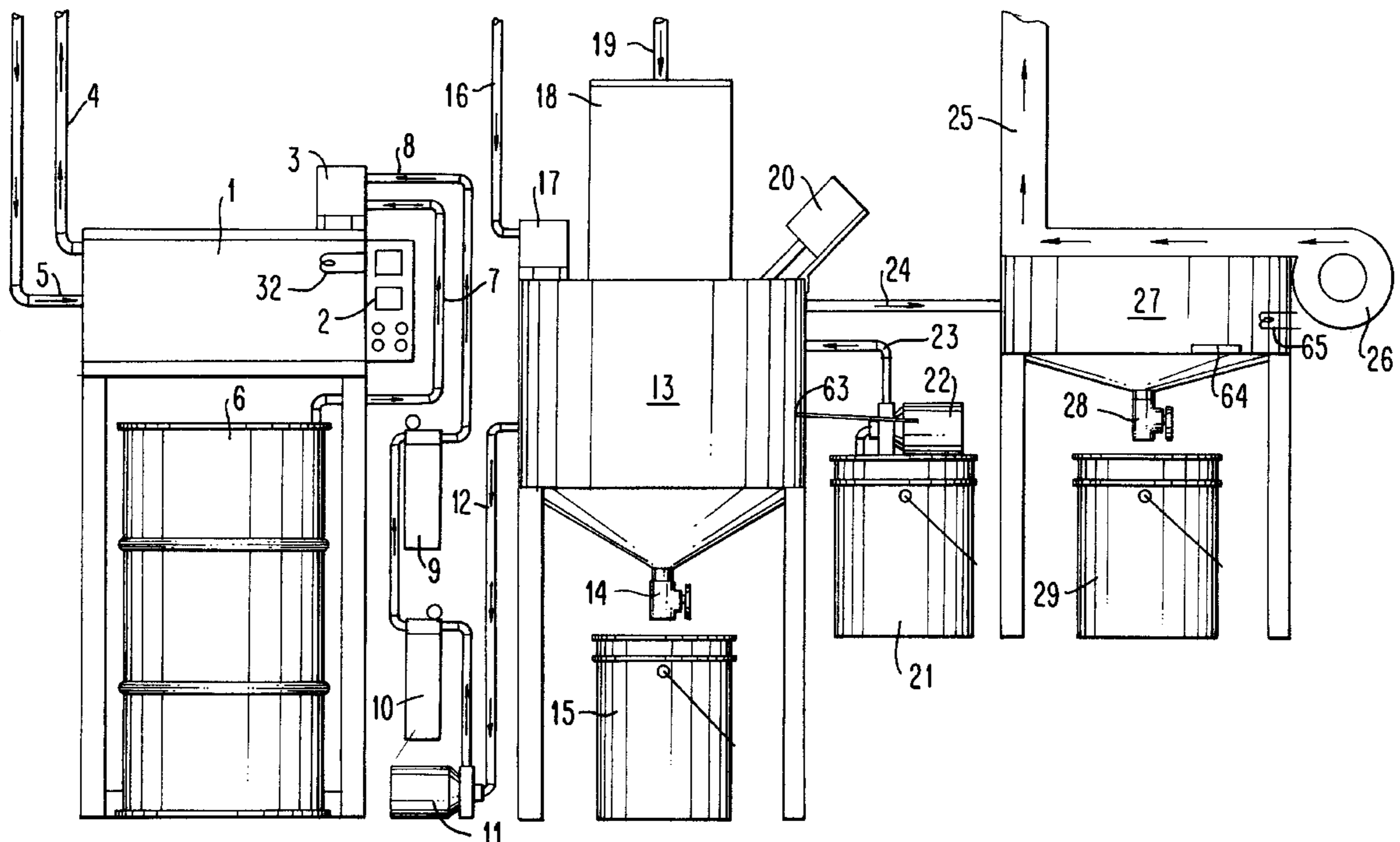

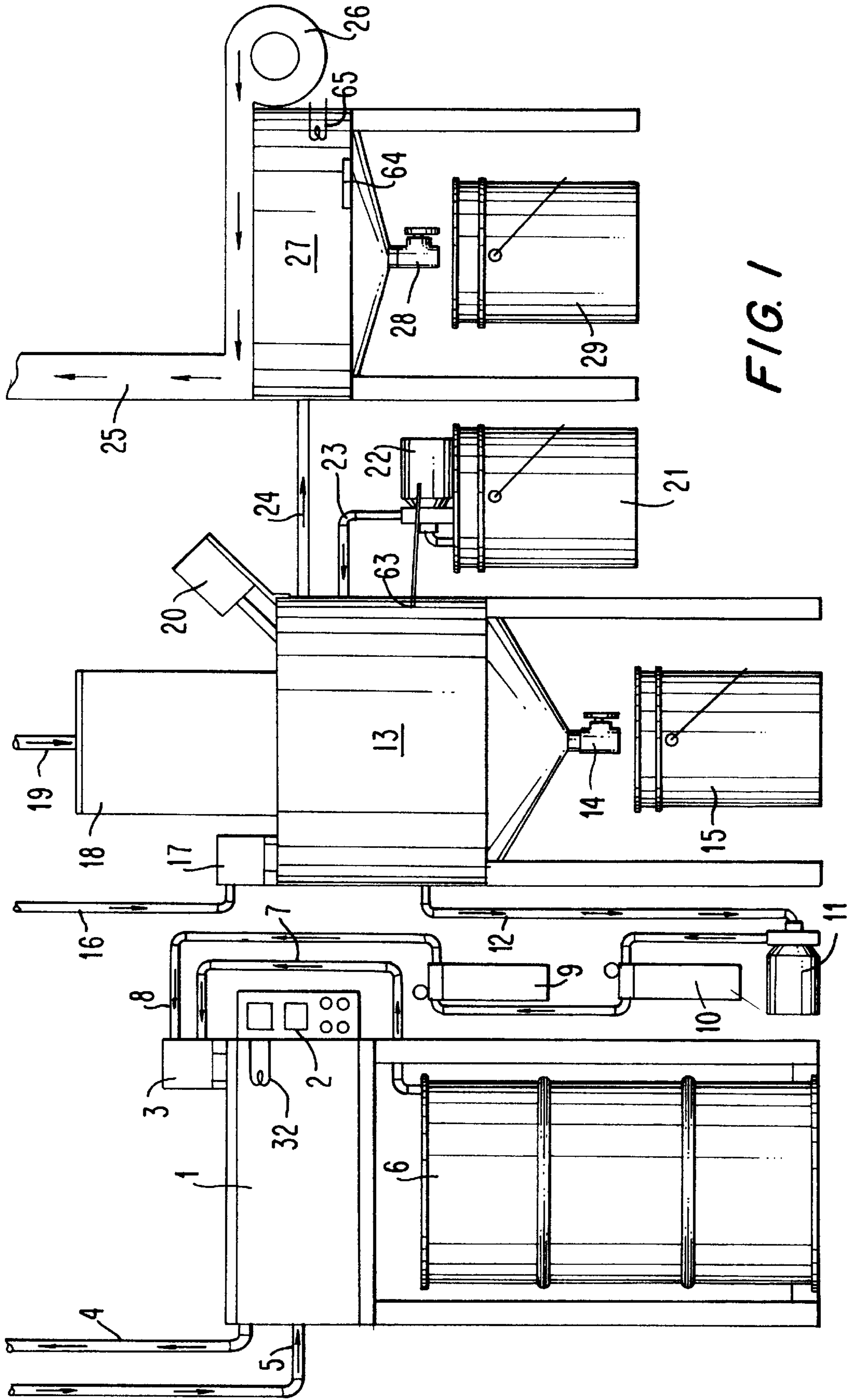

FIG. 1

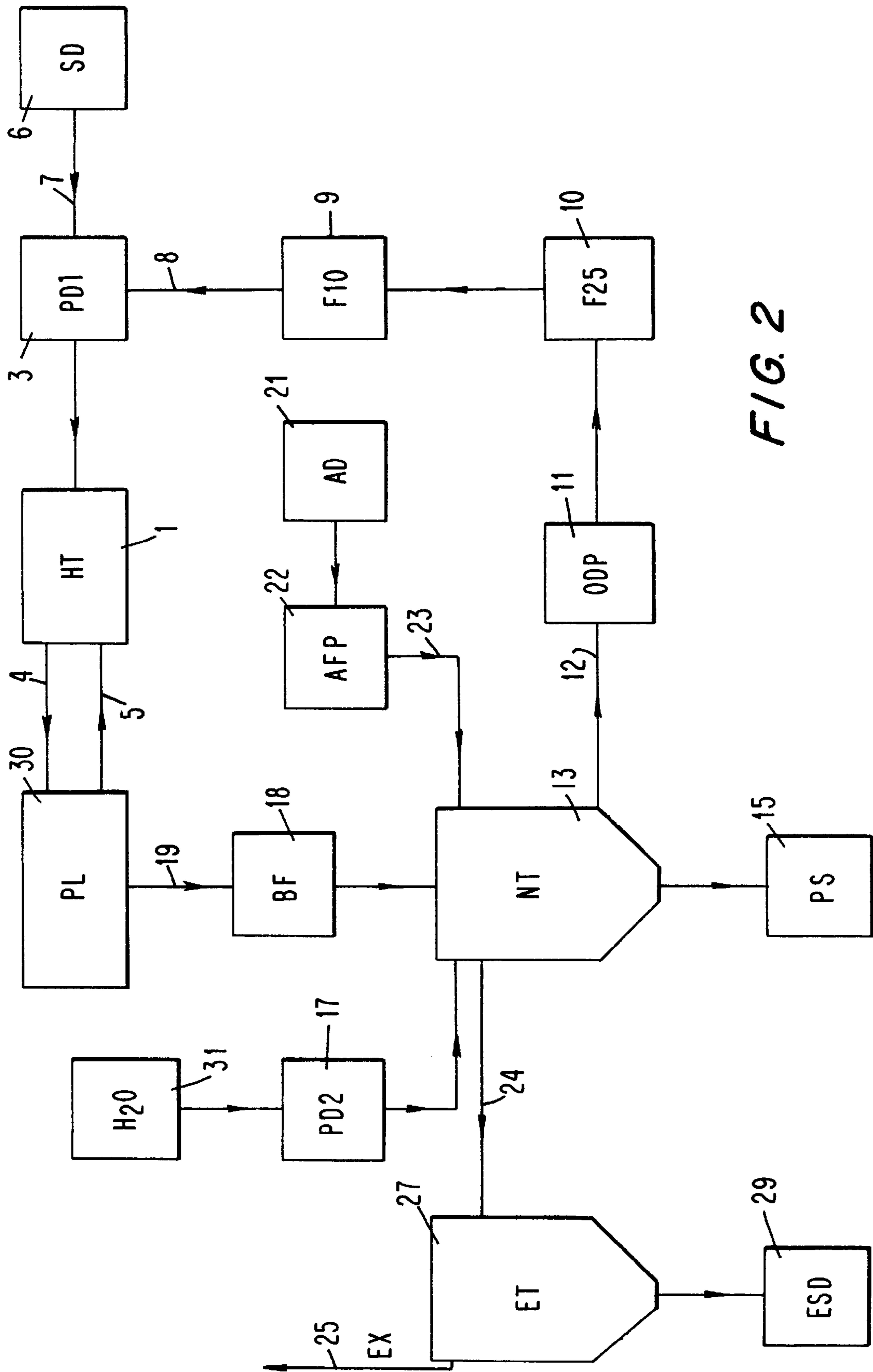

FIG. 2

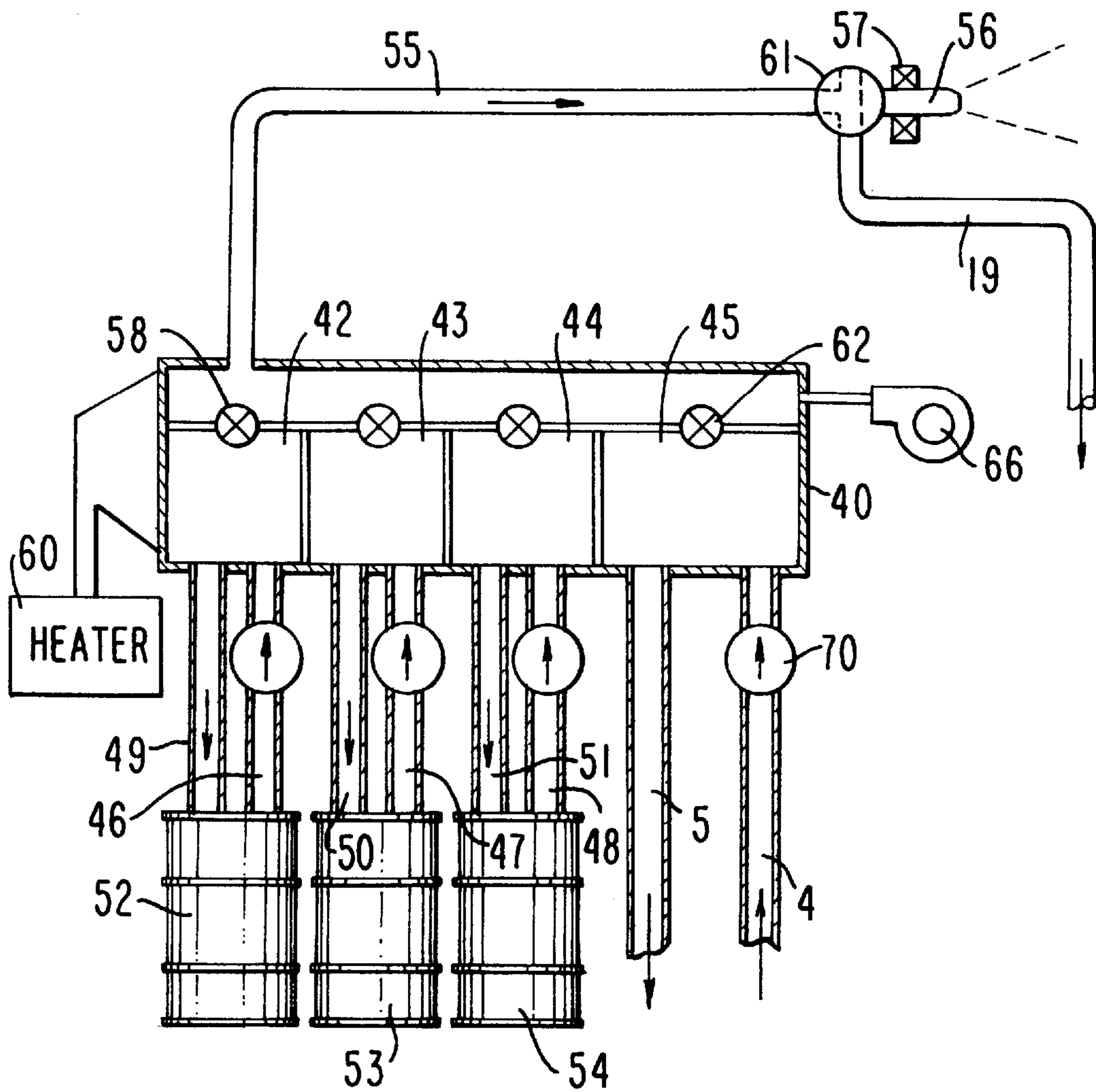

FIG. 3

WATER-BASED FLUSHING FOR PAINTS AND OTHER COATINGS

This application is a division of application Ser. No. 08/784,315, filed Jan. 16, 1997, now U.S. Pat. No. 5,701,922.

FIELD AND BACKGROUND OF THE INVENTION

The present invention relates in general to compositions, methods and apparatuses for flushing paints or other coatings from equipment such as automated and manual paint sprayers and paint dip installations, and in particular to a new a useful composition, method and apparatus which uses water-based flushing to completely avoid the need for volatile organic compound (VOC) solvents, which have conventionally been used for flushing paints and other coatings, in particular, non-water-based paints and other coatings.

It is known to purge automated paint sprayers and paint dip equipment during maintenance and color changes using solvents based on:

Alcohol	Fluorinated Hydrocarbon
Terpene	Aliphatic Hydrocarbon
Chlorinated solvent	Aromatic Hydrocarbon

All of these solvents are considered hazardous and most forms are considered to be volatile organic compounds or VOC's. They may be used in the 100% pure form or as blends, using combinations of the solvents.

VOC's are heavily regulated by the Environmental Protection Agency (EPA). The EPA regulates the amount of VOC which any particular company can emit into the atmosphere. This ceiling limits the production output of the company which, in particular, when automated equipment is used, it is much less than the total output that the company may be capable of sustaining without such regulations. The ceiling is particularly difficult to deal with also because these companies use paints which themselves contain high percentages of VOC solvents. The solvent percentages range from 5% to 80%, depending on the paint.

Current paints and other coatings fall into six categories as follows:

Epoxy	Polyester	Polyurethane
Polyamid	Enamels	Water Borne

For the purpose of this disclosure, paints will be grouped into the general category referred to as coatings, which may include not only paints but other liquids meant to be coated onto surfaces. Coatings, in turn, are divided generally into VOC coatings containing some VOC solvents and non-VOC coatings, such as water-borne coatings.

Various automated and manual devices, equipment and techniques are known for applying coatings onto structures. Among these is the use of electrostatic spraying equipment which pumps paint from a holding vessel or drum and sprays the paint through a manual air gun or automated, robot controlled, reciprocating paint nozzle, disc or bell-shaped applicator. The paint may also be pumped to a dip tank which applies the coating by dipping structures into the tank. For electrostatic coating, the paint is charged with 20,000 to 80,000 volts and applied to a grounded structure or substrate to be coated. The advantage to electrostatics is that it allows

most of the coating to go directly onto the substrate and minimizes over-spraying and excess air emissions.

The use of electrostatic spraying thus reduces VOC discharge and permits high-volume application of coatings while still remaining within the strict EPA regulations. This technique also reduces the amount of paint used during the operation,

When a new color is needed for the substrates, all paint lines containing the last color must be purged. Currently this is done by drawing solvent from a holding vessel or drum and circulating it through the system lines and out through the sprayers or drains. Some of the solvent may be recirculated while a remainder of the solvent is disposed of as a hazardous waste. A new color is then introduced into the system. Problems associated with these types of solvents, whether they are VOC or not, include flammability, toxic fume exposure to employees, evaporative losses and odors.

One example of an electrostatic nozzle and other equipment particularly suited for robot-controlled coating, is manufactured by Binks Manufacturing Company of Franklin Park, Ill. One such nozzle supplied by Binks is known as the Mini-Mizer series, which is a high-speed circumferential atomizer, especially suited for atomizing high-solids coatings, water-borne coatings and conventional solvent base coating systems.

Due to the presence of high voltage, a serious problem which occurs, in particular, during the purging operation, is the problem of arcing. Both the nozzles and the hoses and lines connected to the nozzles can pick up charges and pose an arcing hazard. Although conductive materials can be sprayed with the Mini-Mizer nozzle, the manufacturer of the nozzle advises users to utilize an extra degree of electrical insulation from ground, for the spray equipment.

One company which is involved in the spraying of substrates and which must comply with EPA regulations concerning emissions, is Lozier, which operates from seven different locations and which utilizes robotic spray booths. It is estimated that a company like Lozier would utilize approximately 4,000 gallons of cleanser per month for its seven locations for exclusive use in purging the spray equipment. It is common to require on the order of 40 color changes per day, switching colors among approximately 180 available colors. Each color change must be followed by a purge cycle which is as quick and effective as possible to permit quick restarting of the spraying equipment with a new color.

Eliminating VOC's and other undesirable components from the purging fluid, would represent a substantial improvement in the field, resulting in increased production rates which are still within the EPA requirements.

SUMMARY OF THE INVENTION

The main object of the present invention is to provide a composition, method and equipment for replacing any and all objectionable solvent blends which are currently used to purge automated and manual coating equipment, with a composition, method and apparatus using water-based purging fluid.

Two basic problems which were overcome according to the present invention were the formulation and conditions by which a water-based product can be used to purge coatings, whether they are VOC or non-VOC based. Another problem was to provide a composition and conditions which can operate within an electrostatic environment, without causing arcing or other electricity related problems.

Both have been overcome by the present invention.

Another object of the present invention is to provide a composition, method and equipment which utilizes water-based purging fluids which do not have the problems of flammability, toxic fumes, evaporative losses or odor.

Another object of the present invention is to provide a coating purge composition which is an aqueous biodegradable solution which replaces the prior noxious flushing solvents and which can be used in a process which establishes a proper working strength and effective purging conditions, including elevated temperature, and proper water dilution rates for the purging fluid. The apparatus of the invention maintains the correct dilution rate and temperature, as well as regenerating the purged fluid by separating from the purged coating, reconditioning it and returning it to a reservoir which contains the purge fluid under proper conditions for reuse. The invention thus also encompasses equipment for storing, supplying, conditioning, regenerating and recycling the aqueous fluid.

The various features of novelty which characterize the invention are pointed out with particularity in the claims annexed to and forming a part of this disclosure. For a better understanding of the invention, its operating advantages and specific objects attained by its uses, reference is made to the accompanying drawings and descriptive matter in which the preferred embodiments of the invention are illustrated.

IN THE DRAWINGS

FIG. 1 is a schematic representation of the equipment of the present invention;

FIG. 2 is a schematic representation of a closed loop coating purge system, also according to the present invention; and

FIG. 3 is a schematic representation of a painting system with paint change manifold which incorporated the purge system of the present invention.

DESCRIPTION OF THE PREFERRED EMBODIMENTS

Referring to FIG. 1, in particular, the invention embodied therein comprises an apparatus for purging coating equipment such as paint lines, paint apparatus and paint sprayers. The apparatus of the invention includes a purge concentrate supply container, such as a supply drum 6 which contains the unique aqueous purge concentrate of the present invention, and a fresh purge concentrate line 7 connected to a dilution proportioning device 3 which receives dilution water from a line 8. The apparatus of the invention further includes a purge solution tank 1 for receiving metered amounts of the dilution water and purge concentrate. The proportioning device 3 is utilized to form a purge solution in the tank 1, the purge solution being a solution of the purge concentrate from drum 6 and the dilution water from supply line 8 at a carefully controlled and selected concentration range. In addition to the concentration range for the purge solution in tank 1, it is important to maintain a selected elevated temperature range for the solution in the tank. This is achieved using a heater 32. Throughout the system various level sensors, temperature sensors and other electronic or electromechanical devices are utilized. These are all connected to a system control 2. Both mechanical and electrical controls are included and are advantageously controlled by microprocessor. The microprocessor is also used to operate the various pumps, heaters, mixers, blowers and other necessary plumbing to control the apparatus and process of the present invention.

An example of the solution proportioning device 3, is a venturi valve with the dilution water flow from line 8 being

supplied at sufficient pressure, as controlled by a demand pump 11, to draw a correct metered amount of purge concentrate from drum 6 and along line 7. Other concentration range proportioning devices may also be utilized to control the concentration of the purge solution in tank 1, however.

It is also noted that the purge concentrate in supply tank 6, according to the unique water-based, VOC-free composition of the present invention, contains a mixture of water, a non-VOC detergent builder, such as a silicate or an amine, and a wetting agent which contributes a detergent effect. In the case of silicates or analogous detergent builders, an elevated alkalinity is required in conjunction with the neutral wetting agent. No such elevated alkalinity is required when using an amine as the detergent builder, such as mono ethanol amine. The use of amine, which is neutral, is important especially where electrostatic paint equipment is involved, since its reduced conductivity is important to avoid problems associated with passing conductive liquids through the electrically chargeable apparatus. Although charges are usually removed during the purging phase, residual charges may exist, which may cause arcing and other electricity associated problems if an overly conductive purging solution is utilized,

Returning to the apparatus of the invention shown in FIG. 1, purge solution tank 1 is connected by a fresh solution supply line 4 to a paint manifold arrangement of coating equipment to be purged according to the present invention. The solution returns from that manifold along a return line 5, also connected to tank 1.

A pump 70 in FIG. 3., associated with the manifold 40 recirculates the heated solution from tank 1, to the manifold and back along lines 4 and 5. It is noted that the level of purge solution in tank 1 is controlled by a float (not shown) connected to the proportioning device 3. When the level falls, the float pulls an actuator in the venturi valve which starts the flow of water along line 8 by starting demand pump 11, and automatically draws proportioned amounts of fresh concentrate along line 7.

It is critical that the temperature be elevated and maintained at a selected elevated temperature range by heater 32 in tank 1, and throughout the recirculation system between tank 1 and the manifold 40 shown in FIG. 3. This maintains a supply of heated purge solution at correct concentration and that is continuously circulated. This also contrasts the present invention from prior art purge systems which simply blow VOC solvent through paint lines of the coating apparatus to purge the paint. It is noted that an advantageous temperature range for the purge solution is between about 100° F. and 160° F. It is also advantageous to maintain a dilution of purge concentrate with waters, at a strength of about 5% to 50% by weight. The temperature range and concentration are continuously monitored and adjusted by control system 2.

Another advantage of the invention is that it utilizes the existing heated manifold 40, which is used in some automated spray applications. Such a manifold advantageously includes multiple chambers 42, 43, 44 and 45, each including an inlet with a pump, shown at 46, 47 48 and additional line 4. Return lines 49, 50 and 51, connect manifold chambers 42, 43 and 44 to separate paint drums 52, 53 and 54, which advantageously contain paints of different colors. The points are viscous and must be maintained at an elevated temperature, for example, at about 120° F., to reduce the viscosity and to allow the paint to be easily supplied along a paint supply line 55 and to be sprayed through an atomizer

or spray nozzle **56**. For electrostatic spraying a charging head **57** is also provided for charging the nozzle to levels of 20,000 to 80,000 volts, typically. According to the present invention, the same circuitry and pumps which are used to maintain the elevated temperatures for the various paints so that a quick color change can be achieved, are also utilized for the supply and return lines **4**, **5**, for supplying and returning the purge solution of the present invention.

According to the present invention a supplemental heater **60** is utilized in conjunction with manifold **40** to maintain the elevated temperatures, both for the circulating paint and the circulating purging solution. In order to spray with a paint having a color in drum **52**, valve **58** is opened which communicates chamber **42** with point line **55**. A purge valve **61**, which is shown in a purge position, is rotated into a paint supply position so that paint from drum **52** is supplied through nozzle **56** after it has picked up an electric charge from charging head **57**. The paint is then effectively sprayed onto a substrate which is held at ground potential so that the paint is electrically attracted to the substrate. When a paint change to another color is required, for example, the paint in drum **53**, valve **58** is closed and a valve **62** is opened for communicating purge chamber **45** with the paint line **55**. Purge valve **61**, for example, a T-valve, is rotated into the position shown in FIG. **3** so that the purge solution which is now burdened with paint and is thus a spent solution, is supplied along a dump line **19** to a neutralizing tank **13**, in the apparatus of FIG. **1**.

For a short time thereafter, valve **61** is rotated into a position communicating line **55** with nozzle **56** and a small amount of purge solution is sprayed through the nozzle to clean the nozzle. This solution also becomes spent, but it is only a very small amount which falls onto the floor of the paint booth and is not recirculated.

Returning to the apparatus of FIG. **1**, the spent purge solution on line **19** is supplied to a bag filter **18** which removes a large percentage of the paint solids from the spent solution. The now filtered solution is supplied to a neutralizing tank **13**, where it's pH is sensed using conventional pH testing and acid supplying equipment. If the pH is too high, it is decreased by adding acid, such as 10% dilute sulfuric acid from an acid drum **21** by an acid feed pump **22** along an acid feed line **23**. Acid pump **22** is connected to the pH sensor shown schematically at **63** and is a commercially available apparatus. Acid pump **22** and sensor **63** are set to neutralize the solution in tank **13** to about 7.5 pH.

Additional paint separation takes place in tank **13** by virtue of the fact that the paint settles to the bottom of the tank where this paint sludge can be discharged by opening a paint sludge dump valve **14**, which discharges the paint sludge into a paint sludge drum **15**. Fresh make-up water is supplied over pressurized water line **16** through a second proportioning device **17**, which senses the level of liquid in neutralizing tank **13** and if insufficient liquid is available, opens line **16** until the correct level is reached. A mixer **20** is also provided for mixing the contents of the neutralizing tank to condition the recirculated purge solution.

As controlled by demand pump **11**, which in turn is controlled by the level sensor in tank **1**, reconditioned dilution water is supplied from tank **13** along line **12** to a first filter **10**, which in a preferred embodiment of the invention is a 25 micron filter. This is connected in series to a second 10 micron filter **9**, which then supplies the filtered dilution water to line **8**.

It is noted that bag filter **18** must be cleaned periodically and filters **9** and **10** must be replaced periodically.

Together, elements **13–23** form conditioning means of the present invention for conditioning the recirculated spent solution.

The apparatus of the present invention shown in FIG. **1** also includes an overflow line **23**, which is connected between the top of neutralizing tank **13** and an evaporation tank **27**, which contains an air agitator **64** and a heater **65** for heating and agitating the overflow from neutralizing tank **13**. Evaporating tank **27** is used in case too much neutralizing solution has accumulated in tank **13**. The overflow solution is converted into vapor and removed by a blower **26** and duct **25**.

Any residue in evaporator tank **27** can be discharged periodically by opening an evaporator drain **28**, which discharges into an evaporator sludge drum **29**.

FIG. **2** illustrates the process of the present invention. It is noted that throughout the figures the same reference numerals are used to designate the same or functionally similar parts.

As shown in FIG. **2**, heating tank **1** recirculates heated solution at the selected concentration **1** and from the coating equipment (e.g., paint lines PL) shown schematically at **30**. When a purge cycle is required between a color change, spent solution is discharged from equipment **30** along dump line **19** to bag filter **18**, and thereafter to neutralizing tank **13**. pH control equipment in the form of acid drum **21** and acid pump **22** supply acid along line **23** to maintain the proper pH of the reconditioned solution in tank **13**. The reconditioned solution is allowed to reside in tank **13** for a time to allow additional solids to settle out and be discharged over gate a valve (**14** in FIG. **1**) into paint sludge drum **15**. Make-up water from a water supply **31** can be provided over line **16** to liquid level proportioning device **17** and thereafter to tank **13**. Overflow line **24** supplies overflow liquid from tank **13** to evaporator tank **27** which has a lower discharge to evaporator sludge drum **29** and an upper discharge to exhaust duct **25**. On demand, pump **11** supplies reconditioned dilution water from line **12** to the series connected filters **10** and **9**, thereafter to water supply line **8** and the first liquid proportioning device **3**. Supply drum **6** provides the metered amount of purge concentrate along line **7**, and the concentrate with correct concentration range is supplied to heating tank **1**.

Typical purge sequences for automated equipment such as the equipment shown in FIG. **3**, includes a combination of purging with compressed air and with purge solution. Compressed air can be supplied by blow **66** as shown in FIG. **3**, and discharged through a port of valve **61** which is opposite from line **19**. The sequence may be as follows:

Time Value(s)	Sequence Function
3 to 10 Seconds	Compressed Air Purge
3 to 15 Seconds	Solution Purge
3 to 10 Seconds	Compressed Air Purge
3 to 10 Seconds	Purge Solution to Dump Line 19
3 to 10 Seconds	Compressed Air Purge Through Dump Line 19
2 to 5 Seconds	Polychem Product Purge Through Sprayer 56
10 to 20 Seconds	Compressed Air Purge Through Sprayer 56

Additional valving may be utilized to divert the compressed air through the various lines for achieving the sequence function.

For non-automatic lines, the solution of the present invention is used from a container and is still functional as long

as the solution is maintained at its elevated temperature. Generally, greater compression purge cycles are needed, for example, from 5 to 10 seconds.

Preferred embodiments of the compositions of the present invention which can satisfy the non-volatile, aqueous purge concentrate requirements are as follows:

Purge Concentrate 1st Formula		
Wt. %	Ingredients	Acceptable Ranges
83.48	Water	88.99-72.0
3.00	Glucosheptonic Acid Sodium Salt	1.0-7.0
0.08	Sodium Methyl Naphthalene Sulfonate	0.01-1.0
13.44	Sodium Silicate	10.0-20.0

Purge Concentrate 2nd Formula				
Formula	Ingredients	Wt. %	Acceptable Ranges	Wt. %
1.	Water	78.90	1. Water	75-85
2.	Caprylic Acid	0.60		
3.	2-Butoxy Ethoxy Acetic	2.00	3. Carboxylic Acid Salt	1-5
4.	Potassium Hydroxide, 45%	7.00		
5.	Modified Ethoxylated Surfactant	2.00	5. Modified Ethoxylated Surfactants	1-5
6.	Anionic Phosphate Ester	0.50	6. Phosphate Ester	1-5
7.	Glucosheptonic acid, Sodium Salt	2.00	7. Sodium Salt of Glucosheptonic acid	1-5
8.	Sodium Silicate	4.00	8. Sodium Silicate	1-5
9.	Tetra Potassium Pyrophosphate	3.00	9. Tetra Potassium Pyrophosphate	1-5

Purge Concentrate 3rd Formula				
Formula	Ingredients	Wt. %	Acceptable Ranges	Wt. %
1.	Water	80.5	1. Water	80-90
2.	Triethanol Amine N (C ₂ H ₅ OH) ₃	3.0	2. Carboxylic Acid Soap	1-5
3.	Dodecyl Benzene Sulfonic acid	1.0		
4.	Nonylphenol Ethoxylate	1.0	4. Nonylphenol Ethoxylate	1-5
5.	Mono Ethanol Amine C ₂ H ₄ OHNH ₂	6.0	5. Mono Ethanol Amine	3-8
6.	Poly Ethyleneoxy Glycol	3.0	6. Polyoxy Alkylene Glycol (Polyol)	1-5
7.	Phosphate Ester	3.0	7. Phosphate Ester	1-5

-continued

8.	Boric Acid, Sodium Salt	0.5	8.	Boric Acid, Sodium Salt	1-3
9.	Modified Ethoxylate Surfactant	1.0	9.	Ethoxylated Alcohol	1-3
10.	Tetra Potassium Pyrophosphate	1.0	10.	Tetra Potassium Pyrophosphate	1-3

10 In general, however, the purge concentrate of the present invention is a non-VOC water-based concentrate containing about 70 to 90 wt. % water, from about 1 to about 20 wt. % detergent builder and about 0.01 to 7% wetting agent. Other components may also be added to augment the ability of the concentrate to purge coatings, including VOC containing, non-VOC containing and water-based coatings. The concentrate is used in a dilution of 5% to 50% in water and at a temperature of 100° F. to 160° F. While the specific embodiments of the invention have been shown and described in detail to illustrate the application of the principles of the invention, it will be understood that the invention may be embodied otherwise without departing from such principles.

What is claimed is:

25 1. A purge concentrate for purging coating equipment, comprising:

about 75%-85% by weight water;

about 1%-20% by weight sodium silicate;

30 about 0.01%-7% by weight modified ethoxylated surfactant; and further comprising potassium hydroxide and a sodium salt of glucosheptonic acid.

2. A purge concentrate according to claim 1, including an organic acid.

35 3. A purge concentrate according to claim 2 including a carboxylic acid salt.

4. A purge concentrate according to claim 3 wherein the organic acid comprises caprylic acid.

40 5. A purge concentrate according to claim 2 including an anionic phosphate ester.

6. A purge concentrate according to claim 5 wherein the organic acid comprises caprylic acid.

7. A purge concentrate according to claim 1 including tetra potassium pyrophosphate.

* * * * *