



US005843374A

United States Patent [19]

Sizer et al.

[11] Patent Number: **5,843,374**

[45] Date of Patent: **Dec. 1, 1998**

[54] METHOD AND APPARATUS FOR STERILIZING PACKAGING

[75] Inventors: **Charles Sizer**, Hawthorne Woods;
Sevugan Palaniappan, Grayslake;
Victor Holbert, Buffalo Grove, all of Ill.

[73] Assignee: **Tetra Laval Holdings & Finance, SA**, Pully, Switzerland

[21] Appl. No.: **756,850**

[22] Filed: **Nov. 26, 1996**

Related U.S. Application Data

[63] Continuation-in-part of Ser. No. 728,723, Oct. 11, 1996.

[51] Int. Cl.⁶ **A61L 2/00**

[52] U.S. Cl. **422/24; 422/28; 422/31; 53/425**

[58] Field of Search **422/24, 28, 31; 53/425**

[56] References Cited

U.S. PATENT DOCUMENTS

3,738,080	6/1973	Reil	53/180
3,911,642	10/1975	Ernstsson et al.	53/28
4,069,753	1/1978	Gunther	210/64
4,121,107	10/1978	Bachman	250/455
4,289,728	9/1981	Peel et al.	422/24
4,366,125	12/1982	Kodera et al.	422/295
4,375,145	3/1983	Mosse et al.	53/425
4,448,750	5/1984	Fuesting	422/20
4,590,740	5/1986	Rodocker	53/426
4,656,813	4/1987	Baldini et al.	53/410
4,797,255	1/1989	Hatanaka et al.	422/28
4,809,485	3/1989	Nielsen	53/503
4,848,063	7/1989	Niske	53/451
4,896,768	1/1990	Anderson	206/210
4,910,942	3/1990	Dunn et al.	53/425
5,073,268	12/1991	Saito et al.	210/638
5,122,340	6/1992	Shimamura et al.	422/28
5,129,212	7/1992	Duffey et al.	53/426
5,135,714	8/1992	Wang	422/23

5,144,670	9/1992	Negishi	381/439
5,155,980	10/1992	Mansson et al.	53/551
5,158,816	10/1992	Rausing	428/35.8
5,213,759	5/1993	Castberg et al.	422/44
5,248,665	9/1993	Schulte et al.	210/748
5,326,542	7/1994	Sizer et al.	422/291
5,350,568	9/1994	Tuckner et al.	422/300
5,428,078	6/1995	Cohen et al.	522/2
5,433,920	7/1995	Sizer et al.	422/24
5,445,793	8/1995	Tuckner et al.	422/28
5,489,022	2/1996	Baker	206/439
5,494,691	2/1996	Sizer	426/392

FOREIGN PATENT DOCUMENTS

9218170 10/1992 WIPO .

Primary Examiner—Edward J. Cain
Attorney, Agent, or Firm—Michael A. Catania

[57] ABSTRACT

A method and apparatus for sterilizing packaging through irradiation with an excimer ultraviolet lamp which may be integrated on a packaging machine. The excimer ultraviolet lamp emits radiation at a substantially monochromatic wavelength within the ultraviolet band of the electromagnetic spectrum. The excimer ultraviolet lamp is composed of a quartz shell containing one of the following gaseous compounds: Ar₂, Kr₂, Xe₂, ArCl, KrCl, KrF or XeCl. The KrCl gas excimer ultraviolet lamp which generates a wavelength of 222 nanometers is of particular interest for the present invention. In one embodiment, the lamp has a central aperture for flowing through a cooling fluid to remove heat from the lamp. If the excimer ultraviolet lamp is integrated on a form, fill and seal machine, the cooling fluid may be the desired contents filled into a container fabricated on the form, fill and seal machine. The materials sterilized by the present invention are fabricated into many different containers such as flexible pouches, stand-up pouches, parallelepiped containers and gable top cartons. The material may be subjected to a sterilant prior to irradiation by the excimer ultraviolet lamp. The sterilant may be hydrogen peroxide, peracid, ozone or the like. The concentration of the sterilant may have a range of between 1% to 55%.

19 Claims, 8 Drawing Sheets

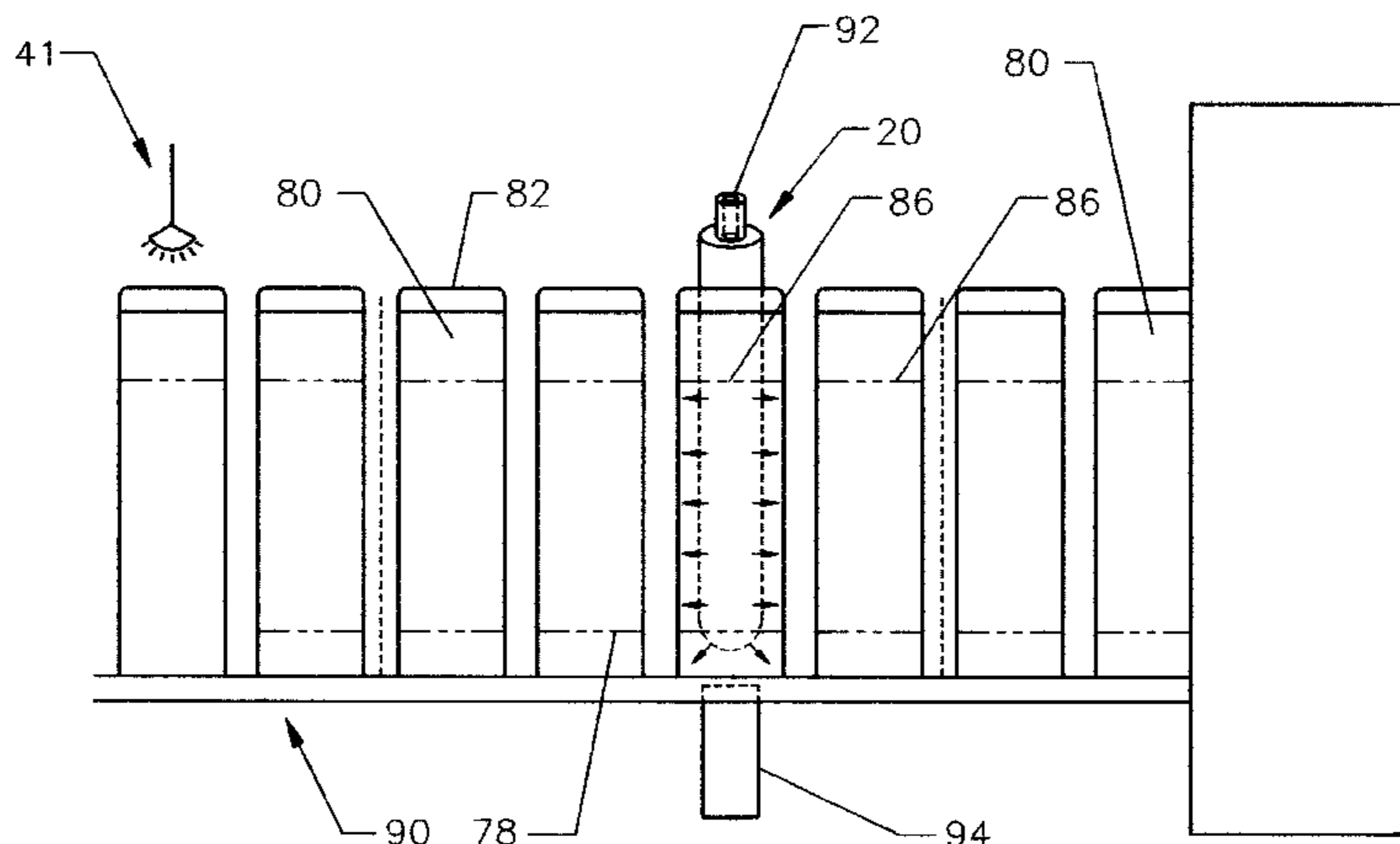

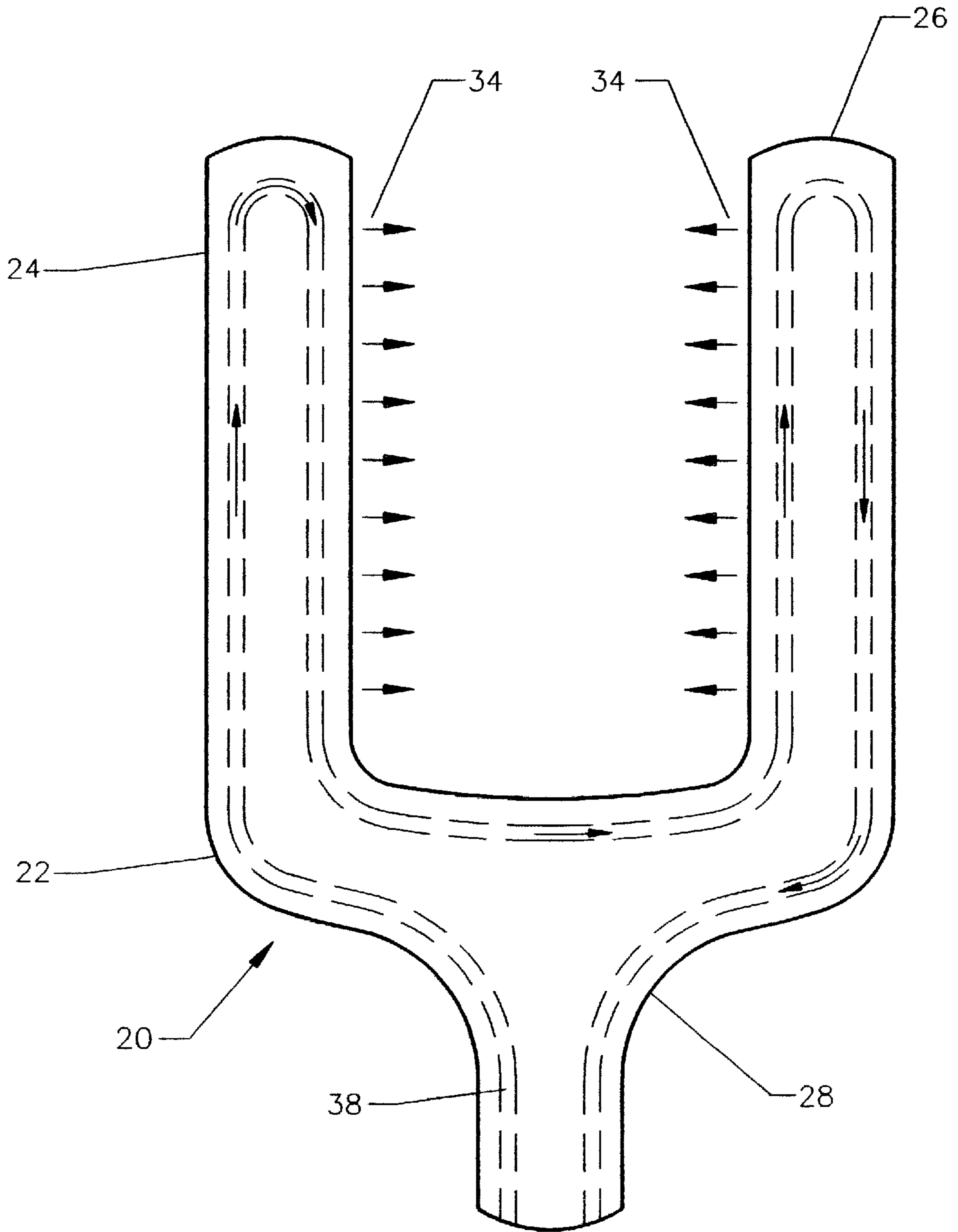

Fig. 1

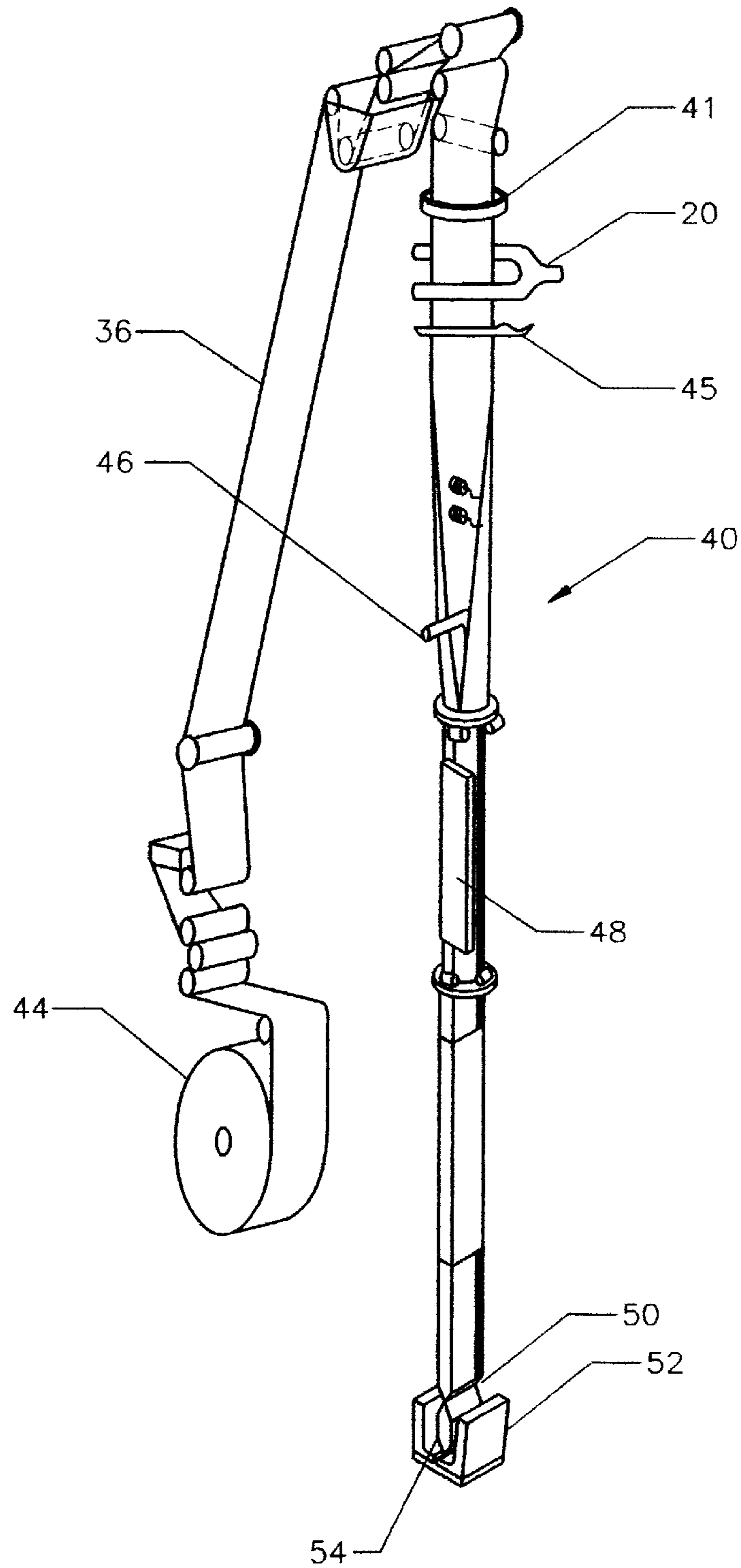

Fig. 2

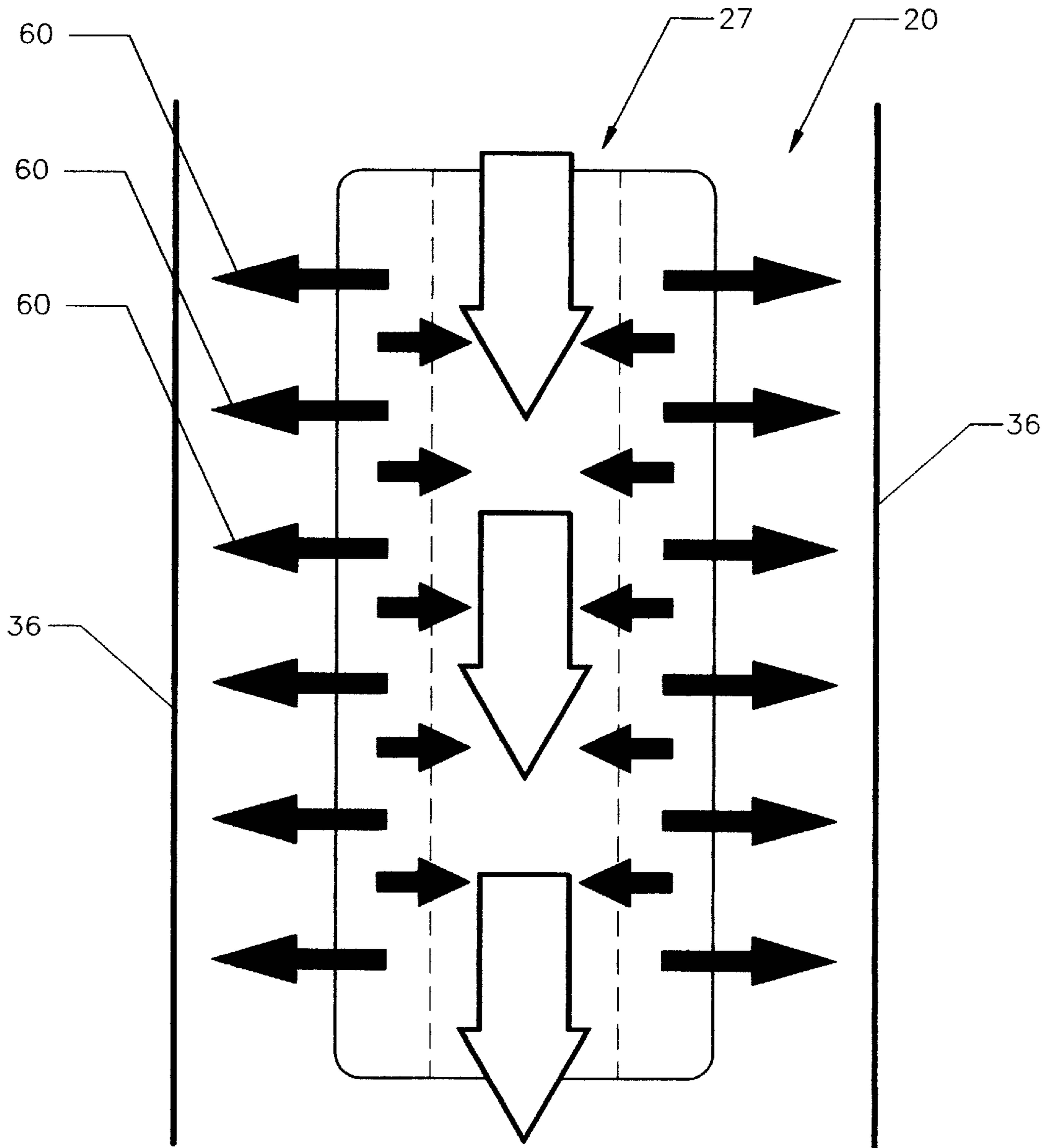

Fig. 3

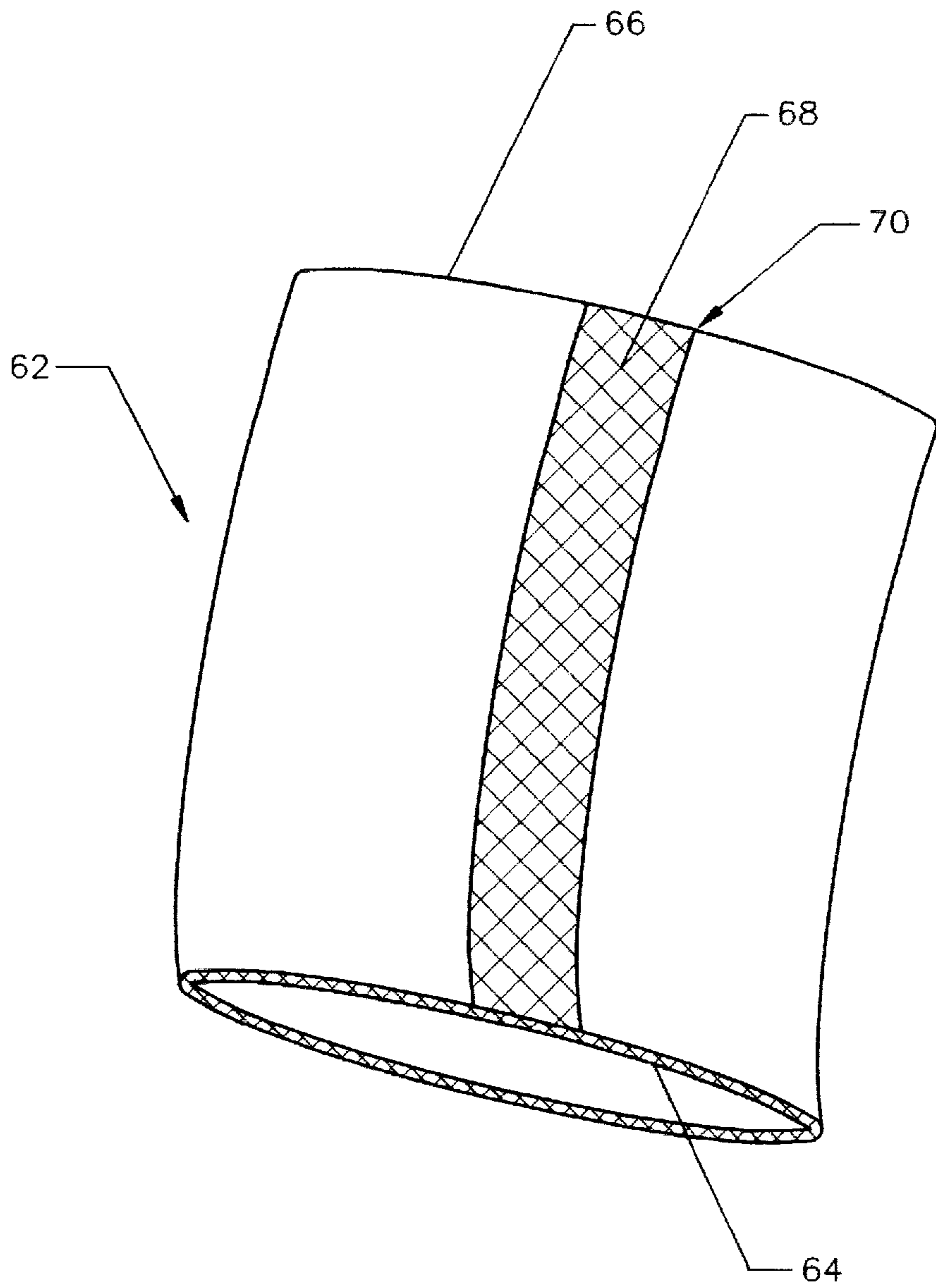

Fig. 4

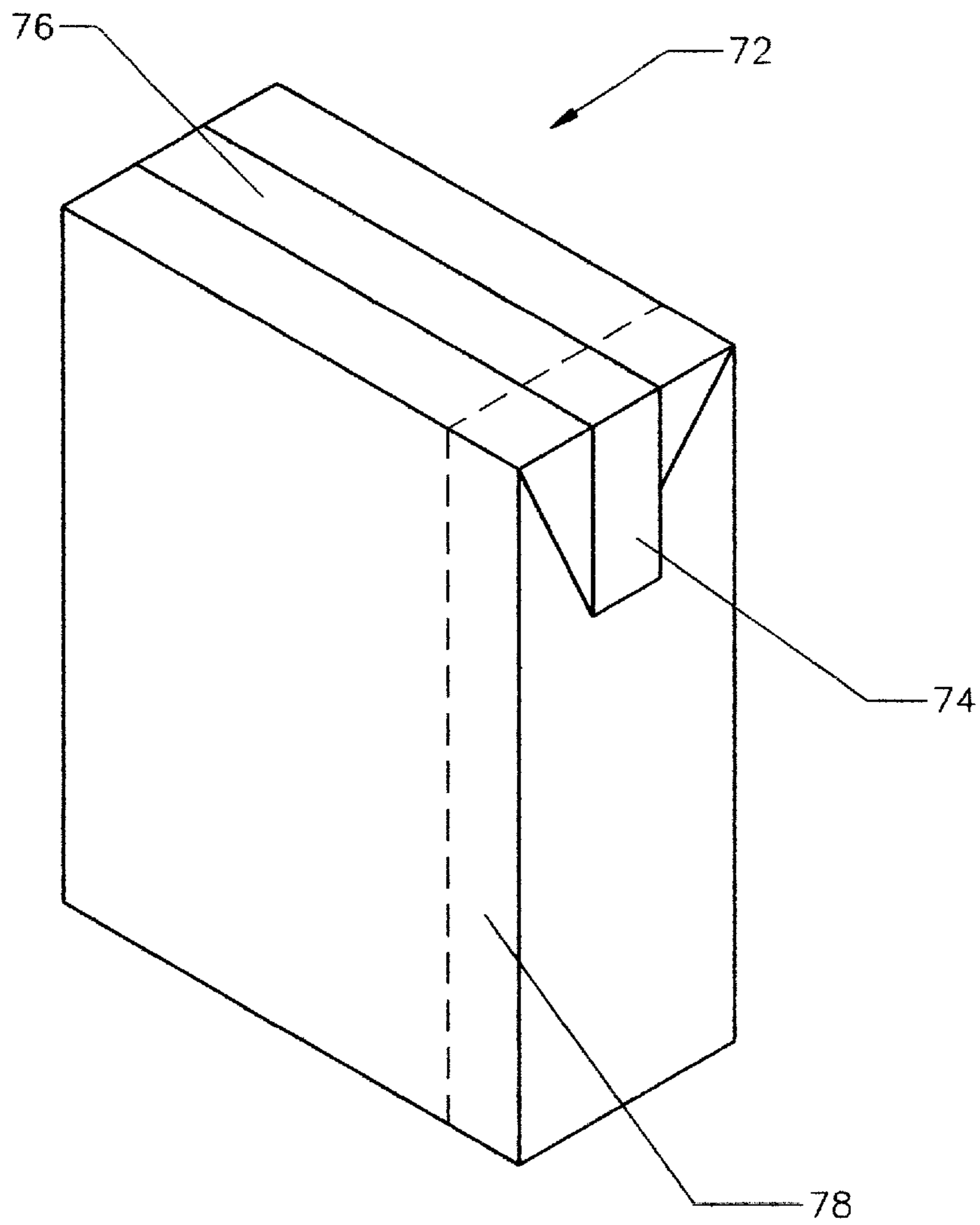

Fig. 5

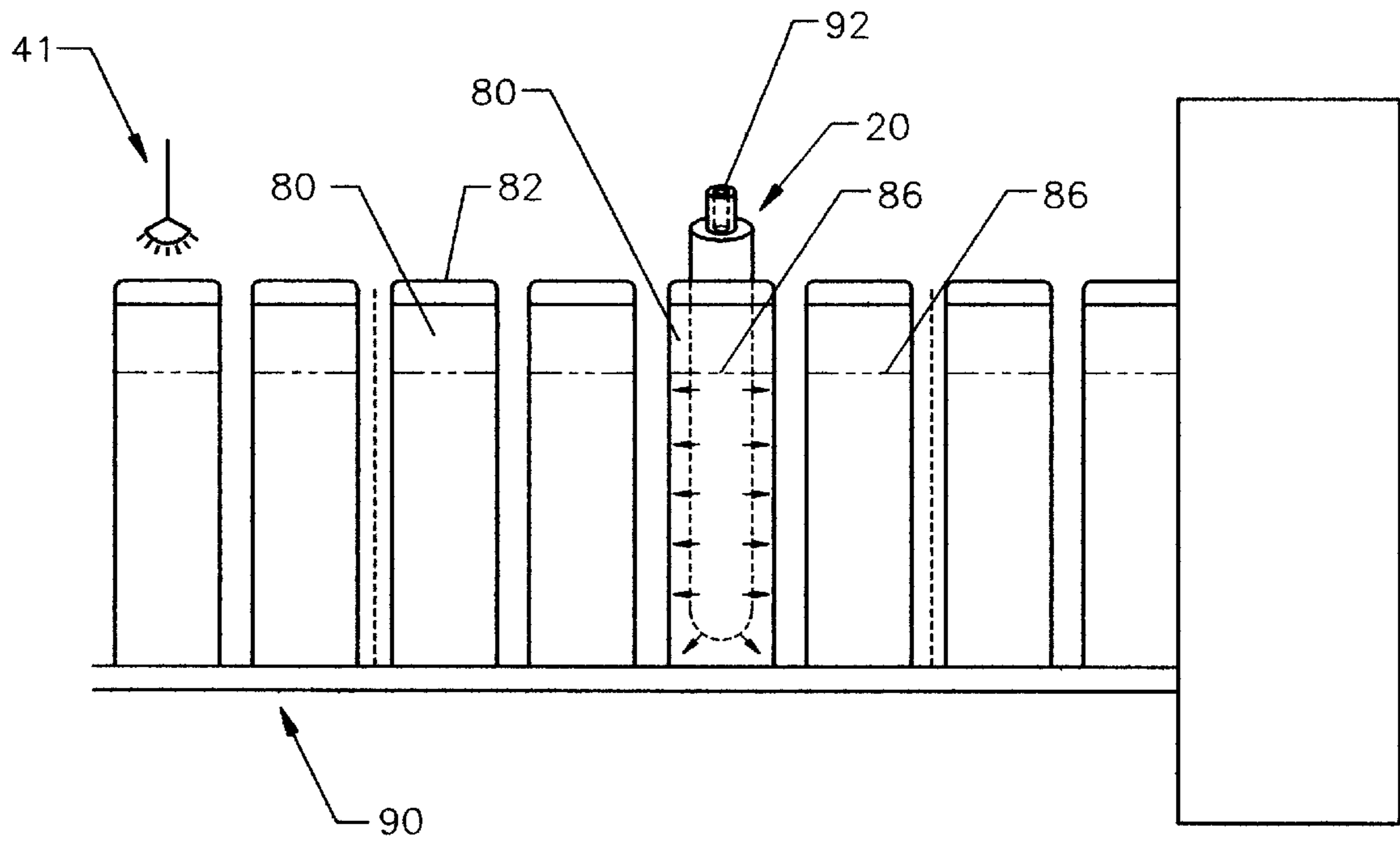

Fig. 6

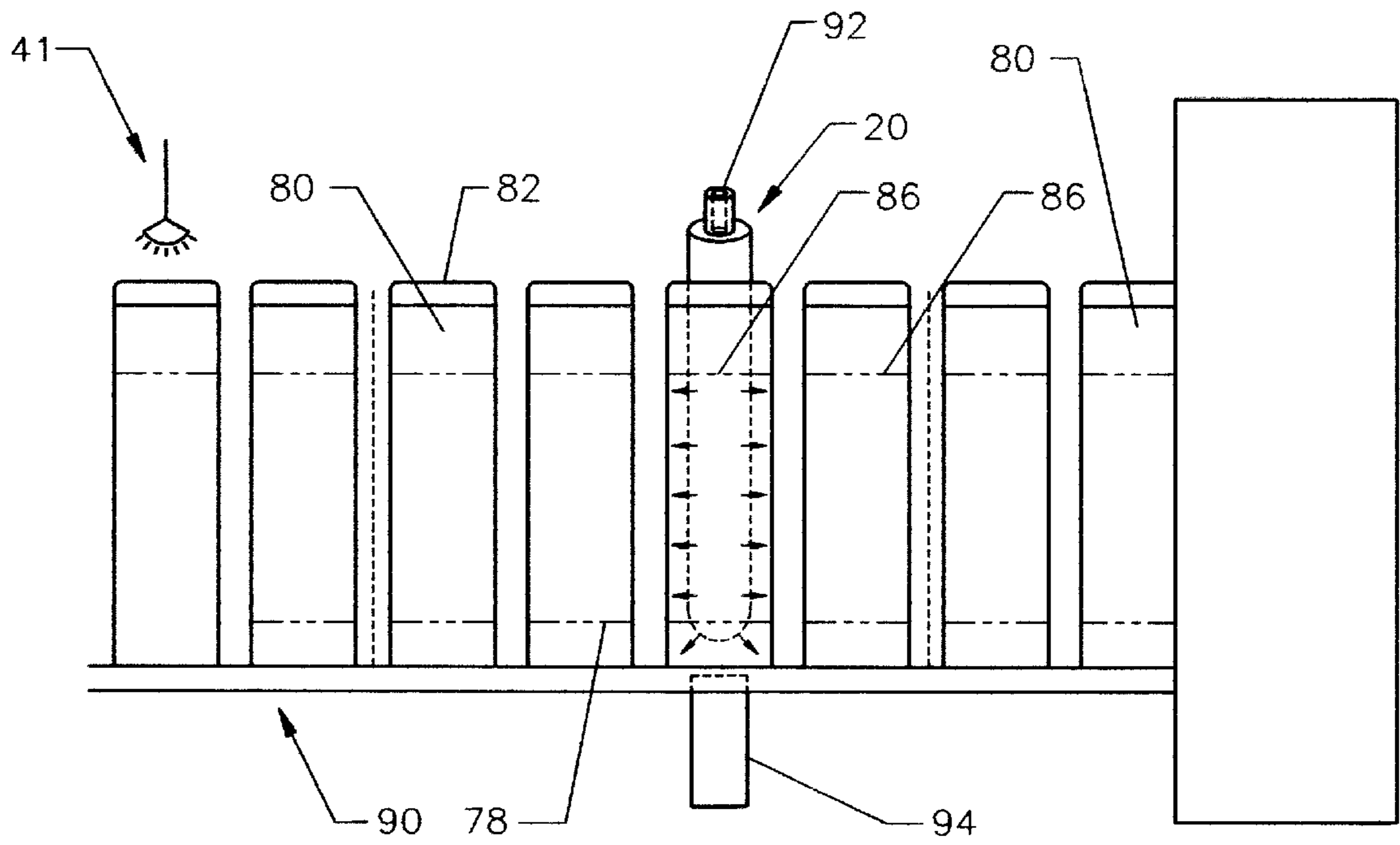

Fig. 7

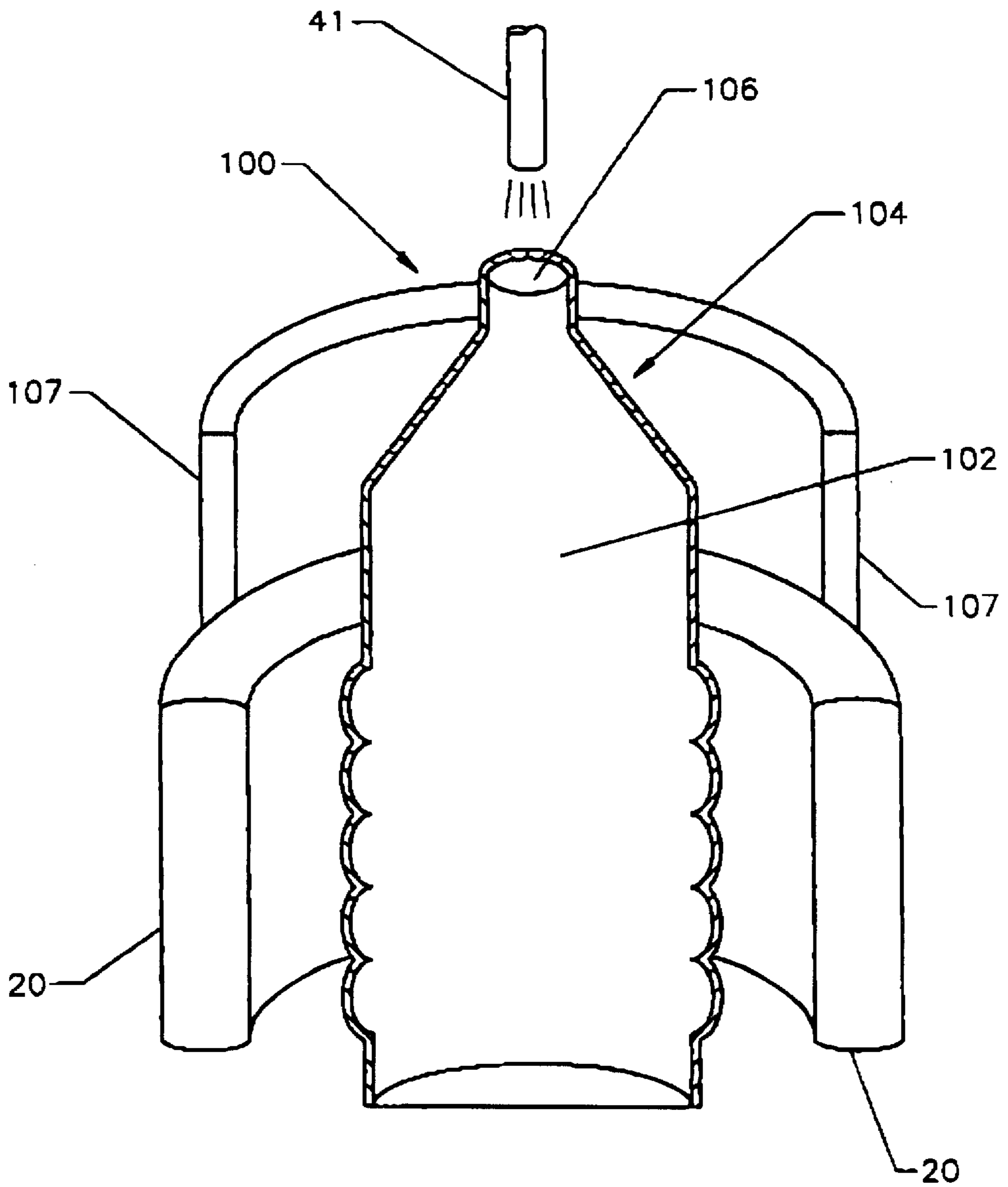

Fig. 8

METHOD AND APPARATUS FOR STERILIZING PACKAGING

TECHNICAL FIELD

This is a continuation-in-part of copending application Ser. No. 08/728,723 filed on Oct. 11, 1996.

The present invention relates to an apparatus and method for sterilizing packaging through irradiation with ultraviolet light. Specifically, the present invention relates to apparatus and method for sterilizing packaging through irradiation with an excimer ultraviolet lamp subsequent to subjecting the packing material to hydrogen peroxide.

BACKGROUND

It is well known that heat-sealable polymer materials may be fabricated into disposable containers for the packaging of liquids and other flowable materials. These containers are commonly used as consumer packaging for containing fruit juices and milk, and may have the form of a flexible pouch or parallelepiped container. The containers, once filled with a desired contents and sealed at a production center, are transported to a store for the ultimate distribution to the consumer. The consumer, with his or her subjective preferences, will have the choice of purchasing a flowable material contained in a flexible pouch or parallelepiped container, or in a more traditional package such as a plastic bottle, paper carton or metal can. In order to overcome the consumer's time-fortified preferences for the more traditional packaging, the disposable polymer containers must be able to provide the consumer with an assurance that the polymer container is safe (the contents) and is able to withstand the same handling treatment as the traditional package.

A polymer container as consumer packaging for flowable materials has numerous advantages over traditional packages such as glass bottles, paper cartons and high density polyethylene jugs. Compared to these traditional packages, a polymer pouch or parallelepiped container consumes less raw material, requires less space in a landfill, is recyclable, can be processed easily, requires less storage space, requires less energy for chilling because of increased heat transference, and can be readily incinerated. A polymer pouch is also reusable as a general purpose storage bag.

Flowable materials are usually packaged in a polymer pouches or parallelepiped containers through a vertical form, fill and seal machine. The operation of the form, fill and seal machine commences with the unwinding of a web of thermoplastic film which is then formed into a continuous tube in a tube forming section, by sealing the longitudinal edges of the film together to form a fin seal (the forming aspect of the machine). The tube thus formed is pulled vertically toward a filling station. The tube is then collapsed across a transverse cross-section of the tube, the position of the cross-section being at a sealing device. The sealing device makes a first transverse heat seal at the collapsed portion of the tube thereby creating an airtight seal across the tube. The sealing device generally comprises a pair of jaws which contain a heating element, the jaws closing upon the tube and the heating element heating to form the airtight seal. Subsequent to sealing the tube and prior to the opening of the jaws, a predetermined quantity of a desired contents is deposited into the tube to a predetermined level upward from the first transverse seal (the filling aspect of the machine). The tube is then moved downward to a predetermined position whereby the level of the desired contents is below the jaws of the sealing

device are again closed, thereby collapsing the tube at a second transverse section and creating a second transverse heat seal (the sealing aspect of the machine). During the second closing of the jaws, the sealing device clamps, seals and severs the tube transversely. A pouch filled with a flowable material is now ready for further transportation. For the parallelepiped container, subsequent to the severing of the tube, the container is further manipulated to form the parallelepiped container shape. Also, the parallelepiped container is formed into a substantially rectangular shape prior to the first transverse sealing. Thus, during the second closing, the sealing device has sealed the top of the filled pouch, severed this pouch from the rest of the tube, and sealed the bottom of the next-to-be filled pouch. An example of a form, fill and seal machine is the TETRA POUCH™, available from Tetra Pak, Inc., Chicago, Ill.

In the production of flowable materials in polymer containers, efficiency is measured by the speed in which such containers may be formed, filled and sealed. One aspect of the machines which may lead to decreased efficiency is the sterilization process for aseptic packaging. Presently, the sterilization process involves ultraviolet irradiation of the material prior to filling of the containers with a desired contents. The present ultraviolet sterilization apparatus involves a series of parallel mercury lamps, aluminum reflectors and a water cooling system contained within glass cover. These lamps operate at very high temperatures which have the possibility of damaging the material undergoing sterilization. The exposure time required for an effective kill greatly decreases the speed at which these machines may be operated at during production. An example of such a patent is Bachman, U.S. Pat. No. 4,121,107, for an Apparatus For Automatic Low-Bacteria To Aseptic Filling And Packing Of Foodstuffs which discloses an apparatus that exposes the packaging material to a set of ultraviolet light radiating mercury lamps for at least one second.

Another method for sterilizing packaging material is to utilize pulses of light to irradiate the material. An example of such a method is Dunn et al, U.S. Pat. No. 4,871,559, for Methods For Preservation Of Foodstuffs. Dunn et al discloses a method to use pulsed ultraviolet light originating from a flashlamp system to sterilize food packaging. Such a system generates high temperatures and also generates polychromatic radiation. Still other methods employ a beam of an ultraviolet or infrared laser diffracted into the interior of a partially-formed container to sterilize the container which has been coated with hydrogen peroxide.

The foregoing patents, although efficacious in the sterilization of packaging, are not the denouement of the problems of the packaging industry. There are still unresolved problems which compel the enlargement of inventions in the packaging industry. What is needed is a sterilization apparatus which may be integrated with current packaging machines, which is capable of effectively sterilizing packaging material without decreasing the operation speed of the machine, and which does not generate excessively high temperatures.

SUMMARY OF THE INVENTION

The present invention provides a sterilization apparatus to meet the unfulfilled needs of the packaging industry. The present provides for the effective sterilization of packaging material in an expedited manner while not generating excessively high temperatures.

One aspect of the invention is an apparatus for sterilizing transparent packaging material. The transparent packaging

material has an interior surface and an exterior surface. The apparatus comprises means for applying a ultraviolet radiation synergetic sterilant to the interior surface of the transparent packaging material and an ultraviolet radiation source oriented to directly irradiate the exterior surface with ultraviolet radiation. The interior surface is sterilized through transmission of the ultraviolet radiation through the transparent packaging material. The ultraviolet radiation source may be an excimer ultraviolet lamp. The ultraviolet radiation source may emit a substantially monochromatic wavelength. The excimer ultraviolet lamp may be composed of a quartz shell containing a gas selected from the group consisting of Ar₂, Kr₂, Xe₂, ArCl, KrCl, KrF and XeCl.

The transparent packaging material may be fabricated into a partially-formed container. The transparent packaging material is fabricated into a transparent bottle. The ultraviolet radiation synergetic sterilant may have a concentration range of between 1% and 55%. Alternatively, the ultraviolet radiation synergetic sterilant may have a concentration range of a between 2% to 16%. The transparent material may be sterilized at a rate of twenty meters per second. The transparent material may be fabricated into a pouch. The ultraviolet radiation source may provide uniform sterilization of the interior surface of the transparent material. The ultraviolet radiation synergetic sterilant may be hydrogen peroxide. The means for applying a ultraviolet radiation synergetic sterilant may be a sprayer which coats the interior surface with the sterilant. Alternatively, the means for applying a ultraviolet radiation synergetic sterilant may be a bath of the sterilant. The apparatus may also have a reflector for reflecting incident ultraviolet radiation toward the material. The reflector may have a parabolic shape.

Another aspect of the present invention is a method for sterilizing a transparent material. The transparent material having an interior surface and an exterior surface. The first step of the method is applying an ultraviolet radiation synergetic sterilant to the interior surface of the transparent packaging material. The next step is directly irradiating the exterior surface with ultraviolet radiation from an ultraviolet radiation source thereby sterilizing the interior surface through transmission of the ultraviolet radiation through the transparent packaging material. The final step is removing any excess sterilant from the interior surface of the transparent packaging material.

The method may further comprise the step of fabricating a transparent bottle from the sterilized transparent packaging material. Alternatively, the method may further comprise the step of fabricating a transparent pouch from the sterilized transparent packaging material. The ultraviolet radiation synergetic sterilant used in performing the method may be hydrogen peroxide.

There is illustrated in FIG. 8 a cross-sectional view of a transparent bottle which may be sterilized using the present invention.

Another aspect of the present invention is an apparatus for sterilizing a material undergoing fabrication into a container on a form, fill and seal machine. The container will be filled with a desired contents. The apparatus comprises means for applying a ultraviolet radiation synergetic sterilant to the material, an ultraviolet radiation source oriented to directly irradiate the material with ultraviolet radiation thereby sterilizing the material, and a wiper for removing excess sterilant from the material.

The ultraviolet radiation source may be an excimer ultraviolet lamp. The ultraviolet radiation source may emit a substantially monochromatic wavelength. The excimer

ultraviolet lamp may be composed of a quartz shell containing a gas selected from the group consisting of Ar₂, Kr₂, Xe₂, ArCl, KrCl, KrF and XeCl. The ultraviolet radiation synergetic sterilant may have a concentration range of between 1% and 55%. Alternatively, the ultraviolet radiation synergetic sterilant may have a concentration range of between 2% and 16%. The material may be sterilized at a rate of twenty meters per second. The material may be fabricated into a pouch. The ultraviolet radiation source may provide uniform sterilization of the material. The ultraviolet radiation synergetic sterilant may be hydrogen peroxide, hydrogen peroxide based sterilants, ozone or the like.

The means for applying a ultraviolet radiation synergetic sterilant may be a sprayer which coats the interior surface with the sterilant. Alternatively, the means for applying a ultraviolet radiation synergetic sterilant is a bath of the sterilant. The form, fill and seal machine may fabricate the material into a pouch. Alternatively, the form, fill and seal machine may fabricate the material into a parallelepiped container. The apparatus may be disposed along the form, fill and seal machine prior to a longitudinal sealing of the material. The material may be transparent. The ultraviolet radiation source may be U shape having two elongated projections merging at a base, the two elongated projections oriented substantially parallel to the material thereby allowing the material to pass between the two elongated projections for irradiation of the material.

Still another aspect of the present invention is a method for sterilizing a material undergoing fabrication into a container on a form, fill and seal machine. The first step of the method is applying an ultraviolet radiation synergetic sterilant to the material. The next step is directly irradiating the material with ultraviolet radiation from an ultraviolet radiation source thereby sterilizing the material. The final step of the method is removing any excess sterilant from the material.

The method may further comprise the step of forming the material into a pouch. Alternatively, the method may further comprise the step of forming the material into a parallelepiped container. The apparatus may be disposed along the form, fill and seal machine prior to a longitudinal sealing of the material. The method may further comprise the step of sealing the material longitudinally subsequent to the step of removing the excess sterilant. The method may still further comprise sealing the material transversely thereby partially forming the container subsequent to the step of sealing the material longitudinally. The method may still further comprise filling the partially formed container with the desired contents subsequent to the step of sealing the material transversely. The material may be transparent. The ultraviolet radiation source is shape having two elongated projections merging at a base, the two elongated projections oriented substantially parallel to the material thereby allowing the material to pass between the two elongated projections for irradiation of the material.

Having briefly described this invention, the above and further objects, features and advantages thereof will be recognized by those skilled in the pertinent art from the following detailed description of the invention when taken in conjunction with the accompanying drawings.

BRIEF DESCRIPTION OF THE DRAWINGS

Several features of the present invention are further described in connection with the accompanying drawings in which:

There is illustrated in FIG. 1 a top cross-section view of a preferred embodiment of an excimer ultraviolet lamp of the present invention.

There is illustrated in FIG. 2 a side view of an apparatus of the present invention integrated on a vertical form, fill and seal machine.

There is illustrated in FIG. 3 a cross-section side view of an apparatus of the present invention integrated on a vertical form, fill and seal machine.

There is illustrated in FIG. 4 an aseptic pouch sterilized in accordance with the present invention.

There is illustrated in FIG. 5 a parallelepiped container sterilized in accordance with the present invention.

There is illustrated in FIG. 6 a schematic view of one embodiment of an apparatus of the present invention integrated on a conveying system for gable top cartons.

There is illustrated in FIG. 7 a schematic view of an alternative embodiment of an apparatus of the present invention integrated on a conveying system for gable top cartons.

There is illustrated in FIG. 8 a cross-sectional view of a transparent bottle which may be sterilized using the present invention.

DETAILED DESCRIPTION OF THE PREFERRED EMBODIMENTS

The present invention applies to the sterilization of packaging materials undergoing fabrication to a container for flowable or pumpable materials. The present invention may also be utilized to fabricate an aseptic container. Such a container may take the form of a plastic bottle, a flexible pouch, a stand-up pouch, a parallelepiped container, a gabled top carton, or the like. An application of the present invention is with the fabrication of a container on a vertical form, fill and seal machine which is utilized to manufacture flexible pouches, stand-up pouches and parallelepiped containers. Another application of the present invention is with containers fabricated along a horizontal conveyance system such as that used for the fabrication of gabled top cartons. Still another application is with transparent materials such as used to fabricate bottles prior to the filling of the bottle with a desired contents. Although application of the present invention has been described in reference to fabrication and filling with the above-mentioned containers, those skilled in the pertinent art will recognize that the application of the present invention with the fabrication of other containers are within the scope of the present invention.

A preferred ultraviolet radiation source is an excimer lamp. However, the present invention may be practiced other ultraviolet lamps which emit a favorable ultraviolet radiation. These ultraviolet radiation sources may be mercury based lamps which emit a preferred wavelength.

Excimer Ultraviolet Technology

The present invention is based on excimer ultraviolet technology. Excimers are evanescent, electronically excited molecular complexes which exist only under unique conditions. The excimer is in an excited state as opposed to a ground state. In this excited state, elements such as the noble gases which are normally unreactive, are able to bind to one another or to other elements. Excimers usually disintegrate within a microsecond of formation and emit their binding energy as a photon as the two elements return to the ground state. For ultraviolet applications, the excimers formed from noble gas atoms or excimers formed from a noble gas and a halogen are of particular importance. Some of the more well known ultraviolet excimers include Ar₂, Kr₂, Xe₂, ArCl, KrCl, KrF and XeCl. These molecular complexes are ultraviolet excimers because the disintegration of the excimer,

excited dimer, results in an emission in the ultraviolet range of the electromagnetic spectrum. For example, the emission from KrCl has a wavelength of 222 nanometers ("nm"), the emission from KrF has a wavelength of 248 nanometers, the emission from Xe₂ has a wavelength of 172 nm, and the emission from XeCl has a wavelength of 308 nm. Although several ultraviolet excimers have been mentioned in reference to the present invention, those skilled in the pertinent art will recognize that other ultraviolet excimers may be employed in practicing the present invention without departing from the scope of the present invention.

An example of the excimer process for xenon is as follows. First, a xenon atom in the ground state is excited by interaction with an electron to an excited state. Next, this excited xenon atom reacts with a ground state xenon atom to form an excimer complex. Within a microsecond after formation, the xenon atoms dissociate to two ground state xenon atoms and doing so emit an ultraviolet photon.

The present invention may involve an excimer ultraviolet lamp in which a gas capable of forming excimers is hermetically sealed within a quartz glass shell. The gas may be a noble gas or a mixture of noble gas and a halogen. Electrons are generated by electrodes located outside of the shell and separated by a discharge gap. In one embodiment, the excimer ultraviolet lamp is cylindrical in shape having an aperture therethrough the center. In this embodiment, one electrode is juxtaposed to the exterior surface of the ultraviolet lamp while the second electrode is juxtaposed on the interior surface of the cylinder of the ultraviolet lamp. In another embodiment, the lamp is U-shaped.

There is illustrated in FIG. 1 a top cross-section view of a preferred embodiment of an excimer ultraviolet lamp of the present invention. As shown in FIG. 1, an excimer ultraviolet lamp is generally designated 20. The excimer ultraviolet lamp 20 is generally comprised of a U shaped shell 22 having a first elongated projection 24 and a second elongated projection 26 which merge at a base 28. There is sealed within the shell 22 a gas which is reacted to form excimers. The gas is electrically excited by an alternating voltage which causes a current flow in the discharge gap established between the inner electrode 30 and the outer electrode 32, not shown. The ultraviolet radiation generated by the excimers is generally directed outward from the shell 22 as designated by arrows 34, toward a material 36 to be irradiated.

The excimer ultraviolet lamp 20 of the present invention operates at a significantly lower temperatures than traditional mercury based ultraviolet lamps. However, the excimer ultraviolet lamp 20 of the present invention still requires cooling to prevent overheating of the lamp 20 and whatever materials are being sterilized by the lamp 20. To that end, a cooling fluid flows through passageways 38 on the exterior of the lamp 20 thereby removing heat from the excimer ultraviolet lamp 20. Alternatively, the passageways 38 may be located inside of the lamp 20. The cooling fluid is maintained at a predetermined temperature which is below the operating temperature of the excimer ultraviolet lamp 20 in order for the cooling fluid to act as a heat sink to remove heat from the lamp 20.

There is illustrated in FIG. 2 a side view of an apparatus of the present invention integrated on a vertical form, fill and seal machine. As shown in FIG. 2, the excimer ultraviolet lamp 20 is integrated on a vertical form, fill and seal machine generally designated 40. A means for applying a ultraviolet radiation synergetic sterilant is generally designated 41. The means 41 for applying the sterilant may be a sprayer, a bath

of the sterilant, or the like. A material **36**, undergoing fabrication to a container shape and originating from a coil of material **44**, passes through the means **41** to the lamp **20** and to a wiper **45** for removing any excess sterilant. On the form, fill and seal machine **40** is a filling pipe **46** which provides for the flow of a desired contents into a partially formed container. The filling pipe **46** is attached to a source of the desired contents on one end, and open on the other end for distribution of the desired contents into a partially formed container. Downstream from the filling pipe **46** is a longitudinal sealer **38**. The longitudinal sealer **48** seals the material **36** longitudinally thereby forming an enclosed tubular material. Subsequent to the longitudinal sealer **48** is the transverse sealer **50** which seals the material transversally prior to filling with a desired contents. At the same time the bottom of one container is being sealed, the top of another container is being sealed. The filled and sealed containers are cut from the rest of the material **36** by a cutting jaw **52**. Subsequent to the cutting jaw **52**, the newly formed container **54** may be further manipulated into a parallelepiped container, a stand-up pouch, or the like.

As the material **36** passes by the means for applying a sterilant **41**, the sterilant is applied to either one surface or both surfaces of the material **36**. Next as the material **36** passes through the excimer ultraviolet lamp **20**, the material **36** is sterilized by the ultraviolet radiation which is generated at a substantially monochromatic wavelength by the excimer ultraviolet lamp **20** as described above. The material **36** may be sterilized at a preferred rate of twenty centimeters per second. However, the form, fill and seal machine **40** may be operated at various rates depending on the material **36**. The sterilant may be hydrogen peroxide, ozone or the like. The concentration of sterilant would correspond to the needs of the material **32** in relation to the sterilization by the excimer ultraviolet lamp **20**. A preferred sterilant is hydrogen peroxide having at most a concentration of 16%. A further explanation of the use of the sterilant and ultraviolet radiation is explained below. A preferred gas for the excimer ultraviolet lamp **20** is KrCl which emits a wavelength of 222 nm. The KrCl gas excimer ultraviolet lamp **20** is utilized with a sterilant.

There is illustrated in FIG. **3** a cross-section side view of an alternative apparatus of the excimer lamp of the present invention integrated on a vertical form, fill and seal machine. As shown in FIG. **3**, this embodiment of the excimer ultraviolet lamp **20** is generally cylindrical in shape having a cylindrical central aperture **27** in which a desired contents to be packaged flows therethrough. The desired contents, which is to be packaged in the container fabricated on the form, fill and seal machine, is the cooling fluid which acts as a heat sink to remove heat from the lamp **20** as the desired contents flows through the central aperture **27**.

The placement of the apparatus of the present invention on a vertical form, fill and seal machine provides for the sterilization of a material **36** as it undergoes fabrication into a container. In this embodiment, the lamp **20** is placed downstream of the longitudinal sealing **48** and upstream from the transverse sealing **50**. The material **36** encompasses the lamp **20** as the material **36** is pulled downward for a first transverse sealing, a filling with the desired contents and then a second transverse sealing which also cuts the filled container from the other material **36** on the machine **40**. However, those skilled in the pertinent art will recognize that the apparatus of the present invention may be placed at other locations on the form, fill and seal machine without departing from the scope of the present invention.

As the material **36** is pulled downward, ultraviolet radiation sterilizes the soon to be interior of a container as

indicated by the radiation arrows **60**. The cylindrical shape of this embodiment of the excimer ultraviolet lamp **20** provides for the substantial irradiation of the material **36** as it is pulled downward pass the lamp **20**. In this manner, the material is sterilized within milliseconds thereby allowing for an accelerated operation of the form, fill and seal machine **40**.

Pouch Fabrication

The present invention encompasses various packaging for flowable materials. A preferred packaging is a flexible pouch for flowable materials. An example of such a pouch is illustrated in FIG. **4**. The pouch of FIG. **4** may be fabricated on a vertical form fill and seal ("VFFS") machine as previously described. A pouch embodying one aspect of the present invention is generally designated **62**. The pouch **62** has a first transverse seal **64**, a second transverse seal **66**, a longitudinal seal **68**, and an unsealed longitudinal overlap **70**. Fabrication of the pouch **62** commences with a film being fed into a VFFS machine, as described in FIG. **2**, whereby it is converted into a tubular form. The film is converted to the tubular form by sealing the longitudinal edges of the film together. Prior to making the longitudinal seal **68**, the film is sterilized by apparatus of the present invention as described in reference to FIG. **1**. The sealing may be accomplished either by overlapping the film and sealing the film using an inside/outside seal, or by film sealing the film using an inside/inside seal. An example of a inside/outside seal is illustrated in FIG. **4** where longitudinal seal **68** overlaps the inside surface of a film with the outside surface of the film thereby creating longitudinal seal **68** and the unsealed overlap **70**.

The first transverse seal **64** is formed by a sealing bar which transversely seals the bottom of pouch **62**. Then, a flowable material such as fruit juice is longitudinally added to the pouch **62**. The sealing bar then seals the top end of the pouch **62** thereby creating the second transverse seal **66**. The sealing bar also detaches pouch **62** from the tubular film by burning through the film or by cutting through the film. An example of such a sealing bar is disclosed in Reil, U.S. Pat. No. 3,738,080, for a Packing Machine. The capacity of pouch **62** may vary from 10 milliliters to 10 liters. The present invention enables a VFFS machine to operate at a higher capacity while producing aseptic pouches. Although the present invention has been described in reference to a VFFS, those skilled in the art will recognize that other packaging machines, such as a horizontal form, fill and seal machine, without departing from the scope of the present invention.

Parallelepiped Container Fabrication

Fabrication of a parallelepiped container is similar to that of a flexible pouch. Both containers are fabricated on a vertical form, fill and seal machine from a polymer material. However, there are variations in the fabrication process and the material. The epitome of parallelepiped containers is the TETRA BRIK® which may be fabricated in a method disclosed in Niske, U.S. Pat. No. 4,848,063 for a Method Of Manufacturing Packaging Container which is hereby incorporated by reference in its entirety.

There is illustrated in FIG. **5** a parallelepiped container sterilized in accordance with the present invention. As shown in FIG. **5**, the parallelepiped container is generally designated **72**. The parallelepiped container **72** has a triangular flap forming panel **74**, a transverse seal tab forming panel **76** and a longitudinal seal flap **78**. In a preferred

embodiment, the longitudinal seal creating the longitudinal seal flap **78** is made subsequent to sterilization with the excimer ultraviolet lamp **20** on a form, fill and seal machine. Also, subsequent to sterilization, the first transverse seal is made, the container **72** is filled, and a second transverse seal is made thereby creating the transverse seal tab forming panel **76**. The container **72** is further manipulated to form the familiar parallelepiped shape.

Gable Top Carton Sterilization

Unlike the previously discussed containers, the gable top carton is not fabricated on vertical form, fill and seal machine. However, similar to the other containers, the gable top carton has a tubular form, albeit a square tubular form, which may be sterilized using the present invention. Similar to the other containers, the excimer ultraviolet lamp **20** may be disposed within the gable top carton thereby sterilizing the interior of the carton with ultraviolet radiation. Alternatively, an excimer ultraviolet may be substituted for the ultraviolet lamp disclosed in copending application Ser. No. 08/472,567 filed on Jun. 7, 1995 which is hereby incorporated by reference.

There is illustrated in FIG. **6** a schematic view of one embodiment of an apparatus of the present invention integrated on a conveying system for gable top cartons. There is illustrated in FIG. **7** a schematic view of an alternative embodiment of an apparatus of the present invention integrated on a conveying system for gable top cartons. As shown in FIGS. **6** and **7**, a series of partially-formed cartons **80** are conveyed along a conveyor system **90**. Each of the cartons **80** are erected upright having an open top **82**, a top fin **84**, a top score line **86** and a bottom score line **88**. A means for applying a sterilant **41** is disposed along the conveyor system **90**. A sterilant such as hydrogen peroxide, ozone or peracid is sprayed into the cartons **80**. Then, the ultraviolet lamp **20** is placed within the interior of the carton **80** through the open top **82**.

There is in flow communication with the central aperture **27** of the ultraviolet lamp **20** a cooling fluid source pipe **92** at a top end of the central aperture **27**, and in the embodiment shown in FIG. **7**, a discharge pipe **94** on the bottom end of the central aperture **27**. The cooling fluid source pipe **92** dispenses a cooling fluid to the ultraviolet lamp **20**. In the embodiment shown in FIG. **6**, the cooling fluid flows down the sides of the central aperture **27** removing heat from the ultraviolet lamp **20**. Then the cooling fluid flows upward through an internal discharge pipe **96**, not shown, disposed within the cooling fluid source pipe **92**. The cooling fluid flows upward through the internal discharge pipe **96** by a vacuum means. In this embodiment, the bottom of the carton **80** may be sealed closed for filling with a desired contents.

In the embodiment shown in FIG. **6**, the cooling fluid flows from the cooling fluid source pipe **92**, through the central aperture **27** and into the discharge pipe **94**. In this embodiment, the bottom of the carton **80** is open allowing for the connection between the discharge pipe **94** and the central aperture **27** of the ultraviolet lamp **20**. In both FIGS. **6** and **7**, the score lines **86** and **88** designate where the carton **80** is folded to form the familiar gable top carton shape. The fin **84** is where the sides of the carton **80** are sealed together. In either embodiment shown in FIGS. **6** and **7**, substantially all of the interior of each carton **80** is sterilized by the ultraviolet radiation generated by the excimer ultraviolet lamp **20**.

There is illustrated in FIG. **8** a cross-sectional view of a transparent bottle which may be sterilized using the present invention. As shown in FIG. **8**, the bottle **100** has an interior surface **102** and an exterior surface **104**. The bottle **100** also has an opening **106**. The means for applying a sterilant **41**

applies a sterilant to the interior surface **102** of the bottle **100**. Then, from the exterior, the ultraviolet lamp **20** irradiates the exterior surface **104** which permits the transmission of the radiation to the interior surface **102** thereby sterilizing the interior of the bottle **100**.

Alternatively, a transparent preform sheet for the bottle **100** may be sterilized in a similar fashion by applying a sterilant to the interior surface **102** and irradiating the exterior surface **104**.

The present invention will be described in the following examples which will further demonstrated the efficacy of the novel apparatus and method for sterilizing packaging material, however, the scope of the present invention is not to be limited by these examples.

EXAMPLE ONE

An investigation was performed on the microbicidal effect of H₂O₂ and UV (254 nm and 222 nm) combination treatment on spores for sterilization of packaging material.

In the first phase a UV lamp (a **3** mW non-monochromatic source with a peak at 254 nm) was positioned such that it was flat on the surface of the hood. The packaging material was a silicon oxide ("SiOx")-polyethylene polymer. The percent transmission of the material to various wavelengths are given in Appendix 1. A mount for the sample was constructed by cutting two square holes in a piece of cardboard, a 5x5 cm² hole inside of an 8x8 cm² hole. The 5x5 cm² hole served as the window where the sample was placed such that the UV light could penetrate the sample. The 8x8 cm² cut allowed the sample mount to be removed and replaced without changing the position of the mount over the UV lamp. The mount was held in place directly over the UV lamp using two burette stands and clamps. The height of the mount was determined using the UV meter, such that the UV intensity transmitted through the plastic material at the set height was 0.3 mW.

Polyethylene coated with SiOx on one side, a UV transparent plastic material was used for the experiment. The material was cut into 8x8 cm² squares and labeled according to the treatment it was to receive. Ten replications of each treatment was performed.

Bacillus subtilis A (BsA) spores was used in the experiments. The spores were diluted to 1x10^{7.3} cfu/mL by pipetting 1.0 mL of 1x10^{8.3} cfu/mL into 9.0 mL of phosphate buffer solution. The spores were then labeled and stored in the refrigerator. The concentration of BsA spores was checked by pour plating the following dilution's on standard plate count agar (PCA): -6, -7, -8, -6 hs, -7 hs, -8 hs, where hs=heat shock. The procedure followed is described. The original spore suspension in the eppendorf vial was vortexed to mix and suspend the spores and then the spores were diluted as shown in Table 1.

TABLE 1

Dilution scheme and procedure used for checking the spore load in the original vial.	
Dilution	Dilution Procedure
-3	0.1 mL -1 dilution + 9.9 mL phosphate buffer
-5	0.1 mL -3 dilution + 9.9 mL phosphate buffer
-7	0.1 mL -5 dilution + 9.9 mL phosphate buffer

Then, 5 mL of the -5 dilution and 5 mL of the -7 dilution was pipetted into sterile (autoclaved) screw cap test tubes and heat shocked for 10 minutes at 80° C. After the tubes cooled, the plating was done. The plating scheme and procedure are shown in Table 2.

TABLE 2

Plating scheme and procedure used for plating.	
Dilution Plated	Plating Procedure
-6	Plate 0.1 mL of -5 dilution
-6 hs	Plate 0.1 mL of -5 hs dilution
-7	Plate 1.0 mL of -7 dilution
-7 hs	Plate 1.0 mL of -7 hs dilution
-8	Plate 0.1 mL of -7 dilution
-8 hs	Plate 0.1 mL of -7 hs dilution

Finally, the plates were incubated at 32° C. for 48 hours and then counted. The plate count obtained was found to be in the expected range.

The protocol for the experiments is as follows:

- The spores were applied onto the plastic using the 'swab out' method. After taping the plastic material, 10 mL of $1 \times 10^{7.3}$ spores/mL was pipetted onto the center of the 5×5 cm² plastic square on the polyethylene side so as to get $1 \times 10^{5.3}$ cfu/mL per 25 cm². A sterile cotton swab was soaked in sterile phosphate buffer solution and twisted against the side of the test tube to remove excess liquid. This swab was then used to spread the 10 mL of spores uniformly over the 25 cm² area of plastic.
- Immediately after application of the spores, H₂O₂ was sprayed onto the spores. The concentrations of H₂O₂ used were 1%, 2%, 4% and 8%. A generic plastic spray bottle was used to spray the H₂O₂ with the nozzle set so as to spray the finest mist. The weight of H₂O₂ applied was checked a few times to ascertain that the amount of H₂O₂ applied was approximately constant. The time between application of the H₂O₂ and recovery of the swabs was a constant 3 minutes, including UV treatment time. A stopwatch was used to monitor this time.
- The mounted sample was then placed directly above the UV lamp. The UV lamp and stopwatch were started simultaneously, and the UV lamp was switched off at the time specified for the desired dosage (Table 3).

TABLE 3

UV treatment variables		
Dose (mW-s)	Intensity* (mW)	Time (s)
0	0.3	0
3	0.3	10
6	0.3	20
9	0.3	30
12	0.3	40
15	0.3	50

*Note: The intensity is the UV intensity which is transmitted through the plastic material at a set height above the UV lamp as determined by use of the UV meter.

- Three minutes after spraying the H₂O₂, the spores were recovered. The recovery procedure is as follows. A dry swab was vigorously rubbed up and down and then side to side in the 5×5 cm² area of application. This swab was then broken off and placed in 3 mL of phosphate buffer. The process was repeated using a second dry swab which was also placed in the same test tube. Just after recovery, a sterile syringe was used to deliver a drop of catalase to the 3 mL of phosphate buffer used in order to degrade the H₂O₂. The microbial contamination of catalase was found to be low and therefore no further steps were taken to sterilize it. The test tube was then vortexed to release the spores from the swabs and to mix the catalase and H₂O₂. After vortexing, the tubes were kept undisturbed for at least an hour before diluting and plating.

- For samples receiving only UV treatment: Immediately after UV treatment, the spores were recovered. The recovery procedure is as follows. A sterile swab was soaked in sterile phosphate buffer solution and the excess solution was pressed out by twisting the swab against the side of the test tube. The wet swab was vigorously rubbed up and down and then side to side in the 5×5 cm² area of application. This swab was then broken off and placed in 3 mL of phosphate buffer. The process was repeated using a dry swab which was also placed in the same test tube. The test tube was vortexed to release the spores from the swabs. After vortexing, the tubes were kept undisturbed for at least an hour before diluting and plating.

- The recovered spores were pour plated using total plate count agar (PCA). 0, -1, and -2 dilutions were plated. The -1 and -2 dilutions were made by diluting 0.5 mL from the zero sample into 4.5 mL of phosphate buffer and then pipetting 1 mL of this solution for the -1 dilution and 0.1 mL for the -2 dilution. One zero plate and duplicates of the -1 and -2 dilution plates were plated. Controls were made for the media, buffer, and hood.

- The plates were incubated at 32° C. for 48 hours.

The following controls were conducted along with the UV-H₂O₂ experiment described above:

- Positive control—The inoculated plastic did not receive UV or H₂O₂ treatment. This control was done to determine the recoverable spore count (initial load). Ten positive control samples were done each time spores were applied. The recovery procedure for the positive control was the same as that followed for the UV only treatment.

- Negative control—The plastic was not inoculated and it did not receive UV or H₂O₂ treatment. This control helped in determining the background microbial population on the plastic and contamination due to the methodology. Only a zero plate was plated for the negative controls—no dilutions were done. Ten negative control samples were done each time the spores were applied. The recovery procedure for the negative control was the same as that followed for the UV only treatment.

For phase 2, a monochromatic (222 nm wavelength) UV lamp with a surface intensity of 0.24 W per cm² was used (See Appendix 2 for lamp specifications). The lamp dimensions were 30×8 cm². A mount for the samples was constructed by cutting five holes (5×5 cm²) in a cardboard within a 30×8 cm² area. The mount was held in place, 40 cm over the UV lamp using burette stands and clamps. The plastic materials used were SiOx—polyethylene and 30 μ LDPE (See Appendix 1 for transmission rates).

The procedure for the preparation and application of the spores on the plastic material was the same as that followed in Phase 1. The H₂O₂ concentrations used were 2%, 4%, 8% and 16%. Samples were exposed for 5, 6, 8 and 10 seconds. For each time of exposure one set of samples received only UV treatment and another set received UV-Water combination treatment. One set of 30 μ LDPE samples were treated with 16% H₂O₂ alone. Ten replications of each treatment was performed. The five samples which received the UV treatment simultaneously were recovered by the procedure described earlier. Time from spraying the H₂O₂ onto the first sample to the recovery of the last (fifth) sample was found to be within 15 minutes in all cases. Positive and Negative controls were also used.

The data for phase 1 was not found to follow any definite pattern. However it was observed that the log reduction (LR) dips down at 2% H₂O₂ concentration for an UV intensity of 6 mW-s and higher. This trend is not noticed for the UV intensities of 0 mW-s (where the LR peaks at 2%) and for 3 mW-s (the LR curve is flat). Similarly, the LR at 8% H₂O₂

concentration, with varying intensities of UV radiation in all cases but one at 12 mW-s was found to be lower than the LR at 4% H₂O₂ concentration. This is surprising as the sporidical action of H₂O₂ has been found to increase with increasing concentrations. This may be due to the interaction between the UV radiation and H₂O₂. The UV lamp used was not monochromatic and therefore might have caused other effects that have not been taken into account.

Also, H₂O₂ has been found to be slow to inactivate spores at ambient temperatures being more effective at higher temperatures. The experiments were conducted at room temperature and this may have had an effect on the overall sporidical effectiveness of H₂O₂ and also in its interaction with the UV radiation.

For phase 2, the log reduction did not increase significantly with increase of UV exposure time. The results from the 16% H₂O₂ treatment alone show a log reduction of 1.52. This indicates that the combination treatment of UV and peroxide might be producing a lower log reduction than if the two treatments were carried out individually.

The water and UV combination treatment was found to be more effective than the UV treatment alone. However, in a number of experiments the water-UV treatment is seen to be more effective than the 2% peroxide-UV treatment. This may be due to the nature of interaction between UV and peroxide; and UV and water. If this proves to be the case, spraying of water in conjunction with the UV treatment could be a cost effective method for sterilizing packaging material.

The SiOx-polyethylene polymer has a lower percent transmission at 222 nm than the 30 μ LDPE polymer. However, the log reduction obtained with the SiOx polymer was found to be higher than the reduction obtained with the latter polymer for the same treatment. This may be due to the surface chemistry of the polymers and its influence in the application and recovery procedures.

All experiments were all carried out at a distance of 40 cm from the surface of the UV lamp. No significant increase in kill was observed with an increase in UV exposure time. This may be either due to the nature of UV-peroxide interactions or because a very small fraction (0.48 mW per cm²) of the total lamp power (0.24 W/cm²) is incident on the samples at a height of 40 cm.

APPENDIX 1

Wavelength (nm)	Percent Transmission
<u>SiOx - Polyethylene Polymer Transmission Data</u>	
200	32.87%
222	73.88%
250	85.86%
300	87.49%
<u>30μ LDPE Transmission Data</u>	
190	17.12%
222	88.45%
250	89.30%
350	90.44%

TABLE 4

<u>Results Summary of Phase 2 Experiments</u>				
Run 4: 4 sec	Run 5: 6 sec	Run 6: 6 sec	Run 7: 8 sec	Run 8: 10 sec
0.65	0.69	0.59	0.36	0.72
0.18	0.21	0.1	0.2	0.15

TABLE 4-continued

<u>Results Summary of Phase 2 Experiments</u>				
Run 4: 4 sec	Run 5: 6 sec	Run 6: 6 sec	Run 7: 8 sec	Run 8: 10 sec
1.05	0.89	0.67	0.8	0.8
0.18	0.1	0.12	0.1	0.16
—	—	0.73	0.63	0.85
—	—	0.17	0.11	0.1
—	—	0.81	0.86	0.99
—	—	0.18	0.09	0.15
—	—	1.06	0.78	1.54
—	—	0.38	0.09	0.17
—	1.83	1.76	1.57	2.32
—	0.13	0.16	0.31	0.3

From the foregoing it is believed that those skilled in the pertinent art will recognize the meritorious advancement of this invention and will readily understand that while the present invention has been described in association with a preferred embodiment thereof, and other embodiments illustrated in the accompanying drawings, numerous changes, modifications and substitutions of equivalents may be made therein without departing from the spirit and scope of this invention which is intended to be unlimited by the foregoing except as may appear in the following appended claims. Therefore, the embodiments of the invention in which an exclusive property or privilege is claimed are defined in the following appended claims.

We claim as our invention the following:

1. An apparatus for sterilizing the interior of a pre-formed transparent container, the pre-formed transparent container having an enclosed interior, an exterior surface and an opening for accessing the interior of the pre-formed transparent container, the apparatus comprising:

means for introducing a sterilant into the interior of the pre-formed transparent container, the sterilant selected from the group comprising ozone, peroxides and water; an excimer ultraviolet radiation source for irradiating the exterior surface of the pre-formed transparent container, the radiation transmitting through the exterior surface to irradiate the sterilant in the interior of the pre-formed transparent container, the excimer ultraviolet radiation having a substantially monochromatic wavelength below 254 nanometers.

2. The apparatus according to claim 1 wherein the pre-formed transparent container is a transparent bottle.

3. The apparatus according to claim 1 wherein the sterilant is hydrogen peroxide having a concentration of 1% to 55% hydrogen peroxide to water.

4. The apparatus according to claim 1 further comprising means for conveying a series of pre-formed transparent containers.

5. The apparatus according to claim 2 wherein the transparent bottle has a SiOx barrier, layer.

6. The apparatus according to claim 1 wherein the excimer ultraviolet radiation source comprises a quartz lamp containing a KrCl gas emitting ultraviolet radiation having a wavelength of 222 nanometers.

7. The apparatus according to claim 1 wherein the introducing means is a sprayer disposed above the opening of the pre-formed transparent container.

8. A method for sterilizing the interior of a pre-formed transparent container, the pre-formed transparent container having an enclosed interior, an exterior surface and an opening for accessing the interior of the pre-formed transparent container, the method comprising:

introducing a sterilant into the interior of the of the pre-formed transparent container, the sterilant selected from the group comprising ozone, peroxides and water; and

15

irradiating the exterior surface of the pre-formed transparent container with an excimer ultraviolet radiation source, the radiation transmitting through the exterior surface to irradiate the sterilant in the interior of the pre-formed transparent container, the excimer ultraviolet radiation having a substantially monochromatic wavelength below **254** nanometers.

9. The method according to claim **8** wherein the pre-formed transparent container is a transparent bottle.

10. The method according to claim **8** wherein the sterilant is hydrogen peroxide having a concentration of 1% to 55% hydrogen peroxide to water.

11. The method according to claim **9** wherein the transparent bottle has a SiO_x barrier layer.

12. The method according to claim **8** wherein the excimer ultraviolet radiation source comprises a quartz lamp containing a KrCl gas emitting ultraviolet radiation having a wavelength of 222 nanometers.

13. The method according to claim **8** wherein the introducing the sterilant and irradiating the exterior are performed simultaneously.

14. A method of sterilizing a transparent packaging material undergoing fabrication on a form, fill and seal packaging machine, the packaging machine having a continuous roll of transparent packaging material which is longitudinally sealed to form a tubular material, transversally sealed, filled with a flowable food product and then transversally sealed again, the transparent packaging material having an interior surface and an exterior surface and, the method comprising:

dispersing a sterilant onto the interior surface of the transparent packaging material subsequent to the transparent packaging material being unwound from the continuous roll on the form, fill and seal packaging

16

machine, the sterilant selected from the group comprising peroxides, ozone and water;

irradiating the exterior surface of the transparent packaging material with ultraviolet radiation from an excimer ultraviolet radiation source, the radiation having a substantially monochromatic wavelength less than 254 nanometers, the step of irradiating the exterior surface occurring approximately simultaneously with the step of dispersing a sterilant onto the interior surface of the transparent packaging;

removing any excess sterilant from the interior surface of the transparent packaging material subsequent to irradiating the exterior surface thereby providing a sterilized transparent packaging material for formation into a partially formed package;

filling the partially formed package with a flowable food product; and

sealing the filled partially formed package.

15. The method according to claim **14** wherein the sterilant is hydrogen peroxide having a concentration of 1% to 55% hydrogen peroxide to water.

16. The method according to claim **14** wherein the transparent packaging material has a SiO_x barrier layer.

17. The method according to claim **14** wherein the excimer ultraviolet radiation source comprises a quartz lamp containing a KrCl gas emitting ultraviolet radiation having a wavelength of 222 nanometers.

18. The method according to claim **14** wherein the transparent packaging material is formed into a flexible pouch.

19. The method according to claim **14** wherein the transparent packaging material is formed into a stand-up pouch.

* * * * *