



US005838379A

# United States Patent [19] Takayama

[11] Patent Number: **5,838,379**  
[45] Date of Patent: **Nov. 17, 1998**

[54] **IMAGE PROCESSING APPARATUS HAVING MEANS FOR CONTROLLING EXPOSURE USING AN ORTHOGONAL TRANSFORMATION COEFFICIENT**

[75] Inventor: **Makoto Takayama**, Yokohama, Japan

[73] Assignee: **Canon Kabushiki Kaisha**, Tokyo, Japan

[21] Appl. No.: **448,266**

[22] Filed: **May 23, 1995**

### Related U.S. Application Data

[62] Division of Ser. No. 881,866, May 12, 1992.

### [30] Foreign Application Priority Data

May 15, 1991	[JP]	Japan	3-109999
May 15, 1991	[JP]	Japan	3-110213
May 15, 1991	[JP]	Japan	3-110214
May 15, 1991	[JP]	Japan	3-110215
May 15, 1991	[JP]	Japan	3-110216
Jun. 20, 1991	[JP]	Japan	3-148437

[51] Int. Cl.<sup>6</sup> ..... **H04N 7/30**

[52] U.S. Cl. .... **348/403; 382/248**

[58] Field of Search ..... 348/231, 255, 348/257, 345, 363-365, 384, 390, 400, 403; 382/232, 248-250; H04N 7/133

### [56] References Cited

#### U.S. PATENT DOCUMENTS

5,016,107	5/1991	Sasson et al. .	
5,027,214	6/1991	Fujimori	348/231
5,032,927	7/1991	Watanabe et al.	358/335

5,045,925	9/1991	Saito .	
5,065,246	11/1991	Takemoto et al. .	
5,073,821	12/1991	Juri .	
5,105,278	4/1992	Takemoto .	
5,109,451	4/1992	Aono et al. .	
5,142,380	8/1992	Sakagami et al. .	
5,144,428	9/1992	Okuda et al. .	
5,144,450	9/1992	Kikuchi et al. .	
5,155,592	10/1992	Verbiest et al. .	
5,341,170	8/1994	Takemoto	348/354

### FOREIGN PATENT DOCUMENTS

0455434	11/1991	European Pat. Off.	H04N 5/21
0481768	4/1992	European Pat. Off.	H03M 7/30
2575886	7/1986	France	H05N 5/217
4033552	4/1991	Germany	H04N 1/415

### OTHER PUBLICATIONS

IEEE Transactions on Acoustics, Speech and Signal Processing, vol. 37, No. 11, Nov. 1989, New York, pp. 1743-1749, "Adaptive Cosine Transform Coding of Images in Perceptual Domain."

Primary Examiner—Richard Lee

Attorney, Agent, or Firm—Fitzpatrick, Cella, Harper & Scinto

### [57] ABSTRACT

An image processing apparatus includes input structure for inputting orthogonal-transformed image data. Arithmetic circuitry is provided for adding a predetermined value to transformation coefficients of the orthogonal-transformed image data input by the input structure. Structure is also provided for image processing data input from the arithmetic circuitry.

12 Claims, 22 Drawing Sheets

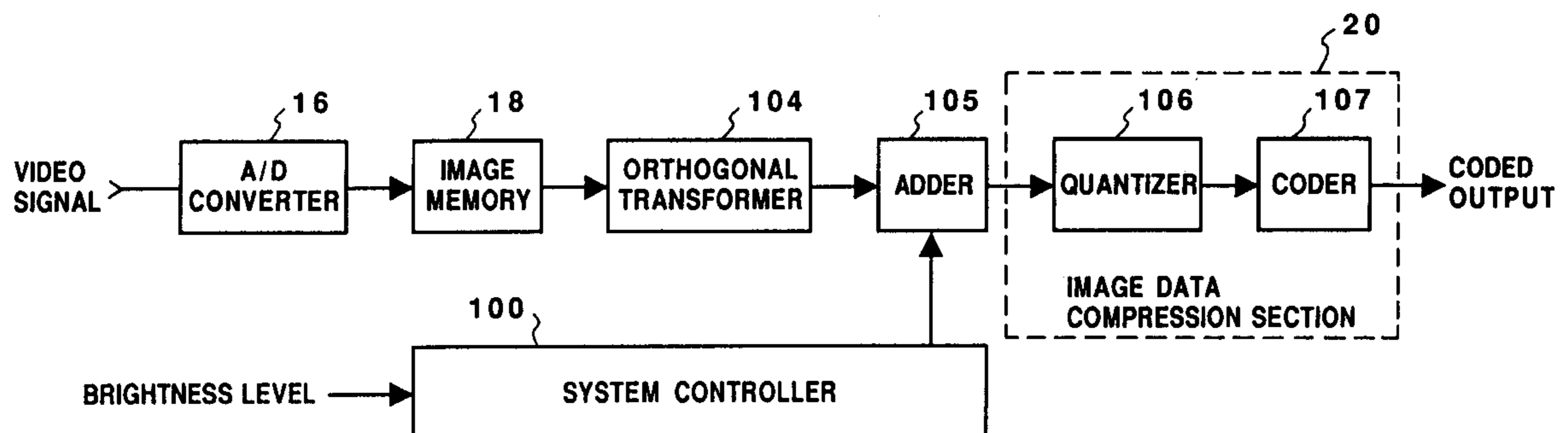

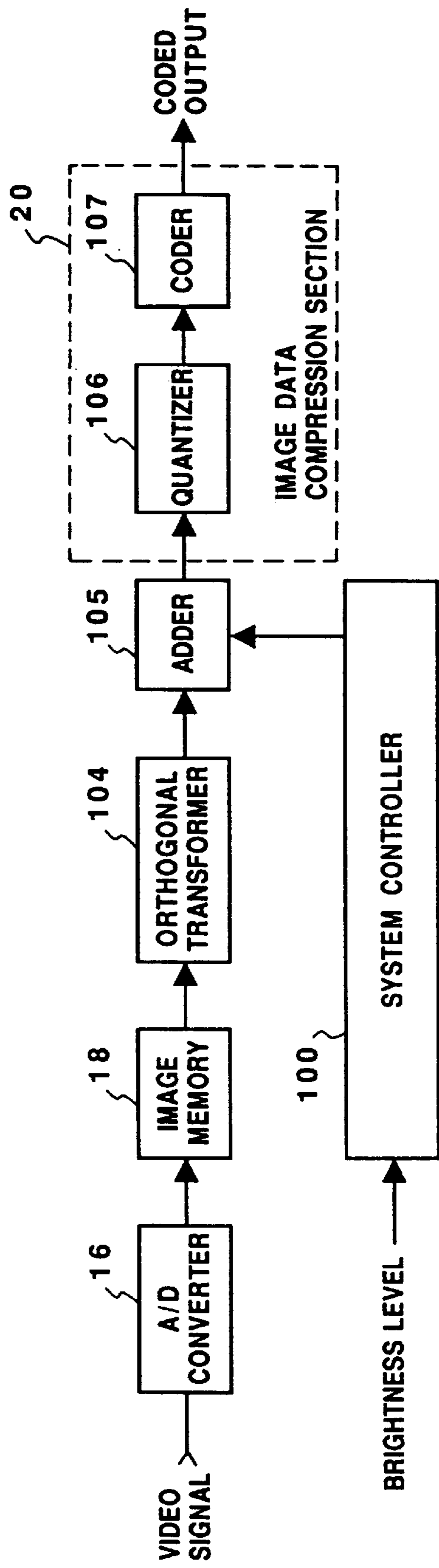
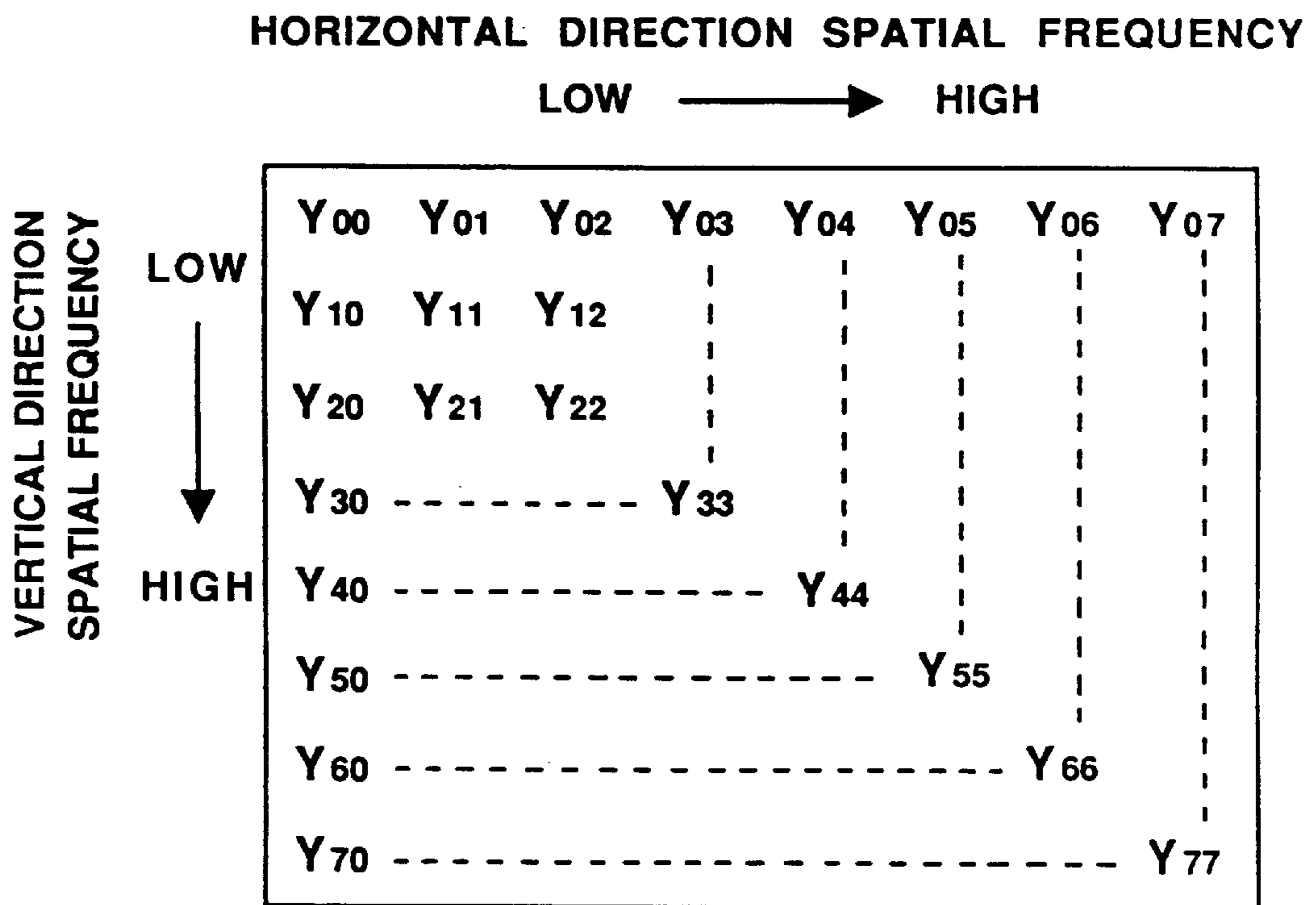

FIG. 1



**FIG. 2**

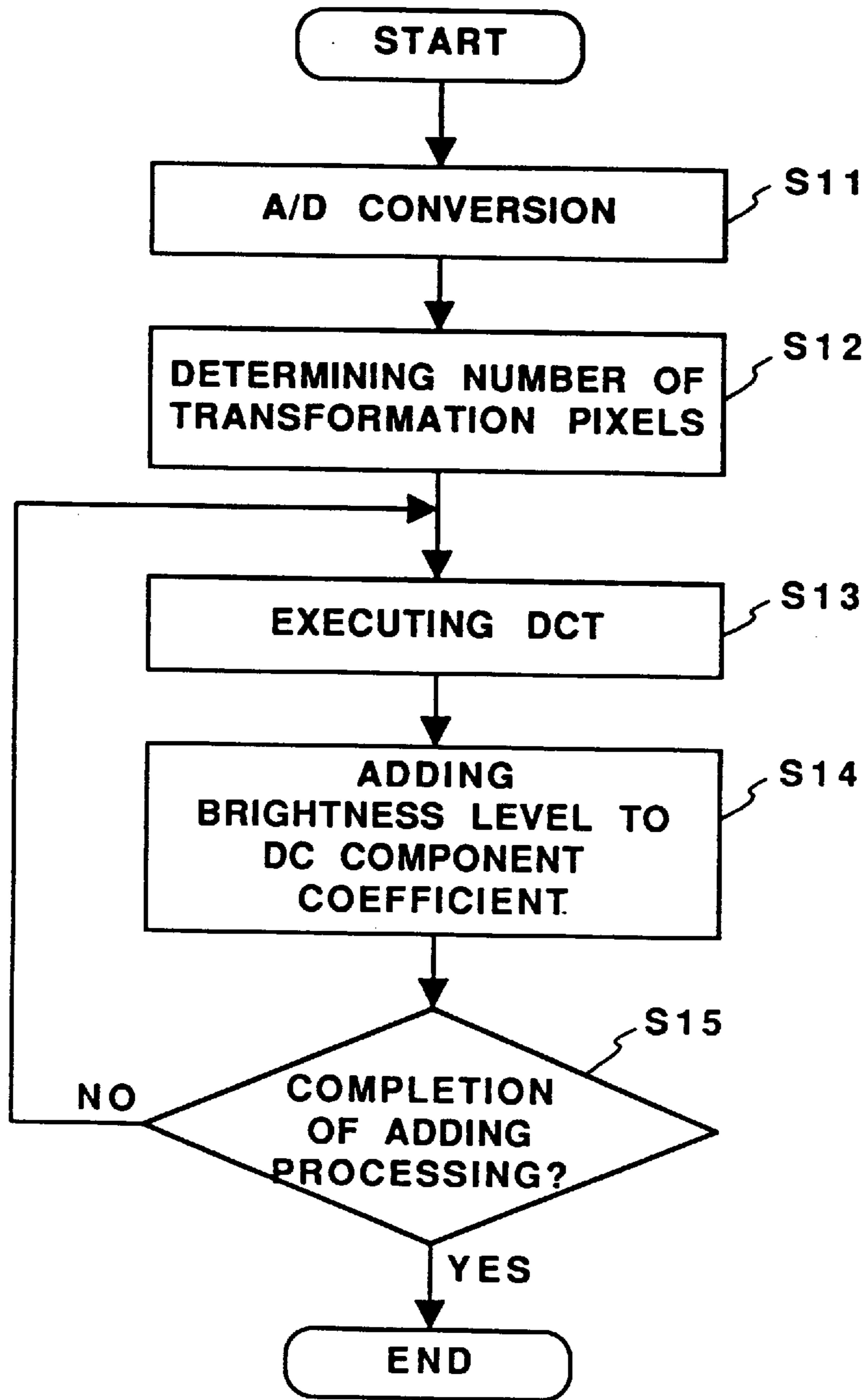

FIG. 3

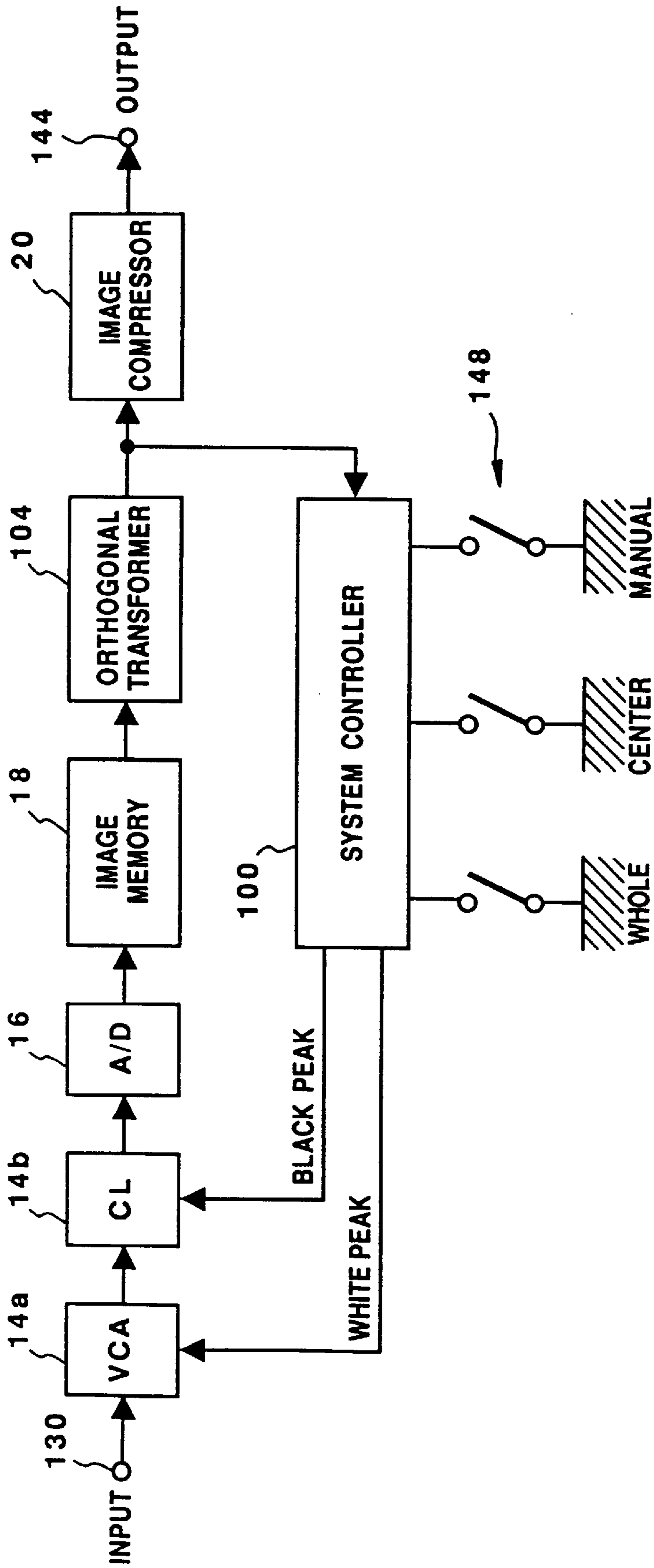

FIG. 4

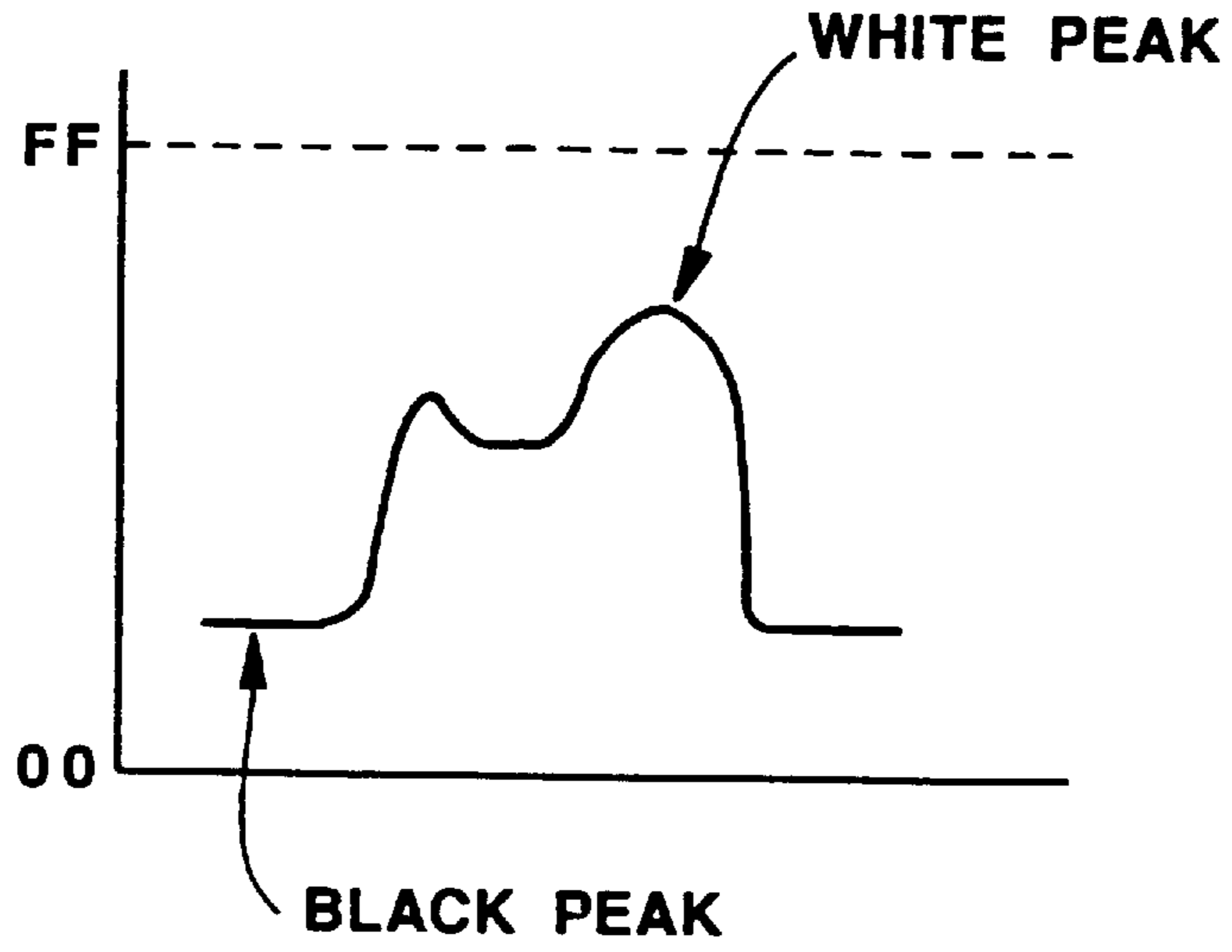

FIG. 5A

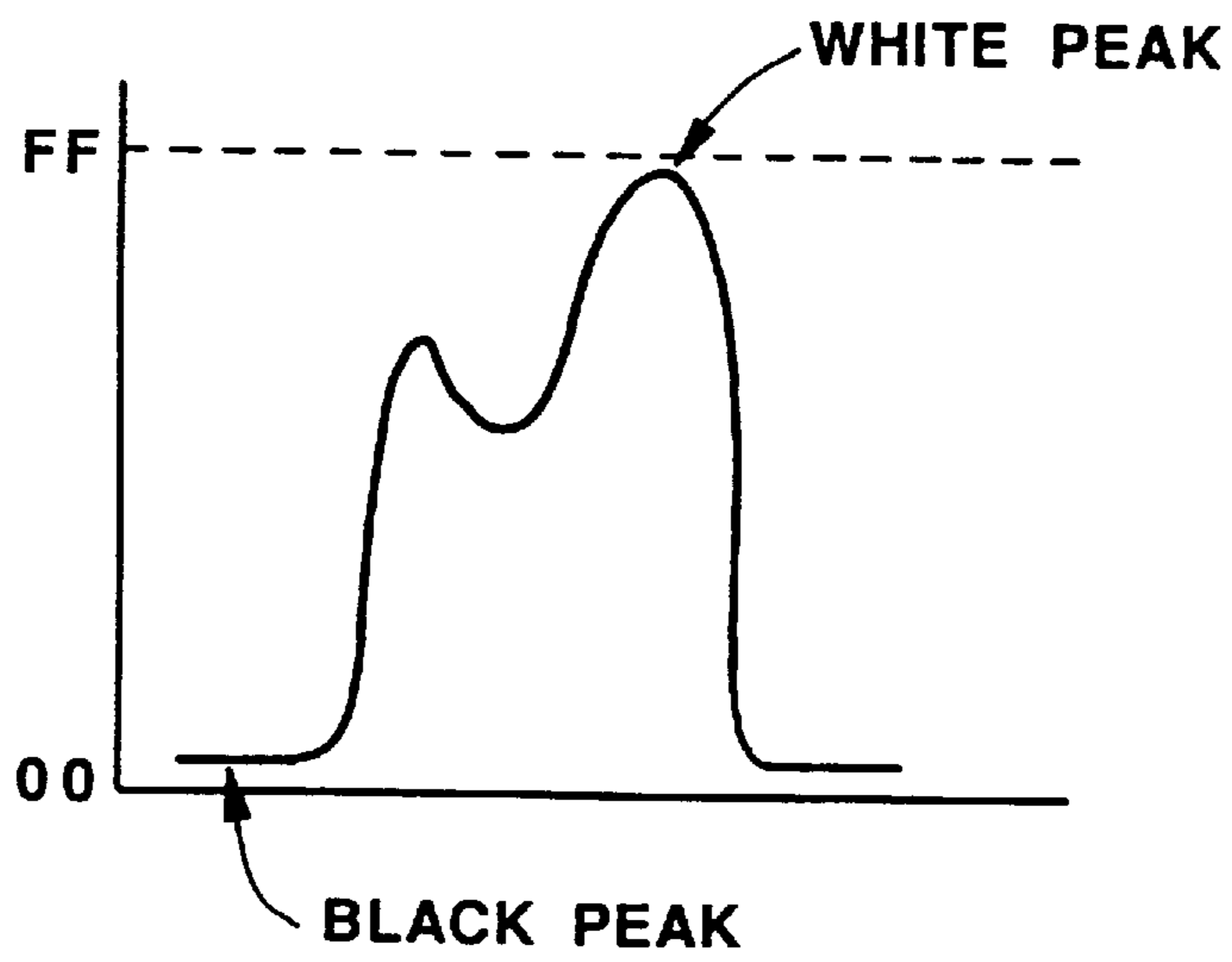

FIG. 5B

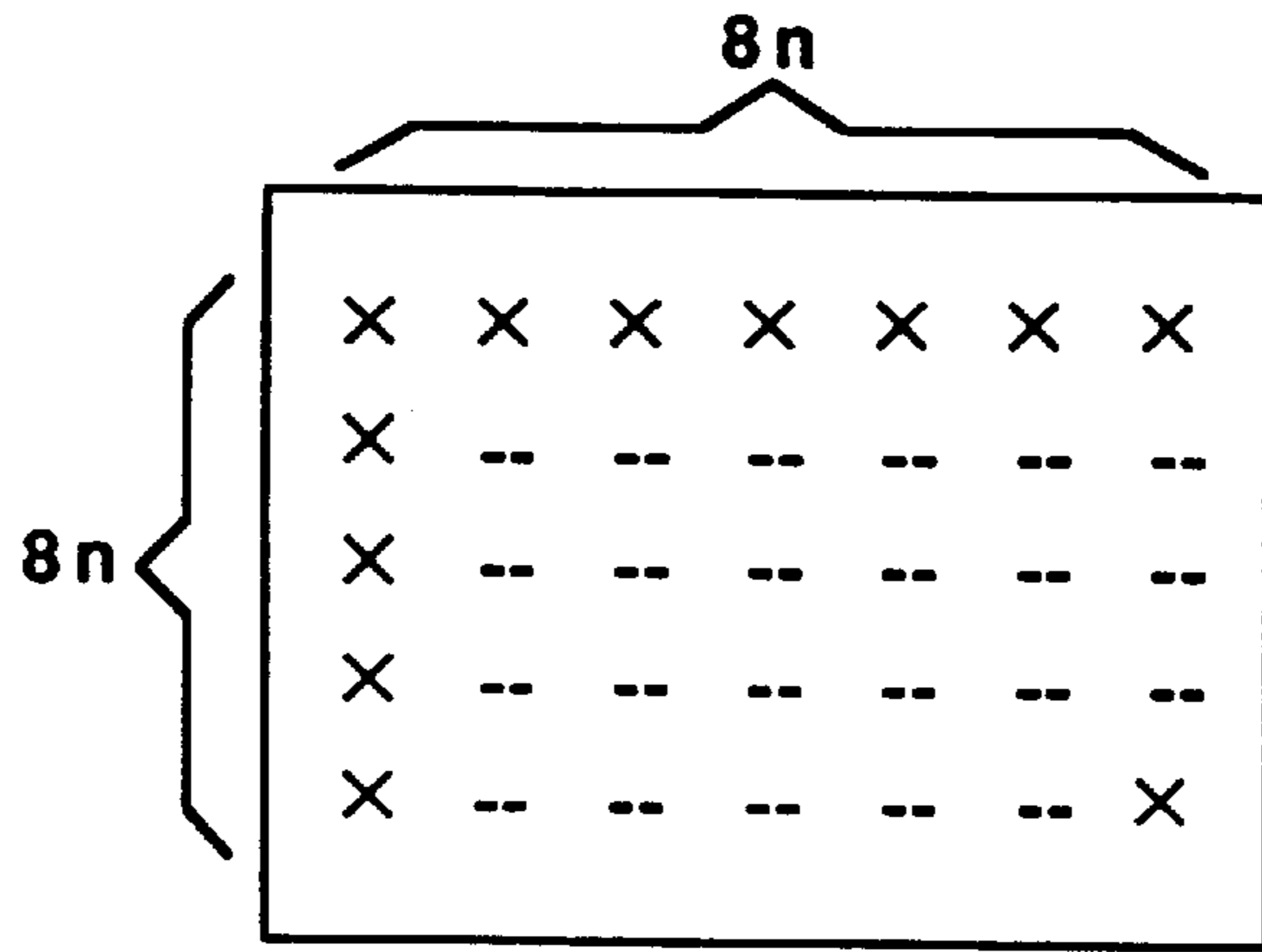

FIG. 6A

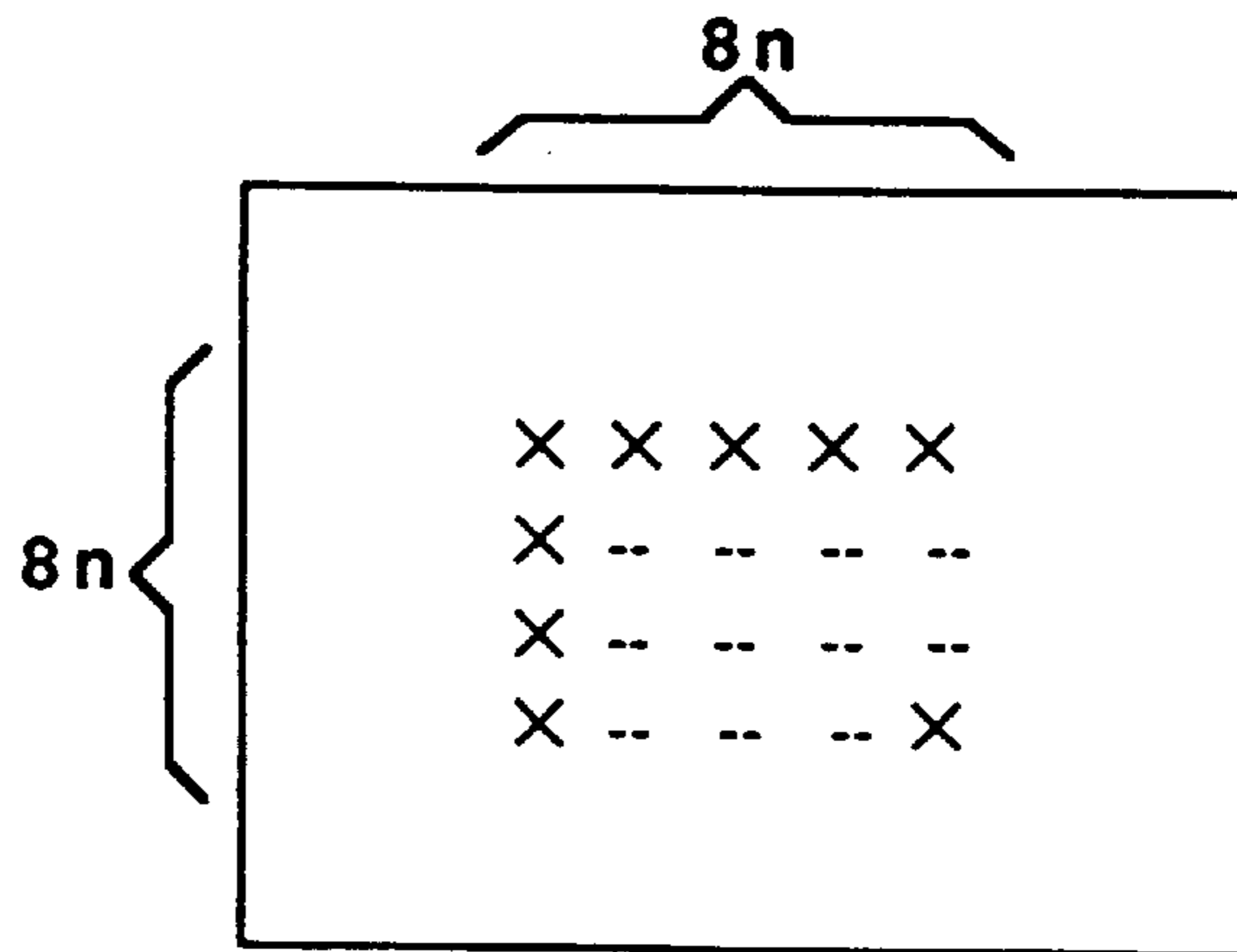

FIG. 6B

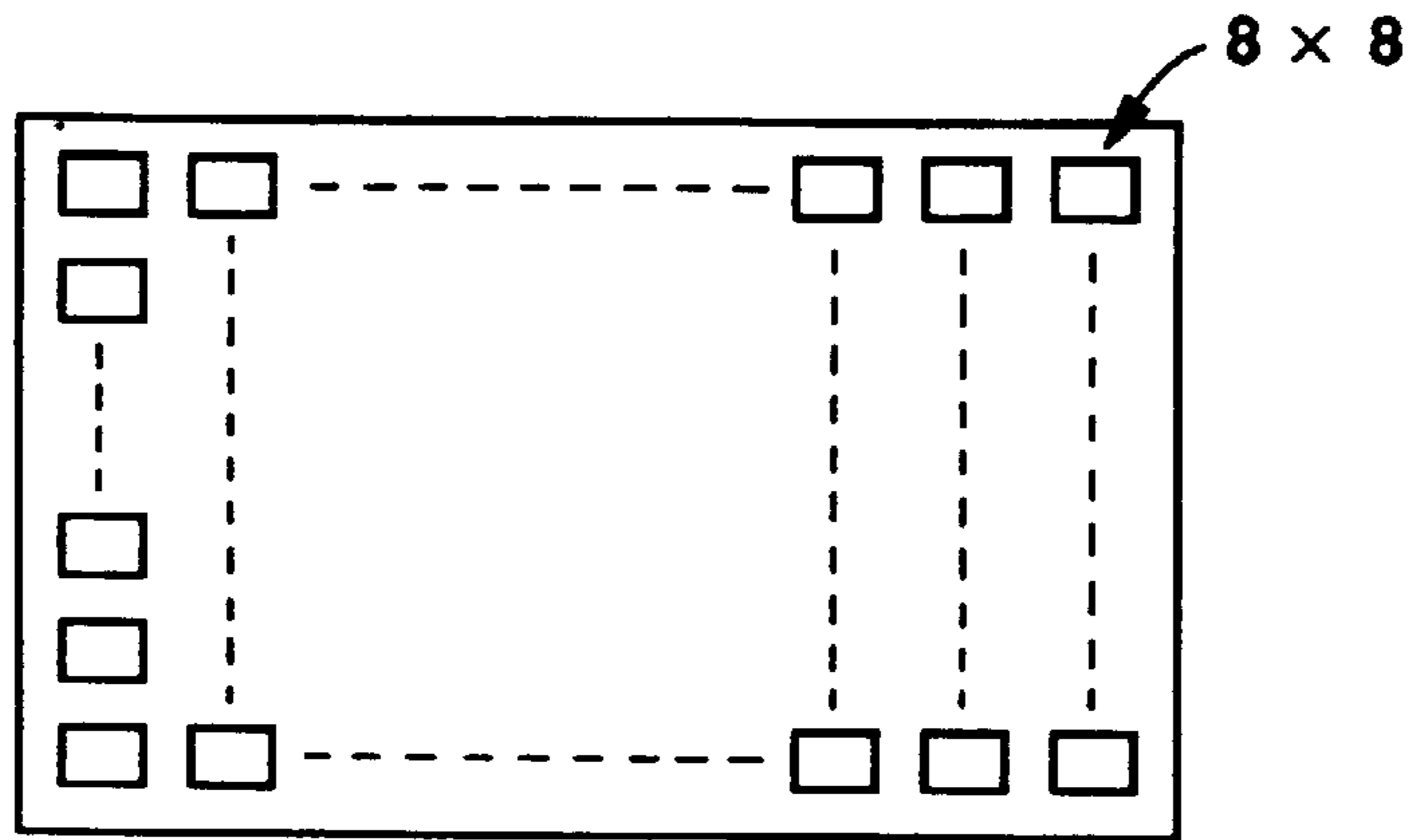

FIG. 6C

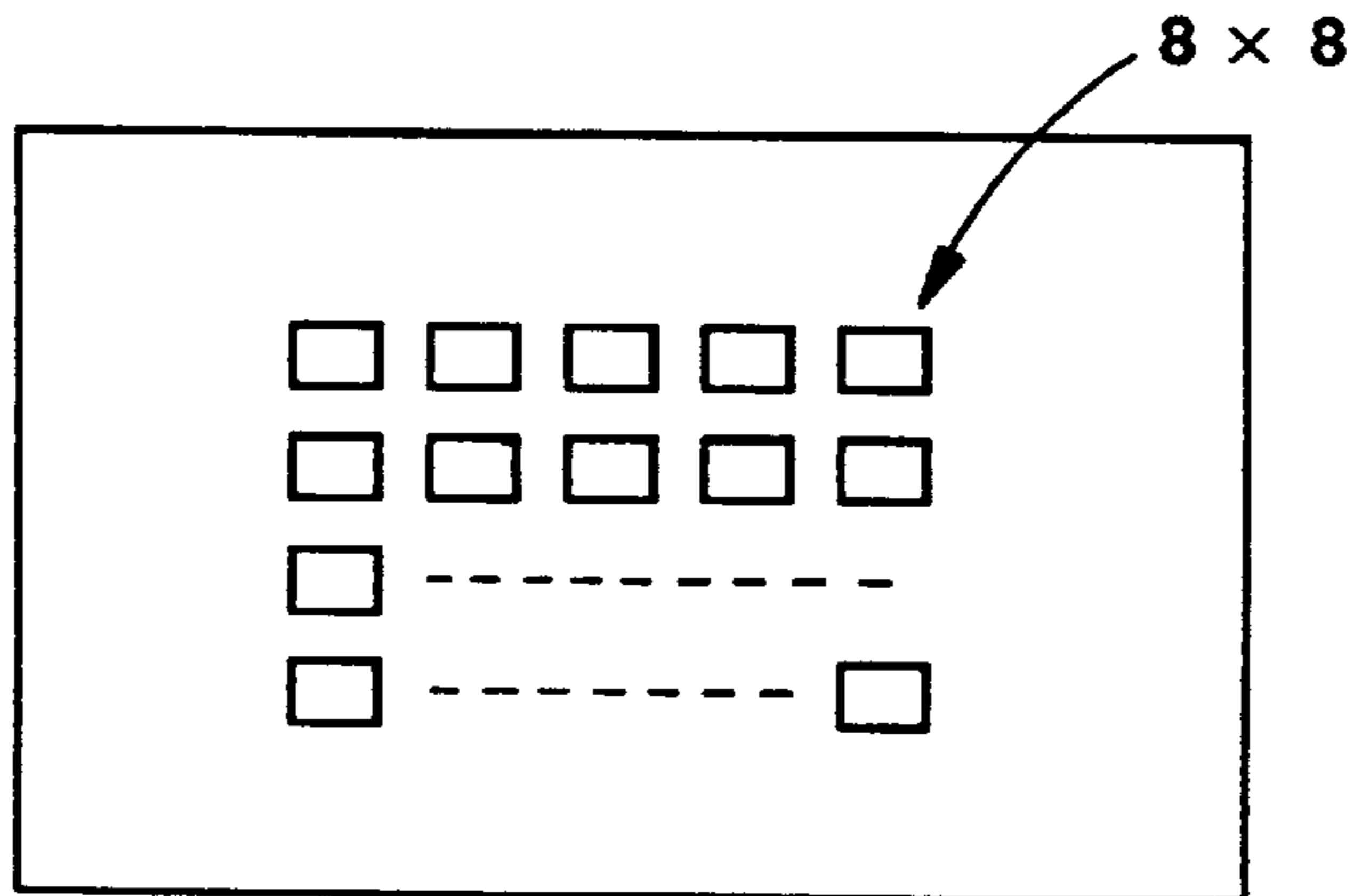

FIG. 6D

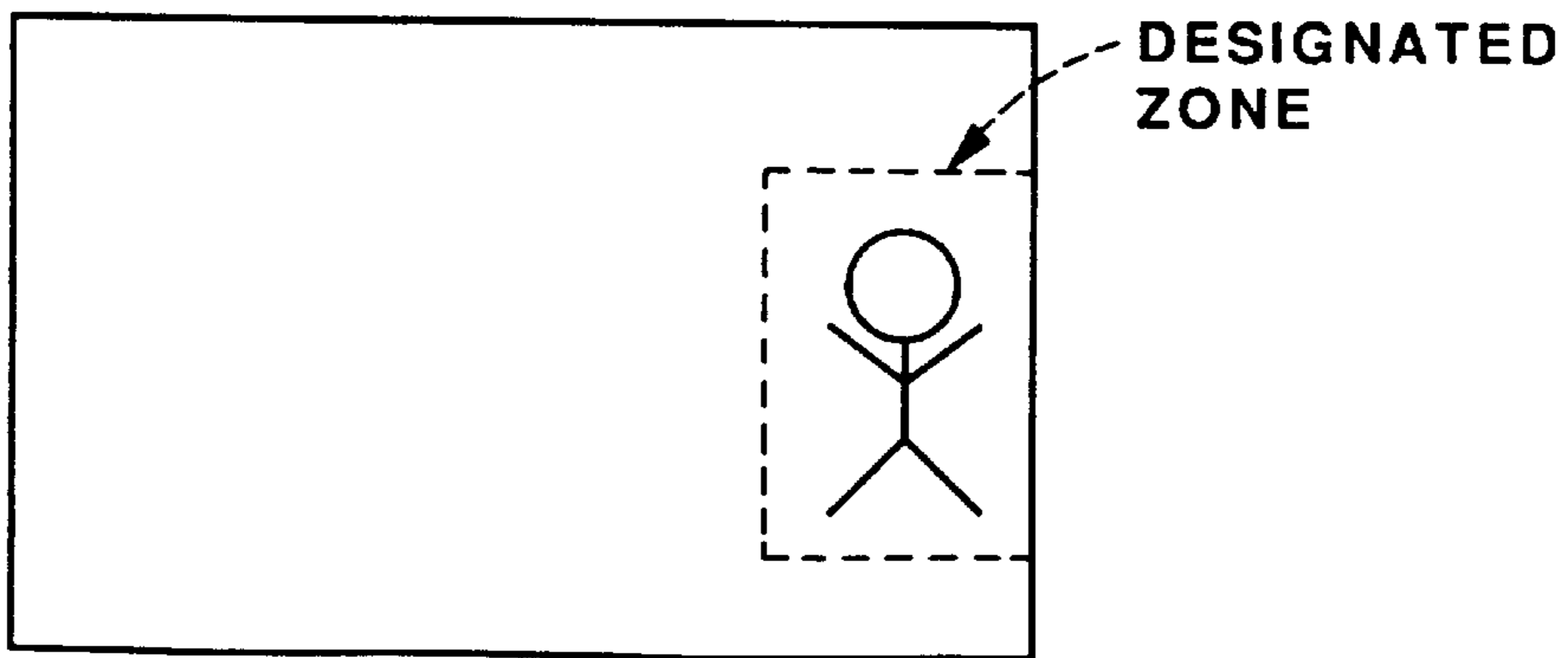

FIG. 6E



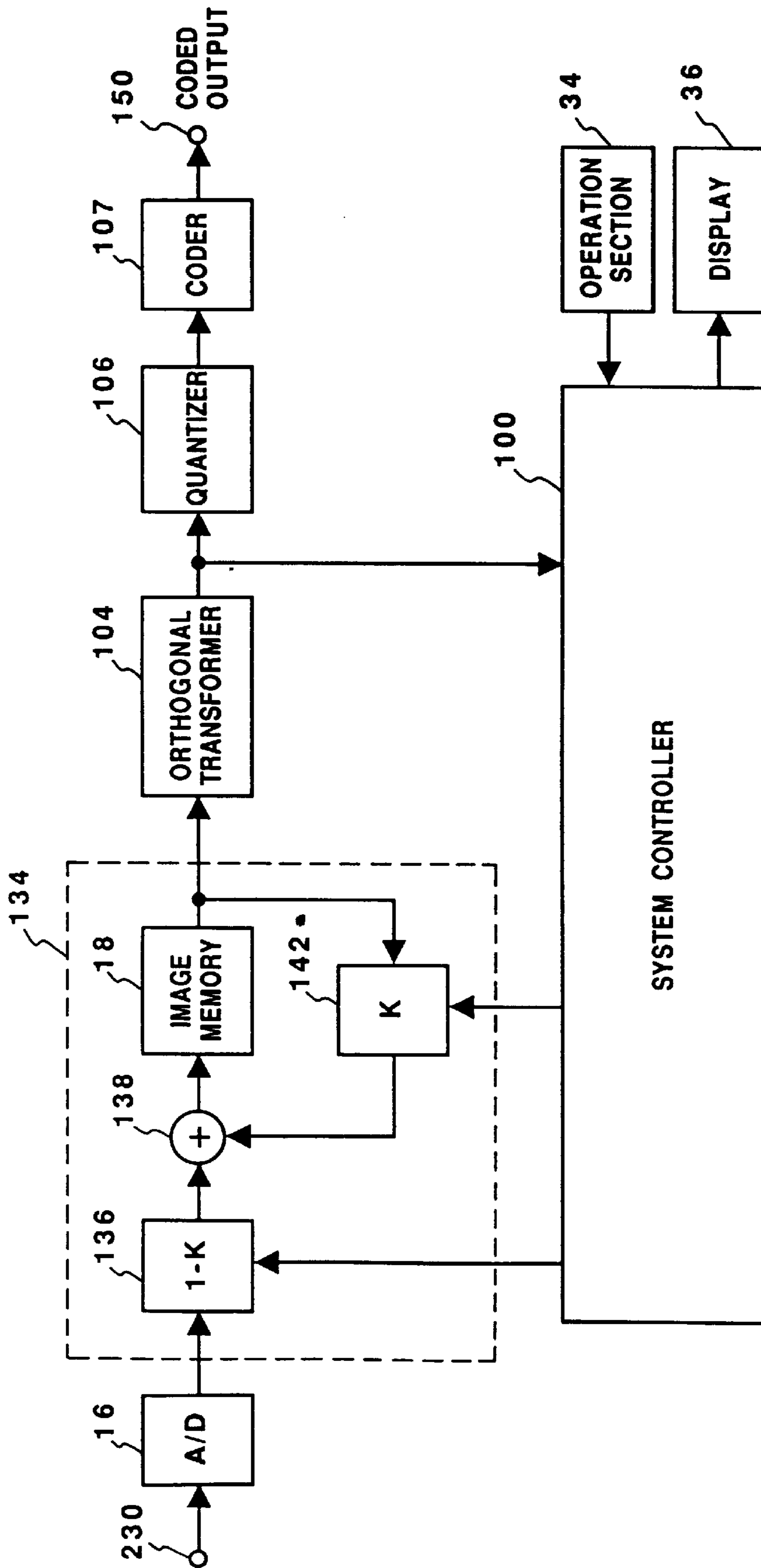

FIG. 7

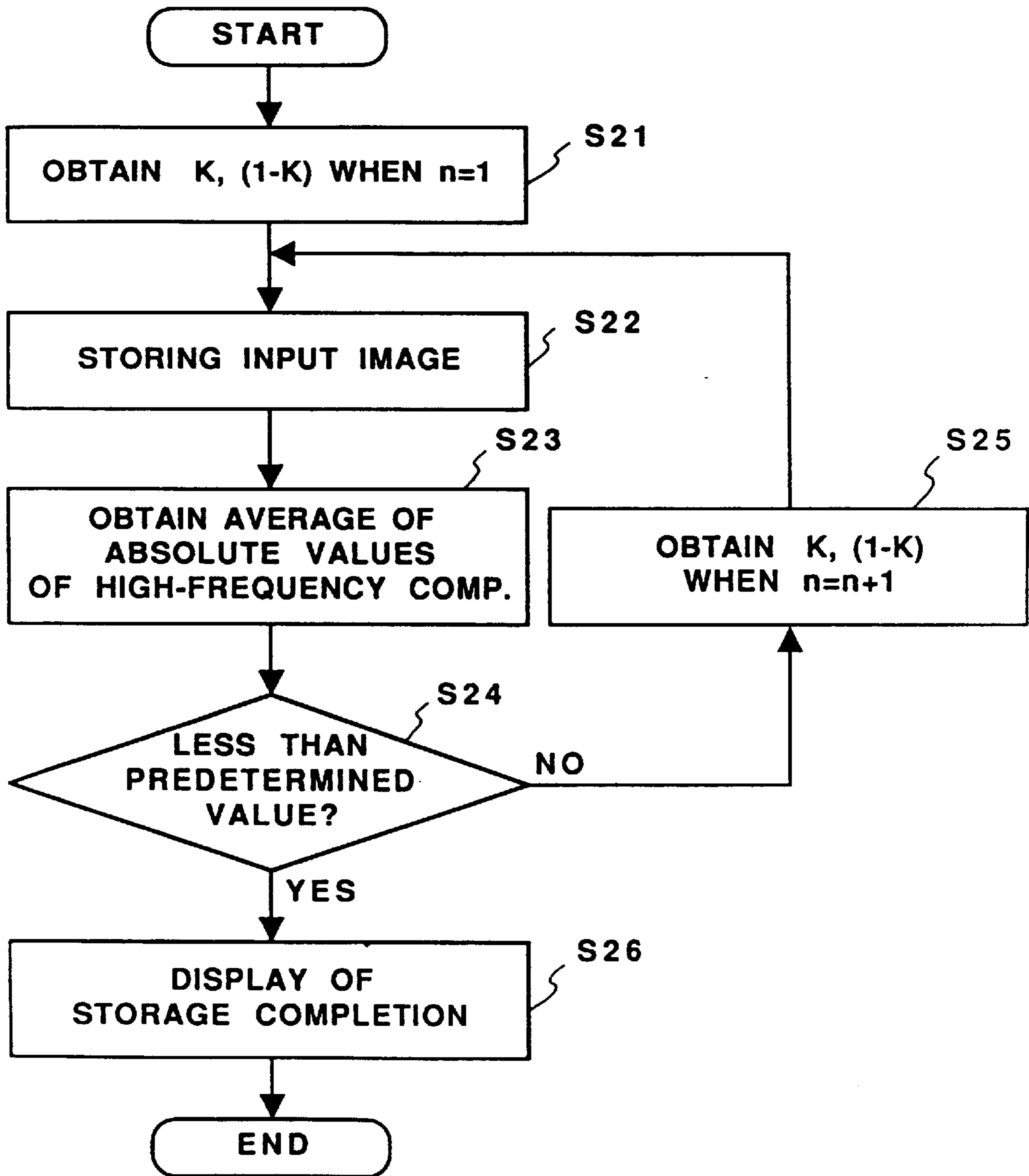

FIG. 8

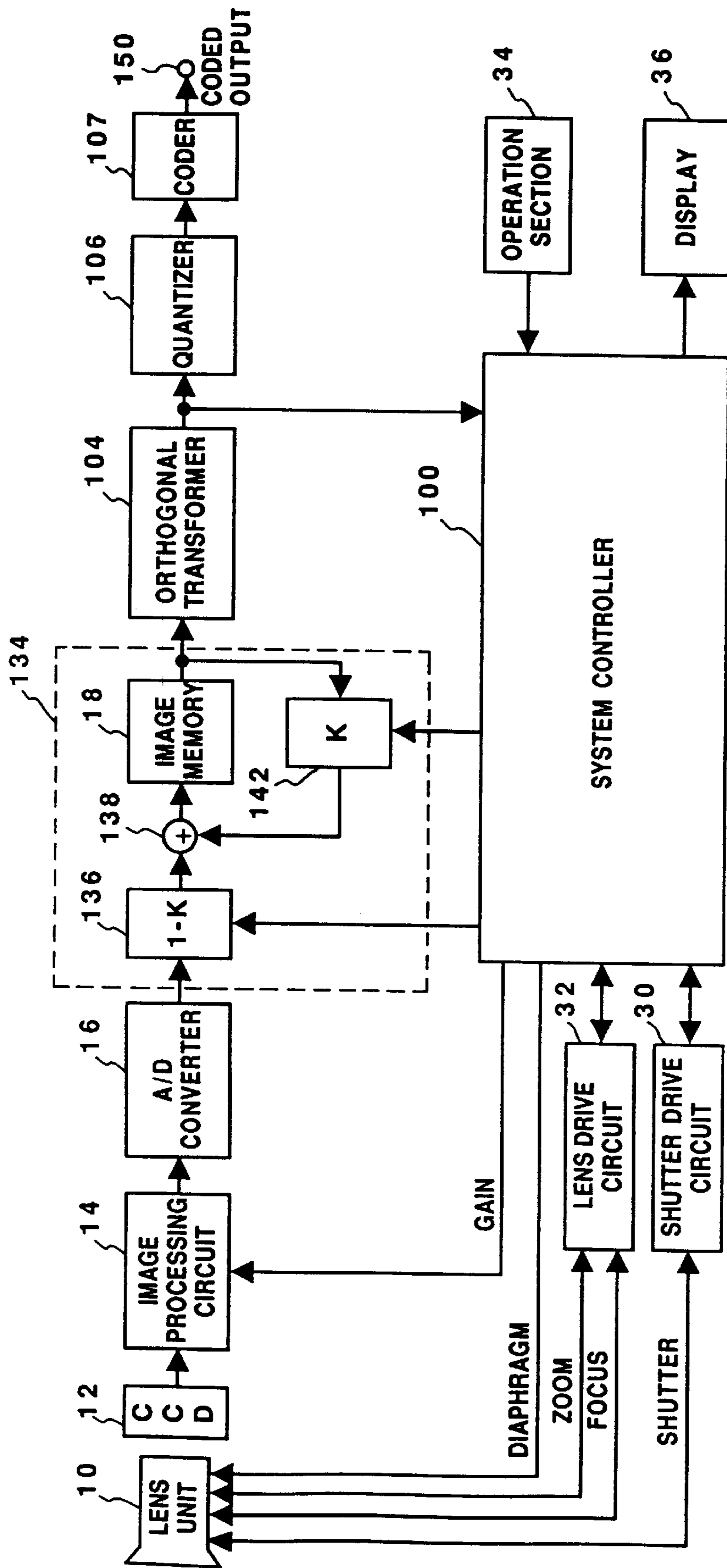

FIG. 9

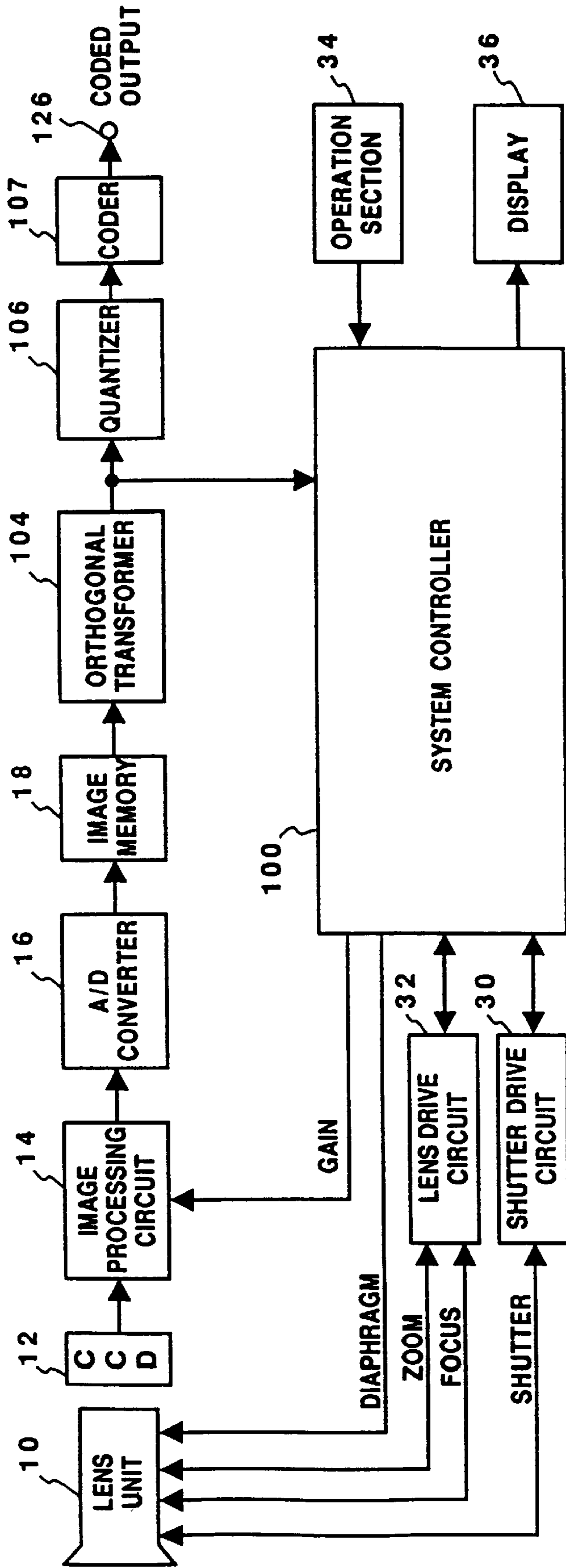

FIG. 10

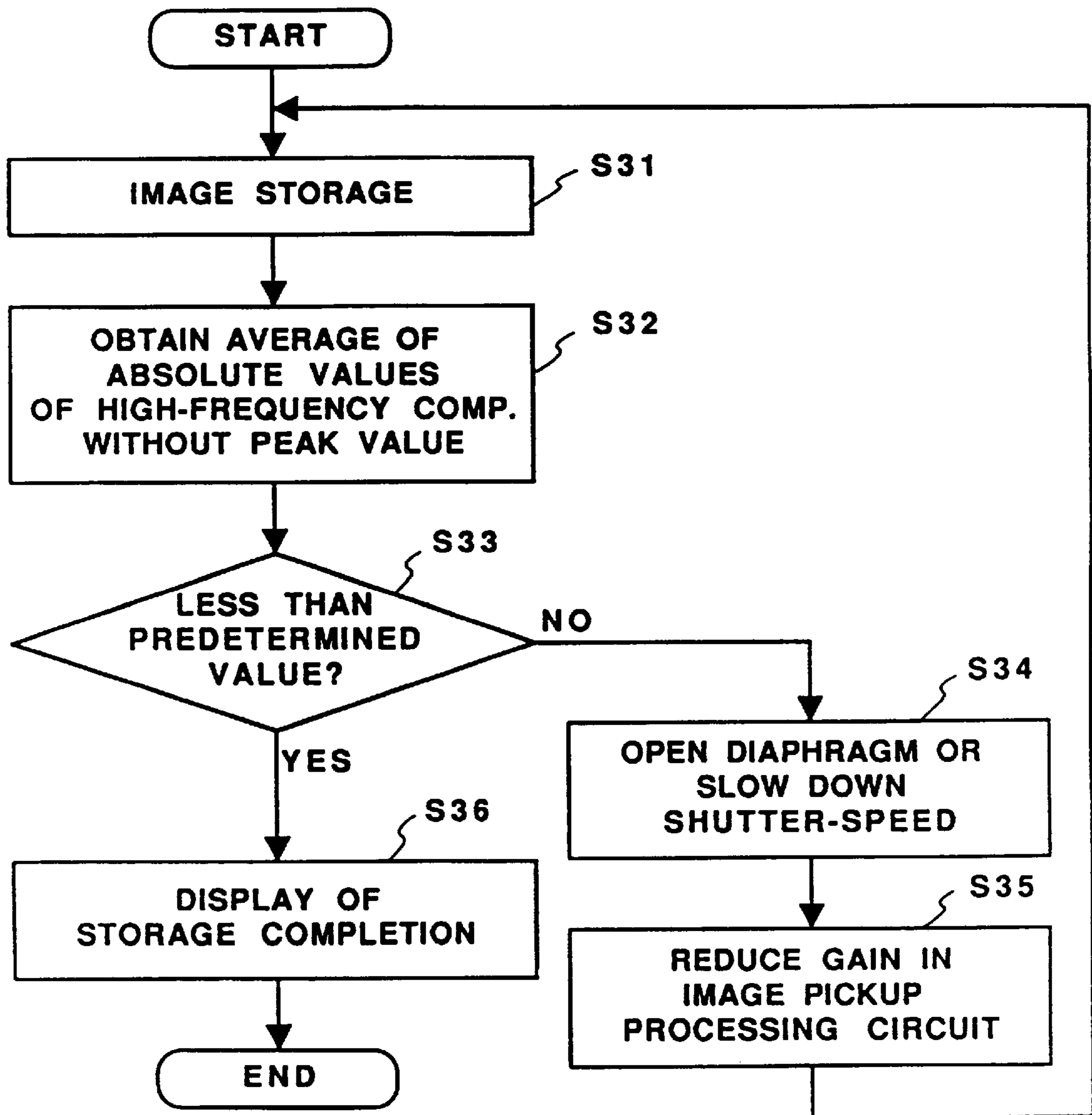

FIG. 11

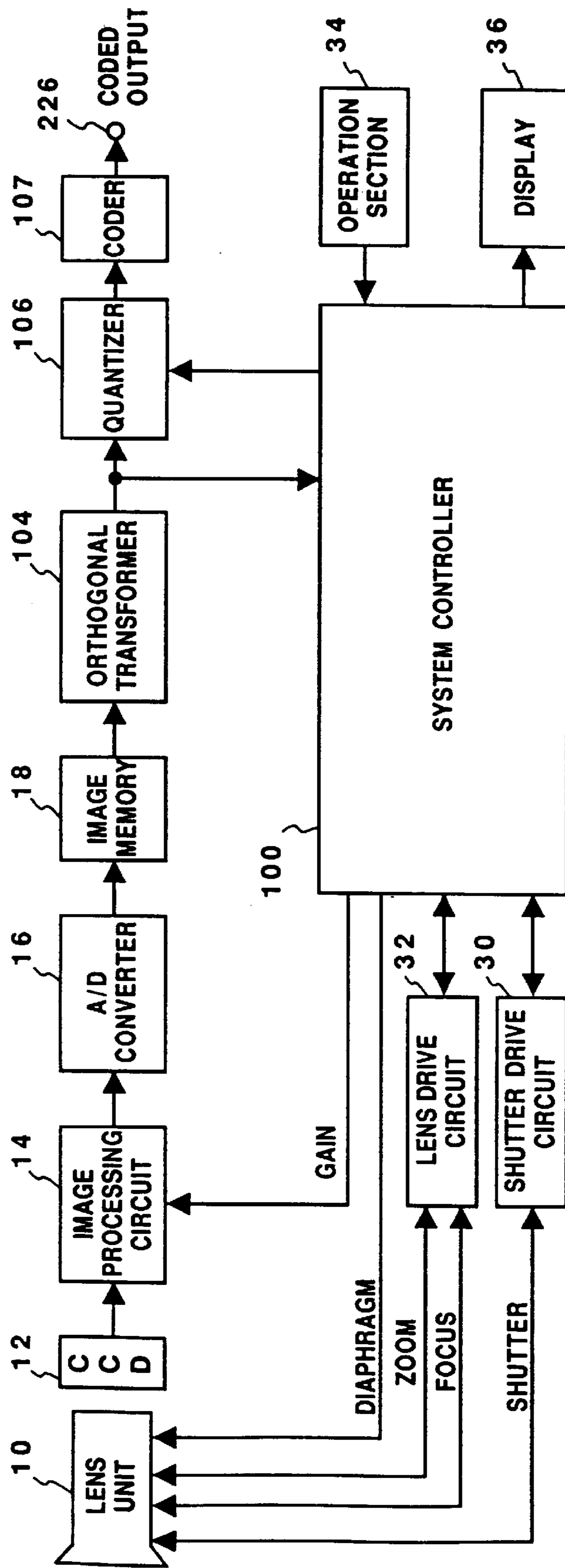

FIG. 12

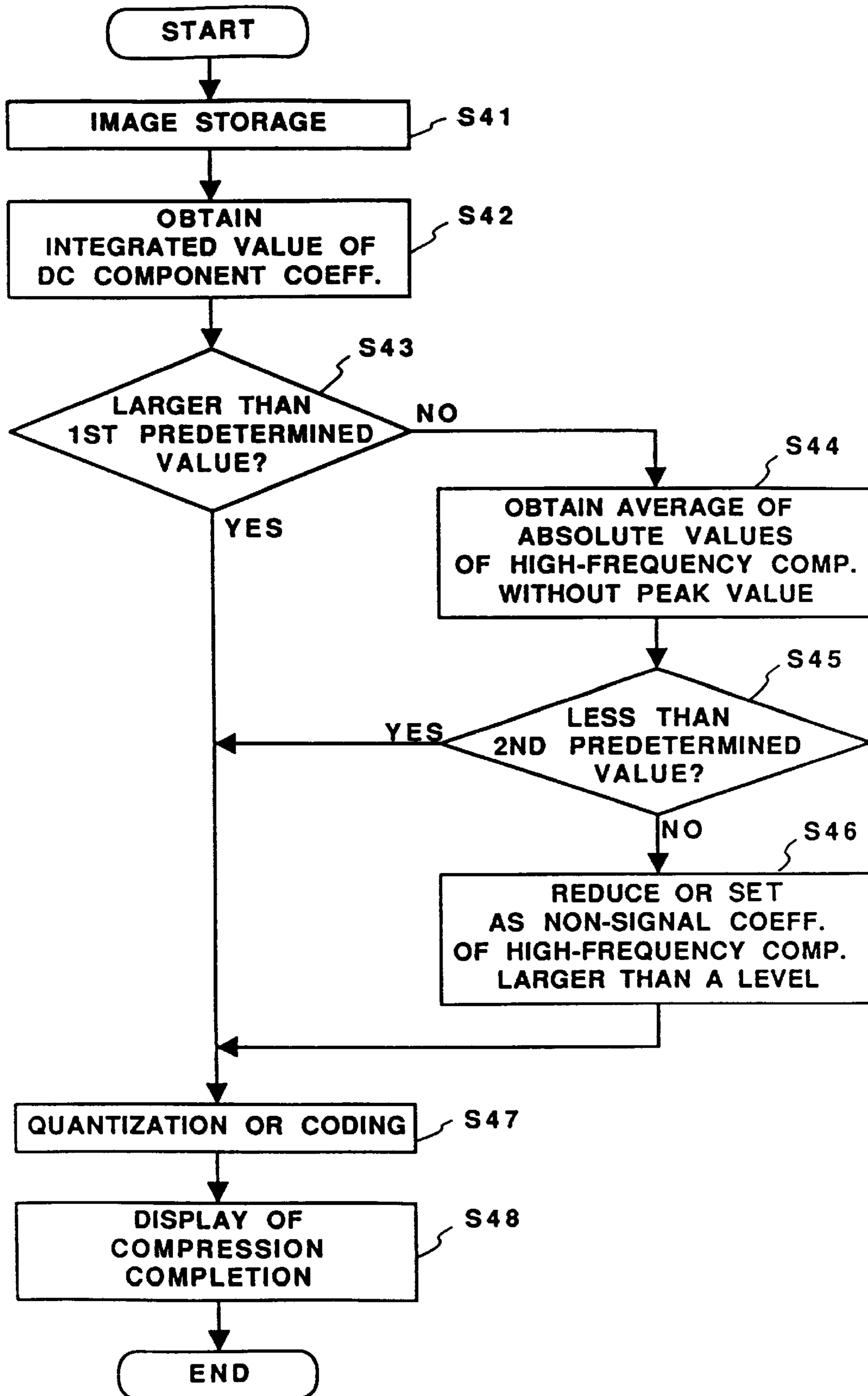

FIG. 13

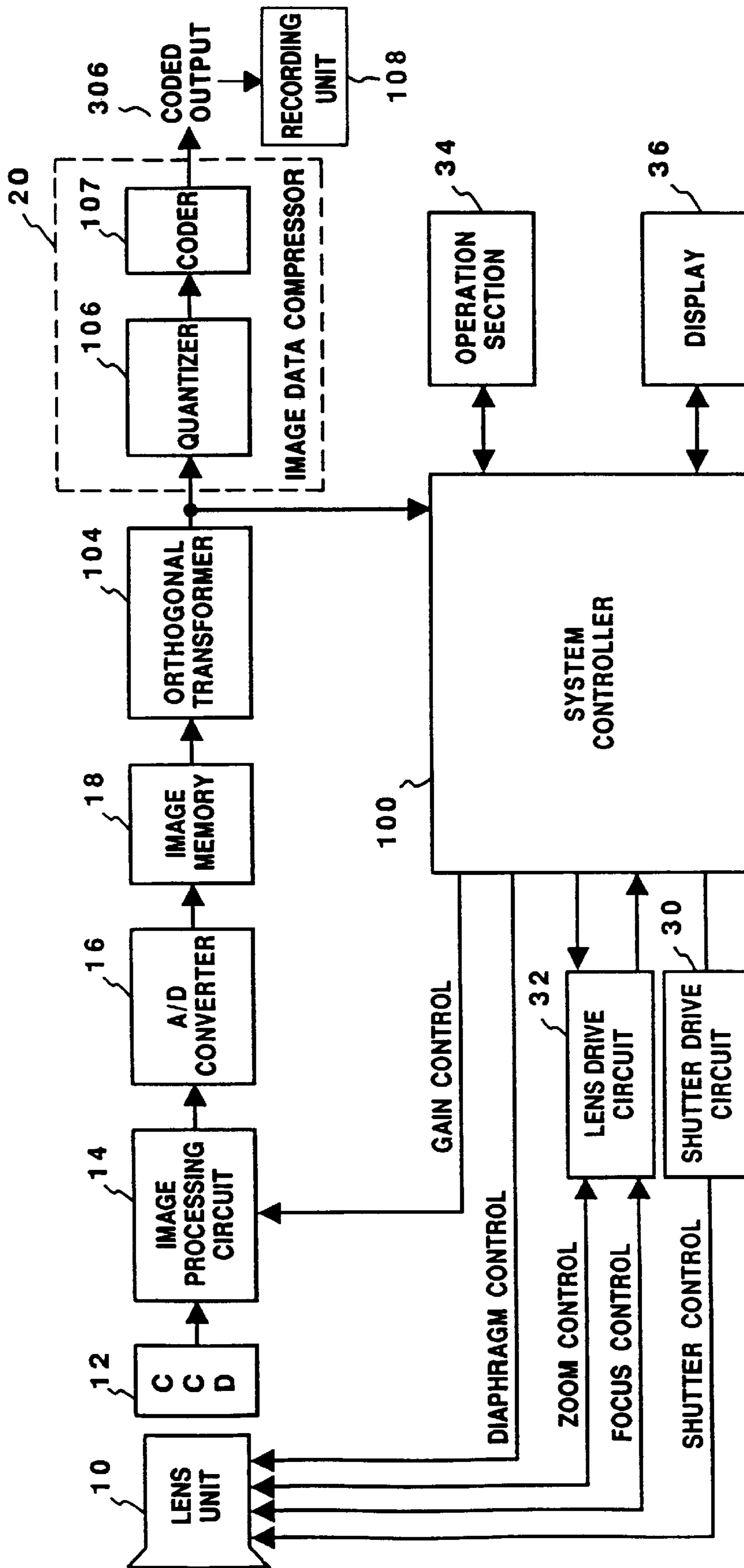

FIG. 14



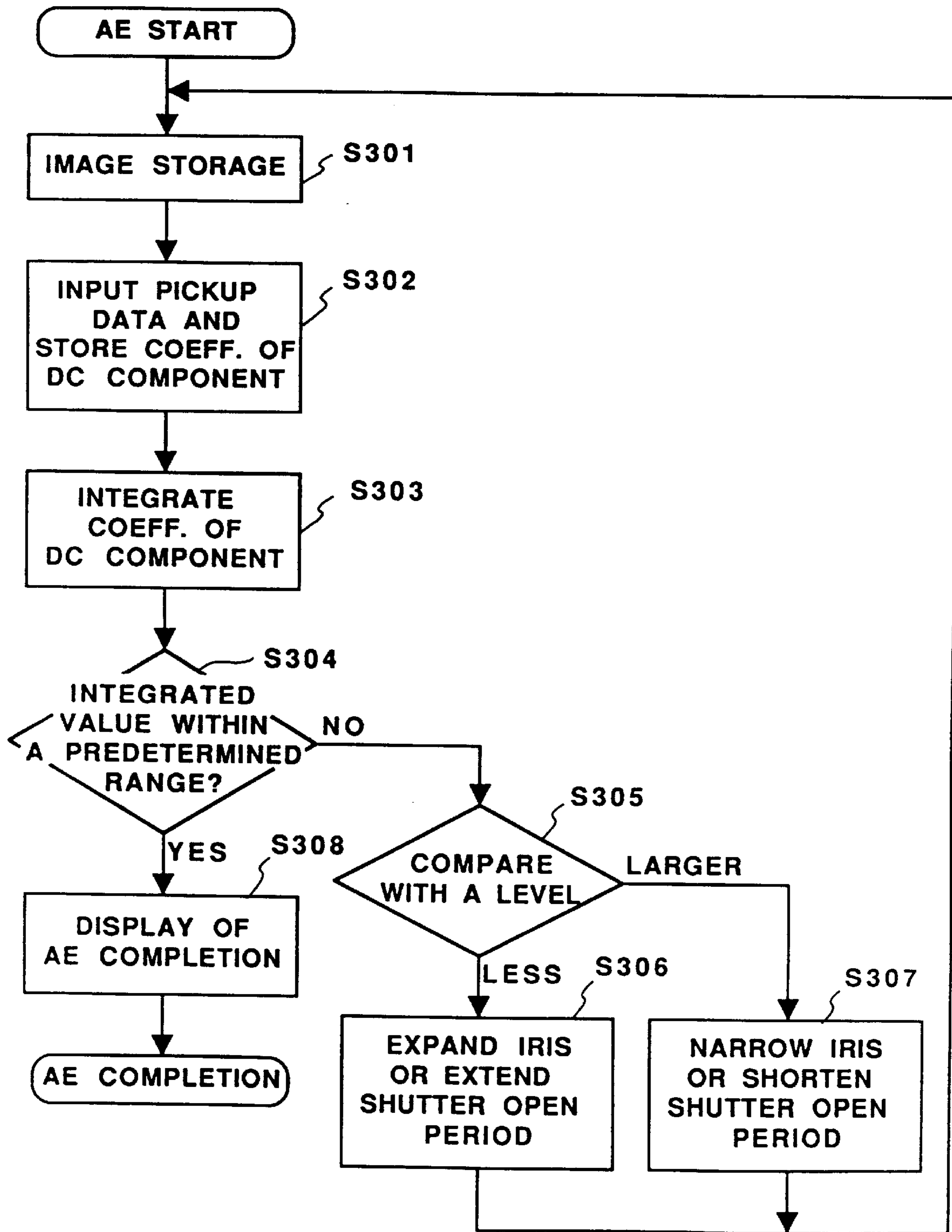

FIG. 15

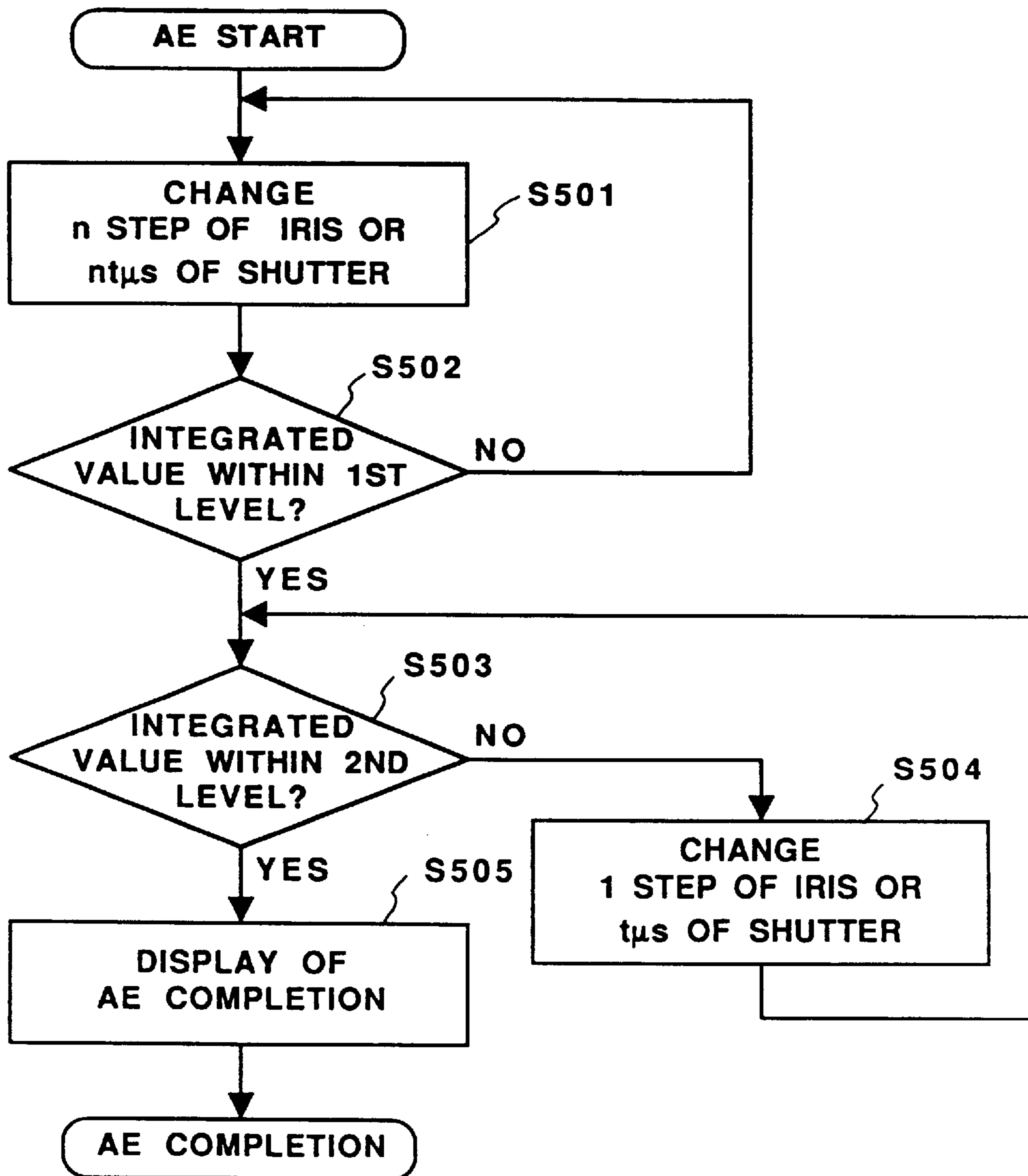

FIG. 16

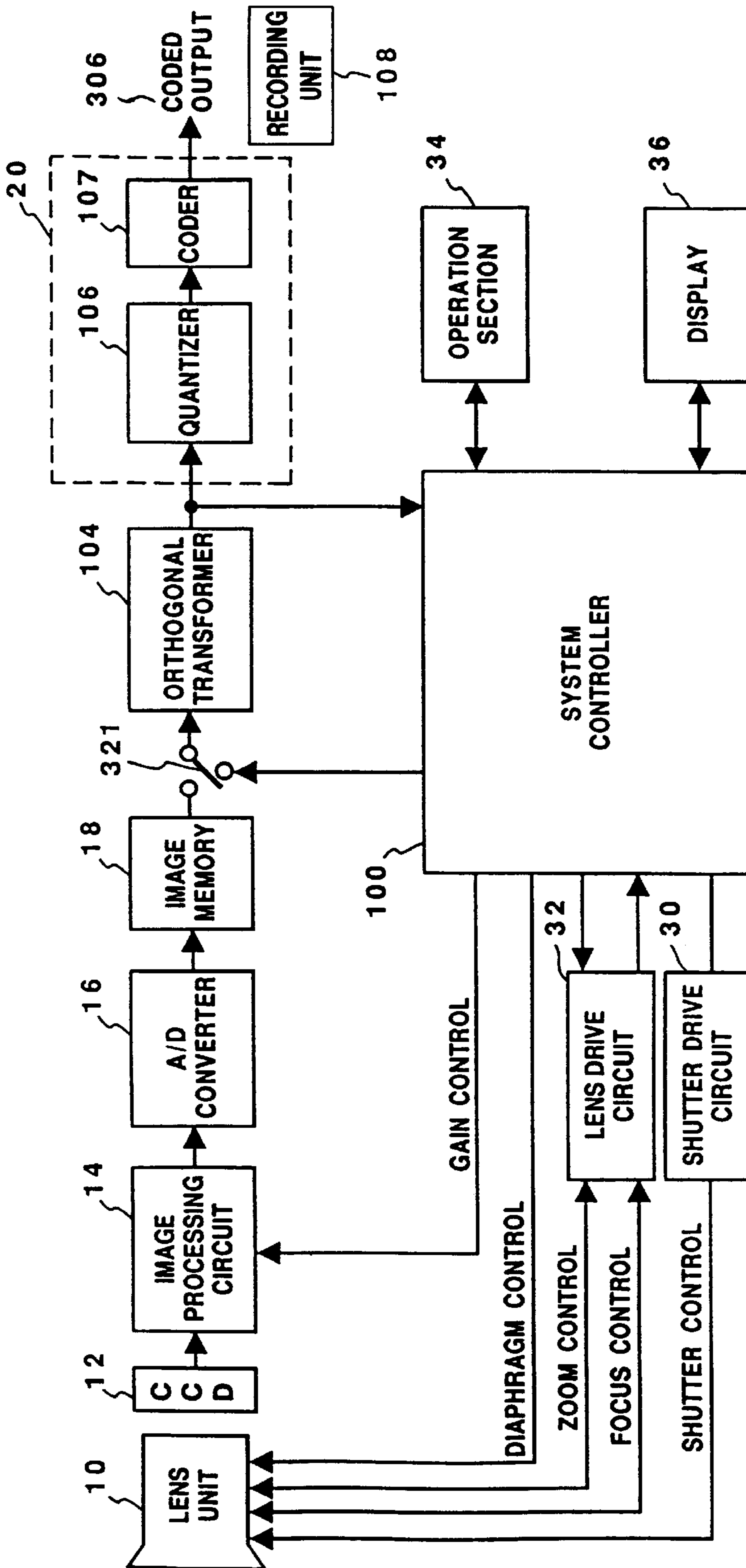

FIG. 17

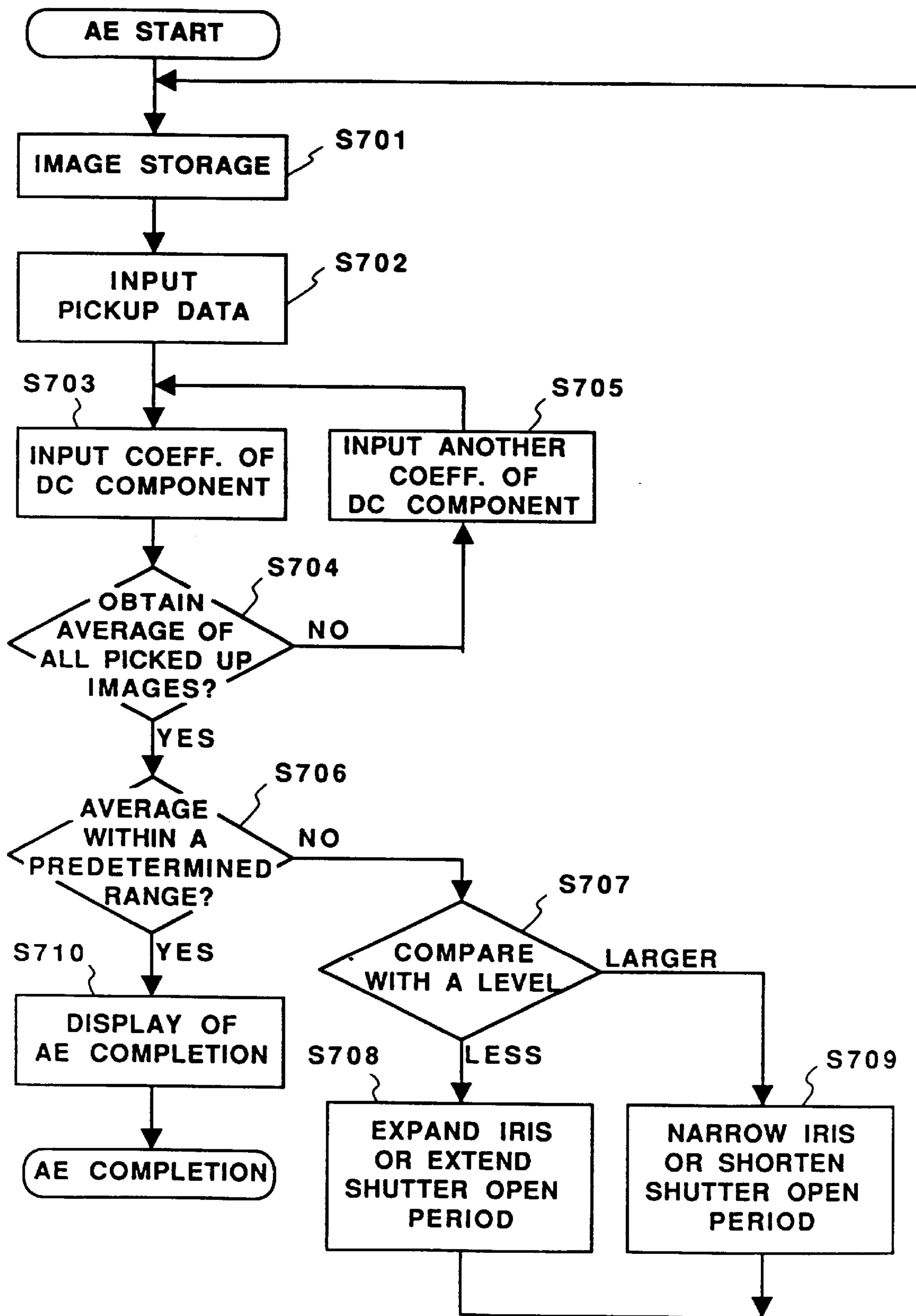

FIG. 18

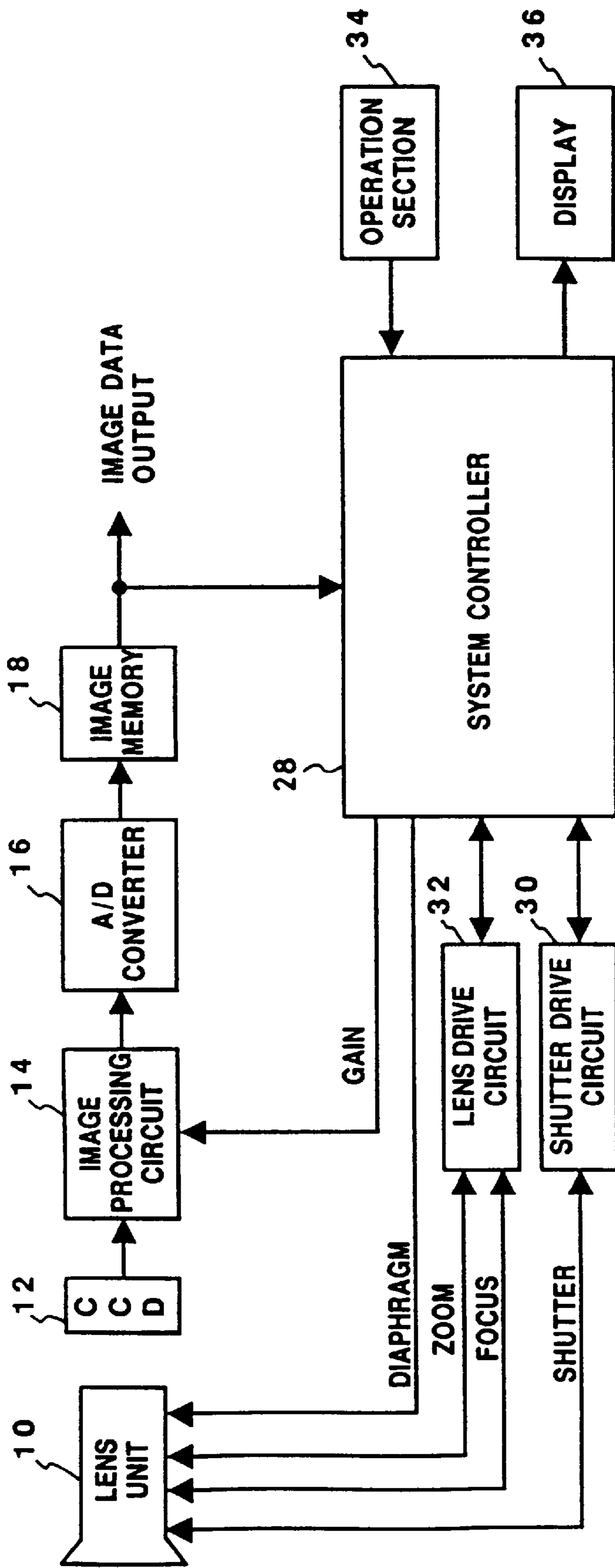
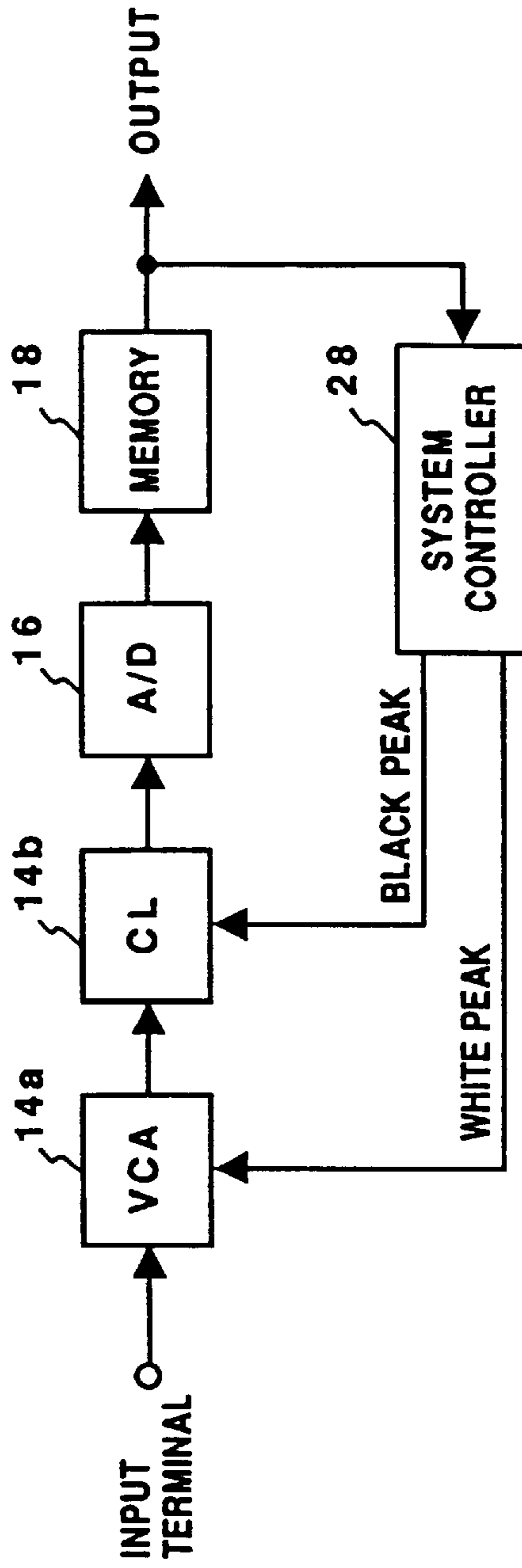

FIG. 19  
PRIOR ART



**FIG. 20**  
PRIOR ART

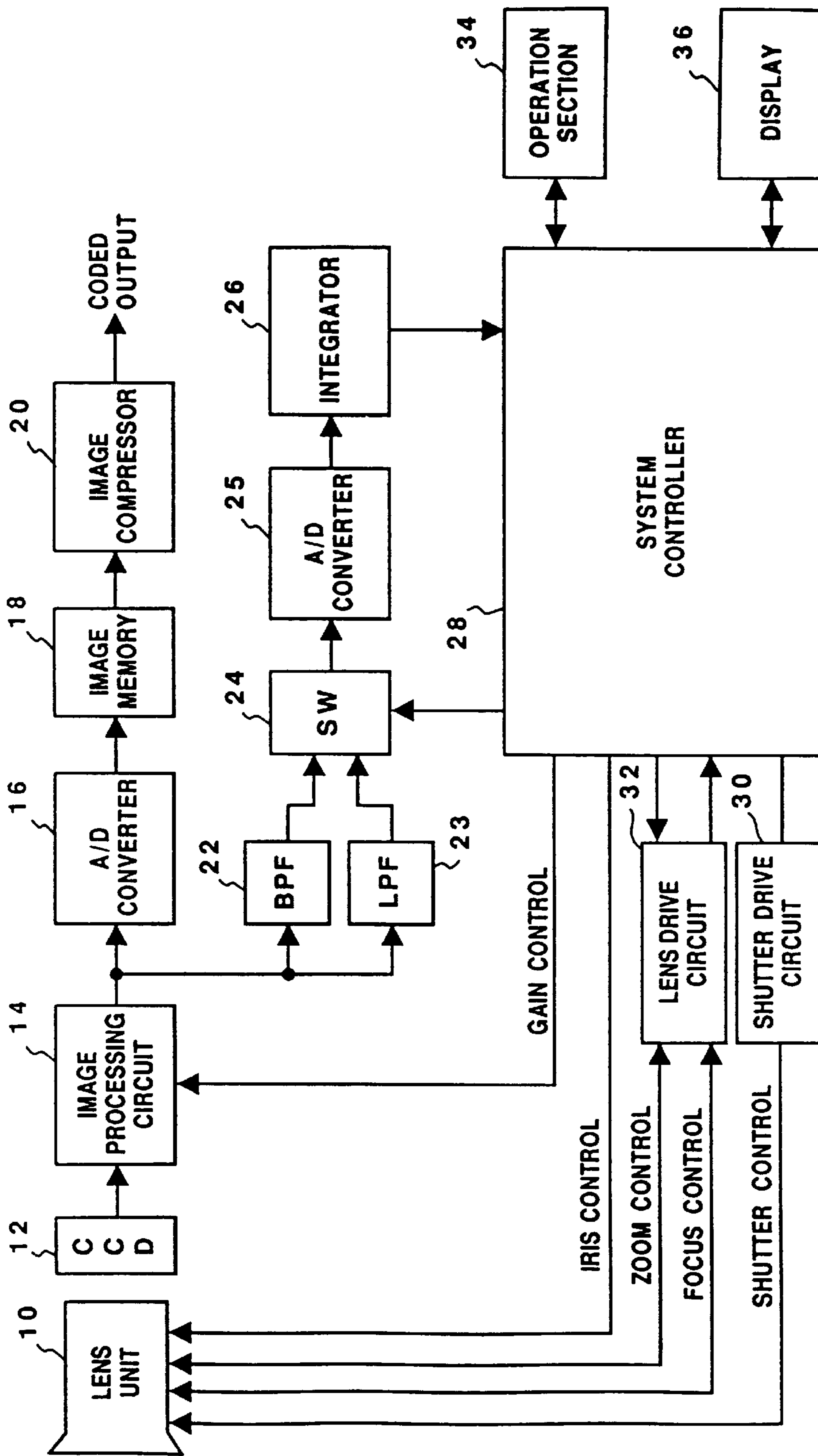

FIG. 21  
PRIOR ART

**IMAGE PROCESSING APPARATUS HAVING  
MEANS FOR CONTROLLING EXPOSURE  
USING AN ORTHOGONAL  
TRANSFORMATION COEFFICIENT**

This application is a division of application Ser. No. 07/881,866 filed May 12, 1992.

**BACKGROUND OF THE INVENTION**

**1. Field of the Invention**

The present invention relates to an image processing apparatus and, more particularly, to an image processing apparatus which encodes and outputs an image signal which was inputted from an image pickup section.

**2. Description of the Related Art**

The typical examples for the above-described image processing apparatus are an electronic camera and a video camera. In an electronic camera, the controls such as the shutter speed, focus, zoom, and diaphragm (lens aperture) controls are performed in the lens unit. A gain control is performed in the image pickup section by processing a signal, which was photoelectrically converted and outputted from a CCD. These controls, i.e., the diaphragm and gain controls, are called the automatic exposure control (which is referred to as AE below). The gain control is performed by a voltage control amplifier (referred to as VCA) and clamping circuit (referred to as CL). A video signal which is outputted from the image pickup section is converted to a digital signal by an A/D converter and stored in memory. Then, the digital signal which was read out from the memory is compressed and encoded respectively by a quantizer and coder, and then outputted as coded output.

However, in conventional image processing, the aforementioned controls and the adjustment for the brightness level are complicated which causes the apparatus to be quite large. In addition, since noise removal is not enough, there is the drawback that an efficiency of coding is decreased. A few other drawbacks in the conventional apparatus are further described below.

In an image processing apparatus, which adjusts a brightness level, the following arrangement is well known. First, a video signal is inputted to the A/D converter and converted to a digital signal. The digital signal is stored in the memory. Then, the brightness level which was inputted through a microprocessor (CPU) is added by an adder to every pixel of the video signal which was being stored in the memory. However, since the brightness level needs to be added to each pixel of image data, there are the drawbacks that the number of adding operation is increased, buffer quantity for data which relates to the addition is increased, and the apparatus becomes both complicated and quite large.

FIG. 19 is a block diagram illustrating the arrangement of a conventional electronic camera. The reference numeral 10 is a lens unit comprising a photograph lens, shutter, and diaphragm. The CCD image pickup device 12 converts a subject image picked-up by the lens unit 10 into an electrical signal. The image pickup processing circuit 14 performs a well-known camera signal processing operation such as a gamma correction on the output of the image pickup device 12 and outputs a standard type video signal. The image pickup processing circuit 14 adjusts the gain so that white and black peak levels will be within a predetermined range. The A/D converter 16 digitizes the output of the image pickup processing circuit 14 and the output is temporarily stored in the memory 18. The image data which was read from the memory 18 is either modulated or coded if necessary, and recorded on a recording medium.

The system controller 28 drives a shutter of the lens unit 10 by the shutter drive circuit 30 and also drives a focusing lens and zooming lens by the lens drive circuit 32. Furthermore, the system controller 28 directly controls a diaphragm. Instructions for photographing and the like are inputted to the system controller 28 in a manner such that a user operates the operation section 34. The display section 36 displays the state of operation.

The system controller 28 calculates the white and black peak levels in a screen (or a predetermined area) from the output of the A/D converter 16 (or the memory 18) and controls the gain of the image pickup processing circuit 14 so that the levels will be at a predetermined level.

On the other hand, in an electronic camera which electromagnetically records a still image and a moving image, e.g. an electronic still camera and video camera, the method such that an image is compressed and stored using a recording medium in digital recording has recently been of interest. In this method, because of the digital recording, image deterioration by duplication is decreased and many images can be recorded in a small recording capacity because of compression recording.

However, in the above-described electronic camera in the case of photographing at a low light intensity or at a high shutter-speed, the S/N ratio of the output signal of the image pickup device 12 deteriorates, and if the image is compressed as it is, the quality of the image decreases. Furthermore, there is another drawback such that the compressing efficiency is decreased, since a high-frequency component of an image having a deteriorated S/N ratio is large.

Furthermore, in the case where an image source to be compressed is a reproduction image of a video tape recorder or an output of a TV tuner, the image does not have a sufficient S/N ratio. If such an image is compressed as is, not only is the quality of the image decreased, but also the efficiency of compression is decreased.

As an example, a block diagram of the gain adjustment arrangement in the conventional image processing apparatus is shown in FIG. 20. An analog video signal is inputted to an input terminal and the voltage control amplifier (VCA) 14a amplifies the analog video signal to reach a predetermined white peak level and the clamping circuit 14b clamps a DC level so that the analog video signal reaches a predetermined black peak level.

The output of the clamping circuit 14b is converted to a digital signal by the A/D converter 16 and stored in the memory 18.

The system controller 28 comprising a microcomputer seeks white and black peak levels from the output of the memory 18 and controls the gain of the VCA 14a and the clamping level of the clamping circuit 14b so that the dynamic range of the A/D converter 16 is fully utilized. For example, if the range of the A/D converter 16 is set from "0" to "FF" (hexadecimal notation), the video signal of white and black peaks shown in FIG. 5A is expanded to the video signal shown in FIG. 5B.

However, in the conventional apparatus, since the white and black peaks are detected from the signal after the A/D conversion, there is a drawback such that the processing of the gain adjustment is susceptible to noise, impulse noise in particular. That is, there is a drawback such that false peak levels are detected and the dynamic range of the A/D converter 16 cannot be efficiently utilized.

This drawback has also arisen when the image data stored in the memory is compressed.



The apparatus which performs AE control is shown in FIG. 21. As shown in the diagram, the image is converted to an electrical signal in the lens unit 10 and the solid state pickup device 12 (which is referred to as CCD below), and then converted to a video signal in the image processing circuit 14. It is further converted to a digital signal in the A/D converter 16 and stored in memory 18. It is then compressed by the image data compressor 20 and the coded output is outputted.

Finally, the AE operation is described. The video signal which was obtained in the CCD 12 and the image processing circuit 14 is converted to a digital signal by the A/D converter 25 through the LPF (low-pass filter) 23 and the SW (switch) 24. Then, the digital signal is integrated by the integrator 26 and inputted into the system controller 28. While the output of the integrator 26 is supervised optimize the inputted light quantity of the CCD 12, the system controller 28 controls an amplifier gain of the iris, or diaphragm, control and image processing circuit 14 and performs automatic exposing.

However, in this conventional apparatus, since the LPF 23, SW 24, A/D converter 25, and integrator 26 are necessary for AE, there are drawbacks that the arrangement of the apparatus becomes complicated resulting in a increased cost.

### SUMMARY OF THE INVENTION

Accordingly, it is an object of the present invention to provide an image processing apparatus which improves the quality of an inputted image, a pickup image in particular, by a simple arrangement, and also improves the compressing efficiency in a case of compression.

It is another object of the present invention to provide an image processing apparatus capable of high speed adjustment of a brightness level by a simple arrangement.

It is another object of the present invention to provide an image processing apparatus which can be insusceptible to impulse noise of an input signal.

It is another object of the present invention to provide an image processing apparatus which can be insusceptible to a quality deterioration of the input signal.

It is another object of the present invention to provide an image processing apparatus which avoids the deterioration of the S/N ratio and improves the efficiency of compression by a simple construction.

It is another object of the present invention to provide an image processing apparatus which performs the most suitable automatic exposure control by a simple arrangement.

According to the present invention, the foregoing object is attained by providing an image processing apparatus which comprises an orthogonal transformation means, controls an image pickup signal on the basis of various components (e.g. DC component and high-frequency component) outputted from the orthogonal transformation means, and improves a quality of the image by this simple arrangement.

Other features and advantages of the present invention will be apparent from the following description taken in conjunction with the accompanying drawings, in which like reference characters designate the same or similar parts throughout the figures thereof.

### BRIEF DESCRIPTION OF THE DRAWINGS

FIG. 1 is a block diagram which illustrates the arrangement of the image processing apparatus of the first embodiment;

FIG. 2 is a diagram which illustrates the transformation coefficient of 8×8 pixels;

FIG. 3 is a flowchart which illustrates the procedure for the operation of adding a brightness level in the image processing apparatus in the first embodiment;

FIG. 4 is a block diagram which illustrates the arrangement of the second embodiment;

FIGS. 5A and 5B are explanatory diagrams which illustrate the gain control and the DC level control;

FIGS. 6A-6E are explanatory diagrams which illustrate the designated zone of the zone designation switch 48;

FIG. 7 is a block diagram which illustrates the arrangement of the third embodiment;

FIG. 8 is a flowchart which illustrates the operation of the third embodiment;

FIG. 9 is a block diagram of the arrangement in an electronic camera;

FIG. 10 is a block diagram of the arrangement of the fourth embodiment;

FIG. 11 is a flowchart which illustrates the operation of the fourth embodiment;

FIG. 12 is a block diagram of the arrangement of the fifth embodiment;

FIG. 13 is a flowchart which illustrates the operation of the fifth embodiment;

FIG. 14 is a block diagram of the sixth embodiment;

FIG. 15 is a flowchart which illustrates the AE of the sixth embodiment;

FIG. 16 is another flowchart which illustrates the AE of the sixth embodiment;

FIG. 17 is a block diagram of the seventh embodiment;

FIG. 18 is a flowchart of the AE of the seventh embodiment;

FIG. 19 is a block diagram which illustrates the arrangement of the conventional electronic camera;

FIG. 20 is a block diagram which illustrates an example of the concrete arrangement of the conventional gain adjustment; and

FIG. 21 is a block diagram illustrating the arrangement which performs the conventional AE control.

### DESCRIPTION OF THE PREFERRED EMBODIMENTS

Preferred embodiments of the present invention will now be described in detail in accordance with the accompanying drawings.

[First Embodiment]

FIG. 1 is a block diagram which illustrates the arrangement of the image processing apparatus of the first embodiment. In the diagram, a video signal is inputted into the A/D converter 16. The signal is then converted to the digital signal and stored in the image memory 18. The discrete cosine transform (DCT) operation is performed on the digital signal, which was stored in the image memory 18, in the orthogonal transformer 104. Then, the signal which was stored in the memory 18 is inputted into the adder 105 after the DCT operation has been performed.

The system controller 100 comprising a CPU, ROM, and RAM inputs a brightness level, which is impressed from the outside, to the adder 105. The adder 105 adds the brightness level which was inputted from the system controller 100 to a DC component of a transformation coefficient obtained by the DCT, and then, outputs the DCT coefficient, including

the brightness level. The quantizer **106** quantizes the DCT coefficient and the quantized coefficient is coded by the coder **107**. Thus, the coded output including the brightness level is obtained. In this arrangement, the image compressing section **20** is comprised of the quantizer **106** and the coder **107**.

In general, in the case where the 2-dimensional DCT is performed on image data  $f(i, j)$  of the  $N \times N$  pixels, the transformation coefficient  $F(u, v)$  is expressed in the following equation (1):

$$F(u, v) = \frac{4C(u) \cdot C(v)}{N \cdot N} \sum_{i=0}^{N-1} \sum_{j=0}^{N-1} f(i, j) \times \cos\{(2i+1) \cdot u \cdot \pi/2N\} \cdot \cos\{(2j+1) \cdot v \cdot \pi/2N\}$$
 (1)

The “u” and “v” correspond respectively to spatial frequency of the x- and y-direction in two dimensions and  $C(u) \cdot C(v)$  is expressed in the following equations (2):

$$C(u) \cdot C(v) = 1/\sqrt{2} \quad (\text{when } u \cdot v = 0)$$
 (2)

$$C(u) \cdot C(v) = 1 \quad (\text{when } u \cdot v \neq 0)$$

For example, in the case of  $N=8$ , the transformation coefficients of  $8 \times 8$  pixels are as shown in FIG. 2. In the diagram,  $Y_{00}$  is a component of the frequency “0” and corresponds to the coefficient of a DC component and an average of  $8 \times 8$  pixels. The  $Y_{00} - Y_{07}$  of the first row represent the coefficients of spatial frequency components in the horizontal direction. The spatial frequency becomes higher from the left to the right. Therefore, the coefficient  $Y_{07}$ , which is located at the first row, in the far right (the eighth) column, corresponds to the coefficient of the highest spatial frequency in the horizontal direction. On the other hand, the  $Y_{10} - Y_{70}$  of the left (the first) column represent the coefficients of spatial frequency component in the vertical direction. The spatial frequency increases from the top to the bottom. Therefore, the coefficient  $Y_{70}$ , which is located at the bottom (eighth) row, the first column, corresponds to the coefficient of highest spatial frequency in the vertical direction.

Next, the procedure for the adding operation of a brightness level in the image processing apparatus is described.

FIG. 3 is a flowchart which illustrates the procedure for the brightness level adding operation in the image processing apparatus of the first embodiment. In step **S11**, a video signal is converted to a digital signal by the A/D converter. In step **S12**, the number of pixels to be transformed by the DCT is determined. It is supposed that the number of pixels to be transformed is  $8 \times 8$  pixels in the present embodiment. In step **S13**, according to the number of the transformation pixels, determined in step **S12**, the DCT is performed on the video signal which was converted to the digital signal. In step **S14**, the brightness level, inputted in the system controller **100**, is added to the DC component of the transformation coefficient, obtained by the DCT in step **S13**, and the DCT coefficient including the brightness level is outputted. Then, in step **S15**, it is examined whether or not the addition of the brightness level to a predetermined amount of the video signal has been completed.

If the result of the examination in step **S15** is YES, the process of adding the brightness level is completed, while if the result is NO, the process returns to step **S13** where the DCT is performed on the video signal to be converted next.

As described above, according to the image compressing apparatus of the present embodiment, since the number of converting pixels is predetermined to be  $8 \times 8$  pixels, the result obtained by adding the brightness level to the coef-

ficient of the DC component after the DCT brings the same result obtained when the DCT is performed after the brightness level, is added to the average of  $8 \times 8$  pixels. Therefore, the number of processes in which the brightness level is added is reduced to  $1/(8 \times 8)$  of the conventional processing which adds the brightness level to each pixel.

In the accordance with the present embodiment, by adjusting a brightness level in a manner such that the brightness level is added to the DC component coefficient of the DCT output, the number of adding processes for the brightness level can be reduced in proportion to the number of converted pixels, and consequently, high-speed processing can be performed.

Furthermore, along with the reduction of the number of the processes, a buffer quantity which relates to the adding processing can be also reduced, therefore, the apparatus can be simplified.

Furthermore, in the above embodiment, the DCT is used as an orthogonal transformation, however, other types of orthogonal transformation, e.g. a Hadamard transformation, can be applied to attain the same result. In addition, the number of converting pixels was predetermined as  $8 \times 8$  pixels in the present embodiment, however, other settings may be used.

Still further, in the above embodiment, the addition of brightness level was performed on the coder side, however, the addition on the modem side also brings the same effects. [Second Embodiment]

FIG. 4 is a block diagram which illustrates the arrangement of the second embodiment. The reference numeral **130** is an input terminal of an analog video signal to be compressed, the numeral **14a** is a VCA, the numeral **14b** is a clamping circuit, the numeral **16** is an A/D converter, the numeral **18** is a memory, the numeral **104** is an orthogonal transformer, the numeral **20** is an image compressor, and the numeral **144** is an output terminal for the coded data.

The numeral **100** is a system controller which searches for the white and black peaks from the DC component of the output from the orthogonal transformer **104** and controls the gain of the VCA **14a** and clamping level of the clamping circuit **14b**. The reference numeral **148** is a zone designation switch which designates an operation range of white and black peak levels by the system controller **100**. The zone can be selectively designated as “whole”, “center”, and “manual”.

The operation according to the second embodiment is now described in the case where the two-dimensional DCT is performed by the orthogonal transformer **104**. In the present embodiment, the gain control of the VCA **14a** and the clamping level control of the clamping circuit **14b** are performed as follows.

The two-dimensional DCT in the orthogonal transformer **104** is the same as that of the first embodiment.

In the second embodiment, the system controller **100** searches for the white and black peak levels from a coefficient of the DC component which is outputted from the orthogonal transformer **104**. In this way, the white and black levels can be obtained such that the influence of any impulse noise is removed.

The system controller **100** also obtains the white and black peak levels from the output of the orthogonal transformer **104** on the whole screen (FIG. 6C), the central area of the screen (FIG. 6D), and the area which was designated by manual selection (FIG. 6E).

According to the present embodiment, although an input signal of the input terminal **130** by the VCA **14a** is amplified, an attenuation circuit also may be utilized for level adjustment. In addition, in the present embodiment, the gain

control and DC level control are performed prior to the A/D conversion, however, the control can be performed after the A/D conversion with the same results. Furthermore, the orthogonal transformation of the orthogonal transformer **104** can be replaced, i.e. by the Hadamard transformation, rather than the DCT. The present invention can be further applied to the method which does not fix an orthogonal transformation unit as N×N pixels and changes the number of pixels according to a noise level.

As easily understood from the above-described second embodiment of the present invention, the gain and DC level can be controlled without being susceptible to the impulse noise. Therefore, a dynamic range of the A/D converter can be effectively utilized regardless of the quantity of noise. [Third Embodiment]

FIG. 7 is a block diagram which illustrates the components of the third embodiment. The reference numeral **230** is an input terminal for the image signal to be processed and the numeral **16** is an A/D converter which digitizes the image signal from the input terminal **230**. The numeral **134** is a recursive type noise reducing circuit comprising the coefficient circuit of the coefficient (1-K) **136**, the adding circuit **138**, the image memory **18** as a delay circuit for a screen, and the coefficient circuit of the coefficient (K) **142**. The reference numeral **104** is an orthogonal transformer of the DCT which is similar to the one in the first embodiment and the numeral **106** is a quantizer which quantizes the output coefficient of the orthogonal transformer **104**. The reference numeral **107** is a coder which encodes the output of the quantizer **106** and the numeral **150** is an output terminal for the code obtained by the coder **107**.

The numeral **100** is a system controller comprising a CPU, ROM, and RAM which controls the coefficients (1-K) and (K) of the coefficient circuits **136** and **142** in the noise reducing circuit **134** according to the output of the orthogonal transformer **104** (the coefficient of the DC component in particular). The numeral **34** is an operation section where a user inputs an instruction to the system controller **100** and the numeral **36** is a display which displays a state of operation and the like.

The flowchart illustrating the operation according to the third embodiment is shown in FIG. 8. Referring to FIG. 8, the operation is now described.

When an image signal which was inputted from the outside into the input terminal **230** is to be stored in the image memory **18**, a variable n representing how many times image data has been stored into the image memory **18** is set to "1" by the system controller **100** and the corresponding coefficients (1-K) and K are determined. For example:

$$K=1-1/n$$

$$1-K=1/n$$

The output of the A/D converter **16** is multiplied by (1-K) by the coefficient circuit **136** and impressed to the adding circuit **138**. The coefficient circuit **142** multiplies the output of the image memory **18** by K and impresses it to the adding circuit **138**. The adding circuit **138** adds the outputs of the coefficient circuits **136** and **142** and supplies them to the image memory **18**. Since at the first time (n=1), k=0, the output of the A/D converter **16** is written in the image memory **18** as it is (S22).

The orthogonal transformer **104** transforms the image by means of the DCT, which is stored in the image memory **18**, and the transformation coefficient shown in FIG. 2 is output. The system controller **100** picks up and reads the coefficients

of the high frequency components of the outputs of the orthogonal transformer **104** in the pattern as shown in FIG. 6 and removes the values of the peaks. Then the average of the absolute values is obtained (S23). The coefficients of the high frequency component are, for example,  $Y_{60}-Y_{66}-Y_{06}$ ,  $Y_{70}-Y_{77}-Y_{07}$  in FIG. 2. FIG. 6C shows the whole screen, FIG. 6D shows the central area of the screen, and FIG. 6E shows the area which is designated by manual selection in which the user selectively designates one area. In a way of accommodating the selecting means, noise in a predetermined area is detected and S/N ratio can be improved according to the result of detection.

In the case where the average of the absolute values of the coefficients of the high frequency component is over the predetermined value (S24), the system controller **100** increases the variation n and obtains the corresponding coefficients (1-K) and (K) (S25). Then, noise reduction is performed on the output of the A/D converter **16** which is taken into the image memory **18**.

In the case where the average of the absolute values of the coefficients of the high frequency component is less than the predetermined value (S24), the system controller **100** displays the completion of storage to the image memory **18** and completes the noise reduction. After that, the orthogonal transformation coefficient of the image which is stored in the image memory **18** is quantized and coded.

In short, according to the present embodiment, the amount of the high frequency component is examined by the orthogonal transformation coefficient. In the case where the high frequency component is over a predetermined amount, it is diagnosed that a considerable amount of noise is included and the amount of noise is reduced in a manner such that a larger area of the image is averaged. In the recursive type noise reduction, if the number of adding operation is n, the S/N ratio is improved by as much as  $n^{1/2}$  times as that of the conventional S/N ratio.

The block diagram of the arrangement in the case of applying the present invention to a video camera, or an electronic still camera is shown in FIG. 9. Some of the reference numerals designate the same or similar parts in both in FIGS. 7 and 9. The reference numeral **10** is a lens unit internally comprising a photographic lens, a shutter, and a diaphragm. The numeral **12** is a CCD image pickup device which converts the picture to an electrical signal by the lens unit **10**. The numeral **14** is an image pickup processing circuit which performs signal processing, e.g. a gamma correction, on the output of the image pickup device **12**, and outputs the standard type video signal. The image pickup processing circuit **14** further adjusts the gain so that the white and black peak levels will be within the predetermined range. The numeral **30** is a shutter drive circuit which drives a shutter of the lens unit **10** and the numeral **32** is a lens drive circuit which drives a focusing lens and zooming lens in the lens unit **10**. In addition to the above described functions, the system controller **100** controls functions including the aperture of the lens unit and shutter, focusing lens, and zooming lens, through the shutter drive circuit **30** and the lens drive circuit **32**.

In the present embodiment, the orthogonal transformer **104** performs the DCT, however, it can be replaced by the Hadamard transformation. Furthermore, the unit of the orthogonal transformer may be other than fixed as N×N pixels and the method which changes the unit according to a noise level can be utilized.

As easily understood from the above described third embodiment, according to the present invention, a highly efficient compression can be realized as well as an improvement of the S/N ratio.

In other words, a quantity of noise can be estimated from the amount of high frequency component of the image to be compressed which can be obtained from the orthogonal transformation coefficient. In the case where a considerable amount of noise is included, the noise reduction level is increased by the noise reduction means. On the other hand, in the case where an amount of noise is little, the noise reducing level is decreased. In this way, an image in which the S/N ratio is over a predetermined value can still be obtained. The image data transformed by the orthogonal transformation, and quantized, and then coded. Thus, a high efficiency of compression is realized.

[Fourth Embodiment]

FIG. 10 is a block diagram of the arrangement of the fourth embodiment. Some of the reference numerals designate the same or similar parts both in FIGS. 9 and 10. In the present embodiment, the following are provided: the orthogonal transformer 104 which performs an orthogonal transformation on the output of the image memory 18, quantizer 106 which quantizes the orthogonal transformation coefficient by the orthogonal transformer 104, and coder 107 which codes the output of the quantizer 106. When the image data for a screen is stored in the image memory 18, the image data of the image memory 18 is transformed by the orthogonal transformation (e.g. DCT) and the quantizer 106 quantizes the coefficient output by the orthogonal transformer 104. The output of the quantizer 106 is coded by the coder 107 and outputted to the outside through the output terminal 126. The output is either modulated or demodulated, if necessary, and recorded on a recording medium.

The feature of the present embodiment is that the quantity of noise of the image is calculated from the orthogonal transformation coefficient, particularly from the coefficient of the high frequency component, which is outputted from the orthogonal transformer 104, and a quantity of exposure of the image pickup device (CCD) 12 such as lens aperture and/or shutter open period is controlled. The system controller 100 further comprises the functions of controlling lens aperture and/or shutter.

The two-dimensional DCT in the orthogonal transformer is similar to that of the first embodiment.

Referring to the flowchart in FIG. 11, the operation of the characteristic part of the fourth embodiment is described. When started, after the output signal of the image pickup device 12 is processed by the image pickup processing circuit 14, it is digitized by the A/D converter 16, and then written in the image memory 18 (S31). The orthogonal transformation 104 performs the DCT on the image which will be stored in the image memory 18 and outputs the transformation coefficient shown in FIG. 2. The system controller 100 reads the coefficients of the frequency components of the output of the orthogonal transformer 104 by the pattern as shown in FIGS. 6A-6E, and removes the peak values, and then, obtains the average of the absolute values (S32). The coefficients of the high frequency components are, for example,  $Y_{70}-Y_{77}-Y_{07}$  in FIG. 2. FIG. 6C shows the whole screen, FIG. 6D shows the central area of the screen, and FIG. 6E shows the area which was designated by manual selection, and the user selectively designates one of these areas. By this selection, the user can get the optimum amount of exposure on a desired area.

In the case where the average of the absolute values of the coefficients of the high frequency components is over the predetermined value (S33), the system controller 100 either opens the lens aperture or slows down a shutter speed (S34). Then, the gain of the image pickup system is reduced for the

amount that the sensitivity of the image pickup section was increased (S35). Then, the image pickup signal is again stored into the image memory 18 (S31).

In the case where the average is less than the predetermined value (S33), the system controller 100 displays the completion of storage to the image memory 18 on the display 36 (S36). After that, the orthogonal transformation coefficient of the image which was stored in the image memory 18 is quantized and coded.

In short, according to the present embodiment, the amount of the high frequency component is examined by referring to the orthogonal transformation coefficient. In the case where the high frequency component is over a predetermined amount, it is diagnosed that a considerable quantity of noise is present. In the case where the noise is over the predetermined amount, the quantity of the exposure of the image pickup device 12 is increased. In the way, the noise caused by lack of exposure is considerably reduced.

In the present embodiment, the orthogonal transformation of the orthogonal transformer 104 is a discrete cosine transform (DCT), however, it can be replaced by the Hadamard transformation.

As easily understood from the described fourth embodiment, according to the present invention, since the pickup image in which the noise is lower than the predetermined amount is attained, a highly efficient compression is realized. Furthermore, the S/N ratio of the reproduced image will be over the above predetermined value and a fine quality reproduced image is obtained.

In other words, a quantity of noise which is included in the pickup image is estimated from the orthogonal transformation coefficient. In the case where the estimated noise quantity is a considerable amount, the quantity of exposure of the image pickup means is increased. That is, the lens aperture of optical system is opened and/or a shutter open period is extended. In this way, the noise of the pickup image is reduced and the compression efficiency is kept at over the predetermined rate in the coding means.

[Fifth Embodiment]

FIG. 12 is a block diagram of the arrangement of the fifth embodiment. Some of the reference numerals designate the same or similar parts both in FIGS. 10 and 12. In the present embodiment, the following are provided: the orthogonal transformer 104 which performs an orthogonal transformation on the output of the image memory 18, the quantizer 106 which quantizes the orthogonal transformation coefficient by the orthogonal transformer 104, and the coder 107 which codes the output of the quantizer 106. When the image data for a screen is stored in the image data memory 18, the orthogonal transformer 104 performs an orthogonal transformation (e.g. DCT) and the quantizer 106 quantizes the coefficient which was outputted by the orthogonal transformer 104. Then, the coder 107 encodes the output of the quantizer 106 and outputs the coded data through the output terminal 226. The output which was outputted to the outside is either modulated or demodulated, if necessary, and recorded on a recording medium.

The quantizer 106 is a circuit which controls a quantizing characteristic from the outside. The system controller 100 controls the quantizing characteristic according to the output of the orthogonal transformer 104.

The two-dimensional DCT of the orthogonal transformer 104 is similar to that of the first embodiment.

Referring to the flowchart in FIG. 13, the operation of the characteristic part of the fifth embodiment is described. When started, after the output signal of the image pickup device 12 is processed by the image pickup processing

circuit **14**, it is digitized by the A/D converter **16**, and then written in the image memory **18** (S41). The orthogonal transformer **104** transforms the image which is stored in the image memory **18** by the DCT transformation. The system controller **100** reads the coefficient ( $Y_{00}$  in FIG. 2) of the DC component in a screen by the pattern shown in FIGS. 6A-6E, which is outputted by the orthogonal transformer **104**, and obtains the integrated value of the DC component in the screen (S42). FIG. 6C is an area of the whole screen, FIG. 6D is an area of the central part of the screen, and FIG. 6E is an area which was designated by manual selection. A user can selectively designate one of these areas by the operation section **34**. By providing a selection means, noise in a desired area can be detected.

In the case where the integrated value of a DC component is less than a first predetermined value, for example 50% luminance level that represents 50% of the dynamic range of luminance (S43), the system controller **100** takes the coefficients of the high frequency components which are outputted from the orthogonal transformer **104** in a similar way to the pattern of the DC component and the average of the absolute values without the peak values is obtained (S44). The coefficients of the high frequency component are, for example,  $Y_{60}-Y_{66}-Y_{06}$  are  $Y_{70}-Y_{77}-Y_{07}$ . In the case where the integrated value is over a second predetermined value, for example 60% luminance level (S45), the characteristics of quantization are set so that the peak values are removed and the coefficients of the high frequency components which are over the predetermined value are reduced, or set as a non-signal (S46). The quantizer **106** quantizes the output of the orthogonal transformer **104**, and the coder **107** encodes the output of the quantizer **106** (S47).

After quantization and coding, the completion of an image compression is displayed on the display **36** (S48).

In short, according to the present embodiment, in the case where the image level is relatively low and the high frequency energy of the image is a considerable amount, the level of the high frequency component is reduced or quantization is performed by regarding the signal as a non-signal. As a result, the S/N ratio and efficiency of compression are both improved.

In the present embodiment, the orthogonal transformer **104** performs the DCT, however, it can be replaced by the Hadamard transformation. The present invention can also be applied to a line input by a CCD line sensor other than the compression of the image pickup by the image pickup device. The unit of the orthogonal transformation may be other than fixed as  $N \times N$  and a method which changes the unit according to noise level can be utilized. Furthermore, for quantization, it can be set so that a matrix can be selected according to DC and AC components of the orthogonal transformation.

As easily understood from the above described embodiment, both an S/N ratio and efficiency of compression can be improved in a manner such that quantization is performed according to the characteristic of the state of the image to be compressed.

In other words, according to the present invention, the amounts of the DC component and high frequency component of the image to be compressed can be estimated from the output of the orthogonal transformation means. For example, in the case where the DC component is less than the predetermined value and the high frequency component is over the predetermined value, the characteristic of the quantization means is changed and controlled so that the coefficient of the high frequency component is reduced or set to "0". In this way, a high efficiency of compression is achieved and the S/N ratio is also improved.

[Sixth Embodiment]

FIG. 14 is a block diagram of the image pickup apparatus according to the sixth embodiment. As shown in the diagram, an image is converted to the electric signal by the lens unit **10** and the CCD **12**, and further converted to the video signal by the image pickup processing circuit **14**. Then, the video signal is converted to the digital signal by the A/D converter and the image data is compressed by the image data compression section **20**, and then the coded output **306** is outputted. This is an orthogonal transformation, compression method which utilizes a two-dimensional DCT, one type of orthogonal transformation. The output of the A/D converter **16** is stored in the image memory **18** for a screen and the DCT is performed in the DCT section, orthogonal transformer **104**, by using the  $8 \times 8$  pixel data from the image memory **18**.

The orthogonal transformation is a two-dimensional DCT which is similar to that of the first embodiment.

Each element of the  $8 \times 8$  coefficient matrix  $F(u, v)$  respectively corresponds to the transformation coefficients of the frequency components which are  $u/2N$  times and  $v/2N$  times the highest frequency component. As shown in FIG. 2,  $Y_{00}$  corresponds to the component of high frequency "0", that is, the coefficient of DC component which is the average of the  $8 \times 8$  pixels. The first row corresponds to the coefficients of the spatial frequency to the horizontal direction of the image. The  $Y_{07}$  in the far right column corresponds to the highest coefficient of the spatial frequency component in the horizontal direction. The left column (the first column) corresponds to the coefficients of the spatial frequency to the vertical direction.  $Y_{70}$  which is located at the first column, the bottom (eighth) row corresponds to the highest coefficient of the spatial frequency component in the vertical direction. The output of the orthogonal transformer **104** is transferred to the SQ linear coder, quantizer **106**. The coefficient  $Y_{00}$  of the DC component is transformed to the one dimensional predicted code. The coefficients of the DC components except  $Y_{00}$  are zigzag-scanned, and further transformed into the variable-length codes by the VLC fixed Huffman coder **107** and the coded output **306** is obtained.

The present embodiment is described along with the AE flowchart in FIG. 15. When an AE is started, an image is taken into the image memory **18** through the image pickup processing circuit **14** and the A/D converter **16** (S301). Then, the image data is inputted to the orthogonal transformer **104** from the image memory **18** in the pattern as shown in FIGS. 6A-6E and the coefficient  $Y_{00}$  of the DC component of the output of the orthogonal transformer **104** is taken into the system controller **100** (S302). The system controller **100** integrates the coefficient  $Y_{00}$  of the DC component (S303) and examines whether or not the integrated value is within the predetermined range (S304). In the case where the value is within the predetermined range (S304, YES), the completion of AE is displayed on the display **36** by the system controller **100** when the AE is completed (S308).

In the case where the integrated value is out of the predetermined range (S304, NO), which did not reach the predetermined level (S305, less), either the iris is expanded  $n$  steps or the shutter open period is extended by  $n\mu s$  (S306). On the other hand, in the case where the value is larger than the predetermined level (S305, larger), the iris is narrowed  $n$  steps or the shutter open period is shortened by  $n\mu s$  (S306). Then, the process proceeds to step S301 and the loop is repeated until the integrated value is within the predetermined level range.

As described above, the coefficient  $Y_{00}$  of the orthogonal transformer **104** corresponds to the average of the  $8 \times 8$

pixels. The AE can be controlled so that the light quantity of the input of the CCD 12 becomes optimum by controlling the iris and the shutter open period so that the integrated value becomes optimum by integrating the average in the system controller 100. This operation can be performed on the image in which the outputs of the CCD 12 are appropriately picked up.

FIGS. 6A–6E illustrate the “pick-up pattern” from the screen. FIG. 6A is pick-up from the whole screen, FIG. 6B is pick-up mainly from the central area, FIG. 6C is pick-up of every 8×8 pixels from the whole screen, and FIG. 6D is pick-up of every 8×8 pixels mainly from the central area of the screen. Thus, the weight of photometry is controlled by the density of sample points.

Furthermore, according to present embodiment, although a band compression is performed by the DCT, another orthogonal transformation method such as Hadamard transformation can obtain a similar result.

Then, another example of the AE operation is described in connection with the flowchart shown in FIG. 16. The whole arrangement is similar to that of FIG. 14.

The object of the present embodiment is to shorten the time required to complete the AE. First, the AE, the  $n$  steps iris correction or  $n\mu s$  shutter open period correction ( $N \geq 2$ ) (S501), is performed. Then, whether or not the integrated value of  $Y_{00}$  is within the first level is examined in the system controller 100 (e.g.  $60 \pm 20\%$  to the whole 100%). In the case where the value is out of the range (S502, NO), steps S501 and S502 are repeated until the value reaches the first level. When the value reaches the first level (S502, YES), whether or not the value is within the second level (e.g.  $65 \pm 10\%$ ). In the case where the value is within the second level (S503, YES), the completion of the AE is displayed on the display 36 (S505) when the AE is completed. In the case where the value is out of the range (S503, NO), the AE control performs a 1 step iris change or  $\mu s$  shutter open period correction until the value reaches the second level (S504).

The AE such as  $n$  step iris change or  $n\mu s$  shutter open period correction means that the AE is controlled in a manner such that the iris drive is changed every  $n$  step or the shutter open period is changed every  $n\mu s$  as shown in FIG. 15.

Furthermore, the AE such as  $n$  step iris change or  $n\mu s$  shutter open period correction means that the iris drive is changed step by step or a shutter open period is corrected every  $\mu s$ .

As described above, in the present embodiment, in the case where the shift of the AE level is quite large, the iris or shutter open period is changed a considerable amount. In the case where the shift is small, the iris or shutter open period is changed only a little. Thus, the time for completion of the AE is shortened and the AE can be performed accurately. [Seventh Embodiment]

FIG. 17 illustrates the arrangement of the seventh embodiment. As shown in the diagram, the difference between the sixth and seventh embodiment is that the data of the system controller 100 can be inputted to the orthogonal transformer 104. The present embodiment is described with the accompanying AE flowchart in FIG. 18. First, an image is taken into the image memory 18 from the CCD 12 through the image pickup processing circuit 14 and A/D converter 16 (S701). Then, the image data is inputted to the orthogonal transformer 104 from the image memory 18 by the “pick-up pattern” as shown in FIGS. 6A–6E (S702) and the coefficient  $Y_{00}$  of the DC component of the output from the orthogonal transformer 104 is taken into the system

controller 100 (S703). Then, whether or not the average of the picked up screen was obtained is examined. In the case where, the average has not obtained yet (S704, NO), the coefficient  $Y_{00}$  of the DC component which was taken into the system controller 100 is inputted as 8×8 data (64 data) into the orthogonal transformer 104 through the switch 321, and then the process proceeds to step S703.

When the average of the whole picked up screen is obtained (S704, YES), whether or not the average is within the predetermined range is examined. In the case where the average is within the range (S706, YES), the completion of AE is displayed on the display 36 by the system controller 100 (S710) when the AE is completed.

In the case where the average is out of the range (S707, less), which did not reach the predetermined level, either the iris is expanded  $n$  steps or the shutter open period is extended  $n\mu s$  (S708). On the other hand, in the case where the average is over the predetermined level (S707, over), the iris is narrowed  $n$  steps or shutter open period is shortened  $n\mu s$  (S709). Then, the process proceeds to step S701 and this operation is repeated until the average reaches the predetermined level range.

As described above, in the accordance with the present invention, the average of all pixels of the picked-up image is obtained by the orthogonal transformer 104 in a manner such that  $Y_{00}$ , the output of the orthogonal transformer 104, is once returned to the orthogonal transformer 104 through the system controller 100 by using the coefficient  $Y_{00}$  of the DC component of the orthogonal transformer 104 and becomes the average of the inputted 8×8 data. The AE is performed by controlling the iris and the shutter open period so that the average will be within the predetermined range.

Furthermore, as described above, according to the present invention which was shown in the sixth and seventh embodiments, the AE is performed in a manner such that the DC component of the image which is obtained during the image data compression processing is utilized, therefore, the LPF, A/D converter, and the integrator for obtaining the low-pass components for the AE are not necessary, and consequently the AE can be performed at a low price.

Furthermore, the present invention which was shown in the first through seventh embodiments can be applied to a system comprising either a single apparatus or a plurality of apparatuses. Needless to say that the present invention can be applied to the case where programs are supplied to the system or apparatus.

Because many apparently widely different embodiments of the present invention can be made without departing from the spirit and scope thereof, it is to be understood that the invention is not limited to the specific embodiments thereof except as defined in the claims.

What is claimed is:

1. An image processing apparatus comprising:

input means for inputting orthogonal-transformed image data;

arithmetic means for adding a predetermined value to transformation coefficients of the orthogonal-transformed image data inputted by said input means to change a brightness level of the inputted image data; and

encoding means for encoding the image data which comprises the transformation coefficients and the predetermined value added by said arithmetic means.

2. The apparatus according to claim 1, wherein said input means includes:

image pickup means for photographing an image and for converting the image into image data; and

image pickup adjusting means for adjusting said image pickup means based on the transformation coefficients.

3. The apparatus according to claim 1, wherein said input means includes transformation means for performing an orthogonal transformation on the inputted image data and for obtaining the transformation coefficients.

4. The apparatus according to claim 1, further comprising recording means for recording on a recording medium the image data encoded by said coding means.

5. The apparatus according to claim 1, wherein said arithmetic means adds a predetermined value to a coefficient of a DC component in the transformation coefficients, for performing brightness-level adjustment on the input image data.

6. An image processing method comprising the steps of: inputting orthogonal-transformed image data; adding a predetermined value to transformation coefficients of the orthogonal-transformed image data inputted at said inputting step to change a brightness level of the inputted image data; and

encoding the image data which comprises the transformation coefficients and the predetermined value added in said adding step.

7. A method according to claim 6, wherein said inputting step includes the steps of:

photographing an image and converting the image into image data; and

adjusting said photographing step based on the transformation coefficients.

8. A method according to claim 6, wherein said inputting step includes the step of performing an orthogonal transfor-

mation on the inputted image data and obtaining the transformation coefficients.

9. A method according to claim 6, further comprising the step of recording, on a recording medium, the image data encoded in the encoding step.

10. A method according to claim 6, wherein said adding step adds a predetermined value to a coefficient of a DC component in the transformation coefficients, for performing brightness-level adjustment on the input image data.

11. An image processing apparatus comprising:

input means for inputting orthogonal-transformed image data;

arithmetic means for adding a predetermined value to transformation coefficients of the orthogonal-transformed image data inputted by said input means to change a brightness level of the inputted image data; and

processing means for processing the brightness-changed orthogonal-transformed image data output from said arithmetic means.

12. An image processing method comprising the steps of: inputting orthogonal-transformed image data;

adding a predetermined value to transformation coefficients of the orthogonal-transformed image data inputted in said inputting step to change the brightness level of the inputted image data; and

processing the brightness-changed orthogonal-transformed image data output at said adding step.

\* \* \* \* \*

UNITED STATES PATENT AND TRADEMARK OFFICE  
**CERTIFICATE OF CORRECTION**

PATENT NO. : 5,838,379

DATED : November 17, 1998

INVENTOR(S) : MAKOTO TAKAYAMA

Page 1 of 2

It is certified that error appears in the above-identified patent and that said Letters Patent is hereby corrected as shown below:

COLUMN 1,

Line 49, "operation" should read --operations--.

COLUMN 2,

Line 17, "using" should read --in--; and

Line 18, "in" should read --using--.

COLUMN 3,

Line 16, "optimize" should read --so as to optimize--.

COLUMN 4,

Line 40, "concrete" should be deleted.

COLUMN 6,

Line 7, "In the" should read --In--.

COLUMN 7,

Line 49, "K" should read --(K)--; and

Line 61, "k=0," should read --K=0

COLUMN 8,

Line 20, "then" should read --than--; and

Line 34, "operation" should read --operations--.



UNITED STATES PATENT AND TRADEMARK OFFICE  
**CERTIFICATE OF CORRECTION**

PATENT NO. : 5,838,379

DATED : November 17, 1998

INVENTOR(S) : MAKOTO TAKAYAMA

Page 2 of 2

It is certified that error appears in the above-identified patent and that said Letters Patent is hereby corrected as shown below:

COLUMN 9,

Line 10, "data" should read --data is--.

COLUMN 10,

Line 17, "In the" should read --In this--.

COLUMN 11,

Line 23, "Y<sub>60</sub> - Y<sub>66</sub> - Y<sub>06</sub> are" should read --Y<sub>60</sub> - Y<sub>66</sub> - Y<sub>06</sub>, --.

COLUMN 12,

Line 26, "to" should read --in--;

Line 30, "to" should read --in--; (2nd occurrence)

Line 37, "one" should read --one- --.

COLUMN 13,

Line 31, before "whether" insert --it is determined--; and

Line 41, "step" should read --steps--.

COLUMN 14,

Line 3, "not" should read --not been--.

Signed and Sealed this

Twenty-first Day of September, 1999

Attest:

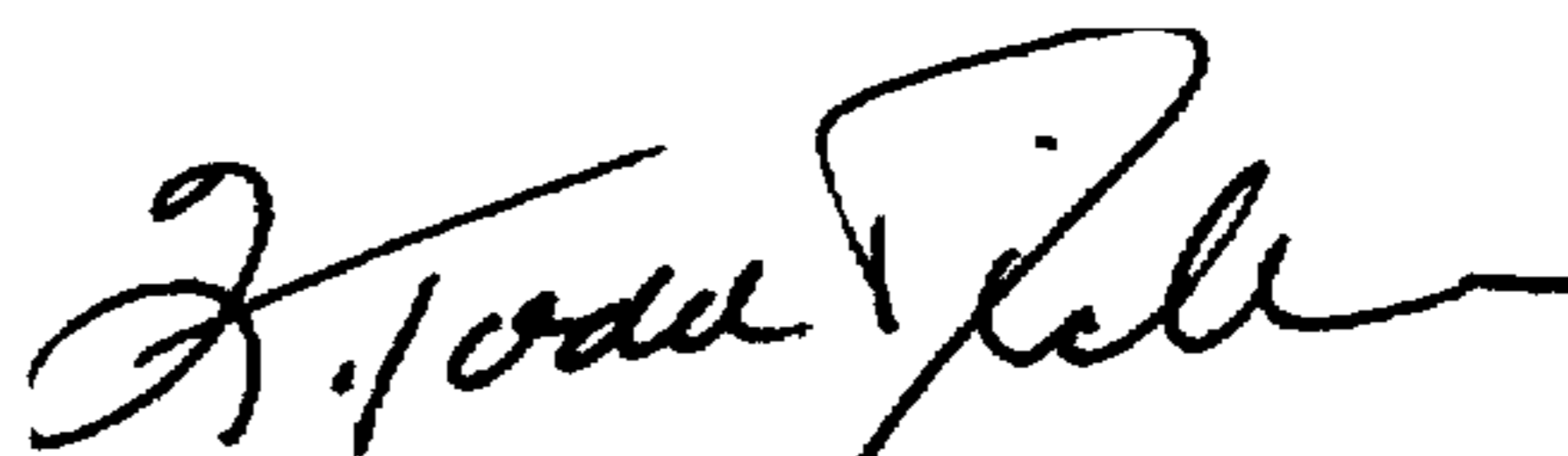

Q. TODD DICKINSON

Attesting Officer

Acting Commissioner of Patents and Trademarks