



US005818438A

# United States Patent [19]

[11] Patent Number: **5,818,438**

Howe et al.

[45] Date of Patent: **Oct. 6, 1998**

## [54] SYSTEM AND METHOD FOR PROVIDING TELEVISION SERVICES

[75] Inventors: **Wayne R. Howe**, Dublin, Ohio; **Fred Thomas Danner, III**, Alpharetta; **John R. Mauney**, Jefferson, both of Ga.

[73] Assignee: **BellSouth Corporation**, Atlanta, Ga.

[21] Appl. No.: **428,718**

[22] Filed: **Apr. 25, 1995**

[51] Int. Cl.<sup>6</sup> ..... **H04N 7/173**

[52] U.S. Cl. .... **345/327; 348/13; 455/4.2**

[58] Field of Search ..... 348/9, 6, 10, 12, 348/13, 14, 15, 16, 17, 18, 461, 463, 465, 468, 473, 478, 553, 563, 564, 565, 566; 455/5.1, 6.1, 6.2, 6.3, 4.2, 3.1; 395/200.47, 200.48, 200.49; 345/327; H04N 7/16, 7/173, 5/44, 5/445

5,173,900	12/1992	Miller et al. .	
5,191,645	3/1993	Carlucci et al. .	
5,208,665	5/1993	McCalley et al. .	
5,247,347	9/1993	Litteral et al. .	
5,249,044	9/1993	Von Kohorn .	
5,287,181	2/1994	Holman .	
5,335,277	8/1994	Harvey et al. .	
5,339,315	8/1994	Maeda et al. ....	348/7
5,343,240	8/1994	Yu .	
5,357,276	10/1994	Banker et al. ....	348/7
5,374,951	12/1994	Welsh .	
5,404,393	4/1995	Remillard .	
5,446,490	8/1995	Blahut et al. ....	348/7
5,483,277	1/1996	Granger .	
5,502,499	3/1996	Birch et al. .	
5,585,838	12/1996	Lawler et al. ....	348/906
5,608,448	3/1997	Smoral et al. ....	348/7

*Primary Examiner*—Chris Grant  
*Attorney, Agent, or Firm*—Marcus Delgado, Esq.; James L. Ewing, IV, Esq.; Kilpatrick Stockton LLP

## [56] References Cited

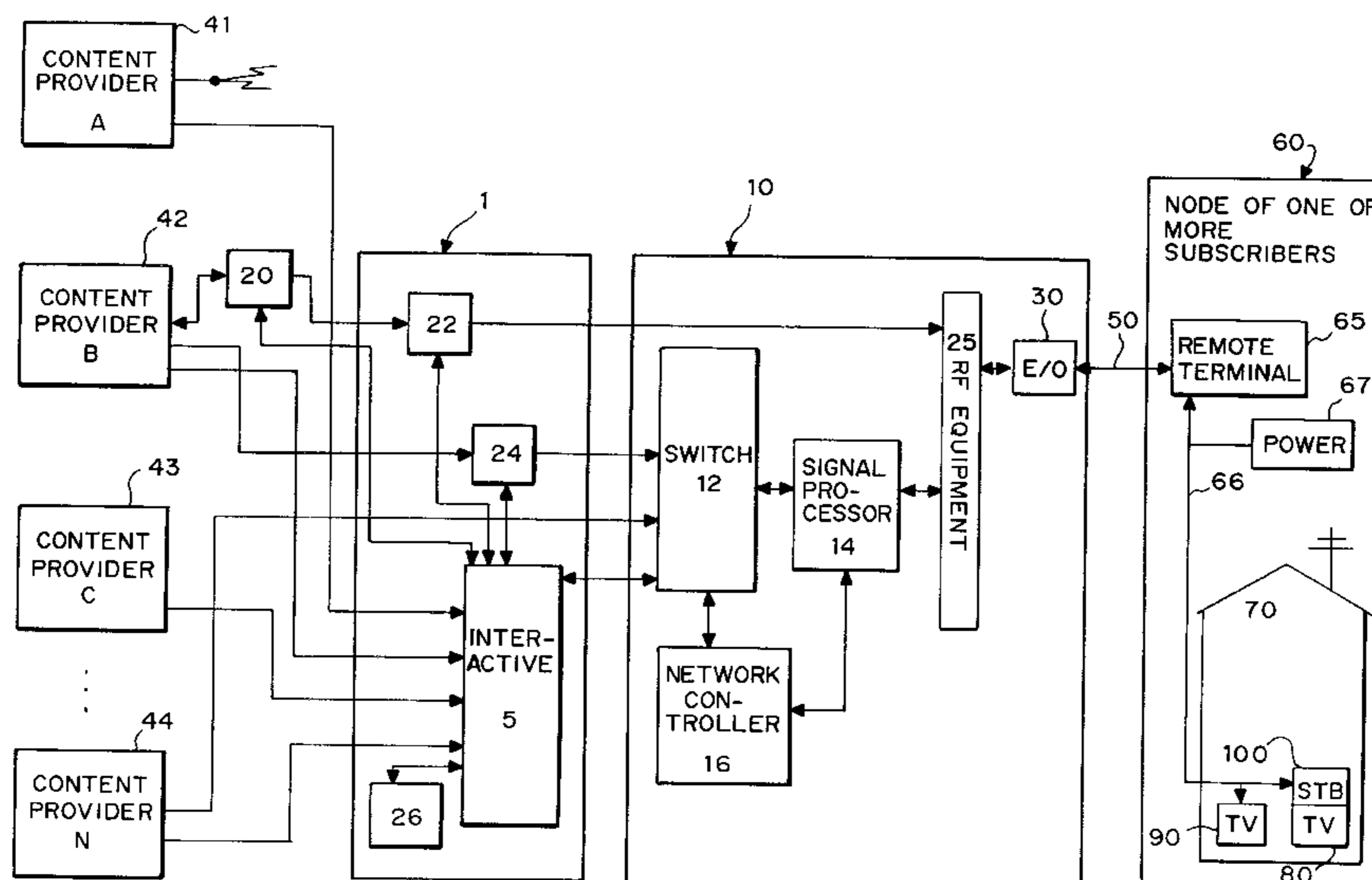
### U.S. PATENT DOCUMENTS

3,798,610	3/1974	Bliss et al. .
3,886,302	5/1975	Kosco .
4,130,833	12/1978	Chomet .
4,258,386	3/1981	Cheung .
4,361,851	11/1982	Asip et al. .
4,488,179	12/1984	Kruger et al. .
4,566,030	1/1986	Nickerson et al. .
4,567,591	1/1986	Gray et al. .
4,598,288	7/1986	Yarbrough et al. .
4,688,248	8/1987	Tomizawa .
4,689,661	8/1987	Barbieri et al. .
4,698,670	10/1987	Matty .
4,720,873	1/1988	Goodman et al. .
4,816,904	3/1989	McKenna et al. .
4,890,322	12/1989	Russell, Jr. .
4,912,552	3/1990	Allison, III et al. .
5,010,585	4/1991	Garcia .
5,046,090	9/1991	Walker et al. .
5,046,092	9/1991	Walker et al. .
5,055,924	10/1991	Skutta .

## [57] ABSTRACT

A system and method are described for providing interactive television services and for switching between television programs, such as to an interactive program session from another program. An interactive server, capable of providing requested interactive video services to a set of subscribers in a given geographic area, is coupled to a network to which subscriber set top boxes are also coupled. Television programming, which may be furnished by any number of sources, is accompanied by a signal that indicates the availability of other programming, such as interactive television service related to the program being viewed, as well as information to be used in requesting such service. The user, when notified by this signal, may input to the set top box a request for a second program, such as an interactive program or application. The identity of the original program channel is stored, and a session with the video service provider is established over the network. When the session is terminated, the set top box re-tunes the television signal to the original program channel.

**40 Claims, 16 Drawing Sheets**



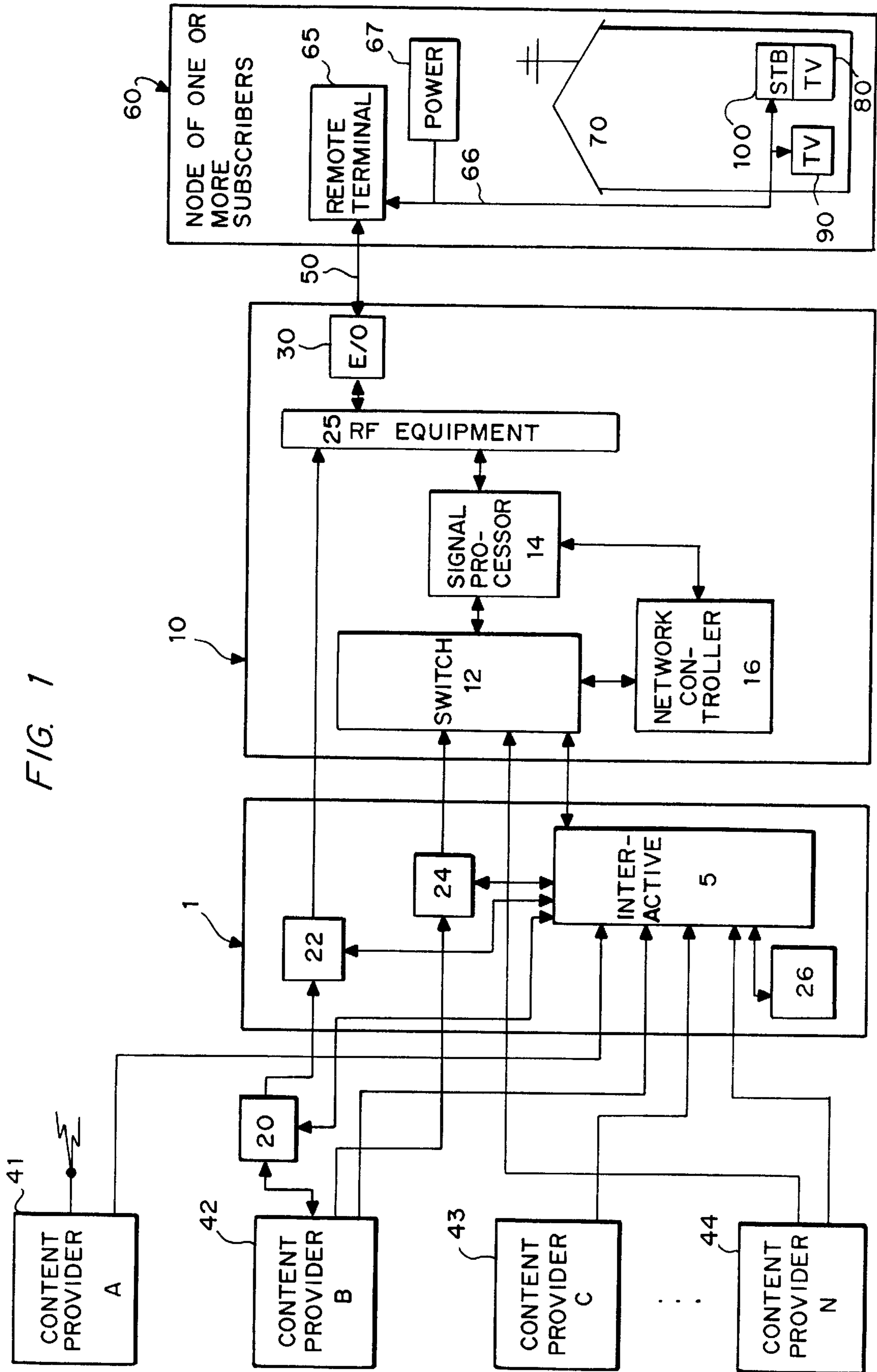


FIG. 1

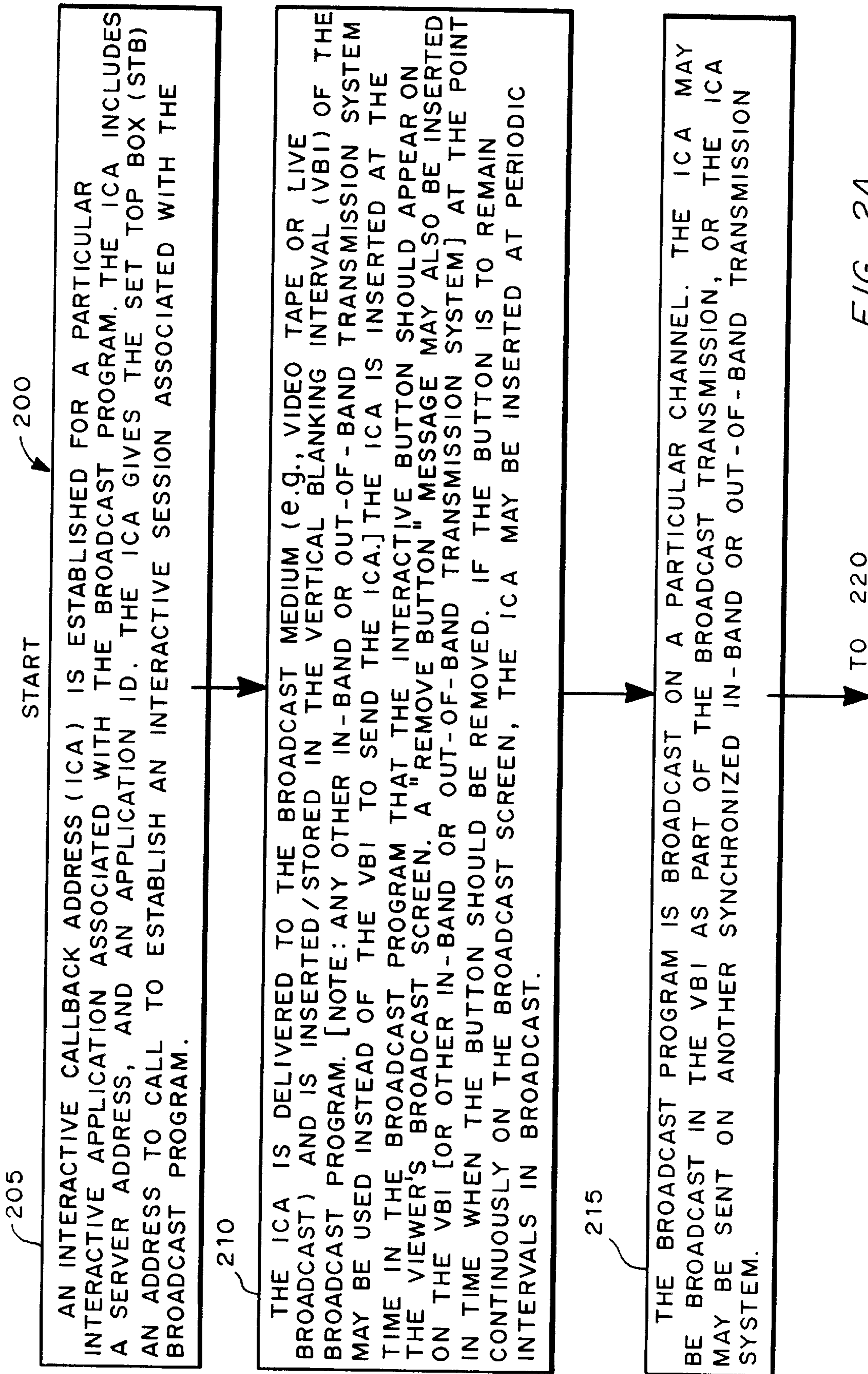
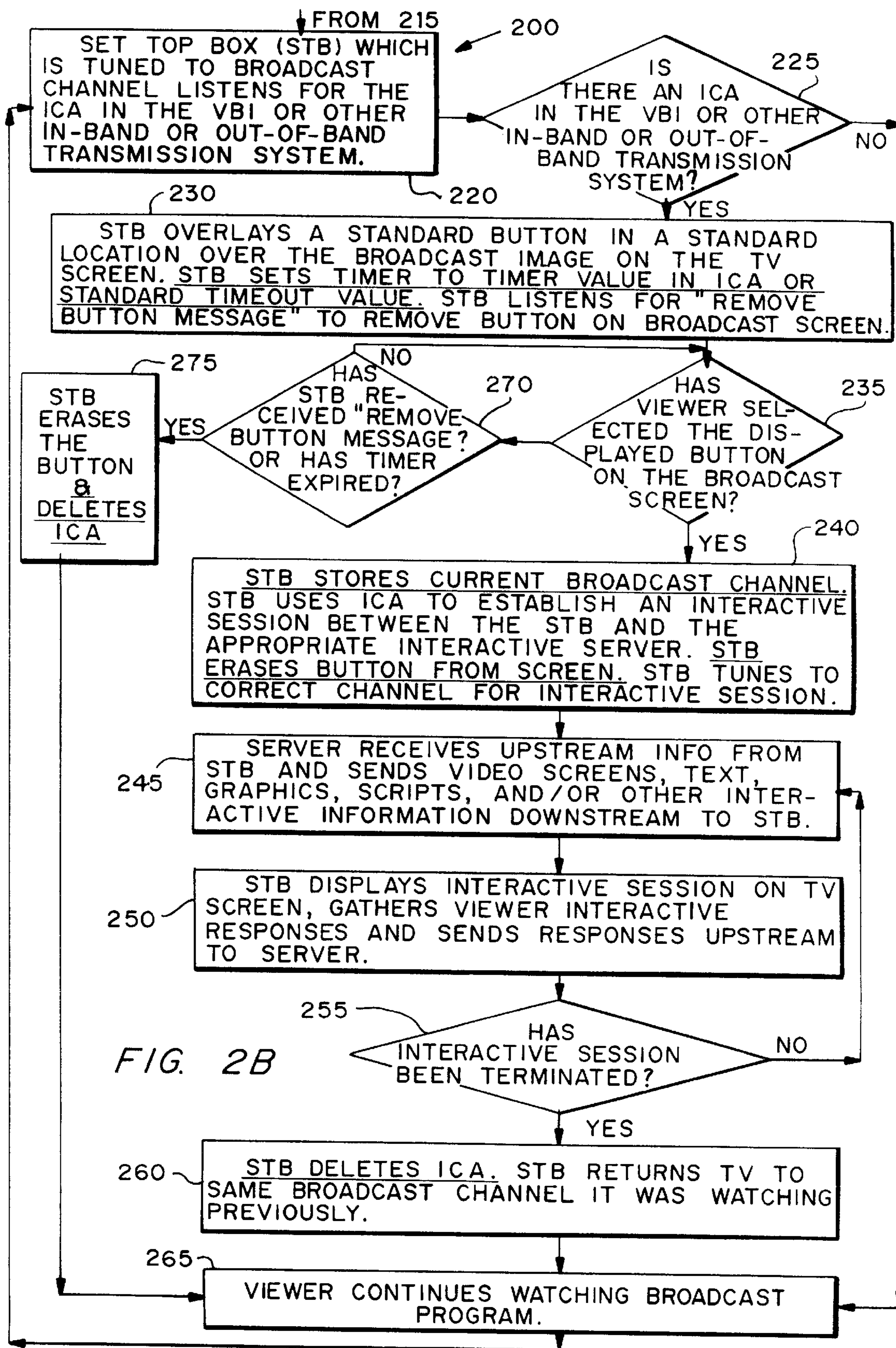


FIG. 2A



START

305

300

AN INTERACTIVE CALLBACK ADDRESS (ICA) IS ESTABLISHED FOR A PARTICULAR INTERACTIVE APPLICATION ASSOCIATED WITH THE BROADCAST PROGRAM. A WELL KNOWN INTERACTIVE CALLBACK ADDRESS (WKICA) IS ESTABLISHED FOR ALL INTERACTIVE APPLICATIONS ASSOCIATED WITH ALL BROADCAST PROGRAMS. BOTH THE ICA AND THE WKICA INCLUDE A SERVER ADDRESS, AND AN APPLICATION ID. THE WKICA GIVES THE SET TOP BOX (STB) A COMMON ADDRESS FOR ALL STBS TO CALL (SORT OF LIKE AN 800 NUMBER) TO GET THE ICA INFORMATION ASSOCIATED WITH THEIR PARTICULAR INTERACTIVE APPLICATION. THEN THE STB CALLS THE PARTICULAR ICA TO ESTABLISH THE PARTICULAR INTERACTIVE SESSION ASSOCIATED WITH THE BROADCAST PROGRAM.

310

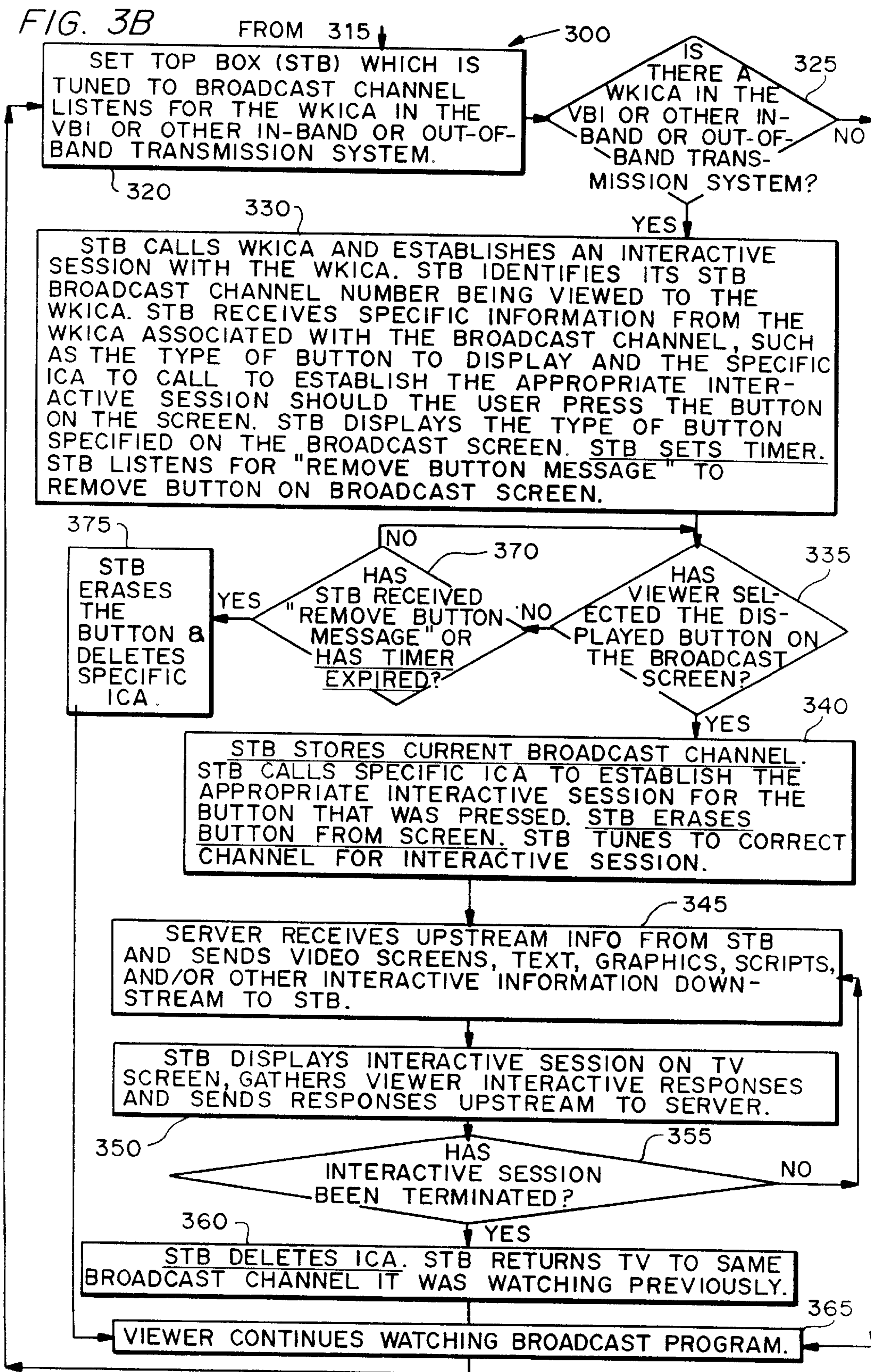
THE WKICA IS DELIVERED TO THE BROADCAST MEDIUM (E.G., VIDEO TAPE OR LIVE BROADCAST) AND IS INSERTED/STORED IN THE VERTICAL BLANKING INTERVAL (VBI) OF THE BROADCAST PROGRAM. [NOTE: ANY OTHER IN-BAND OR OUT-OF-BAND TRANSMISSION SYSTEM MAY BE USED INSTEAD OF THE VBI TO SEND THE WKICA.] THE WKICA IS INSERTED AT THE TIME IN THE BROADCAST PROGRAM THAT THE INTERACTIVE BUTTON SHOULD APPEAR ON THE VIEWER'S BROADCAST SCREEN. A "REMOVE BUTTON" MESSAGE MAY ALSO BE INSERTED ON THE VBI [OR OTHER IN-BAND OR OUT-OF-BAND TRANSMISSION SYSTEM] AT THE POINT IN TIME WHEN THE BUTTON SHOULD BE REMOVED. IF THE BUTTON IS TO REMAIN CONTINUOUSLY ON THE BROADCAST SCREEN, THE WKICA MAY BE INSERTED AT PERIODIC INTERVALS IN BROADCAST.

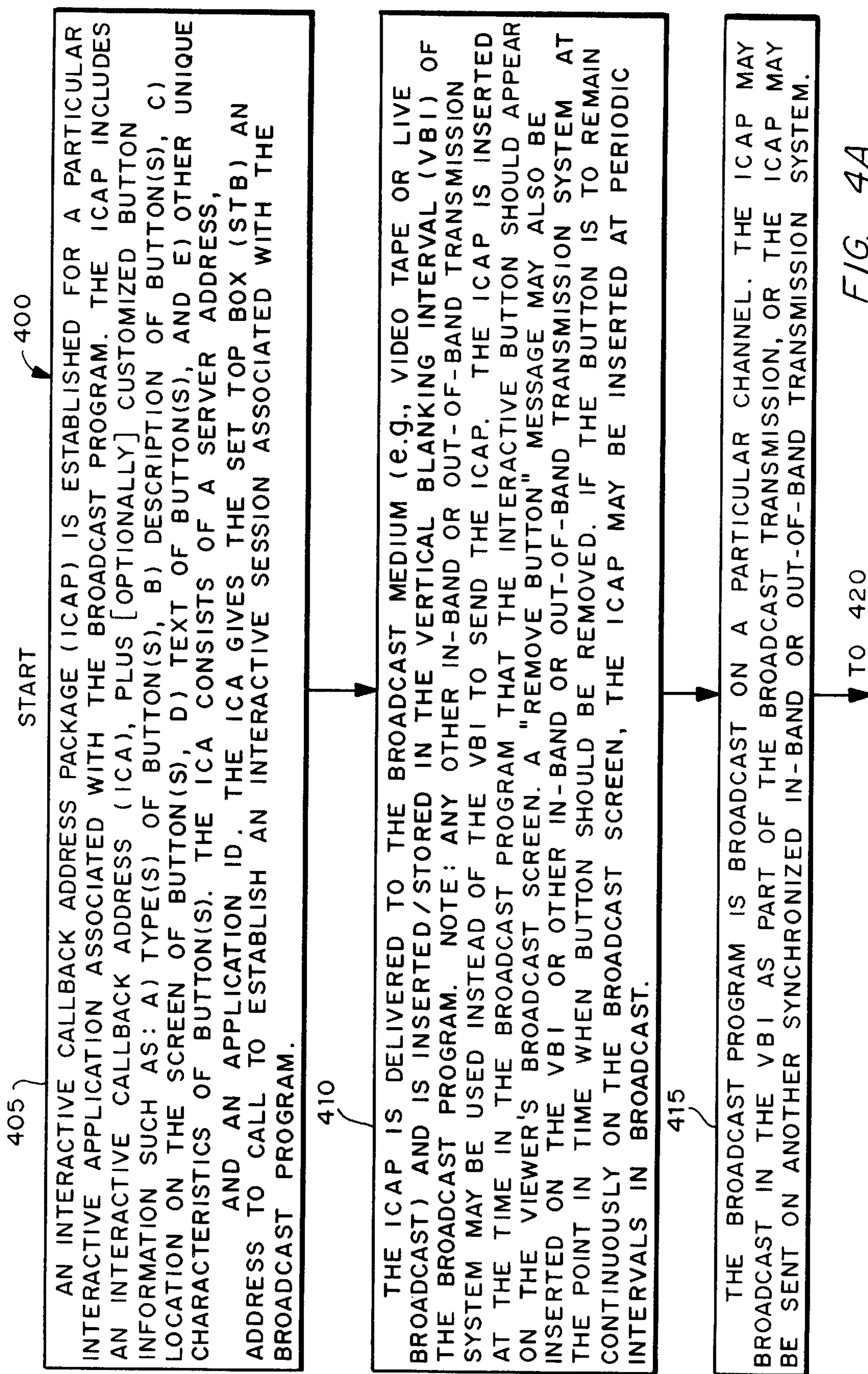
315

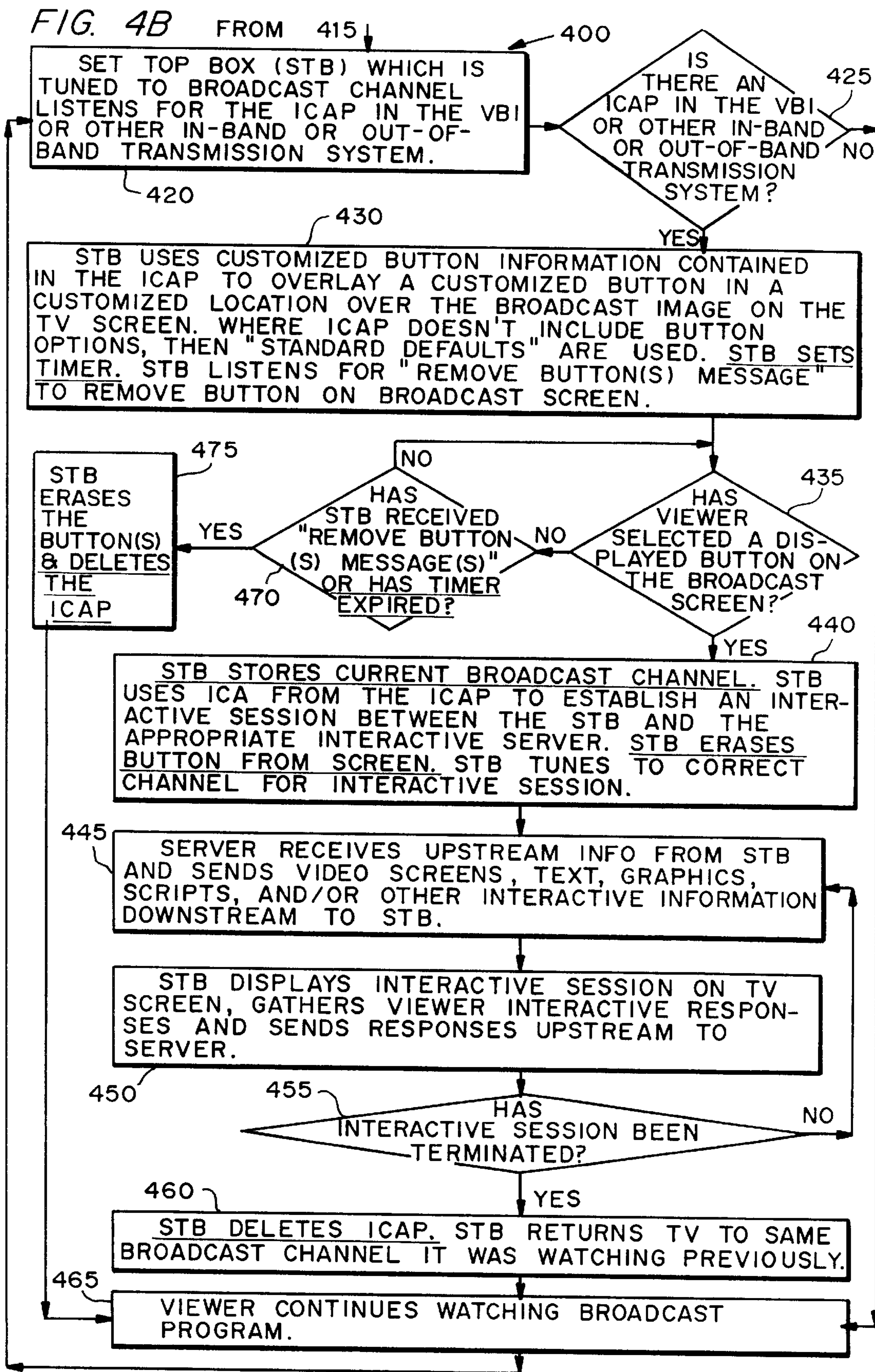
THE BROADCAST PROGRAM IS BROADCAST ON A PARTICULAR CHANNEL. THE WKICA MAY BE BROADCAST ON THE VBI AS PART OF THE BROADCAST TRANSMISSION, OR THE WKICA MAY BE SENT ON ANOTHER SYNCHRONIZED IN-BAND OR OUT-OF-BAND TRANSMISSION SYSTEM.

TO 320

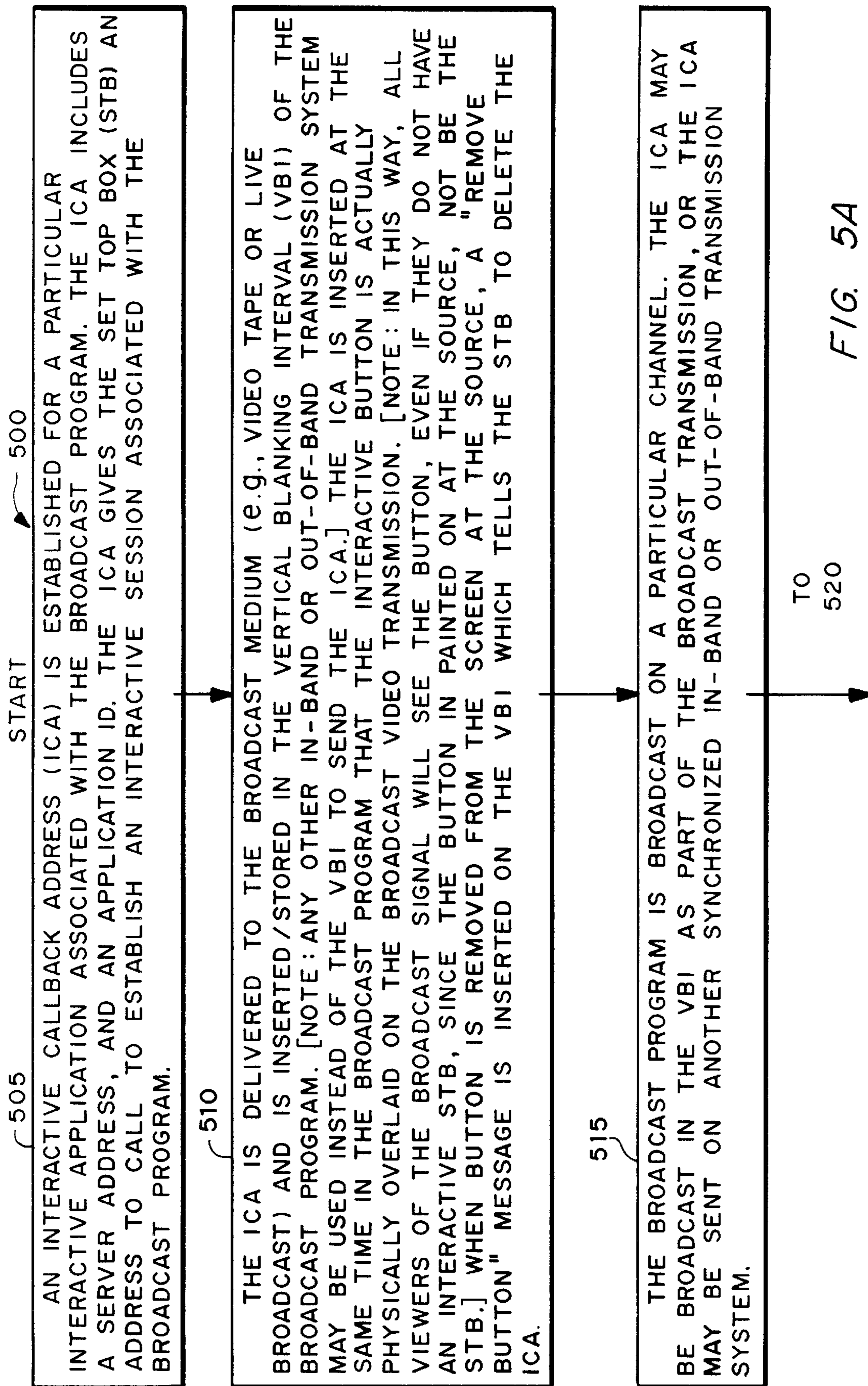
FIG. 3A

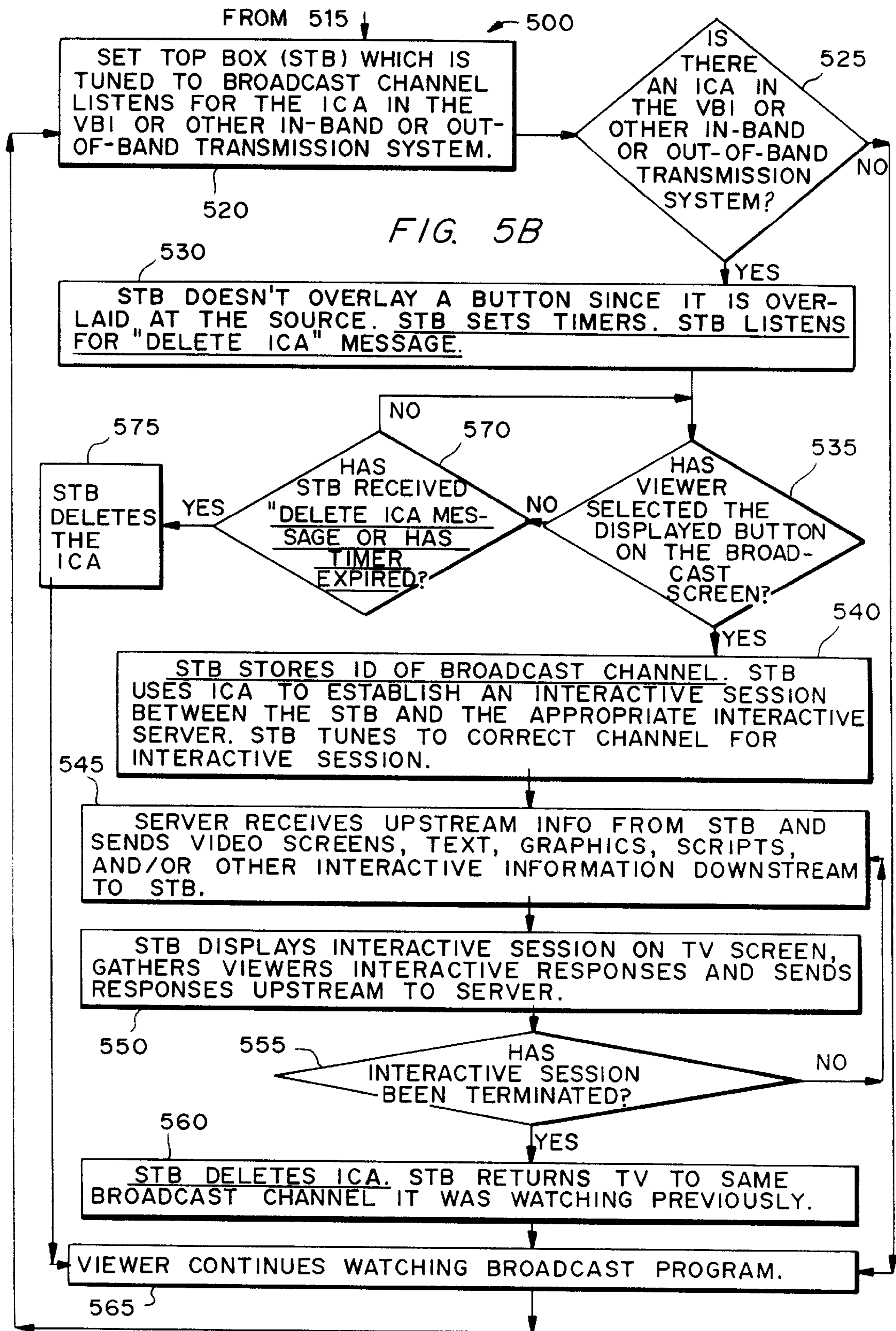












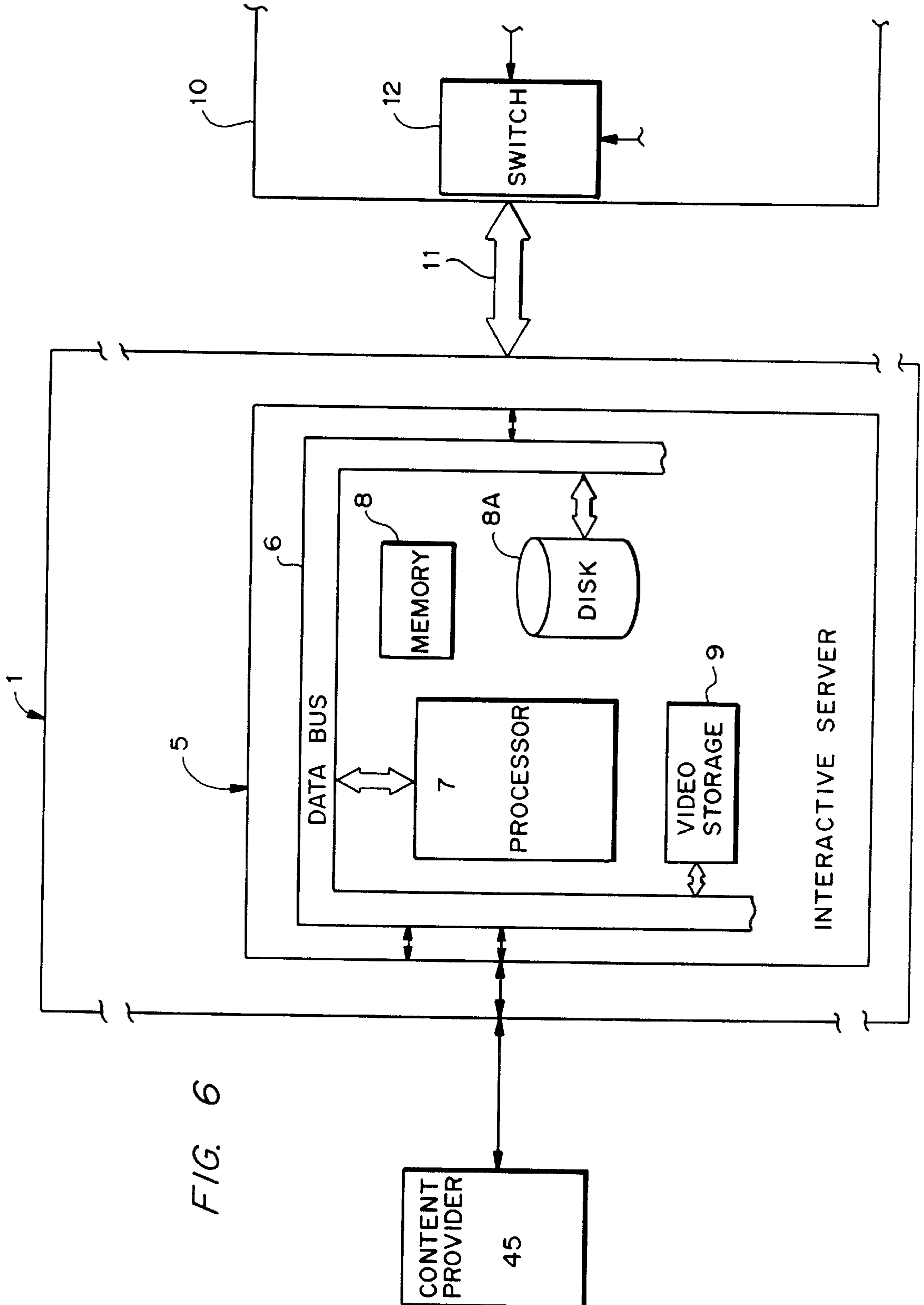


FIG. 6

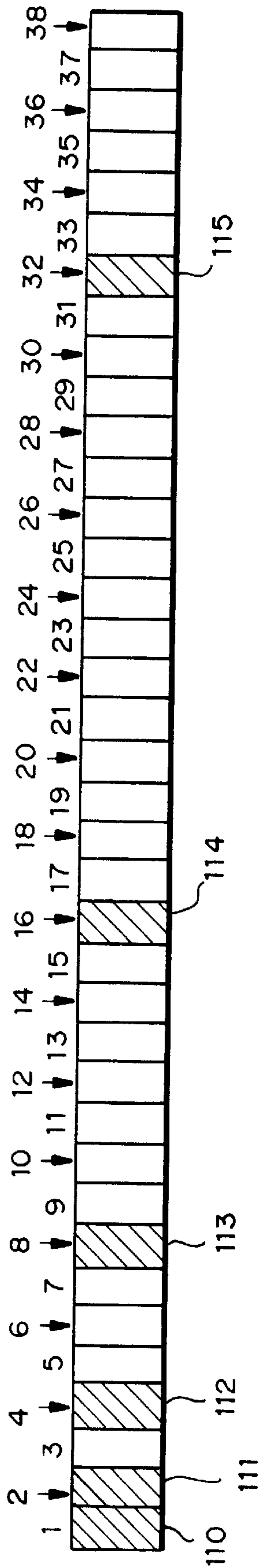


FIG. 7A

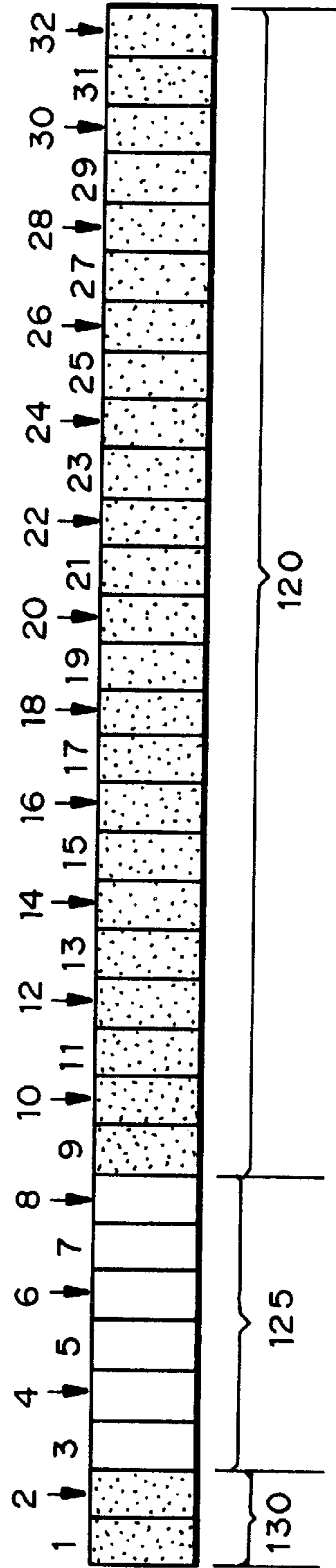


FIG. 7B

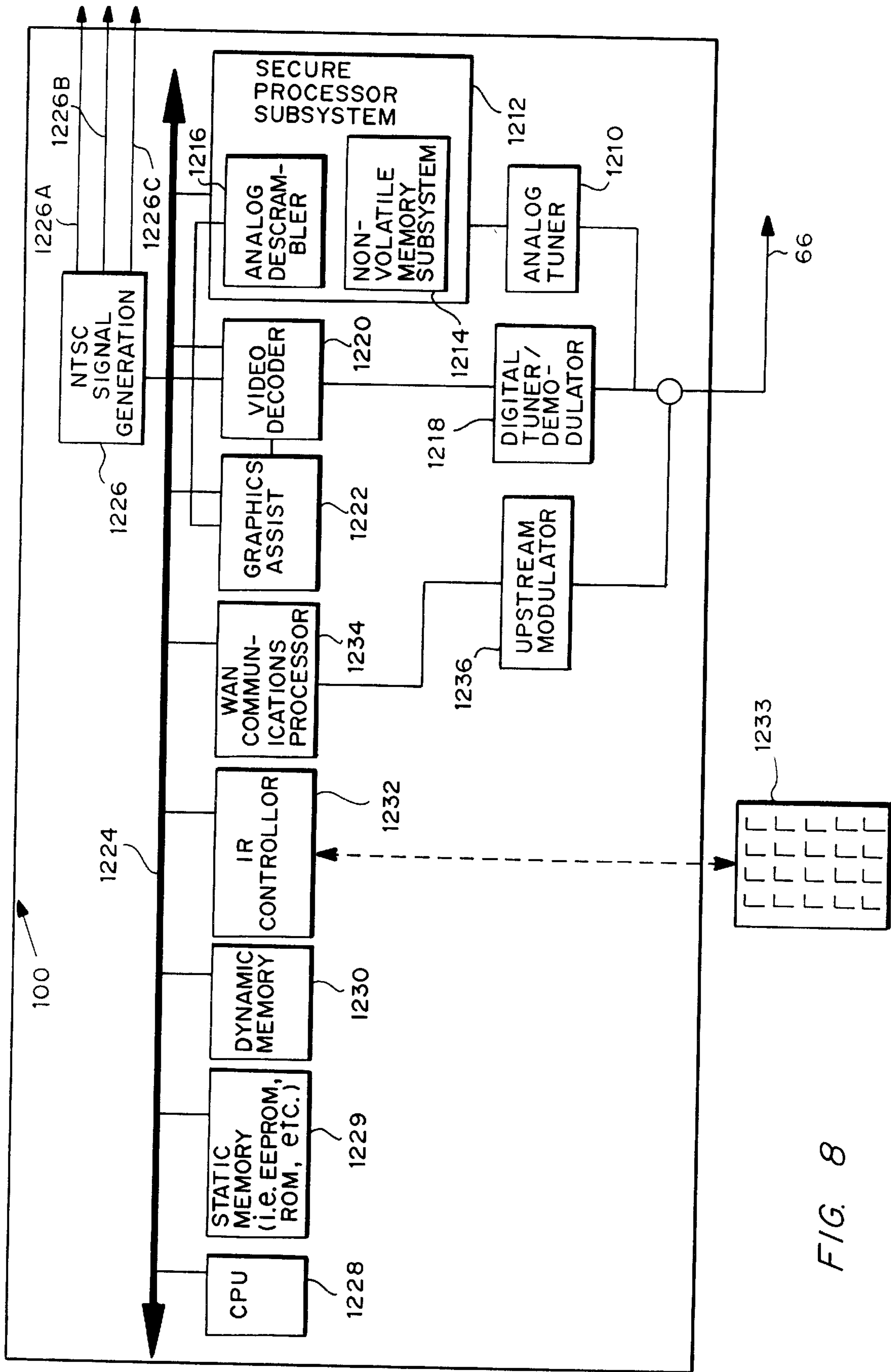
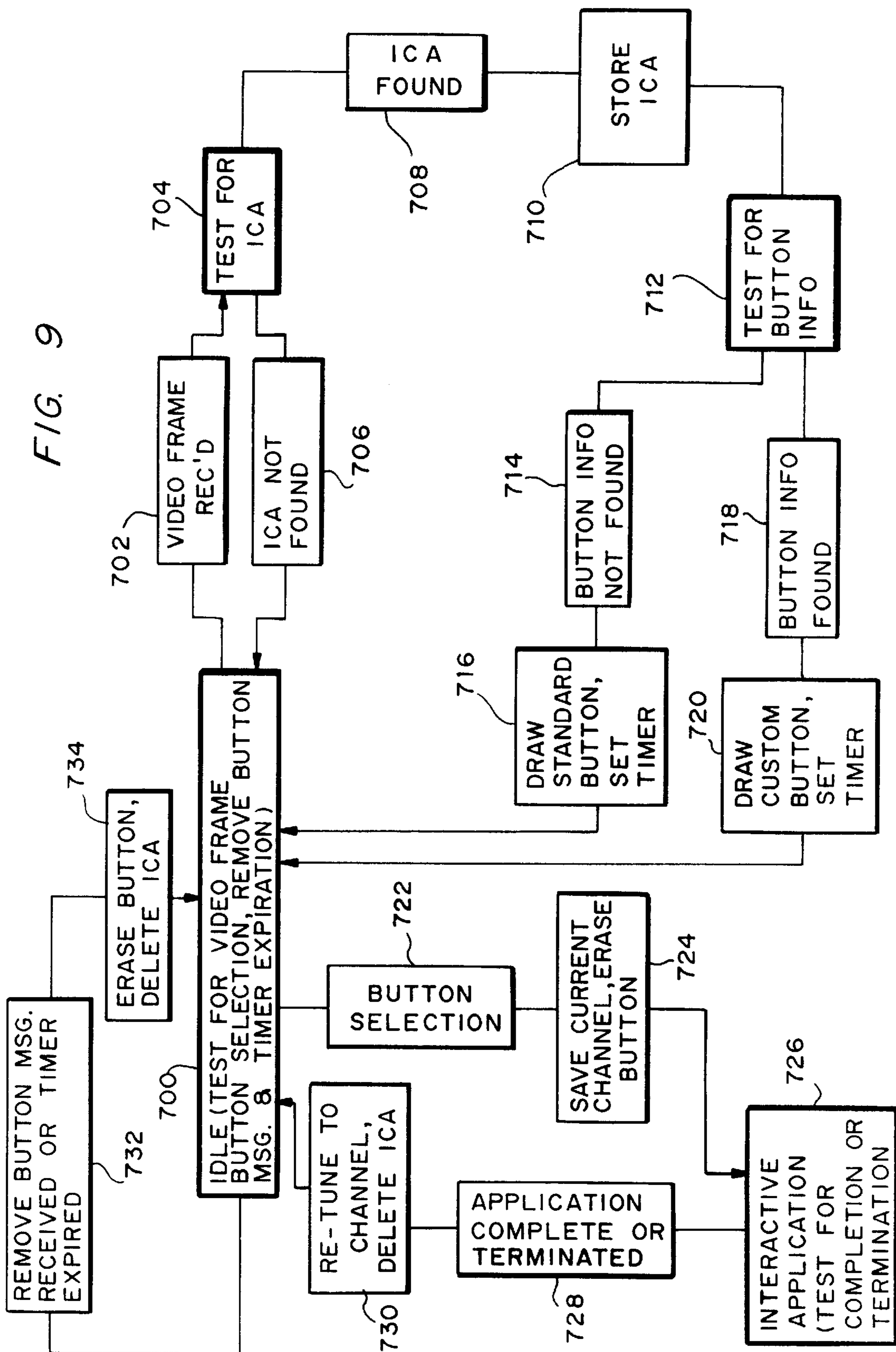
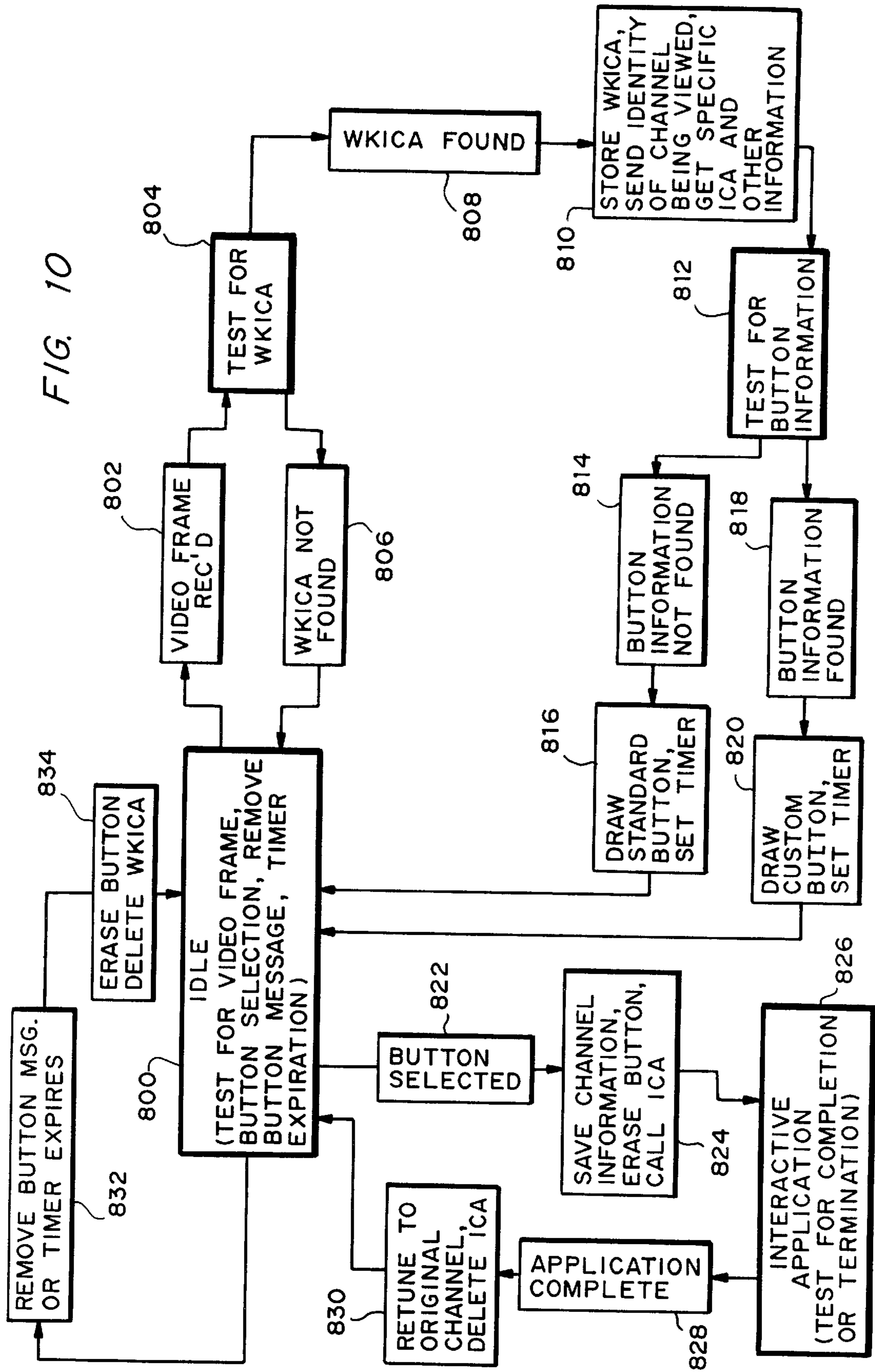
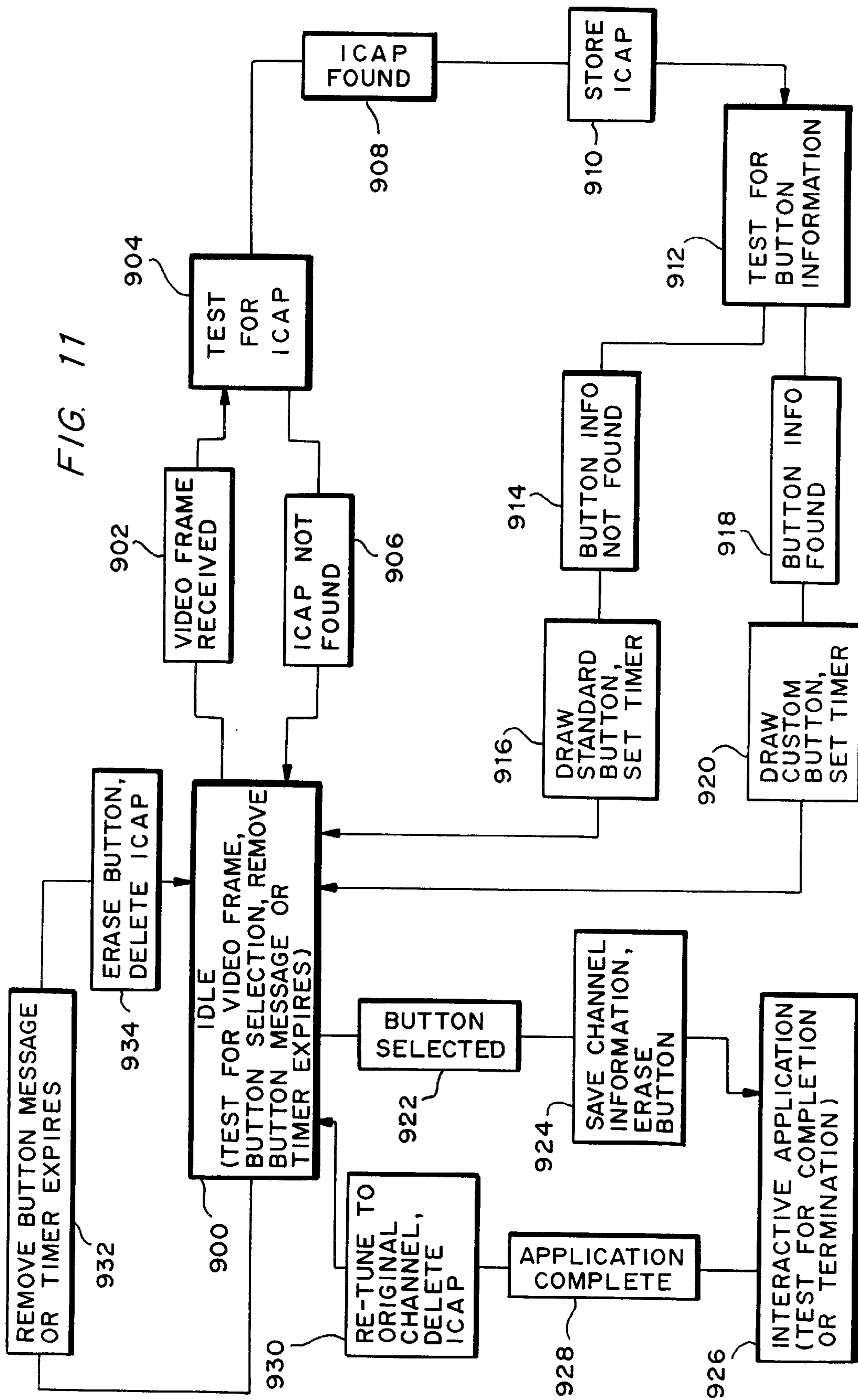


FIG. 8









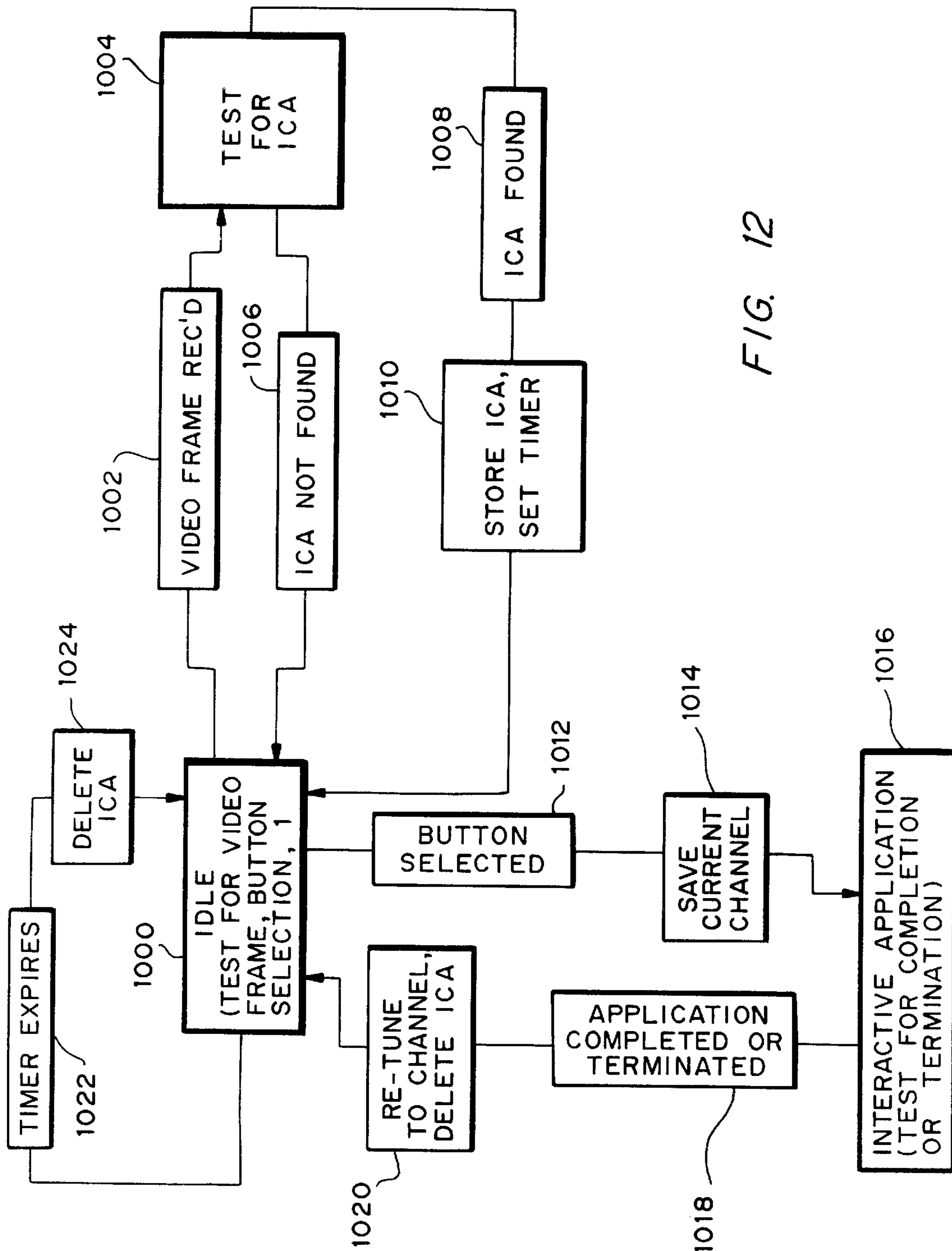


FIG. 12

## SYSTEM AND METHOD FOR PROVIDING TELEVISION SERVICES

### FIELD OF THE INVENTION

The present invention relates in general to the field of television and in particular to the field of interactive television.

### BACKGROUND OF THE INVENTION

Advances in telecommunications and computing technology are leading to the provision of interactive television (TV) on a large scale. Interactive TV involves the use of video gateways and video transport of sufficient bandwidth for video programmers and enhanced video gateway providers to offer their services to residential and business subscribers. Where such facilities are available, subscribers will not only be able to access these services by passively receiving them, but will also be able for the first time to interact with the service providers by communicating requests and commands to the providers via the same path over which the programming services are provided (or even via other paths or drivers).

Interactive TV service is capable of supporting at least the following services: (1) traditional broadcast and cable television programming; (2) video services, such as pay-per-view (PPV), near video-on-demand (NVOD), video-on-demand (VOD), promo channels, electronic program guides, etc.; (3) cable delivered PC-based services; and (4) interactive services, through the use of a combination of compression and digital video technologies. Interactive TV service also permits menuing capabilities and upstream signaling from subscribers to service providers. A subscriber interactive TV connection may, for example, provide subscribers with a screen of available enhanced video gateway providers and/or video programmers and their telephone numbers, or a menu to interactively order services and/or programs.

Interactive television may be provided over any number of paths, including coaxial cable or optical fiber, hybrid fiber/coaxial, or any other suitable path that accommodates sufficient bandwidth for desired analog and digital video channels as well as other telecommunications services. Content Providers may include, for example, providers of interactive or non-interactive over-the-air programming such as commercial television stations, cable programming such as weather, travel and entertainment channels, game channels, and on-line services of various types.

Interactive video enables a subscriber to request that an "interactive session" be established between an "interactive server" or similar platform maintained by an interactive video service provider and a "client" terminal device at the subscriber's premises. An interactive session is a two-way communication relationship, and is a precondition to interactive video services being provided to a subscriber's terminal device. Such a session utilizes the necessary downstream bandwidth and resources (defined below) for delivering interactive video service and the necessary upstream bandwidth from the subscriber's terminal device to issue commands to the interactive server. The terminal device may take the form of what has been termed a "set top box" (STB), or may be any other device capable of performing at least the following functions: (1) exchanging messages (including video-related data) over a network with the interactive server; (2) receiving messages from a user input device, such as a hand-held remote control unit; (3) translating video signals from a network-native format into a format that can be used by the television or display device;

and (4) providing a video signal to a television or other display device. A STB may also be capable of performing other functions, such as: (1) inserting alphanumeric or graphical information into the video stream in order to "overlay" that information on the video image; (2) providing graphic or audio feedback to a user; or (3) possibly the most basic function, simply routing a traditional broadcast signal to a viewing device to which the STB is connected.

The STB "client" is "served" by a facility which may be operated and maintained by the video service provider. This "interactive server" provides, in response to a subscriber request, access to an "application," which may be something as straightforward as a video program, or may itself interact with the subscriber by transmitting, for example, a subscriber prompt or menu to allow the subscriber to assert a desired selection from among a set of given commands for the interactive server to carry out.

This added functionality is in large part the result of a historically unprecedented convergence of communications and computing technology. It makes possible, for the first time, features such as the following. In the game media environment, a subscriber may download video games or even play them interactively with the interactive server and/or with other subscribers. An interactive service subscriber may order "time shift TV," in which a particular program may be viewed at a time following its ordinary broadcast time. A subscriber may also selectively view desired parts of transactional, informational or advertising services. For example, a subscriber may view information on the weather predictions for a given location or at a given time, gather information relating to a particular sporting event or team, obtain news on demand, or query a system regarding a particular real estate market. Alternatively, a subscriber may participate in interactive entertainment programs, such as interactive game shows, interactive lottery or gambling, or request musical selections. Subscribers interested in educational programming, such as a school or a family residence, may invoke interactive "edutainment" or "how-to" programs. Interactive communication services, such as on-line services historically provided by the public telephone network, may also be accessed via interactive TV, which permits not only the rapid transfer of files to the subscriber but also interaction with other subscribers.

The combination of broadcast and interactive applications over interactive TV (e.g., interactive programs) creates a new mode of communication in which a user, when informed of the availability of an interactive application relating to the subject matter of a broadcast program, may invoke the application to investigate that subject matter more thoroughly and according to his or her own tastes.

Additionally, television viewers, who are accustomed to choosing at will between the available channels with instantaneous results, will expect to pass from one medium (e.g., broadcast) to another (e.g., interactive) "seamlessly" with the push of a button. To accommodate their viewer's needs, programmers may wish to provide broadcast programming, such as a commercial advertisement or a news program, and make available in the context of that program a related interactive television program.

The means by which interactive television and broadcast television are provided, however, are generally quite different. The two media, for example, are typically supplied from different sources and use different modulation techniques over different transmission paths. The originating source of broadcast programming is likely to be remote from those subscribers interested in invoking an interactive service,

making telecommunication between the parties over a dedicated network prohibitively expensive and complex. By contrast, interactive servers, in order to avoid the expense of high bandwidth communications over such distances, can be located geographically close to a corresponding set of subscribers, unlike the programming sources or "Content Providers." An interactive server can therefore efficiently provide exclusive interactive access to a large number of applications by a large number of interactive subscribers.

The technical differences between broadcast programming and interactive applications, combined with the difficulties of providing interactive services at any rate, make the provision of a smooth transition between interactive and broadcast television a difficult proposition and a seamless transition from broadcast television to interactive television and back an elusive goal.

### SUMMARY OF THE INVENTION

The present invention provides an approach for viewer-friendly and virtually instantaneous transitioning from a first analog based television program to a second program, particularly an interactive application program, and further permits a similarly rapid and easily accomplished return to viewing the first program.

To accomplish this convenient and virtually instantaneous transition between programs such as a broadcast program and an interactive application or program, the present invention provides a system for permitting a provider of program content to furnish a video service provider with content, such as an interactive program or application, and for permitting the video service provider to transmit to the Content Provider an identifying code or address, such as an interactive callback address. The video service provider associates this identifying code or address with a location at which the program or application will be stored. The identifying code or callback address may be a program-specific code that can be used by subscribers to invoke the program from the video services provider directly. Alternatively, the identifying code may be a common identifying code or callback address (which might be called a "well-known callback address"), used by all subscribing viewers to access a program- or application-specific identifying code or callback address, which is in turn used to invoke the program.

According to the present invention, Content Providers may transmit the identifying code or callback address for a second program in coordination with a first program, so that viewers of the first program, who have access to systems operated by the video service provider, may invoke the second program, which may be an interactive program or application, using that identifying code or callback address.

Also according to the present invention, the Content Provider may transmit the identifying code or callback address in the first program signal, for example, in the vertical blanking interval of the video stream for that program. Alternatively, the identifying code or callback address could be provided in any other suitable out-of-band channel, especially one that is capable of being synchronized with the program signal, so that the identifying code or callback address may be transmitted at appropriate times during the program.

Additionally, the present invention permits the Content Provider to transmit with the identifying code or callback address additional information, such as information to be used at the subscriber site to generate a screen image indicating the availability of additional content from the video service provider.

The present invention also provides for an interactive server, which may be operated and maintained by the video service provider. The interactive server can service requests from Content Providers for identifying codes or callback addresses, such as interactive callback addresses, can store program content from Content Providers, such as interactive programs or applications, and can associate that content with an appropriate identifying code or address, such as an interactive callback address. The interactive server according to the present invention can also service requests for that content from subscribing viewers.

The subscribing viewers are provided with a set top box or similar device adapted to be coupled to a video distribution network to which one or more video service provider systems are also coupled, and also adapted to be coupled to a television, computer or any other suitable display device to reside either outside of, or within, the housing of the display device. The set top box includes a receiving set capable of receiving broadband signals over the video distribution network and possibly also over the air. The set top box also includes at least one processor coupled to the receiving set and programmed to detect the presence and content of an identifying code or callback address, such as an interactive callback address, received by the receiving set either in a program signal (typically in the vertical blanking interval of that signal) or possibly in an out-of-band signal. The set top box processor is also programmed to store the identity of the channel on which the program is being received in one of at least one information storage devices or memory means to which the processor is coupled. The processor is also programmed to detect and store information accompanying the transmission of the identifying code or callback address regarding an image to be displayed on the display device (such as a video screen "button" or "icon") to indicate the availability of content, such as an interactive application, from a video service provider. Alternatively, such information regarding the image to be displayed on the television or other display device may be pre-stored in an appropriate information storage device to which the processor is coupled. The processor is also coupled to a means for generating a video image based on the received or pre-stored "button" or "icon" information, or alternatively, is programmed to generate the video signal and is coupled to the display device in such a manner as to provide such a signal to that device.

Furthermore, the set top box processor is adapted to establish communication over the video distribution network with the video service provider, upon receiving a request from the subscribing viewer in response to seeing the screen button or icon. The processor may first store in the information storage device the identity of the channel on which the program then being viewed is being transmitted. A communication session over the network to the video service provider is then established by transmitting a message including the identifying code or callback address, such as the interactive callback address. If the identification code or callback address is a common identification code (for example, a "well-known callback address") the video service provider returns the program- or application-specific identification code or callback address, which the processor then may use to invoke from the video service provider the associated program or application.

The video service provider transmits to the set top box the identity of a network service (i.e., a network address) or a channel on which the requested program will be provided, and the set top box processor initiates a session with the indicated network service and/or causes the receiving set to

tune to the channel. The set top box then receives the program or application from the video service provider. During that session, communication between the set top box and the video service provider may be two-way.

When the program or application is terminated, or when the user signals the set top box that viewing the second program or application is no longer desired, the communication session is terminated. The processor then retrieves the identity of the first program from the information storage device, and causes the receiving set to re-tune to the first program to which the viewer had been tuned.

It is accordingly an object of the present invention to provide a system for permitting a Content Provider to furnish a video service provider with program content, such as an interactive application or program, and for permitting the video service provider to transmit to the Content Provider an identifying code or address, such as an interactive callback address or a "well-known interactive callback address."

It is an object of the present invention to provide a system for permitting a Content Provider to furnish an identifying code or callback address along with a program for directly invoking another program, such as an interactive program furnished to subscribing viewers by the video service provider.

It is a further object of the present invention to provide a system for permitting a Content Provider to furnish a common identifying code or callback address (such as a "well-known interactive callback address"), used by all subscribing viewers to access a program- or application-specific identifying code or callback address that, in turn, is used to invoke the program content from the video service provider.

It is an additional object of the present invention to permit a Content Provider to transmit the identifying code or callback address in coordination with the program signal, such as in the vertical blanking interval of the video stream.

It is a further object of the present invention to permit a Content Provider to optionally transmit the identifying code or callback address in coordination with the program signal, but in any suitable out-of-band channel.

It is yet another object of the present invention to permit the Content Provider to transmit with the identifying code or callback address additional information, such as information to be used at the subscriber site to generate a screen image indicating the availability of additional content from the video service provider.

A further object of the present invention is to provide an interactive server capable of servicing requests from Content Providers for identifying codes or addresses for program content and to receive and store such content in association with the identifying code.

An additional object of the present invention is to provide an interactive server according to the present invention that can service requests for program content from subscribing viewers.

Another object of the present invention is to provide subscribing viewers with a set top box for detecting the presence and content of an identifying code or callback address transmitted in coordination with a program, to store for later retrieval the identity of the channel on which the program is being received, to generate a screen image for display on a display device based on information either pre-stored or transmitted with the identifying code, to establish a session with the video services provider using the

code, and upon termination of the session, to fetch the identity of, and re-tune to, the channel the subscriber was originally watching.

#### BRIEF DESCRIPTION OF THE DRAWINGS

FIG. 1 is a high level functional block diagram of certain environment and components of a system according to a preferred embodiment of the present invention.

FIGS. 2A and 2B are a flowchart for the operation of a first embodiment of a system according to the present invention.

FIGS. 3A and 3B are a flowchart for the operation of a second embodiment of a system according to the present invention.

FIGS. 4A and 4B are a flowchart for the operation of a third embodiment of a system according to the present invention.

FIGS. 5A and 5B are a flowchart for the operation of a fourth embodiment of a system according to the present invention.

FIG. 6 is a high level diagram of an embodiment of an interactive server and certain environment according to the present invention.

FIG. 7A is a diagram showing the format for an interactive callback address according to the present invention having error correction check bits.

FIG. 7B is a diagram showing the contents of an interactive callback address according to the present invention, with the error correction check bits not shown.

FIG. 8 is a high level schematic diagram of a preferred embodiment of a set top box according to the present invention including input and output means.

FIG. 9 is a state diagram showing operating states of an embodiment of a set top box according to the present invention, corresponding to the embodiment of the system according to the present invention shown in FIGS. 2A and 2B, and indicating conditions leading to state transitions and processing associated with the states and performed incident to the state transitions.

FIG. 10 is a state diagram showing operating states of an embodiment of a set top box according to the present invention, corresponding to the embodiment of the system according to the present invention shown in FIGS. 3A and 3B, and indicating conditions leading to state transitions and processing associated with the states and performed incident to the transitions.

FIG. 11 is a state diagram showing operating states of an embodiment of a set top box according to the present invention, corresponding to the embodiment of the system according to the present invention shown in FIGS. 4A and 4B, and indicating conditions leading to state transitions and processing associated with the states and performed incident to the transitions.

FIG. 12 is a state diagram showing operating states of an embodiment of a set top box according to the present invention, corresponding to the embodiment of the system according to the present invention shown in FIGS. 4A and 4B, and indicating conditions leading to state transitions and processing associated with the states and performed incident to the transitions.

#### DETAILED DESCRIPTION

##### High-Level Architecture of an Embodiment of an Interactive Video Services Network

FIG. 1 shows the primary components used in a typical setting for implementing an embodiment of the systems,

devices and methods according to the present invention. A video service provider **1**, responsible for providing interactive applications, operates and maintains a system equipped to receive signals as well as interactive applications and other content from one or more Content Providers A, B, C, . . . , N, respectively referred to by numerals **41–44**. The means by which interactive applications are furnished by the Content Providers to the video service provider **1** is discussed in detail below and in the section entitled “Assignment of Interactive Callback Address.”

Content Providers may be any original or secondary source of programming or information generally, including, for example, interactive or non-interactive over-the-air programming such as commercial television stations, cable programming such as weather, travel and entertainment channels, game channels, and on-line services of various types. Content Providers may alternatively broadcast directly to viewers, without the necessity of the broadcast being received and retransmitted to subscribers.

Over-the-air broadcast Content Providers such as commercial television stations, which may not provide programming by way of the video service provider **1** may nevertheless furnish the video service provider **1** with interactive applications associated with their broadcasts. An example of such a Content Provider is Content Provider A **41**. According to an approach described below, a video service provider **1** that has received an interactive application from Content Provider A **41** may then provide access to the interactive application to subscribers **70** of the video service provider **1**, in response to subscriber requests.

Content Providers that may not transmit programming to viewers over the air but which may provide it via cable, for example, such as weather, entertainment and game program providers, which may be represented by Content Provider B **42**, may provide programming to viewers via the video service provider **1**. This programming could be sent to the video service provider **1** in the form of an RF transmission, in which case the signal would be received and suitably processed by RF equipment **25**. Alternatively, the programming might be transmitted to the video service provider **1** over, for example, a network according to a cell- or packet-switching or other suitable protocol. In the latter event, the programming signal could be received at network provider **10** via the video service provider **1** and switch **12**. Switch **12** would in turn provide the received signal, along with numerous other signals it would in general handle, to signal processor **14**, which conditions the signal for receipt and transmission by RF equipment **25**.

Content Providers A–N may also furnish the video service provider **1** with one or more interactive applications which the video service provider **1** may in turn provide to subscribers **70** of the video service provider **1** in response to subscriber requests.

Other providers of television content such as advertisers, which may be represented by Content Provider C **43**, may not provide services to viewers but rather furnish content originating with them to broadcasters that incorporate that content into their own broadcasts. They may also furnish interactive applications to the video service provider **1**, as further described below. The video service provider **1** may then provide access by subscribers **70** to the interactive application.

Signals containing programming furnished by the Content Providers A–N (ref. numerals **41–44**) may have inserted into them interactive callback addresses by one or more ICA insertion mechanisms. For example, ICA insertion mecha-

nism **20** can be connected via suitable communication paths to Content Provider B **42** and to interactive server **5**. Insertion mechanism **20** can be any known equipment for inserting information in a television signal, for example, in line **21** of the vertical blanking interval of an NTSC video signal. Content Provider B **42** may decide to transmit a broadcast, such as a commercial, having an associated interactive component or application that may have been provided to the video service provider **1** and is stored in the interactive server **5**. Content Provider B **42** then queries interactive server **5** for the network address and application ID for the associated interactive component. In response to the query, the interactive server **5** identifies the network address and application ID for the associated interactive component which, together, constitute an interactive callback address or ICA. Content Provider B **42**, which is able to issue instructions to ICA insertion mechanism **20**, inserts the ICA received from the interactive server **5** into the transmission (e.g., of the commercial) when it is broadcast. As will be further described below, a properly equipped subscriber STB **100** will be able to sense the ICA on that broadcast channel and then display a button or icon on the viewing screen over the broadcast channel and also store the ICA. If the subscriber selects the displayed button, the STB **100** establishes a session with interactive server **5** and receives the interactive program or application associated with the broadcast.

An ICA may be inserted in a broadcast signal by other means. For example, ICA insertion mechanism **22** can be operated and controlled by the video service provider **1**. ICA insertion mechanism **22** can be any known mechanism for inserting information into a television signal (as with ICA insertion mechanism **20**). A communication path is established between insertion mechanism **22** and interactive server **5**. ICA insertion mechanism **22** is also in communication with Content Provider B **42** and with RF equipment **25** in network provider **10**. Content Provider B **42** may decide to air a broadcast, such as a commercial, having an associated interactive component or application available on interactive server **5**. As shown in FIG. **1**, Content Provider B **42** may broadcast directly to RF equipment **25** or through switch **12**. In the event that the broadcast will be directly to the RF equipment **25**, Content Provider B **42** prior to or during airing of the broadcast transmits a notice to video service provider **1** that the broadcast program is to be transmitted at a given time. In response to this notice, the interactive server **5** identifies the network address and application ID for the interactive component associated with the broadcast, which, together, constitute an interactive callback address or ICA. Interactive server **5**, which maintains control over the ICA insertion mechanism **22** inserts the ICA received from the interactive server **5** into the transmission (e.g., the commercial) when it is broadcast and communicates the resultant signal to RF equipment **25** of network provider **10**.

In the event that a Content Provider such as Content Provider B **42** is transmitting a broadcast via switch **12** in network provider **10**, ICA insertion mechanism **24** is in communication with interactive server **5**, Content Provider B **42**, and switch **12** of network provider **10**. As with the ICA insertion mechanism **24**, Content Provider B **42** prior to or during airing of the broadcast transmits a notice to video service provider **1** that the broadcast program is to be transmitted at a given time. In response to this notice, the interactive server **5** identifies the network address and application ID for the interactive component associated with the broadcast, which, together, constitute an interactive callback

address or ICA. Interactive server **5**, which maintains control over the ICA insertion mechanism **24**, as well as ICA insertion mechanism **22**, inserts the ICA received from the interactive server **5** into the transmission (e.g., the commercial) when it is broadcast, and communicates the resultant signal to switch **12** of network provider **10**.

In one embodiment of the invention, a video service provider **1** provides its services using at least some of the components shown in FIG. **1**. The services provided by video service provider **1** may include voice, data, and video services, including interactive TV and cable channel service, and including both service that is multi-cast (to all subscribers) and switched (to particular individual subscribers), which may be interactive in nature. The primary functionality of the service provider **1** in this embodiment is provided by interactive server **5**, which stores and manages the interactive applications provided by the Content Providers, and which responds to requests from subscribers **70** during interactive sessions subscribers **70** initiate. Interactive server **5** is shown and described in greater detail in FIG. **6** and the accompanying text.

Although the present discussion focuses on the provision of interactive applications, the video service provider **1** may be an enhanced video gateway provider, offering service including menuing and navigation capabilities, billing and collections, information services, storage and order processing. As in the embodiment shown in FIG. **1**, the “Level 2” or “L2” Service, presently defined, along with the subscriber **70** set top box (“STB”) **100**, by the Federal Communications Commission (“FCC”) as the unregulated portion of a video services network, is implemented by the video service provider **1**. In this embodiment, the video service provider **1** is physically separated from the “Level 1” or L1 service, defined by the FCC as the regulated portion of a video services network and the portion of the system known as “video dial tone,” functionality of which is implemented by network service provider **10** in FIG. **1**. In this configuration, the L1 service might serve a number of such video service providers (although only one is shown and described for convenience). Alternatively, the video service provider **1** may at the same site provide both L1 and L2 services.

Interactive server **5**, which is part of the L2 Service, is linked to a switch **12**, part of the L1 service, for transferring data according to any desired protocol or scheme, such as the ATM cell-switching protocol, for example. The switch **12** may also switch video signals from Content Providers, as shown FIG. **1** for Content Providers B–N (reference numerals **42–44**, respectively), to one or more video signal processors **20** for delivery to the network distribution facilities. In an embodiment of the invention, signal processing equipment **14**, network controller **16**, RF equipment **25** and electrical/optical converter **30** all serve to interface the switch **12** with the broadband distribution system **50**.

The signal processing equipment **14** receives digital video signals and transforms them into properly timed and mapped broadband signals for transmission to subscribers. One example of the standard according to which such transformation may be performed is the MPEG-2 standard (Moving Pictures Expert Group standard **2**, an international video and audio compression and transmission standard described in ISO/IEC CD 13818-1, the contents of which are incorporated by reference herein); however, any other suitable standards, formats, protocols, data structures, sequences or organization schemes could also be employed just as easily and effectively.

Network controller **16** receives input via signal processor **14** from the STB **100** of subscriber **70** and sends output to

the switch **12**, signal processor **14**, and to the interactive server **5** in order to establish network sessions that permit downstream transmission of broadcast and interactive applications from the interactive server **5**, as well as upstream signalling from STB **100** of subscriber **70**. The network controller **16** output to switch **12** and signal processor **14** also provisions network resources to achieve these functions.

The RF equipment **25** provides RF modulation and RF combining for transmission of video signals onto the broadband distribution system **50**. It receives input from the switch **12** in, for example, ATM format and may receive input directly from Content Providers, such as the Content Provider B **42**. It provides output in the form of RF transmission either directly (not shown) onto a broadband RF distribution network **50**, or if the broadband RF distribution network is implemented with optical fiber, it provides output to electrical/optical converter **30**. In this event, converter **30** transforms the input received from the RF equipment **25** and places it onto the broadband distribution system **50**.

The switch **12**, network controller **16**, RF equipment **25**, electrical/optical converting equipment **30** and broadband distribution system **50** together make up at least part of the L1 service provided by network service provider **10**. Network service provider **10** is responsible for setting up and maintaining a communications interface between the interactive server **5** and the STBs **100** of a node **60** of subscribers. Network service provider **10** receives an application transmission from the interactive server **5** in the downstream direction. Network service provider **10** receives application transmission in the upstream direction from subscriber STBs **100** (to be discussed at greater length below) via broadband RF transmission.

As shown in FIG. **1**, provision of programming by the Content Providers **41–44** may be: directly to viewers, including one or more subscribers **70**, who may receive the signal, for example, with a conventional antenna (see Content Provider A **41**); via the service provider without requiring digital switching or conversion to broadband, when the signal is already in broadband format which may be the case, for example, if the Content Provider is a provider of over-the-air or cable channel service (see Content Provider B **42**); or via the service provider **1** through the switch **12** and signal processor **14**. Not shown in FIG. **1**, but described below with reference to FIGS. **6** and **7**, is the provision of interactive applications from the Content Providers **41–44** to the video service provider **1**, and the provision of an identifying code such as an interactive callback address from the video service provider **1** to the Content Providers **41–44**.

A video signal provided by, or by way of, the video service provider **1** is placed on the broadband distribution system **50**. Broadband distribution system **50** is most preferably a broadband network with bandwidth on the order of 750 Mhz, but it may feature a suitable bandwidth for the program content and functionality desired. In the presently described embodiment of the video dial tone system, the distribution is partitioned into a 50–750 Mhz downstream path for the provision of video services and a 5–42 Mhz upstream path for signalling by a subscriber **70** to the video service provider **1**.

Broadband distribution system **50** provides a link between the video service provider **1** and one or more nodes **60** of subscribers **70**. One such subscriber node **60** is shown in FIG. **1**. In an embodiment of the video dial tone system, a subscriber node **60** may include a remote terminal **65**, which converts optical signals received over the network to elec-

trical signals. The electrical signals are then provided on a coaxial distribution system **66** to a number of taps (not shown), each of which may serve a number of subscribers **70**.

Subscriber **70** is situated similarly to a typical television viewer in a number of respects. As shown in FIG. **1**, the subscriber is equipped with one or more televisions **80**, **90** or other suitable image monitoring devices. As depicted in the Figure, a television **90** may be connected directly to the coaxial distribution system **66**, rather than via the STB **100**, as in the case of television **80**. The subscriber is further equipped with a set top box **100** that is also coupled to the coaxial distribution system **66**. The STB **100** may be a device with certain similarities to conventional cable company STBs. However, the particular requirements of the STB **100** for implementing the present invention, including functionality not present in conventional STBs, are shown in greater detail in FIG. **8**, which shows the components of an embodiment of an STB **100**, and FIGS. **9** to **12**, which depict the logic flow for four embodiments of an STB **100** according to the present invention and corresponding respectively to FIGS. **2A–B** to **5A–B**.

#### Operation of Several Embodiments of a System According to the Present Invention

An interactive application must be associated with an identifying code such as an interactive callback address if it is to be invoked by subscribers. The provision of this code or address to subscribers in the context of other programming is what allows a subscriber **70** with the proper equipment and data links to invoke the interactive application. The provision of an address in response to a request by a Content Provider can be accomplished in several ways, to be discussed at further length below. In addition, the address can be provided to the subscriber **70** in various ways, and the manner in which this address (and information regarding the availability of an interactive application) is provided determines to a certain extent the overall functioning of the system. Four illustrative approaches to providing an address, which may be referred to as an “interactive callback address” or “ICA,” will be discussed, along with the operation of systems according to the present invention for implementing these approaches, in relation to FIGS. **2A**, **2B**, **3A**, **3B**, **4A**, **4B**, **5A** and **5B**. These Figures present each of the four approaches as a logic flow. The approaches are to be taken without limitation as examples of ways in which devices, systems, and methods according to the present invention may be carried out. The division of these logic flows into the boxes shown in the Figures is also by way of example, rather than of limitation (as is the remainder of this document).

#### Application-Specific Interactive Callback Address Transmitted With Broadcast and Identified by Standard Button Overlay

In FIG. **2A**, at **205**, an ICA is established (as further described below) for a particular interactive application associated with given programming. The ICA describes a logical address that would map to an interactive server’s network address, includes an application ID, and may include a “timeout” period, which is the time that the button should be displayed on the broadcast screen. The STB **100** may also have a standard default timeout period, if no timeout is sent with the ICA. A subscriber’s STB **100**, when equipped with this ICA, can call the interactive server **5** to establish a session with the interactive application associated with the program.

At **210**, the ICA is delivered to a medium (such as, for instance, a provider of program material such as video tape or live broadcast) and, in a preferred embodiment of the invention, is inserted or stored in the vertical blanking interval (VBI) of the desired program associated with the medium. As an alternative to providing the ICA in the VBI of a broadcast program, any other synchronized in-band or out-of-band transmission system may be used. As further described below, the ICA serves as a complete or partial basis for the STB **100** of a subscriber **70** to generate a signal representing a “button” for inclusion on the screen of the television **80** of subscriber **70**. The ICA is inserted in the program such that the interactive button may be generated by a subscriber’s STB **100** to appear at the desired time on the screen of a subscriber **70** tuned to that program. A “remove button” message may also be inserted in the VBI (or, again, another synchronized in-band or out-of-band transmission system) at the point in time when the button should be removed by the STB **100**. Alternatively, the button may be removed if a new ICA is received, or if a timer expires, or finally, if the broadcast channel is changed. If, on the other hand, the button is to remain continuously on the screen, the ICA may be inserted at periodic intervals in the program.

At **215**, the program is delivered on a given channel. If the ICA was inserted into the VBI, it will of course be included as part of the transmission. Alternatively, the ICA may be sent over another in-band or out-of-band transmission system synchronized with the program.

Referring to FIG. **2B**, at **220**, the STB **100**, which is tuned to a given channel, listens for the ICA in the VBI or other appropriate transmission. If an ICA is detected, at **225**, the STB **100**, at **230**, overlays a screen button having a standard predetermined configuration on the image displayed on the screen of TV **80** to which the STB **100** is connected. The provision and storage of the information required to generate the standard button is discussed at greater length below in the context of the STB **100**. Also at **230**, STB **100** sets an internal timer to a timer value sent as part of the ICA, or if no timer value is sent, to a standard timeout value. If no ICA is detected, the subscriber **70** continues watching the program, at **285**, and the STB **100** continues to listen for an ICA, at **220**.

As indicated at **235**, if the subscriber **70** has selected the displayed button, at the next step, **240**, STB **100** stores the identity of the current broadcast channel. STB **100** then resolves the ICA from a logical address to a network address and then uses the ICA to establish an interactive session between itself and the interactive server **5** corresponding to the ICA. At this point the STB **100** stores the identity of the current channel for later retrieval, erases the button from the screen, and then tunes to the correct channel for maintaining the interactive session, which channel was received from the interactive server **5** according to standard protocols when STB **100** requested an interactive session.

As indicated at **245**, the interactive server **5** receives upstream data from the STB **100** and, in response, sends appropriate video screens, text, graphics, scripts, and/or other information downstream to the STB **100**. The STB **100**, at **250**, displays on the TV **80** the interactive session received from the interactive server **5**, and sends subscriber **70** responses upstream to the interactive server **5**.

As indicated at **255**, the STB **100** checks whether the interactive session has been terminated. This event will occur at the end of the interactive application, in which case the interactive server **5** terminates the session. Termination

may also, of course, occur if the subscriber **70** requests it. If the session has been terminated, the STB **100** deletes the ICA, retrieves the identity of the channel that was previously being watched, and re-tunes the TV **80** to that channel. If the session has not been terminated, the interactive server **5** continues to receive upstream information from the STB **100** and to send video screens, text, graphics, scripts, and/or other interactive information downstream to the STB **100**, as shown at **245**.

At **265**, after the STB **100** has returned the TV **80** to the original program channel, at **260**, the STB **100** queries whether the button is still on the screen. If it is, the next query, at **270**, is whether the STB **100** has received a "remove button" message. If the STB **100** has received the "remove button" message, then, at **275**, it erases the button. Alternatively, if the STB **100** has not received the "remove button" message, but the timer has reached the timer value transmitted with the ICA indicating that the timeout period has elapsed (described in further detail below in connection with the STB **100** logic), the STB **100** erases the button.

If, at **235**, it had been determined by the STB **100** that the subscriber **70** did not select the displayed button, the STB **100** checks whether it has received a "remove button" message or if the timeout period has expired, at **270**. If either of these conditions has occurred, the STB **100** erases the button at **275** and deletes the ICA. Following **275** or **280**, the viewer continues watching the program, at **265**, and, returning to **220**, the STB **100** resumes listening for an ICA.

#### Well-Known Interactive Callback Address Transmitted With Program and Identified by Standard Button Overlay

An alternative to the application-specific callback addressing scheme described above in connection with FIGS. **2A** and **2B** is presented in FIGS. **3A** and **3B**. These figures show the logical flow of an approach in which a single common identifying code or "well-known" interactive callback address is provided to all subscribers **70**, indeed all viewers, but which only the subscribers **70** use if they elect to invoke that application from the interactive server **5**.

At **305**, a program- or application-specific identifying code or ICA is established (as further described below) for a particular interactive application associated with a given program. As with the first approach, the ICA describes a logical address that would map to an interactive server's network address, includes an application ID, and may include a "timeout" period, which is the time that the button should be displayed on the broadcast screen. Also, a well-known interactive callback address ("WKICA") is established for all interactive applications associated with all programs. The WKICA generally includes the same sort of information as does the ICA.

The WKICA is a common address used by all STBs **100**. The STBs **100** call the WKICA to get the ICA information associated with the particular interactive application, (which would include the server ID if the subscriber were to have access to more than one interactive server). Once the STB **100**, using the WKICA, has obtained the desired ICA, it will call for the desired interactive application using that ICA.

At **310**, the WKICA is delivered to a medium (for instance, a provider of program material such as video tape or live broadcast) and, in a preferred embodiment of the invention, is inserted or stored in the VBI of the desired program associated with the program medium. As an alternative to providing the WKICA in the VBI of a program, any

other in-band or out-of-band transmission system may be used if it is synchronized with the program. The WKICA is inserted so that it will appear on the TV **80** screen of subscriber **70** during the desired time in the program. A "remove button" and/or time expiration message may also be inserted in the VBI (or other synchronized transmission system) at the point in time when the button should be removed. If the button is to remain continuously on the screen, the WKICA may be inserted at periodic intervals throughout the program.

The program is then transmitted at **315**, on a particular channel. The WKICA is thus included in the VBI as part of the program transmission, or it may be sent on another in-band or out-of-band transmission system synchronized with the program.

Referring to FIG. **3B**, the STB **100**, tuned to a particular program channel, listens, at **320**, for the WKICA in the VBI or other appropriate transmission system. If, at **325**, a WKICA in the VBI or other system is detected, an interactive session is established at **330**; otherwise, the viewer continues watching the program and a timer is set, at **385**.

At **330**, the STB **100** calls the WKICA to establish an interactive session with the application identified by the WKICA. At the outset of the session, the STB **100** provides the application identified by the WKICA with the identity of the channel being viewed by the subscriber **70**. The STB **100** receives from the application specific information associated with the program channel, such as the type of button to display and the specific ICA to call to establish the appropriate interactive session, assuming the subscriber **70** selects it by pressing the button. The STB **100** sets the timer and displays on the screen of the TV **80** the type of button specified by the application associated with the WKICA and proceeds to wait for a "remove button" message or for the period for which the timer is set to expire. The STB **100**, using components and according to processing further described below, generates the button based in part on information previously stored, for example by software download, in the STB **100**.

The STB **100** also waits, at **335**, for the subscriber to select the button on the viewing screen. If a selected button is detected, the STB **100** at **340** stores the identity of the current broadcast channel in memory for later retrieval. It then calls the specific ICA it has received from the WKICA to establish the appropriate interactive session for the button that was pressed. The STB **100** also erases the button from the screen, and tunes to the appropriate channel for the interactive session.

During the interactive session, such as at **345**, the interactive server **5** receives upstream information from the STB **100** and sends downstream to the STB **100** text, graphics, scripts, and/or other information. As shown at **350**, the STB **100** displays the interactive session on the screen of TV **80**, and receives viewer commands and interactive responses and sends those signals upstream to the interactive server **5**.

The STB **100**, as indicated at **355**, determines whether the interactive session has been terminated, either at the subscriber's command, or if the end of the interactive application has been reached. If the interactive application has not been terminated, the STB **100** and the interactive server **5** continue providing the functionality in the states shown at points **345** and **350**. If the interactive session has been terminated, the STB **100** at **360** deletes the specific ICA and retrieves from memory the identity of the program channel the subscriber **70** had been viewing and re-tunes to that channel so that the subscriber **70**, at **365**, can continue viewing the broadcast program on that channel.



If at **335** the viewer had not selected the broadcast screen button, **STB 100** would, at **370**, check whether a “remove button” message has been received or whether the timeout period has expired. If not, **STB 100** returns to **335**, checking whether the displayed button has been selected. If a “remove button message” has been received or the timeout period expired, **STB 100** erases the button, at **375**, and deletes the specific ICA. The viewer may then continue viewing the broadcast program at **365**, and the **STB 100**, at **320**, continues listening for a **WKICA** in the **VBI**.

Application-Specific Interactive Callback Address  
Transmitted With Program and Identified by a Non-  
Standard Button Overlay

A third embodiment of a system and method according to the present invention is depicted in **FIGS. 4A** and **4B**. In **FIG. 4A** at **405** an interactive callback address package (**ICAP**) is established for an interactive application associated with a given program. This **ICAP** includes an **ICA** and may also include customized button information. This customized information may include:

- a) type(s) of button(s);
- b) characteristics of button(s);
- c) location on the screen of button(s);
- d) text of button(s); and
- e) other unique characteristics of button(s).

The **ICA** describes a logical address that would map to an interactive server’s network address, includes an application ID, and may include a “timeout” period, which is the time that the button should be displayed on the broadcast screen. As with the first described embodiment, the **ICA** will be used by the **STB 100** to address a call to establish an interactive session associated with the program.

At **410**, the **ICAP** is delivered to a program medium (for instance, a provider of program material such as video tape or live broadcast) and, in a preferred embodiment of the invention, is inserted or stored in the vertical blanking interval (**VBI**) of the desired program associated with the program medium. As an alternative to providing the **ICAP** in the **VBI** of a program, any other synchronized in-band or out-of-band transmission system may be used. The **ICAP** is inserted in the program so that it will appear on the subscriber’s **70** screen at the desired time. In addition to the **ICAP**, a “remove button” message may also be inserted in the **VBI** (or other transmission system) so that the button will be removed at the desired time. If it is desired that the button remain continuously on the viewing screen, the **ICAP** may be inserted at periodic intervals throughout the program.

At **415**, the program is transmitted on a given channel. Along with this program, the **ICA** may be included either in the **VBI**, or transmitted on another in-band or out-of-band transmission system synchronized with the program.

Referring to **FIG. 4B**, an **STB 100** tuned to the channel listens at **420** for the **ICAP** in the **VBI** or other appropriate transmission. At **425**, if an **ICAP** is detected, the **STB 100**, at **430**, uses any customized button information contained in the **ICAP** to generate and overlay a customized button in a customized location over the image. If the **ICAP** does not contain information for a customized button, the **STB 100** uses standard defaults that have been previously stored in the **STB 100**, for example via software download. The **STB 100** sets an internal timer to a timer value sent as part of the **ICAP**, or if no timer value is sent, to a standard timeout value. When the button is being displayed, the **STB 100** listens for the remove button message to remove the button.

If, at **425**, no **ICAP** was detected, the subscriber **70** simply continues watching the program, at **485**, and the **STB 100** continues to listen for the **ICAP**, at **420**.

If the subscriber **70** selects the displayed button, at **435**, the **STB 100**, at **440**, stores in memory the identity of the current channel. The **STB 100** then uses the **ICA** from the **ICAP** it has received to establish an interactive session between the **STB 100** and the appropriate interactive server **5**. The **STB 100** erases the button from the screen, and tunes to the correct channel for the interactive session, which channel was received from the interactive server **5** according to standard protocols when **STB 100** requested an interactive session.

When the interactive session has been established, the interactive server **5**, at **445**, receives upstream information from the **STB 100** and sends video screens, text, graphics, scripts, and/or other information downstream to the **STB 100**. As shown at **450**, the **STB 100** displays the interactive session on the screen of the **TV 80**. The **STB 100** also receives viewer interactive responses and sends responses upstream to the interactive server **5**.

If the interactive session is terminated, which may be a result of the subscriber **70** issuing a termination command, or simply as a result of the completion of the interactive application, **STB 100** detects this event at **455** and, at **460**, deletes the **ICAP** and re-tunes to the channel that was originally being watched and the subscriber **70** continues watching the program on that channel, at **465**. If a termination is not detected, the interactive session continues at **445** and **450**.

If, at **435**, it had been determined by the **STB 100** that the subscriber **70** did not select the displayed button, the **STB 100** determines, at **470**, whether it has received a remove-button message or whether the timer has expired. If neither event has occurred, the **STB 100** continues checking whether viewing subscriber **70** has selected the button, at **435**. If a remove button message has been received at **470**, the **STB 100** erases the button and deletes the **ICAP**, at **475**; if it has not, the **STB 100** at **475** erases the button and deletes the **ICAP** only if a button timeout period has been exceeded, at **470**. After the **STB 100** erases the button and deletes the **ICAP**, the viewing subscriber **70** continues watching the broadcast program, at **465**. Also, the **STB 100** resumes listening for the **ICAP** at **420**.

Application-Specific Interactive Callback Address  
and Button Overlay Both Transmitted With  
Program

In a fourth embodiment of a system and method according to the present invention, the logical flow of which is illustrated at **FIGS. 5A** and **5B**, an application-specific **ICA** is transmitted with the program, along with a button inserted on the video program at the point of transmission.

Referring to **FIG. 5A**, at **505**, an **ICA** is established for a particular interactive application associated with a given program. As with the previously described embodiments, the **ICA** describes a logical address that would map to an interactive server’s network address, includes an application ID, and may include a “timeout” period, which is the time that the button should be displayed on the broadcast screen. The **ICA** ultimately will be used by the **STB 100** of the subscriber **70** viewing the program to invoke an interactive session associated with that program.

At **510**, the **ICA** is delivered to a medium (for instance, a provider of material such as video tape or live broadcast) and, in a preferred embodiment of the invention, it is inserted or stored in the vertical blanking interval (**VBI**) of

the desired program associated with the medium. As an alternative to providing the ICA in the VBI of a program, any other in-band or out-of-band transmission system may be used if it is synchronized with the program. The ICA is inserted into the program so that it will appear at the desired point in the program, and the button is also inserted into the program so that it will appear at that desired time on the screens of all viewers receiving the program, including viewers that are not subscribers and that lack an STB 100. When the button is removed from the program image (and thus the viewers' screens), a "remove button" message is inserted in the VBI. When the STB 100 of a viewing subscriber 70 receives this message, the STB 100 deletes the ICA. The timeout period can be sent with the ICA if the duration of the button display, and hence how long the ICA is to be active, is predetermined.

The program, at 515, is transmitted on a particular channel. As described above in connection with 510, the ICA may either have been incorporated in the transmission, or be sent on an in-band or out-of-band transmission system that is synchronized with the program.

STB 100 at 520 checks for an ICA in the VBI of the video stream (or in another suitable preselected transmission). As indicated at 525, if an ICA is detected, the STB 100 does not overlay a button, at 530, since the button is overlaid at the broadcast source and has appeared on the screen when the ICA arrived at the STB 100. Rather the STB 100 sets the timer and begins checking for a "delete ICA" message or timeout.

If the ICA was not detected, the subscriber 100 simply continues watching the program, at 565.

The STB 100, at 535, checks whether the subscriber 100 has selected the displayed button. If selection of the button is detected, the STB 100 stores the identity of the broadcast channel being viewed. It then uses the ICA to establish an interactive session, at 540, with the appropriate interactive server 5. The STB 100 receives and then tunes to the correct channel for an interactive session.

If, at 535, the subscriber 70 had not selected the button displayed on the screen of the TV 80, the STB 100 continues checking, as shown at 570, whether a "delete ICA" message has been received or if the timer has expired. If either or both these events have occurred, then the STB 100, at 575, deletes the ICA. After 575, the viewer continues watching the program, at 565.

During the interactive session, the interactive server 5, at 545, receives upstream information from the STB 100 and sends video screens, text, graphics, scripts, and/or other information downstream to the STB 100. At 550, the STB 100 displays the interactive session on the screen of the TV 80. It also receives viewer interactive responses and commands and sends them upstream to the interactive server 5.

The STB 100 checks, at 555, whether the interactive session has been terminated. If it has not, the interactive session continues, at 545 and 550. If the session has been terminated, which may have occurred as a result of a command issued by viewing subscriber 70, or due to the end of the interactive application having been reached, the STB 100 deletes the ICA, retrieves the identity of the channel, which subscriber 70 had been watching, and re-tunes to that channel.

The subscriber 70 continues watching the program, at 565. The STB 100 continues to listen for the ICA, at 520, in the VBI or other appropriate transmission.

#### Assignment of Interactive Callback Address

An interactive callback address (ICA) is associated with an interactive application to enable subscribers to invoke an

interactive application, as well as to uniquely identify an interactive application for any number of additional reasons. The ICA describes a logical address that maps to an interactive server's network address, includes an application ID, and may also include a "timeout" period message, which indicates the amount of time that a button indicating the availability of an interactive application or program should be displayed on the broadcast screen. The ICA may be furnished in association with a program to subscribers in a variety of ways, two of which are described below. Once the ICA is received by a subscriber terminal device such as an STB 100, the ICA may be stored so that it will be available at the request of subscriber 70 to call and establish with an interactive server 5 an interactive session associated with a program. The ICA may be assigned in a number of ways, two of which are described below, with reference to FIG. 1, FIG. 6 and FIGS. 7A and 7B.

#### Case I: Locally Assigned Interactive Callback Addresses

When content, such as an interactive news program or a commercial advertisement, is specifically developed for an interactive platform, as may be the case for locally originating programming, a Content Provider 45 requests an ICA from a video service provider 1 operating an interactive server 5 linked to one or more nodes 60 of subscribers 70. This request may be made by any suitable means. It could be done simply by making a telephone call to the video service operator 2, or it could be done by purely electronic means, such as e-mail, or automatically, or remotely invoking an application on the interactive server 5 designed for this purpose. The Content Provider 45 also then transmits to the video service provider 1 the interactive application. This transmission may be done by physically sending the interactive application to the video service provider 1 on tape, magnetic disk, optical disk or other suitable medium; alternatively, it could be done by electronic or optical transmission of the data, such as over a network.

After receiving the request for the ICA, the interactive server 5 assigns an ICA consistent with the state of the interactive server 5 and its memory 8 and other storage devices 8A and 9. The video service provider 1 also stores the application received from the Content Provider in a suitable storage device, such as video storage 9, and stores the ICA and perhaps information relating to the interactive application in a database maintained, for example, in disk storage 8A. Such additional information may include an application ID selected by the video service provider 1.

If the interactive server 5 is called by a subscriber 70 with an ICA, the interactive server 5 may thus retrieve using the ICA any information necessary for locating and running the interactive application. The new ICA may be selected according to any suitable scheme. In one embodiment of the present invention, the ICA has a format of the form shown in FIGS. 7A and 7B. As shown in FIG. 7A, but without limitation, the ICA preferably comprises 32 bits. According to an error correction scheme, such as a Hamming code or other suitable approach, a number of checkbits or parity-type bits are incorporated into the ICA. In FIG. 7A, 6 such bits 110-115 are shown as bits 1, 2, 4, 8, 16, and 32 corresponding to the ICA content shown in FIG. 7B. Hence 38 bits are used to transmit the ICA, with a coding rate of about 0.84. Any error correction schemes suitable for minimizing errors in the transmission of an ICA having a known format may be used.

In FIG. 7B, the components of the ICA are shown. Bits 9-32 contain a program identifier 120, including a server ID

and an application ID. Bits **3–8** are used for an industry code **125**, which is assigned to large Content Providers to uniquely identify them. Bits **1** and **2** correspond to time cycle identifier **130**, which facilitates re-cycling of program identifiers: when a particular application no longer is being provided by the Content Provider identified by a particular industry code, the Content Provider can re-use a particular program identifier. Time cycle identifier **130** is prefixed to ensure uniqueness of the ICA when a program identifier is used an additional time. Where, as shown, the time cycle identifier **130** is allocated two bits, a given program identifier **120** may be used uniquely four times.

When the interactive application has been stored, a new ICA has been selected for the interactive application, and the ICA and interactive application information have been stored in a database, the video service provider **1** or interactive server **5** sends a message to the Content Provider **45**. This message may include a description of the type of application, an ICA confirmation including the ICA itself, an application ID (including a server number and application number), any other information, such as billing information, and a timeout value for specifying the length of time a screen button should persist.

#### Case II: Content-Defined Interactive Callback Addresses

In case I, an interactive application may have been developed for a particular interactive server and was to be assigned an address by that server. As an alternative to case I, interactive applications associated with pre-developed content (that is, created specifically to be associated with the interactive application) may already be associated with and labeled with an ICA by the Content Provider **45**. This may be, but is not necessarily, the case for nationally originating programmers. For such content-defined ICAs, the interactive application and the pre-assigned ICA are both transmitted to the desired video service providers. The transmission may be done simply by shipping a tape, magnetic disk, optical disk or other suitable medium to the video service provider, or alternatively, may be electronically or optically transmitted over a network. The receiving video service provider **1** or interactive server **5** stores the interactive application, then adds the ICA and assigns an application ID. An application ID is an identifier for purposes of internal organization and tracking by the video service provider **1**. Thus, for a nationally originating program in which the ICA identifying the program is national, the interactive server **5** of (local) video service provider **1** translates the (national) ICA to a local server address of its internal database, for example on disk storage **8A**. Once this information has been stored, a receiving video service provider **1** sends a confirmation message to the Content Provider **45**, including what it has recorded as the ICA, the application ID, and a description of the application. As an alternative scheme, not shown in the Figures, the (local) video service provider **1** is linked to a national server running the interactive application, and the local server using the ICA provides a link from the subscriber to the national interactive server.

#### The Interactive Server

One or more interactive servers **5** may be maintained as part of the Level **2** service (**L2**, defined above in connection with FIG. **1**) in order to provide service to subscribers in a particular geographical area. An embodiment of the interactive server **5** according to the present invention may be coupled to one or more transmission paths, such as a satellite

downlink, for receiving programs. The interactive server **5** is also coupled to a level **1** network (**L1**, defined in connection with FIG. **1**), through which it interacts with subscribers **70**, receiving program requests and commands, and sending programming as requested by each subscriber.

An embodiment of an interactive server **5** is shown in FIG. **6**. The interactive server **5** may include, for example, one or more processors **7**, one or more memory devices **8**, and one or more storage devices such as disk storage **8A**. These components may be linked to one another by a data bus **6**. The interactive server **5** may also include a video storage medium **9**, in which device interactive applications supplied by Content Providers may be stored for retrieval upon request by a subscriber **70**.

The interactive server **5** may receive input and provide output to a video service operator, represented schematically at reference numeral **2**, or over data link **11** to the switch **12**, or over data link **3A** directly to a Content Provider **45**. In response to a request by a Content Provider **45** for an ICA to be associated with a program, for example, the video service provider **1** may interact with the interactive server **5** via I/O mechanism **4** in order to obtain an interactive application address, at which an interactive application will be found when stored with the interactive server **5**, and, if necessary, a port address, to combine with the address of the interactive server **5** itself for transmission to the Content Provider **45** via a communication link **3**. Under an alternative scheme, a Content Provider **45** could establish a link with the interactive server **5** itself over communications link **3a** and obtain an ICA directly.

When a video service provider **1** has received an interactive application from a Content Provider **45**, the video service provider **1**, via I/O mechanism **4**, loads the interactive application into an appropriate storage medium, such as video storage **9**, which may be a separate storage medium from the interactive server memory **8** or the interactive server disk storage **8A**, such that the interactive application may be retrieved using the interactive application address portion of the ICA furnished to the Content Provider **45**.

The video service provider **1** may also interact with the interactive server **5** to perform system management functions such as data storage management, if such functions are not carried out automatically.

#### Set Top Box Architecture

A subscriber **70** to an interactive video service will be equipped with an STB **100** for receiving transmissions and initiating an interactive session. The functionality of the STB **100** may reside in a stand-alone device, literally a box that can be placed on, or at least near, the television, that is similar in outward form to conventional devices for receiving cable programs. The STB **100** functionality could alternatively be performed by hardware resident elsewhere, such as within the television or display console, or by any suitably equipped terminal device. Since the hardware may be proprietary to the interactive video provider and may generally be a physically independent device, the term set top box is used here, but the invention is not so limited.

The components of an embodiment of an STB **100** that may be used to implement the system and method according to the present invention are shown in FIG. **8**. STB **100** is coupled to coaxial distribution system **66**, as was briefly described in connection with FIG. **1**. Input to STB **100** received over coaxial distribution system **66** is handled by receiving set components, either analog tuner **1210** or digital tuner/demodulator **1218**. Analog tuner **1210** may be any

conventional tuner suitable for use in receiving video signals over a cable distribution system or the like. Analog signals on coaxial distribution system **66** having a particular carrier frequency are received by analog tuner **1210** if it is tuned to that frequency. Analog tuner **1210** is coupled to secure processor subsystem **1212**. Secure processor subsystem **1212** may be any known system for receiving scrambled or otherwise secured analog signals over a private distribution system. Typically, the secured processor subsystem **1212**, its components, and their functionality are compatible with remote terminal **65** (at the head end of the coaxial distribution system **66** and shown in FIG. 1). Secure processor subsystem **1212** includes a conventional analog descrambler **1216** for descrambling signals received and forwarded by analog tuner **1210**. Secure processor subsystem **1212** also includes a non-volatile memory subsystem **1214** for storing information necessary for decoding received transmissions, including normal cable program transmissions, pay-per-view program transmissions and the like.

Digital signals on cable distribution system **66** are received by digital tuner/demodulator **1218** if they are in a band to which the digital tuner/demodulator **1218** is tuned. Digital tuner/demodulator **1218**, which can be any suitable conventional component, demodulates signals it is tuned to receive in order to reconstruct the desired digitized analog signal. This resulting signal is transmitted to video decoder **1220**, a conventionally available device that interprets the input stream. Video decoder **1220** thereby recovers the compressed signal to produce a video signal.

Analog descrambler **1216** and video decoder **1220** are both coupled to graphics assist module **1222**. Graphics assist module **1222** can be any conventionally available graphics processor suitable for adding a graphics overlay onto the video signals received from the video decoder **1220** and/or the analog descrambler **1216** in response to instructions implemented by software running on CPU **1228**. The functionality of graphics assist module **1222** could be implemented by CPU **1228** if it were suitably programmed and capable of sufficient throughput. As will be further described below, graphics assist module **1222**, in response to instructions received over system bus **1224**, generates a video signal overlaid on the existing television signal indicating the availability of an interactive program. For example, graphics assist module **1222** may generate a button image, or a logo or other pattern or symbol, and inject the image into the video stream such that the image appears in a designated portion of the screen. Information used in generating this button, as described below, may be available in the signal received over coaxial distribution system **66**, or may use information stored in the STB **100**, such as in static memory **1229**, in which the button information may be pre-loaded.

The video stream emerging from analog descrambler **1216** or video decoder **1220**, and from graphics assist module **1222**, is provided to NTSC signal generation module **1226**. As an alternative to NTSC, signal generation module **1226** could generate signals according to any available and desired video format. NTSC signal generation module **1226** is conventional circuitry for transforming the output of analog descrambler **1216**, video decoder **1220** and graphics assist **1222** into the standard form usable by a conventional television or monitor (not shown in this view). This functionality could, alternatively, convert input signals to any suitable standard format. As shown in FIG. 8, NTSC signal generation module **1226** generates a set of coordinated signals and provides them on channel **3** or **4**, **1226A**, to a monitor adapted to receive and display television signals

(not shown). Also transmitted by NTSC signal generation module **1226** to the monitor or television (not shown) is a composite/Svideo Out signal, **1226B**, and left and right audio signals, **1226C**.

In addition to the previously described components and functionality, which have to do with the receipt and provision of television signals, possibly with inserted graphics, STB **100** includes a number of components and implements several additional functions.

The processing associated with managing and controlling the functions of the set top box **100** is performed by CPU **1228**. CPU **1228** may be any suitable commercially available processor and preferably one capable of performing in excess of 30 Mips, such as a Power PC or Pentium chip. In running system software stored in static memory **1229** (which may be an EEPROM, ROM or the like), CPU **1228** has access via system bus **1224** to static memory **1229** and to dynamic memory **1230**, (which may be conventionally available memory, preferably with a storage capacity of at least about 4–5 MB). CPU **1228** also has access via system bus **1224** to information regarding the current channel, to the graphics assist **1222** regarding screen button or other graphical display signals, and to video decoder **1220** and digital tuner/demodulator **1218**, as well as to secure processing subsystem **1212** and analog tuner **1210** in order to assert command messages to those components.

Interaction by subscriber **70** with STB **100** may be by any suitable means, but is preferably by conventional infrared (IR) remote control. IR controller **1232** receives signals from subscriber-controlled remote control input device **1233** via an IR receiver and associated circuitry (not shown). Instructions received by IR controller **1232** may be asserted via system bus **1224** as commands to secure processor subsystem **1212** and analog tuner **1210**, as well as to video decoder **1220** and digital tuner demodulator **1218**. IR controller **1232** can also send messages to CPU **1228** when, for example, subscriber **70** requests an interactive program or other service.

Interaction by the STB **100** upstream via coaxial distribution system **66** and to video service provider **1** is conducted by CPU **1228** through WAN communications processor **1234**. WAN communications processor **1234** can be any conventional device suitable for converting messages received via system bus **1224** into a WAN-compatible protocol, such as IP (internet protocol). Upstream modulator **1236**, which can be any conventional device, modulates signals received from WAN communications processor **1234** for transmission over coaxial distribution system **66** and via remote terminal **65** and network provider **10** to interactive server **5** of video services provider **1** (as shown in FIG. 1).

#### STB Processing Associated with Operation of Several Embodiments of a System According to the Present Invention

In FIGS. 9–12, the processing associated with four embodiments of the STB **100** according to the present invention is shown in the form of diagrams depicting the processing states of the STB **100**, conditions for transitioning between those states and processing associated with each state and incident to the state transitions. The embodiment shown in FIG. 9 corresponds to the embodiment of the invention shown in FIGS. 2A and B, FIG. 10 corresponds to FIGS. 3A and B, FIG. 11 to FIGS. 4A and B, and FIG. 12 to FIGS. 5A and B. The processor states and processing carried out by STB **100** are implemented by CPU **1228**,

shown in FIG. 8. As has been described with reference to that figure, CPU 1228 has access via system bus 1224 to signals received over coaxial distribution system 66 that have been descrambled or decoded as necessary by either of video decoder 1220 or analog descrambler 1216. CPU 1228 is easily capable of sampling these sources sufficiently frequently to detect the receipt of new video frames and to detect the presence and content of information in the VBI of received video signals. In alternate embodiments of the present invention, the STB 100 could receive and analyze information received via other in-band or out-of-band transmission paths.

The processes shown in these figures could also be represented as logic flow diagrams. Moreover, the exact ordering of the numbered boxes of the flowcharts is not a limitation of the invention, but merely an illustration of one way in which the depicted function of each embodiment of this aspect of the present invention may be carried out.

#### STB Processing Where an Application-Specific Interactive Callback Address Is Transmitted With Program and Identified by a Standard Button Overlay

Processes performed by STB 100 in carrying out the first embodiment the system and method according to the present invention are shown in FIG. 9. As shown, the STB 100 process begins when the subscriber 70 turns on the STB 100 to view a program. The STB 100 process at that time initializes into the idle state, 700. While in the idle state 700, the STB 100 checks a number of conditions: it checks whether a video frame has been received; whether a screen button has been selected by viewing subscriber 70; whether a "remove button" message has been received with a video frame; and whether a button timer has exceeded a threshold value and thus expired.

If a video frame has been received, 702, STB 100 enters a new state, 704, in which it tests the video frame, particularly the VBI of that frame, for the presence of an ICA. As described elsewhere in this application, according to the present invention, the ICA could alternatively be transmitted to the STB 100 by any suitable in-band or out-of-band means.

If no ICA is detected in the given frame by STB 100 at 706, the process returns to idle state 700. However, if an ICA is detected in the received frame at 708, STB 100 at 710 stores the ICA, for example in dynamic memory 1230 (shown in FIG. 8). STB 100 then enters a new state, 712.

In state 712, STB 100 tests the detected ICA for the presence of information relating to the drawing of a screen button to indicate to viewing subscriber 70 that an interactive program is available. If such information related to the configuration of the screen button is found, at 718, then STB 100 draws a custom button according to this information, at 720. Also at 720, STB 100 sets a timer for the screen button, which STB 100 will check to ensure that the button remains on the screen no longer than a desired maximum time. If the button information was not found in the ICA, 714, then STB 100 at 716 draws a standard button on the basis of information stored in static memory 1229, shown in FIG. 8. STB 100 at 716 also sets the timer to be later checked in order to ensure that the standard screen button is timely erased. After the button is drawn and the timer is set at 716 or 720, idle state 700 is resumed.

When in the idle state 700, in addition to testing whether a video frame has been received, as described above, STB 100 also tests whether a screen button, if present on the

screen, has been selected by subscribing viewer 70. STB 100 can access this information available from IR controller 1232 via system bus 1224, as shown in FIG. 8. If a button has been selected, 722, STB 100, at 724, saves in dynamic memory 1230 (shown in FIG. 8) the identity of the channel currently being viewed by subscriber 70. STB 100 at 724 also erases the screen button, which provides feedback to subscriber 70 that the button has been selected.

After the channel has been saved and the button erased at 724, STB 100 enters the interactive application state 726. In interactive application state 726, STB 100 establishes an interactive session with interactive server 5 of video service provider 1 over the network by sending a message containing the ICA using WAN communications processor 1234 and upstream modulator 1236 (shown in FIG. 8 and described above) over coaxial distribution system 66, and via remote terminal 65 and network service provider 10 to interactive server 5 of video service provider 1 (shown in FIG. 1).

STB 100 remains in the interactive application state 726 as long as the interactive application invoked by the ICA and provided by video service provider 1 has not ended or been terminated by subscribing viewer 70 via IR controller 1232. If either of these events are detected by STB 100 at 728, however, STB 100 at 730 retrieves from dynamic memory 1230 the earlier-stored identity of the channel originally being watched and issues a command to either video decoder 1220 and digital tuner/demodulator 1218 or secure processor subsystem 1212 and analog tuner 1210 to re-tune to that original channel. Also at 730, STB 100 deletes the ICA from dynamic memory 1230. STB 100 then returns to the idle state 700.

While in idle state 700, and in addition to testing for the reception of video frames and whether a screen button has been selected, STB 100 also checks, when a video frame has been received at 702, but no ICA has been detected at 706, for a "remove button" message in the VBI of the video frame (or in any other suitable in-band or out-of-band signalling path). STB 100 also periodically checks whether the timer, set at 716 or 720, has expired. If either a "remove button" message has been received or the expiration of the timer has been detected, at 732, then STB 100, at 734, erases the screen button and deletes the ICA from dynamic memory 1230, if one had been previously stored. STB 100 then returns to its idle state 700 and continues checking for video frames, the selection of a screen button, remove button messages and timer expirations.

#### STB Processing Where a Well-Known Interactive Callback Address Is Transmitted With a Program and Identified by Standard Button Overlay

In FIG. 10, processes performed by STB 100 in connection with a second embodiment of the system and method according to the present invention are shown in state diagram form. The STB 100 process begins when the subscriber 70 turns on the STB 100 to view a program. The STB process initializes into the idle state, 800. While in the idle state 800, the STB 100 checks a number of conditions: it checks whether a video frame has been received; whether a screen button has been selected by viewing subscriber 70; whether a "remove button" message has been received with a video frame; and whether a button timer has exceeded a threshold value and thus expired.

If a video frame has been received, at 802, STB 100 enters a new state, 804. In this state, it tests the video frame, particularly the VBI of that frame, for the presence of a

WKICA (i.e., a well-known interactive callback address, described above) associated with the program being viewed. As discussed elsewhere in this application, according to the present invention, the WKICA could alternatively be transmitted to the STB 100 by any suitable in-band or out-of-band means.

If STB 100 detects at 806 no WKICA in the given frame, the process returns to state 800. However, if a WKICA is detected in the received frame, at 808, STB 100, at 810, stores the WKICA, for example in dynamic memory 1230 (shown in FIG. 8). STB 100 then calls the WKICA, establishes an interactive session with the WKICA, and sends the WKICA application the identity of the broadcast channel on which it received the WKICA. STB 100 then receives from the WKICA application the specific ICA, which it must call if the associated button on the screen is selected. STB 100 stores the ICA, for example in dynamic memory 1230 (shown in FIG. 8) and then enters a new state, 812.

In state 812, STB 100 tests information downloaded from the WKICA interactive session for the presence of information relating to the drawing of a screen button to indicate to viewing subscriber 70 that an interactive program is available. If such information related to the configuration of the screen button is found, at 818, then STB 100 draws a custom button according to this information, at 820. Also at 820, STB 100 sets a timer for the screen button, which it will check to ensure that the button remains on the screen no longer than a desired maximum time. If the button information was not received from the WKICA interactive session, at 814, then STB 100, at 816, draws a standard button on the basis of information stored in static memory 1229, shown in FIG. 8. STB 100, at 816, also sets the timer to be later checked in order to ensure that the standard screen button is timely erased. After the button is drawn and the timer is set at 816 or 820, idle state 800 is resumed.

When in the idle state 800, in addition to testing whether a video frame has been received, as described above, STB 100 also tests whether a screen button, if present on the screen, has been selected by viewing subscriber 70. STB 100 can access this information, available from IR controller 1232, via system bus 1224, as shown in FIG. 8. If a button selection has been selected, 822, STB 100 at 824 saves in dynamic memory 1230 (shown in FIG. 8) the identity of the channel currently being viewed by subscriber 70. STB 100, at 824, also erases the screen button, thus providing feedback to subscriber 70 that the button has been selected.

After the channel has been saved and the button erased, at 824, STB 100 calls the specific ICA and enters the interactive application state, 826. In interactive application state 826, STB 100 initiates an interactive session with interactive server 5 of video service provider 1 over the network by sending a message containing the ICA using WAN communications processor 1234 and upstream modulator 1236 (shown in FIG. 8 and described above) over coaxial distribution system 66, and via remote terminal 65 and network service provider 10 to interactive server 5 of video service provider 1 (shown in FIG. 1).

STB 100 remains in the interactive application state 826 as long as the interactive application invoked by the ICA and provided by video service provider 1 has not ended or been terminated by subscribing viewer 70 via IR controller 1232. If either of these events are detected by STB 100, at 828, at 830 it retrieves from dynamic memory 1230 the earlier-stored identity of the channel originally being watched and issues a command to either video decoder 1220 and digital tuner/demodulator 1218 or secure processor subsystem 1212

and analog tuner 1210 to re-tune to that original channel. Also at 830, STB 100 deletes the ICA from dynamic memory 1230. STB 100 then returns to the idle state 800.

In addition to testing in idle state 800 for the reception of video frames and whether a screen button has been selected, STB 100 also conducts a further check. If, at 802, a video frame has been received, but no WKICA has been detected at 806, STB 100 checks for a "remove button" message in the VBI of the video frame (or in any other suitable in-band or out-of-band signalling path). STB 100 also periodically checks whether the timer, set at 816 or 820, has expired. If either a "remove button" message has been received or the expiration of the timer has been detected, at 832, then STB 100, at 834, erases the screen button and deletes the ICA from dynamic memory 1230, if one had been previously stored. STB 100 then returns to its idle state 800 and continues checking for video frames, the selection of a screen button, remove button messages and timer expirations.

#### STB Processing Where an Application-Specific Interactive Callback Address Package Is Transmitted With Program and Identified by a Non-Standard Button Overlay

A third embodiment of the processing performed by STB 100 in implementing the system and method according to the present invention is shown in FIG. 11. The STB 100 process begins when the subscriber 70 turns on the STB 100 to view a program. The STB 100 process initializes into the idle state, 900. While in the idle state, 900, the STB 100 checks a number of conditions: it checks whether a video frame has been received; whether a screen button has been selected by viewing subscriber 70; whether a "remove button" message has been received with a video frame; and whether a button timer has exceeded a threshold value and thus expired.

If a video frame has been received, at 902, STB 100 enters a new state, 904, in which it tests the video frame, particularly the VBI of that frame, for the presence of an ICAP associated with the program being viewed. As described above in connection with FIGS. 4A and 4B, an ICAP is an interactive callback address package, described above as optionally including non-standard or customized button information such as: a) type(s) of buttons; b) description of buttons; c) location of button(s) on screen; d) text of button(s); and e) other characteristics of buttons. As discussed elsewhere in this application, according to the present invention, the ICAP could alternatively be transmitted to the STB 100 by any suitable in-band or out-of-band means.

If STB 100, at 906, detects no ICAP in the given frame, the process returns to state 900. However, if an ICAP is detected in the received frame, at 908, STB 100 at 910 stores the ICAP, for example in dynamic memory 1230 (shown in FIG. 8). STB 100 then enters a new state, 912.

At 912, STB 100 tests the detected ICAP for the presence of custom information relating to the drawing of a screen button to indicate to viewing subscriber 70 that an interactive program is available. If such information related to the configuration of the screen button is found, at 918, then STB 100 draws a custom button according to this information, at 920. Also at 920, STB 100 sets a timer for the screen button, which it will check in order to ensure that the button remains on the screen no longer than a desired maximum time. If the button information was not found in the ICAP, at 914, then STB 100, at 916, draws a standard button on the basis of

information stored in static memory 1229, shown in FIG. 11. STB 100, at 916, also sets the timer to be later checked in order to ensure that the standard screen button is timely erased. After the button is drawn and the timer is set at 916 or 920, idle state 900 is resumed.

When in the idle state 900, in addition to testing whether a video frame has been received, as described above, STB 100 also tests whether a screen button, if present on the screen, has been selected by subscribing viewer 70. STB 100 can access this information, available from IR controller 1232, via system bus 1224, as shown in FIG. 8. If a button has been selected, 922, STB 100 at 924 saves in dynamic memory 1230 (shown in FIG. 8) the identity of the channel currently being viewed by subscriber 70. STB 100, at 924, also erases the screen button, thus providing feedback to subscriber 70 that the button has been selected.

After the channel has been saved and the button erased, at 924, STB 100 enters the interactive application state, 926. In interactive application state 926, STB 100 establishes an interactive session with interactive server 5 of video service provider 1 over the network by sending a message containing the ICAP using WAN communications processor 1234 and upstream modulator 1236 (shown in FIG. 8 and described above) over coaxial distribution system 66, and via remote terminal 65 and network service provider 10 to interactive server 5 of video service provider 1 (shown in FIG. 1).

STB 100 remains in the interactive application state, 926, as long as the interactive application invoked by the ICAP and provided by video service provider 1 has not ended or been terminated by subscribing viewer 70 using IR controller 1232. If either of these events are detected by STB 100, at 928, STB 100, at 930, retrieves from dynamic memory 1230 the earlier-stored identity of the channel originally being watched and issues a command to either video decoder 1220 and digital tuner/demodulator 1218, or to secure processor subsystem 1212 and analog tuner 1210 to re-tune to that original channel. Also at 930, STB 100 deletes the ICAP from dynamic memory 1230. STB 100 then returns to the idle state 900.

In addition to testing in idle state 900 for the reception of video frames and whether a screen button has been selected, STB 100 also conducts a further check. If, at 902, a video frame has been received but no ICAP has been detected, at 906, STB 100 checks for a "remove button" message in the VBI of the video frame (or in any other suitable in-band or out-of-band signalling path). STB 100 also periodically checks whether the timer, set at 916 or 920, has expired. If either a "remove button" message has been received or the expiration of the timer has been detected at 932, then STB 100 at 934 erases the screen button and deletes the ICAP from dynamic memory 1230, if one had been previously stored. STB 100 then returns to its idle state 900 and continues checking for video frames, the selection of a screen button, remove button messages and timer expirations.

#### STB Processing Where an Application-Specific Interactive Callback Address and Button Overlay Are Both Transmitted With the Program

Referring to FIG. 12, processing by STB 100 in connection with the fourth embodiment of the system and method according to the present invention is shown. In this embodiment, the button indicating the availability of an interactive program is inserted into the signal at its point of origin and thus need not be overlaid by STB 100.

The STB 100 process begins when the subscriber 70 turns on the STB 100 to view a program. The STB 100 process initializes into the idle state, 1000. While in the idle state, 1000, the STB 100 checks a number of conditions: it checks whether a video frame has been received; whether a screen button has been selected by viewing subscriber 70; and whether a timer has expired by exceeding a threshold value.

If a video frame has been received, 1002, STB 100 enters a new state, 1004, in which it tests the video frame, particularly the VBI of that frame, for the presence of an ICA associated with the program being reviewed. As discussed elsewhere in this application, according to the present invention, the ICA could alternatively be transmitted to the STB 100 by any suitable in-band or out-of-band means.

If STB 100 detects, at 1006, no ICA in the given frame, the process returns to the idle state, 1000. However, if an ICA is detected in the received frame, 1008, STB 100, at 1010, stores the ICA, for example in dynamic memory 1230 (shown in FIG. 8). STB 100, also at 1010, sets the timer. The STB 100 then returns to the idle state, 1000. No button needs to be drawn, since a button will be present, if at all, in the received broadcast signal and thus on the screen.

When in the idle state, 1000, in addition to testing whether a video frame has been received, as described above, STB 100 also tests whether a screen button, if present on the screen, has been selected by subscribing viewer 70. STB 100 can access this information, available from IR controller 1232, via system bus 1224, as shown in FIG. 8. If a button has been selected, at 1012, STB 100, at 1014, saves in dynamic memory 1230 (shown in FIG. 8) the identity of the channel currently being viewed by subscriber 70. STB 100, at 1014, need not erase the screen button, since it was not responsible for overlaying the button. Rather, at the desired time, the button is removed at the point of origin, where it was inserted into the video stream.

After the channel has been saved at 1014, STB 100 enters the interactive application state, 1016. In the interactive application state, 1016, STB 100 establishes an interactive session with interactive server 5 of video service provider 1 over the network by sending a message containing the ICA. STB 100 sends the message containing the ICA using WAN communications processor 1234 and upstream modulator 1236 (shown in FIG. 8 and described above) over coaxial distribution system 66, and via remote terminal 65 and network service provider 10 to interactive server 5 of video service provider 1 (shown in FIG. 1).

STB 100 remains in the interactive application state 1016 as long as the interactive application invoked by the ICA and provided by video service provider 1 has not ended or been terminated by subscribing viewer 70 using IR controller 1232. If either of these events are detected by STB 100, at 1018, however, STB 100 at 1020 retrieves from dynamic memory 1230 the earlier-stored identity of the channel originally being watched. STB 100 then also issues a command to either video decoder 1220 and digital tuner/demodulator 1218, or to secure processor subsystem 1212 and analog tuner 1210, to re-tune to the original channel. Also at 1020, STB 100 deletes the ICA from dynamic memory 1230. STB 100 then returns to the idle state 1000.

In addition to testing in idle state 1000 for the reception of video frames and whether a screen button has been selected, STB 100 also conducts a further check. If at 1002 a video frame has been received but no ICA has been detected at 1006, STB 100 checks periodically whether the timer, set at 1010, has expired. If either the screen button has been removed from the broadcast image at its source or the

expiration of the timer has been detected at **1022**, then STB **100** at **1024** deletes the ICA from dynamic memory **1230**, if one had been previously stored. STB **100** then returns to its idle state **1000** and continues checking for video frames, the selection of a screen button, remove button messages and timer expirations.

#### Signalling Between the Set Top Box and the Interactive Server Associated with Establishing an Interactive Session

When a subscriber **70** has seen an icon or button on the screen during a particular program, and wishes to view the interactive application, he or she “pushes the button” by sending the appropriate signal to the STB **100** using a suitable user input device, such as IR remote input device **1233**. The signal may be any preselected signal the input device is capable of generating, and the STB **100** is capable of receiving. It could, for example, be one or more existing keys on the IR remote input device **1233**. When the STB **100** receives this preselected signal while in state **712**, **812**, **912** or **1012**, depending on the embodiment (in which state STB **100** tests for the selection of a button by viewing subscriber **70**, as described), the STB **100** saves the present channel number in dynamic memory **1230**, initiates an application for setting up an interactive session, including sending a session request message to the network service provider **10**. As defined above, the L1 service, or video dial tone, provided by network service provider **10** represents the data communications phase of a system for providing video services and is the part of that system that is regulated by the FCC. As described above in connection with FIG. **1**, the network service provider **10** operates the following components: the switch **12**, the network controller **16**, the signal processing equipment **14**, and the RF equipment **25**, and interfaces with the distribution network **50**.

The network service provider **10** at the request of STB **100**, is responsible for establishing a session between STB **100** and the interactive server **5**. If a connection with the interactive server **5** is properly established by the network service provider **10** and the interactive server **5** is up and capable of conducting an interactive session, the interactive server **5** sends a session accept message back to the network service provider **10**, which in turn sends a session accept message to the STB **100**.

Once the STB **100** has received the session accept message from the interactive server **5** by way of the network service provider **10**, it uses the ICA to send an application ID request message directly via the network service provider **10** (i.e., the network service provider **10** service needs only to transmit but not process the message) indicating the application server **5** with which the session is requested. The network service provider **10** sets up an interactive session with the indicated interactive server **5** and sends a confirmation to the STB **100**. When it has received this confirmation the STB **100** issues a request to the network service provider **10** to connect with the interactive server **5**. The network service provider **10** then notifies the interactive server **5** of the request. If the interactive server **5** is able to respond to the request, the network service provider **10** establishes a connection between the interactive service **5** and the STB **100**, and the interactive session proceeds.

The foregoing describes a preferred embodiment of the present invention. Various changes and modifications to what is disclosed may be adopted or implemented without departing from the scope or spirit of the invention.

What is claimed is:

**1.** A device for switching from a first program transmitted over a first channel to a second program transmitted over a second channel upon receiving a signal indicating the availability of the second program and upon selection by a user, comprising:

a receiving set, having at least one receiver, for receiving the program on the first channel, and for receiving the signal indicating availability of the second program, and capable of being adjusted from receiving the first program on the first channel to receiving the second program over the second channel; and

a processor, coupled to the receiving set and adapted to receive a selection signal originating with the user, the processor being programmed to process transmissions received by the receiving set to detect the signal indicating the availability of the second program, and to cause the receiving set to adjust to the second channel to receive the second program upon receiving a selection signal from the user; and

a memory means coupled to the processor, and wherein the processor is further programmed to:  
store the identity of the channel of the first television program in the memory means prior to causing the receiver to adjust to the second channel;  
retrieve the identity of the first channel from the memory means at a desired time; and  
cause the receiving set to re-adjust to the first channel to receive the first program.

**2.** The device of claim **1**, in which the signal indicating the availability of the second channel is included in the first program transmission, wherein the processor is further programmed to derive the signal indicating the availability of the second program channel from the first program transmission.

**3.** The device of claim **2**, wherein the signal indicating the availability of the second program is included in a vertical blanking interval of the first program transmission, the processor being further programmed to derive the signal indicating the availability of the second program channel from the vertical blanking interval of the first program.

**4.** A device for allowing a viewer to switch a display device from a first program transmitted over a first channel to a second program transmitted over a second channel upon receiving a signal indicating the availability of the second program, the device coupled to a display means, comprising:

a receiving set, having at least one receiver, for receiving a program on the first channel, and for receiving the signal indicating availability of the second program and capable of being adjusted from receiving the first program on the first channel to receiving the second program over the second channel;

means for receiving a viewer request that the device switch to the second program; and

a processor, coupled to the receiver, to the means for receiving a viewer request, and to the display means, and programmed to:

process transmissions received by the receiving set to detect the signal indicating the availability of the second program;

generate a message indicative of the availability of the second program and display the message on the display means;

receive a viewer request that the device switch to the second program;

upon receipt of the viewer request, store the identity of the channel of the first television program in the



## 31

memory means and cause the receiving set to adjust to the second channel to receive the second program; retrieve the identity of the first channel at a desired time; and cause the receiving set to readjust to the first channel to receive the first program.

5. The device of claim 4, wherein the signal indicating the availability of the second program channel is included in the first program transmission, the processor being further programmed to:

derive the signal indicating the availability of the second program channel from the first program transmission.

6. The device of claim 4, further comprising at least one information storage device coupled to the processor.

7. The device of claim 6, wherein information for generating a message indicative of the availability of the second program, for display on the display means, is pre-stored in one of the at least one information storage devices, and wherein the processor is further programmed to generate the message using the pre-stored information.

8. A device for allowing a viewer to switch a display device from a first program transmitted over a first channel to a second program transmitted over a second channel upon receiving a signal indicating the availability of the second program, the device coupled to a display means, comprising:

a receiving set, having at least one receiver, for receiving a program on the first channel, and for receiving the signal indicating availability of the second program and capable of being adjusted from receiving the first program on the first channel to receiving the second program over the second channel;

means for receiving a viewer request that the device switch to the second program; and

a processor, coupled to the receiver, to the means for receiving a viewer request, and to the display means, and programmed to:

process transmissions received by the receiving set to detect the signal indicating the availability of the second program;

generate a message indicative of the availability of the second program and display the message on the display means;

receive a viewer request that the device switch to the second program; and

upon receipt of the viewer request, cause the receiving set to adjust to the second channel to receive the second program;

at least one information storage device coupled to the processor; and

wherein the processor is further programmed to:

store the identity of the first channel in one of the at least one information storage devices prior to causing the receiving set to adjust to the second channel;

retrieve the identity of the first channel from the storage device at a desired time; and

cause the receiving set to re-adjust to the first channel to receive the first program.

9. A device for use with a display device to allow a viewer of a first program transmitted over a first channel to switch to a second channel to receive an interactive program on receipt of a signal indicative of at least the availability of and identifying code for the interactive program, the viewer being equipped with an input means for issuing the request, the device comprising:

a receiving set adapted for receiving transmissions on the first channel, for being adjusted from receiving trans-

## 32

missions over the first channel to receiving an interactive program over the second channel and, further, for receiving the transmission carrying the signal indicative of the availability of an identifying code for said interactive program;

means for receiving viewer input from said viewer input means;

means for generating a video signal carrying a desired image and for combining said signal carrying said image with a signal being received by the receiver for viewing on the display device;

processing means coupled to the receiving set, to the means for generating a video signal, and to the means for receiving viewer-input, and programmed to:

detect the signal indicative of the availability of an identifying code for the interactive program;

cause the means for generating a video signal to generate a signal indicative of the availability of the interactive program and combine said indicative signal with the signal being received by the receiving set,

detect a signal received by the means for receiving viewer input indicative of a viewer request to view the second transmission; and

cause the receiving set to adjust to the second channel to receive the interactive program for viewing on the display device.

10. The device of claim 9, further comprising a memory means coupled to the processor and wherein information for use in generating a visual indication of the availability of the interactive program is stored in the memory means, and the means for generating a video signal for display on the display device indicative of the availability of the interactive program transforms the information stored in the memory means in order to generate the visual indication of the availability of the interactive program.

11. The device of claim 9, further comprising memory means coupled to the processor and wherein the processor is further adapted to store the identity of the first channel prior to causing the receiving set to adjust to the second channel to receive the interactive program.

12. The device of claim 11, wherein the processor is further programmed to retrieve the identity of the first channel upon termination of the interactive program, and to cause the receiving set to re-adjust to receive said transmission over the first channel for viewing on the display device.

13. A method for allowing a viewer equipped with a television signal receiving device coupled to a display device to switch between a first television program on a first channel and a second television program on a second channel, wherein a signal transmitted in association with the first television program indicates that the second television program is available, wherein the viewer is equipped to receive the second television program upon request, and wherein the television signal receiving device is adapted for receiving viewer requests, comprising the steps of:

a. receiving the first television program;

b. receiving the signal transmitted in association with the first television program indicating the availability of the second television program;

c. generating an image, based on receipt of the signal indicating the availability of the second television program, for displaying on the display device to notify the television viewer of that availability;

d. receiving a viewer request to switch to the second program;

- e. switching to the second channel to receive the second program;
- f. storing the identity of the first channel;
- g. retrieving the identity of the first channel at a desired time; and
- h. causing the receiving device to readjust to the first channel to receive the first program.

**14.** The method of claim **13**, in which the signal transmitted in association with the first television program is incorporated in the vertical blanking interval of said first television program, further comprising the step of deriving the signal from the vertical blanking interval after receiving said signal transmitted in association with the first television program and prior to generating an image based on receipt of said signal transmitted in association with the first television program.

**15.** The method of claim **13**, wherein the step of generating the image for display on the display device to indicate the availability of the second program includes operation only upon information in the signal transmitted in association with the first television program.

**16.** The method of claim **13** in which the television signal receiving device includes a memory, wherein the step of generating an image based on receipt of the signal indicating the second television program is available includes reading information from the memory and using the information read from memory in generating the image.

**17.** A method for switching between a television program and an interactive program, wherein the television program signal is accompanied by a signal carrying a message providing an identification code for an associated interactive program available on an interactive server on a network, and the viewer is equipped with means for receiving the television signal, means for receiving the message indicating that an interactive program is available, display means, means for generating and overlaying an image on the display means, information storage means, means coupled to the network for communicating with the interactive server, and input means coupled to the means for communicating with the interactive server for requesting the interactive television program, the method comprising the steps of:

- a. receiving the television program signal;
- b. receiving the signal carrying the message providing the interactive program identification code;
- c. generating an image for display on the television screen indicative of the availability of an interactive program;
- d. receiving a signal from the input means requesting the interactive program;
- e. storing the identity of the channel on which the television program is transmitted in said information storage means for later retrieval;
- f. establishing communication with the interactive server over the network using the identification code;
- g. receiving the interactive program over the network from the interactive server;
- h. terminating communication with the interactive server upon the earlier of the termination of the interactive program or a viewer request to terminate;
- i. retrieving the identity of the television program channel from said information storage means; and
- j. tuning the means for receiving television signals to the channel having the identity retrieved from the information storage means.

**18.** A system for providing programs and interactive programs to a set of viewers to which the system is coupled

by a distribution system, including receiving programs from at least one program provider via a first transmission path, receiving interactive programs from at least one interactive program provider via a second transmission path, receiving over a distribution system to which the system and the viewer communications means are coupled viewer requests for interactive programs, and providing over the distribution system interactive programs to viewers who have requested such content, comprising:

a switch for receiving and routing program and interactive program transmissions from the at least one program provider over the transmission media, and for receiving and routing viewer requests;

distribution system interface equipment coupled to the switch for allowing the switch to route programs to and receive requests from viewers over the distribution system; and

an interactive server coupled to the switch for receiving and managing interactive programs received from interactive program providers and for responding to viewer requests for the interactive programs, said server comprising a processor programmed to:

- receive from an interactive program provider a request for an identifying code corresponding to an interactive program;
- assign an identifying code to an interactive program provided by an interactive program provider; and
- transmit the identifying code to the interactive program provider over the first transmission path.

**19.** The system of claim **18**, wherein the distribution system interface equipment comprises a network controller, signal processing equipment, and RF equipment.

**20.** The system of claim **19**, wherein the distribution system interface equipment further comprises electrical/optical converting equipment.

**21.** The system of claim **18**, wherein the interactive server further comprises a video storage device for storing interactive programs and a data storage device for storing identifying codes and data associating video storage device locations for the interactive programs with the corresponding identifying codes, and wherein the processor is further programmed to:

- receive the interactive program;
- store the interactive program at a known location in the video storage device;
- associate the identifying code for an interactive program with the location in the video storage device at which the interactive program is stored; and
- store the association of the identifying code and the location in video storage in the data storage device.

**22.** The system of claim **21**, wherein the processor is further programmed to

- receive over the distribution system from a viewer a first message including an identifying code for an interactive program; and
- send over the distribution system to the viewer a second message indicative of a channel on which the program will be transmitted to the viewer over the network; and
- transmit the program over the distribution system to the viewer over the indicated channel.

**23.** A system for providing programs and interactive programs to a set of viewers to which the system is coupled by a distribution system, including receiving programs from at least one program provider via a first transmission path, receiving interactive programs from at least one interactive

## 35

program provider via a second transmission path, receiving over a distribution system to which the system and the viewer communications means are coupled viewer requests for interactive programs, and providing over the distribution system interactive programs to viewers who have requested such content, comprising:

a switch for receiving and routing program and interactive program transmissions from the at least one program provider over the transmission media, and for receiving and routing viewer requests;

distribution system interface equipment coupled to the switch for allowing the switch to route programs to and receive requests from viewers over the distribution system; and

an interactive server coupled to the switch for receiving and managing interactive programs received from interactive program providers and for responding to viewer requests for the interactive programs;

wherein the interactive server comprises a processor programmed to:

receive a request for an identifying code corresponding to an interactive program;

assign a common identifying code to an interactive program provided by an interactive program provider; and

transmit the common identifying code to the interactive program provider over the first transmission path.

**24.** A method of operating a video service system for delivering a program over a network to a subscriber upon request, the video service system including an information storage device, comprising the steps of:

receiving over a network from a subscriber a first message including a first identifying code indicative of the location in the information storage device of a program;

sending over the network to the subscriber a second message indicative of a channel on which the program will be transmitted to the subscriber over the network;

transmitting the program to the subscriber over the indicated channel;

generating a remove button message; and

transmitting the remove button message to the subscriber.

**25.** The method of claim **24**, wherein the remove button message is transmitted to the subscriber in the vertical blanking interval of the interactive program.

**26.** The method of claim **24**, wherein the remove button message is transmitted to the subscriber via out-of-band signalling.

**27.** A method of operating a video service system for delivering a program originating with a Content Provider over a network to a subscriber upon request, the video service system including at least one information storage device, comprising the steps of:

receiving a request for an identifying code from a Content Provider;

providing an identifying code, associated with a location in the information storage device, to the Content Provider;

receiving a program from the Content Provider;

storing the program in an information storage device at a known location;

## 36

associating the identifying code with the location of the program in an information storage device;

receiving over a network from a subscriber a first message including an identifying code indicative of the location in the information storage device of a program;

sending over the network to the subscriber a second message indicative of a channel on which the program will be transmitted to the subscriber over the network; and

transmitting the program to the subscriber over the indicated channel.

**28.** A method of supplying interactive programming to a plurality of subscribers, comprising the steps of:

a. in a video information provider server, identifying available interactive programming stored on a content provider platform and address information relating to the location in which such programming is stored;

b. supplying to said subscribers first, television programming;

c. supplying to said subscribers contemporaneously with said first programming, said address information for at least a portion of said interactive programming;

d. in a set top box located on the premises of at least one of said subscribers, and at a time when said address information is being supplied, generating an image and overlaying said image on said subscriber's display of said first programming to indicate the availability of said interactive programming;

e. at a time when said subscriber selects said image, transmitting said address information to a telecommunications switch, receiving said address information in said server, accessing said portion of said interactive programming using said server, supplying said portion to said subscriber's set top box through said telecommunications switch and displaying said portion on subscriber's display.

**29.** A method according to claim **28** in which the interactive programming portion is accessed using said address information.

**30.** A method according to claim **28** in which said address information is supplied to said subscribers by said content provider.

**31.** A method according to claim **28** in which at least a portion of said interactive programming is supplied by a service which also supplies at least a portion of said first programming.

**32.** A method according to claim **31** in which said address information for said portion of said interactive programming is supplied to said subscribers by said service.

**33.** A method according to claim **28** in which said first and interactive programming is provided to subscribers via said telecommunications switch.

**34.** A method according to claim **28** in which said interactive programming is supplied to said subscriber in a session in which said subscriber may interact with said programming through said telecommunications switch by communicating with the supplier of said interactive programming.

**35.** A method according to claim **28** in which at least a portion of said interactive programming is video programming.

**37**

**36.** A method according to claim **35** in which at least a portion of said interactive programming is digital video programming.

**37.** A method according to claim **28** in which at least a portion of said interactive programming is formed of packet switched information.

**38.** A method according to claim **28** in which said address information is supplied to said subscribers in the vertical blanking interval of said television programming.

**38**

**39.** A method according to claim **28** in which said address information is supplied to said subscribers in a subcarrier.

**40.** A method according to claim **28** in which said address information is supplied by modulating the signal carrying said television programming with digital information corresponding to the address information, and demodulating the signal at the set top box to extract the address information.

\* \* \* \* \*