



US005599127A

United States Patent [19]

[11] Patent Number: **5,599,127**

Fuhrmann, III et al.

[45] Date of Patent: ***Feb. 4, 1997**

[54] CAP FOR WRITING AND MARKING INSTRUMENTS

[75] Inventors: **Arthur D. Fuhrmann, III**, Northford; **Craig Stevens**, Bethany; **Glenn Gramolini**, Ansonia, all of Conn.

[73] Assignee: **BIC Corporation**, Milford, Conn.

[*] Notice: The portion of the term of this patent subsequent to Nov. 13, 2011, has been disclaimed.

4,969,766	11/1990	Nagle et al. .	
4,988,227	1/1991	Imazu .	
5,000,603	3/1991	Isoda .	
5,000,604	3/1991	Isoda .	
5,051,015	9/1991	Moeck	401/202
5,054,949	10/1991	Heger .	
5,061,105	10/1991	Isoda .	
5,066,156	11/1991	Petrillo et al. .	
5,073,056	12/1991	Belmondo .	
5,076,721	12/1991	Belmondo .	
5,114,258	5/1992	Yasunaga .	
5,127,754	7/1992	Mase .	
5,176,460	1/1993	Garry .	
5,203,637	4/1993	Nishimura et al. .	

[21] Appl. No.: **295,472**

FOREIGN PATENT DOCUMENTS

[22] Filed: **Aug. 24, 1994**

Related U.S. Application Data

[63] Continuation of Ser. No. 78,581, Jun. 16, 1993, abandoned, which is a continuation of Ser. No. 791,895, Nov. 13, 1991, Pat. No. 5,230,578.

[51] Int. Cl.⁶ **B43K 9/00**

[52] U.S. Cl. **401/202; 401/213; 401/243**

[58] Field of Search **401/202, 213, 401/243, 247; D19/43, 57, 58**

2061438	8/1993	Canada .	
2042225A1	12/1986	European Pat. Off. .	
0319311B1	6/1989	European Pat. Off. .	
330877A2	9/1989	European Pat. Off. .	
3728896C1	6/1988	Germany .	
3817248	10/1989	Germany	401/202
139593	9/1989	Japan	401/202
22887	2/1990	Japan	401/202
782159	9/1957	United Kingdom .	
2215279A	9/1989	United Kingdom .	
2218381	11/1989	United Kingdom .	
2220199	1/1990	United Kingdom .	
2229967	10/1990	United Kingdom .	
2246744	2/1992	United Kingdom .	
2233607	11/1992	United Kingdom .	
8911978	12/1989	WIPO .	

[56] References Cited

U.S. PATENT DOCUMENTS

D. 249,888	10/1978	Barnes .	
D. 252,691	8/1979	Malm et al. .	
258,217	2/1981	Sakaoka .	
D. 273,398	4/1984	Zierhut .	
D. 273,399	4/1984	Zierhut .	
D. 273,400	4/1984	Zierhut .	
D. 273,401	4/1984	Zierhut .	
D. 284,583	7/1986	Zierhut .	
D. 284,584	7/1986	Zierhut .	
D. 284,585	7/1986	Zierhut .	
D. 284,676	7/1986	Malm .	
D. 295,537	5/1988	Davidson et al. .	
D. 306,178	2/1990	Lauper	D19/43 X
D. 312,477	11/1990	Porsche	D19/43
D. 319,844	9/1991	Grötsch et al. .	
D. 339,607	9/1993	White et al.	D19/43 X
634,013	10/1899	Mitchell .	
4,844,642	7/1989	Inaba et al. .	
4,915,529	4/1990	List .	

OTHER PUBLICATIONS

Forms PCT/IPEA/416 dated Apr. 12, 1994 and PCT/IPEA/409 from International Application No. PCT/US92/09814.

Primary Examiner—Steven A. Bratlie
Attorney, Agent, or Firm—Dilworth & Barrese

[57] ABSTRACT

A removable cap for receiving a writing implement includes a hollow tubular member with a closing wall at one end and an opening at the other end. The closing wall possesses three radial rib members and a central interior land portion which define three arcuately shaped apertures which are configured to allow air to communicate with the interior of the cap to dry residual ink on the writing point of the implement.

15 Claims, 4 Drawing Sheets

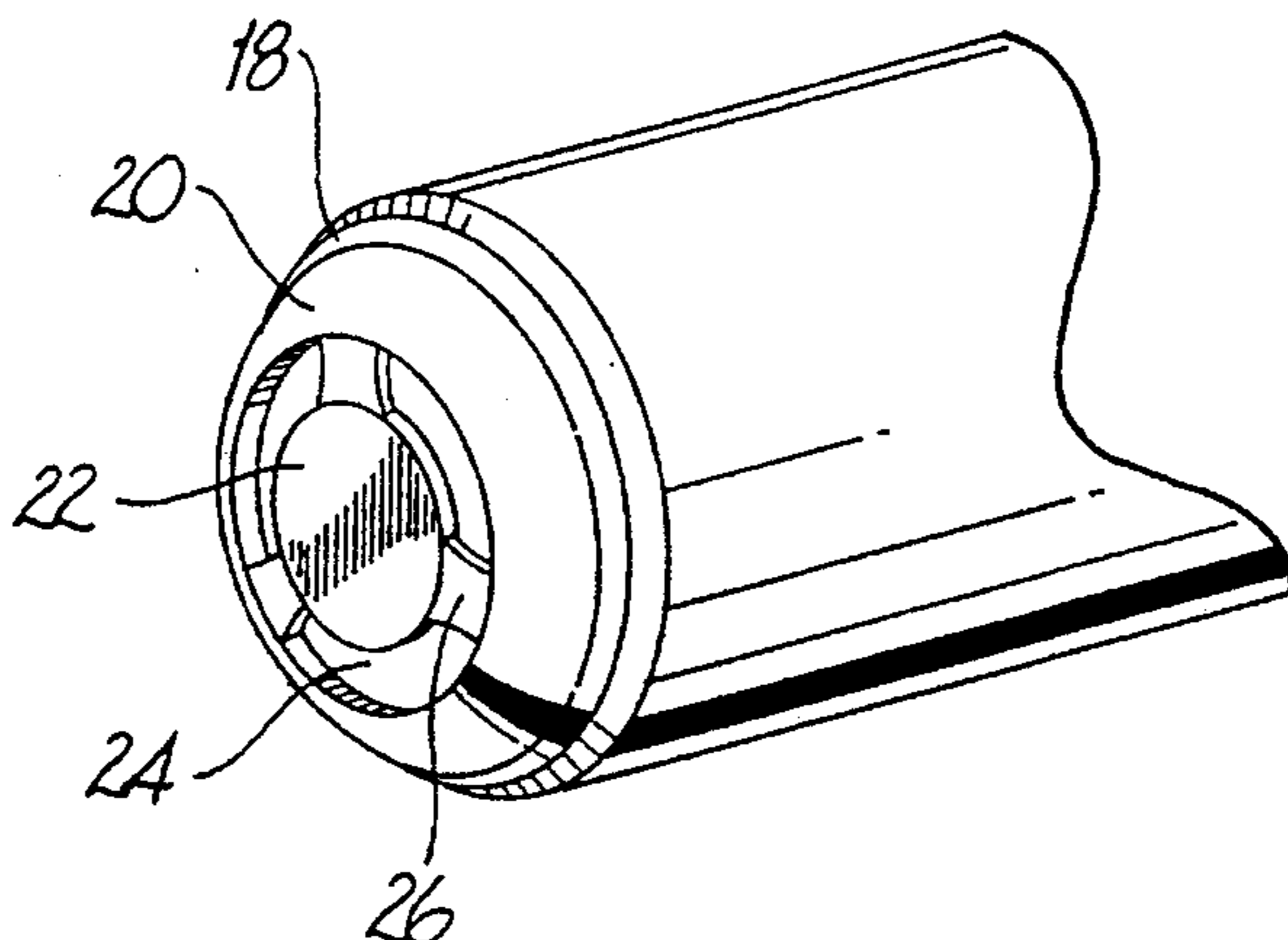

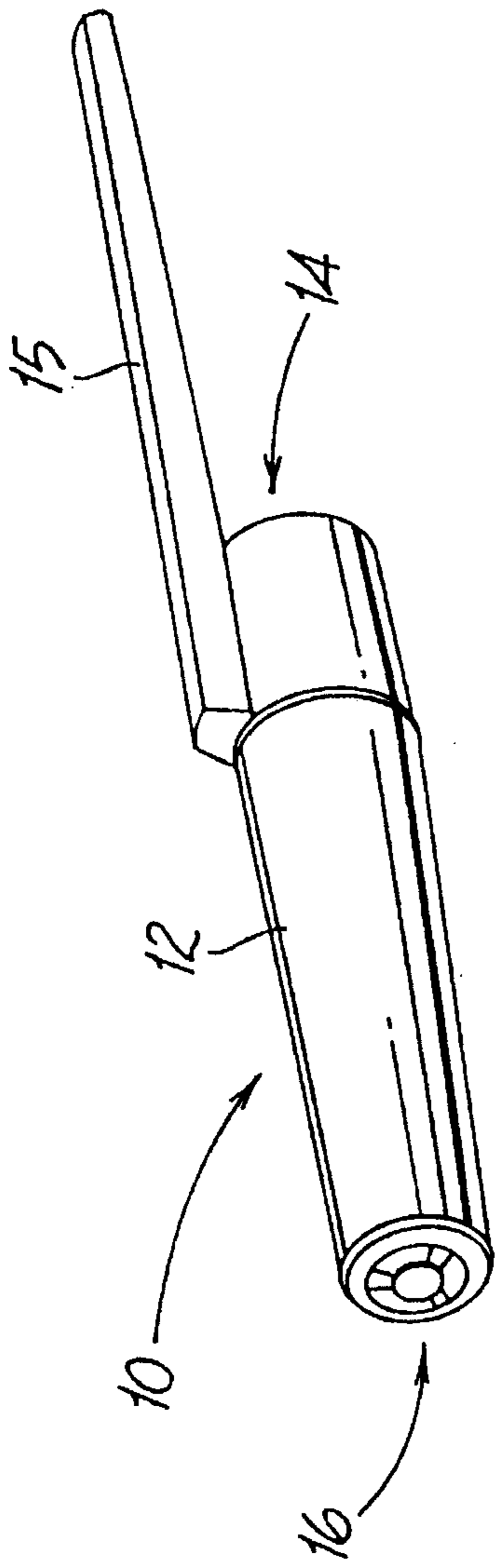

FIG. 1

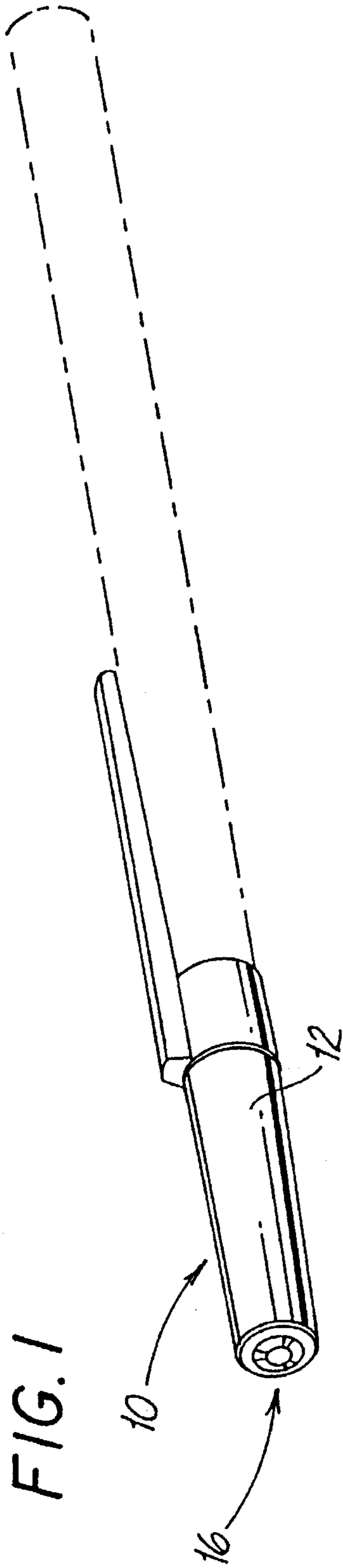

FIG. 2

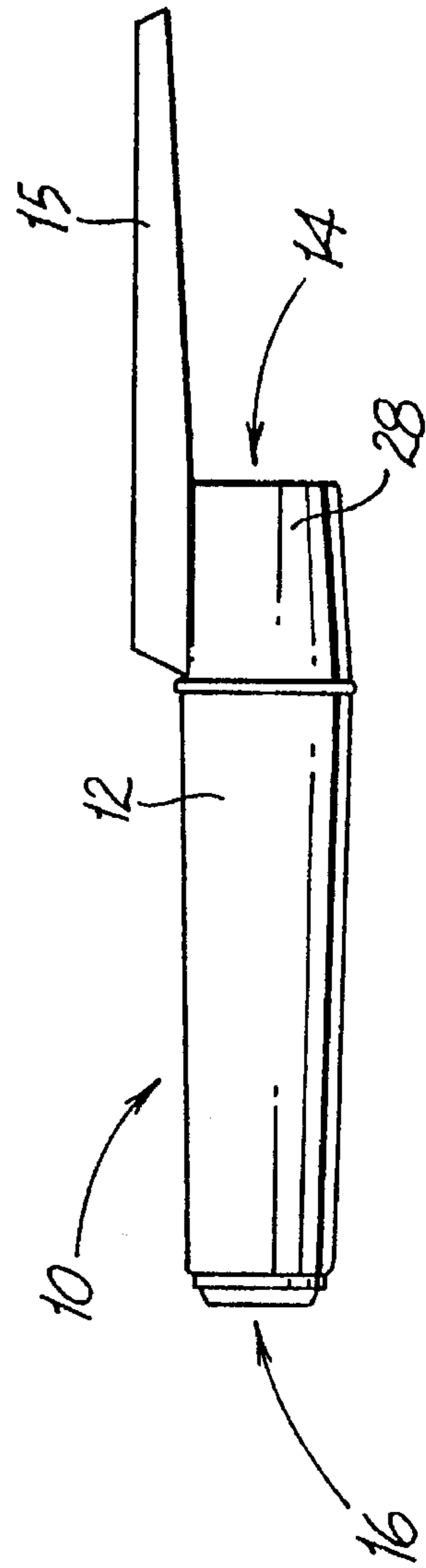
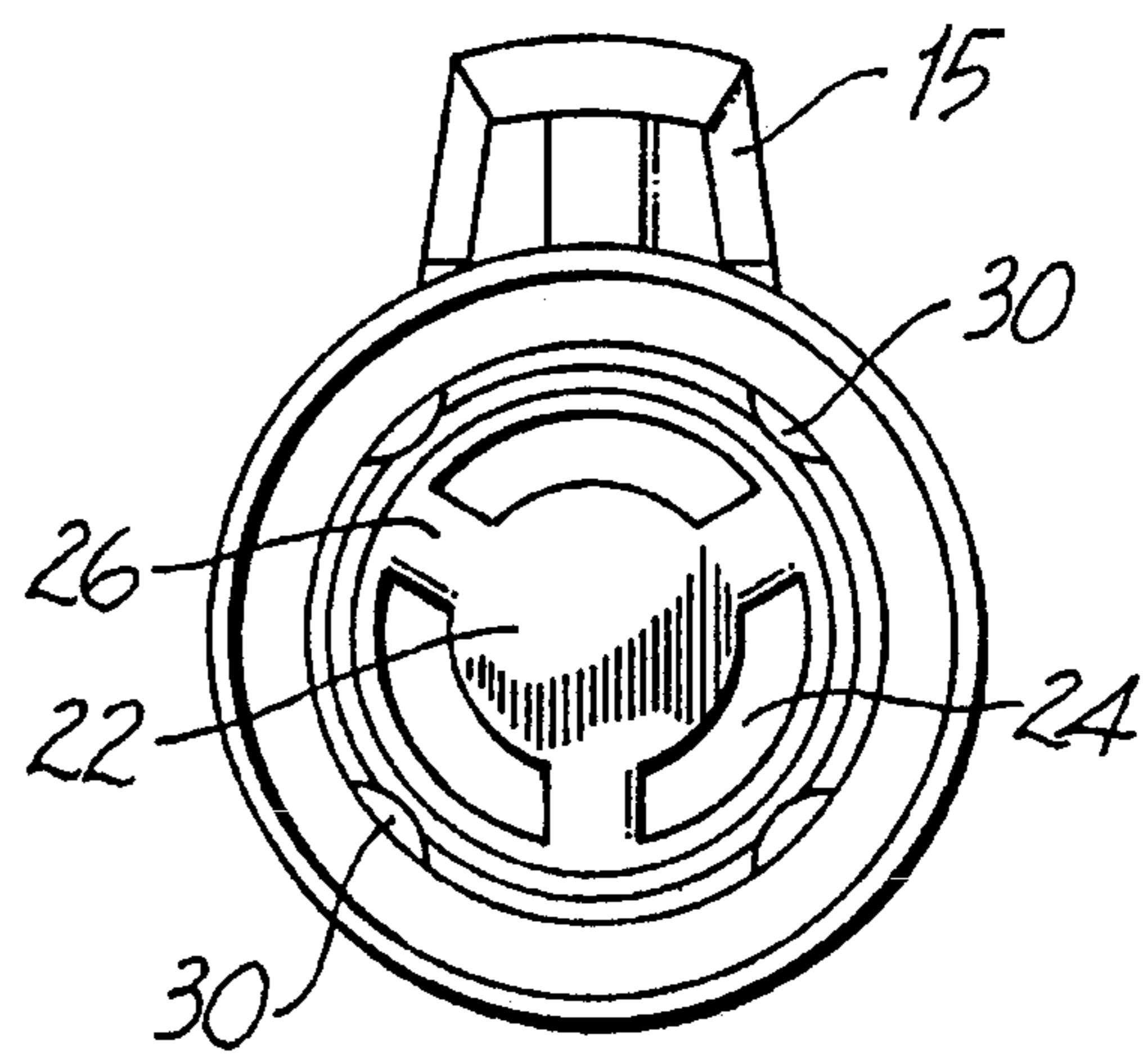
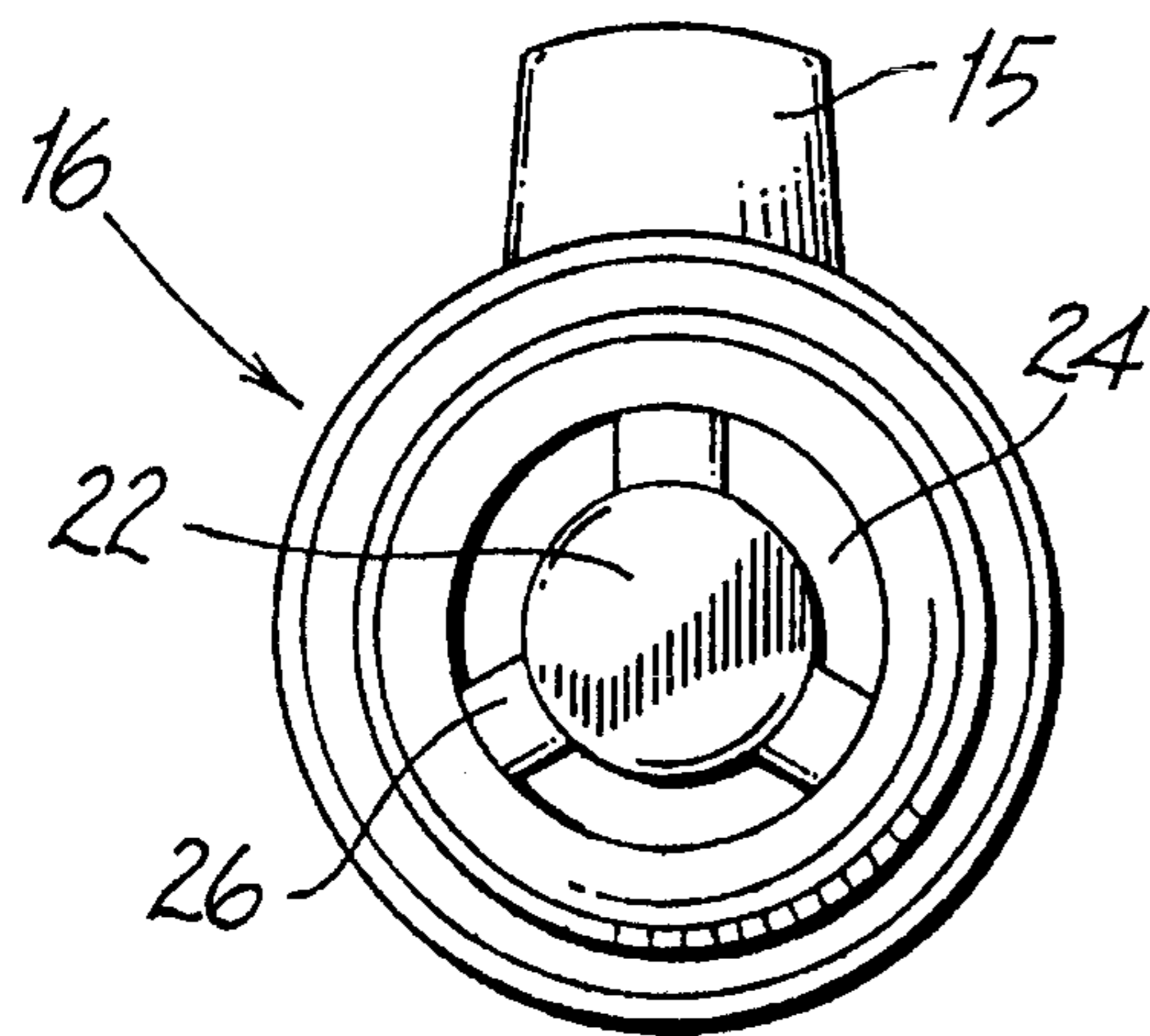
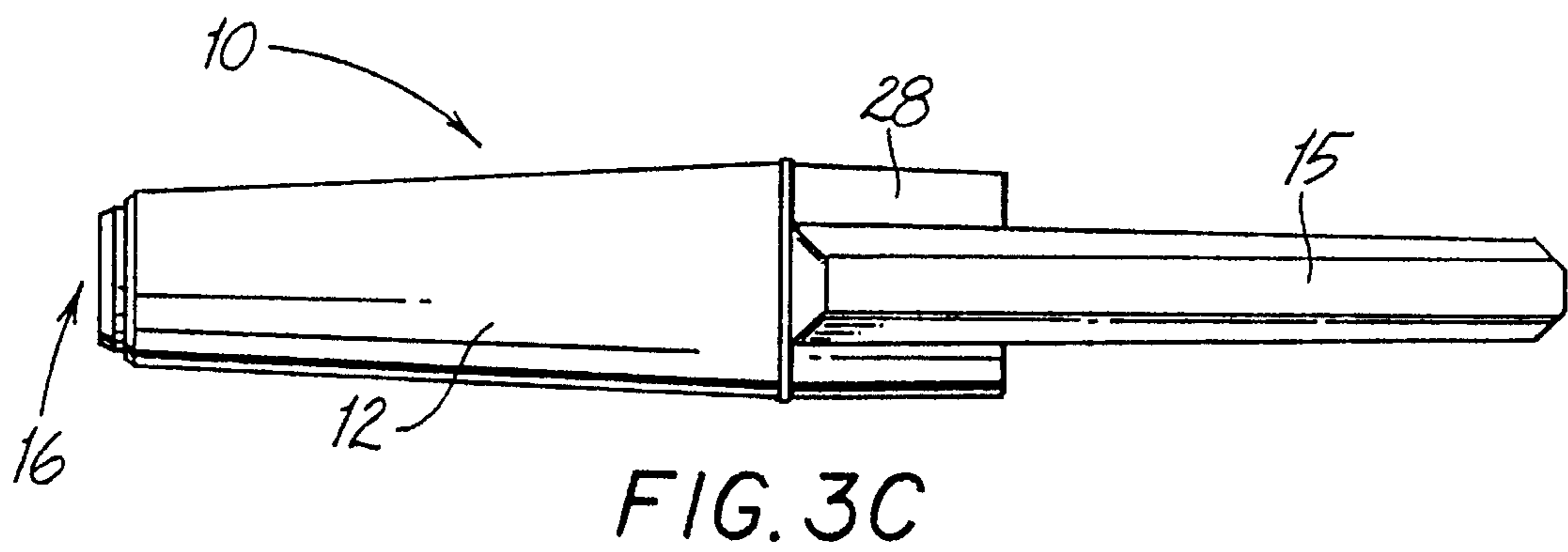
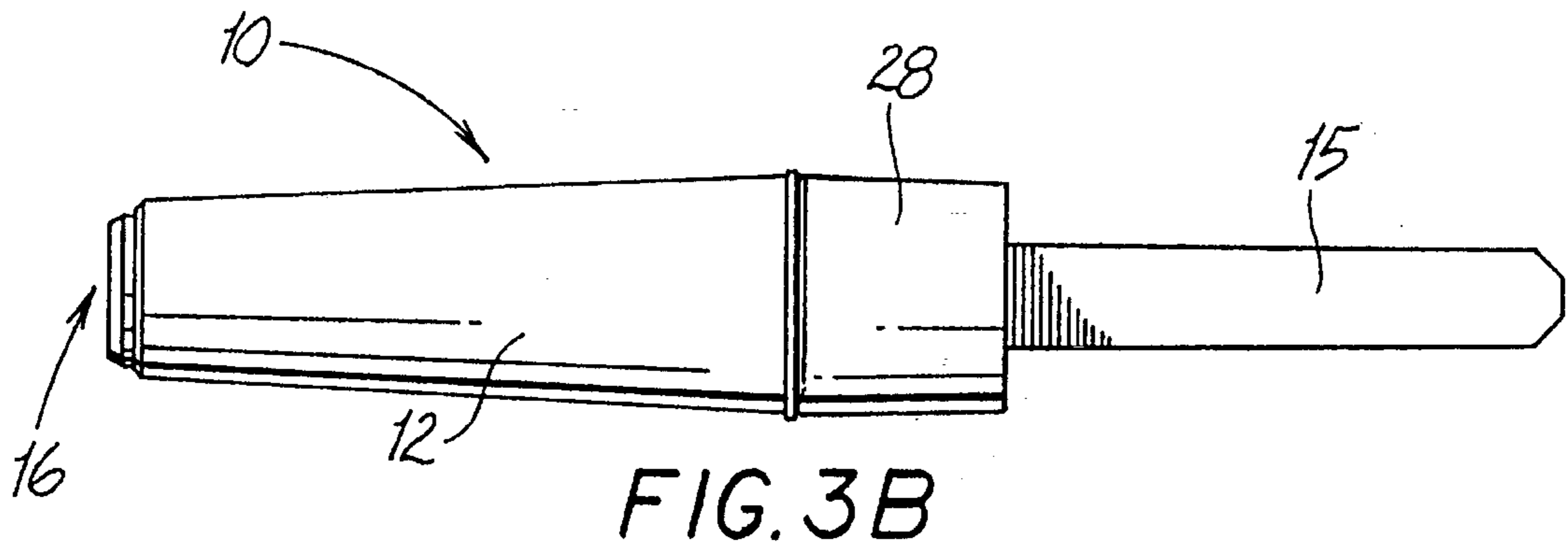

FIG. 3A



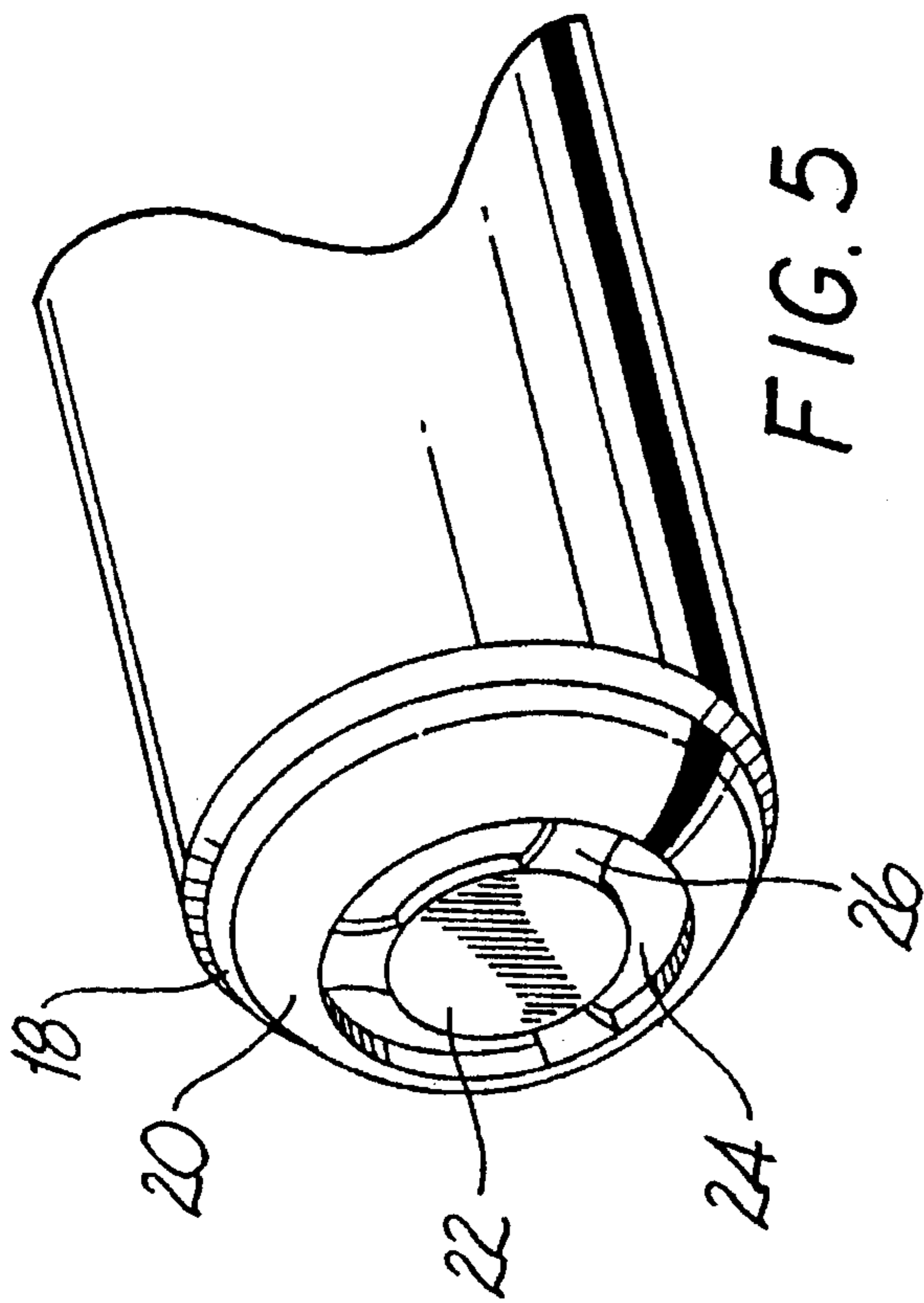

FIG. 5

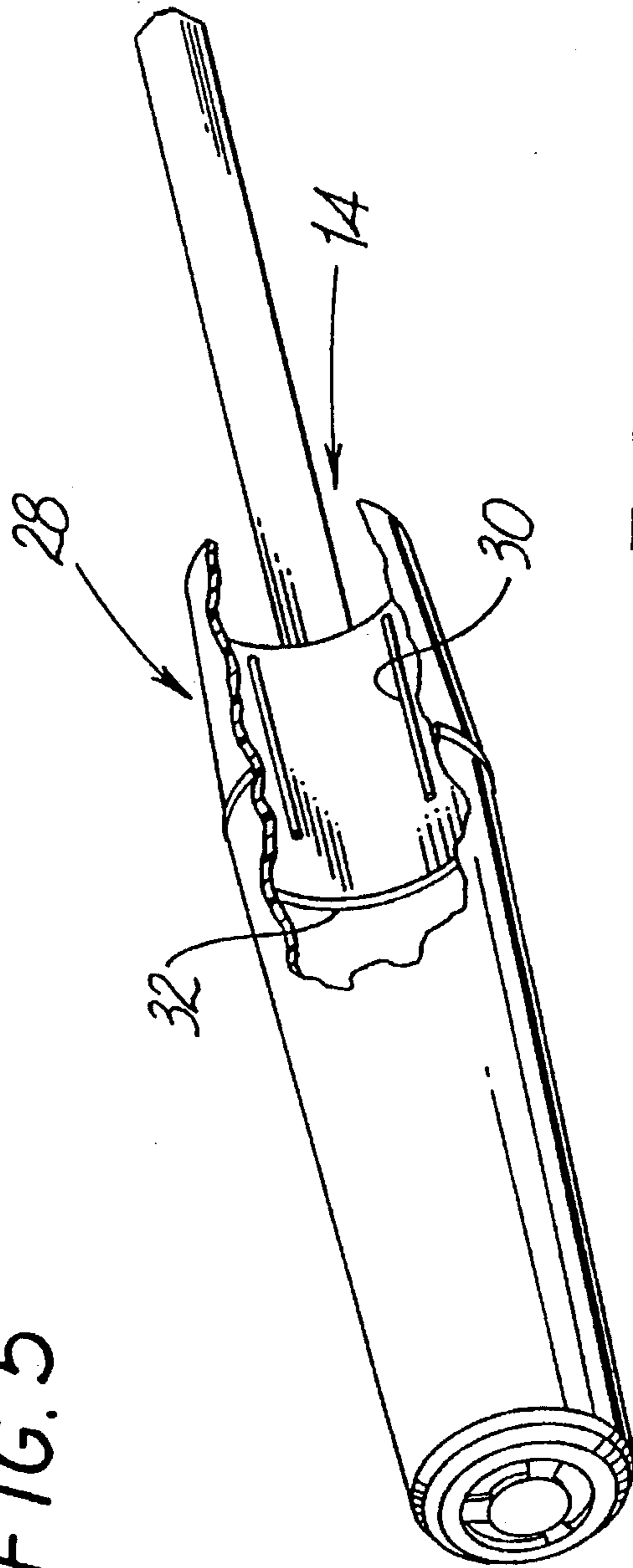
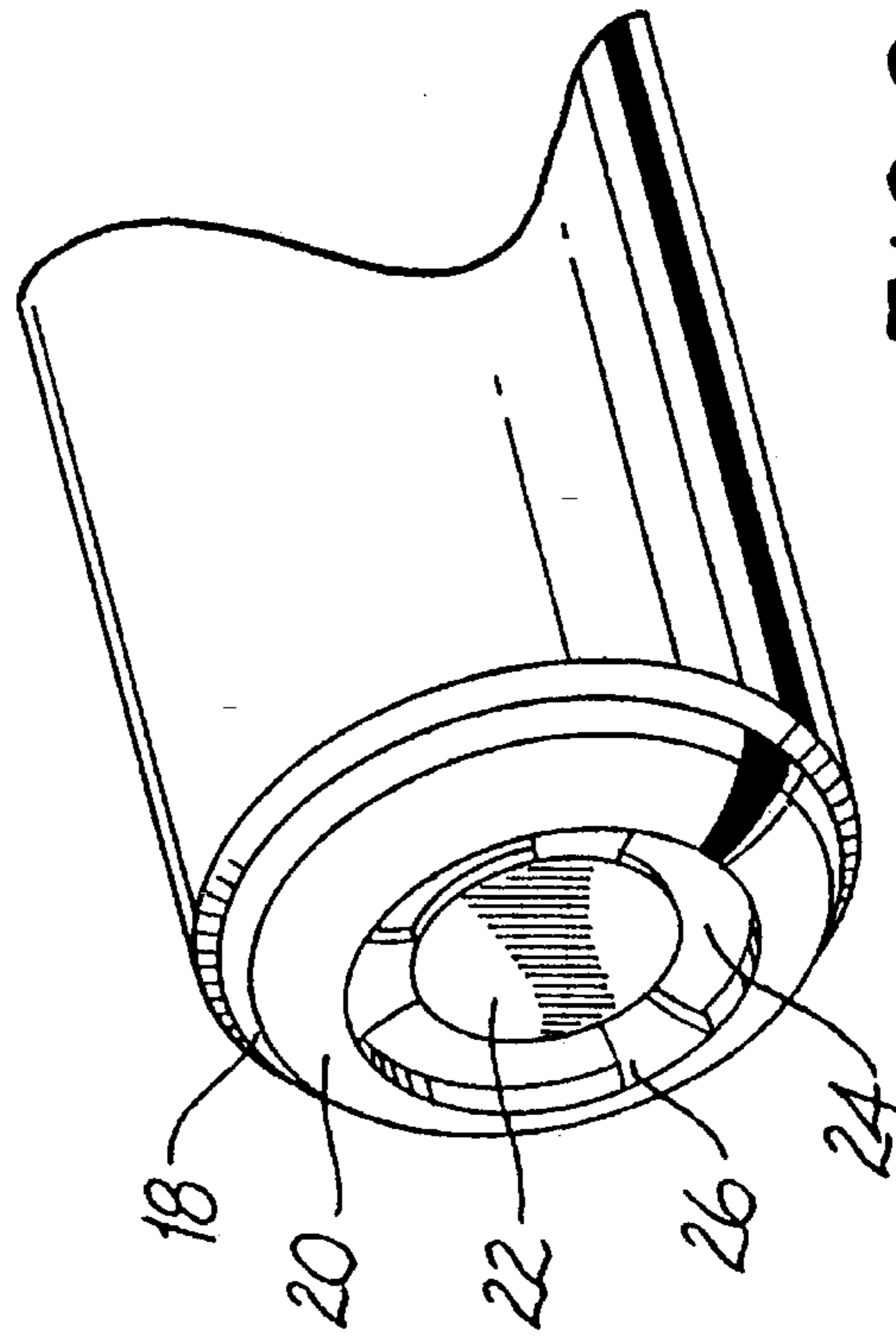
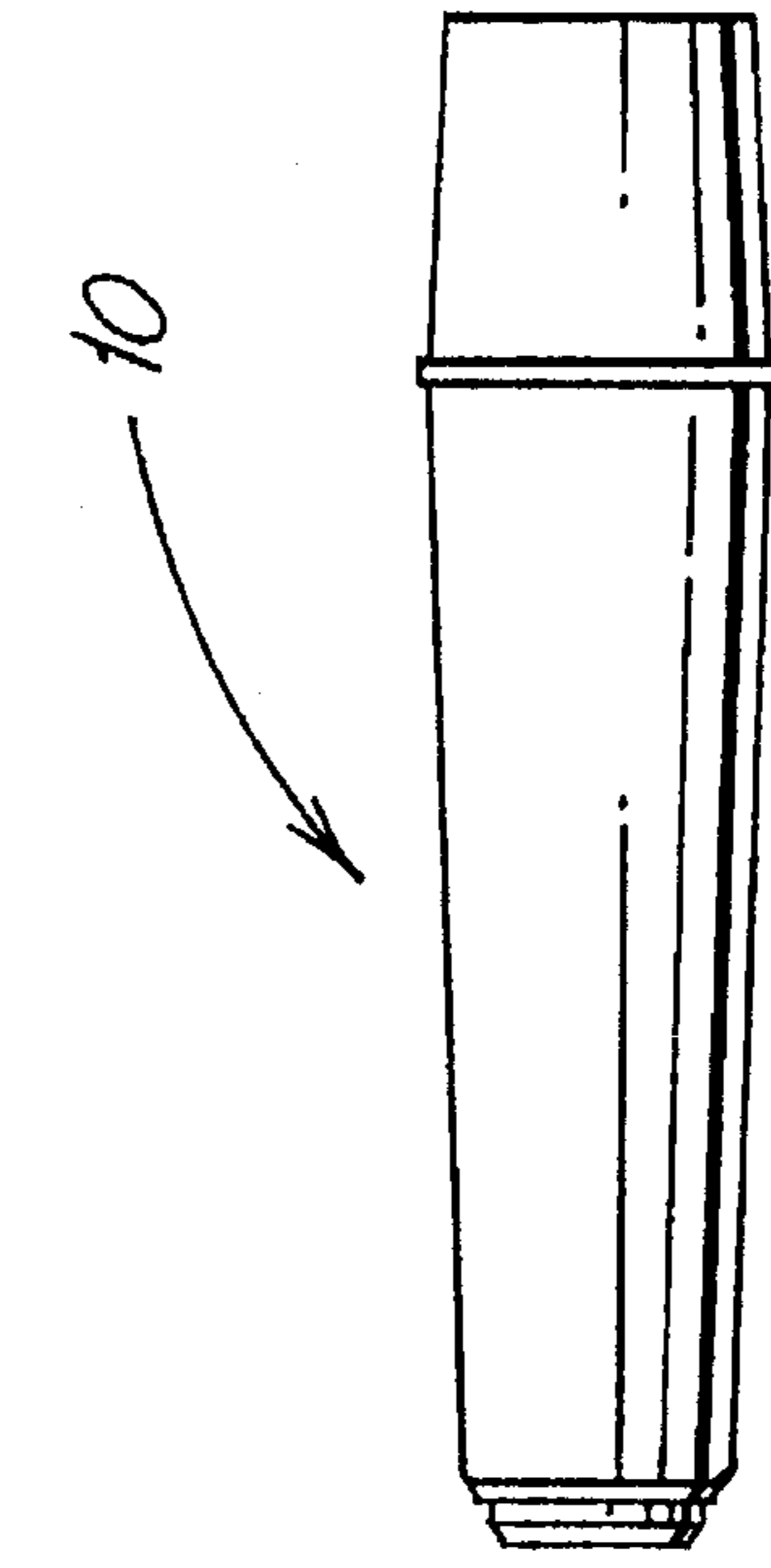
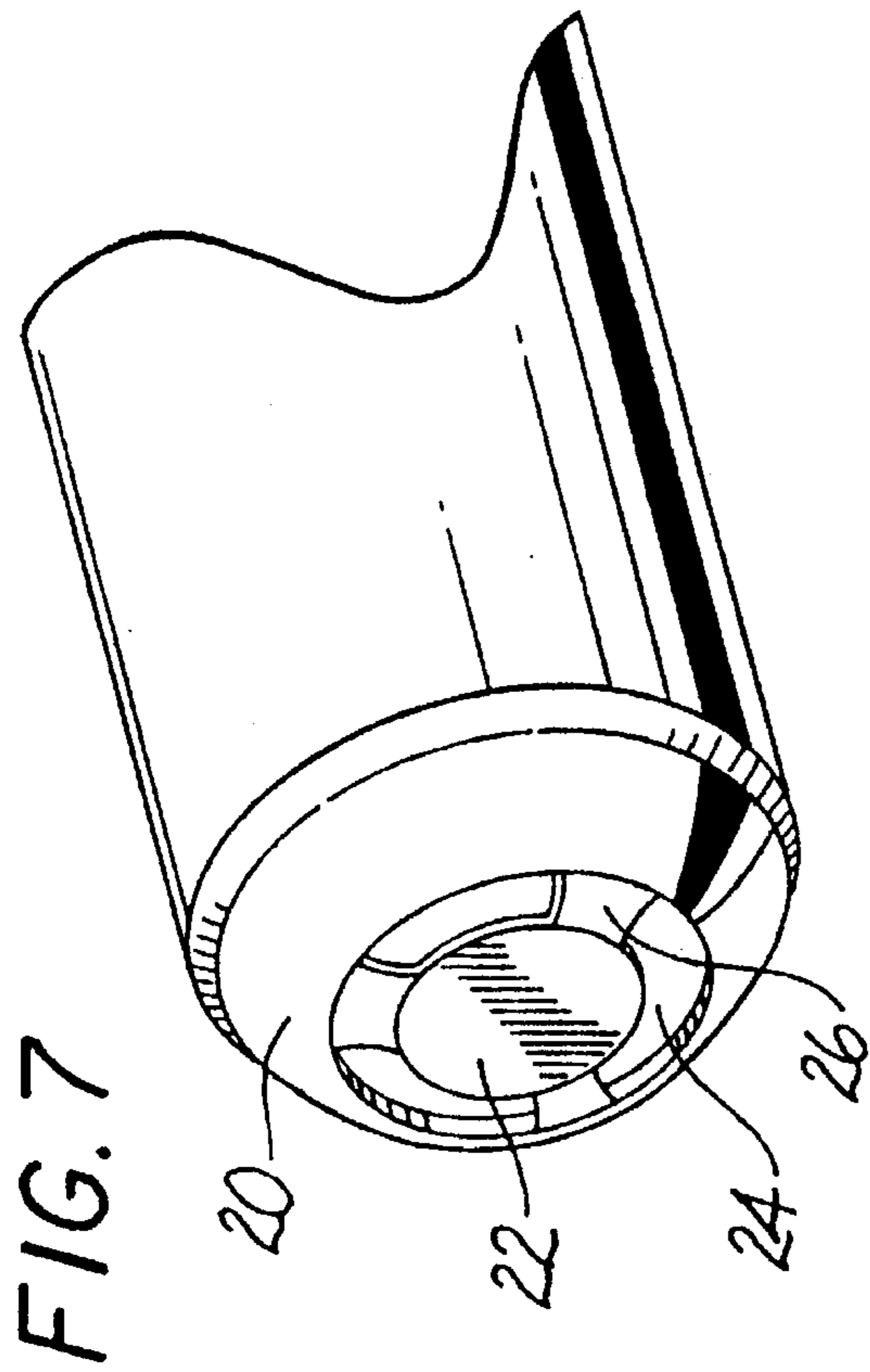
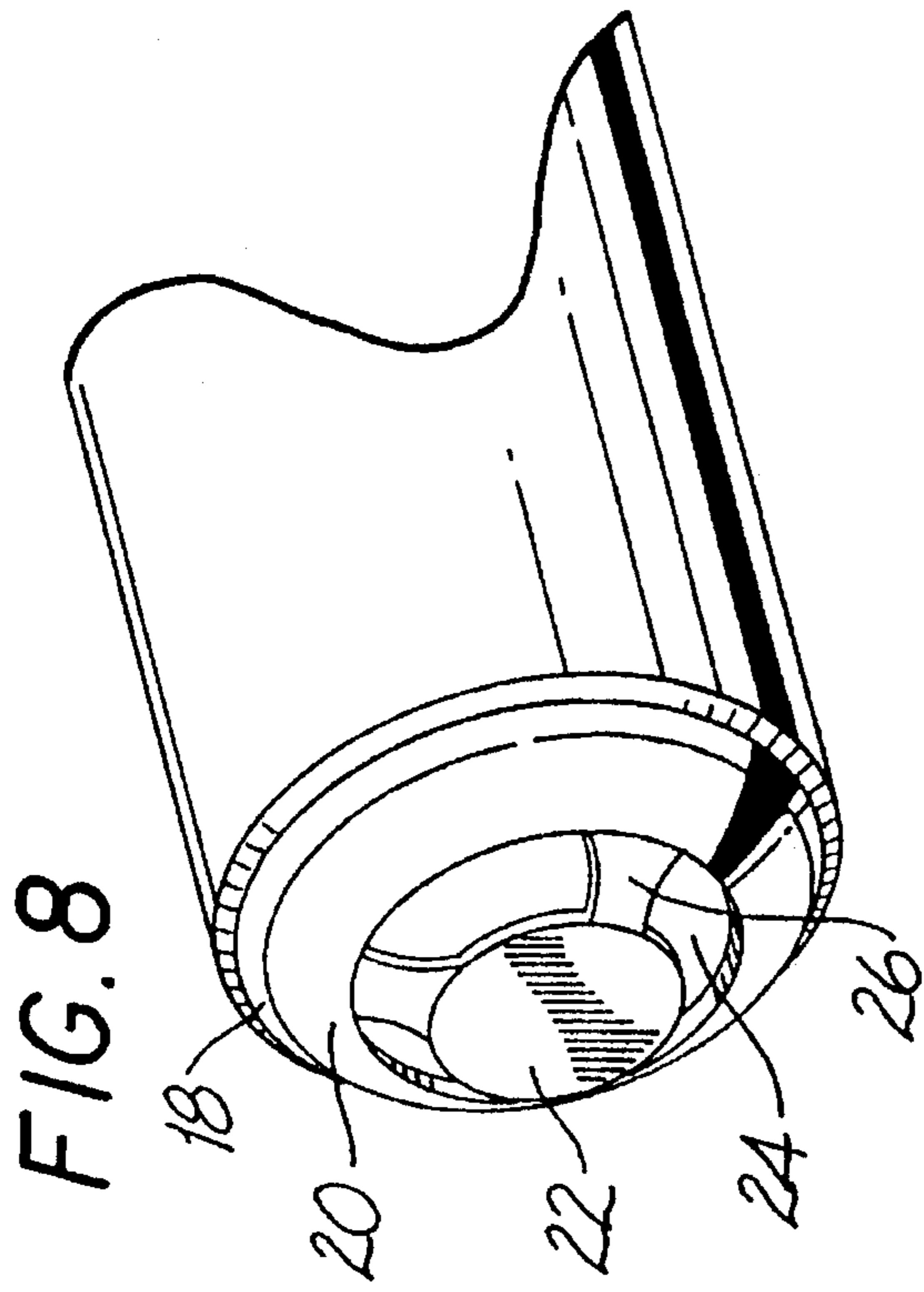

FIG. 6



CAP FOR WRITING AND MARKING INSTRUMENTS

This is a continuation of application Ser. No. 08/078,581 filed on Jun. 16, 1993, now abandoned which is a continuation of application Ser. No. 07/791,895 filed on Nov. 13, 1991, now U.S. Pat. No. 5,230,578.

BACKGROUND OF THE INVENTION

1. Field of the Invention

The present invention relates to removable protective caps for writing implements, and in particular, to a removable cap having a passageway to permit air to flow into the interior of the cap and circulate to dry residual ink at the writing point.

2. Discussion of the Prior Art

Removable caps for writing implements are typically configured to enclose the writing portion of the implement to protect the functional components therein. A conventional removable cap usually includes a hollow body member having an opening at one end to receive the implement and being closed at the other end to enclose the writing portion of the instrument within the body member.

Although known removable caps are effective in protecting the functional components of an implement, these caps present several disadvantages. Typically, the conventional removable cap effectively seals the writing point, such sealing thereby preventing the residual ink at the writing point from drying after use. Consequently, seepage of ink from the point commonly occurs. To overcome this difficulty, some known removable caps have been provided with apertures which permit air to flow through the interiors of the caps when the caps are secured on the implements. Examples of such configurations are illustrated in PCT Application WO 89/11978 and in U.S. Pat. Nos. 5,000,604 to Isoda, 5,000,603 to Isoda, and 4,915,529 to List.

PCT Application WO 89/11978 describes a cap for writing instruments having a double end wall and an air channel which perforates the front face of the implement. While there is a path for air flow, the double end wall provides a complex construction requiring close tolerances during construction to prevent obstruction of the vent openings.

Isoda ('603) and Isoda ('604) each describe a safety cap having a cylindrical outer body and a corresponding cylindrical inner cap which is attached to the outer body for sealing the tip of a pen or marker. List ('529) describes a cap body having an axial passageway which is disposed within the cap body and runs parallel to a sealing channel which covers the pen or writing instrument tip.

Although the aforementioned devices provide a passage for air to flow through the interior of the cap, these devices present a number of disadvantages. As made apparent by the foregoing descriptions, they are relatively structurally complex and rely on strategically positioned apertures and/or interconnected spaces to establish the air passageway. Furthermore, many do not provide for circulation of air about the writing tip when the cap is positioned on the writing instrument.

The present invention provides a protective removable cap for a writing implement that effectively engages and protects the writing portion of an implement, while allowing air to circulate about the point to dry residual ink at the writing point. The cap is also configured to allow for circulation of air while preventing contact of the writing point of the implement with the closed end of the cap.

SUMMARY OF THE INVENTION

A vented removable cap for receiving a writing implement is provided, where the cap comprises a hollow tubular member having an opening at a first end and a closing wall at a second end. The closing wall comprises a generally circular interior land portion and a plurality of radial rib members which define arcuately-shaped openings surrounding the land portion. The radial rib members extend from the circular land portion to an inner peripheral surface of the closing wall. The closing wall may also include an annular surface extending from the tubular member in a concentric manner, extending from the second end of the tubular member along a longitudinal axis of the tubular member. A beveled surface may also be provided, which extends from the annular surface and is also concentric with the tubular member. The circular land portion is thereby secured to the beveled surface by the radial rib members. The annular surface and the beveled surface provide additional spacing at the second end of the tubular member to accommodate the tip of the writing instrument and to facilitate circulation of air about the tip when the cap is positioned on the writing instrument.

The tubular member of the removable cap also includes a plurality of axially extending partial ribs on the inner peripheral surface thereof adjacent its proximal end. An inner circumferential rib may also be provided and disposed at a position intermediate the ends of the tubular member. The axially extending partial ribs and the circumferential rib are adapted to frictionally engage the outer peripheral surface of the writing implement to limit insertion of the writing instrument into the removable cap to maintain space at the second end of the cap to allow for air circulation.

BRIEF DESCRIPTION OF THE DRAWINGS

The foregoing features of the present invention will become more readily apparent and may be understood by referring to the following detailed description of illustrative embodiments of the vented removable cap, taken in conjunction with the accompanying drawings, in which:

FIG. 1 is a perspective view of the removable cap of the present invention;

FIG. 2 is a perspective view of the removable cap of FIG. 1 secured to a writing implement shown in phantom;

FIGS. 3A, 3B and 3C are side, rear, and front elevational plan views, respectively, of the removable cap of FIG. 1;

FIG. 4A is an axial plan view of the removable cap of FIG. 1 showing the closing wall from the closed end of the cap;

FIG. 4B is an axial plan view of the removable cap of FIG. 1 showing the closing wall from the open end of the cap;

FIG. 5 is a partial enlarged view of the closing wall of the removable cap of FIG. 1;

FIG. 6 is a perspective view of the removable cap of FIG. 1 with a partial cut away of the open end;

FIG. 7 is a partial enlarged perspective view of an alternative embodiment of the closing wall of the removable cap of FIG. 1;

FIG. 8 is a partial enlarged perspective view of a further alternative embodiment of the closing wall of the removable cap of FIG. 1;

FIG. 9 is a partial enlarged perspective view of a further alternative embodiment of the closing wall of the removable cap of FIG. 1; and

FIG. 10 is a side elevational plan view of another embodiment of the removable cap of FIG. 1 in which the cap is formed without a pocket clip.

DETAILED DESCRIPTION OF THE
PREFERRED

Referring now in specific detail to the drawings, in which like numerals identify similar or identical elements throughout the several views, FIG. 1 illustrates a protective removable cap **10** in accordance with the present invention. Removable cap **10** is configured to receive and enclose the writing portion of a writing implement, as shown in phantom in FIG. 2, to allow for the circulation of air about the tip of the writing instrument to prevent seepage of ink and subsequent blotting and clogging of the tip, when the cap is positioned on the writing instrument. The cap protects the components of the writing instrument therein and prevents the user from engaging the sharp point of the implement when not in use. Preferably, removable cap **10** is integrally formed as a single piece unit by conventional injection molding techniques. Such techniques are capable of manufacturing removable caps cost effectively and in great volume.

As shown in FIGS. 1-3, removable cap **10** comprises a tubular member **12** having an opening **14** at a first end, a longitudinally circular passageway through which the body of an implement may pass, and closing wall **16** at a second end. Tubular member **12** may taper in diameter towards closing wall **16**, such configuration corresponding to the tapering of a writing implement towards its writing point. However, tubular member **12** is not limited to this tapering configuration and may in the alternative be generally cylindrically shaped. Tubular member **12** may also include a pocket clip **15** which is integrally molded with the tubular member, or tubular member **12** may not be provided with such a clip, as shown in FIG. 10.

Referring now to FIGS. 4 and 5, closing wall **16** of the present invention is illustrated in detail. FIG. 4A illustrates an axial view of the closing wall **16** of the cap, while FIG. 5 illustrates an enlarged partial perspective view of the closing wall. Closing wall **16** is integrally formed with tubular member **12** and includes an annular surface **18** which extends from the second end of tubular member **12** in a longitudinal direction. Preferably, the diameter of annular surface **18** is uniform throughout its length and is slightly smaller than the diameter of the tubular member at its second end. A beveled surface **20** may also be provided which extends from annular surface **18** and tapers in diameter as shown. Beveled surface **20** provides closing wall **16** a dome-like appearance as best illustrated in FIG. 5. Alternatively, closing wall **16** may be formed without annular surface **18** as shown in FIG. 7, such that in this embodiment beveled surface **20** extends directly from the second end of tubular member **12**.

Referring again to FIGS. 4A and 5, closing wall **16** also includes a generally circular land portion **22** and three rib members which extend radially from circular land portion **22** and engage tubular member **12** at the inner peripheral surface of closing wall **16**, or at the inner surface of annular surface **18**. Rib members **26** form three arcuately shaped apertures **24** which form an overall circular pattern around the land portion. Apertures **24** provide a passageway wherein the interior of the removable cap is in direct communication with air on the exterior side of closing wall **16**. Thus, when the cap is positioned on the implement, air can freely flow into the interior of cap **10** and circulate about the writing point of the implement to dry residual ink and prevent undesirable blotting and clogging of the writing point. Apertures **24** are of sufficient size to provide an adequate flow of air. It is to be noted that the number of

apertures **24** and rib portions **26** is not limited to three and land portion **22** may assume any shape.

As previously mentioned and best shown in FIG. 5, annular surface **18** extends away from tubular member **12** in the longitudinal direction and beveled surface **20** similarly tapers away from annular surface **18**, the combination of each effecting a raised configuration of closing wall **16**, whereby circular land portion **22** is distally displaced relative to the second end of tubular member **12** but within the plane defined by beveled surface **20**. This displacement enables the removable cap to receive and accommodate the writing point of an implement without experiencing contact between the point and the circular land portion even in situations wherein the implement is inserted too deeply within tubular member **12** and the point of the implement protrudes past the end of tubular member **12**. Thus, damage occurring to the writing point due to contact with the land portion and closing wall is avoided.

In the embodiment of FIGS. 1-5, land portion **22** and the end of beveled surface **20** are at the same position along the longitudinal axis defined by tubular member **12**. In a further alternative embodiment, land portion **22** is further displaced from the end of beveled surface **20**, such as shown in FIG. 8. Land portion **22** may extend beyond the plane of the end of beveled surface **20** to provide additional space for the writing point of the implement. This feature is made possible by increasing the length of ribs **26** and/or adjusting the angles of the ribs relative to the longitudinal axis defined by tubular member **12**. It is also within the scope of the present invention for land portion **22** to be displaced towards the open end of tubular member **12** in relation to beveled surface **20** as shown in FIG. 9. In accordance with this embodiment, land portion **22** is disposed within the interior of closing wall **16**, but still remains disposed beyond the end of tubular member **12**.

Referring now to FIG. 6, the proximal or receiving end section **28** of tubular member **12** is illustrated in detail. Receiving section **28** is generally cylindrically-shaped and is adapted to receive a writing implement of similar configuration. Preferably, the inner diameter of end section **28** remains constant throughout the length of the end section. It is also preferable that the inner diameter at opening **14** and receiving section **28** be slightly greater than the diameter of the implement to be inserted. As will be appreciated from the following description, such dimensioning will facilitate the insertion and retention of the writing implement within removable cap **10**.

As can be seen in FIG. 6, a plurality of axially extending partial ribs **30** are provided on the inner surface of end section **28** adjacent opening **14**. Ribs **30** are spaced equidistantly along the inner peripheral surface of receiving section **28** and are slightly raised from the inner surface of the receiving section. A circumferential rib **32** is also provided and disposed between receiving section **28** and closing wall **16**. Circumferential rib **32** is slightly raised above the inner surface of tubular member **12** and possesses a diameter which is preferably substantially equal to or less than the peripheral diameter of the implement portion it will engage.

Upon insertion of an implement within removable cap **10**, the combination of partial ribs **30** and circumferential rib **32** forms a sufficient frictional engagement with the peripheral surface of the implement to effectively limit the entry of the instrument and secure the removable cap to the implement, to prevent the implement from being inserted too deeply within the cap. It is to be appreciated that the diameter of circumferential rib **32** may be smaller than the effective

diameter of partial ribs **30** to correspond to the tapering writing portion of the implement.

The protective cap of the present invention overcomes the disadvantages of the prior art by providing a simple, inexpensive one-piece protective removable cap that effectively engages a writing implement while also providing an adequate and relatively simple means to allow air to flow about the tip of the writing implement within the interior of the cap. The arcuately shaped openings provide direct axial communication with the interior of the protective cap and may be integrally formed with the cap during the injection molding process. The raised configuration of the closing wall provides sufficient clearance for the writing point of the implement to avoid undesirable contact between the point and the closing wall of the cap.

It will be understood that various modifications can be made to the embodiments of the present invention herein disclosed without departing from the spirit thereof. The above description should not be construed as limiting the invention but merely as exemplifications of preferred embodiments thereof. Those skilled in the art will envision other modifications within the scope and spirit of the present invention as defined by the claims appended hereto.

What is claimed is:

1. A removable cap for receiving a writing implement, which comprises:

a hollow tubular member defining a longitudinal axis and having first and second end portions, said first end portion defining an opening for receiving the implement, said second end portion including a frusto-conical surface in concentric arrangement with said longitudinal axis and having an outer end which is distal most from said first end portion;

an interior land portion displaced with respect to said longitudinal axis at a position beyond said second end of said tubular member, said land portion having a generally planar outer surface; said land portion and said outer end of said frusto-conical surface being at substantially the same position with respect to said longitudinal axis; and

three connecting portions extending from said land portion to said second end portion of said tubular member, said connecting portions defining three openings extending circumferentially about said land portion to permit air to flow between an exterior side of said land portion and an interior portion of said hollow tubular member said connecting portions being dimensioned such that the combined area of said openings is at least twice the combined upper surface area of said connecting portions.

2. A removable cap for receiving a writing implement, which comprises:

a hollow tubular member defining a longitudinal axis and having first and second end portions, said first end portion defining an opening for receiving the implement, said second end portion including a frusto-conical surface in concentric arrangement with said longitudinal axis and having a outer end which is distal most from said first end portion;

an interior land portion having a planar outer surface wherein said outer end of said frusto-conical surface said outer end is disposed with respect to said longitudinal axis at a position beyond said land portion; and

three connecting portions extending from said land portion to said second end portion of said tubular member, said connecting portions defining three openings

extending circumferentially about said land portion, the combined area of said openings being at least twice the combined upper surface area of said connecting portions whereby air is permitted to flow between an exterior side of said land portion and an interior portion of said hollow tubular member.

3. A monolithically formed removable cap for a writing implement, which comprises a tubular member defining a longitudinal axis and having a first end portion defining an opening for receiving at least a writing portion of the writing implement and a second end portion including a frusto-conical surface portion, a land portion adjacent said second end portion, said land portion having a generally planar outer surface and being in general alignment with said longitudinal axis, and three connecting portions extending radially outwardly from said land portion to said second end portion of said tubular member, said connecting portions each having at least one outer substantially planar surface portion oriented at an acute angle relative to said longitudinal axis, said connecting portions defining three apertures extending circumferentially about said land portion, the combined cross-sectional area of said apertures being at least twice the corresponding combined cross-sectional area of said connecting portions whereby air is permitted to flow between an exterior side of said land portion and an interior portion of said tubular member.

4. The removable cap according to claim 3 wherein said frusto-conical surface portion has an uppermost portion.

5. The removable cap according to claim 4 wherein said land portion is positioned below said uppermost portion of said frusto-conical surface portion.

6. The removable cap according to claim 4 wherein said land portion is positioned above said uppermost portion of said frusto-conical surface portion.

7. The removable cap according to claim 4 wherein said land portion and said uppermost portion of said frusto-conical surface portion are at substantially the same position along said longitudinal axis.

8. The removable cap according to claim 3 wherein said tubular member includes at least two axially extending rib portions disposed on an inner peripheral surface of said tubular member adjacent said first end portion thereof, said axially extending rib portions dimensioned and positioned to frictionally engage a peripheral surface portion of the writing implement received within said tubular member to facilitate retention of the writing implement therein.

9. The removable cap according to claim 3 wherein said tubular member includes an inner circumferential rib portion disposed at a position intermediate said first and second end portions, said inner circumferential rib portion dimensioned and configured to frictionally engage a peripheral surface portion of the writing implement received within said tubular member to facilitate retention of the writing implement therein.

10. A monolithically formed removable cap for a writing implement, which comprises:

a tubular member defining a longitudinal axis, said tubular member including a main body portion and a frusto-conical surface portion disposed at one end of said main body portion, the other end of said main body portion having an opening for reception of a writing implement;

a land portion in general alignment with said longitudinal axis and having a generally planar upper surface disposed beyond said one end of said main body portion; and

three connecting members connecting said land portion and said tubular member, said connecting members

each having at least one outer substantially planar portion oriented at an acute angle relative to said longitudinal axis, said connecting members being dimensioned to define three openings extending circumferentially about said land portion, the combined area of said openings being at least twice the combined cross-sectional area of said connecting members whereby air is permitted to flow between an exterior side of said land portion and an interior portion of said tubular member.

11. The removable cap according to claim 10 wherein said frusto-conical surface portion has an uppermost portion.

12. The removable cap according to claim 11 wherein said upper surface of said land portion is positioned below said uppermost portion of said frusto-conical surface portion.

13. The removable cap according to claim 11 wherein said upper surface of said land portion is positioned above said uppermost portion of said frusto-conical surface portion.

14. The removable cap according to claim 11 wherein said upper surface of said land portion and said uppermost portion of said frusto-conical surface portion are at substantially the same position along said longitudinal axis.

15. A removable cap for receiving a writing implement, which comprises a hollow tubular member defining a lon-

gitudinal axis and having a first end portion defining an opening for receiving the writing implement and a second end portion including an annular member formed monolithically with said hollow tubular member, said annular member having at least one frusto-conical outer surface portion and a generally cylindrical outer surface portion adjacent thereto, a land portion having a generally planar outer surface and being in general alignment with said longitudinal axis, and three connecting members extending outwardly from said land portion to said second end portion, said connecting members having at least one upper substantially planar surface portion oriented at an acute angle relative to said longitudinal axis and defining a plurality of arcuately-shaped apertures surrounding said land portion, the combined area of said arcuately shaped apertures being at least twice the combined area of said upper substantially planar surface portions of said connecting members whereby air is permitted to flow between an exterior side of said land portion and an interior portion of said hollow tubular member.

* * * * *