



US005343648A

# United States Patent [19] Bracken

[11] Patent Number: **5,343,648**  
[45] Date of Patent: **Sep. 6, 1994**

[54] **GARMENT INDICIA STRIP**  
[75] Inventor: **Frank D. Bracken, Dallas, Tex.**  
[73] Assignee: **Haggar Apparel Company, Dallas, Tex.**  
[21] Appl. No.: **643,769**  
[22] Filed: **Jan. 18, 1991**

### Related U.S. Application Data

[63] Continuation of Ser. No. 522,220, May 11, 1990, abandoned, which is a continuation of Ser. No. 409,765, Sep. 20, 1989, abandoned, which is a continuation of Ser. No. 223,438, Jul. 22, 1988, abandoned.  
[51] Int. Cl.<sup>5</sup> ..... **G09F 3/10**  
[52] U.S. Cl. .... **40/638; 40/299; 283/70**  
[58] Field of Search ..... **40/299, 630, 638; 283/70, 81**

[56] **References Cited**  
**U.S. PATENT DOCUMENTS**  
2,739,399 3/1956 Henson ..... 40/299  
3,350,799 11/1967 Japs ..... 40/299  
*Primary Examiner*—Brian K. Green  
*Attorney, Agent, or Firm*—Richards, Medlock & Andrews

[57] **ABSTRACT**  
A garment indicia strip and method for size labeling a pair of folded pants. A strip of flexible material has indicia repeatedly printed along a first major surface thereof. The indicia are printed using symbols having a height no greater than the width of an edge of said folded pants. A second major surface of said strip has a pressure sensitive adhesive material bonded thereto. In use, the second surface of the strip is affixed to a pair of pants at a predetermined position whereby sizing information of said pants can be determined by reading said strip when said pants are folded.

5 Claims, 1 Drawing Sheet

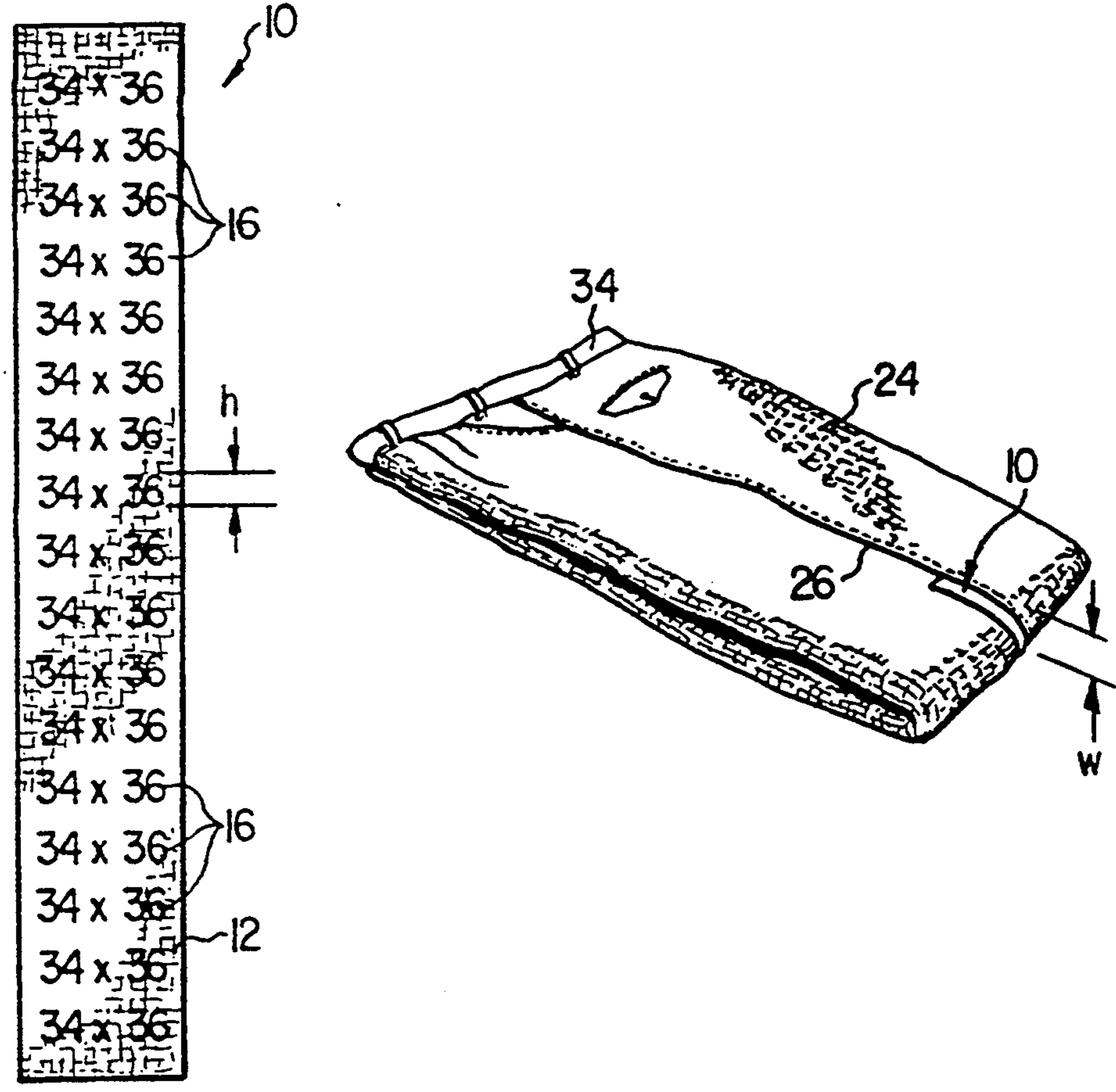

FIG. 1

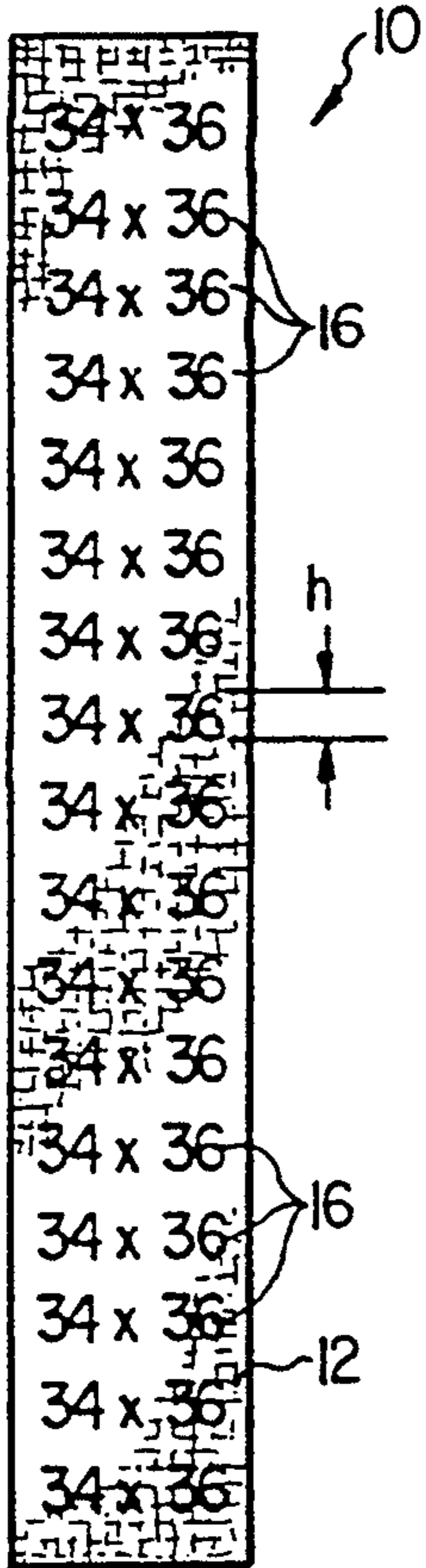

FIG. 2

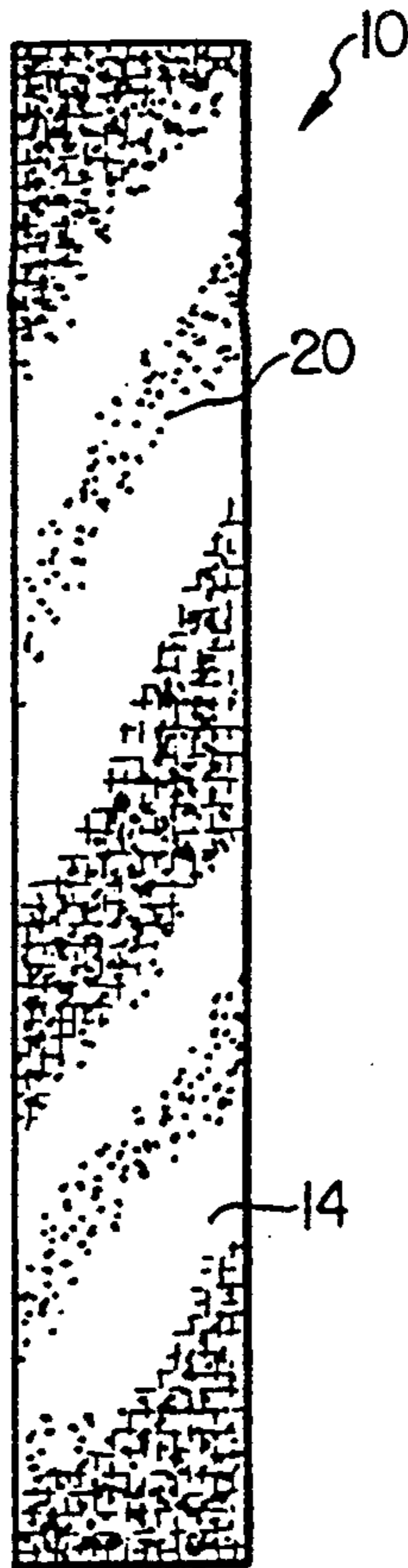

FIG. 3

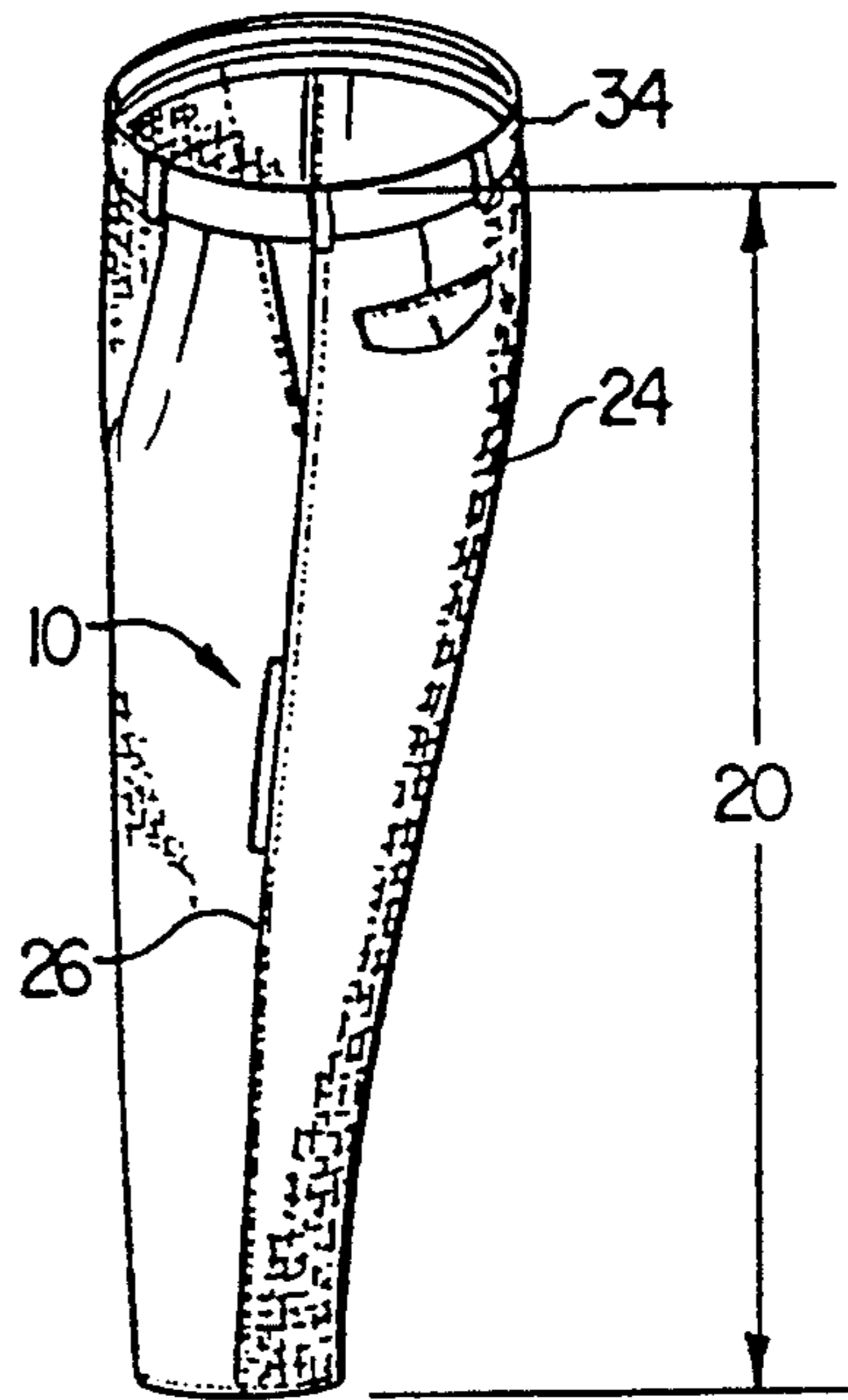

FIG. 4

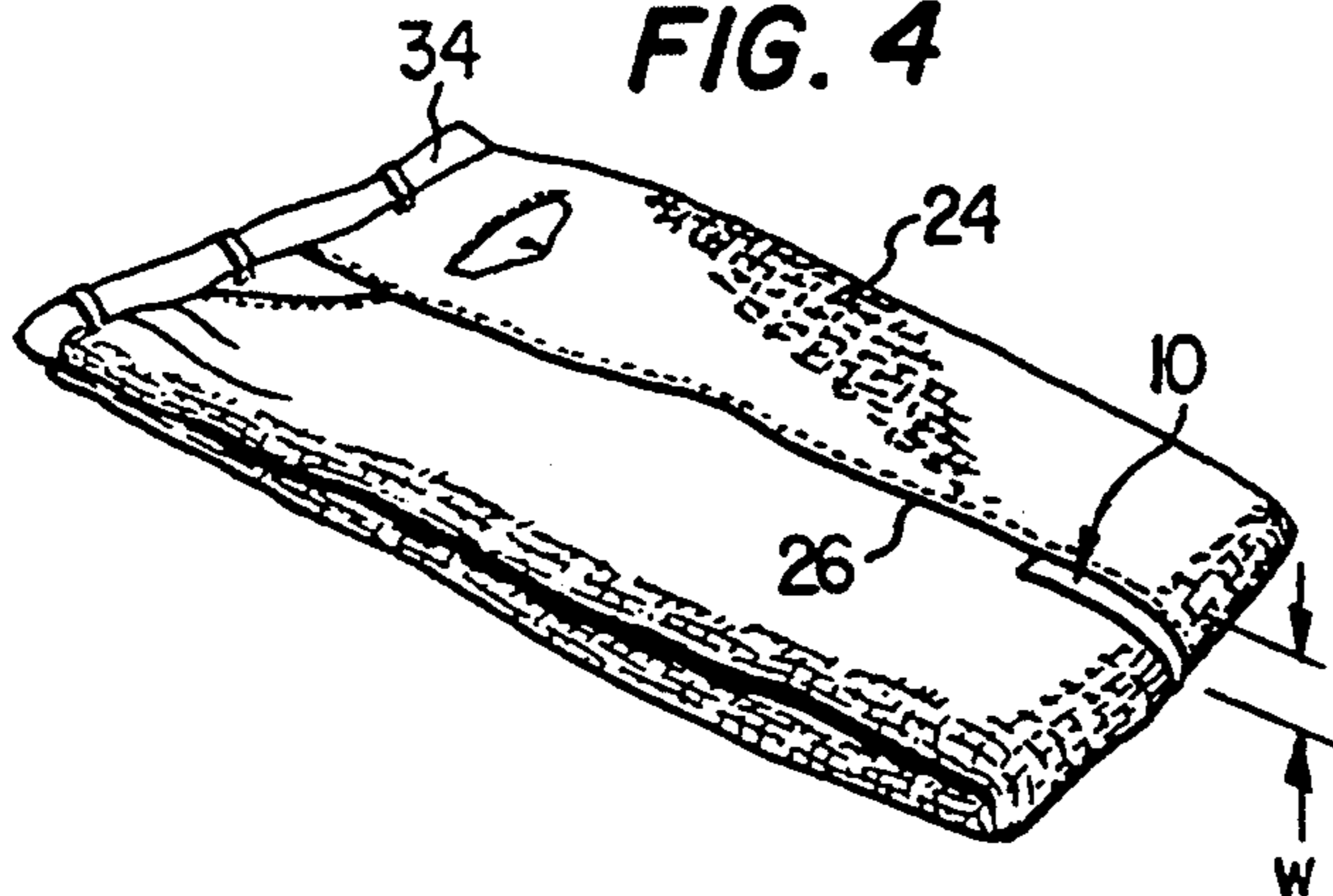
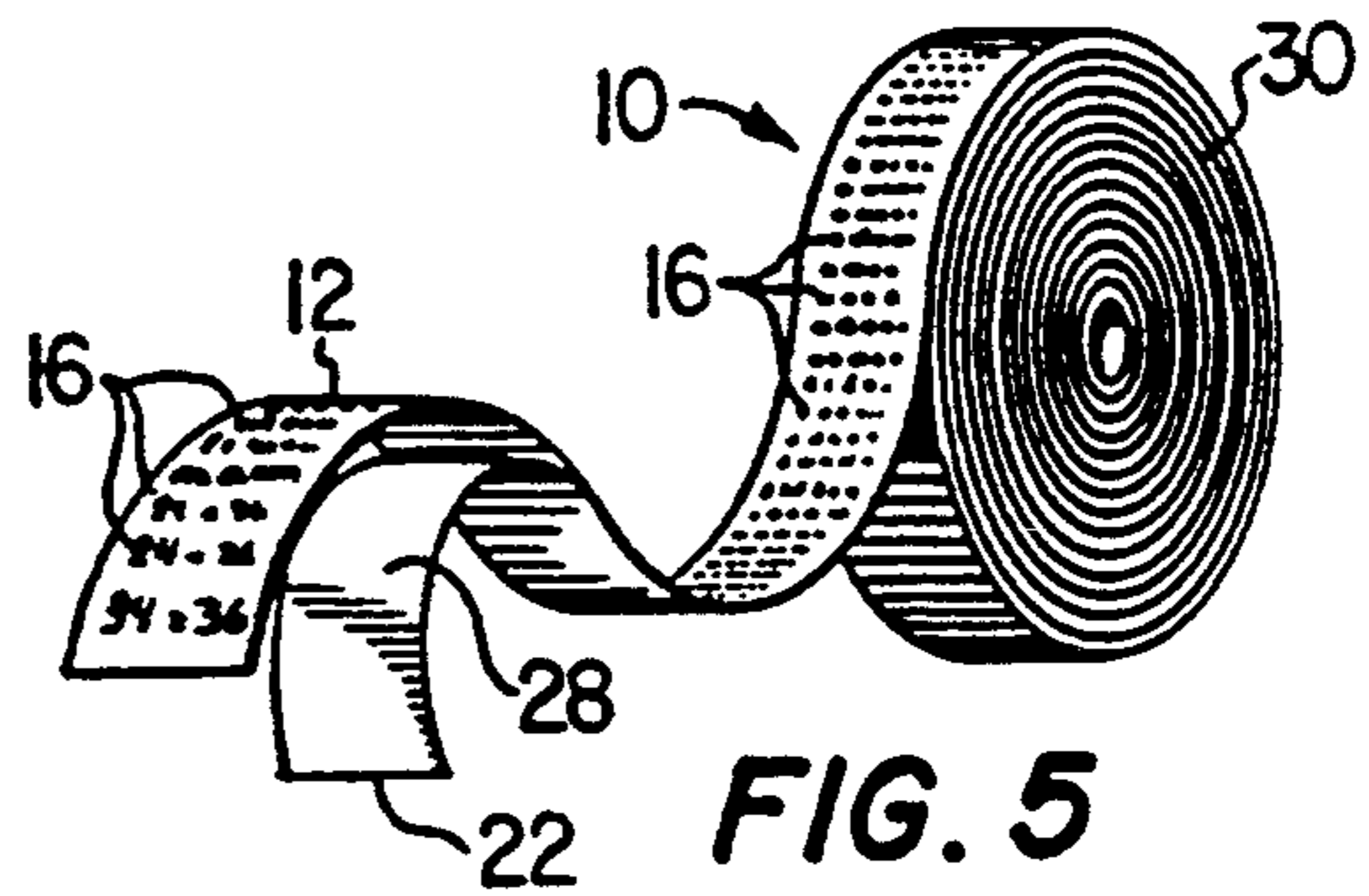

FIG. 5





## GARMENT INDICIA STRIP

This is a continuation of application Ser. No. 522,220 filed May 11, 1990, now abandoned, which is a continuation of application Ser. No. 409,765 filed Sep. 20, 1989, now abandoned, which is a continuation of application Ser. No. 223,438 filed Jul. 22, 1988, now abandoned.

### TECHNICAL FIELD

This invention relates to garment indicia in the nature of tags, labels, or the like for identification of garment information and a method for using such indicia on folded garments.

### BACKGROUND ART

Labels and hangtags are well known for the general purpose of identifying various features of garments. However, such labels and hangtags are commonly affixed to the garment in such a manner and location that the information appearing thereon, and even the label or hangtag itself, is usually hidden when the garments are folded and stacked for storage or display.

Prior inventions have attempted to overcome the shortcomings of commonly used labels and hangtags. For example, U.S. Pat. No. 2,739,339, to Henson, issued Mar. 27, 1956 shows a marking device having a stub portion which may be sewn to a seam of a garment and a tab integral with and extending substantially perpendicularly from the stub portion so as to extend beyond an edge or fold of the garment. Such marking devices have also proven to be unsatisfactory. It is desirable to have a garment indicia strip which will permit a manufacturer or retailer to fold the garment in a plurality of ways for storage or display while maintaining the visibility and legibility of the garment indicia strip. The garment indicia strip should also be flush to the surface of the garment in order to avoid inadvertent tearing or removal of the strip from the garment.

### SUMMARY OF THE INVENTION

The garment indicia strip of the present invention is suitable for use with any type of garment or article which may be folded and stacked for storage or display.

The indicia strip of the present invention has a front surface upon which garment indicia are repeatedly printed. A pressure sensitive adhesive is mounted to the rear surface of said strip such that the strip may be removably adhered to a garment.

In use, the garment indicia strip of the present invention can be placed at any point on a garment at which the garment will be folded during storage or display thereof. For example, when the garment indicia strip is used with a pair of pants, the garment indicia strip is preferably placed adjacent and substantially parallel to the side seam of the pant leg.

The garment indicia strip can be placed at any point along the side seam at which the garment will be folded. For example, if the pants are to be folded in half for storage or display, the garment indicia strip can be placed at approximately the midpoint of the side seam. If, however, the pants are to be folded in thirds for storage or display, the garment indicia strip can be placed approximately one-third the length of the side seam from the waistband of said pants.

A release liner is affixed to the indicia strips prior to their application to a garment. The release liner prevents the indicia strips from becoming inadvertently

affixed prior to their use, and more importantly, the liner allows the indicia strips and release liner to be formed into a continuous length which can be readily rolled for storage and unrolled for use.

### BRIEF DESCRIPTION OF THE DRAWINGS

For a more complete understanding of the present invention and for further advantages thereof, reference is now made to the following Description of the Preferred Embodiment taken in conjunction with the accompanying Drawings, in which:

FIG. 1 is a perspective view of the front surface of the indicia strip of the present invention;

FIG. 2 is a perspective view of the rear surface of the indicia strip of the present invention;

FIG. 3 is a perspective view of the garment indicia strip of the present invention in place on an unfolded pair of pants;

FIG. 4 is a perspective view of the garment indicia strip of the present invention on a folded pair of pants; and

FIG. 5 is a perspective, partially exploded view of indicia strips of the present invention in place on a continuous roll of released liner.

### DESCRIPTION OF THE PREFERRED EMBODIMENTS

Referring to FIGS. 1 and 2, a garment indicia strip of the present invention is generally identified by reference numeral 10. Strip 10 has a front surface 12 and a rear surface 14. Indicia 16 are printed on front surface 12 of strip 10. It has been found to be beneficial to repeatedly print indicia 16 along front surface 12. It is also beneficial that indicia 16 be printed with letters or numerals having a height "h" which is not greater than the width "w" of a folded edge of pants 24, as been seen in FIG. 4. As a result of repeatedly printing indicia 16 along strip 10 and limiting height "h" of indicia 16, indicia 16 are visible and legible whenever strip 10 is folded along its length 18, as depicted best in FIG. 4.

Rear surface 14 of strip 10 has a pressure sensitive adhesive mounted thereon. Any known pressure sensitive adhesive may be used in conjunction with the present invention. However, it has been found to be desirable to use a pressure sensitive adhesive which will not mar the surface structure of and which may be readily removed from the garment or article to which the garment indicia strip is attached. Prior to application of strip 10 to a garment, a release liner 22 is applied to rear surface 14 in order to prevent adhesive 20 from binding to any surface prematurely. Release liner 22 may be constructed of any known material such as, by way of example, but not by way of limitation, Fasson® CRACK 'N PEEL plus™. In a preferred embodiment, release liner 22 is constructed of a silicon-coated paper material.

In a preferred method for using the garment indicia strip of the present invention, a plurality of strips 10 are attached to a continuous length 28 of release liner 22, as best seen in FIG. 5. Continuous length 28 having strips 10 mounted thereon can be rolled to form roll 30 of strips 10 and release liner 22. Roll 30 facilitates compact and safe storage of strips 10 while also facilitating the dispensing of said strips for use. In a second preferred method, a plurality of strips 10 are attached to form a continuous length of said strips. The continuous length of strips 10 is then releasably adhered to continuous length 28 of release liner. In a second preferred method,



a means of detaching strips 10 from one another, such as by perforation, is provided. Strips 10 are individually removed from continuous length 28 of release liner immediately prior to application of strip 10 to the garment as described below.

Although the garment indicia strip of the present invention can be used with any garment or object, the following description of use of the garment indicia strip on a pair of pants will be deemed to describe its use on any other garment or object. Referring to FIGS. 3 and 4, the garment indicia strip 10 of the present invention can be applied to a pair of pants 24 to indicate various features of pants 24. For example, indicia 16 may reflect the waist size and/or inseam length of the pants. Indicia 16 may also indicate style number, size, color, etc. Strip 10 is preferably applied to pants 24 adjacent and substantially parallel to side seam 26 of pants 24. Strip 10 is placed along side seam 26 at a predetermined position such that pants 24 can be folded and stacked with indicia 16 appearing on the outside fold of the pants, thus permitting a customer to readily see the size of each pair of pants in the stack. For example, if pants 24 are to be folded in half for storage or display, strip 10 is adhered to pants 24 at approximately the midpoint of side seam 26. If pants 24 are to be folded in thirds for storage or display, strip 10 is adhered to pants 24 approximately one-third the length of the side seam from waist 34 of pants 24.

Although the present invention has been described with respect to specific preferred embodiments and preferred methods of practice, various changes and modifications may be suggested to one skilled in the art and it is intended that the present invention encompass such changes and modifications as fall within the scope of the appended claims.

What is claimed is:

- 1. A method of size labeling a pair of pants for display in a vertical stack, comprising:
  - printing sizing information for said pair of pants repeatedly on a first major surface of a flexible strip of material;
  - providing a second major surface of said strip with a pressure-sensitive adhesive material suitable for

- releasably affixing said flexible strip to said pair of pants;
  - affixing said strip onto a leg of said pair of pants with said strip substantially parallel to an outseam of said pair of pants; and
  - folding said pair of pants such that said strip is affixed to an outer surface of said folded pants and such that said strip spans a fold of said folded pants, whereby the size of said pair of pants can be readily determined when said pair of pants is displayed in a stack of garments on a store shelf.
- 2. The method of size labeling of claim 1 further comprising:
    - mounting said second major surface of said strip onto a release liner such that said release liner keeps said adhesive material from contacting other objects prior to affixing said strip to said pants; and
    - removing said release liner from said strip prior to affixing said strip onto said pants.
  - 3. A method of labeling of claim 1 further comprising:
    - affixing a plurality of said strips onto a continuous length of silicon-coated release liner; and
    - removing each of said strips from said liner prior to affixing said strip onto said pants.
  - 4. The method of labeling of claim 3 further comprising:
    - rolling said liner and said affixed strips into a roll after said strips are affixed to said liner, whereby said roll provides a means for storing and dispensing said flexible strips of material for attachment to said pants.
  - 5. The method of labeling of claim 1 further comprising:
    - attaching a plurality of said flexible strips of material together to form a continuous length of said strips and including means for separating one of said strips from another of said strips of flexible material;
    - affixing said second major surface of said attached strip onto a continuous length of release liner;
    - detaching said strips from the length of attached strips; and
    - removing said strips from said liner prior to affixing each of said strips to said pair of pants.

\* \* \* \* \*

50

55

60

65