



US005313699A

# United States Patent [19]

[11] Patent Number: **5,313,699**

Freige et al.

[45] Date of Patent: **May 24, 1994**

[54] **METHODS FOR PACKAGING CIRCUIT BOARDS**

[58] Field of Search ..... 29/832, 840; 361/736; 174/12 R

[75] Inventors: **D. Edmond Freige, Los Altos; Richard N. Hibbs, Palo Alto, both of Calif.**

[56] **References Cited**

**U.S. PATENT DOCUMENTS**

4,700,272 10/1987 Bellamy ..... 361/736 X

[73] Assignee: **Unisys Corporation, Blue Bell, Pa.**

*Primary Examiner*—Carl J. Arbes

[21] Appl. No.: **109,883**

*Attorney, Agent, or Firm*—John J. McCormack; Mark T. Starr

[22] Filed: **Aug. 23, 1993**

[57] **ABSTRACT**

Embodiments disclose modular packaged circuit-boards (plug-in "cards") packaged in like modules, and cooled along with a motherboard in an integrated design.

### Related U.S. Application Data

[62] Division of Ser. No. 411,427, Sep. 22, 1989.

[51] Int. Cl.<sup>5</sup> ..... **H05K 3/30**

[52] U.S. Cl. .... **29/632; 361/736**

**28 Claims, 12 Drawing Sheets**

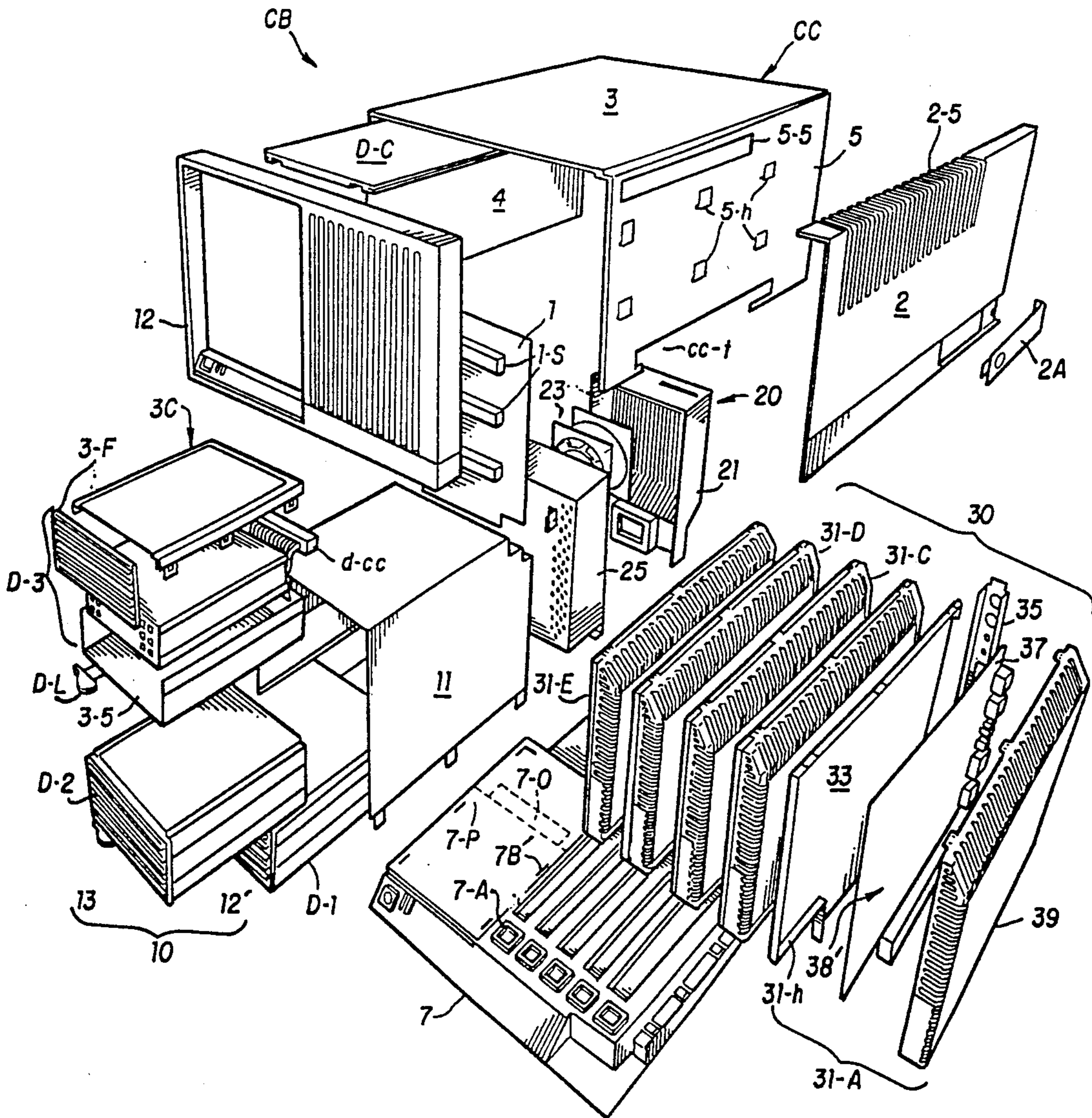

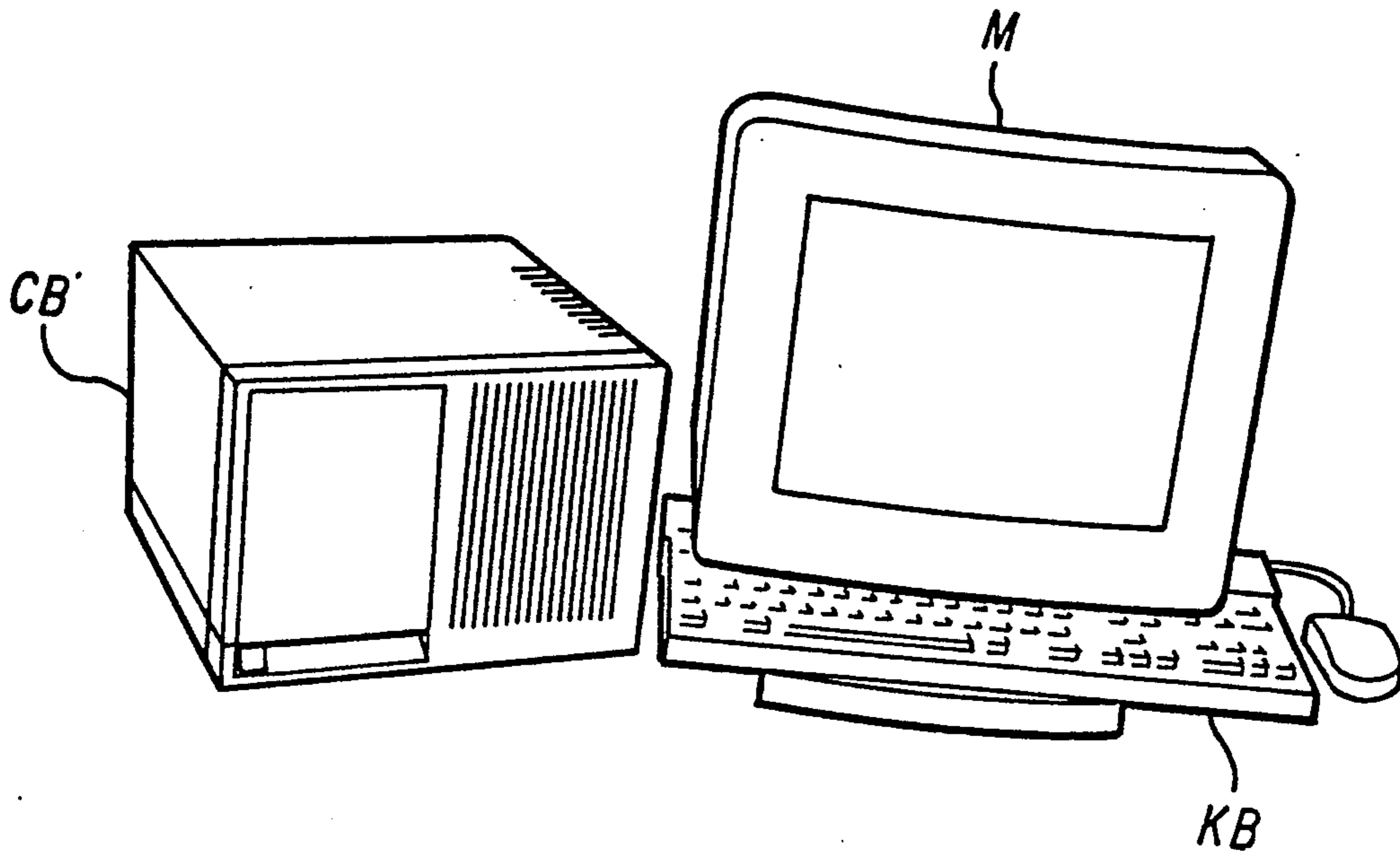

FIG. 1

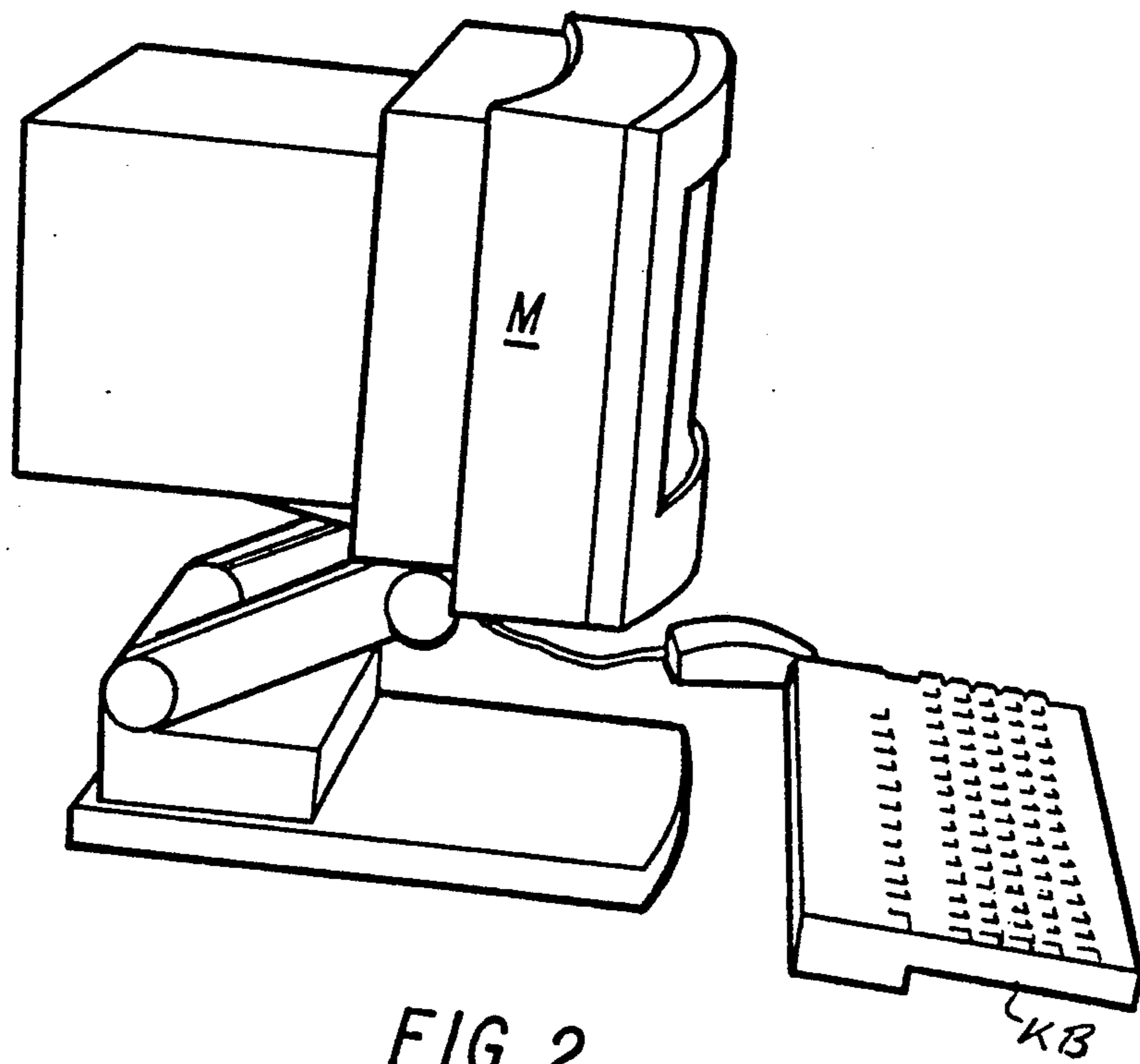
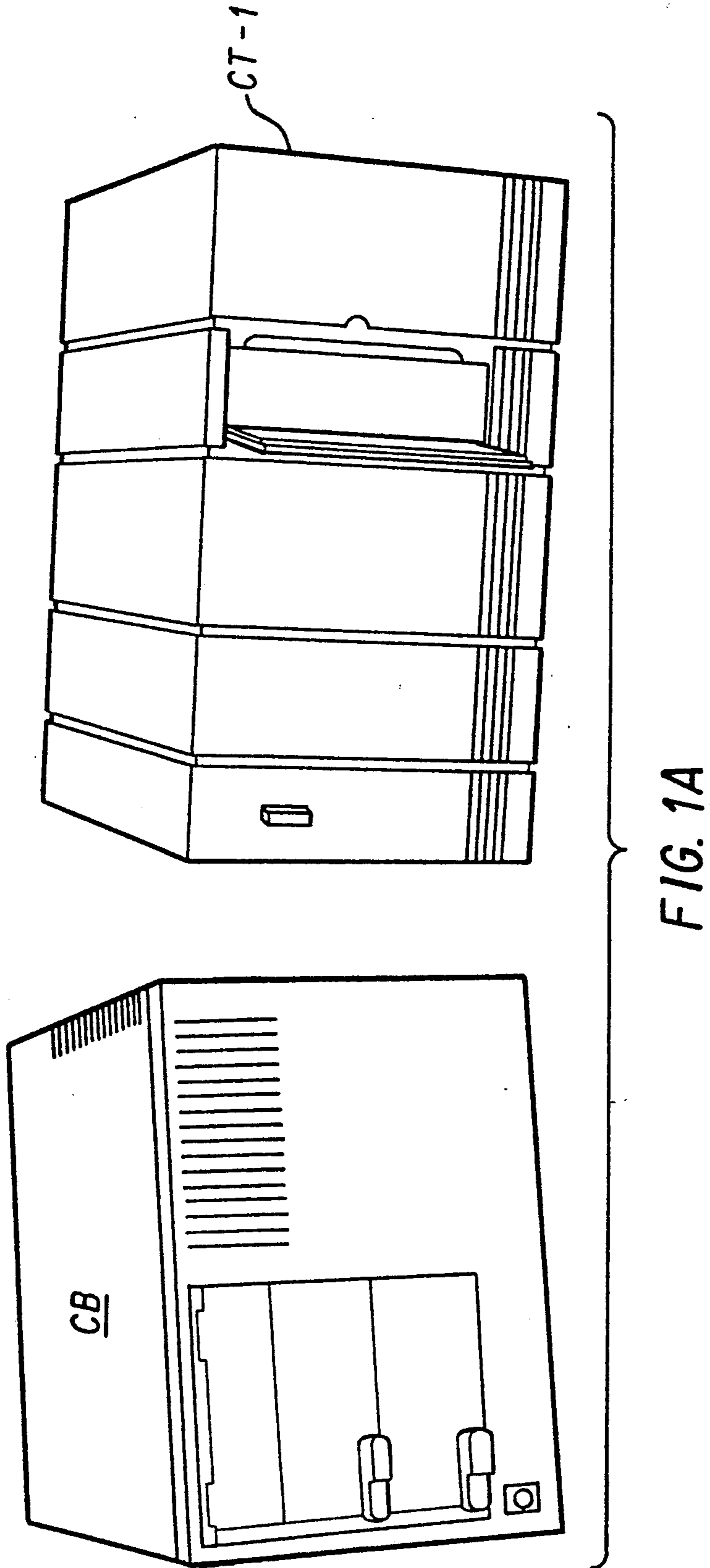

FIG. 2



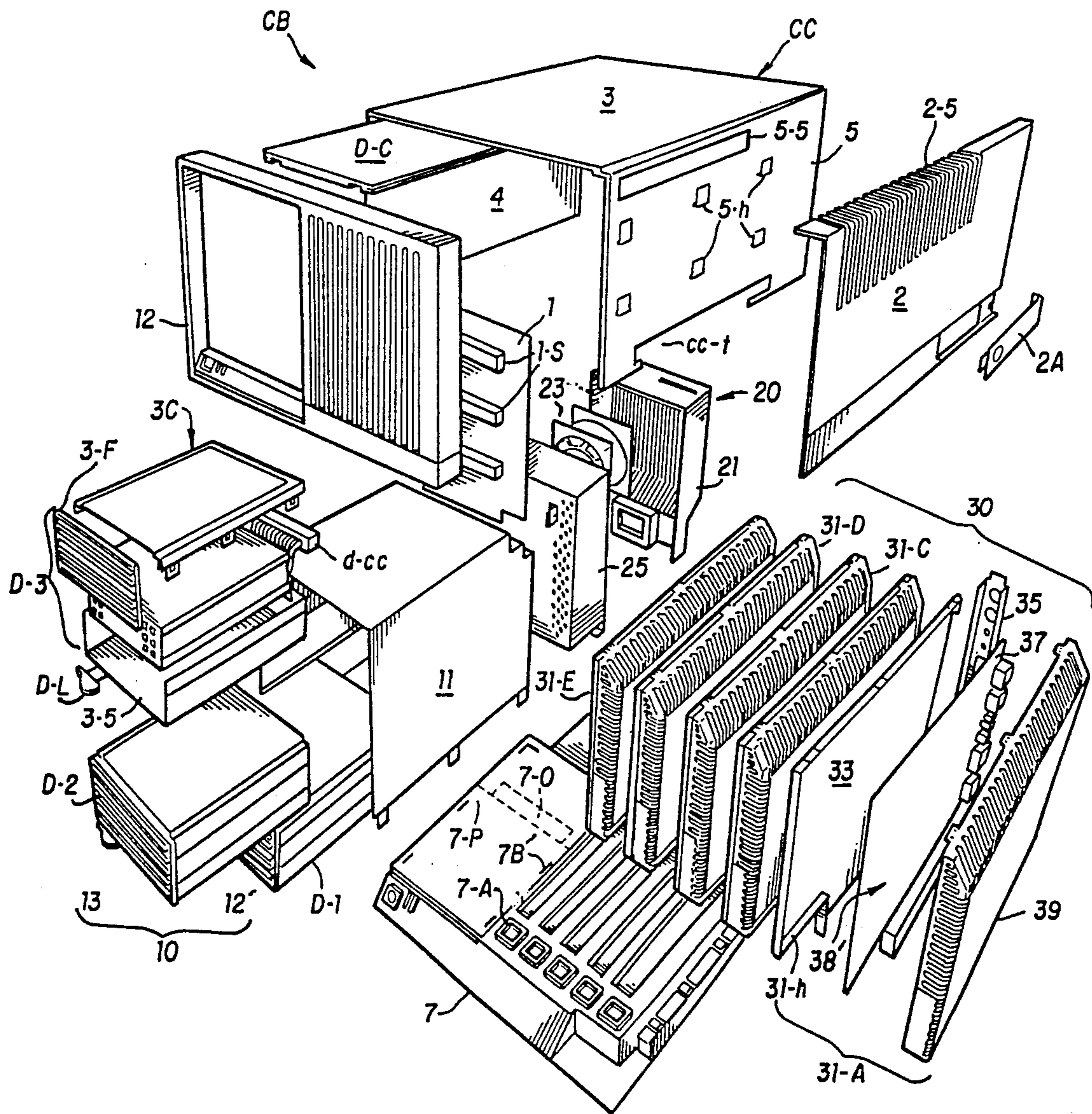

FIG. 3

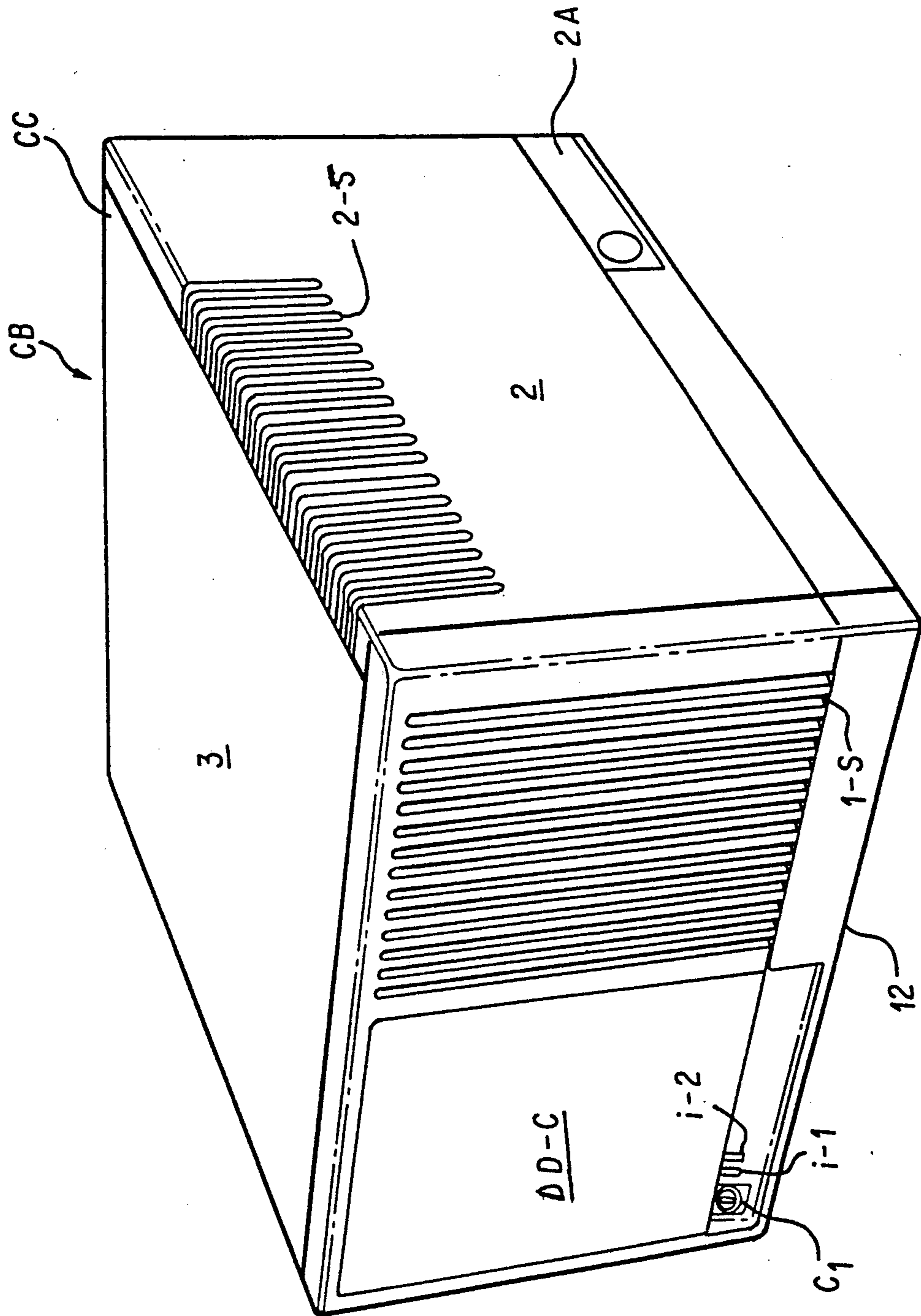

FIG. 4

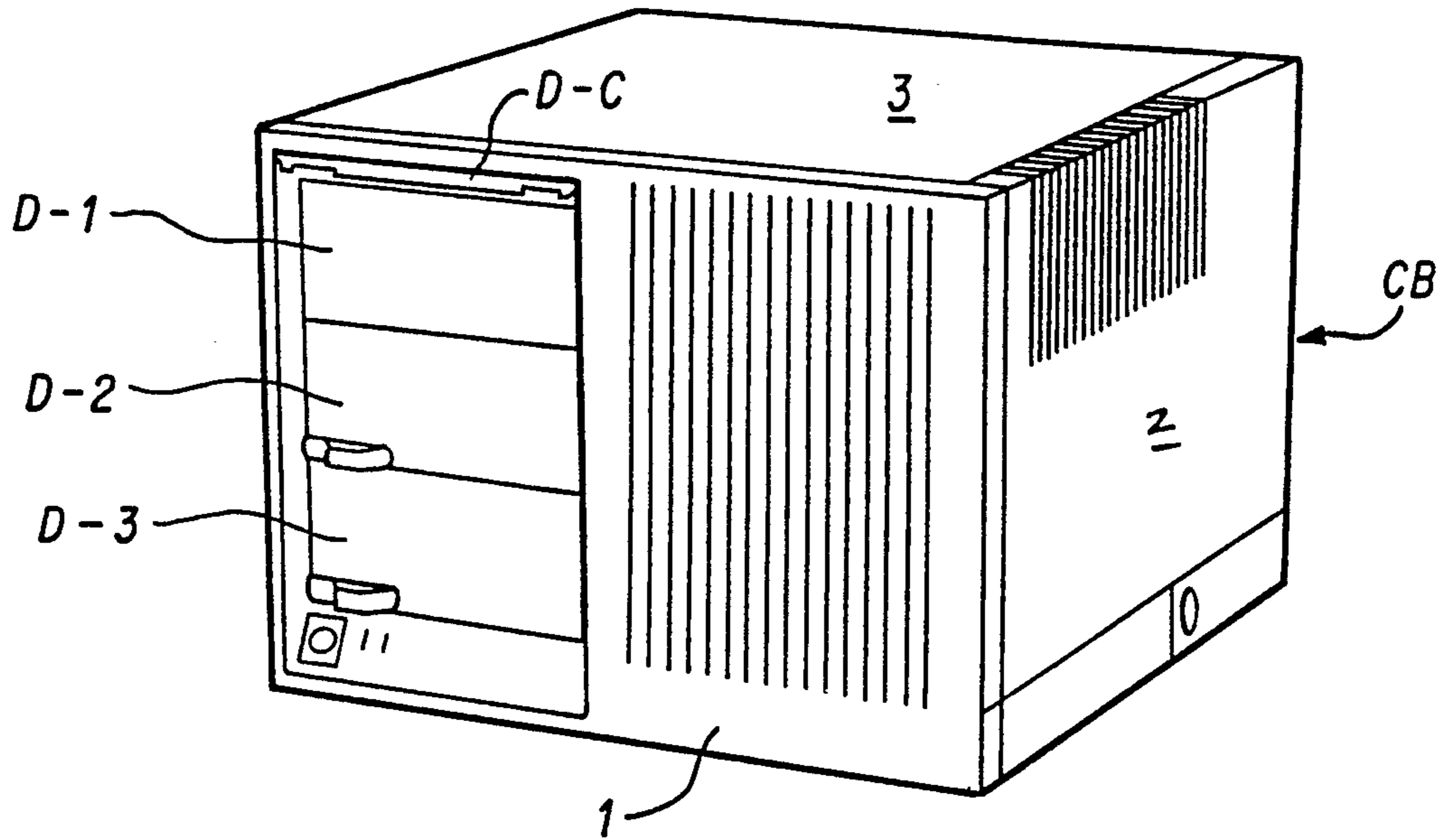

FIG. 5

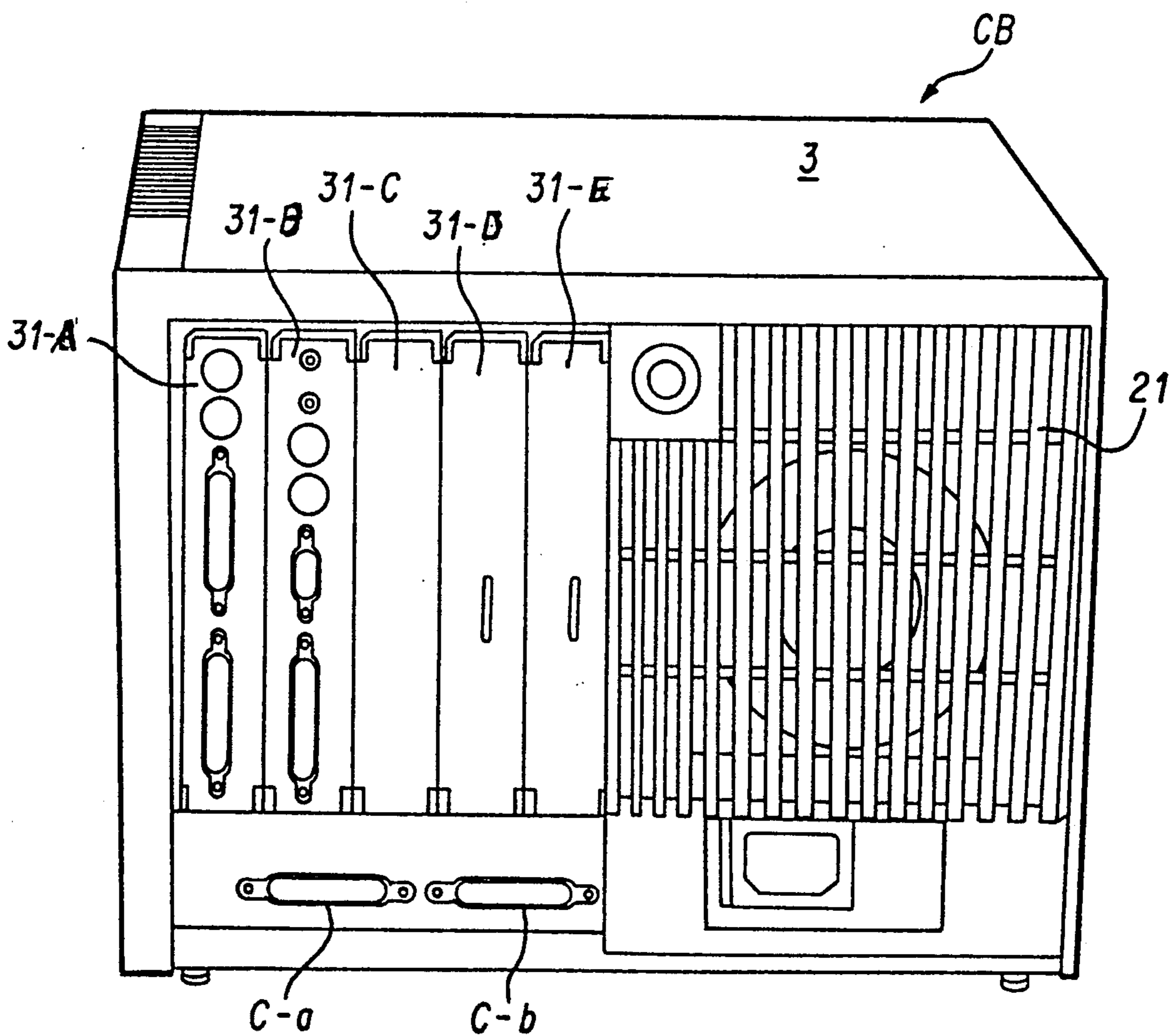

FIG. 6

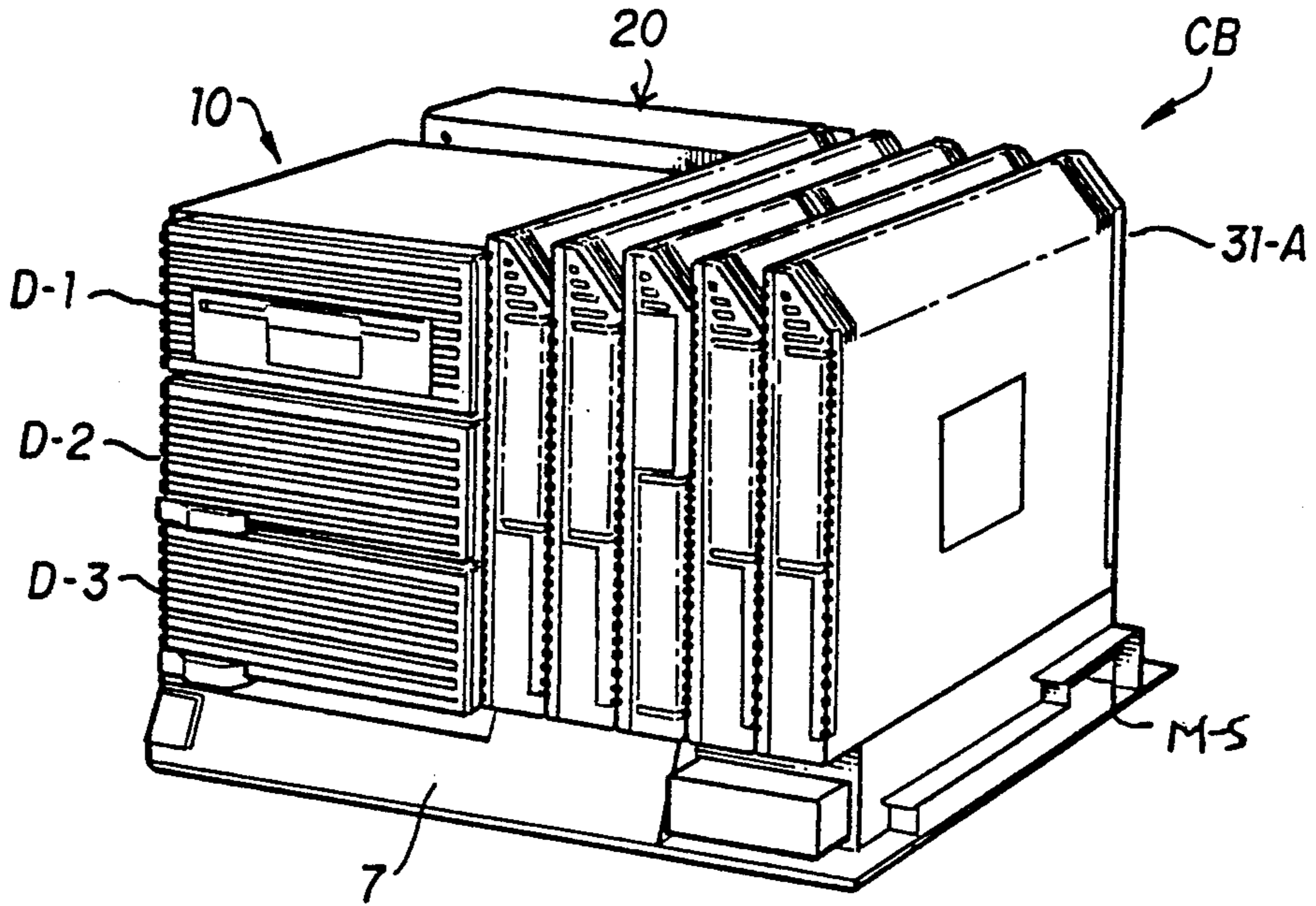

FIG. 7

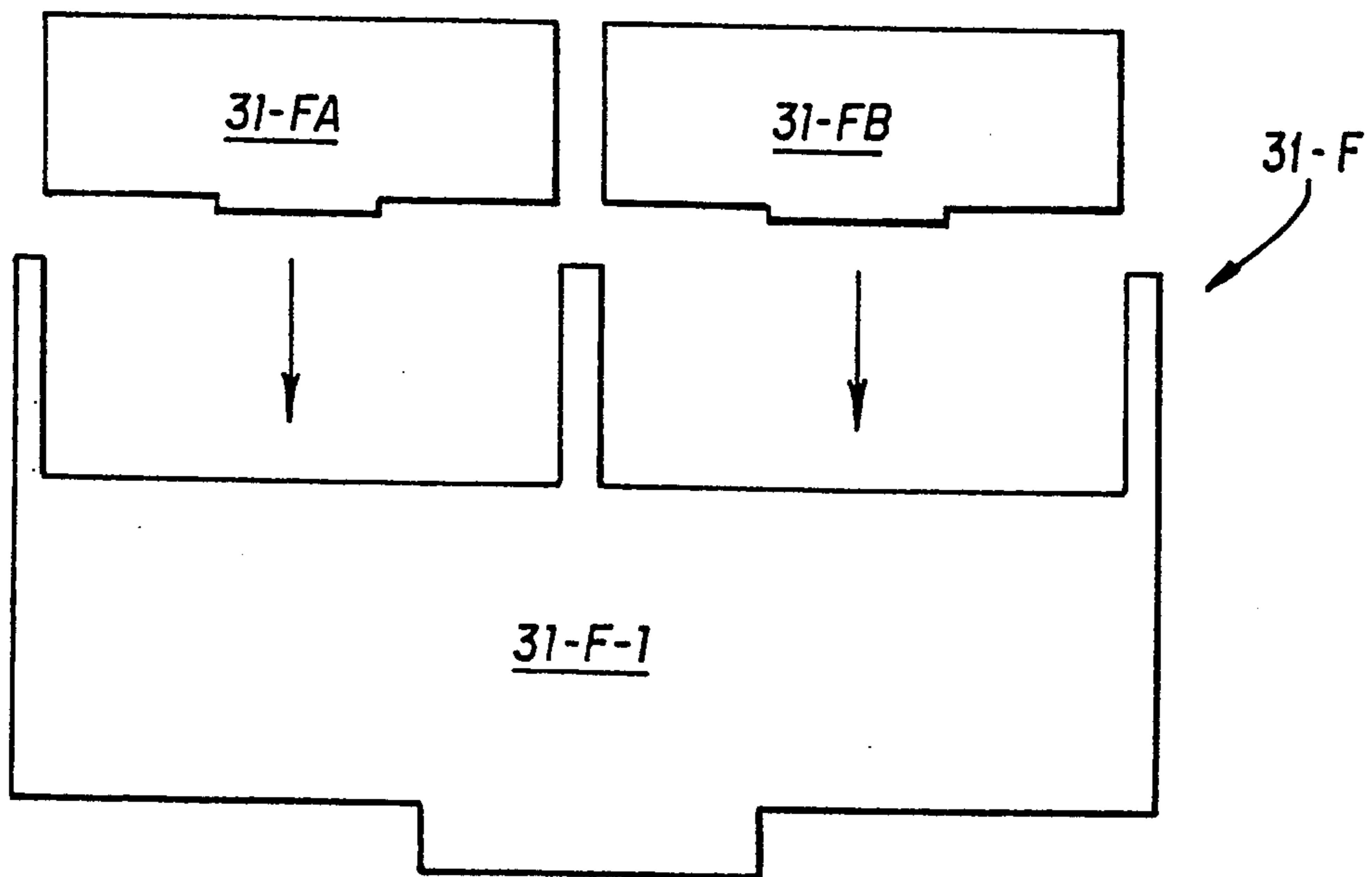

FIG. 13

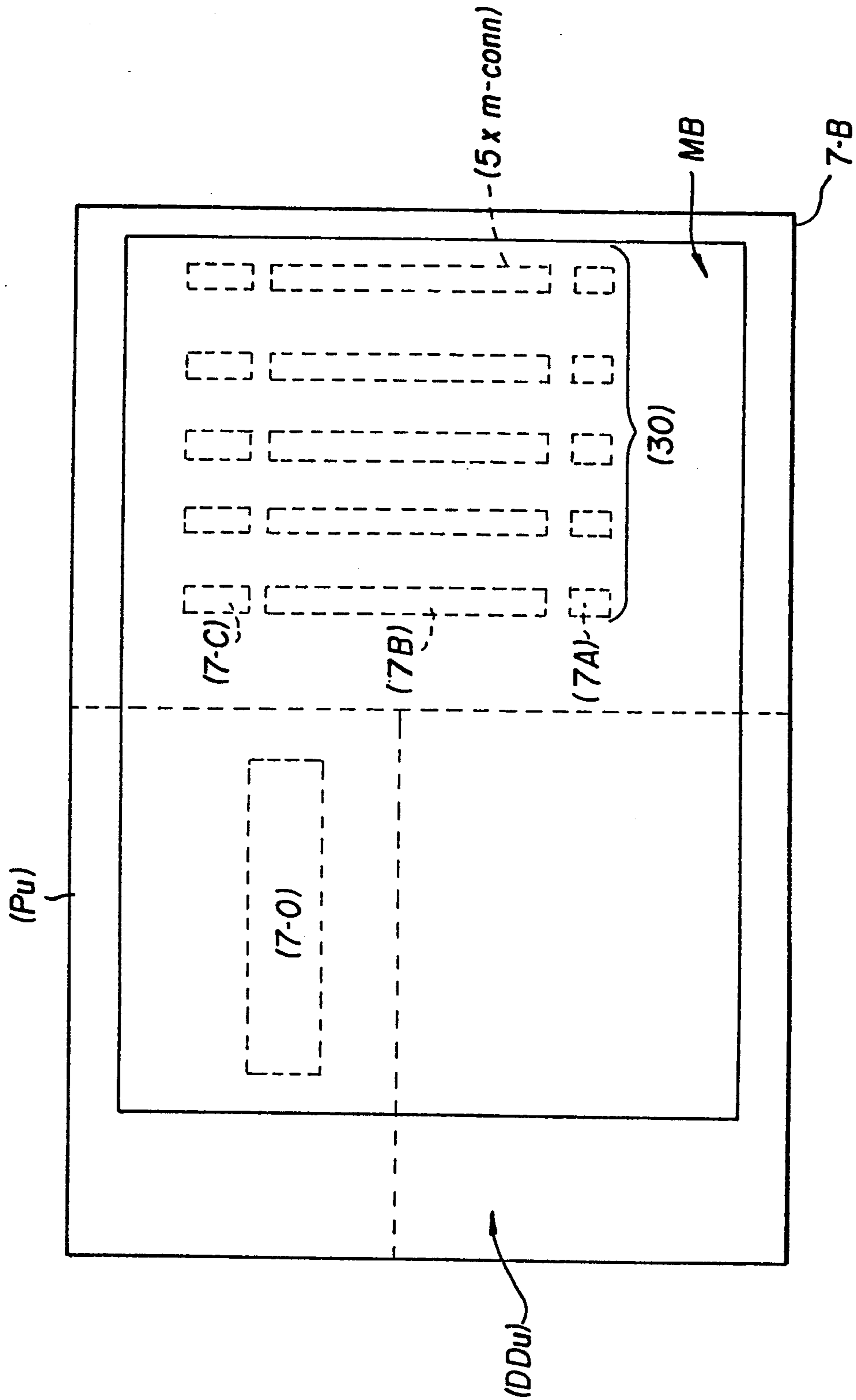

FIG. 8



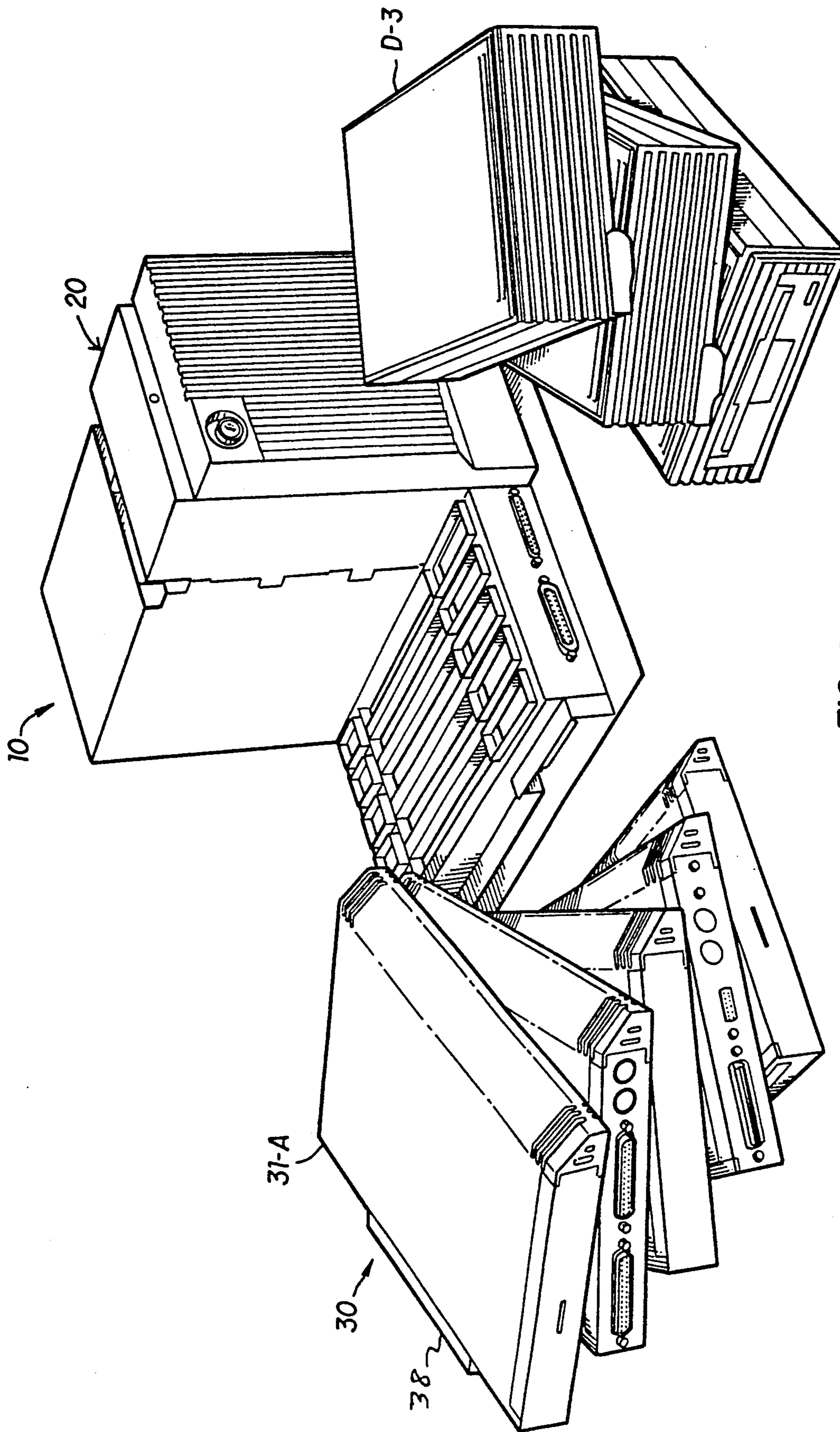

FIG. 9

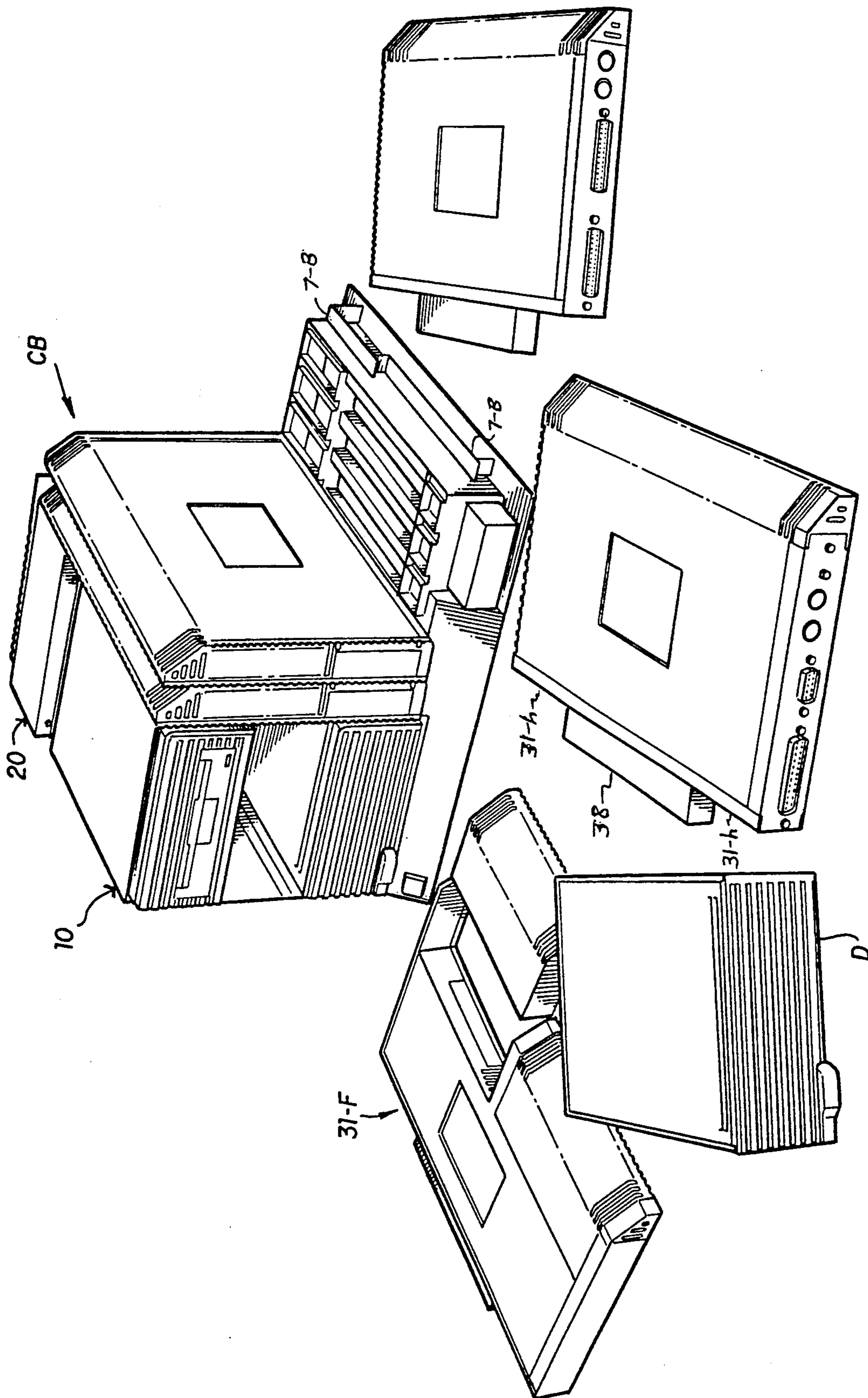

FIG. 10

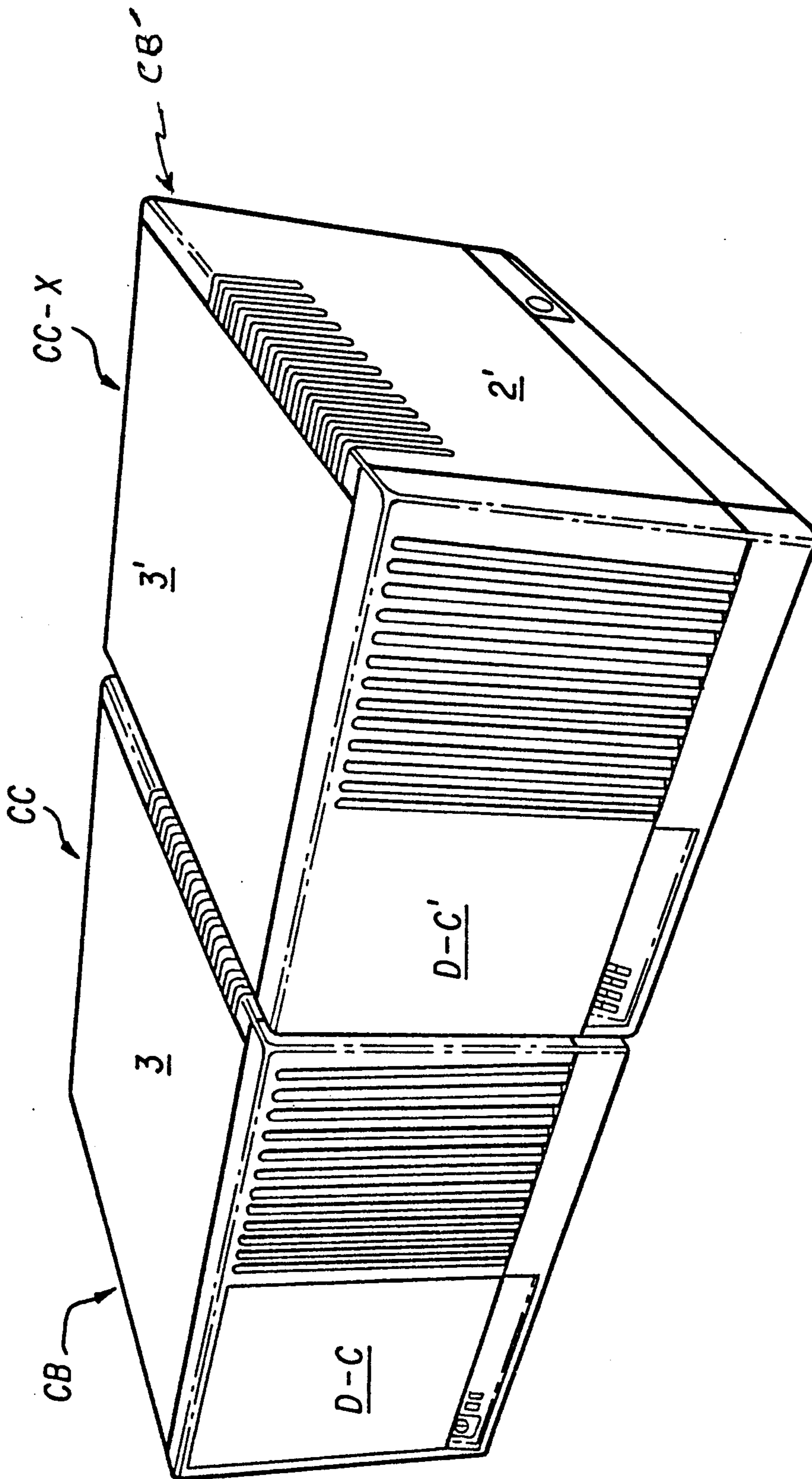

FIG. 11

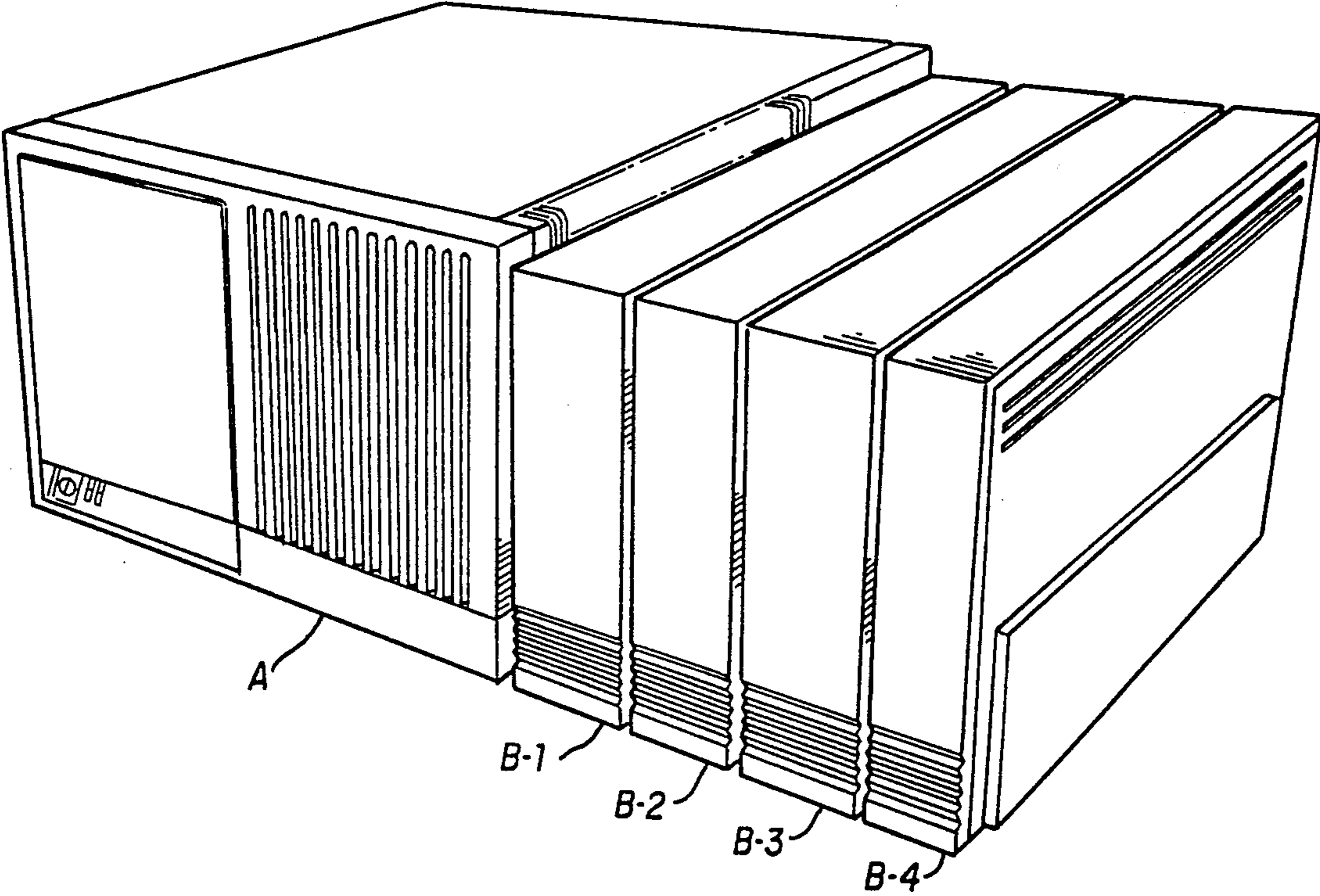
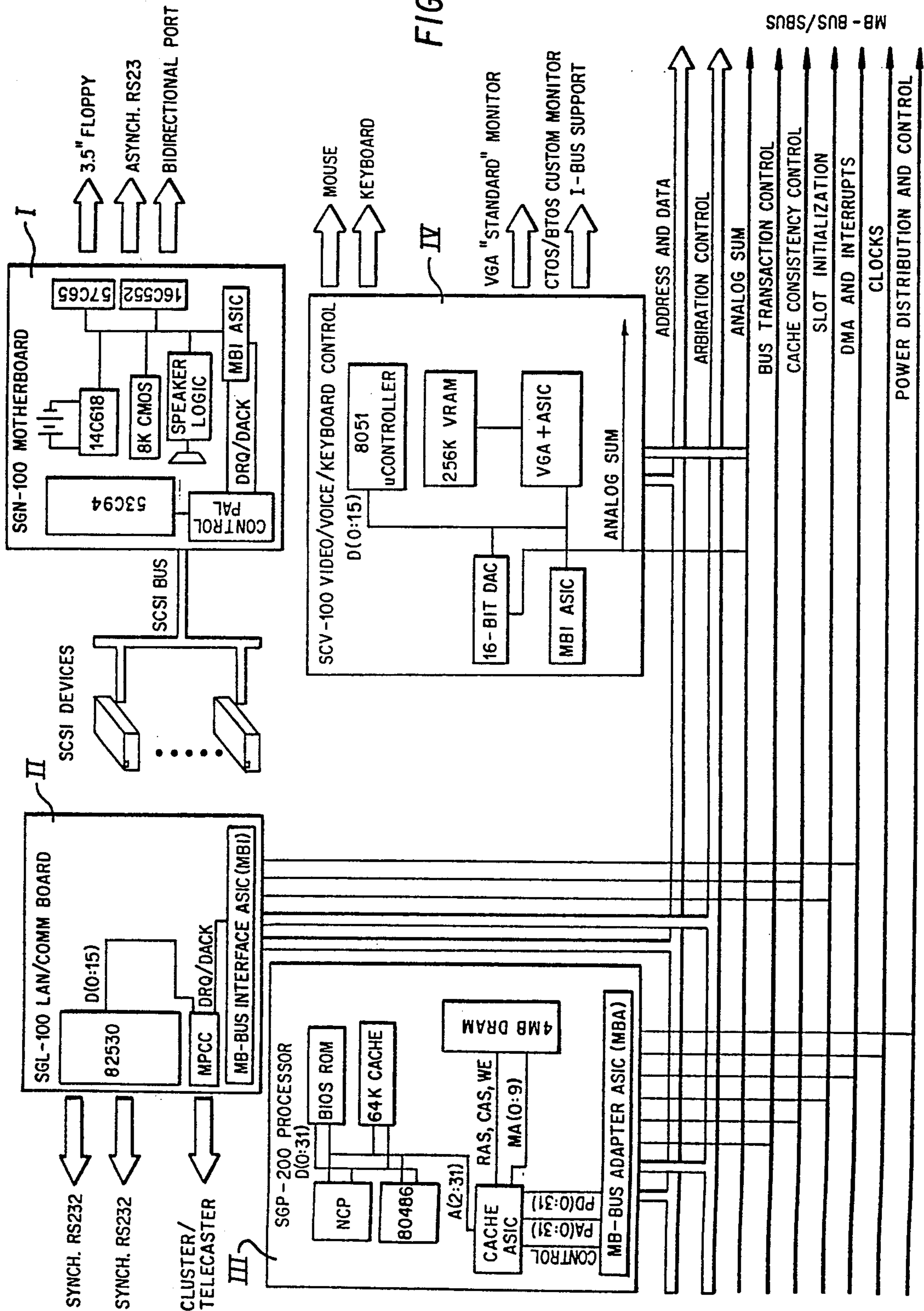

FIG. 12

FIG. 14



## METHODS FOR PACKAGING CIRCUIT BOARDS

This is a division of application Ser. No. 07/411,427 filed Sept. 22, 1989.

This invention relates to electronic circuit boards; and more particularly to packaging arrangements therefor.

### BACKGROUND

Workers in the art of making and using circuit boards know that security, safety and interchangeability are important, particularly for boards to be used in data-processing equipment.

An object of this invention is to package such boards for a processing arrangement in units that are modular, readily interchangeable and safe for handling.

One should realize that to protect plug-in circuit boards (or "cards") from abusive or dangerous handling is important. Otherwise when a user removes (replaces) a card, he might mechanically or chemically damage it. An important factor in this, and one object hereof is to avoid this by packaging all such cards in essentially identical protective plastic envelopes.

But when such cards are so confined in a protective enclosure, heat dissipation can become a problem, especially when component-density is high. Thus, a related object is to so package cards, while making the packages readily-coolable; cf. introducing inlet/outlet means for coolant-air which is directed to flow across the enclosed circuit board; while also making the package apt for air-tight, plug-in mounting on a base.

A further object is to so package and so mount the PC cards on a base, while also directing the coolant-air therefrom to wash-across a motherboard within the base. A further object is to metallize such plastic package structure to block entry/exit of electromagnetic radiation. Another object is to bevel the top edge of each such card-package to make it easier to handle and more open to air-entry.

Workers may also recognize that the organization of computer assemblies is all too apt to be complicated, making assembly and part-replacement rather complex and time-consuming. Thus, another object hereof is to segregate functional units like a disk array, the so-packaged cards, a power/fan unit and a motherboard locus, making these relatively independent, self-contained, modular and easily joined together, quickly and easily, without special skill or tools. More particularly, an object is to make such units easy to mount-upon, and plug-into, a motherboard-enclosing base. A related object is to make such a base also function as an air-coolant plenum.

A further object is to provide a snap-on cover for such an array of on-base mounted units, one that still allows the user to pick-up the array by its cover. A related object is to provide such a cover in cooperation with a disable-switch arranged to disable system power when the cover is removed.

Another object is to address at least some of the foregoing concerns and teach ways of ameliorating them.

### BRIEF DESCRIPTION OF DRAWINGS

These and other features and advantages of the present invention will be appreciated by workers as they become better understood by reference to the following detailed description of the present preferred embodi-

ments; these should be considered in conjunction with the accompanying drawings, wherein:

FIG. 1 is a front perspective view of an embodiment control unit with associated monitor M and keyboard KB; FIG. 2 shows these in side-view, while FIG. 1A shows the control unit and a related add-on module;

FIG. 3 is an enlarged perspective view of the control unit with parts exploded-away for clarity,

FIGS. 4 and 5 are enlarged front/side elevations of the control unit

FIG. 6 is a rear elevation of the control unit, while

FIG. 7 is, essentially, the view as in FIGS. 4, 5 with covers removed;

FIG. 8 is a top plan schematic view of the Base portion of the control unit;

FIG. 9 is a side-rear perspective of the control unit with disk drives and card-packages removed; while FIG. 10 is a like view but from the front, with two disk drives in-place and a few card-packages in-place;

FIGS. 11, 12 are front-side perspectives of the control unit with various associated add-on modules attached;

FIG. 13 is a very schematic side elevation of a particular 3-part card package embodiment; and

FIG. 14 is a schematic Block Diagram showing how such an embodiment can be interconnected, in itself, and with related devices.

The invention will be better appreciated by workers upon consideration of the following detailed description of preferred embodiments.

### DESCRIPTION OF PREFERRED EMBODIMENTS

#### General Description, Background

The means discussed herein will generally be understood as selected, formulated, and operating as presently known in the art, except where otherwise specified. And, except as otherwise specified, all materials, methods, and devices and apparatus herein will be understood as implemented by known expedients according to present good practice.

As seen in FIGS. 1, 2 for instance, our preferred embodiment is part of a desktop computer array including a control unit CB and associated monitor M with detachable Keyboard KB. The control unit CB will be understood as comprising a base structure 7 (housing motherboard MB see FIGS. 3, 8) on which are mounted a power unit 20, a disk drive array 10 and various card packages 30 plugged-onto the motherboard.

The computer is configured for a specific application by selecting the appropriate set of functional (card) modules. Functional modules can be plugged into base 7 (as 30) or comprises a like Expansion Unit. Support for several SCSI and computer busses (other than the MB-Bus for motherboard) is provided; e.g. XBus, AT-Bus, and MicroChannel are supported. A non-MB-Bus compatibility matrix is also provided.

The computer is also modem-connectible e.g. for remote test thereof; for instance, a plant engineer may diagnose a problem remotely, by modem; and then mail a replacement part to the user.

Control Unit CB may be any convenient size (e.g. we prefer about 9" height  $\times$  12"  $\times$  12", at about 25 lbs.).

### Preferred Architecture

The subject computer is preferably a modular 32-bit desktop computer capable of containing multiple processors.

Modularity is provided by having virtually all component aspects user-installable in small functional modules (e.g. the daughter-circuitboards inside plastic enclosures 30 functioning as modular envelope or packages for circuit cards). Another major element so packaged is the disk array 10 (hard disk or floppy). Expansion is accommodated, to allow more functionality, by providing for add-on modules (e.g. see FIGS. 1A, 11, 12).

Five functionality modules can be plugged into the basic control unit (and/or Expansion Units), allowing for a total of ten functionality (card) modules (cf. five on base 7). Three 3½", full-height disk storage modules can be inserted into basic unit CB or into an Expansion Unit. The electronic aspects of this modular architecture allow the machine to grow from a single processor, high-performance workstation to a multiple processor, multi-tasking, high end server.

Architecture will be understood as 100% compatible with the IBM PS/2 Model 80 at the register level. Added to this architecture are a high performance cache, a closely-coupled local bus (S-Bus), a high performance backplane bus (MB-Bus) along with capability for multi-processor and shared memory/private memory. A high performance Multi-Processor Backplane Bus (MB-BUS) will accept MB-BUS modules directly, as well as XBus (expansion) modules, AT Bus cards, and MicroChannel cards through adapters.

Inside a system enclosure, i.e. the Basic Unit CB or an Expansion Unit, CPU and memory units communicate across the high speed S-Bus (a 32-bit bus running at 32 MHz, providing a maximum data rate of 32 million 32 bit "Double Words" per second, or 128 MByte/second). A Multi-Processor Backplane Bus and the MB-Bus, run between system enclosures (maximum data rate of 64 MByte/second). Cached memory on CPU modules within an enclosure is kept consistent using Modified Owned Exclusive Shared Invalid (MOESI) cache consistency protocol. Cache consistency does not expand beyond the single enclosure limit.

### Controller Unit

Controller unit CB is shown in schematic, front perspective view in FIGS. 1A, 3, with FIG. 6 showing the unit from the rear.

These Figures show the exterior of a U-shaped cover assembly CC (i.e., a pair of side members 4, 5 bridged by a connecting top member 3, with side member 4 not shown). Side member 5 includes air-entry 5-S and is covered by a side-panel 2. A front panel 12 is attached across the front of assembly CC. The rear of the machine is open as seen in FIG. 6.

Front panel member 12 is affixed (e.g. by sonic-weld) to the U-shaped cover CC (3, 4, 5). In fact, it is a salient feature of this control unit CB that essentially all parts (except transformer unit) are made of plastic, and are inter-connected by snaps or similar means, without use of screws or other threaded connectors—this giving a minimum of sharp edges. FIG. 4 shows front panel 12 (disk bay DD-C shown empty).

As best seen in the exploded view of FIG. 3, cover assembly CC encloses interior functional units which, in turn, are connected, along with cover CC, to base mem-

ber 7. Except where otherwise specified, all members are constructed of ABS or similar plastic (monitor is poly-carbonate).

More particularly, base 7 mounts, and cover assembly CC surrounds, a multi-disk-drive unit 10, a power supply unit 20 and a set 30 of insertable circuit modules 31 (5 modules shown).

Communications cables to unit CB plug onto 25-pin D-type connectors. A 25-pin female bi-directional parallel port connector and 25-pin male asynchronous "RS-232" connector are mounted on the MB-BUS backplane board. These are right-angle connectors which face the rear of base module CB. RS-485 (cluster) cables can be attached to two 8 pin mini-DIN type connectors located on the SGL-100. There are also two female 25-pin D-type connectors for connection to synchronous RS232 devices on an SGL-100 I/O panel.

Disk drive array 10 comprises a U-shaped shell 11 which is mounted, via snap-in tabs, on the surface of base 7 (e.g. see FIG. 7). Shell 11 includes tracks for slide-in mounting of three identical superposed disk drive packages, D, each including side-channel means and rear connectors, i.e. disk drive packages D-1, D-2, D-3 as known in the art (see connector card 1 having electrical receptacles 1-S and connected to receptacle on motherboard MB).

An exemplary drive package D-3 is exploded (FIG. 3) for descriptive purposes and will be seen as including a disk drive DD-3 (preferably, a 3.5" hard disk unit including lock means and electrical connectors means d-cc adapted to be mated with respective pin connector means 1-S on card 1 at the rear of shell 11, when the drive D-3 is fully inserted into its respective slot in shell 11).

Disk drive DD-3 will be seen as housed in a U-shaped vessel 3-5 (FIG. 3), being covered therein by a cap member 3C, with a facing 3-F coupled at the front to 3C and 3-5 (all members being made of plastic and snap-fit together as known in the art). Workers will appreciate that each drive D-1, D-2, D-3, will be arranged and adapted to fit snugly into its zone within shell 11, e.g. each respective vessel 3-5 being provided with lateral grooves on its two outer sides, these adapted to interfit slidingly with respective projecting side-rails along the inside of shell 11 as known in the art.

Enclosure CC (3, 4, 5, 12) has "key lock" means so that, in the locked position, the enclosure can not be removed, thus preventing functional modules from being inserted or removed (unlock" to remove). The system will operate with the key in either the locked or unlocked position.

The disk drive modules can be removed by the customer from the "Storage Module Bay" without opening the enclosure, when power is off. The drive modules have a handle to pull the modules from their Storage Bay (covered by door or cover D.C.—shown elevator and tucked away in FIG. 5).

As workers realize, each drive (D-1, etc.) is to be manually inserted and extracted from its respective position in shell 11. To facilitate this, a drive-lock assembly (and handle) D-L is provided along the base of each vessel 3-5, being adapted to be thrown from a central, "Locked" position, (as with D-3, D2 FIG. 5), to a lateral "Unlocked" position (as with D-3 in FIG. 3) when the unit is to be removed. The locking action will be understood as acting to engage/disengage connectors d-cc from respective pins in 1-S as known in the art—as well as providing a somewhat central grip for a

user when extracting the drive. The "locking action" is invoked to pull-in a drive the last fractional-inch; i.e. after insertion of the drive almost "fully-into" shell 11, displacing handle D-L from its "open" (side) position to its "closed" (center) position will automatically further-  
insert connector d-cc and the entire unit back against mating pins (1-S) and provide for firmer mechanical/electric connection as known in the art.

The disk drives may comprise any compatible units; e.g. three identical modular 3.5" full-height disk drives so enclosed in plastic—these being SCSI-compatible with self-contained controllers and data separators (e.g., 19 msec access time; formatted capacity of 40, 80, 140 Mbytes).

A SCSI bus activity indicator LED (C-1, FIG. 4) is preferably provided to be visible at the front of Controller CB even when access-door D-C is closed.

Behind disk drive array 10 (FIG. 3) and mounted on motherboard MB, beneath platform 7-P, is the Power assembly 20 including a transformer unit, surrounded by a cage 25. Behind the transformer unit is a fan unit 23, and behind the fan is a perforated plastic exhaust-screen 21 (seen in FIGS. 3, 6). Power unit 20 is electrically connectible with "house power"; it will typically provide about 200 watts and operate safely up to about 18° C. above ambient. Unit 20 feeds power to disk array 10 and motherboard MB. As indicated in FIG. 8, platform 7-P is cut-out along 7-W, 7-W' to receive Power unit 20. This gives access to under-portions, allowing fan 23 to pull air from within base 7 across motherboard MB (from right to left) and expel it outwardly through the slots in screen 21.

Thus, consider FIG. 8, a sectional plan view of base 7 below deck 7-P, schematically depicting motherboard MB set on the bottom 7-B' of Base 7 and adapted for engagement with manually-inserted "daughter-circuit" cards 3 (five connectors 7B shown in phantom). Coolant-air will be assumed as drawn into each card 31, thence down onto motherboard MB via ports 7A, 7C, and across MB to exit toward fan 23 and out through screen 21.

Thus, each such card module 31 includes a base tang 38 (FIG. 9) flanked by a pair of air-vent holes (e.g. at 31-h, FIG. 10) adapted to interfit, air-tight, with receiving holes 7A, 7C in deck 7-P to feed coolant-air into the plenum space over the motherboard MB. The tang portions fit into receiving holes 7B' so as to engage electrical contacts on the subjacent motherboard MB in known mother/daughter fashion.

Each such controller unit CB (or Expansion Unit) has its own power supply. These AC-input supplies provide up to 204 Watts of regulated DC output-power, and they are "auto-ranging" (i.e. they automatically adjust to AC input voltage, 115 V or 230 V nominal, with no external switch required). They will support a Power Enable (PWREN) signal allowing an external power supply to be controlled by an on/off switch on the Controller CB. The Controller CB (and the Expansion Module) has an "IEC-compatible" AC-input connector, which can be used with nationalized power cords.

The MB-BUS will be assumed to comprise a single piece, 182-contact, dual row (0.050" centers) connector. Motherboard MB has an edge connector, while card-modules 30 each have gold plated card edge-contacts. There are five MB-Bus connectors on the MB-BUS Backplanes of the Base (and Expansion) Module. Motherboard MB preferably provides the functions of: processor and memory I-O control; it may include a CPU

chip and may interface to the rest of the system via S-BUS and MB-BUS.

This computer, with its basic set of modules, preferably also includes a few physical interconnects, such as a keyboard connector, the AC connector (at rear of CB), a Cluster/LAN connector, and RS232 communications connectors.

Flanking the disk drive and power supply units is an array 30 of circuit modules 31 (five pictured), each adapted for manual insertion into, and withdrawal from, an associated connector on motherboard MB, through a respective receiving slot—in deck 7-P.

According to a feature hereof, each circuit package 31 is "modular" and identical except for its inner contents and its end-cap 35. For instance, exemplary package 31-A houses (FIG. 3) a printed circuit board 37 connected to its motherboard-contacts and its end-cap 35, being encapsulated, in "clam shell fashion", between a receiving plastic shell 39 and a mating plastic cover 33,—parts 33, 35, 39, being interconnected with snap means as known in the art. The other modules 31-B, 31-C, 31-D, 31-E are independent and essentially-identical outwardly (see also FIG. 6 showing the end-caps face-on and FIG. 7, a front view, showing the entire Controller CB without its outer covers, or "skins").

FIG. 9 is a side/rear view of Controller CB without covers. Here, note Disk drive/Unit 10 and Power Supply 20 mounted on base 7, with the three disk drives (e.g. D-3) stacked separately nearby, as are five separately stacked circuit modules (e.g. 31-A).

FIG. 10 is a similar depiction (but from the front), where two disk drives have been inserted in Unit 10, and two circuit modules inserted through deck 7-P.

#### Plenum-BASE

As mentioned, Base 7 functions as a plenum as well as to mount functional units (on deck 7-P thereof i.e. disk drive array 10, power unit 20 and circuit modules 31), while also housing bus means and motherboard MB (beneath deck 7-P). Thus, card-modules 31 may be plugged-onto MB, through deck 7-P, and may act to introduce down-flowing coolant air onto MB. Motherboard MB is preferably singular e.g. giving clock signal controls for the disk drives (via SCSI connector—e.g. a single chip with a one MB memory can be used).

Thus, Base 7 defines a plenum, or like air-capture/en-trainment-cavity, through which coolant air may be drawn by fan 23. The air is first drawn-in from outside Controller CB through its skins (slits therein); thence into each Circuit-Module 31 along the top and front-side of each,—and down through the slits in each top and side, then across the circuit parts within, to cool these, to exit through the bottom apertures 31-h flanking tang 38 into the plenum and onto motherboard MB.

It will be apparent that each module 31 will be constructed and adapted to mount its circuit board therein (e.g. see exploded-module 31-A with board-37 therein, FIG. 3), so that coolant air may be drawn-in through its slits (along top bevel-edge) and through the front upper side of its shell 39, as shown, (—e.g. "air circulation" in FIG. 3 proceeds from the top and upper left of the circuit board 37, and down across the board, to exit at 31-h, on both sides of the bottom tang 38; See also FIG. 10).

The connectors electrically coupling each board 37 to an associated receptacle on motherboard MB (not shown) are plated under but at the bottom each respective slot 7B in deck 7-P, each being flanked by coolant



exit-ports 31-h engaging the plenum-top (deck 7-P) in relatively air-tight relation.

Thus, the five identical "triple-slots" in deck 7-P are, each, dimensioned and positioned to receive a respective vent-hole pair and connector-tang portion 38, portions 38 being disposed and adapted to direct engagement with pin connectors on the motherboard below. The pin-connectors are arranged and positioned to automatically receive the associated edge-connectors of a respective board 37 as known in the art. Tangs 38 will be understood as self-aligning and self-guiding into these receiving slots and onto their pin connector). That is, these circuit modules 31 plug directly into the S-Bus/MB-Bus backplane.

The Base Unit motherboard, preferably, has six sections. The "first" dedicated to passive S-Bus/MB-Bus signal routing: The "second" contains an IBM PS/2 compatible floppy controller and connects to the storage expansion board (T-Board). The "third" contains logic to control a PS/2-compatible, asynchronous RS232 port and a PS/2-compatible bidirectional parallel port. The "fourth" contains a speaker, used for tone generation and for audio/voice output. The "fifth" contains a PS/2-compatible Real Time Clock (RTC) and a CMOS Static RAM (8 KBytes). The RTC and CMOS RAM are each provided with battery-power back-up to preserve their contents if no AC power is available. The "sixth" section contains SCSI control logic and buffering, this connecting internal storage modules to a terminal for storage devices (also see FIG. 14).

#### Assembly of Controller Unit

Referring to FIG. 3, it will now be evident that the functional units of Controller CB may be independently fabricated (e.g. completed at different sites, then shipped to a user-site, or to an assembly-site, where the entire Controller may be very quickly, and easily put together without specialized tools labor, etc—similarly for replacement parts). That is, once Base-plenum 7 is completed (with motherboard, etc installed), one can use this as a platform for mounting a completed disk drive array 10, a completed power unit 20 and completed circuit modules 31 (one to five).

Disk drive array 10 may be pre-assembled as a completed multi-drive unit before mounting on Base 7. With disk array 10, housed within shell 11, shell tabs can inter-lock (removably) with receiving slots in deck 7-P, as schematically indicated in FIG. 3 and as known in the art.

Thus, the pre-assembled units [disk drive, power and card modules] can easily and quickly be inserted onto the Base 7 in finished form (e.g. by the user)—a novel and significant feature.

#### Cover Assembly

Controller CB is now ready for application of cover assembly CC; that is the U-shaped cover 3, 4, 5 (cf. Cut-outs CC-T on sides 5, 4 are adapted to receive respective brackets 7-B on Base 7, —when cover CC is dropped onto base 7 registering the slots with bars 7—B—then slid lockingly to the "rear", that is, in the direction of the arrow on CC, FIG. 3 as see FIG. 10).

Panel 2 will be appreciated as attached via hooks 5-H (snapped-on) or the like (no screws, etc) which are "hidden".

This enhances aesthetics and appearance, while also enhancing safety of operation. Panel 2 has an array of

thru-slits, or vents, 2-5 along its top edge and upper side—these being understood as positioned and arranged to allow outside air to be drawn inward through communicating slot 5—5 in side 5, and beyond into each card module 31 (see FIGS. 5, 3). Snap-in cover 2 fits over the MB-Bus connector on that side of Controller CB (and likewise on the Expansion Unit). The SCSI connector has a separate cover which snaps-on next to the MB-BUS cover. If the SCSI cover is removed, external SCSI devices may be attached to the exposed SCSI connector with a cable. MB-Bus SCSI parts have a built-in active terminator, which removes the termination burden from the user. But, when SCSI devices are hooked-up externally, external termination must still be provided.

Controller unit CB is contemplated for coupling to a related Expansion Unit by sliding the units together and installing a removable "latch plate" (via hooks 5-h), which is provided with the Expansion Unit. One must first remove side-cover 2, however, before attaching the Expansion Unit. Cover 2 can then be similarly attached on the right side of this Expansion Unit.

Note also that front panel 12 includes air-admitting slits, at least along the upper portion of one side. These slits oppose the tops of card-modules 31 and are adapted to admit cooling-air, this being drawn-in by the fan, in and along the upper portions (side, top) of each module 31, then down into the module itself, through the slitted bevel surfaces and adjacent upper front edge thereof. This cooling air is then drawn down across the circuit board within, and down further through its exit holes flanking tang 38, through deck 7-P, across motherboard MB to the fan (in Power supply 20, being expelled through the slits in rear screen 21).

Disk drive cover D-C may now be inserted along receiving channels (not shown) under the forward portion of cover-top 3, this cover D-C being arranged to be slidably inserted therein for storage and, when withdrawn fully, allowed to pivot downward to cover the three disk drives—e.g. note that cover D-C is in the "removed" position in FIG. 4 (bay DD-C empty); but is "open" (retracted) in FIG. 5. Base 7 is provided with suitable indicators, such as controls on/off switch C-1 (See FIG. 4) and indicator lamps i-1, i-2, as well as "key lock" K-L, as above-noted.

Any disk drive module can be removed from the "Storage Module Bay" (in shell 11) without opening the enclosure cover as long as power is "off".

The "storage modules" (disk drives) are user-installable and are removable without the use of special tools. Each drive is mounted inside an identical plastic enclosure, with a handle to allow the drive to be easily removed from the system. Drives can be removed, when power is off, after the user issues a specific command for this, either while the system is operational, or when cover CC is removed. When power is off and one or more drives have been removed, the remaining drive(s) can be locked in place manually. Drives can only be inserted when the power is off, and are then manually locked-in. User feedback is provided to show that the storage modules are locked-in. A carrying case is provided to protect each drive once it is removed.

A protruding micro-switch M-S is disposed along the side of base 7 (FIG. 7). It is adapted to be closed when panel 2 is slid from left to right across side 5 (engaging hooks 5-h FIG. 3 with its own hooks to cover CC so that it doesn't come off when one lifts the entire unit by its cover. Micro-switch M-S will preferably protrude

(behind cove) and normally be in "disable" condition until panel 2 is so thrust, fully into its closed position, thereby depressing micro-switch M-S into "enable" condition (e.g. to activate the entire computer system). This is a safety feature which is preferably provided to ensure that the system cannot be operated unless the covers are in place—thus preventing insertion or removal of parts (particularly card modules 31) when the computer is "ON" or a disk drive etc is "ON".

Workers will appreciate that the system will thus not allow a card-module 31 to be inserted or removed while the system is operating. More particularly, one thus can not turn-on the system without enclosing it inside (attaching) cover CC, including panel 2. This will prevent insertion of a card during ON-time; thus, the system can not be tampered with while operating.

[Side 5 and hooks 5-h alternatively used to attach for the second, like Controller box CB' (Exp. Module) as in FIG. 11; also assume similar connectors for NGEN parts as for B-1, B-2, B-3, B-4 in FIG. 12.]

An "Expansion Controller" CB' is shown in FIG. 11 as connected to primary Controller CB. That is, primary controller CB is mechanically and electrically coupled to an essentially-identical Expansion Controller CB' (identical to Controller CB except that CB' cannot, in turn, be connected to a second Expansion Controller since this would over-extend Bus-length and thus degrade signal transmission as known in the art).

Controller CB is conventionally coupled to its Keyboard unit and to its Monitor unit (or to the keyboard via the monitor). One is free to use any compatible Monitor or keyboard with Controller CB.

Controller assembly CB thus provides complete, user-friendly, safely-handled sub-assemblies: i.e. the disk drive, power and circuit module units (as well as cover pieces). These, or replacements therefor, can be manufactured remotely from the site of assembly/use, (e.g. be shipped separately to a user in kit form, with the user doing his own final assembly and test)—yet without risk of malfunction, without elaborate directions, without needed for screws or other threaded connectors, without delicate machinery or dangerous parts being damaged by handling—and involving only the plugging-in and snap-in of a few units onto a receiving plenum—base. The safe, snap-in, plastic-enclosed sub-assemblies house and protect all delicate, "untouchable" parts. Assembly can be performed in a fraction of the time required heretofore (e.g. 1/5 the usual time would be typical) —with no internal wires to be connected, no screws, no parts to be screwed or bolted-together etc.

#### "Cooling Circuit"

Fan 23 (FIG. 3) will draw coolant-air in through the encapsulated circuit board modules 31 down into the plenum 7 and across motherboard MB. As a feature hereof, note the "top bevel" along each circuit module 31, allowing more entry-space (under top cover 3) for improved cooling-air access and better "finger-access".

A related feature is that circuit modules 31 may each be replaced by a dummy "Filler module" which is of identical external construction; acting to isolate its respective slot in deck 7-P from the plenum and the coolant-circuit, as well as to provide electromagnetic shielding, being metallized plastic as with modules 31. (cf. "Filler module" blocks-off air flow into vacant set of holes 7-A, 7-B, 7-C, FIG. 8).

Where prior art boards typically stand free and "un-encapsulated", they allow cooling-air to pass by with no

particular difficulty. But encapsulated boards, as here, are more apt to overheat, particularly where they have rather high component density; thus, circuit modules like 31 call for forced-air or similar cooling aid—as with our encapsulated modules.

Hence, this feature postulates an array of several modules on a plenum-deck 7-P, each module 31 having coolant air entrained therethrough, from top to bottom and out the exit holes, into the base-plenum. Thus, one must hydrodynamically couple the "draw" of pulling fan 23 to these several air-entrainment passages through cards 31 and deck. This is what the plenum 7-P in base 7 is designed to do.

In this particular embodiment, one must dissipate about 25 watts per card, yet experience no more than about 15° C. rise over ambient—quite surprisingly, this may be done with the arrangement described above using only one fan (e.g. about 30 CFM rating). This is quite surprising, especially in light of the fact that related prior art structures would be apt to use about 6 fans in such environments, even where less heat is generated.

#### Circuit Board Modules

Circuit board modules 31 are described above (e.g. in connection with FIGS. 3, 9, 10).

As a feature thereof, it will be apparent that they are characterized by an upper beveled edge portion (versus a conventional "square edge" configuration). This accommodates module-separation, gives a better finger-grip, and also enhances cooling as above-noted (i.e. allowing for the entrance and entrainment-circulation of coolant air along the upper card edges, —this "beveled edge" giving extended surface-area and entraining incoming air better than a "square-top", flush against a top-cover).

Workers will recognize that a salient advantage to so-encapsulating a circuit board is that no user can touch the delicate circuit board parts and damage them, though he can still readily manipulate the board within its package. Also there is no switch or jumper apparatus to connect or disconnect.

As a related feature, the board-encapsulation is made of plastic for easier handling (e.g. slower to overheat) and it is also lightly surface-metallized (all surfaces) to provide good electromagnetic shielding (e.g. as FCC regulations require, vs excess radiation output and as optimum computer operation calls for versus input-radiation). That is, harmful electromagnetic radiation is prevented from entering into the circuit area, e.g. from an adjacent board, from the Power supply, etc. and upsetting signals on the board). This metallized plastic shell is connected to ground via a connector or motherboard MB.

The plastic material preferably constitutes ABS, with all external surfaces being surface-metallized in a continuous thin film e.g. preferably by electro-less plating one or several thin films of (one or several) metal on the entire plastic exterior. The resultant metal shielding isolates a module electrically and also helps to isolate it thermally. The so-encapsulated PC boards may be relatively conventional: e.g. about 7 by 10 inches (59 square inches of useable area). A suitable MB-BUS Backplane board is 8 inches by 10.5 inches. The module boards may be four layers minimum, using fine-line trace widths and contain complete uninterrupted ground and VCC planes.

Modules 31 will be seen as attractive esthetically, being essentially identical in appearance, like books on a shelf and just as easy to handle, e.g. when inserted side-by-side on Base 7—this modularity being achieved despite differences in function and in organization of their contents.

For instance, in a typical "basic" arrangement here, the "first" module inserted 31-E (FIG. 3) might be a CPU circuit with 4 MB memory; while an LAN/Communications board might be in the second module 31-D (e.g. a 4 MB cluster connected with the master CP—e.g. to control a cluster of 15 to 30 work stations and or control an external peripheral such as a printer or FAX unit). A third module 31-C might contain a control circuit for video/keyboard operations. [—Connect to keyboard and to monitor, or just to monitor and thence to keyboard.] Other modules might contain "Expansion Memory" or an alternate or supplemental CP or an Expansion RAM.

FIGS. 10, 13 shows a "sub-modular" memory module 31-F wherein a first memory circuit board is encapsulated in a "primary" (lower) portion 31-F1; with 2 cutouts projected there-above, each adapted to receive a respective add-on, plug-in memory sub-module, —these comprising encapsulated Memory sub-modules 31-FA, 31-FB. Units within a "Standard Circuit Module Profile"). The insert-submodules 31-FA, -B are electrically connected to the basic module 31-F1.

For instance, the "basic portion 31-F1 may comprise 4 megabytes of DRAM and associated memory control, while the two plug-on expansion cartridges 31-FA, 31-FB may each contain a 4 Mbyte memory expansion board—thus yielding 12 total Mbytes of DRAM for this card slot (within a single "standard module" footprint).

Workers will appreciate how easy it is to add cards e.g. to migrate-upward and increase computer power memory, yet keep the same modular configurations of encapsulated boards.

#### Exemplary Electronics

For instance, FIG. 14 shows a functional diagram, simplified and schematic, for an exemplary, preferred motherboard/daughterboard combination. Here, Motherboard I will be seen as controlling SCSI devices and related peripherals, while three daughter-board units (II LAN/COMM, III Processor and IV Video/Voice/-Keyboard control), are coupled to associated portions of a common MBBUS/S-BUS array.

#### Conclusion

It will be understood that the preferred embodiments described herein are only exemplary, and that the invention is capable of many modifications and variations in construction, arrangement and use without departing from the spirit of what is claimed.

Further modifications of the invention are also possible. For example, the means and methods disclosed herein are also somewhat applicable to other related computer units. Also, the present invention is applicable with like modules, alone or together, for other like systems.

The above examples of possible variations of the present invention are merely illustrative. Accordingly, the present invention is to be considered as including all possible modifications and variations coming within the scope of the invention as defined by the appended claims.

What is claimed is:

1. A method of providing removeable circuit package means for use with prescribed base means that includes receiving-circuit board means and superposed deck means including slot means and deck-vent holes, this method means comprising:

arranging said removable circuit board means to include connector means arranged to be removably connected into said receiving-board means; and providing nonconductive envelope means about said removeable board means, while constructing this envelope means to house and closely surround said removeable circuit board means, and to be relatively square and include tang means projected centrally from a bottom-edge portion thereof surrounding said connector means, while arranging and adapting said envelope means to interfit with a receiving one of said slot means in said deck means, and to include vent aperture means adapted for registry with respective ones of said deck vent holes; at said bottom-edge portion of said tang means;

while, further, making said envelope means to also include upper vent means along an upper-edge portion, opposite said bottom-edge portion, and also to include cooling-vent slit means in other portions of said envelope means whereby to conduct coolant-air from upper portions thereof, down across the circuit-board means, to exit through said vent aperture means in said bottom-edge portion and onto said receiving board means for cooling thereof.

2. The method recited in claim 1 wherein said base means is adapted to receive N such package means, said deck means including N identical sets of apertures in parallel, each aperture set comprising a tang-receiving connector slot flanked by one or more vent holes; wherein N outwardly-like package means are disposed on said deck means, each in registry with a respective set of slots; and wherein the bottom-edge portion of each said envelope means is made to include vent-aperture means disposed and configured to register with said vent-holes.

3. The method recited in claim 2 wherein each said envelope means is made to comprise plastic material with a continuous metallic film disposed entirely around the envelope means so as to block passage of prescribed electromagnetic radiation.

4. The method recited in claim 3 wherein said array of package means is enclosed by cover means disposed closely-above the upper-edge portion thereof and is adapted to admit ambient air from at least one side, being drawn to the upper vented portions of the respective envelope means; and wherein the upper-edge portion of each envelope means is disposed oblique to the two extended sides of the envelope means, whereby to enhance cooling-air access.

5. The method recited in claim 4 wherein each envelope means is made to comprise circuit-board-receiving shell means together with mating cap means and edge-connector means; said shell means and cap means being identical for all package means.

6. The method recited in claim 5 wherein air-intake slits are cut along at least part of said upper, oblique edge portion of each said envelope means, as well as along other upper envelope portions adjacent thereto.

7. The method recited in claim 6 wherein "Dummy" package means without inner circuit-board means is provided to replace said package means, being similarly

configured and being comprised of metallized plastic and adapted to similarly provide said electromagnetic shielding, as well as being non-vented and adapted to plug the respective tang-slot and associated vent-holes in said deck means and thus block coolant air flow from entering the "Dummy" package means. 5

8. The method recited in claim 7 wherein the said shield metallizing of each said envelope means is made to comprise electroless deposition of a copper film on essentially all outer envelope surfaces, followed by electroless deposition of a nickel film thereon. 10

9. The method recited in claim 3 wherein at least one of said circuit-board means and surrounding envelope means is made "half-height" and made to include electrical and mechanical connector means along the upper-edge portion thereof, whereby to receive one, or two, similar package means coupled thereon in "piggy-back" fashion. 15

10. The method recited in claim 9 wherein two such similar package means are mounted, side-by-side, atop said "half-height" envelope means and are connected, therethrough, to the common receiving board means. 20

11. The method recited in claim 1 wherein said deck vent holes flank said slot means in registry with said vent-aperture means; and wherein cover means is provided surrounding said circuit-package means and disposed relatively close to the upper-edge of the envelope means, while being vented to admit cooling ambient air thereto; said upper-edge being made oblique to the envelope sides to offer extended air-entry surface, spaced away from the cover means. 25 30

12. The method recited in claim 11 wherein said envelope means is made to comprise plastic material with a light continuous metallic film disposed on all external surfaces so as to block passage of prescribed electromagnetic radiation. 35

13. The method of claim 12 for an array of N essentially-identical circuit package means, including mounting each package means in a respective one of said slots; and disposing draft means at one end of said motherboard means, so as to draw ambient cooling-air into the said vent means in each said envelope means, then down across the circuit means therein, coolingly, to exit through said bottom-edge portions, onto said motherboard means, and beyond, coolingly. 40 45

14. The method recited in claim 1 wherein the sides of said envelope means are made essentially parallel, while the top-edge thereof is cut oblique to these sides so as to facilitate manual manipulation thereof. 50

15. The method recited in claim 12 wherein copper is first electroless-plated over all of said envelopes, followed by plating of nickel.

16. The method of claim 13 wherein each said circuit package means is made to have its sides essentially parallel, while the top-edge thereof is cut oblique to these sides so as to facilitate manual manipulation thereof. 55

17. A method of improving data handling apparatus including N circuit-package means, cover means disposed about said circuit-package means, and base means including slotted deck means and motherboard means mounted thereunder; this deck means including N sets of apertures therein, each set being identical, placed side-by-side in parallel, and comprising a connector-slot flanked by one or more vent-slots; each said circuit-package means comprising circuit means including connector means, packaged in essentially-identical, non-conductive envelope means, with 60 65

each connector means arranged to be connected-into said motherboard means;

this method comprising: constructing each envelope means to house and closely-surround a respective circuit means, making each said envelope means to include a bottom-edge portion with vent means and to include tang means surrounding said connector means projected centrally from a bottom-edge segment thereof, this segment being different from said bottom-edge portion and being arranged and adapted to interfit with a receiving one of said connector slots in said deck means;

also making each said envelope means to also include vent means whereby to conduct coolant-air from upper portions thereof, down across its circuit means, to exit through said vent-means in said bottom edge portion, then onto said motherboard means for cooling thereof.

18. The method of claim 17 for an array of N essentially-identical package means also including disposing cover means closely-above the upper-edge portions of each package means, so as to admit ambient air from at least one side to be drawn to the upper vented portions of each respective envelope means; and also disposing the upper-edge portion of each envelope means oblique to the sides of the envelope means, whereby to enhance surface area and cooling-air access. 20 25

19. The method recited in claim 18 wherein each envelope means is made to comprise circuit-board-receiving shell means, together with mating cap means and edge-connector means, with said shell means and cap means being made identical for all package means. 30

20. The invention recited in claim 19 including cutting air-intake slits in each envelope means, along at least part of said upper, oblique edge portion, as well as along other adjacent upper envelope portions. 35

21. The method recited in claim 20 wherein "Dummy" package means is provided to replace one or all of said circuit-package means, being similarly configured and likewise comprised of metallized plastic, and being adapted to similarly provide electromagnetic shielding as well as being non-vented and adapted to plug the respective apertures in said deck means and so block coolant air flow there-into. 40 45

22. The invention recited in claim 17 wherein at least one of said circuit means and surrounding envelope means is made "half-height", and to include electrical and mechanical connector means along upper-edge portions thereof, whereby to receive one, or two, similar mini-package means coupled thereon in "piggy-back" fashion. 50

23. The method of claim 17 wherein each said circuit package means is made to have its sides essentially parallel, while the top-edge thereof is cut oblique to these sides so as to facilitate manual manipulation thereof. 55

24. A method of enhancing a control circuit array which includes:

one or more circuit-package means and associated receiving base means, which, in turn, includes receiving-circuit-board means having an array of N connector-receptacle means, plus deck means superposed over said board means and including vent holes and N sets of apertures, each set comprising a slot superposed above a respective one of said receptacle means plus one or more flanking vents; this method comprising:

making each said circuit-package means to comprise:

circuit board means including connector means arranged to be removably connected-into said receiving-board means; and providing nonconductive envelope means to house and closely-surround said circuit-board means, making this envelope means to be relatively square and to include tang means projected centrally from a bottom-edge portion thereof surrounding said connector means, and being arranged and adapted to interfit with a receiving one of said slot means in said deck means, said bottom-edge portion also including vent aperture means adapted for registry with respective ones of said deck vent holes;

while, further, making said envelope means to also include upper vent means along an upper-edge portion, opposite said bottom-edge portion, and to also include cooling-vent slit means in other portions of said envelope means whereby to conduct coolant-air from upper portions thereof, down across the circuit-board means, to exit through said vent aperture means in said bottom edge portion and onto said receiving-board means for cooling thereof.

25. The method of claim 24 wherein each said circuit package means is made to have its sides essentially parallel, while the top-edge thereof is cut oblique to these sides so as to facilitate manual manipulation thereof.

26. A method of providing an array of essentially-identical circuit package means for use with prescribed base means, which includes receiving-circuit-board means having an array of N connector-receptacle means plus deck means which is superposed over said board means and which includes N sets of apertures, each set comprising a slot superposed above a respective one of said receptacle means plus one or more flanking vents;

this method including: making each said package means to comprise:

plug-in circuit board means which includes connector means arranged to be removably connected-into said receiving-board means; and to also include nonconductive envelope means which is constructed and adapted to house and to closely-surround said plug-in circuit board means, while further arranging said envelope means to be relatively square and to include tang means projected centrally from a bottom-edge portion thereof surrounding said connector means, and being arranged and adapted to interfit with a receiving one of said slots in said deck means, said bottom-edge portion also including vent aperture means adapted for registry with respective ones of said deck vents;

while further making said envelope means to also include upper vent means along an upper-edge portion, opposite said bottom-edge portion, and also to include cooling-vent slit means in other portions of said envelope means whereby to conduct coolant-air from upper portions thereof, down across the circuit board means, to exit through said vent aperture means in said bottom edge portion and onto said receiving-board means for cooling thereof.

27. The method of claim 26 wherein each said envelope means is made to comprise plastic material with a continuous metallic film disposed entirely around the envelope means so as to block passage of prescribed electromagnetic radiation.

28. The method of claim 26 wherein each said circuit package means is made to have its sides essentially parallel, while the top-edge thereof is cut oblique to these sides so as to facilitate manual manipulation thereof.

\* \* \* \* \*

40

45

50

55

60

65