



US005263659A

United States Patent [19]

Carroll

[11] Patent Number: **5,263,659**

[45] Date of Patent: * **Nov. 23, 1993**

[54] **REEL SPRING FOR MAGNETIC TAPE CASSETTES**

[75] Inventor: **William M. Carroll, Milwaukee, Wis.**

[73] Assignee: **The Koller Group, Inc., Milwaukee, Wis.**

[*] Notice: The portion of the term of this patent subsequent to Sep. 13, 2005 has been disclaimed.

[21] Appl. No.: **563,431**

[22] Filed: **Aug. 7, 1990**

Related U.S. Application Data

[63] Continuation of Ser. No. 222,765, Jul. 22, 1988, Pat. No. 4,974,791, which is a continuation of Ser. No. 30,698, Mar. 25, 1987, Pat. No. 4,770,367.

[51] Int. Cl.⁵ **G11B 23/087**

[52] U.S. Cl. **242/199**

[58] Field of Search 242/199, 200; 360/132, 360/130.2, 130.22, 130.23; 206/307, 387, 389

[56] References Cited

U.S. PATENT DOCUMENTS

4,368,860	1/1983	Goto	242/199
4,436,256	3/1984	Saitou	242/200
4,449,676	5/1984	Ogata et al.	242/198
4,496,118	1/1985	Oishi et al.	242/198
4,544,062	10/1985	Maehara	242/199
4,662,579	5/1987	Gelardi et al.	242/199
4,685,638	8/1987	Satoyoshi et al.	242/199
4,717,091	1/1988	Schoettle et al.	242/199
4,770,367	9/1988	Carroll	242/199

4,773,615	9/1988	Carroll	242/199
4,819,890	4/1989	Carroll	242/199
4,899,243	2/1990	Bordignon	242/199 X
4,903,916	2/1990	Carroll	242/199

FOREIGN PATENT DOCUMENTS

55-42385	3/1980	Japan	242/199
56-103987	8/1981	Japan	
61-6978	4/1986	Japan	
2089765	6/1982	United Kingdom	242/199
2104872	3/1983	United Kingdom	242/199

Primary Examiner—Daniel P. Stodola
Assistant Examiner—John P. Darling
Attorney, Agent, or Firm—Kinzer, Plyer, Dorn, McEachran & Jambor

[57] ABSTRACT

A magnetic tape cassette has an improved reel spring, slack limiter and tape guide. The reel spring has a generally rectangular shape with first and second parallel edges extending substantially along its entire length. A flat, central base portion of the spring is bounded by a pair of transition portions which extend at an angle out of the plane of the base. A pair of outer end portions set at a sharper angle to the base complete the spring configuration. A polypropylene slack limiter applies a preloaded tension on the magnetic tape. The polypropylene eliminates the need for laminating a separate bearing material to the slack limiter. The tape guide has a semi-cylindrical, stainless steel insert attached to a plastic mounting core. The core is fastened to the cassette housing.

25 Claims, 3 Drawing Sheets

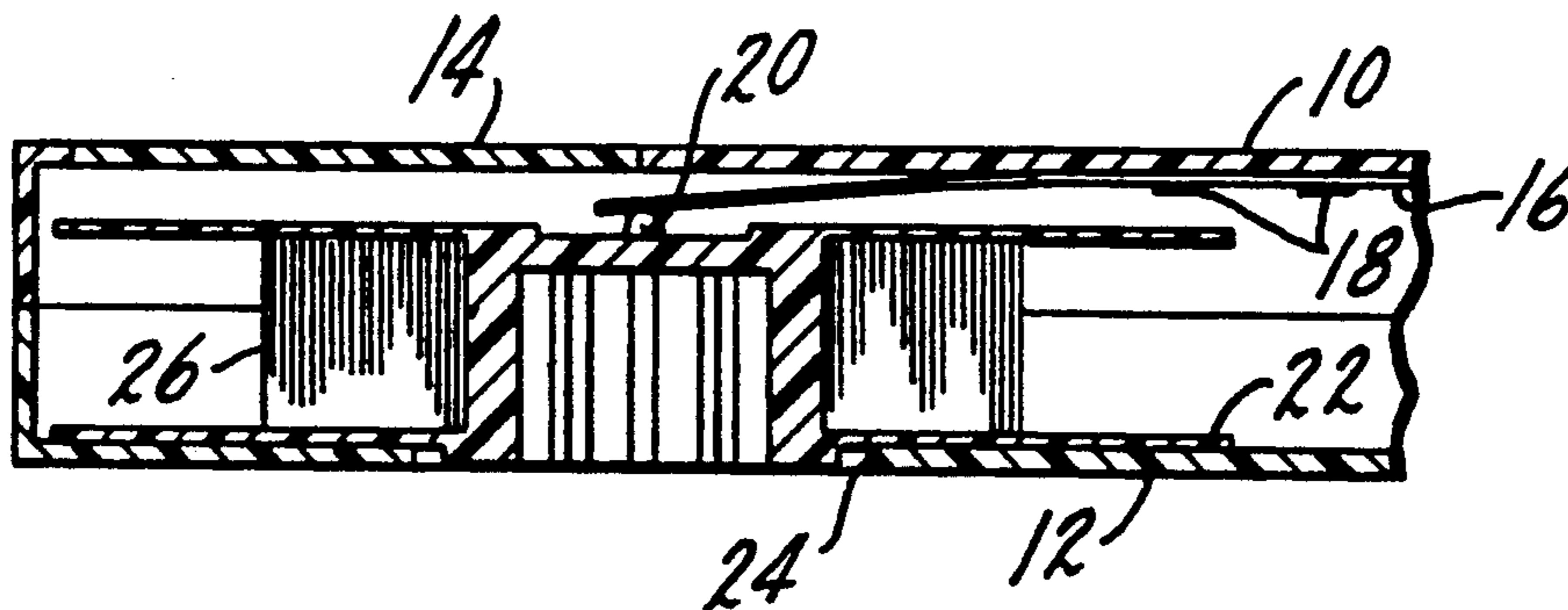

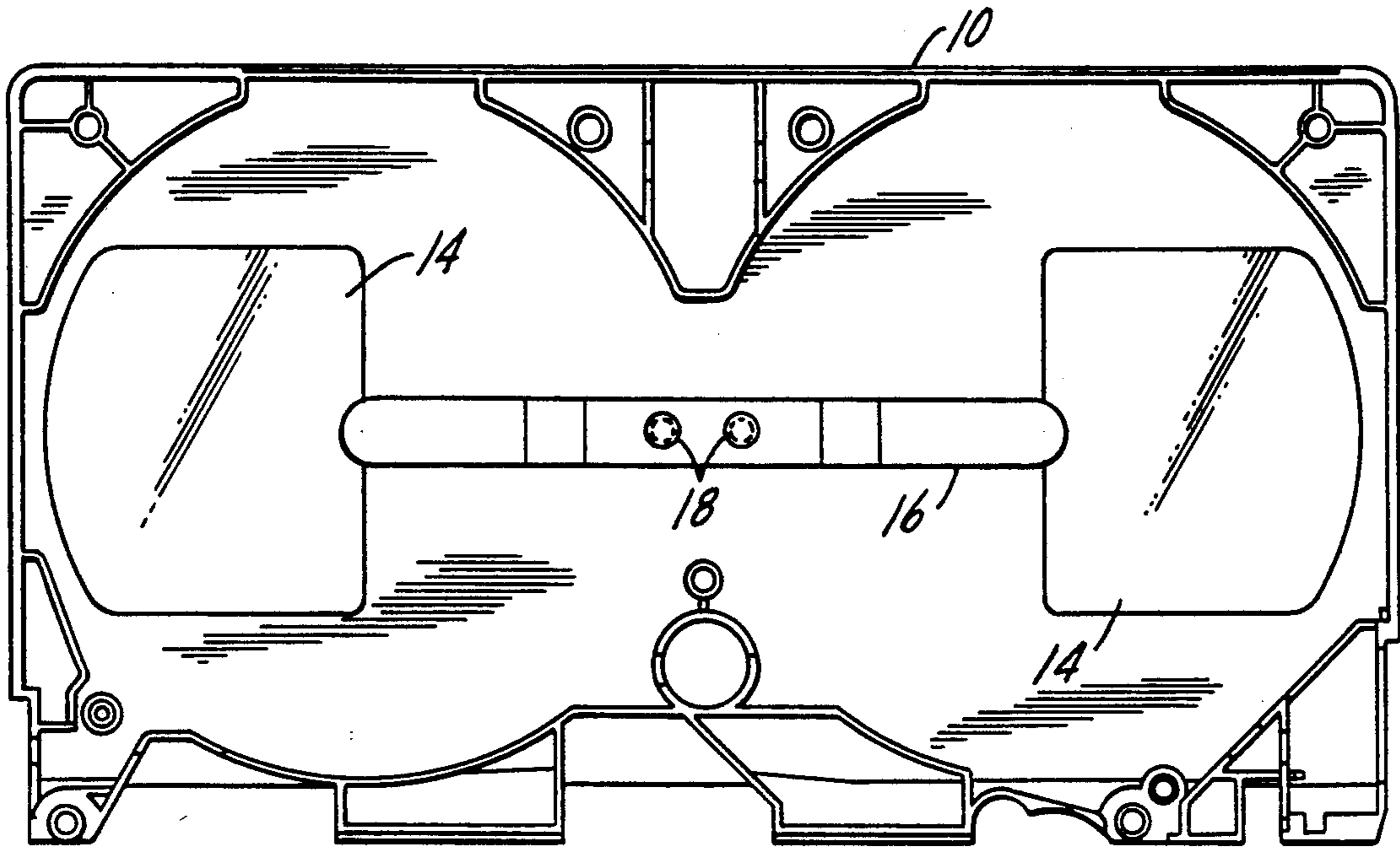

FIG. 1.

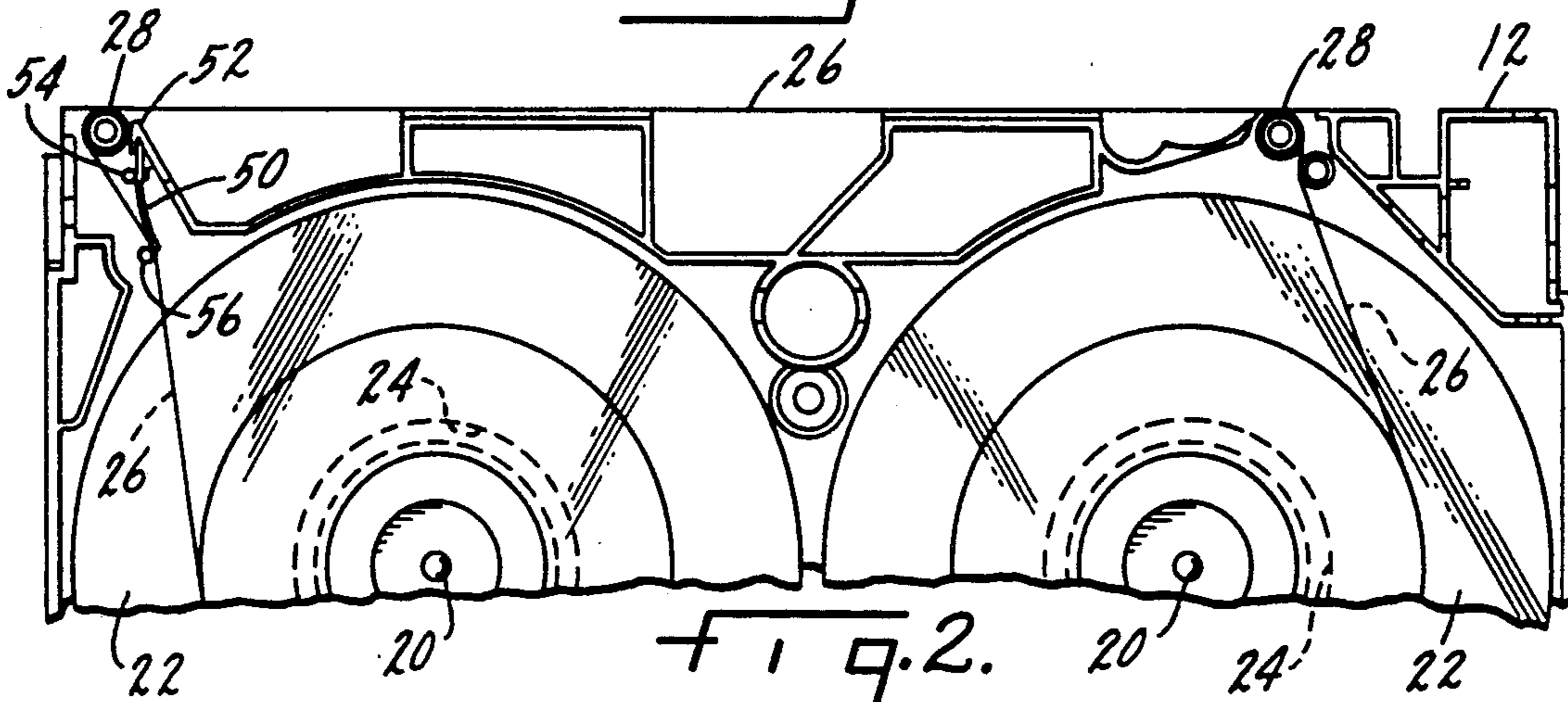

FIG. 2.

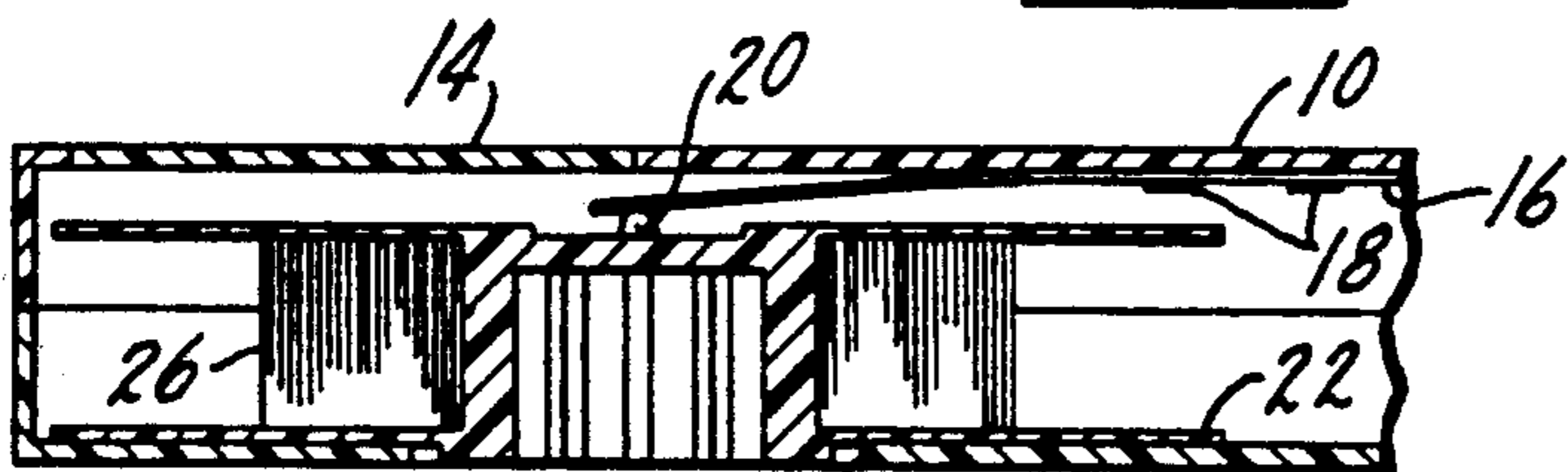

FIG. 3.

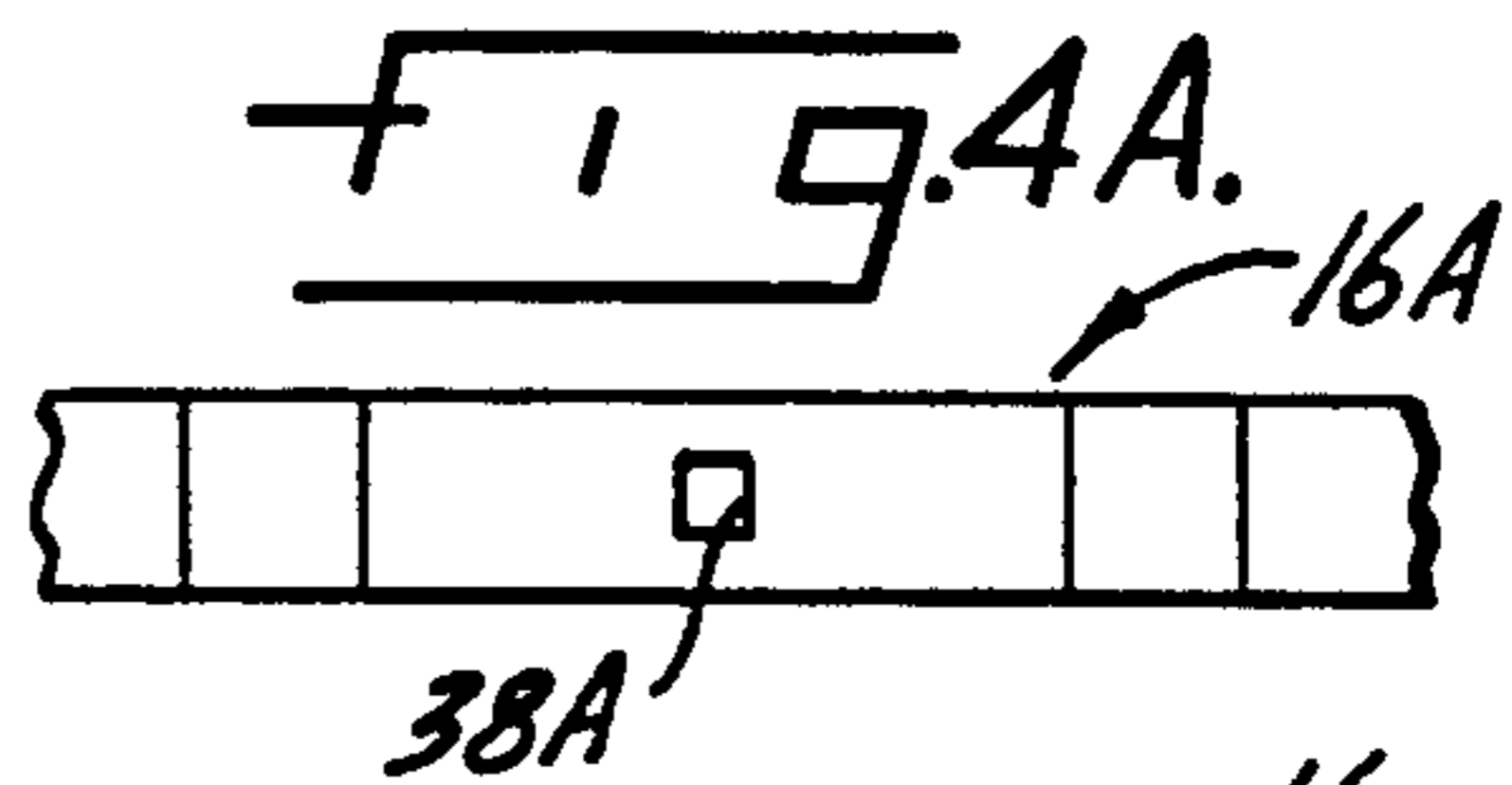

FIG. 4A.

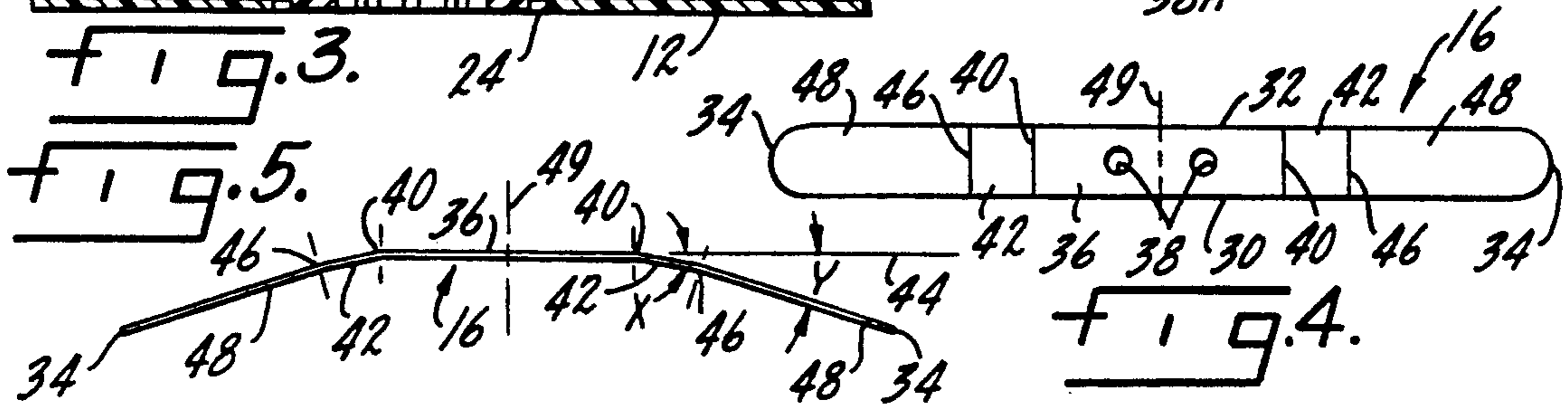
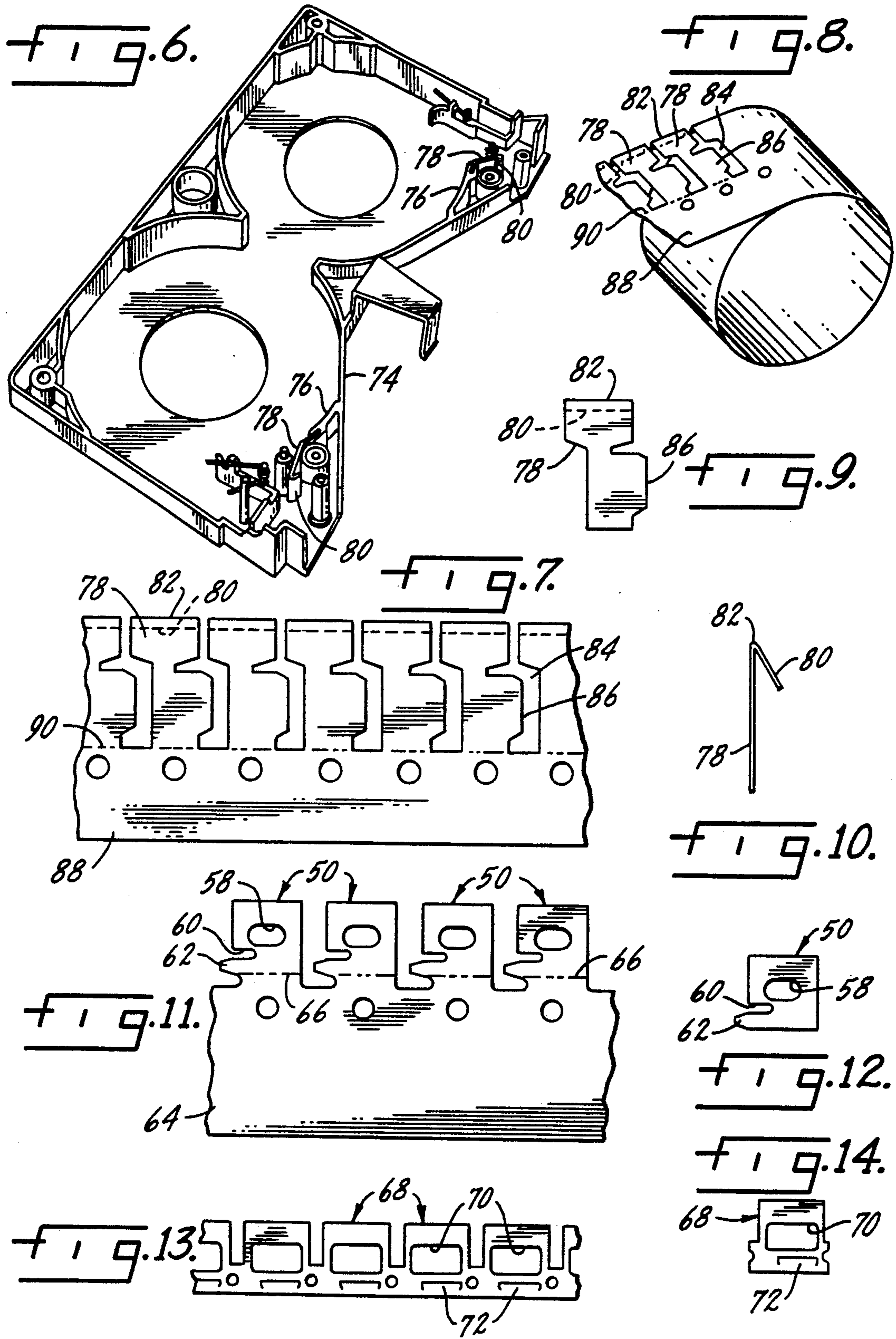
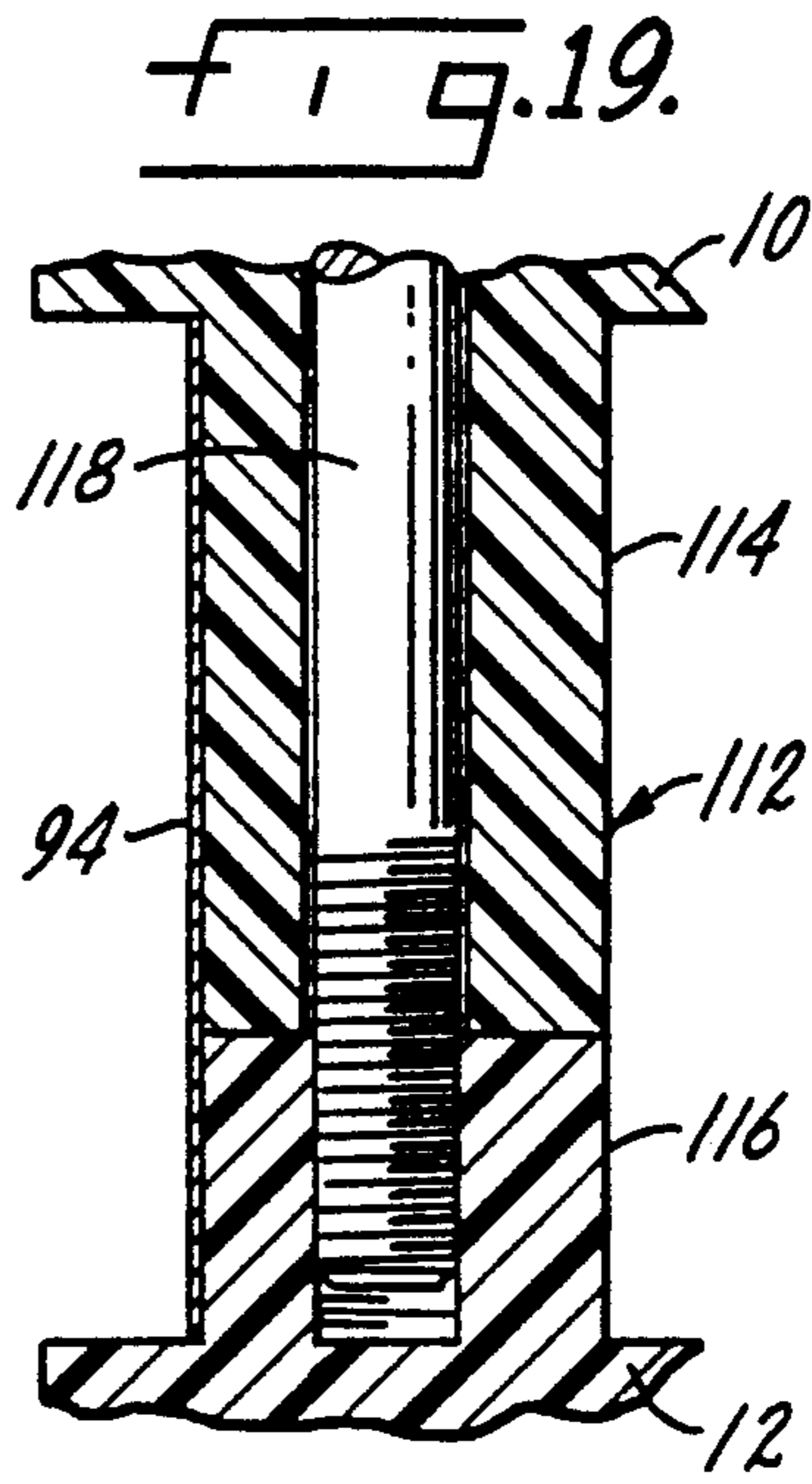
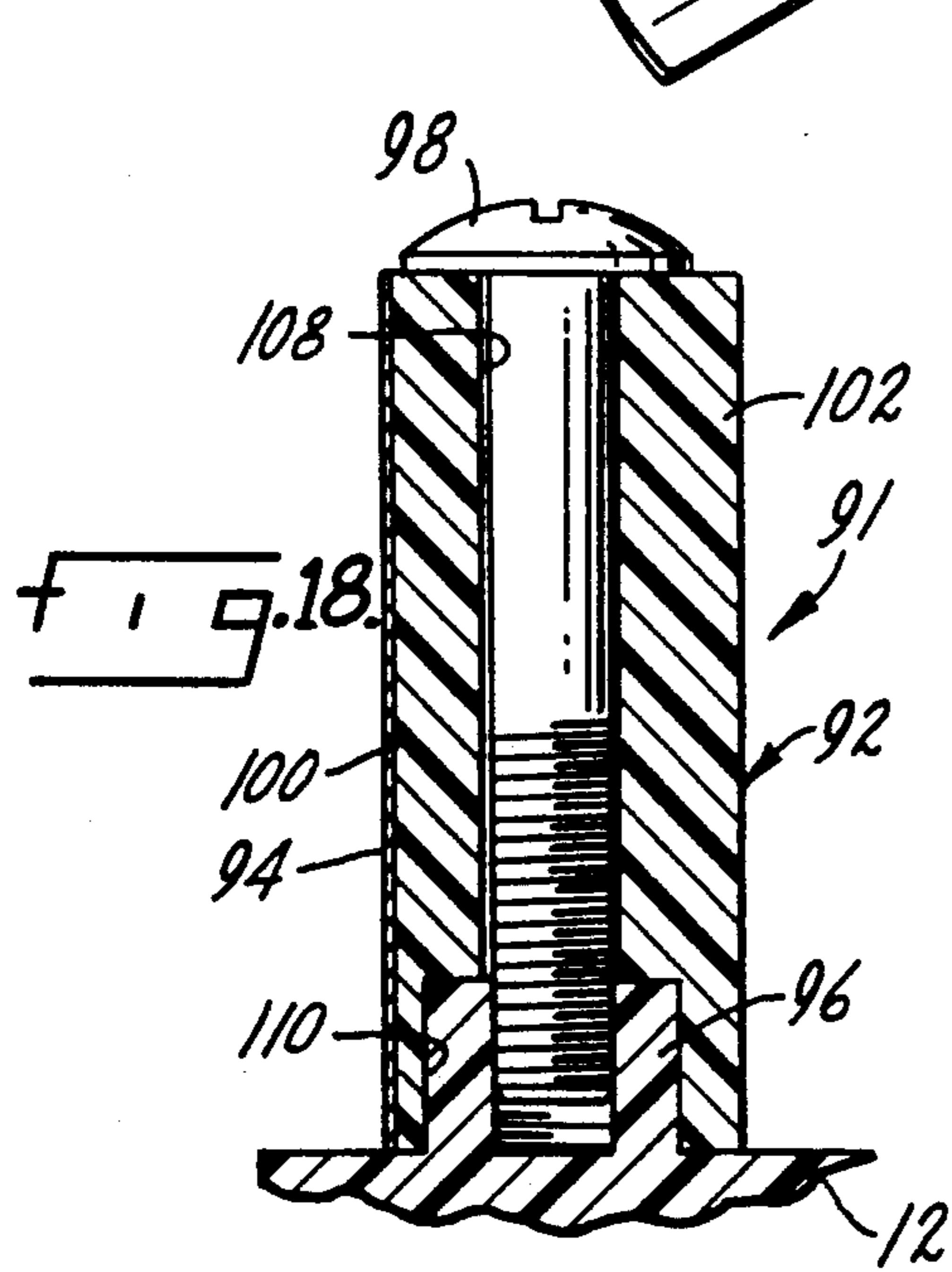
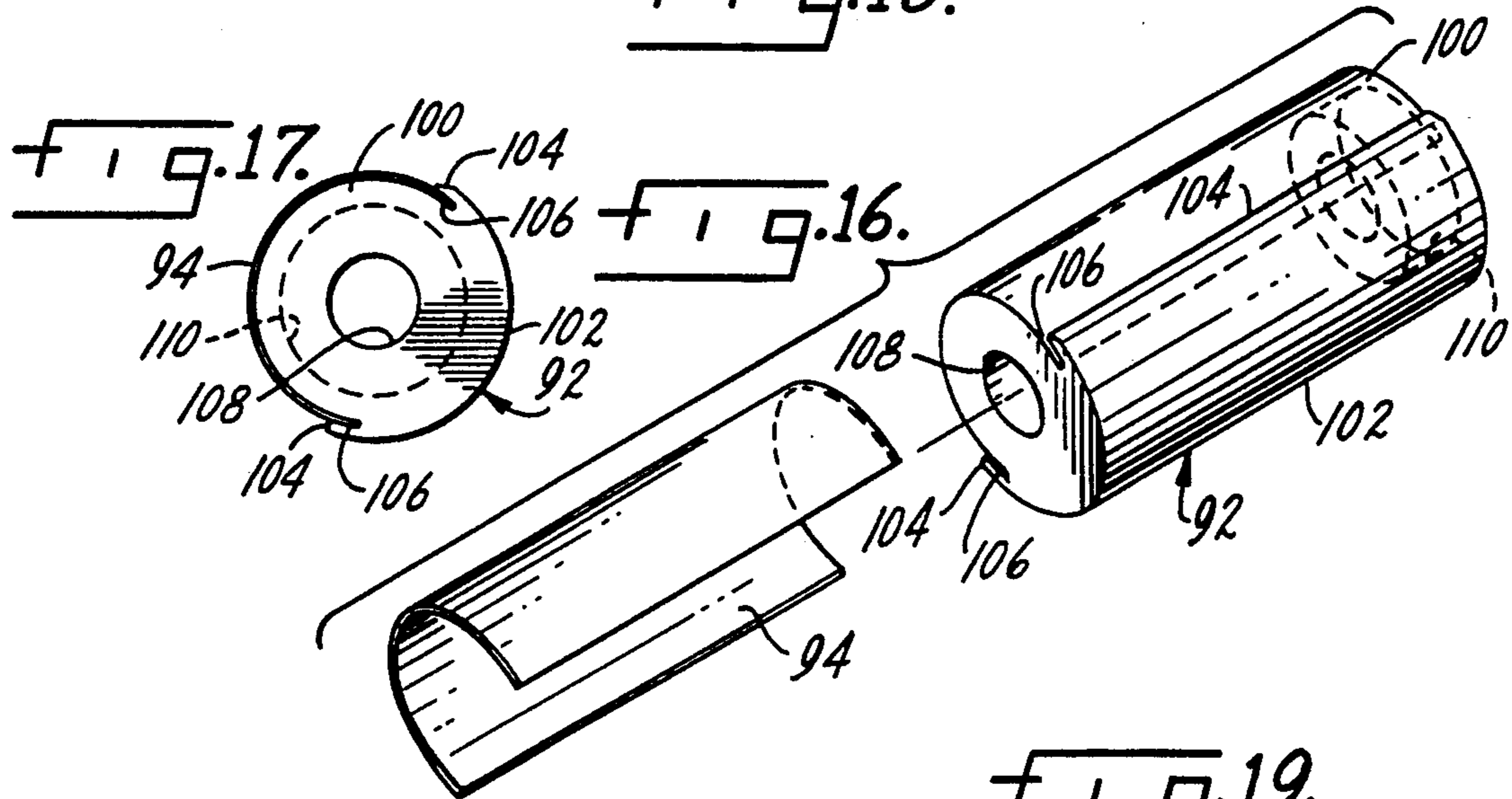
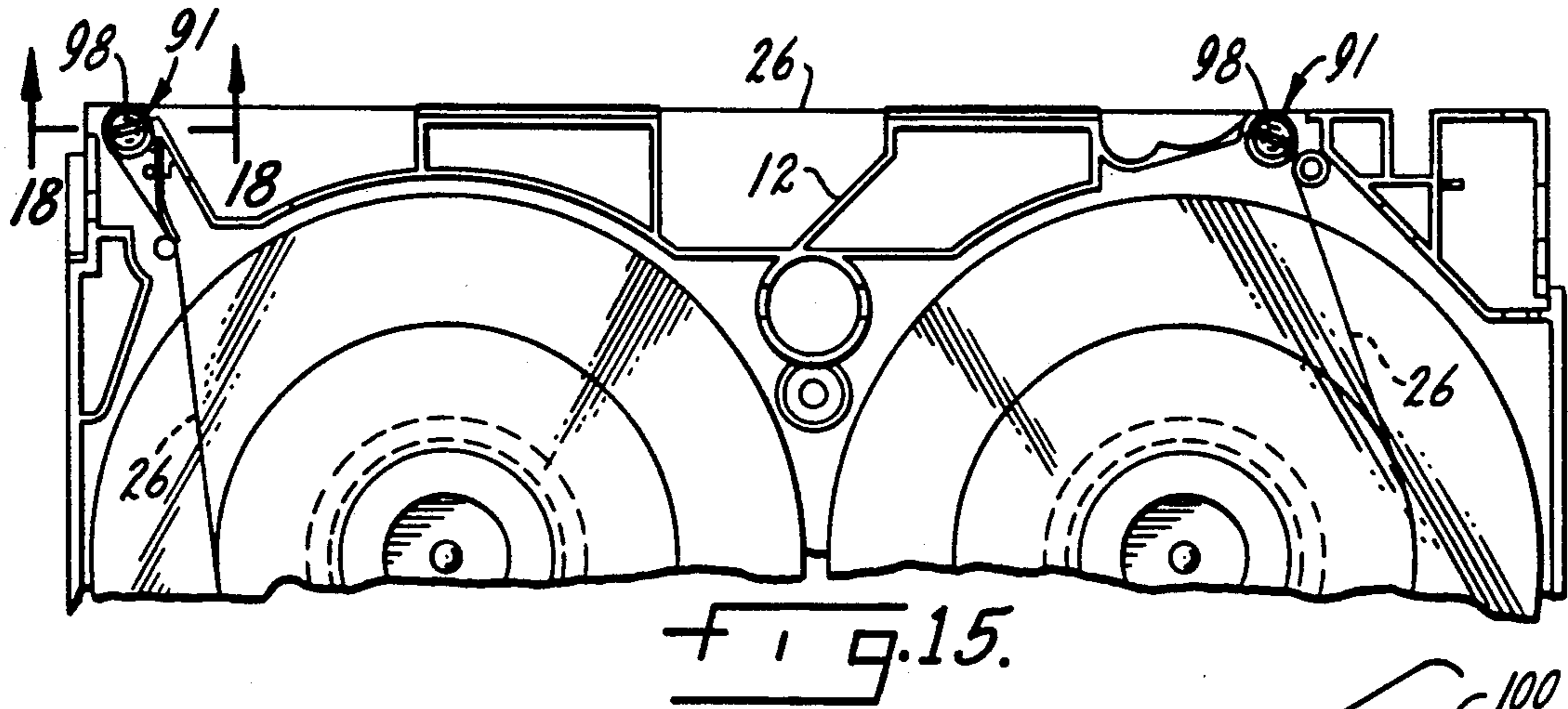

FIG. 4.

FIG. 5.





REEL SPRING FOR MAGNETIC TAPE CASSETTES

This is a continuation of copending applications Ser. No. 07/222,765 filed Jul. 22, 1988, now U.S. Pat. No. 4,974,791, issued Dec. 4, 1990, which is a continuation of application Ser. No. 030,698, filed Mar. 25, 1987, now U.S. Pat. No. 4,770,367, issued Sep. 13, 1988.

BACKGROUND OF THE INVENTION

This invention relates to magnetic tape cassettes or cartridges, such as the type commonly used in video cassette recorders. The invention is particularly concerned with a reel spring, slack limiter and tape guide for a magnetic tape cassette.

Reel springs are used in a cassette to rotatably mount the tape reel shafts. Prior art reel springs are shown in Maehara, U.S. Pat. No. 4,544,062 and Sato et al, U.S. Pat. No. 4,593,868. These springs have a generally rhombic outline, either with or without internal cutouts. One of the difficulties with such a spring configuration is the amount of waste associated with its manufacture. These springs are typically stamped out of a continuous strip of metal. With a rhombic spring outline a significant portion of the metal strip is trimmed away and discarded. Sato et al recognizes this problem and provides a spring configuration which reduces the amount of material lost. The present invention affords further material cost savings over the structure in Sato et al.

The magnetic tape cartridge will also typically include a slack limiter in the form of either a wiper tab or brake, for vhs or beta cassettes, respectively. The slack limiter preloads the magnetic tape so that it will not unwind inadvertently. The slack limiter must provide sufficient tension on the tape, but at the same time it must not generate too much friction which would cause high operating loads and excessive wear. In the past, slack limiters have been made of metal or polyester but these must be coated with polytetrafluoroethylene (ptfe) to obtain the desired frictional characteristics. This technique has two disadvantages. First, ptfе is relatively expensive and its attachment to the slack limiter adds extra steps in the manufacturing process. Second, the adhesive used to secure the ptfе to the wiper tab inevitably leaks out and contaminates the magnetic tape. An example of this construction is shown in Saito, U.S. Pat. No. 4,290,567. Saito also discloses a slack limiter having a free end portion which is bent back on itself and which is formed from a strip of suitably resilient plastic having carbon or graphite or other material which produces a low coefficient of friction at the free end. Thus, in this embodiment, Saito eliminates the ptfе bearing material.

The tape guides direct the tape's entry and exit from the cassette housing at the access opening. This involves wrapping the tape about the guides with resultant contact between the tape and guide at a substantial portion of the guide's periphery. To minimize tape wear it is desirable to have a highly polished finish on the guide surface in contact with the tape. In the past this has been accomplished by making the guide out of a polished stainless steel tube. However, fabricating such a tube or rolled stamping with its critical diameter and polished finish is a time consuming and expensive undertaking. Further, the full polished tube provides expensive material at areas of the guide which will never be in contact with the tape. Also, the mechanical

strength required of the full tube necessitates use of a greater wall thickness than required strictly for the bearing function. The present invention alleviates these problems.

SUMMARY OF THE INVENTION

This invention relates to improvements in magnetic tape cassettes and, in particular, it is concerned with the reel spring, tape guides and slack limiting devices used therein.

A primary object of the invention is a magnetic tape cassette reel spring having a shape which is simple to manufacture in high volume production and virtually eliminates material waste.

Another object of the invention is a reel spring having a simplified construction while being fully functional for its intended purpose.

Another object of the invention is a reel spring which maintains a consistent spring rate and free height and free length dimensions. Still another object of the invention is a reel spring which is readily stackable in an assembly machine hopper and which lends itself to one-at-a-time dispensing from such a hopper.

A further object of the invention is a slack limiter in the form of a wiper tab or brake which is formed from a single piece of resilient plastic material.

Another object of the invention is a tape guide which conserves expensive bearing material and assists tape alignment.

An additional object of the invention is a tape guide which is easier to manufacture and uses less material.

These and other objects which may appear from time to time in the following specification, drawings and claims are achieved by a reel spring for a magnetic tape cassette comprising an elongated strip of resilient material formed in a generally rectangular configuration. The strip has first and second parallel edges which extend substantially along the entire length of the strip. The spring has a flat, central base portion bounded by a first pair of transverse crimps or fold lines which define transition sections. The transition sections extend at a first angle to the plane of the base portion. The transition sections terminate at a second pair of transverse crimps or fold lines to define end portions of the spring which extend at a second angle to the plane of the base portion. The two pairs of transverse crimps impart an overall curved configuration to the spring.

The desired frictional and mechanical characteristics of the slack limiter are obtained by forming it from polypropylene. This material can be used without addition of a bearing strip or anti-friction material, thereby eliminating the expense of adding such a material with its attendant problems.

The tape guide has a semi-cylindrical insert of polished stainless steel affixed to a plastic core. The core is fastened to the cassette housing with the insert oriented to contact the tape as it wraps around the guide.

BRIEF DESCRIPTION OF THE DRAWINGS

FIG. 1 is a bottom plan view showing the interior of an upper cassette housing section.

FIG. 2 is a partial top plan view showing the interior of a lower cassette housing section.

FIG. 3 is partial section through a magnetic tape cassette showing one of the reels and the reel spring.

FIG. 4 is plan view of the reel spring of the present invention,

FIG. 4A is a plan view of an alternate form of the reel spring.

FIG. 5 is a side elevation view of the reel spring of this invention.

FIG. 6 is a perspective view showing the interior of a cassette bottom section.

FIG. 7 is a plan view showing a plurality of slack limiters as formed on a continuous sheet of plastic material.

FIG. 8 is a perspective view showing the payout of slack limiters in roll form.

FIG. 9 is a plan view of an individual slack limiter after having been cut from the continuous sheet of FIGS. 7 and 8.

FIG. 10 is a side elevation view on an enlarged scale of the top portion of the slack limiter of FIG. 9.

FIG. 11 is a plan view similar to FIG. 7 of an alternate embodiment of slack limiter.

FIG. 12 is an individual slack limiter after separation from the sheet shown in FIG. 11.

FIG. 13 is a view similar to FIGS. 7 and 11, showing a further alternate embodiment of slack limiter.

FIG. 14 is a plan view of an individual slack limiter as cut from the sheet shown in FIG. 13.

FIG. 15 is a partial top plan view showing the interior of a lower cassette housing section.

FIG. 16 is an exploded perspective view of the tape guide of the present invention.

FIG. 17 is a plan view of the tape guide.

FIG. 18 is a section taken along line 18—18 of FIG. 15.

FIG. 19 is a view similar to FIG. 18, showing an alternate embodiment of the tape guide.

DETAILED DESCRIPTION OF THE INVENTION

The general outlines of a magnetic tape cartridge or cassette are shown in FIGS. 1-3. The cartridge includes a case or housing having an upper section 10 and a lower section 12. The upper section includes a pair of windows 14 and a reel spring 16. The spring is fastened to the inner surface of the upper section by bosses 18 which extend through holes in the spring. The spring has a segmented arcuate configuration, as shown in FIG. 3, such that its ends contact the supporting shaft 20 of tape reels 22 which are rotatably mounted in the bottom section 12 of the case. Openings 24 are defined in the bottom case section for receiving tape reel drive shafts of a video tape player (not shown). Magnetic tape 26 is wound on the reels 22 and extends from one reel to the other past tape guides 28 and an access opening in the cartridge.

FIGS. 4 and 5 show the reel spring 16 of the present invention. As can be seen the spring is an elongated strip of generally rectangular configuration having rounded tips. The spring has first and second parallel edges 30 and 32 which extend substantially throughout the entire length of the strip. Rounded tips 34 are provided at the ends of the spring. The tip shape could be different. The important aspect is that the spring has a uniform, constant width throughout. Thus, it can be appreciated that individual springs 16 can be fabricated from a single, continuous strip of metal having the desired width. The springs can be stamped out of this strip in end-to-end fashion with only the material formed at the rounded tips 34 being trimmed away. This affords highly efficient use of the raw material. In a preferred embodiment the spring is made of stainless steel.

The spring has a flat, central base portion 36 which will adjoin the surface of the upper cassette section when the spring is installed. A pair of holes 38 are provided in the base to facilitate attachment of the spring to the cassette section. A pair of transverse crimps or fold lines 40 determine the extent of the base portion 36 and define transition portions 42 of the spring. The transition sections extend out of the plane of the base at angle X (FIG. 5) compared to the base line 44. In the embodiment shown, the angle X is 10°. A second set of transverse crimps or fold lines 46 determines the extent of the transition sections 42. Crimps 46 define end portions 48 of the spring which extend at a second, sharper angle Y to the plane of the base portion 36. In the embodiment shown, the angle Y is 17°. The end portions 48 terminate with the rounded tips 34. The crimps 40 and 46 impart an overall curved configuration to the spring. For reference purposes only, the spring is 3.937 inches long in flat condition and the tips 34 of the spring will be located 0.390 inches from the base line 44 when the spring is at rest. When the tip is deflected to a distance of 0.079 inches from the base line, the spring will apply a force of about 280-380 grams. These specifications for free length, free height and spring rate will vary from one particular cassette to another. Further specifications of a spring known to be successful are as follows. The width between edges 30 and 32 is 0.348 inches, with a tip radius of 0.174 inches. Mounting holes 38 have a diameter of about 0.128 inches and each is located about 0.207 inches from the transverse center line 49. Crimps 40 are each about 0.625 in from line 49 and crimps 46 are each about 0.938 from line 49, both measurements in the after-crimped condition. Overall length after crimping is 3.830 inches, plus or minus 0.015 inches. The stainless steel thickness is about 0.012 inches. With the spring of this invention, changes in the specifications are readily accomplished. Also, the spring configuration allows manufacture of parts that are very uniform in shape. Thus, multiple springs nest together well for stacking in an assembly machine using a pick and place mechanism.

FIG. 4A shows an alternate form of spring 16A which substitutes a single, square hole 38A for the dual round holes 38. Obviously other, non-round shapes could be used for a single hole. The spring will not turn on the square hole 38A.

Turning now to the slack limiter of the present invention, it should be pointed out that the term "slack limiter" is used herein to describe both a wiper tab used in a vhs cassette and a tape brake used in a beta cassette. FIGS. 1 and 2 illustrate a vhs cassette and the application of a wiper tab 50 therein. One edge of the wiper tab is held in a holder 52 formed in the bottom section 12 of the cassette housing. The holder presents a slot which the edge of the wiper tab slides down into. A peg 54 supplies further securement for the wiper tab 50. The edge of the wiper tab opposite the one held in the holder bears against the tape 26, urging it into contact with a pin 56. Entrapment of the tape between the wiper tab 50 and pin 56 provides the desired friction on the tape to keep it from inadvertently unwinding.

Details of the wiper tab 50 are shown in FIGS. 11 and 12. Each wiper tab has a generally rectangular shape, including a central aperture 58 and a cutout 60 forming a leg 62. The leg fits down into the slot of the holder 52. FIG. 11 shows a plurality of wiper tabs manufactured from a continuous roll or sheet of plastic film. The wiper tabs are formed along one edge of the sheet and are joined by a continuous web 64 of plastic film. Indi-

vidual tabs are then cut from the web along separation line 66.

An alternate form of a wiper tab is shown at 68 in FIGS. 13 and 14. This form has an aperture 70 and a three-sided slit forming a hinged window 72. The window can be wrapped around a peg such as 54 in FIG. 2 to further assist in retaining the wiper 68 in position. This form of wiper tab also has the advantage of reducing the amount of scrap or discarded film produced during its manufacture.

A lower housing section for a beta cassette is shown at 74 in FIG. 6. A pair of slack limiter holders 76 are built into the lower housing section 74. The slack limiters used in a beta cassette are in the form of tape brakes 78. Customarily, there are two brakes provided in each cassette. The brakes have one end mounted in the holders 76. The other edge of the tape brake includes a folded portion 80, as best seen in FIGS. 6 and 10. The fold line 82 contacts the tape. The slight radius of the fold line is helpful in reducing wear on the tape. FIGS. 7 and 8 show a plurality of beta tape brakes 78 formed on a continuous sheet of plastic film. A C-shaped cutout 84 separates individual tape brakes and forms a tab 86 which is useful in securing the brake in the housing. Individual brakes are cut from the web 88 of the plastic sheet along separation line 90.

It has been found that a suitable material for either type of slack limiter is polypropylene. This material has sufficient rigidity to apply the necessary tension or preload to the tape. At the same time, it has the desired frictional qualities without the need for adding ptfе or other bearing surfaces. Polypropylene has sufficient "memory" to provide the proper spring rate and it will retain that spring rate at elevated temperatures. Chemically it will not disturb the magnetic tape. The polypropylene slack limiter can be assembled into a cassette directly as it comes off the web of a roll. This eliminates the manufacturing processes associated with applying a separate, second bearing surface. It also eliminates the possibility of tape degradation due to adhesive leakage, due to the fact that no adhesive is required.

Turning now to the tape guide of the present invention, the environment in which tape guides are used is shown in FIG. 15. The guides 91 are located along the front edge of the lower cassette housing 12. The magnetic tape 26 is threaded around the tape guides 91 to the access opening extending generally along the front edge of the cassette. The tape guides have the precise diameter and length needed to assure tape alignment.

FIGS. 16-18 show details of the improved tape guide 91 of the present invention. Generally, the guide comprises a plastic core 92 mounting a semi-cylindrical metal tape guide insert 94. The guide is mounted on a stubshaft 96 formed in the lower case section 12. A retaining screw 98 secures the guide to the stubshaft 96. It will be understood that the term "core" as used herein means an upstanding element having sufficient mechanical strength to withstand loads encountered by a tape guide. Thus, the metal insert may be made from material which is so thin that it lends negligible strength to the guide. Also, the term "semi-cylindrical" means any shape less than a full cylinder; it is not limited to a 180° arc.

The core 92 includes first and second semi-cylindrical segments 100 and 102. The first segment has a radius which is somewhat smaller than that of the second segment. For reference purposes only, the first segment describes an arc of about 217°, while the second seg-

ment describes an arc of about 170°. Where the segments overlap, the outer portion forms ears 104 separated from the inner segment by slots 106. The ears and slots run the entire length of the core. A central bore 108 extends through the core for receiving the retaining screw 98. Similarly, a counterbore 110 at one end of the core receives the stubshaft 96.

The metal insert 94 preferably is made of polished stainless steel. Advantageously, it can be made from a flat sheet of pre-finished stainless steel which is rolled to the radius of the first core segment 100. The steel thickness is on the order of 0.004-0.008 inches, which is significantly thinner than the material used for a standard steel tape guide. This results in material cost savings. The width of the slots 106 is somewhat less than the thickness of the insert material so that when the insert 94 is mounted on the core 92 the ears 104 will engage the edges of the insert in a press fit that tightly retains the insert on the core. It is preferred, though not required, that the arc of the insert 94 be somewhat greater than 180° to assist in retaining the insert in position. Further material savings are realized from the fact that the insert extends only about the portion of the guide which is likely to be in contact with the magnetic tape. Another advantage of using the insert 94 is a reduction in expenses for secondary finishing operations since tool marks are less noticeable.

FIG. 19 shows an alternate form of the tape guide. Here the core 112 has a shape similar to the core 92, but it is split into an upper portion 114 and a lower portion 116. The upper portion is integrally formed in the upper housing section 10, while the lower portion 116 is similarly formed in the lower housing section 12. During assembly the stainless steel insert 94 is placed either on the upper or lower core portion, with the opposite portion sliding into position when the two housing halves are brought together. A retaining screw 118 is then placed through the guide 112.

It is also contemplated that an arrangement such as the improved tape guide 91 may be substituted for pin 56. This would provide the same advantages as the guide provides over prior guide configurations.

Whereas a preferred form of the invention has been shown and described, it will be realized that changes may be made thereto without departing from the scope of the following claims.

I claim:

1. In a magnetic tape cassette, a reel spring comprising an elongated strip of resilient material having first and second edges extending substantially throughout its length parallel to a longitudinal centerline and perpendicular to a transverse centerline, and the strip further including a flat, central base portion, a first pair of transverse crimps at the ends of the base portion defining transition sections of the strip extending at a first angle to the plane of the base portion, and means for mounting said reel spring to the cassette and for fixing the reel spring's orientation relative to the cassette, said means being formed in said base portion intermediate said first and second edges, and said means being spaced outwardly of the transverse centerline and inwardly of the first pair of transverse crimps.

2. The spring of claim 1 further comprising a second pair of transverse crimps at the outer ends of the transition sections defining end portions of the strip extending at a second angle to the plane of the base portion.

3. The spring of claim 1 wherein the means for mounting said reel spring are disposed upon the longitudinal centerline of said spring.

4. The reel spring of claim 1 wherein the tips of the end portions are rounded.

5. The reel spring of claim 1 wherein the resilient material is stainless steel.

6. The reel spring of claim 1 wherein said means for mounting include separate means disposed on opposite sides of the transverse centerline.

7. The reel spring of claim 6 wherein said separate means for mounting are equidistant from said transverse centerline.

8. The reel spring of claim 7 wherein said means for mounting includes a pair of apertures through said base portion.

9. The reel spring of claim 8 wherein said apertures are circular.

10. A magnetic tape cassette having a housing with a pair of tape reels therein, the tape reels being biased by a reel spring, the reel spring comprising an elongated strip of resilient material having first and second edges extending substantially throughout its length parallel to a longitudinal centerline and perpendicular to a transverse centerline, and the strip further including a flat, central base portion, a first pair of transverse crimps at the ends of the base portion defining transition sections of the strip extending at a first angle to the plane of the base portion, and means for mounting said reel spring to the cassette and for fixing the reel spring's orientation relative to the cassette, said means being formed in said base portion intermediate said first and second edges, and said means being spaced outwardly of the transverse centerline and inwardly of the first pair of transverse crimps.

11. The magnetic tape cassette of claim 10 wherein the reel spring further comprises a second pair of transverse crimps at the outer ends of the transition sections defining end portions of the strip extending at a second angle to the plane of the base portion.

12. The magnetic tape cassette of claim 10 wherein the means for mounting said reel spring are disposed upon the longitudinal centerline of said spring.

13. The magnetic tape cassette of claim 10 wherein the tips of the end portions are rounded.

14. The magnetic tape cassette of claim 10 wherein the resilient material is stainless steel.

15. The magnetic tape cassette of claim 10 wherein said means for mounting include separate means disposed on opposite sides of the transverse centerline.

16. The magnetic tape cassette of claim 15 wherein said separate means for mounting are equidistant from said transverse centerline.

17. The magnetic tape cassette of claim 16 wherein said means for mounting includes a pair of apertures through said base portion.

18. The magnetic tape cassette of claim 17 wherein said apertures are circular.

19. In a magnetic tape cassette of the type having a housing containing a pair of tape reels mounted for rotation therein the improvement comprising a reel spring comprising an elongated strip of resilient material having first and second parallel edges extending substantially throughout its length, the strip having a central base portion and adjoining end portions extending out of the plane of the base portion, the base portion being defined by spaced apart upper and lower surfaces, one of which is in contact with the cassette housing when the spring is mounted therein, and means for mounting said reel spring to the cassette, said means being formed intermediate the spaced apart upper and lower surfaces of the base portion.

20. The spring of claim 19 wherein said means for mounting is disposed upon the longitudinal centerline of the spring.

21. The spring of claim 20 wherein said means for mounting is spaced from the transverse centerline of the spring.

22. The spring of claim 19 wherein said means for mounting include separate means disposed on opposite sides of the transverse centerline.

23. The spring of claim 19 further characterized in that the means for mounting are arranged so as to fix the orientation of the spring when the spring is mounted in the cassette housing.

24. The spring of claim 23 wherein said means for mounting is disposed upon the longitudinal centerline of the spring.

25. The spring of claim 19 further comprising a first pair of transverse crimps at the ends of the base portion defining transition sections of the strip extending at a first angle to the plane of the base portion, and a second pair of transverse crimps at the outer ends of the transition sections defining an outer end portion extending at a second angle to the plane of the base portion.

* * * * *

50

55

60

65